



TOGETHER
for a sustainable future

OCCASION

This publication has been made available to the public on the occasion of the 50th anniversary of the United Nations Industrial Development Organisation.



TOGETHER
for a sustainable future

DISCLAIMER

This document has been produced without formal United Nations editing. The designations employed and the presentation of the material in this document do not imply the expression of any opinion whatsoever on the part of the Secretariat of the United Nations Industrial Development Organization (UNIDO) concerning the legal status of any country, territory, city or area or of its authorities, or concerning the delimitation of its frontiers or boundaries, or its economic system or degree of development. Designations such as “developed”, “industrialized” and “developing” are intended for statistical convenience and do not necessarily express a judgment about the stage reached by a particular country or area in the development process. Mention of firm names or commercial products does not constitute an endorsement by UNIDO.

FAIR USE POLICY

Any part of this publication may be quoted and referenced for educational and research purposes without additional permission from UNIDO. However, those who make use of quoting and referencing this publication are requested to follow the Fair Use Policy of giving due credit to UNIDO.

CONTACT

Please contact publications@unido.org for further information concerning UNIDO publications.

For more information about UNIDO, please visit us at www.unido.org

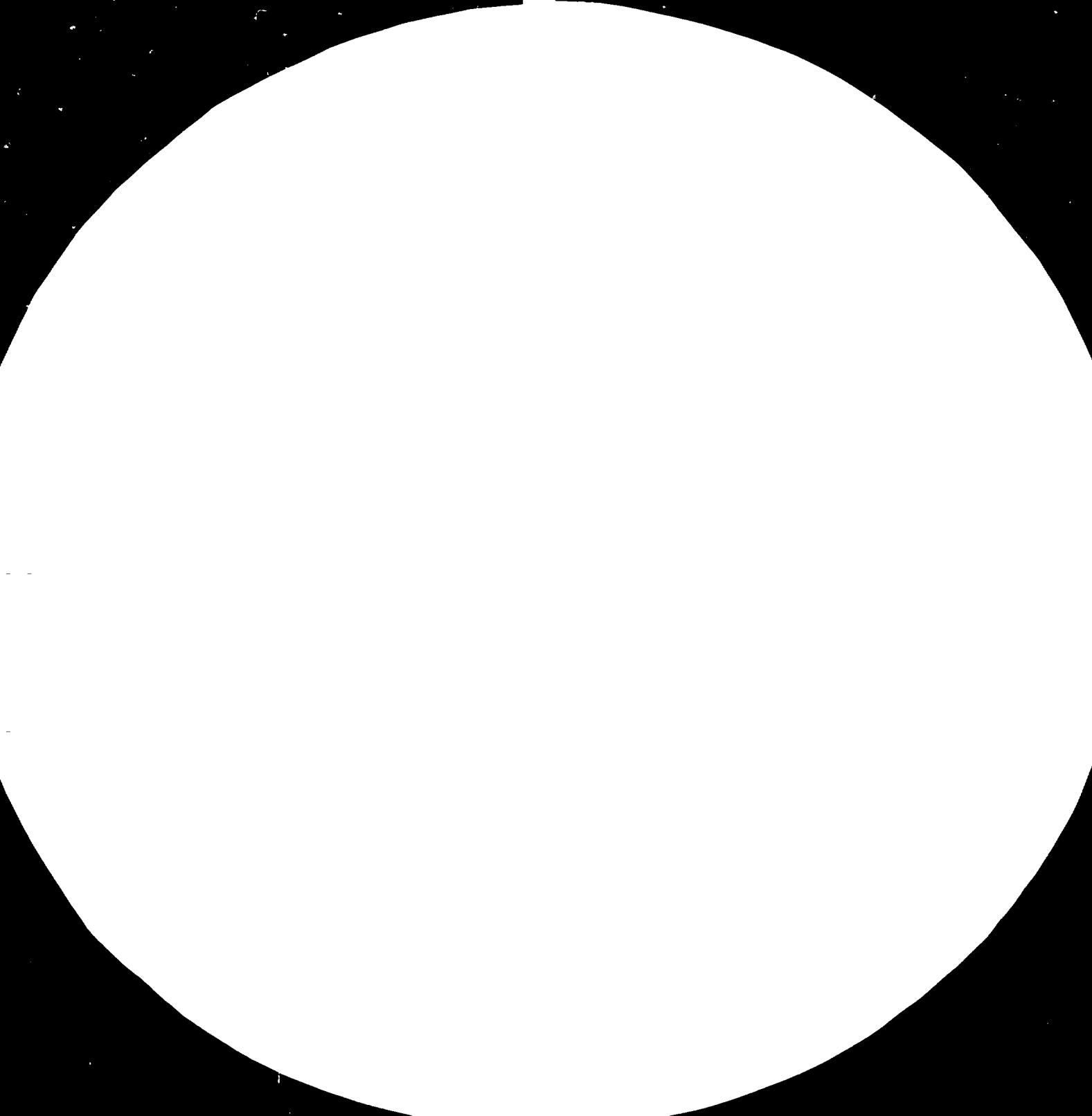



1.5 25

2.0 22



2.5 20

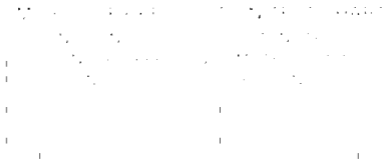
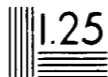

13530

RESTRICTED

12 April 1983
English

India.
TRAINING OF COUNTERPART PERSONNEL AT
CIPET-MADRAS IN BLOWN-FILM EXTRUSION
AND CONSULTANCY SERVICES

DP/IND/74/052/11 OLB/32.1H

INDIA

Technical report

Prepared for the Government of India
by the United Nations Industrial Development Organization

Based on the work of J.L.Th. Niesten,
expert in blown-film and extrusion

United Nations Industrial Development Organization
Vienna

This report has not been cleared with the United Nations Industrial Development Organization which does not, therefore, necessarily share the views presented.

ABSTRACT

CIPET/MADRAS has modern equipment to manufacture moulds, dies and injection moulding machines to prove and perfect these moulds and dies.

The extruders in the Processing Department are of such bad a quality and so much out of date that an adequate training of the counterpart personnel and students in the field of extrusion was not possible. Therefore the purpose of the mission: Training of counterpart personnel in the field of blown film techniques in all their aspects, could not be fulfilled.

With regard to the subject the expert went through the theory with the counterpart personnel, he formulated a number of test programmes and he advised the CIPET on the purchase of extruders and auxiliary equipment. For that purpose the expert called on a number of manufacturers of extrusion equipment and plastics processors to acquaint himself with the state of the art in India and the way in which industry is working.

GLOSSARY OF ABBREVIATIONS

LDPE	Low Density Polyethylene
HDPE	High Density Polyethylene
HMWPE	High Molecular Weight Polyethylene
LLDPE	Linear Low Density Polyethylene
PVC	Polyvinyl Chloride
PP	Polypropylene
PC	Polycarbonate

I. INTRODUCTION

A. Project background

CIPET/MADRAS Training Centre is quite a modern organization. It has the following departments:

- I Mould Design Department (design of moulds and dies)
- II Toolroom (manufacture of moulds and dies)
- III Testing Department (testing of polymers and products)
- IV Processing Department (proving of dies and moulds).

The main objective of the Processing Department is to prove moulds and dies, made in the Toolroom and if necessary to perfect them. It has a number of modern injection moulding machines for thermoplastics as well as compression moulding machines for thermosets (donated by UNIDO). The Processing Department also has an extruder for blow moulding and one for blown film production. They are of a very simple construction and not of a good quality. These two extruders and auxiliary equipment are out of date and it is impossible to produce good quality products with these machines. At the time these extruders were purchased the level of extrusion technology needed by Indian industry was unknown. At present roughly 200,000 tons a year of thermoplastics are produced in India, of which about 65% is processed by extrusion. It is therefore, necessary that the level of knowledge within CIPET/MADRAS in the field of extrusion technology is brought up to European and American standards.

B. Object of the mission

The purpose of the project was to provide assistance to CIPET/MADRAS in training counterpart personnel in processing blown film. Specific duties were:

- . systematic extruder start up, bubble lifting and film threading;
- . systematic product set up in relation to size and thickness of the film;

- . procedures for die lip cleaning, screen changing, purging, film treating, set up and extrusion shut down;
- . trouble shooting
- . improving of yield, quality, economical colouring;
- . selection and use of corona discharge treater systems.

To train counterpart personnel in the above mentioned subjects the available time should have been roughly divided in 75% practical and 25% theoretical training. It was, however, not possible to do any practical training on the extrusion equipment which was available.

II. RECOMMENDATIONS

A. To U.N.I.D.O .

To provide the Indian plastics industry with well-trained personnel at a number of levels in the field of plastics processing and extrusion, it is necessary that training in this domain is started as soon as possible. For that purpose CIPET/MADRAS and other future CIPET branches will have to be furnished with good processing equipment such as extrusion equipment for blow moulding, blown film, flat film, PE and PVC pipe-equipment and profile extrusion on single and twin-screw extruders.

1. CIPET should be advised on the purchase of the equipment, required for training of students and testing of moulds, dies and products.
2. UNIDO should send experts in the field of rheology, blow moulding, blown film, flat film, PE and PVC pipe extrusion to CIPET.
3. CIPET should also be provided with an expert in the field of design, testing and the extrusion of profiles on single and twin-screw extruders.
4. Present staff-members of CIPET's should, through UNIDO, be trained, either in India or abroad, in the mentioned techniques at:
 - . universities
 - . manufacturers of extrusion equipment
 - . plastics manufacturers
 - . research organizations.

B. To CIPET

Before purchasing any extrusion equipment for CIPET/MADRAS it is necessary to consider the equipment manufactured in India.

1. For this purpose CIPET should start a desk-research to select an extruder which, by Western standards, is up to date (Annex 4).

2. In future CIPET should set up training courses in

- . plastics technology
- . plastics processing
- . extrusion technology
- . refresher courses for key-operators in their specific fields of extrusion. For these courses it is advised that the text books, which should contain the necessary theoretical background information, are written in the vernacular tongue.

ACTIVITIES UNDERTAKEN

The first week of the expert's visit to CIPET/MADRAS was spent on lectures and workshop visits to interested CIPET staff members. An outline of these lectures is given in Annex 1.

In consultation with CIPET management the second and third week of the expert's visit was spent on:

- . studying the reports regarding the Plastics Product Testing Centre for Industry Development. They were read carefully and comments were discussed with Dr. Ramamurthy, Senior Engineer of the Testing Department;
- . a preliminary set up of a training programme for blown film production and extrusion (Annex 2 and 3);
- . advising CIPET on the purchase of extrusion equipment. To this end, during the third week of the expert's stay, R.H. Windsor Ltd., manufacturers of blow film equipment and Abura Industrial Engineers, manufacturers of blown moulding equipment, were called upon. The subjects discussed there can be found in Annexes 5 and 6.

The expert's visit to India was concluded by a visit to a number of industries in Ahmdabad, followed by a lecture to the members of the Gujarat Industrial and Technical Consultancy Organization LTD (Annex 7).

CONCLUSIONS

The Indian plastics processing industry has expanded enormously during the last few years and it is only due to the shortages and prices of raw materials that the expansion has not been much greater. Because of this fast expansion there is a shortage of skilled, highly trained personnel in every field of the plastics processing industry. The main cause at this moment is the impossibility of training students in the entire field of processing and extrusion.

In view of the improved position of plastics materials as well as in view of the demand for better extrusion technology and for the purpose of getting better quality and a higher production, it is suggested that the setting up of a Plastics Processing Centre may be best approached as a separate project.

CIPET/MADRAS, having the necessary experience and a skillful, experienced staff, seems to be a suitable institution in India to realise such a centre.

ANNEXES

ANNEX 1

LECTURES PRESENTED

1. The extruder as a pump
2. Polypropylene film extrusion (blown and flat film)
3. Extruder die-heads and dies
4. Blown film extrusion
Review and perspectives (Ahmdabad).

ANNEX 2

A PROGRAMME FOR BLOWN FILM EXTRUSION

1. Check the check list.
2. Start up according to advices in text book.

Each film being processed should be wrinkle free.

After each change in parameters samples should be collected and processing parameters should be noted on the flow sheet.

	Tem- perature profile (°C)	Screw speed (RMP)	Take-off speed (TOS) m/min	Lay-flat width ±0.025 cm (cm)	Film thick- ness ± 10 percent	Blow- up Ratio (BUR)	Frost line height (cm)
1	I	20	X	50	100	2:1	as low as possible
2	I	20	X	50	100	2:1	as high as possible
3	I	20	X	50	100	2:1	in between
4	I	20	1½ x X	50	60	2:1	best choice
5	I	20	slowly in- crease of TOS	50	increase TOR as thin as possible	2:1	best choice
6	I	20	Y	80	100	3:1	as low as possible

Vary BUR from 1:1 to 3:1 → Orientation in machine direction.

Increase die temperature - compare the maximum draw down ratio with 5.

Add some masterbatch colourant, check the time when the coloured melt leaves the die, where and how. (Average residence time).

Check the time all colourant has disappeared (this give an indication of how much time is needed in case of colour changing).

ANNEX 3

EXTRUSION (TRAINING PROGRAMME)

A die of simple construction (Fig. 1) attached to an extruder may give students a good impression of:

- The working capacity of an extruder
- The effect of screens mounted between screw tip and die
- The effect of screw cooling
- The temperature profile of the melt leaving the screw (melt homogeneity)
- The decrease in output caused by an increase in die resistance
- The influence of several temperature profiles and screw speeds on output and melt homogeneity
- Influence of screw configurations.

Equipment : 1. Extruder, diameter 45 mm L/D 25D
2. Screws.

CIPET made : 1 Breaker Plate and Screws
1 Bush to replace the breaker plate
1 Die head
3 Cylindrical dies with various bores
1 Pelletiser
2 Pressure transducers

CIPET made : 3 Melt thermocouples
1 Multiple channel temperature recorders (12 or 16)
1 2 Line mV Recorder (Pressure recording)
1 Stop watch
1 Scanner
1 Balance.

Screw I - Resin A - Without Breaker Plate and Screens
Temperature Set I

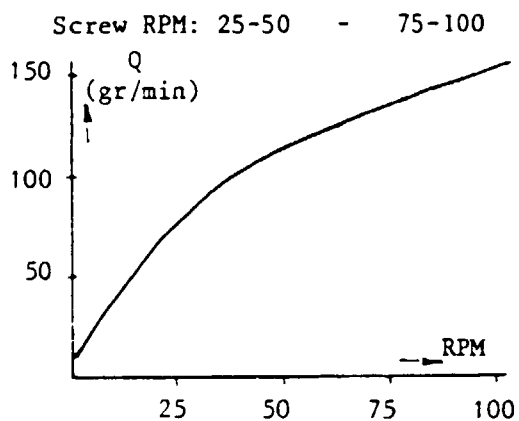

After measuring the output at two screw speeds, predict the output at the third speed. Do the same for the fourth speed.

Collect all the data on a flow sheet

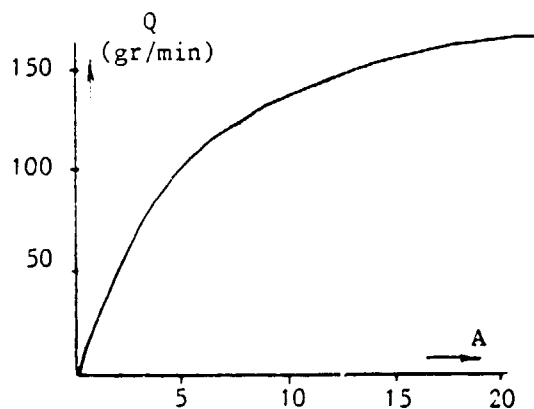

Ammeter Reading indicates the power consumption

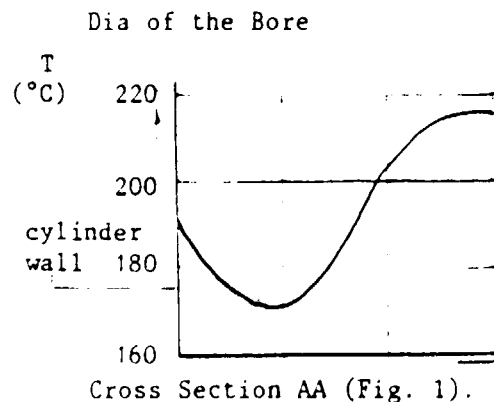

Temperature profile measured in the cross-section of the die head for one screw speed.

Test the quality of the melt by stretching it when it leaves the die. A smooth surface and long stretching indicates good melt quality. If the pressure and temperature profiles fluctuates too much, increase the temperatures of barrel zones and die.

EXTRUSION PROGRAMME

SCREW NUMBER	BREAKER PLATE & SCREENS	DIE NUMBER	RESIN	TEMPERATURE PROFILE
I	NONE	I	A	I
I	YES	I	A	I
I	YES	I	A	II
I	YES	II	A	I or II

- 1 The best suitable circumstances for die III
- 2 Screw number II is not exactly suited for Resin A
Find an optimum for three dies in output and melt homogeneity.

EXTRUDER DIEHEAD

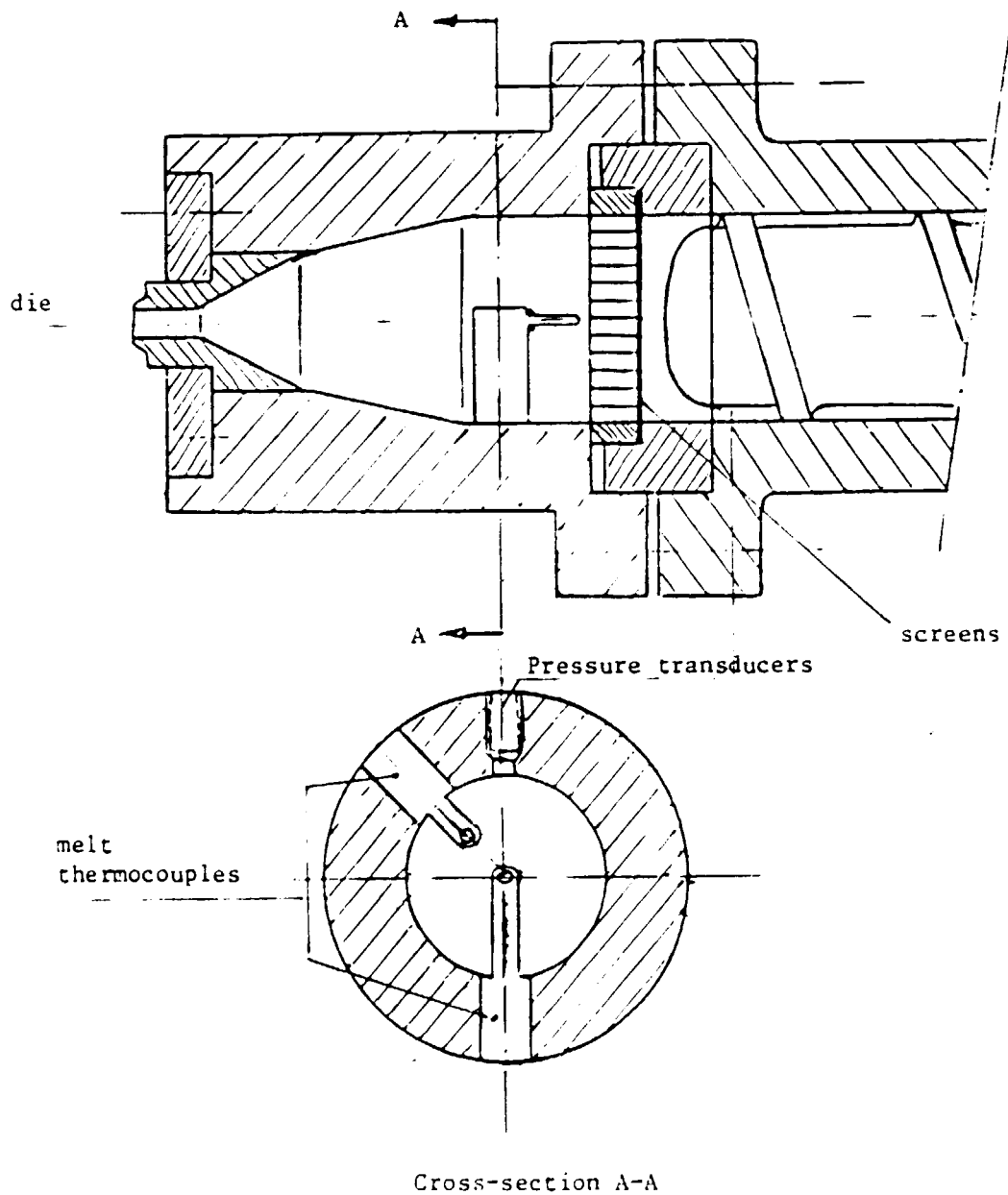

FIGURE 1

ANNEX 4

PROFILE OF A MODERN EXTRUDER

In order to make a satisfactory analysis of the working efficiency of an extruder CIPET-MADRAS needs at least one extruder which is up to date.

The extruder can be used in the total extrusion field, namely: in extrusion rheology, blown film, pipe and small profile extrusion. The extruder should be equipped with PID temperature controllers, ammeter and RPM meter and as optional a screw torque measurement. The barrel zones temperatures should be controlled by water cooling or airblowers.

extruder screw diameter	45 mm
length	variable 20-30 D, in order to be able to use a vent screw as well.
drive motor	Ac/dc drive 0.25-0.35 HP/kg/h output
feed zone	smooth
feed zone	with rectangular grooves, water cooled, length 3 - 5 D.
screws for the smooth barrel	1 screw with changeable shearing and mixing device and metering zone
	1 barrier screw
	1 vent screw
	1 rigid PVC screw
screws for the grooved barrel	1 screw for HDPE and PP
	1 screw for LLDPE
	1 screw for PVC powder

In combination with a specially constructed diehead, this extruder (see figure 1, annex 3) can be used for teaching extrusion technology up to a high level.

ANNEX 5

REQUIREMENTS FOR A BLOWN FILM EQUIPMENT TO BE
PURCHASED BY CIPET

- CIPET needs a blown film equipment, with several dies and dieheads to process LDPE, HDPE, PP and rigid PVC thermoplastics.
- A removeable tower, in case the extruder is used for other extrusion experiments is recommended.
- For blown film extrusion of PP a downwards water bath with collapsing frame and take-off rolls is recommended.
- There is no need for high production, but optimal aircooling of the bubble, good adjustment of the die and collapsing frame, and easy access to the nip-rolls are important.

Visit to WINDSOR (India) Ltd. (blown film line) on June 21st, 1982.

Present for CIPET:

- . Mr. D.N. Pandey, Senior Plastics Engineer (Processing)
- . Mr. J.L.Th. Niesten, UNIDO Expert

Present for WINDSOR:

- . Mr. F. Pinto, Marketing Manager
- . Mr. T.K. Patel, Technical Manager.

- A 45 mm extruder can be supplied at standard centre height. As for downwards watercooled blown film processing of PP, Windsor Ltd. can construct a platform to increase the centre height.
- Barrel is nitrated. According to WINDSOR, no problems will arise in case of processing rigid PVC.

- Nitrided screws for processing the polyolefins and rigid PVC can be supplied (no removeable tip). In case of vent extrusion barrel and screw lengths are 30 D. An extra barrelpiece can be supplied for this purpose.
- The locations for pressure transducers and melt thermocouples were discussed. Windsor can make the holes in barrel - and dieheads. All holes are plugged. They have no experience with pressure transducers.
- Through HAAKE they can supply Dynisco pressure transducers and melt thermocouples as well.

COMMENTS:

- . From the technological point of view this blown film is good according to Indian standards, but moderate compared to Western European standards (a profile of such an extruder is given in Annex 4).
- . There is no experience with grooved feed zones and the modern screw design, needed for the higher output rates, obtained with grooved feed zones.
- . As for screws for conventional extruders (smooth barrels), no experience is available with the construction of barrier flight screws and screws with mixing and shearing devices. Only one type of mixing device can be supplied.
- . In the near future, when HMWPE and LLDPE is to be extruded with high output rates, there will be a demand for extruders which can deliver melt to the die with: low screw speed, high output rate and low shear, necessary for processing the above mentioned thermoplastics to obtain films of high optical and mechanical quality.
- . It is a government/CIPET decision to make the choice between an extruder of Indian brand or an extruder according to Western European standards.

ANNEX 6

REQUIREMENTS FOR A BLOW MOULDING EQUIPMENT
TO BE PURCHASED BY CIPET

- CIPET needs a versatile single station blow moulding machine for producing bottles of a capacity of 1 liter and small containers of up to 2 liters.
The thermoplastics being processed are HDPE, LDPE, PP, rigid PVC and PC.
- There is no need for high speed production.
Easy access to the extruder and blow station and a good view on all functions will be of importance.

Visit to AHURA INDUSTRIAL ENGINEERS (blow moulding machines) on June 22nd, 1982.

Present for CIPET:

- . Mr. D.N. Pandey, Senior Plastics Engineering (Processing)
- . Mr. J.L.Th. Niesten, UNIDO Expert

Present for AHURA:

- . Mr. P.E. Jussawalla, Director.
- The extruder screw has a diameter of 38 mm. The construction is simple, but the screw is easy to clean.
- Extruder heater zones, crossheads, etc. will be equipped for CIPET with the possibilities of measuring the temperatures, melt temperatures and pressures as well.
- One crosshead equipped with parison programming (three steps) for processing polyolefins and PC can be supplied.

- Clamping force is sufficient for producing bottles and containers up to 2 litres. Depending on shape 2.5 and 3 litres production of containers is possible.
- Plates and mould dimensions are very good for a blow moulding machine of this size.

COMMENTS:

Ahura is a small, independent Indian manufacturer of blow moulding equipment. However, it developed its own machinery. They are simply built, but of sturdy construction and they perform very well. There is easy access to all parts and quick changes of dies and moulds are possible.

ANNEX 7

The following industries were visited by the expert:

- . Southern Polymer Industries,
Tambara, Madras
LDPE and PP blown film processor

- . ASIT Plastic Industries
AHMDABAD
Processor of LDPE and rigid PVC blown film

- . Pathal Polymer Alloys,
AHMDABAD
Multi-layer blown films,
Compounder of masterbatches

- . Windsor (India) Ltd.,
BOMBAY
Manufacturer of injection moulding and blown film equipment

- . Ahura Industrial Engineers,
AHMDABAD
Manufacturer of blow moulding equipment

- . SLM MANKLAL Industries Ltd.
Manufacturer of injection moulding and blow moulding equipment.

