



TOGETHER
for a sustainable future

OCCASION

This publication has been made available to the public on the occasion of the 50th anniversary of the United Nations Industrial Development Organisation.



TOGETHER
for a sustainable future

DISCLAIMER

This document has been produced without formal United Nations editing. The designations employed and the presentation of the material in this document do not imply the expression of any opinion whatsoever on the part of the Secretariat of the United Nations Industrial Development Organization (UNIDO) concerning the legal status of any country, territory, city or area or of its authorities, or concerning the delimitation of its frontiers or boundaries, or its economic system or degree of development. Designations such as “developed”, “industrialized” and “developing” are intended for statistical convenience and do not necessarily express a judgment about the stage reached by a particular country or area in the development process. Mention of firm names or commercial products does not constitute an endorsement by UNIDO.

FAIR USE POLICY

Any part of this publication may be quoted and referenced for educational and research purposes without additional permission from UNIDO. However, those who make use of quoting and referencing this publication are requested to follow the Fair Use Policy of giving due credit to UNIDO.

CONTACT

Please contact publications@unido.org for further information concerning UNIDO publications.

For more information about UNIDO, please visit us at www.unido.org

RESTRICTED

18422

DP/ID/SER.A/1357
7 June 1990
ORIGINAL: ENGLISH

STRENGTHENING OF THE ESSENTIAL OIL
INDUSTRY IN KOREA

DP/DRK/88/001/A/01/37

DEMOCRATIC PEOPLE'S REPUBLIC OF KOREA

Technical report: Design of modern chemical equipment for
the production and processing of essential oils*

Prepared for the Government of
Democratic People's Republic of Korea
by the United Nations Industrial Development Organization,
acting as executing agency for the United Nations Development Programme

Based on the work of Mr. Siegfried Langner,
UNIDO consultant

Backstopping Officer: R.O.B. Wijesekera
Chemical Industries Branch

United Nations Industrial Development Organization
Vienna

* This document has not been edited.

ABSTRACT

Title of the project: Strengthening of the Essential Oil Industry in Korea

Number of the project: DP/DRK/88/001/A/01/37

Job description number: DP/DRK/88/001/11-02

Qualification: Chemical Design Engineer

It was the original purpose of the activity reported on hereinafter to give technical advice in support of the design and manufacture of improved equipment for the essential oil industry in the D.P.R. of Korea. At the request of the Korean partners, however, the consultations on the construction of equipment were cancelled and advice on chemical engineering and technology in the respective branch was included in the programme instead.

This report informs about the actual situation and the stage of development achieved in Korea with respect to fundamental equipment and the involved technologies for the production and processing of essential oils, making reference, at the same time, to some principal aspects of the international state of the art. Over and above that, it includes suggestions and recommendations that aim at improving and advancing the equipment and technologies presently applied to the Korean essential oil industry.

TABLE OF CONTENTS

	Page
Abstract	2
Table of contents	3
Introduction	6
Recommendations	7
I. General remarks	11
II. Equipment and technology for the production of essential oils by extraction	14
A. Stage of development reached in the D.P.R. of Korea	14
1. First bench-scale equipment for the extraction and the recovery of the solvent	14
2. Laboratory equipment for the recovery of solvents and the production of "concrete" essential oil	20
3. Equipment for the production of "absolute" essential from "concrete" oil	24
4. P.E.O.R.C. draft design for the construction of bench-scale equipment with vacuum film evaporator	26

	Page
B. Discussion of problems and suggested improvements on equipment comprising vacuum film evaporators	29
C. Elaboration of the technical specification for a vacuum film evaporator	33
III. Equipment and technology for the production of essential oils by steam or water distillation	34
A. Stage of development achieved in the D.P.R. of Korea	34
B. Information about modern advanced equipment	35
C. Water distillation equipment and technology for the extraction of oil from the Rosa rugosa	44
IV. Batch vacuum rectification equipment for essential oils processing	45
A. Stage of development achieved in the D.P.R. of Korea	45
B. The international state of art, presented by the example of some leading firms	47

	Page
C. Elaboration of the technical specification for modern bench-scale batch vacuum rectification equipment	50
V. Other questions	50
VI. Conclusions	42
 Annexes	
1 The senior counterpart staff, their names and specializations	54
2 Briefing notes for to Langner, Chemical Design Engineer	55
3 Time schedule of the activities	56
4 Addresses of foreign companies suggested for participation in a tender for bench-scale equipment	57
5 Specification for bench-scale equipment with vacuum film evaporator	58
6 Specification for bench-scale equipment for batch vacuum rectification	67

INTRODUCTION

The purpose of this report is to accomplish an activity under the joint development project number DP/DRK/88/01/A/01/37, entitled "Strengthening of the Essential Oil Industry in the D.P.R. of Korea" that was signed between the Korean government and UNDP/UNIDO in May, 1988.

Said project activity reads as follows:
"II.G Project inputs, 1. International staff, 11-01 Chemical design engineer with up-to-date experience in the field of essential oils, who will assist national personnel in the design and local construction of improved distillation equipment".

The task to be tackled by the chemical engineer is specified in the Job Description DP/DRK/001/11-02 (See Annex B to the above-mentioned development project.) and in the UNIDO Briefing Notes that were handed to the consultant in Vienna, on November 7, 1988. (Annex 2)

The original purpose of the activity and the consultant's duties were partly revised and supplemented since the consultant was informed in Pyongyang of the existence of sufficiently developed local facilities for the construction of chemical equipment for the essential oil industry in Korea. Hence, his advice on this subject was not required. On the other hand, the Korean partners asked the consultant for additional consultation on questions of chemical engineering and technology related to the extraction and distillation of essential oils. And he was requested to assist the Korean specialists in the elaboration of tender specifications for bench-scale equipment, to serve as a basis for submissions by foreign companies.

The consultant was able to meet this request, because he is also qualified and experienced in chemical process technology.

It is the specific purpose of this document

- to inform about the present situation and the level achieved in the D.P.R. of Korea in the field of fundamental equipment and the involved techniques for the production and processing of essential oils,
- to outline some of the principal aspects of the international state of art in this particular field and
- to make suggestions for the improvement of the equipment that is presently used in this country.

The reported activity was taken up on November 6, 1988, and it was concluded on December 2 of the same year. For the time schedule, see Annex 3.

The Korean partners and the consultant are unanimous in assessing that the activity in its modified and supplemented form has fully accomplished its aims.

RECOMMENDATIONS

1. In accordance with the first conclusion drawn in Chapter VI, we recommend the D.P.R. of Korea and UNDP/UNIDO to implement the project for the "Strengthening of the Essential Oil Industry in Korea", taking into consideration the following aspects.

2. Equipment for the solid-liquid extraction of essential oils from flowers with organic solvents

Here the Korean side should :-

- 2.1. in future use reliable batch-processing equipment for solid-liquid-extraction on a commercial scale (with total volumes per unit ranging from 1 to 3 cubic meters) that is fitted with modern flower charging and discharging systems such as baskets and is provided with solvent circulation pumps in order to intensify the extraction process,
- 2.2. carry on the investigations into the removal of the solvent and its traces from the extract by means of low-temperature vacuum film evaporators, rotary vacuum film evaporators and freeze-drying on bench scale,
- 2.3. improve the stage of solvent extraction from "concrete" oil with film evaporators running at temperatures above the oil's melting point (> 40 oC), leading the molten oil directly from the evaporator into a cold liquid like ethanol, and test said process by using a rotary vacuum film evaporator.
- 2.4. check the effectiveness of the vacuum system described in subsection II.A.4,
- 2.5. consider the application of modern techniques and equipment for the extraction by supercritical gases, particularly by carbon dioxide, and carry out the necessary tests at a trial station abroad, above all for the extraction of lilac oil,

- 2.6. analyse the solvent n-hexane by gas-chromatography and compare its quality with that of imported n-hexane,
3. Equipment for the production of essential oil from plants by steam or water distillation

Here the Korean side should

- 3.1. develop and construct modern industrial steam or water stills featuring
 - . distilling kettles with volumes between 3 and 5 cubic meters,
 - . modern charging and discharging system for vegetable raw materials (baskets, tiltable bottoms etc.),
 - . modern steam heating systems and
 - . improved oil separatorsfor future application to such regions of the country as satisfy the necessary preconditions.
- 3.2. use mobile steam distillation equipment in the form of containerunits for the future production of essential oils from herbs grown in the fields (e.g. peppermint).
- 3.3. modify the water distillation equipment and process in order to exploit the advantages of this method for the production of essential oil from *Rosa rugosa* in accordance with section III.C.
4. Equipment for the processing of essential oils by batch vacuum rectification

Here the Korean side should

- 4.1. gradually substitute the simple stills without columns, which are currently used for the purification of essential oils on a commercial scale, for up-to-date batch vacuum rectification equipment that would guarantee higher outputs and an improved quality of the essential oils.
- 4.2. supplement the curricula of the courses for the training of the Korean personnel abroad by instructions in the operation of modern equipment for the batch vacuum rectification of essential oils.
- 4.3. have some Korean experts (chemical process engineers) trained in the design, optimized operation and advancement of such equipment in accordance with the international state of art.
- 4.4. further improve the quality of the final products by employing modern packings in the columns, as soon as sufficient experience in the handling of modern batch vacuum rectification equipment was gained.
5. UNIDO is recommended to send the enclosed specifications (Annexes 5 and 6) for bench-scale vacuum film evaporator and batch vacuum rectification equipment (see Development Project, Annex III, List of Equipment, No. 10 and 11) to three foreign companies as basis for submissions. We suggest the following foreign firms:
 - Tournaire / France
 - Sulzer / Switzerland
 - VEB Komplette Chemieanlagen Dresden / G.D.R.

The addresses are given in Annex 4.

Submissions should be forwarded to the Korean partners in order to enable them to prepare their decision upon conferring the contract. One should bear in mind, however, that the budget (US \$) for the present development project is limited with respect to the equipment cost, too, so that any decision on the scope of deliveries should reasonably be governed by the priorities of individual equipment outlined in sections II.C and IV.C.

6. The Korean partners and UNIDO are recommended to include a visit to the G.D.R. in the next study tour of developed industrialized countries made by Korean experts.

7. The Korean partners are recommended to pay special attention to the necessary measures of fire protection and safety against explosion when equipment is operated with solvent n-hexane in closed rooms.

All international safety regulations are to be observed.

I. GENERAL REMARKS

The representatives of the Pyongyang Essential Oil Research Centre (P.E.O.R.C.) and the consultant usually met at the Taedonggang Hotel in Pyongyang where they discussed questions of design and technology in the field of essential oil production.

For senior counterpart staff, their names and specializations, please, refer to Annex 1.

In the beginning, the director of the P.E.O.R.C. reported on the history, structure and purpose of his

research centre that was founded on April 13, 1984. Its predecessor had been a small-scale laboratory concerned with the winning of essential oils from roses, lilacs and lilies of the valley.

The future structure of the P.E.O.R.C. is outlined in the Development Project No. DP/DRK/88/001. The research centre has to play an important part in the development of the Korean essential oil industry. Its principal duties today are

- to establish and extend the institute under the aforementioned development project,
- to contribute essentially to the improvement, intensification and modernization of technology and equipment for the production and processing of essential oils in the D.P.R. of Korea and
- to create the bases for improving the quality and diversifying the range of essential oils of Korean make.

Same as before, the P.E.O.R.C. concentrates its research efforts on the production of high-quality essential oils from the flowers of roses (*Rosa rugosa*), lilacs (*Syringa dilatata*) and lilies of the valley (*Convallaria majalis* L.) by solid-liquid-extraction with organic solvents. Predominantly used solvents are:

- normal hexane (n-hexane) for flower extraction and
- ethanol for the production of "absolute" oil from "concrete" oil.

The Korean experts informed in detail about their country's resources of the above-mentioned flowers.

The wild growth of *Rosa rugosa* is particularly concentrated in the northeast of Korea, on a coastal strip about 400 km long and 2 km wide. A favourable habitat of this plant is the valley of the Tumangang river, where it is spread over an area of 2000 Dschongbo (1 Dschongbo = 0.99174 ha). The amount of flowers harvested from one Dschongbo in the course of the year is 4000 kg and higher, as this species is blooming from Mai until October.

At present, a total of about 300 t of *Rosa rugosa* flowers are harvested in the D.P.R. of Korea every year. This quantity can be considerably increased in the future. *Rosa rugosa* also grows in Japan, where a Japanese company has been producing oil from this rose since more than 100 years. Owing to the fact that the resources of this flower are limited in Japan, said company has pronounced its intentions to buy *Rosa rugosa* essential oil from Korea in the future.

Analogously to the *Rosa rugosa*, there are also large resources of lilac and lily of the valley growing wild in the mountains. In the north of the country the bushes of white lilac sometimes cover the mountains over a width of 6 kilometers and a length of some dozen kilometers. In Pyongyang and its surroundings the lilac is blooming from 25 April until the 20 May, and in the north country from 15 July until 15 August. It is particularly concentrated in the Sang-Wyen region north of Pyongyang.

The lily of the valley grows in closed mountainous habitats, in a total area estimated at some 7000 Dschongbo. Its blooming season coincides with that of the lilac, also commencing in the south and progressing northward.

The topics of the meetings held between the representatives of the P.E.O.R.C. and the consultant as well as their results are described in the following chapters.

II. EQUIPMENT AND TECHNOLOGY FOR THE PRODUCTION OF ESSENTIAL OILS BY EXTRACTION

A. Stage of development reached in the D.P.R. of Korea

1. The first bench-scale equipment for the extraction and the recovery of the solvent (fig. II/1)

- Information about this equipment was obtained through
 - . an oral report,
 - . coloured photographs and a principle flow sheet and
 - . the visual inspection of the equipment in a storage room.
- Mode of operation of the equipment:
periodic
- Brief description of the plant and the equipment:
All equipment at ground level, under a shelter. Flexible tubes for feed and discharge and for connection between individual apparatuses. Equipment made of grade SUS 304 stainless steel (DIN 1.4301).

a) Extractor

- . upright cylindrical vessel with lid,
- . tiltable to facilitate emptying,
- . volume: approx. 200 l,
- . height: approx. 1000 mm,
- . diameter: approx. 600 mm,

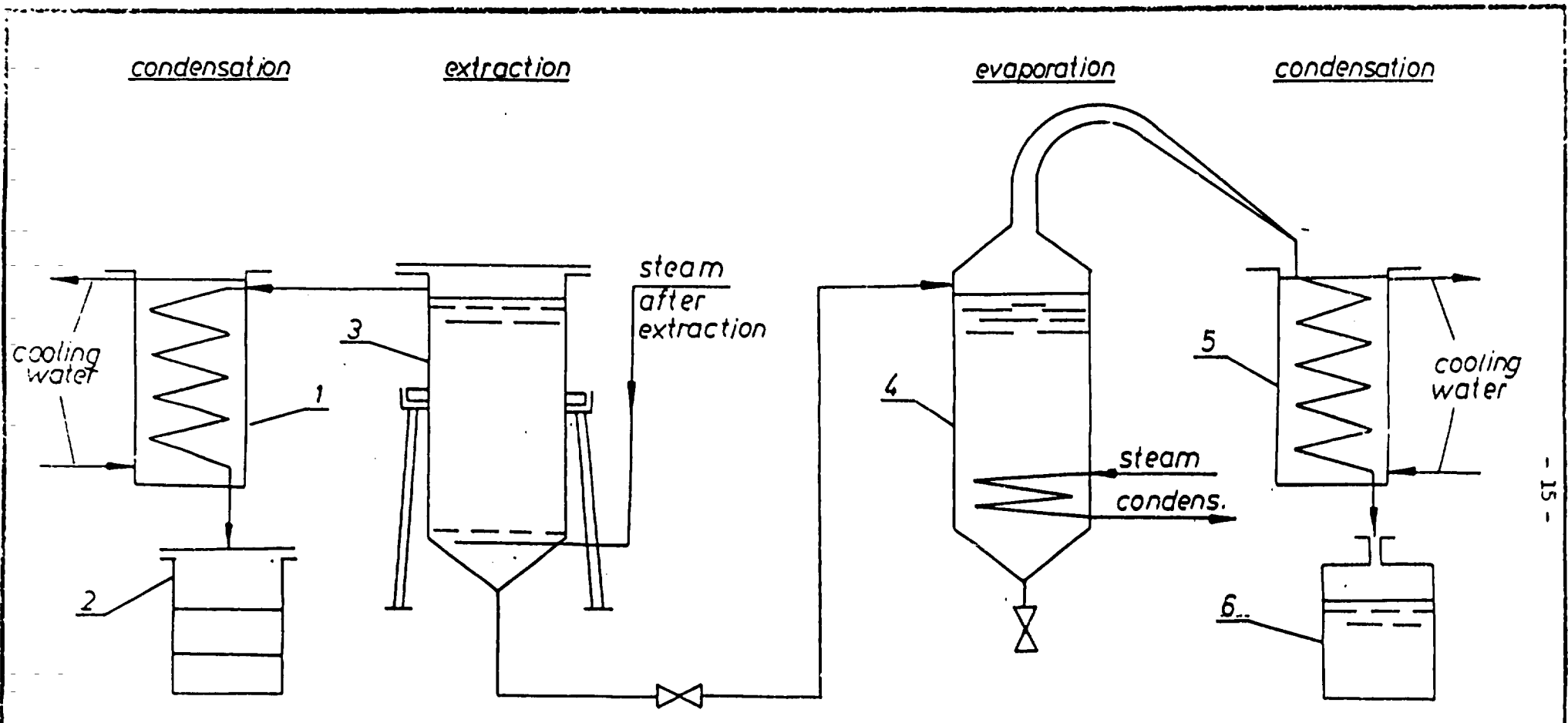

- 1 - condenser
- 2 - receiver-separator
- 3 - extractor
- 4 - evaporator

- 5 - condenser
- 6 - receiver

UNIDO/88/Langner/fig. II/1
 Principle flowsheet, extraction

- . perforated tray above the bottom,
- . tube ring under said tray, provided with small bores for the injection of steam after the extraction and the discharge of the solvent, in order to remove from the flowers any solvent residues,
- . connection from the extractor to a water-cooled spiral condenser, designed for condensing the steam/n-hexane mixture,
- . catch-pot for water and liquid n-hexane arranged under said condenser,
- . connection from the extractor to the evaporator via valve,

b) Evaporator

- . upright, cylindrical vessel with tapering bottom and lid,
- . heating coil installed in the lower section,
- . volume: approx. 160 l.

- Technology:

a) Extraction

- . solvents: n-hexane, benzol, petroleum ether,
- . pressure and temperature: normal

- . charge: 50 kg of flowers and 150 l of solvent,
- . extraction period: 1 to 2 h.
- . after extraction, the liquid is transferred to the evaporator, while the flowers are treated with steam for recovery of the solvent.

b) Evaporation of the solvent

- . pressure: atmospheric,
- . temperature:
 - in the beginning of evaporation: approx. 60 °C,
 - at the end of evaporation: approx. 80 °C,
- . heating fluid: saturated steam at 100 °C,
- . evaporation period: approx. 2 h,
- . product residues at the bottom after evaporation: approx. 30 l,
- . The solvent vapours flow to the spiral condenser where they are condensed with the aid of cooling water. After condensation, the solvent enters a receiver tank.

- Results

a) Extraction

Extragent	Extraction period (h)	kg of "concrete" oil obtained from 1000 kg of Rosa rugosa flowers
benzol	11)	3.0
n-hexane	2	2.0 - 2.32)
petroleum ether	2	1.5 - 1.7

1) At the end of this extraction period the flowers had turned white.

2) The quantity of "concrete" oil could be increased to 2.5 kg when the solvent was made circulate with the aid of a pump (two circulations per hour).

. Yield of "concrete" essential oil extracted from Rosa rugosa with n-hexane: 65 to 70 %.

. The "concrete" oil of Rosa rugosa contains 40 to 50 % of "absolute" essential oil.

b) Evaporation of the solvent

. At the final stage of evaporation, part of the essential oil evaporates together with the solvent.

- . Quality of the product (extract) after the evaporation of the solvent: insufficient; colour: dark brown; no scent of flower.

The above-mentioned evaporation equipment had been in use until 1986.

2. Laboratory equipment for the recovery of solvents and the production of "concrete" essential oil

The information was obtained through

- an oral report,
- a principle flow sheet and
- visual inspection of the equipment in a laboratory.

The insufficient quality of the extract produced on bench-scale equipment (see subsection II.A.1.) can be traced back to the decomposition of the essential oil in consequence of the excessively high temperatures and long residence times at the solvent evaporation stage. That is why the type of equipment and the technology at this stage were changed. A vacuum film evaporator was used, offering the following advantages:

- large product surface for solvent evaporation,
- short product residence time and
- low product temperature.

At the P.E.O.R.C., a laboratory glass plant with vacuum film evaporator was set-up as outlined in the following.

- Design and technology were similar to those of the bench-scale equipment described in Annex 5 and shown in fig. annex 5/1.

- Characteristic features of the laboratory equipment and technology are

- . volume of vessel V 2
(fig. annex 5/1): approx. 4 l
- . volume of vessel V 3
(fig. annex 5/1): approx. 4 l
- . jacketed evaporation tube: diameter 10 mm
length 1000 mm
- . absolute pressure at
the evaporator top: 13.3 kPa
(= 100 mm Hg)
- . Warm water temperature (inlet): 25 °C
- . Throughput rate of the liquid
n-hexane/wax ("concrete" oil)
mixture toward the evaporator
top: approx. 4 kg/h

- With the equipment above the following principal results were obtained:

- . n-hexane evaporation rate during
the first passage of the mixture: 3.0 to 3.5 kg/h
- . When the mixture had passed the evaporator three
times, it featured an n-hexane concentration from 5
to 10 percent in weight and a melting point below
25 °C.

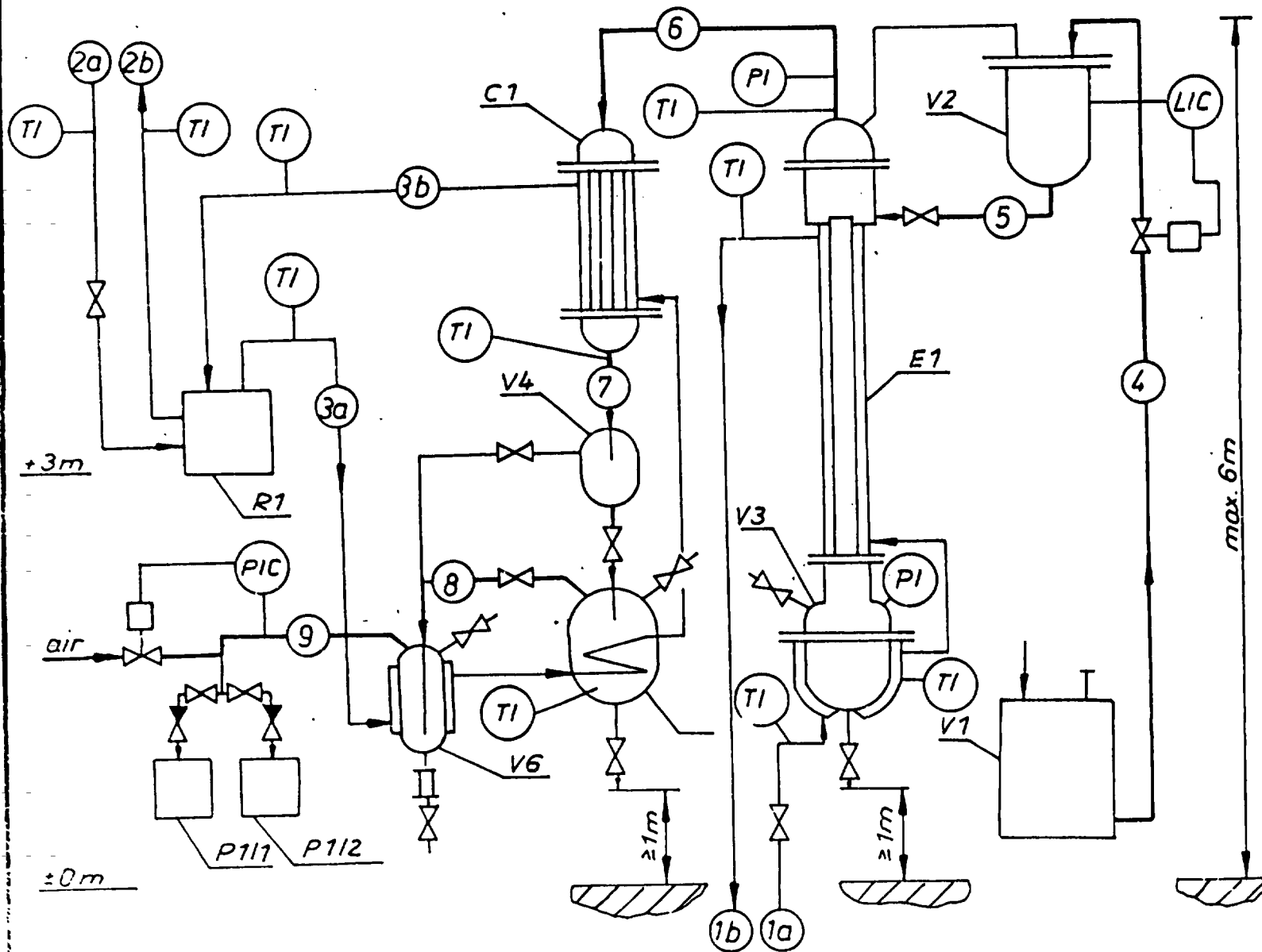

Designations:
 V1...6: vessels
 E1: evaporator
 C1: condenser
 R1: refrigerator
 P11; 1/2: vac. pumps
 TI: indic. of temp.
 PI: indic. of press.
 PC: aut. press. control
 LC: aut. level control
 1a, 1b: warme water
 2a, 2b: cooling water
 3a, 3b: refrigerant
 4 - 9: numbers of streams

UNIDO/86
 Langner
 fig. annex 5/1
 Principle flow sheet
 film evaporator

. no decoloration of the product

After vacuum film evaporation, the concentration of the n-hexane in the afore-mentioned mixture was further decreased by low-temperature batch vacuum distillation in laboratory apparatuses, reaching as low a concentration as about 2 percent in weight at a melting point around 30 °C. Such mixture still features a distinct smell of n-hexane.

The P.E.O.R.C. developed the idea of freeze-drying the "concrete" essential oil for freeing it completely from the n-hexane and its traces and it applies this method at temperatures ranging from -20 to -25 °C. In these conditions the "concrete" oil is solid. Before freezing, it is formed into balls, bars or the like in order to obtain a large surface.

Another method applied by the P.E.O.R.C. to the complete removal of n-hexane from "concrete" essential oil at laboratory scale consists in mixing the latter with ethanol that afterwards is evaporated together with the traces of the n-hexane.

Samples of this "concrete" oil were shown to the consultant. It had been produced from the Rosa rugosa and was of the following quality:

- fundamental evaluation: good
- colour: yellow (similar to honey)
- scent: flowery
- melting point: aprox. 40 °C
- acid number: 22.0
- ester number: 30.4

No samples were shown of the "concrete" oils made from lilies of the valley and lilac. "Concrete" lilac oil had been

produced, but the results were unsatisfactory: worse colour than the Rosa rugosa oil and no flowery scent.

3. Equipment for the production of "absolute" essential oil from "concrete" oil

In the beginning, the consultant reported of the equipment and technology applied in this field in the G.D.R., e.g. to the production of jasmin oil:

- General aspects: batch-type process at laboratory scale, mainly using glass apparatuses, manual work.

- Procedure:

- . 1 kg of "concrete" oil is dissolved in 6 l of ethanol (96 %), at normal pressure and normal temperature, stirring the liquid for about 3 hours.
- . The solution is cooled in a bottle that is placed into an ice/salt packing (at temperatures ranging from -15 to -20 oC).
- . Then the liquid is vacuum-filtered through filtering paper in a funnel.
- . The ethanol is evaporated at normal pressure in a steam-heated glass recipient (of approx. 10 l in volume), while a water-cooled glass condenser is used for condensation of the ethanol vapours.
No column.
- . The separated wax is subjected to this treatment two or three times more, in order to increase the "absolute" oil yield.

. The yield of "absolute" oil amounts to some 50 %.

The Korean experts confirmed that they apply the same technology to the production of "absolute" oil. For evaporation of the ethanol they use a lab-type vacuum film evaporator. The filtering paper (about 1.5 mm thick and of special texture) is imported from France. Japanese firms buy the same paper from France, too.

Given in the table below are the qualities of "absolute" essential oils.

Properties or parameters	Rosa rugosa	Lily of the valley (Convallaria majalis L.)
colour	golden-yellow	lightly yellow
scent	flowery	flowery
melting point	20 oC	-
d25	1.0081	0.9159
20	+ 20o30	-
20	1.5050	1.4689
acid number	12.8	108.5
ester number	39.5	39.5

Main components of the "absolute" oil of Rosa rugosa (weight percentages):

phenyl ethyl alcohol	30.5
geraniol	11.8
citronellol	10.9
methyl eugenol	12.0
eugenol	18.6

benzyl alcohol	1.9
nellol	6.3
benzyl acetate	1.3
and others.	

Last summer, some samples of "absolute" essential oils obtained from the Rosa rugosa and the lily of the valley were sent to Bulgaria, France and China for expertise of quality. The results are said to have been good. The gas-chromatograms received from Bulgaria did not show any solvent peaks.

The very pleasant smell of these oils was certified by the Robertet Company (B.P. 100/0633 Grasse Cedex France).

4. P.E.O.R.C. draft design for the construction of bench-scale equipment with vacuum film evaporator (figure II/2)

The information was obtained through:

- an oral report,
- a principle flow sheet and a photograph.

Brief description of the equipment:

- Dimensions of the plant:
 - height approx. 6 m
 - length approx. 4 m
 - width approx. 1 m
- Equipment is mounted on a steel scaffold.
- Material: grade SUS 304 stainless steel (acc.DIN 1.4301)
- Overall dimensions of the vacuum film evaporator:
 - . diameter of the inner tube: 100 mm
 - . length of the evaporator: 2.5 to 3.0 m
- The vacuum (absolute pressure: 13.3 kPa = 100 mm Hg) shall be produced by a water jet pump.

- Between 50 and 100 kg of solvent n-hexane are evaporated per hour and shall be condensed with water in the water jet pump.

For the following reasons, the consultant expressed his serious doubts of the operativeness of the vacuum system:

- The hourly output of n-hexane vapours is too high to allow for obtaining the required vacuum with a standard-size water jet pump operating at the normal flow rate. Hence, the n-hexane vapours will have to be condensed upstream the water jet pump.
- The difference of level between the water jet pump (figure II/2, item 5) and the vessels (figure II/2, items 6 and 7) is too small to ensure the steady operation of the vacuum system. The downpipe of the water jet pump is to be barometrically (height > 10 m) immersed in a receiver.
- As a working medium, water jet pumps require high water flow rates per hour. The strong turbulence prevailing in this apparatus makes it difficult to separate the condensed n-hexane from the water in a separator.
- The water circulation pump (figure II/2, item 8) transfers friction heat to the water. It has to be secured that this heat is removed from the system by cooling with a sufficient quantity of cold water.

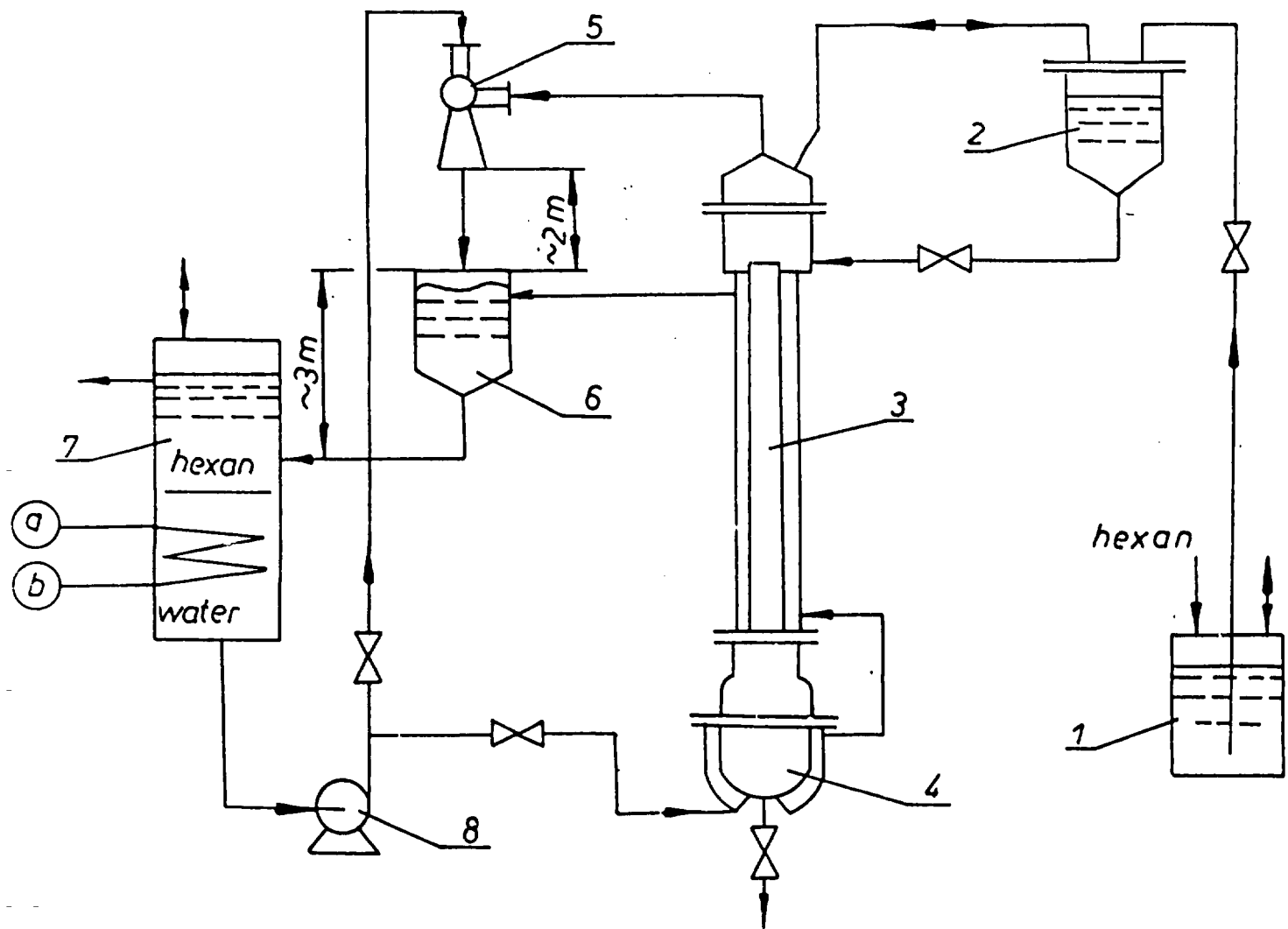

Desinagitions:

- 1 - vessel
- 2 - vessel
- 3 - filmevaporator
- 4 - vessel
- 5 - water vac.pump
- 6 - vessel
- 7 - separator
- 8 - water pump
- a,b-cooling water (10-25 °C)

UNIDO/88/Langner/figII/2
 Principle flow sheet, film evaporator

B. Discussion of problems and suggested improvements on equipment comprising vacuum film evaporators

Extraction

The crucial question at this stage of the technological process is to find the right solvent of guaranteed quality (none of the components should feature a higher boiling point) that permits of obtaining high-quality essential oils. The consultant informed that

- in Bulgaria petroleum ether is used for the extraction of rose oil and
- China imports the n-hexane in order to guarantee the required quality.

The P.E.O.R.C. informed that

- n-hexane was chosen as a solvent since
 - . it is produced in the D.P.R of Korea on a commercial scale and
 - . other countries (China, Japan) are using it for the extraction of oils from flowers, too;
- at the manufacturing chemist's this solvent is distilled three times at column top temperatures that are equivalent to the boiling point of pure n-hexane;
- in spite of the last-mentioned fact, however, about 1.5 kg of non-evaporating matter (paraffin and other compounds) remain in the still after the evaporation of 1000 kg of n-hexane produced in the manner described before;

- the n-hexane is not subjected to gas-chromatographic analyses for quality control.

The consultant recommends:

- to introduce the gas-chromatographic control of the quality of the n-hexane and
- to compare the quality of the Korean n-hexane with that of n-hexane from abroad, e.g. from Japan.

Removal of the solvent and its traces from the "concrete" essential oil

As reported in subsection II.A.2, both the process, which comprises three stages, and the equipment were developed by the P.E.O.R.C. on a laboratory scale. The possibilities of optimizing said process, its stages and the equipment were discussed.

a) Vacuum film evaporation

The P.E.O.R.C. let know that temperatures between 25 and 30 °C are the admissible maximum in the film evaporator (heating water temperature). Product quality would be deteriorated, if this limit value was exceeded. The consultant remarked

- that the reason for limiting the film evaporator temperature is the relatively long period which the product resides in the vessel below the evaporator after evaporation and

- that the above-mentioned temperature limit makes it impossible to intensify the film evaporation process and to reduce the solvent concentration in the "concrete" oil to 5 percent in weight or less, owing to the necessity of keeping the melting point of the mixture below 25 oC in order to prevent the film evaporator from being stopped up with solid product.

The consultant's question as to whether batch vacuum distillation had already been applied instead of vacuum film evaporation, to remove the major part of the solvent, was answered by the P.E.O.R.C. in the affirmative, stating that in the latter case product quality had been inferior.

b) Batch vacuum distillation

The consultant is of the opinion that the application of batch vacuum distillation is not the optimum solution for this stage of the process. He suggests

- to use a rotary vacuum film evaporator,
- to operate said evaporator at temperatures above the melting point of the "concrete" oil (> 40 oC) and
- to introduce the product, right after leaving said evaporator, into a cold liquid such as ethanol, in order to exclude its thermal decomposition.

c) Freeze-drying

This method is original and it guarantees that the essential oil loses only a minimum of its components

while the traces of solvent are being removed from it, because the partial pressure difference between solvent and essential oil increases with decreasing temperature.

The method of removing the n-hexane traces by mixing the essential oil with ethanol and evaporating the ethanol/n-hexane mixture afterwards has two disadvantages:

- It is necessary to separate the ethanol from the n-hexane after evaporation.
- Some residual ethanol will be left in the essential oil.

With industrial plants it will be reasonable to erect the equipment of process stage (a) in the vicinity of the plant habitats or fields, in order to avoid long haulage distances for the great quantities of solvent. The equipment of stages (b) and (c) should be centralized since

- the quantities of product to be transported are small,
- an exact product quality control at this stage is indispensable and
- processing is independent of the harvesting season of the flowers.

Production of "absolute" essential oil on the basis of "concrete" oil

According to the P.E.O.R.C., the fundamental problem in this process is to separate the wax from the essential oil to the greatest possible extent. Wax residues in the perfume would stain the clothes and must be excluded. Possible solutions to this problem are:

- to let the filtration process take place at low temperature (of about -20 °C) and
- to use efficient filtering paper (imported from France).

The P.E.O.R.C. presented the design of a filter for low-temperature operation (see figure II/3).

C. Elaboration of the technical specification for a vacuum film evaporator

The task specified in Annex 5 (tender specification) is the result of team work between the P.E.O.R.C. and the consultant.

In the essential, this team work aimed at creating highly reliable equipment and possibly excluding all doubts of its operativeness expressed in subsection II.A.4. The above-mentioned specification constitutes the basis for the procurement of offers from foreign enterprises for the delivery of bench-scale equipment with vacuum film evaporators. After the delivery, erection and successful trial operation of the equipment by the P.E.O.R.C., the D.P.R. of Korea, would like to start the local construction of such equipment for industrial purposes.

The consultant had expressed the opinion that the financial means included in the project (10000,- US \$) are much too small for the scope of equipment listed in the specification. That is why the P.E.O.R.C. decided the following priorities for individual equipment (fig. annex 5/1):

1. film evaporator E 1 + V 3
2. condenser C 1
3. refrigerating set R 1
4. mechanical vacuum pump, 1 unit P1
5. vessels V 2, V 4, V 5, V 6
6. all valves and the automatic control circuits PIC, LIC

III. EQUIPMENT AND TECHNOLOGY FOR THE PRODUCTION OF ESSENTIAL OILS BY STEAM OR WATER DISTILLATION

A. Stage of development achieved in the D.P.R. of Korea

Today steam distillation is the most frequently applied method for the production of essential oils from vegetable raw materials in Korea. Used for the production of the oils are such plants as

- pine (Pinus sp.)
- thuja (Thuja koraiensis)
- calmus (Acorus asiaticus)
- peppermint (Mentha arvensis var. piperascens)
- nepeta (Nepeta cataria)
- valerian (Valeriana fouieri).

Statistical values of the produced quantities of oil are not available. The Korean experts estimate the annual output of peppermint oil at 100 tonnes. A total of 700 tonnes of various oils from wild plants (such as pine, thuja etc.) are said to be manufactured annually in the northern region of the country.

In the D.P.R. of Korea there are about 3000 to 4000 small-scale stills of local importance for the production of essential oils by steam distillation. On the average, the volumes of the distilling tanks range from 250 to 300 l. The capacity of the biggest amounts to 500 l. The tanks are preferably by direct steam from a steam generator. They are neither provided with heating jackets nor with coils. Some of the stills are directly fuelled in the traditional way. The raw materials are manually

charged and discharged, after opening the lid of the tank.

Equipment fitted with modern charging and discharging facilities (tilting tanks, tanks provided with baskets) are only found in a district town named County. Two types of condensers operating with cooling water are used for the condensation of vapours, i.e.

- spiral condensers for distillation tanks of capacities between 250 and 300 l and
- plate condensers for the 500 l tanks (see figure III/1).

B. Information about modern, advanced equipment.

The consultant gave the following information on up-to-date steam distillation equipment:

EYSSERIC Company/France

Address: Ets F. EYSSERIC & Fils, 26110 NYONS

For more than 50 years this company has been experienced in essential oil distilling plants, having available stills with capacities of 1450, 2500 and 5000 l.

Incorporated into the 2500 and 5000 litre stills are

- medium and high-capacity distilling apparatuses with prefabricated furnace, steam boiler and chimney;
- standardized low-pressure water-bath steam generators;
- cooling units comprising a spiral condenser and an oil separator;

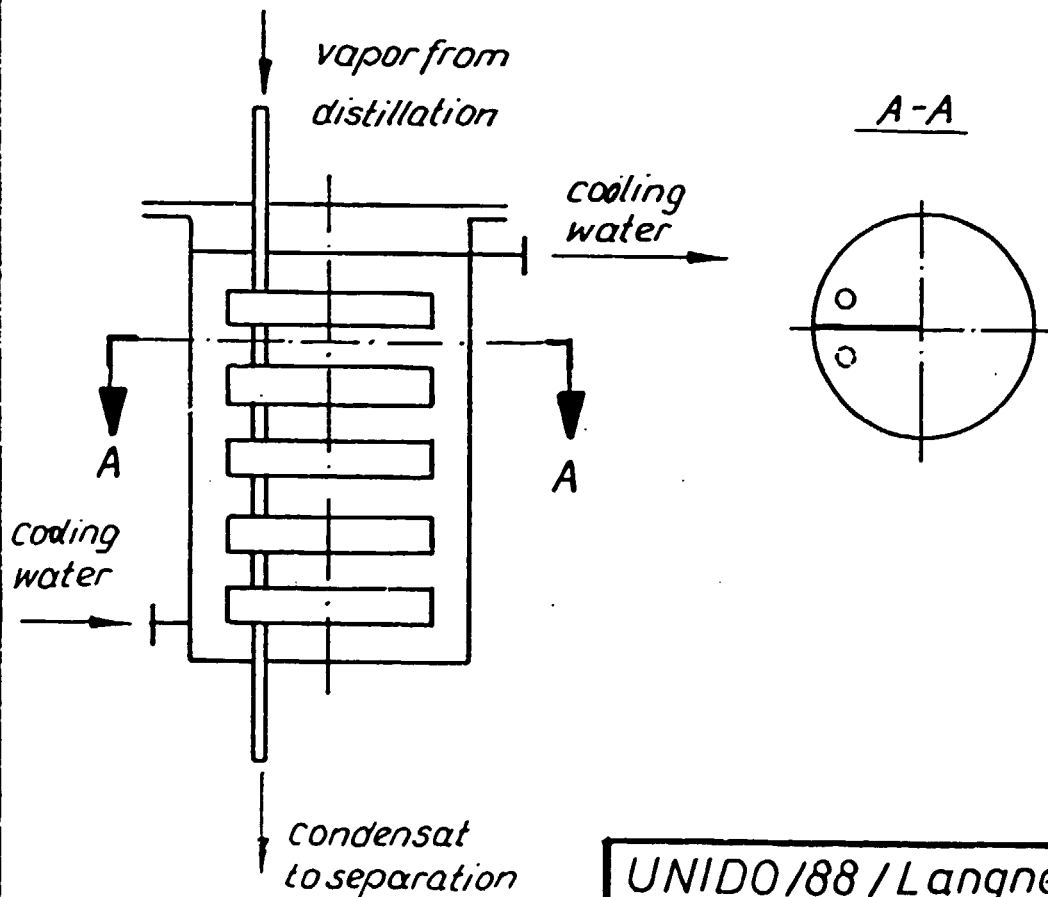
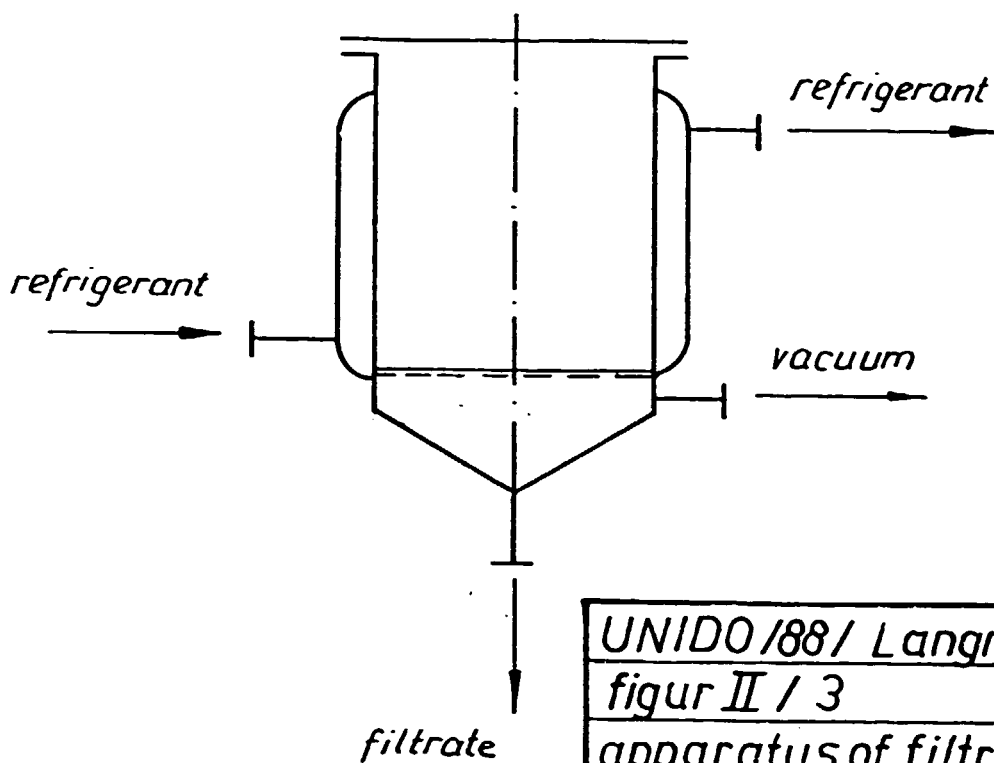

UNIDO/88 / Langner
figur III / 1
condenser

- process measuring and control equipment such as pressure gauges, level indicators, valves, pump controls etc.;
- auxiliary structures such as operating platforms, ramps, ladders etc..

Incorporated into the 1450 litre stills are

- individual apparatuses for small business;
- steam generators built into composite furnaces fuelled with wood or distillation residues;
- boxed for foreign shipment;
- options for exports: chimney, floor, ladder, shed, gantry.

Up-to-date industrial plants and equipment for steam or water distillation are in operation in the following countries:

a) Hungary, Szilasmenti Mezogasbasagi termeloszovetkezet
Kerepestarosa

- steam distillation of camomile, lavender, peppermint, caraway, dill etc.

b) Bulgaria, Bulgarska rosa in Karavelavo near Karlovo

- water distillation of rose flowers
- steam distillation of lavender

c) G.D.R., VEB Kosmetikkombinat Berlin in collaboration
with other companies

- steam distillation of peppermint, caraway, dill, marjoram, lovage, parsley etc.

The main characteristics of these plants and equipment are given in table no. 1.

Additional information can be obtained from the following figures:

- figure II/2 Stationary steam distillation unit
- figure III/3 Mobile steam distillation container
- figure III/4 Station for steam distillation with mobile container
- figure II/5 Separator

59012 W Freiberg, Aufhess. Beschränkt. 307/77 III/2/5/4 62/3 63/3 64/3 65/3 66/3 67/3 68/3 69/3 70/3 71/3 72/3 73/3 74/3 75/3 76/3 77/3 78/3 79/3 80/3 81/3 82/3 83/3 84/3 85/3 86/3 87/3 88/3 89/3 90/3 91/3 92/3 93/3 94/3 95/3 96/3 97/3 98/3 99/3 100/3 101/3 102/3 103/3 104/3 105/3 106/3 107/3 108/3 109/3 110/3 111/3 112/3 113/3 114/3 115/3 116/3 117/3 118/3 119/3 120/3 121/3 122/3 123/3 124/3 125/3 126/3 127/3 128/3 129/3 130/3 131/3 132/3 133/3 134/3 135/3 136/3 137/3 138/3 139/3 140/3 141/3 142/3 143/3 144/3 145/3 146/3 147/3 148/3 149/3 150/3 151/3 152/3 153/3 154/3 155/3 156/3 157/3 158/3 159/3 160/3 161/3 162/3 163/3 164/3 165/3 166/3 167/3 168/3 169/3 170/3 171/3 172/3 173/3 174/3 175/3 176/3 177/3 178/3 179/3 180/3 181/3 182/3 183/3 184/3 185/3 186/3 187/3 188/3 189/3 190/3 191/3 192/3 193/3 194/3 195/3 196/3 197/3 198/3 199/3 200/3 201/3 202/3 203/3 204/3 205/3 206/3 207/3 208/3 209/3 210/3 211/3 212/3 213/3 214/3 215/3 216/3 217/3 218/3 219/3 220/3 221/3 222/3 223/3 224/3 225/3 226/3 227/3 228/3 229/3 230/3 231/3 232/3 233/3 234/3 235/3 236/3 237/3 238/3 239/3 240/3 241/3 242/3 243/3 244/3 245/3 246/3 247/3 248/3 249/3 250/3 251/3 252/3 253/3 254/3 255/3 256/3 257/3 258/3 259/3 260/3 261/3 262/3 263/3 264/3 265/3 266/3 267/3 268/3 269/3 270/3 271/3 272/3 273/3 274/3 275/3 276/3 277/3 278/3 279/3 280/3 281/3 282/3 283/3 284/3 285/3 286/3 287/3 288/3 289/3 290/3 291/3 292/3 293/3 294/3 295/3 296/3 297/3 298/3 299/3 300/3 301/3 302/3 303/3 304/3 305/3 306/3 307/3 308/3 309/3 310/3 311/3 312/3 313/3 314/3 315/3 316/3 317/3 318/3 319/3 320/3 321/3 322/3 323/3 324/3 325/3 326/3 327/3 328/3 329/3 330/3 331/3 332/3 333/3 334/3 335/3 336/3 337/3 338/3 339/3 340/3 341/3 342/3 343/3 344/3 345/3 346/3 347/3 348/3 349/3 350/3 351/3 352/3 353/3 354/3 355/3 356/3 357/3 358/3 359/3 360/3 361/3 362/3 363/3 364/3 365/3 366/3 367/3 368/3 369/3 370/3 371/3 372/3 373/3 374/3 375/3 376/3 377/3 378/3 379/3 380/3 381/3 382/3 383/3 384/3 385/3 386/3 387/3 388/3 389/3 390/3 391/3 392/3 393/3 394/3 395/3 396/3 397/3 398/3 399/3 400/3 401/3 402/3 403/3 404/3 405/3 406/3 407/3 408/3 409/3 410/3 411/3 412/3 413/3 414/3 415/3 416/3 417/3 418/3 419/3 420/3 421/3 422/3 423/3 424/3 425/3 426/3 427/3 428/3 429/3 430/3 431/3 432/3 433/3 434/3 435/3 436/3 437/3 438/3 439/3 440/3 441/3 442/3 443/3 444/3 445/3 446/3 447/3 448/3 449/3 450/3 451/3 452/3 453/3 454/3 455/3 456/3 457/3 458/3 459/3 460/3 461/3 462/3 463/3 464/3 465/3 466/3 467/3 468/3 469/3 470/3 471/3 472/3 473/3 474/3 475/3 476/3 477/3 478/3 479/3 480/3 481/3 482/3 483/3 484/3 485/3 486/3 487/3 488/3 489/3 490/3 491/3 492/3 493/3 494/3 495/3 496/3 497/3 498/3 499/3 500/3 501/3 502/3 503/3 504/3 505/3 506/3 507/3 508/3 509/3 510/3 511/3 512/3 513/3 514/3 515/3 516/3 517/3 518/3 519/3 520/3 521/3 522/3 523/3 524/3 525/3 526/3 527/3 528/3 529/3 530/3 531/3 532/3 533/3 534/3 535/3 536/3 537/3 538/3 539/3 540/3 541/3 542/3 543/3 544/3 545/3 546/3 547/3 548/3 549/3 550/3 551/3 552/3 553/3 554/3 555/3 556/3 557/3 558/3 559/3 560/3 561/3 562/3 563/3 564/3 565/3 566/3 567/3 568/3 569/3 570/3 571/3 572/3 573/3 574/3 575/3 576/3 577/3 578/3 579/3 580/3 581/3 582/3 583/3 584/3 585/3 586/3 587/3 588/3 589/3 590/3 591/3 592/3 593/3 594/3 595/3 596/3 597/3 598/3 599/3 600/3 601/3 602/3 603/3 604/3 605/3 606/3 607/3 608/3 609/3 610/3 611/3 612/3 613/3 614/3 615/3 616/3 617/3 618/3 619/3 620/3 621/3 622/3 623/3 624/3 625/3 626/3 627/3 628/3 629/3 630/3 631/3 632/3 633/3 634/3 635/3 636/3 637/3 638/3 639/3 640/3 641/3 642/3 643/3 644/3 645/3 646/3 647/3 648/3 649/3 650/3 651/3 652/3 653/3 654/3 655/3 656/3 657/3 658/3 659/3 660/3 661/3 662/3 663/3 664/3 665/3 666/3 667/3 668/3 669/3 670/3 671/3 672/3 673/3 674/3 675/3 676/3 677/3 678/3 679/3 680/3 681/3 682/3 683/3 684/3 685/3 686/3 687/3 688/3 689/3 690/3 691/3 692/3 693/3 694/3 695/3 696/3 697/3 698/3 699/3 700/3 701/3 702/3 703/3 704/3 705/3 706/3 707/3 708/3 709/3 710/3 711/3 712/3 713/3 714/3 715/3 716/3 717/3 718/3 719/3 720/3 721/3 722/3 723/3 724/3 725/3 726/3 727/3 728/3 729/3 730/3 731/3 732/3 733/3 734/3 735/3 736/3 737/3 738/3 739/3 740/3 741/3 742/3 743/3 744/3 745/3 746/3 747/3 748/3 749/3 750/3 751/3 752/3 753/3 754/3 755/3 756/3 757/3 758/3 759/3 760/3 761/3 762/3 763/3 764/3 765/3 766/3 767/3 768/3 769/3 770/3 771/3 772/3 773/3 774/3 775/3 776/3 777/3 778/3 779/3 780/3 781/3 782/3 783/3 784/3 785/3 786/3 787/3 788/3 789/3 790/3 791/3 792/3 793/3 794/3 795/3 796/3 797/3 798/3 799/3 800/3 801/3 802/3 803/3 804/3 805/3 806/3 807/3 808/3 809/3 810/3 811/3 812/3 813/3 814/3 815/3 816/3 817/3 818/3 819/3 820/3 821/3 822/3 823/3 824/3 825/3 826/3 827/3 828/3 829/3 830/3 831/3 832/3 833/3 834/3 835/3 836/3 837/3 838/3 839/3 840/3 841/3 842/3 843/3 844/3 845/3 846/3 847/3 848/3 849/3 850/3 851/3 852/3 853/3 854/3 855/3 856/3 857/3 858/3 859/3 860/3 861/3 862/3 863/3 864/3 865/3 866/3 867/3 868/3 869/3 870/3 871/3 872/3 873/3 874/3 875/3 876/3 877/3 878/3 879/3 880/3 881/3 882/3 883/3 884/3 885/3 886/3 887/3 888/3 889/3 890/3 891/3 892/3 893/3 894/3 895/3 896/3 897/3 898/3 899/3 900/3 901/3 902/3 903/3 904/3 905/3 906/3 907/3 908/3 909/3 910/3 911/3 912/3 913/3 914/3 915/3 916/3 917/3 918/3 919/3 920/3 921/3 922/3 923/3 924/3 925/3 926/3 927/3 928/3 929/3 930/3 931/3 932/3 933/3 934/3 935/3 936/3 937/3 938/3 939/3 940/3 941/3 942/3 943/3 944/3 945/3 946/3 947/3 948/3 949/3 950/3 951/3 952/3 953/3 954/3 955/3 956/3 957/3 958/3 959/3 960/3 961/3 962/3 963/3 964/3 965/3 966/3 967/3 968/3 969/3 970/3 971/3 972/3 973/3 974/3 975/3 976/3 977/3 978/3 979/3 980/3 981/3 982/3 983/3 984/3 985/3 986/3 987/3 988/3 989/3 990/3 991/3 992/3 993/3 994/3 995/3 996/3 997/3 998/3 999/3 1000/3

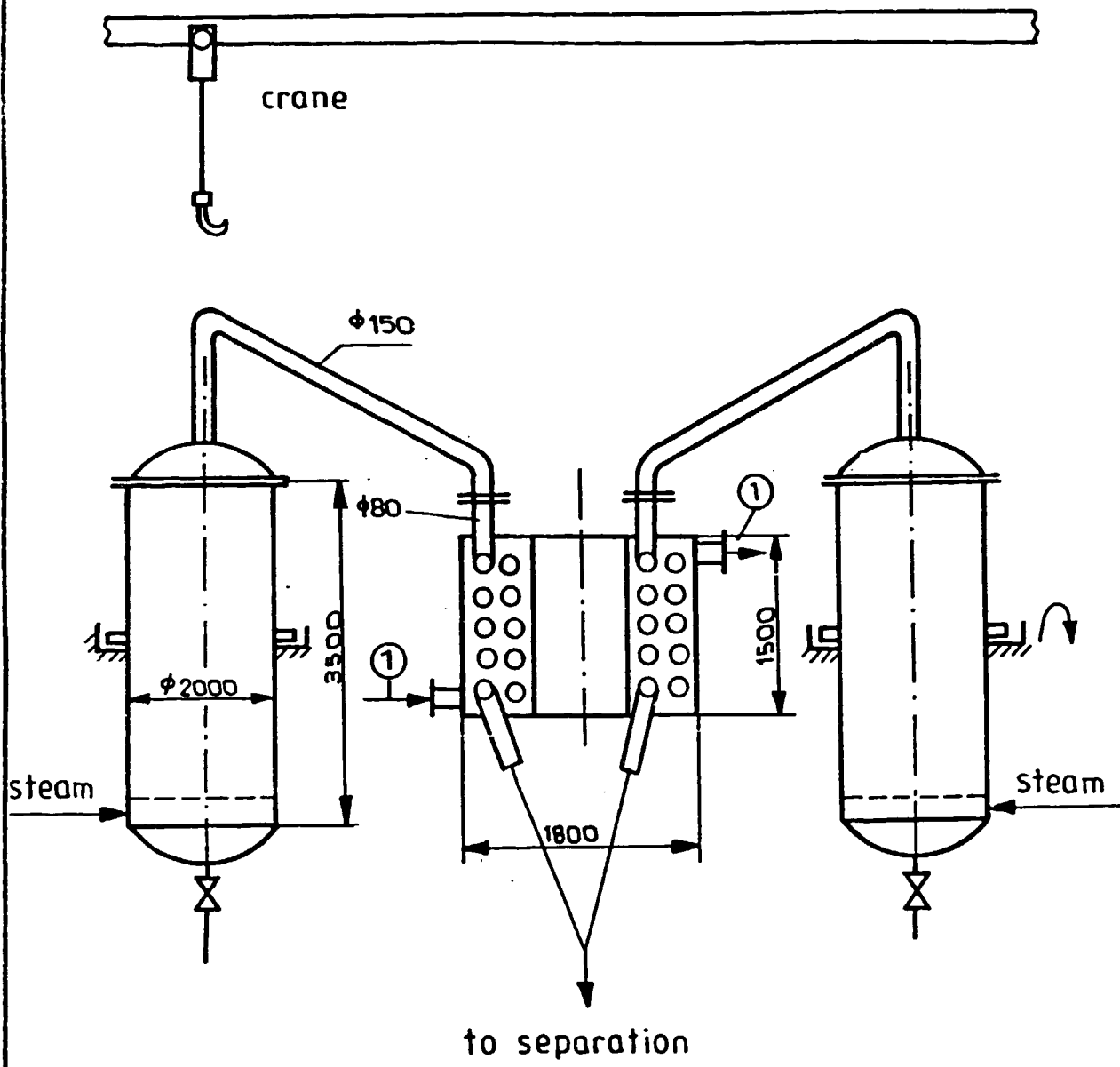

① - cooling water

UNIDO/88/ Langner
Figur III/2, stationary
steam distillation unit

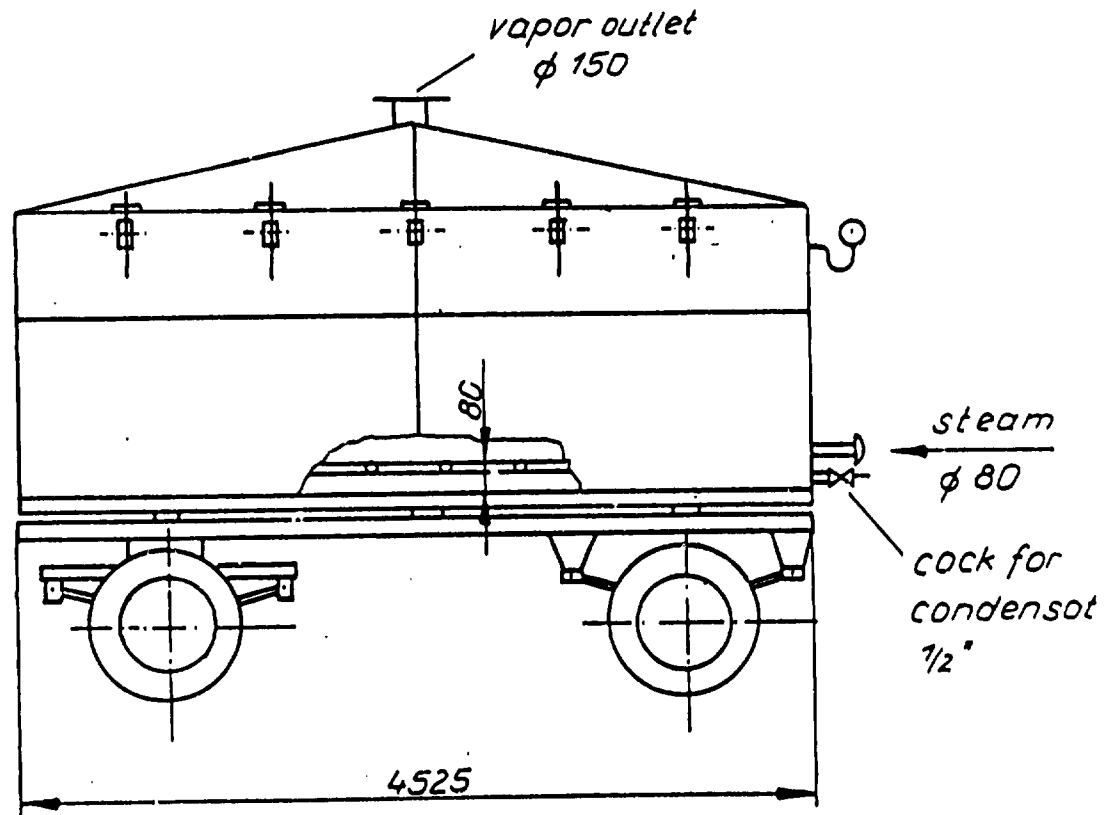
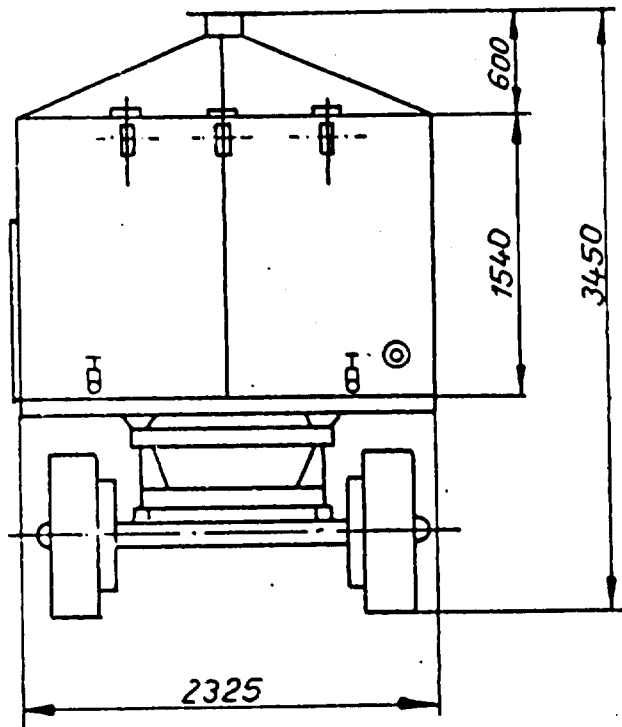

distributor
of steam
(tubes $\phi 50$):

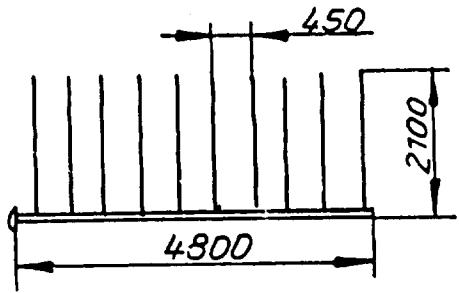

UNIDO/88/Langner
figur III/3, mobile steam
distillation container

scale 1:1000

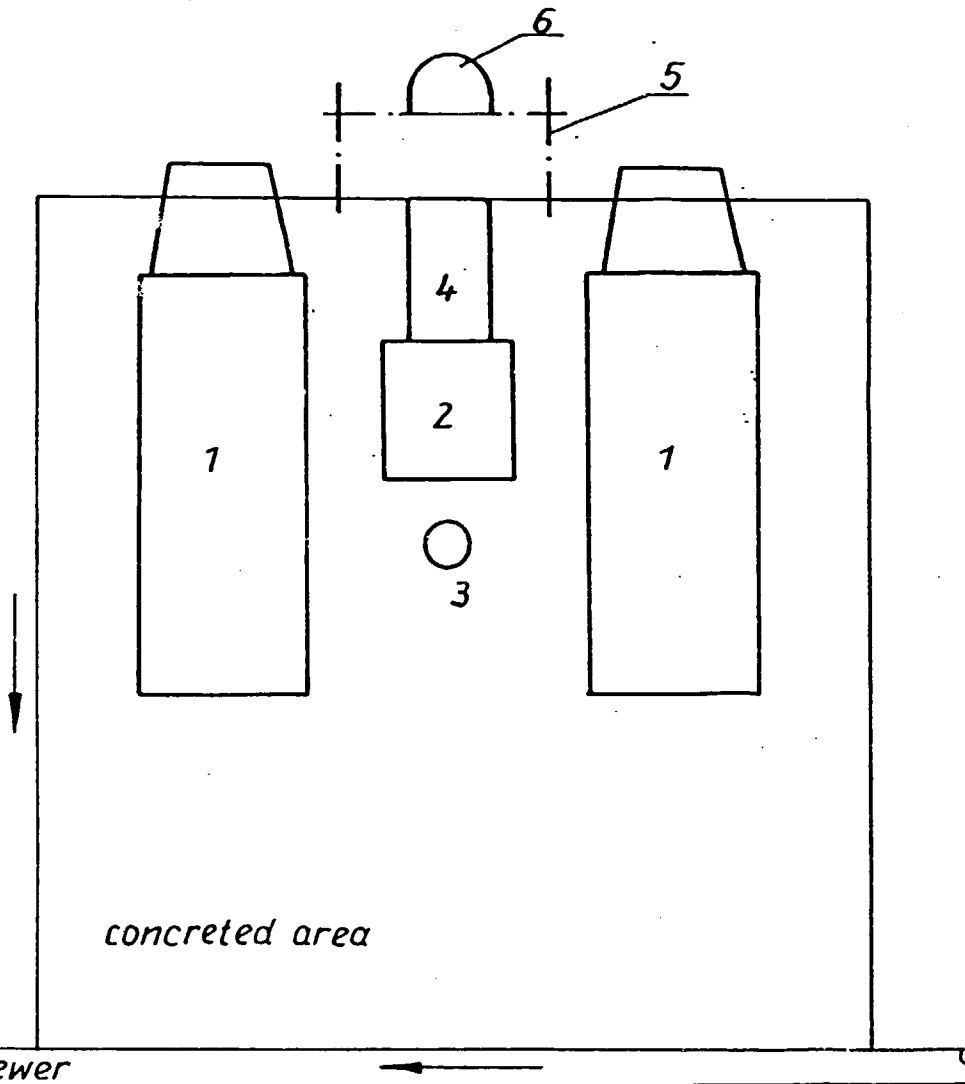

1- mobile containers

2- condenser with coils

3- separator

4- reducing and distribution of steam

5- framework

6- ladder

UNIDO/88/Langner

fig. III/4, station for steam

distillation in mobile containers

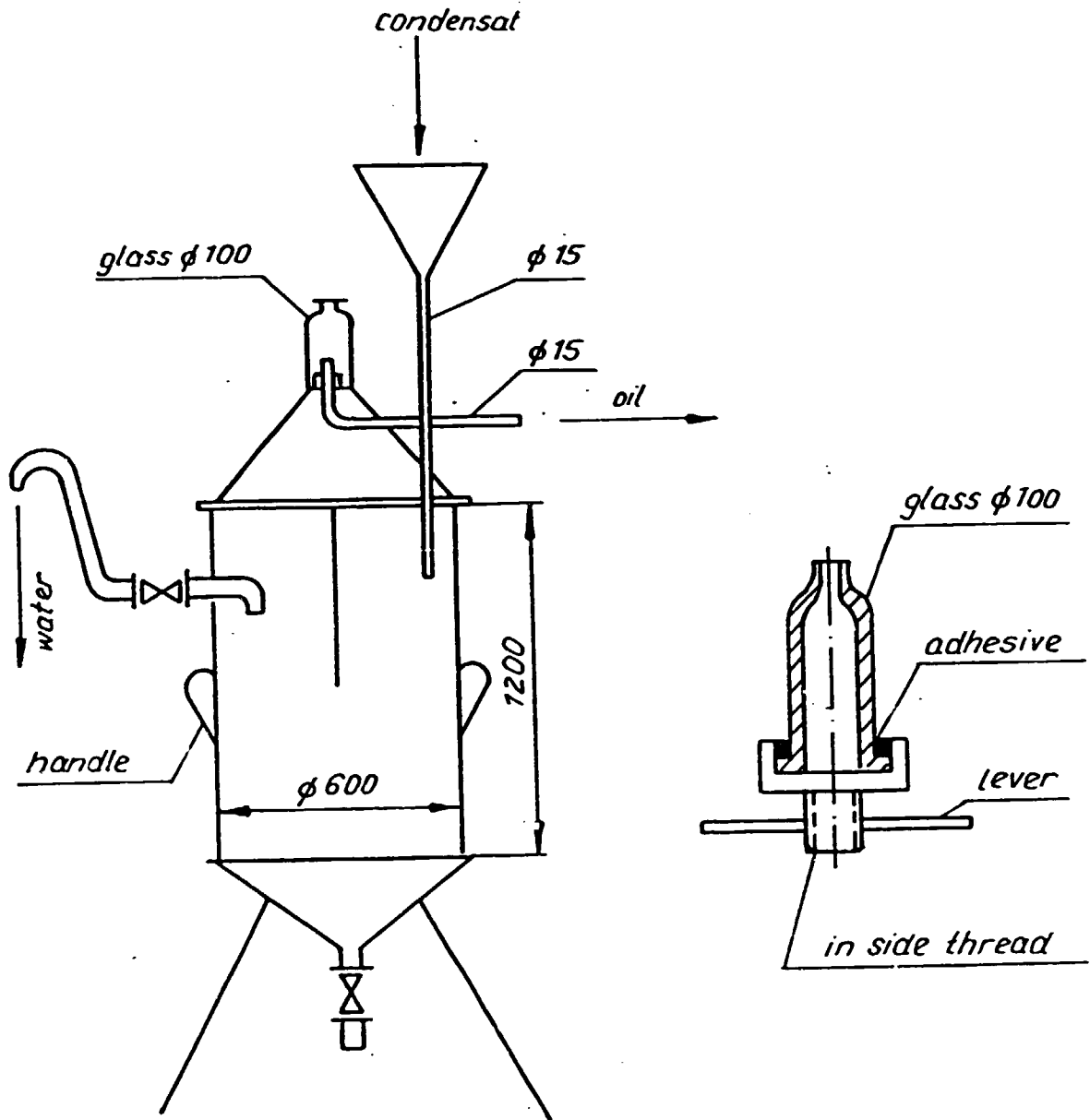

UNIDO/88/ Langner
fig. III/5
mobile separator

Table No. 1: Characteristics of some steam/water distillation plants

Plant symbol	Design	Number of distilling tanks	Tank volume (m ³) or dimens.	Raw materials handling technology		Condenser type	Remarks
				Charging	Discharging		
a	stationary	11	4	conveyor belt	hydraulic tilting	spiral condenser	- one condenser for two tanks of 4 m ³
		3	1	conveyor belt	in baskets		- one tank of 4 m ³ with shell tube condenser
		1		conveyor belt	in baskets		for seed granules only
	mobile	4	2.5 m (w) by 2.0 m (h) 6.0 m (l)	by harvester in the field	manually	spiral condenser	one condenser with two spirals for two containers
b	stationary	6	5 - 7	in baskets	in baskets	spiral condenser	condensed water conveyed from the separator to a cohabitation column to obtain the "secondary" oil
c	stationary	3	abt. 5	by belt conveyor	hydraulically tilting tank bottoms	shell tube condenser	1) after distillation the raw material remnants are discharged into vehicles (trailers or the like)
	mobile	2	2.3 m (w) by 2.0 m (h) 4.5 m (l)	by harvester	mechanically side-tilting	spiral condenser	(w) = wide (h) = high (l) = long)

C. Water distillation equipment and technology for the extraction of oil from the Rosa rugosa

The P.E.O.R.C. informed of the results obtained in the D.P.R. of Korea in applying the above method, pointing to the following two problems:

- Owing to the high solubility of Rosa rugosa oil in water, no oil phase was formed in the separator.
- Part of the Rosa rugosa flowers crumbled during the boiling process so that mud was formed. Mud formation depends on the thickness of the flower leaves. The leaves of sufficient strength (thickness) collected from a number of habitats showed no mud formation in water distillation.

The consultant gave the following literature-based information on distilling equipment and technologies for rose flowers:

- When charging the distilling tank, it is
- When charging the distilling tank, it is absolutely necessary to keep the prescribed water/flower ratio.
- At the initial stage of water distillation, the heating or evaporation rate shall be low so that the largest possible amount of "primary" oil can be obtained in the separator.
- Vapour condensation temperatures must not fall below 35 °C, in order to prevent some oil components from settling in the condenser.
- The condensed water in the separator contains a large number of dissolved oil components which have to be

recovered in a cohobation column. The oil recovered by cohobation is called "secondary" oil. After cohobation, the water is fed back into the process for the distillation of new flowers.

- Figure III/6 shows the suggestion of a modern water distillation tank.

Rosa rugosa oil production by water distillation has a number of advantages over the solid-liquid extraction with organic solvents. The process is simple and safe, producing high-quality "absolute" oil (free from traces of solvent or wax). And it is more economical than the extraction.

IV. BATCH VACUUM RECTIFICATION EQUIPMENT FOR ESSENTIAL OILS PROCESSING

A. Stage of development achieved in the D.P.R. of Korea

At present the essential oils produced by steam distillation are purified through dephlegmation at normal pressure, in simple stills without columns.

This purification process serves for

- improving the colour of the oils and
- removing the water and such oil components as feature a high boiling point, e.g. waxes, resins etc.

The stills have the following dimensions.

- Diameter: approx. 1.5 m
- Height (over vapour tube): 2.0 to 2.5 m

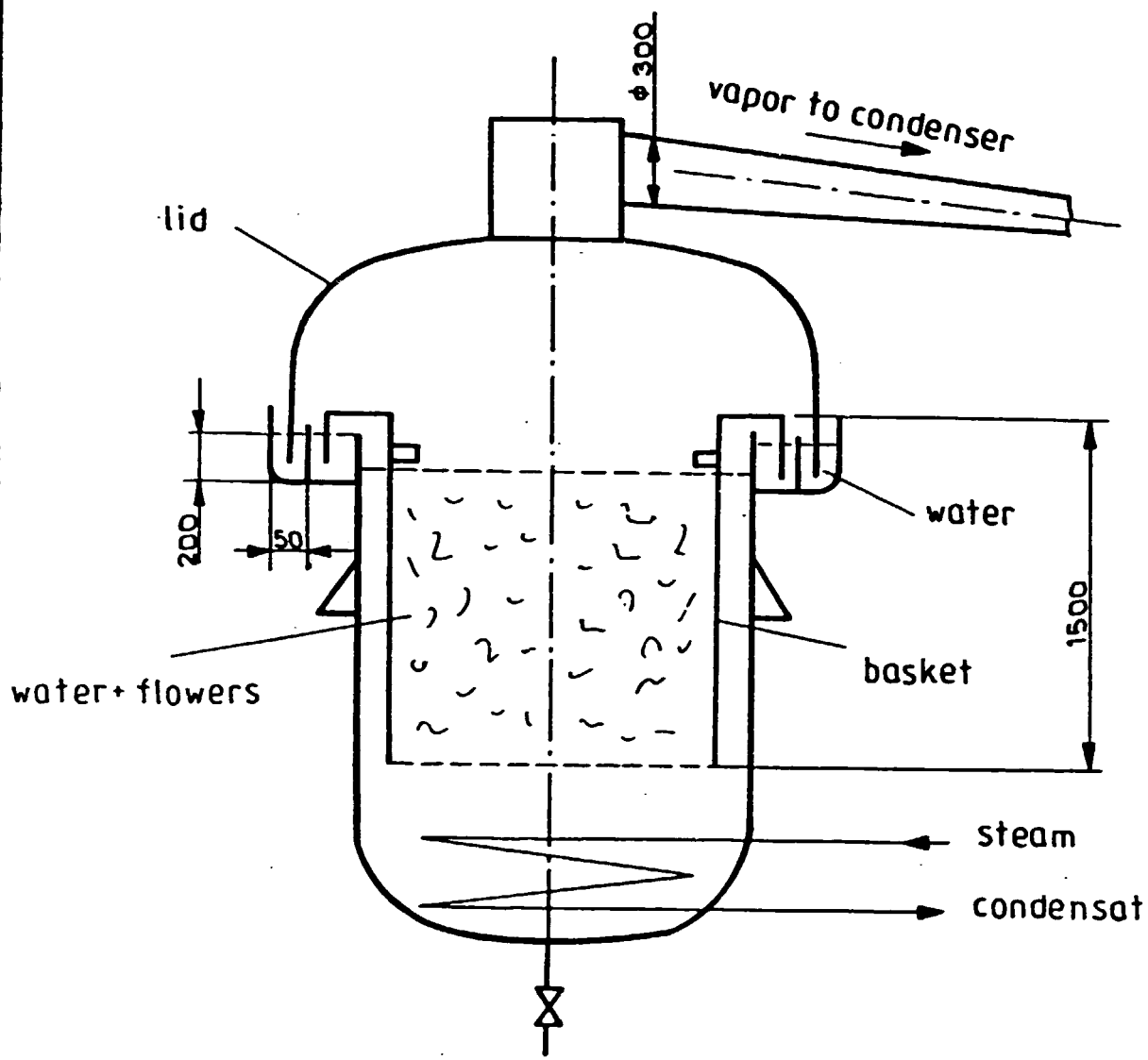

59012 W Freiberg, Abstraktanstelle Dresden III/15/4 2173/7 2174/7 2175/7 2176/7 2177/7 200,0 z/ D 30290

UNIDO/88/ Langner
Figur III/6 , water
distillation tank

They are provided with steam-heated coils in the bottom.

Normal-pressure boiling points and heating steam pressures for selected oils:

Oil	Boiling point (°C)	Absolute pressure of the heating steam (MPa)
Peppermint	140 - 160	0.4 - 0.65
Pine needles)		
Calamus)	80 - 120	0.1 - 0.25
Thuja)		

The yield of oil purified in this process is about 95 %.

At a P.E.O.R.C. trial station there is a batch vacuum rectification unit of the following features.

- Material: glass
- Still volume: 100 l
- Column diameter: 0.2 m
- Column height: 1.5 m
- Packing material: Raschig rings
- Absolute pressure: abt. 13.3 kPa = 100 mm Hg

B. The international state of art, presented by the example of some leading firms

The consultant explained the construction and functioning of modern batch vacuum rectification plant, informing of his experience in the operation of such equipment with the following features.

- The distilling kettle is heated with steam or an organic heat transfer medium. For thermolabile products it is either of shallow design or equipped with a falling film evaporator.
- The column is fitted with efficient packings on the basis of wire gauze that are particularly suited for vacuum operation and provide for
 - . a large number of theoretical trays and
 - . a low pressure drop per meter of column height.
- The total condenser is characterized by a low pressure drop and the absence of condensate undercooling.
- The reflux manifold allows for precise reflux ratio adjustments within a wide range.
- The product receiver is provided with cooling facilities.
- The vacuum generation system, which may be a combination of booster and water ring pump with automatic absolute pressure control, is highly reliable.
- The thermal output within the distilling kettle is controlled in dependence on the pressure drop between the bottom and the top of the column.

Tournaire from France has available various models or type series of such equipment.

Sulzer from Switzerland is famous mainly for its efficient column packings such as

- Sulzer BX (gauze of stainless steel or other material)
- Mellapak (made of metal)
- Kerapak (made of ceramic material).

VEB Chemianlag-~~n~~baukombinat Leipzig-Grinna / G.D.R. offers batch vacuum rectification plants for thermolabile substances, too. This company invented modern packings for vacuum columns up to 600 mm in diameter, named

Super Pyropack F and G,
and composed of wire gauze, cloth, metal sheet or foil.

The following is a list of some of their characteristic features.

Parameter	Super Pyropack G	Super Pyropack F
specific surface	500 to 700 m ² /m ³	
specific weight (stainless steel wire gauze)	150 kg/m ³	300 kg/m ³
recommended column diameter range	100 - 600 mm	100 mm or less
separative effect (number of theoretic- al trays per meter)	4 - 6	6 - 8
pressure drop	250 Pa/m	400 Pa/m
liquid hold-up	3 - 7 %	

On the basis of constructional drawings the consultant gave detailed information on a batch vacuum rectification plant with traditional packings, which the G.D.R. company VEB Komplette Chemieanlagen had exported to Cuba.

Some characteristic features of this system are given below.

- Kettle volume: abt. 200 l
- Column diameter: 150 mm
- Column height: abt. 10 m (incl. head condenser)
- Absolute pressure: 0.55 kPa = 4 mm Hg
- Heating medium: steam at 1.1 MPa (abs.pressure)
- Packing material: 10 mm ceramic Berl saddles

C. Elaboration of the technical specifications for modern bench-scale batch vacuum rectification equipment

The task (tender specification) formulated in Annex 6 is a result of the team work carried out by the P.E.O.R.C. and the consultant. The remarks made in section II.C. upon the purpose of the film evaporator specifications and the limitation of funds etc. apply to the present specifications, too. Hence, the consultant thinks it advisable to prioritize the intended applications as follows:

- processing of essential oils,
- final purification of the solvents and
- solvent recovery.

The scope of deliveries should be decided on the basis of these priorities.

V. OTHER QUESTIONS

On the 25th of November, 1988, the consultant visited the new P.E.O.R.C. building. (For the description of this building and the laboratories, please, refer to the report by Mr. Hylands, UNIDO consultant, dated

December 8, 1987). Having had a look into the room where the bench-scale unit with vacuum film evaporator is going to be installed, the consultant would recommend to check the equipment after its installation in said room, as the international safety regulations against explosion accidents (solvent n-hexane) inflict certain conditions, such as the application of

- a light-weight roof,
- an electrical system suitable for explosive gas atmospheres and
- a ventilation system,

which that room does not satisfy.

During the meetings held with the P.E.O.R.C., the consultant also informed of the up-to-date technology and equipment for supercritical gas extraction, predominantly using carbon dioxide. An experimental plant for the extraction of essential oils on this method is presently being tested in the G.D.R., on a laboratory scale, with such vegetable raw materials as marjoram, hop etc.

IV. CONCLUSIONS

1. The Korean intention to intensify scientific research into essential oils by establishing a research centre that shall form the basis for updating and strengthening the national essential oil industry is realistic and topical, because
 - this country possesses extensive resources of raw materials for the production of essential oils,
 - these substances and the final products made of them are urgently needed in both the home and the international market,
 - in the D.P.R. of Korea the facilities for series production of the necessary equipment for the essential oil industry are already available and
 - the Korean government concentrates the required material, labour and financial resources in this field.

2. In Korea, successful laboratory research work was done on the equipment for and the method of essential oil production by solid-liquid extraction from flowers (mainly of the *Rosa rugosa*) with organic solvents. Now the time has come to switch over to a bench-scale plant where efficient industrial equipment can be developed or selected for every stage in this process. The above-mentioned method and equipment, developed on a laboratory scale, is based on the right theoretical and experimental foundations. However, an optimization of the process seems to be possible.

Doubts were thrown upon the operativeness of the vacuum system on the P.E.O.R.C. design sheet for bench-scale plants with vacuum film evaporators.

Oil extraction by supercritical gases, in particular by carbon dioxide, is a process increasingly applied in the world. It has several advantages over other methods and is especially suited for thermolabile substances such as the essential oils extracted from flower leaves.

3. In the D.P.R. of Korea there are a number of small-sized essential oil plants of local importance that work on the steam distillation principle. These plants call for advancement in order to increase their capacity and productivity, extend the produced range of oils and improve the oil quality. Modern plants and equipment such as container-type steam distilling units for the extraction of oils from herbs should be created for that purpose.

The steam distillation process should be modified so that its advantages can be utilized for the purpose of *Rosa rugosa* oil extraction.

4. In Korea, the essential oils produced by steam distillation are purified today through simple dephlegmation at normal pressure without columns.

The incorporation of modern batch vacuum rectification columns into this process would not only allow for increased outputs and higher essential oil qualities. It would also enable the production of certain high-quality components of these oils.

5. Owing to the properties of n-hexane (fire and explosion hazard), the solid-liquid extraction with this solvent is not undangerous. Therefore, it is indispensable to observe all applicable safety regulations.

Annex 1

The senior counterpart staff, their names and specializations

Senior counterpart staff for scientifico-technical work:

- Choi Dung Gwang - Director of the P.E.O.R.C.
- Li Myong Ho - Head of the P.E.O.R.C. Laboratory,
acting as a guide for the consultant
- O Gwang Chol - Interpreter

Senior counterpart staff for fundamental questions:

- Yang Chang Hak - Director of the Department of
Science And Technology at the
Ministry of Light And Chemical
Industries
- Lim Gyong Man - Deputy Director-General of the 5th
Department of the Ministry of
Foreign Trade (MFT)
- Han Gang - Senior Officer of the 5th Depart-
ment of the Ministry of Foreign
Trade (MFT)
- Mr. Melder - Deputy Manager of the UNDP Office
in Pyongyang

Annex 2

BRIEFING NOTES FOR MR. LANGNER
DP/DRK/88/001/11-02. Chemical Design Engineer

Local Contact Institution: P.E.O.R.C.

Review and assess the nature of the equipment presently used in the centre for the production of essential oils.

- a) Can the designs be improved?
- b) Are there local facilities for construction of field distillation units?
- c) Investment possibilities for local construction if satisfactory -
 - The material required for construction of one or two model stills
 - Whether training is needed.

Discuss requirements with the local personnel concerning:

- i) Field distillation and stills (cap. 1000-2000 l)
- ii) Smaller stills for pilot scale work (cap. 500-1000 l)
- iii) Fractionating column assembly or rectification of essential oils 0.2 - 0.4 lit. cap.

Study all necessary details, materials, fuel, water, power. (To enable the consultant to submit details, designs and engineering specifications for local fabrication in i and ii above.

The consultant should bring a draft report outlining the factors to discuss at headquarters. Also, the consultant should bring design sketches for discussions.

After debriefing, the report and engineering designs could be finalised by the consultant at his home station and submit it to UNIDO for forwarding to the Government.

Vienna, 7 November, 1988

Annex 3

Time schedule of the activities

Individual activities in November/December, 1988:

- 06/11/88 Flight Berlin-Vienna
- 07/11/88 Briefing at UNIDO headquarters/Vienna
- 08/11/88-09/11/88 Flight Vienna-Rome-Beijing-Pyongyang
- 10/11/88-11/11/88 First contacts and meetings with the UNDP Office and the Korean partners
- 12/11/88-23/11/88 Meetings with the P.E.O.R.C. on the engineering design and technology of essential oil production
- 24/11/88-25/11/88 Preparation of the first draft of the report
- 28/11/88 Final meetings with representatives of the 5th department of the Ministry of Foreign trade and the UNDP Office
- 29/11/88 Flight Pyongyang-Moscow-Vienna
- 30/11/88-01/12/88 Debriefing at UNIDO headquarters in Vienna
- 02/12/88 Flight Vienna-Berlin

Annex 4

Addresses of foreign companies suggested for participation in
a tender for bench-scale equipment

- Tournaire/France

TOURNAIRE - S.A., Division equipements
BP4.06338 Le Plan des Grasse/France

- Sulzer/Switzerland

Gebrueder Sulzer Aktiengesellschaft
CH-8401 Winterthur, Schweiz

- VEB Komplette Chemieanlagen Dresden/G.D.R.

VEB Komplette Chemieanlagen Dresden
PSF 184
8012 Dresden/DDR

Annex 5

Specification for bench-scale equipment with vacuum film evaporator

1. Application of the equipment:

Removal of solvent n-hexane from the n-hexane/wax mixture by evaporation under vacuum and at low temperatures.

2. Capacity:

Capable of evaporating and condensing
50 kg of n-hexane per hour.

3. Brief description of the technology (fig. annex 5/1):

The n-hexane/wax mixture, contained in vessel V1 at atmospheric pressure, flows continuously into vessel V2 (stream 4) as a result of the vacuum. The liquid level in V2 is automatically controlled by the LC circuit. Owing to the difference in height, the mixture flows from V2 to the head of the evaporator E1 (stream 5). The flow rate is adjusted by hand with the aid of a precision vacuum valve or cock. In E1, the major part of the n-hexane is evaporated under vacuum. The vapours enter the condenser C1 (stream 6). The non-evaporated part of the n-hexane, including the wax, flows into the vessel V3. Warm water is used for heating E1 (streams 1a and 1b), the flow rate of which can be adjusted by hand on a precision valve. C1 condenses the n-hexane vapours, undercooling the condensate. It is cooled with refrigerant (streams 3a and 3b) from refrigeration set R1. The condensed n-hexane is collected in vessel V5, cooled with refrigerant via a coil (stream 7). V4 serves

as a buffer tank for the time when V5 is emptied. V6 is a safety separator for liquid and residual vapours. It is provided with a cooling jacket and a sight glass in the outlet. Absolute pressure is controlled automatically, by the PC circuit. One of the mechanical vacuum pumps is operating, while the other is at stand-by.

4. Technological parameters:

- Absolute pressure at the top of E1:
 - normal 13.3 kPa (= 100 mm Hg)
 - minimum 2.6 kPa (= 20 mm Hg)
- Wax concentration in the mixture (streams 4 and 5):
1.5 g/l
- Ambient temperatures:
 - summer mean: 25 °C, maximum: 30 to 33 °C
 - winter mean: -8 °C, minimum: -20 to -25 °C

Other parameters see Annex 5, No. 1.

5. List of equipment

- Vessel V1, provided by customer
- Vessel V2
 - . fluid: n-hexane/wax mixture
 - . volume: 250 l
 - . temperature: same as ambient
 - . pressure (abs.): 2.6 to 13.3 kPa
 - . material: stainless steel
 - . remarks: provided with lid for cleaning purposes, not high

- Vessel V3

. inner vessel
fluid: n-hexane/wax mixture
volume: 50 l
temperature: 25 to 60 oC
pressure (abs.): 2.6 to 13.3 kPa
material: grade SUS 304 stainless steel
(acc. DIN 1.4301)

. jacket
fluid: warm water
temperature: 25 to 60 oC
pressure (abs.): approx. 0.25 MPa
material: grade SUS 304 stainless steel
(acc. DIN 1.4301)

remarks:

. provided with illumination and sight glass in the lid
. temperature measurement in the bottom and pressure
measurement in the top section

- Vessel V4

fluid: n-hexane
volume: 30 l
temperature: -10 oC
pressure (abs.): 2.6 to 13.3 kPa
material: grade SUS 304 stainless steel
(acc. DIN 1.4301)

- Vessel V5

fluid: n-hexane
volume: 250 l
temperature: -10 oC
pressure (abs.): 2.6 to 13.3 kPa; 100 kPa
material: grade SUS 304 stainless steel
(acc. DIN 1.4301)

remarks:

- . provided with coil for refrigerant to be calculated by supplier
- . inspection glass provided in the side wall of the upper section
- . equipped with product temperature measuring facility

- Vessel V6

. inner Vessel

fluid: air, residual vapours of n-hexane
volume: 20 l
temperature: -10 oC
pressure (abs.): 2.6 to 13.3 kPa
material: grade SUS 304 stainless steel
(acc. DIN 1.4301)

. jacket

fluid: refrigerant
temperature:) to be decided by
pressure:) manufacturer
material: grade SUS 304 stainless steel
(acc. DIN 1.4301)

- Evaporator E1

heat transfer surface: to be calculated by supplier

. in the evaporator tube:

fluid: n-hexane/wax mixture
temperature: -5 to 60 oC
pressure (abs.): 2.6 to 13.3 kPa
material: grade SUS 304 stainless steel
(acc. DIN 1.4301)

in the jacket:
fluid: warm water
temperature: 25 to 60 oC
pressure (abs.): 0.25 MPa
material: grade SUS 304 stainless steel
(acc. DIN 1.4301)

remarks: Evaporator dimensions (diameter, height) can be calculated by supplier for the evaporation of pure n-hexane.

- Condenser C 1

heat transfer surface : to be calculated by supplier

. in the tubes:
fluid: n-hexane
temperature: -10 to 15 oC
pressure (abs.): 2.6 to 13.3 kPa
material: grade SUS 304 stainless steel
(acc. DIN 1:4301)

. in the jacket:
fluid: refrigerant
temperature: -10 oC at the inlet
pressure (abs.): to be determined by supplier
material: grade SUS 304 stainless steel
(acc. DIN 1.4301)

- Refrigerating set R 1

. capacity: to be calculated by supplier

- . refrigerant temperature at the inlet of C1: -10 oC

remarks:

- . refrigerant: ethylene glycol/water mixture, initial charge to be provided by supplier
- . refrigerating system complete with refrigerant circulating pump, expansion tank, piping etc.

- Mechanical vacuum pumps P1/1, P1/2

- . capacity: to be calculated by supplier
- . gas temperature: approx. -10oC
- . operating pressure (abs.): normal 2.6 to 13.3 kPa at the top section of E 1
min. to be calculated by supplier

remarks:

- . If it was necessary to warm up the gas/steam mixture before entering the pumps, the supplier should provide for an adequate solution (tube with warm water jacket or the like).
- . Check valves have to be installed upstream the vacuum pumps.

6. Further remarks

- All measuring and control instruments shall be installed in the plant, in-situ.
- Supply data:
 - . electric power: 60 Hz, 220 or 380 V

- . warm and cooling water: To be provided by customer. For specifications, see table in Annex 5, No. 1.
- . Steam and compressed air are not available.
- The equipment C1, V4, V5, V6 and R1 (in part) and the pipe connections between these units shall be provided with low temperature insulation.
- The electrical equipment (motors for R1, F1) and the LC and PC control circuits shall be of explosion-proof design. Precautions should be taken against electrostatic charging.
- The equipment shall be installed in two rooms arranged one above the other, each of which having a floor space of about 25 m³ and a height of about 3 m. Some openings for the equipment and piping may be provided in the ceiling (made of concrete) that separates the two rooms. In either room the equipment and other facilities shall be mounted on steel scaffolds or feet. Operating platforms shall be provided if necessary.
- The following is meant as an aid in film evaporator calculation.
An evaporator of the same shape, having
 - . an evaporation tube length of 1000 mm
 - . an evaporation tube diameter of 10 mmand working in similar conditions on a laboratory scale would evaporate
3.0 to 3.5 kg of n-hexane per hour.
- It is requested that the prices of individual equipment and documentation are quoted separately in the offer.

continued

Stream No.	Medium	Throughput (kg/h)			Temperature (C)			Absolute pressure (kPa)			Remarks
		min.	norm.	max.	min.	norm.	max.	min.	norm.	max.	
4	n-hexane/ wax	57	57	57	5)	5)	5)	2.6	atm. press.	atm. press.	5) ambient tem- perature
5	n-hexane/	57	57	57	5)	5)	5)	2.6	13.3	13.3	
6	n-hexane vapour	50	50	50	10	15	20	2.6	13.3	13.3	
7	liquid n-hexane	50	50	50	near -10	near -10	near -10	2.6	13.3	13.3	
8, 9	air & resid. vapours				near -10	near -10	near -10	2.6	13.3	13.3	

- Values not mentioned in the table above are to be calculated by supplier.
- The n-hexane/wax mixture is flowing from E1 to V3 at a rate of 7 kg/h.

Annex 6

Specification
for bench-scale equipment for batch vacuum rectification

1. Applications of the equipment

- Processing of natural essential oils such as of peppermint, thuja, calmus etc.
- Final cleaning of solvent, e.g. n-hexane

2. Capacity

abt. 40 l of liquid per batch.

3. Characteristic features of the equipment and the technology

The equipment shall be of similar design as the apparatuses shown in fig. annex 6/1.

- Dimensions:

- . diameter of the column: 150 mm
- . height of the column: max. 6400 mm
- . useful volume: abt. 40 l

- Heating system:

Electric (since customer has no steam supply system), using an organic heat transfer medium. Designed for a wide temperature range.

200 T/D 35/1/1

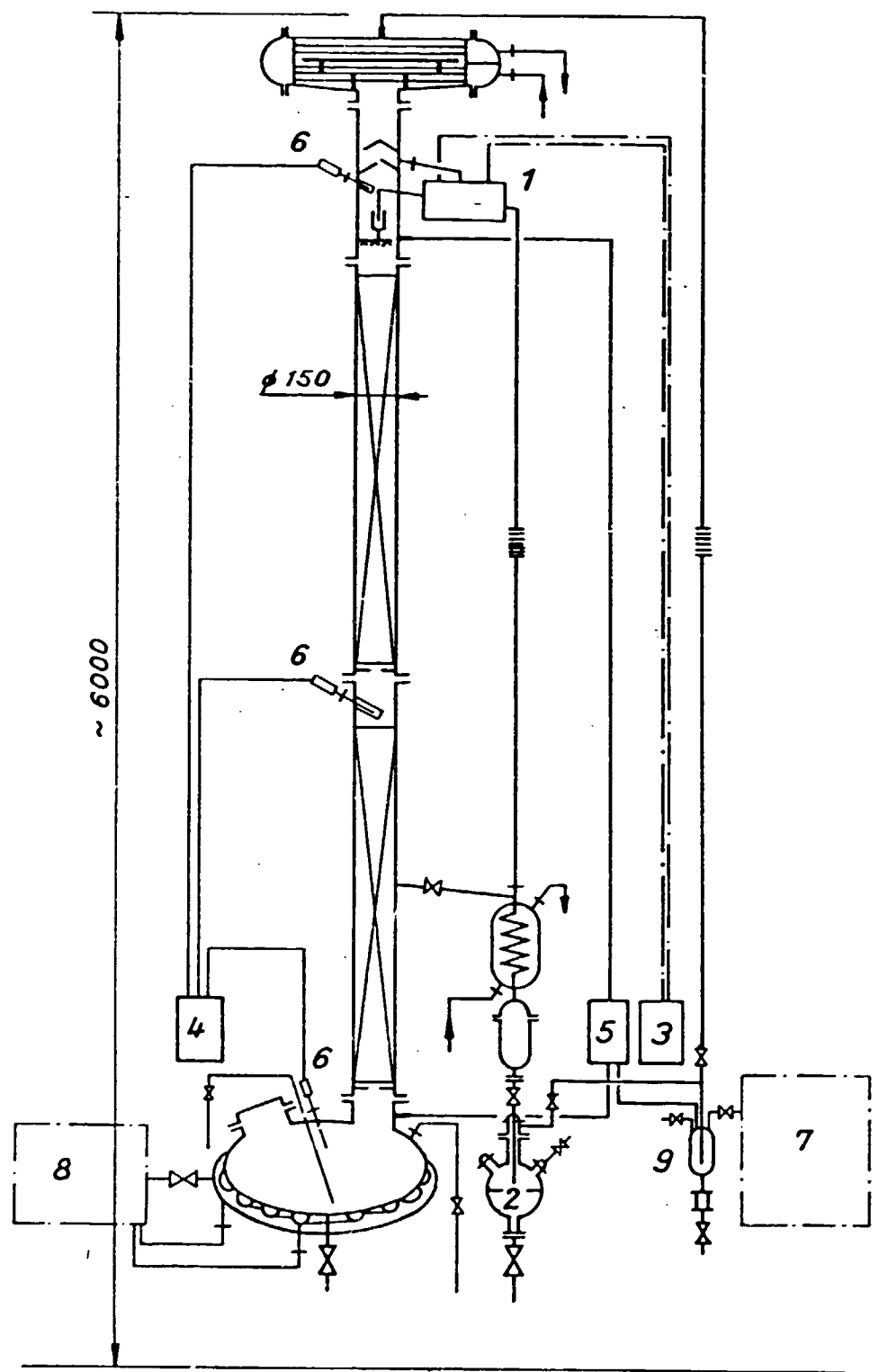

- 1 - reflux divider
- 2 - receiver
- 3 - control of reflux divider
- 4, 6 - indication of temperature
- 5 - indication of pressure
- 7 - generation of vacuum
- 8 - unit of heat generation with organic heat carrier
- 9 - separator

UNIDO/88 / Langner
 Figur annex 6/1, Batch
 vacuum distillation

59812 W Feuers. Abwasserbehandl. Dresden 4g 307/76 III/16/A 2140

- Vacuum generation:

By two mechanical vacuum pumps, one of which serving as stand-by.

- Maximum temperature of the product in the bottom of the distilling kettle:

- . for essential oils processing: 160 °C
- . for cleaning of the solvent: 70 °C

- Operating pressure (abs.) at the head of the column:

- . for essential oils processing: 0.67 to 13.3 kPa
- . for cleaning of the solvent: normal pressure

- Recommended distillation rate: abt. 30 to 40 kg/h, based upon water.

- Designed for the separation of components featuring a boiling point difference of 10 °C.

- Material: grade SUS 304 stainless steel (acc. DIN 1.4301)

- The reflux ratio shall be exactly adjustable within a wide range.

- All measuring and control instruments shall be installed in situ.

- Supply data:

- . electric power: 60 Hz, 220 or 380 V
- . cooling water: summer temperature range:
20 to 25 oC
winter temperature range:
10 to 15 oC
pressure (abs.): 0.25 MPa

. Steam and compressed air are not available.

- Any part of the system featuring a higher temperature shall be insulated.
- The electrical equipment and the measuring and control systems shall be of explosion-proof design. Electrostatic charging shall be excluded.
- The plant is going to be erected in the open air, next to the wall of a building of about 6 m in height. The apparatuses shall, therefore, be installed on a supporting steel structure provided with an operating platform.
- Type of packing:

10 mm ceramic Berl saddles or any other efficient traditional packing material; no modern column packings such as "Sulzer BX".
- The equipment (like the condenser, the vacuum pumps, etc.) shall be calculated by the supplier.

4. Remarks

Supplier is requested

- to quote separate prices for every type of equipment and for the documentation and
- to inform about the possibilities of modifying this plant in a way that would enable its utilization for another, third purpose: the evaporation of the n-hexane from the n-hexane/wax mixture (1.5 g of wax per litre), under vacuum and at low temperature.

In the affirmative case, this second variant of the plant should be designed as outlined hereinafter:

- . Warm-water (25-30 °C) heating shall be provided in the bottom of the distilling kettle.
- . n-hexane condensation at a temperature of -10 °C, by refrigerant circulating in a system that is fitted with a refrigerating set.
- . Condensate shall be cooled with refrigerant.
- . Operating pressure (abs.): 2.6 to 13.3 kPa
- In case the plant can be modified as specified above, supplier is requested to quote the additional price for said modification, taking into account that
 - . the warm water will be made available by customer and
 - . the refrigerating system shall be delivered complete with circulation pump, expansion vessel, piping, etc.