



**TOGETHER**  
*for a sustainable future*

## OCCASION

This publication has been made available to the public on the occasion of the 50<sup>th</sup> anniversary of the United Nations Industrial Development Organisation.



**TOGETHER**  
*for a sustainable future*

## DISCLAIMER

This document has been produced without formal United Nations editing. The designations employed and the presentation of the material in this document do not imply the expression of any opinion whatsoever on the part of the Secretariat of the United Nations Industrial Development Organization (UNIDO) concerning the legal status of any country, territory, city or area or of its authorities, or concerning the delimitation of its frontiers or boundaries, or its economic system or degree of development. Designations such as “developed”, “industrialized” and “developing” are intended for statistical convenience and do not necessarily express a judgment about the stage reached by a particular country or area in the development process. Mention of firm names or commercial products does not constitute an endorsement by UNIDO.

## FAIR USE POLICY

Any part of this publication may be quoted and referenced for educational and research purposes without additional permission from UNIDO. However, those who make use of quoting and referencing this publication are requested to follow the Fair Use Policy of giving due credit to UNIDO.

## CONTACT

Please contact [publications@unido.org](mailto:publications@unido.org) for further information concerning UNIDO publications.

For more information about UNIDO, please visit us at [www.unido.org](http://www.unido.org)

14827

DEVELOPMENT TRENDS IN THE ALUMINA PRODUCTION

by

Dr. János Zambó

Kingston, Jamaica  
June, 1985

3632

## DEVELOPMENT TRENDS IN THE ALUMINA PRODUCTION

AIME and ICSOBA meetings provide a good survey about the newest achievements of alumina production. The presentations on these meetings - concerning nearly every question of alumina production in detail - were published in the volumes of "Proc. of AIME Annual Meeting - Light Metals", "Alumina Until 2000. Proc. of ICSOBA Symposium, Tihany, Hungary, 1981", "Proc. of Bauxite Symp. J.Geol. Soc. of Jamaica No V. 1982" and in various "TRAVAUX" Volumes of ICSOBA. But overall studies are also not lacking (e.g. [1, 2, 3, 4] just to mention a few).

In the present paper, to be read upon your honourable invitation, - instead of enlisting the individual results of development - attempt is made to draw up the main trends of technical progress on the basis of the analysis of the present situation and the prospects of alumina production.

The alterations in aluminium production capacities, in production and consumption figures of the past decade, further the expectable data up to the early mineties are shown in Fig.1. The same data for alumina can be seen in Fig.2. In both cases the expected increases of the production capacity figures contain only plants under construction based on literature reports.

Fig.3 is a diagram of the various cost components of alumina production and Fig.4 is a comparison of these with bauxite and alumina prices. The data of 1963 and 1975 relate to alumina plants designed in those respective years, whilst the 1985 data are average values calculated from the effective data of 16 operating plants out of which 10 are older and 6 are new ones.

Fig.5 shows the change in specific investment costs, in rates of interest and in bauxite-, alumina- and fuel-oil prices, further two construction indices, covering the same period (1963 to 1985).

The following main conclusions can be drawn from the above data:

- Over-capacities of aluminium smelters and alumina plants seem to be lasting ones. This is one of the reasons why free market prices do not cover even the production costs at many producers.
- The structure of production costs suffered a substantial change in the past 20 years. The proportion of energy costs increased in 1975 compared to 1965, while the capital cost charges reached nearly half of the total costs in newly established plants by today.
- The increase of capital costs per unit capacity was considerably more rapid than the inflation rate, but this can not be explained by the change of material prices, of construction costs, nor by the modified technical content.
- Plants under construction are preferably located together with smelters in places where abundant raw material deposits and cheap energy sources are simultaneously present.
- There is a keen competition for the exploitation of existing capacities, keeping these alive. Bauxite producers are compelled to mine their best quality bauxites to satisfy actual market demands which become more and more demanding. In case of existing plants those having lower variable costs reach a favourable position step by step, which results in the geographical rearrangement of production.

- Decisions to establish new capacities can only be expected after the reasonable utilization of existing ones. However, in order to reduce capital cost charges, the reconstruction or expansion of existing plants will have preference compared to green field establishments.

The above conclusions concerning the aluminium and alumina industries are well reflected in the area of development efforts as well. It can be stated in general that the reduction of energy consumption was in the center of technical progress during the past decade, while the main moving force of today's development efforts is to increase capital efficiency due to the rapid increase of capital expenses.

Increasing energy costs drew the attention to the efficiency of the process cycle and the aluminate liquor productivity in the past decade. It can be seen from the data shown, that the increase of investment good prices is similar to the oil price boom. This fact has put the increase of capital productivity in the limelight. This means that besides or instead of looking for optimum energy consumption, the optimum of capital productivity should be strived for. In the forthcoming considerations this aspect shall prevail.

The Scientific Committee of the Symposium "Alumina Production until 2000" stated as main trends of development of the Bayer technology the following: to develop an energy saving technology; to increase the role of high temperature digestion; to introduce high capacity equipment, a fully automated process and a computerized control system.

The main plant units of the Bayer process are digestion and precipitation. Let us survey these two basic units from the point of view of liquor cycle and plant productivity.

### Optimum conditions of precipitation.

It could be said, that the main line of development consists of those efforts, which assure besides the high liquor yields of the European Bayer process (70-80 g/dm<sup>3</sup>) the properties of American Bayer products. As a matter of fact in the latter case the liquor yield is only 40-50 g/dm<sup>3</sup>, but precipitation holding times are much shorter, only 30-50 hours versus 50-90 hours of the European process. Several reviews have been published in this field (e.g. [5, 6, 7]).

Possibilities are, however, not exhausted by far. Further efforts are necessary to combine the increase of high precipitation yields with the required alumina quality. Trends of development are:

- increase of Na<sub>2</sub>O<sub>k</sub> concentration
- modification of the precipitation technology.

In the course of precipitation the Al<sub>2</sub>O<sub>3</sub> content of the aluminate liquor changes continuously. In our previous publication [8] it was established that a certain temperature belongs to every Na<sub>2</sub>O<sub>k</sub> concentration and molar ratio, where the rate of precipitation is the highest. The temperature regime belonging to the highest rate can be determined here with (see Fig.6) and by implementing the same, very favourable molar ratios can be attained in synthetic aluminate liquors at various precipitation times as shown in Fig.7.

It has to be emphasized that such temperature regimes show an optimum for precipitation yields only. An optimum considering also the required grain size and properties can be a different one [9]. A similar conclusion was drawn by

Ljapunov and Davidov in respect of the optimum temperature regime in their paper of 1983 [10].

The results in plant liquors are, however, far less favourable than in synthetic ones due to the liquor impurities. There are several publications dealing with the influence of various impurities on the precipitation rate [11, 12, 13]. It can be stated in general, that the effect of inorganic impurities on the precipitation rate is similar to that of the increase of the caustic  $\text{Na}_2\text{O}$  concentration, although its extent is much less, approx. 50 %.

Liquor impurities should be removed to increase the precipitation yield. Several processes exist for this aim. The liquor causticization with burnt lime in the course of red mud washing is the most obvious solution for the regeneration of caustic  $\text{Na}_2\text{O}$  from carbonate salts. The amount of regenerable caustic is, however, limited in this process step because of the formation of  $3\text{CaO}\cdot\text{Al}_2\text{O}_3$ , therefore an additional carbonate salt removal is also usually required by means of a high concentration evaporation of the liquor (in a so-called crystallizing evaporator). Examining the different possibilities and ratios of soda salt removal it can be stated that the European Bayer process allows an 8-12 % carbonate level in practice [14, 15]. It would be of interest to investigate the possibilities of reducing the carbonate content of the American Bayer liquors as one of the most promising ways of increasing its efficiency. The removal of V, P and F salts can also take place from the spent liquor [16].

Investigating organic impurities we found that the humic acids reduce the precipitation yield and cause finer grain sizes in every case. Others came to the same results. The effect and removal of organics has been investigated by several researchers [17, 18, 19]. Oxalate can be removed

from the precipitated liquor and/or the hydrate wash water, whilst the removal of other organics can be solved either by various additives (like barium aluminate, magnesium hydroxide, some organic additives, etc.) or by liquor ignition, further by calcining the carbonate salts precipitated by superconcentrating the liquor in evaporators. Our latest results show that the so-called wet oxydation of the liquor at temperatures above 200 °C gives also favourable results [20].

The precipitation technology has developed substantially in the past years in order to combine the conditions of good precipitation yields with the required physical properties of the alumina. For this aim the agglomeration technics, the multistage seeding and the necessary classification of the hydrate grains and last but not least cooling to assure the required temperature regime were introduced. Today's batch and continuous precipitation technologies are the combination of these elements adjusted to local conditions as shown in Fig.8.

#### Developments in digestion

The effect of the specific volume of digestion liquor on the liquor efficiency is well known. Development of this operation is first of all related to monohydrate bauxite processing. The trend of increasing digestion temperature is determinant. The optimum temperature is nowadays usually in the range of 240-250 °C in autoclaves and 260-280 °C in tube digesters. Besides the great intensity of digestion (short retention time, low molar ratio, a yield near to theoretical) the energy consumption is also considerably reduced, furthermore great advantages originate from improving the red mud properties (settling, high density com-



pression zone, filtrability). As a result of these the  $\text{Fe}_2\text{O}_3$  content of the pregnant liquor has decreased to 10-30 mg/l without control filtration in one of the Hungarian plants. Besides the substantial increase in capacity the amounts of  $\text{Na}_2\text{O}$  and  $\text{Al}_2\text{O}_3$  attached to the red mud have decreased by 50 % at the same time.

The Hungarian version of the tube digester (Fig.9), which includes the possibility of further temperature increase, is a multiple stream (3 tube) system and is characterized by the cyclical change of the slurry and digestion liquor streams in the tubes assuring thus the dissolution of the scales formed during operation. The streams are united at the final temperature of digestion and in this way the total volume of the digestion liquor works for the dissolution of the aluminium containing minerals.

The development of digestion technology brings results mainly in such plants, where the increase of digestion temperature is limited or can only be achieved by means of huge investments. The hydrothermal transformation of goethite to hematite can be realized at digestion temperatures of 220-250 °C by various additives (e.g. iron hydrogarnets) [22, 23, 24]. The main advantages of these processes versus the conventional ones using only burnt lime are the following:

The goethite-to-hematite transformation can be realized safely even in the case of bauxites with very stable goethite contents (e.g. Guinean bauxites).

The minimum temperature required for the transformation can be reduced by 20-30 °C, the retention time by 40-70 % and the burnt lime consumption by 20-30 %.

The chemical  $\text{Na}_2\text{O}$  losses can also be reduced similarly to the causticization of red mud, but in this case a lower

specific CaO consumption can be achieved, because the Fe<sup>3+</sup> ions are built into the hydrogarnet structure and consequently the SiO<sub>2</sub> content of the latter gets higher and its Al<sub>2</sub>O<sub>3</sub> content lower (Figs.10, 11).

The reduction of the specific amount of water to be evaporated is important from the point of view of both the energy consumption and the efficacy of the process cycle. This can be achieved by reducing the amount of water used for washing the red mud and the product hydrate, by avoiding miscellaneous dilutions (parasite waters) and by flash cooling the hot slurries and liquors. Over and above the known developments in equipment (filters instead of settlers, reconstruction of the settlers themselves, etc.) substantial results can be achieved by up to date flocculants, the use of which is at the same time more favourable from the point of view of accumulation of organics than that of the formerly used starch or flour [25].

The modernization of settling and red mud washing also results in the diminishing of attached caustic and alumina losses. In case of bauxites with higher SiO<sub>2</sub> contents the chemical Na<sub>2</sub>O losses cause also large expenses. Reduction of these expenses justify beside the mentioned technology using additives (hydrogarnet) even the causticization of the red mud, whereby 50-60 % of the chemical Na<sub>2</sub>O losses can be recovered at 95-100 °C by adding 3 mol CaO per mol Na<sub>2</sub>O.

According to our newest results in a so called complex causticization process [15] the causticization of the carbonate content of the liquor, of the removed carbonate salt and that of the red mud is united into a single process. This process can be adjusted for a relatively small investment to the existing Bayer process.

To extend the limits of the Bayer process for processing medium and low grade bauxites (with high  $\text{SiO}_2$  contents) it is possible to treat the red mud hydrothermally at a temperature of  $300^\circ\text{C}$  resulting in hydrogarnet formation. Using a caustic liquor with a molar ratio of 4.5 90-95 % of the  $\text{Na}_2\text{O}$  content and 20-25 % of the  $\text{Al}_2\text{O}_3$  content can be recovered in a self-supporting process with a specific lime consumption as low as 2.5 kg  $\text{CaO}$  per kg regenerated  $\text{Na}_2\text{O}_k$ . The technical preconditions of the industrial realization of this process can be met by further developing the tube digestion.

Summing up it can be stated that one can not count with the significant change of the present situation in the aluminium industry and within the same in the alumina industry of the world in the near future. Excess capacities, depressed prices and the geographical rearrangement of this industry towards areas assuring more favourable production costs will stay characteristic.

The promoter of technical improvement will be more and more the better exploitation of capital goods, the increase of the efficiency of the plant. The technological possibilities, including the equipment suitable for these and the main trends of development are summarized on the basis of the abovementioned in Table 1. The importance of increasing the digestion temperature, of purifying the process liquors and of increasing the precipitation concentration is to be repeatedly emphasized.

Table 1.

## MAIN TASKS OF THE TECHNICAL IMPROVEMENTS OF ALUMINA PRODUCTION

Main directions of R + D	Targets	Possible solutions
1. Improvement of efficacy of precipitation by increasing the $\text{Na}_2\text{O}_k$ concentration of the liquor	To reach good performance in precipitation while securing requested alumina qualities	Purification of solution <ul style="list-style-type: none"> <li>- removal of carbonate salts and regeneration of their <math>\text{Na}_2\text{O}</math> contents by               <ul style="list-style-type: none"> <li>. crystallizing evaporation</li> <li>. causticization in the washing line</li> <li>. complex causticization</li> </ul> </li> <li>- removal of organics by               <ul style="list-style-type: none"> <li>. feeding magnesium salts</li> <li>. evaporation of hydrate wash water, oxalate separation</li> <li>. liquor and/or salt ignition</li> <li>. wet oxidation</li> </ul> </li> </ul> Development of technology <ul style="list-style-type: none"> <li>. agglomeration</li> <li>. hydrate classification</li> <li>. multistage seeding</li> <li>. cooling during precipitation</li> </ul>
2. Increasing the digestion temperature at the processing of monohydrate bauxites	To improve kinetics, to reach the theoretical yield, to conserve energy, to obtain well handable red mud	In autoclaves at 240-250 °C  in tube digester at 260-280 °C

Table 1. (cont.)

Main directions of R + D	Targets	Possible solutions
3. Increasing efficacy of existing digestion lines	To release the limitations of the equipment by increasing the temperature and by modifying the technology	Technology using additives
4. Energo-technology, increase of capital productivity, optimization of the process	To minimize production costs, to increase plant productivity	Coordination of digestion and precipitation parameters and of the quantity of water to be evaporated
5. Reduction of caustic consumption	To reduce chemical and attached losses	<ul style="list-style-type: none"> <li>- Carbonate salt causticization</li> <li>- Red mud causticization</li> <li>- Complex causticization</li> <li>- Hydrothermal (high temperature) treatment of red mud (in case of medium and poor quality bauxites).</li> <li>- Modernization of red mud washing               <ul style="list-style-type: none"> <li>. modification of settlers</li> <li>. heavy-duty filters</li> <li>. up to date flocculants</li> </ul> </li> </ul>

## REFERENCES

- [1] Castera, M.: Movements in Vertical Integration within the Aluminium Industry. Metal Bulletin's Second International Aluminium Congress, Monte Carlo, 1982.
- [2] Davis, C.E.: Market Trends in Bauxite and Alumina. IBA Review October-December 1984. pp. 7-16.
- [3] Perry, K.W. and Russel, A.S.: Advances and Prospects in Alumina technology. Journal of Metals Oct. 1982. pp. 48-53.
- [4] Bielfelds, K. Winkhaus, G.: Challenge to Alumina Production Technology in the 80's. Alumina Production untill 2000. Proc. of Int. Symp. of ICSOBA, 1981. pp. 111-120.
- [5] Tschamper, O.: Improvements by the New Alusuisse Process for Producing Coarse Aluminium Hydrate in the Bayer Process. Proc. of the 110th AIME Ann Meeting Chicago, 1981. Light Metals, 1981. pp. 103-115.
- [6] Kirke, E.A.: Recent Trends in Bayer Precipitation Practice. Chemical Engineering in Australia, Vol ChE7, No 1, March 1982. pp. 35-39.
- [7] Anjier, L. J. and Roberson, M.L.: Precipitation Technology. Proc. of the 114th AIME Ann. Meeting New York, 1985. Light Metals, 1985.

- [8] Solymár, K., Zámbo, J.: Über die optimalen Verhältnisse der Präzipitation der Aluminatlaugen. Proc. of the third European Symp. on Chemical Reaction Engineering, Amsterdam, 15-17 Sept. 1964. Pergamon Press. Oxford, London, New York, Paris.
- [9] Scott, J.: Effect of Seed and Temperature on the Particle Size of Bayer Hydrate Extractive Metallurgy of Aluminium. Volume 1. Alumina. Proc. of AIME Symposium, New York, 1962. pp. 202-218.
- [10] Ljapunov, A.N. and Davidov, I.V.: Optimization of Temperature Conditions of the Aluminate Liquor Decomposition Process. Cvetnie Metalli 1983. No. 1. pp. 44-46. (in Russian)
- [11] Bird, R.D., Vance, H.R., Fuhram, C.: The Effect of four Common Bayer Liquor Impurities on Alumina Solubility. Proc. of 112th AIME Ann. Meeting. Atlanta, 1983. pp. 65-82.
- [12] Lectard, A. and Nicolas, F.: Influence of Mineral and Organic Impurities on the Alumina Trihydrate Precipitation Yield in the Bayer Process. Proc. of 112th AIME Ann. Meeting. Atlanta, 1983. pp. 123-142.
- [13] Bibik, I.D., Dzorobekova, S. Dr.Nassirov, N.Z.: Influence of Organic Materials on Decomposition of Aluminate Liquor. Cvetnie Metalli 1984. No.9. pp. 43-46. (in Russian)

- [14] Baksa, Gy., Valló, F., Kalocsai, F., Vitéz, J.:  
Cycle Cleaning Possibilities in Bayer Alumina  
Processes. TRAVAUX, ICSOBA, vol. 12., No.17. Zagreb,  
1982. pp. 97-116.
- [15] Baksa, Gy., Valló, F., Zöldi, J., Solymár, K.: Complex  
Causticization Efficient Means for Reducing NaOH  
Losses in the Alumina Production. The paper announced  
on the 115th AIME Annual Meeting.
- [16] Tóth, B., Vörös, I., Zambó, J.: Situation and Develop-  
ment of the Hungarian Alumina Industry Alumina Produc-  
tion until 2000. Proc. of ICSOBA Symposium. Tihany,  
Hungary, 1981. pp. 271-282.
- [17] Deabriges, J., Noble, M., Magrone, R.: Purification  
of Bayer Liquors by Barium Salts. Proc. of 106th AIME  
Annual Meeting. Atlanta, 1977. Light Metals 1977.  
p. 15.
- [18] Gnyra, B. and Lever, G.: Review of Bayer organics.  
Oxalate Control Processes. Proc. of 108th AIME Ann.  
Meeting, New Orleans, 1979. Light Metals, 1979. p. 151.
- [19] Yamada, K., Harato, T. and Kato, H.: Oxidation of  
Organic Substances in the Bayer Process. Proc. of  
110th AIME Ann. Meeting. Chicago, 1981. Light Metals,  
1981. pp. 117-128.
- [20] Mátyási, J., Siklósi, P., Ziegenbalg, S.: Liquor  
Purification Wet air oxidation. Paper on the 114th  
AIME Ann. Meeting. New York, 1985.



- [21] Solymár, K., Ferenczi, T. and Zöldi, J.: The Effects of Technology on the Properties of Red mud. TRAVAUX de l' ICSOBA, 1979. No.15. pp. 287-305.
- [22] Solymár, K., Steiner, J.: Energy and Technological Advantages of Tube Digestion and Digestion with Additives. J. Geol. Soc. of Jamaica. Proc. of Bauxite Symp. No. V., 1982. pp. 223-232.
- [23] Solymár, K., Zámbo, J., Siklósi, P.: Technological Evaluation of Monohydrate Bauxites. Bauxite. Proc. of the 1984. Bauxite Symp. Los Angeles, 1984. pp. 727-746.
- [24] US Patents Nos: 4,026.989; 3,944.648; 4,091.071 and 4,226.838.
- [25] Pearse, M.J. and Sartowski, Z.: Application of Special Chemicals (Flocculants and Dewatering Aids) for Red Mud Separation and Hydrate Filtration. Bauxite. Proc. of the 1984. Bauxite Symp. Los Angeles, 1984. pp. 788-810.

Fig. 1

### ALUMINIUM CAPACITIES, PRODUCTION AND CONSUMPTION

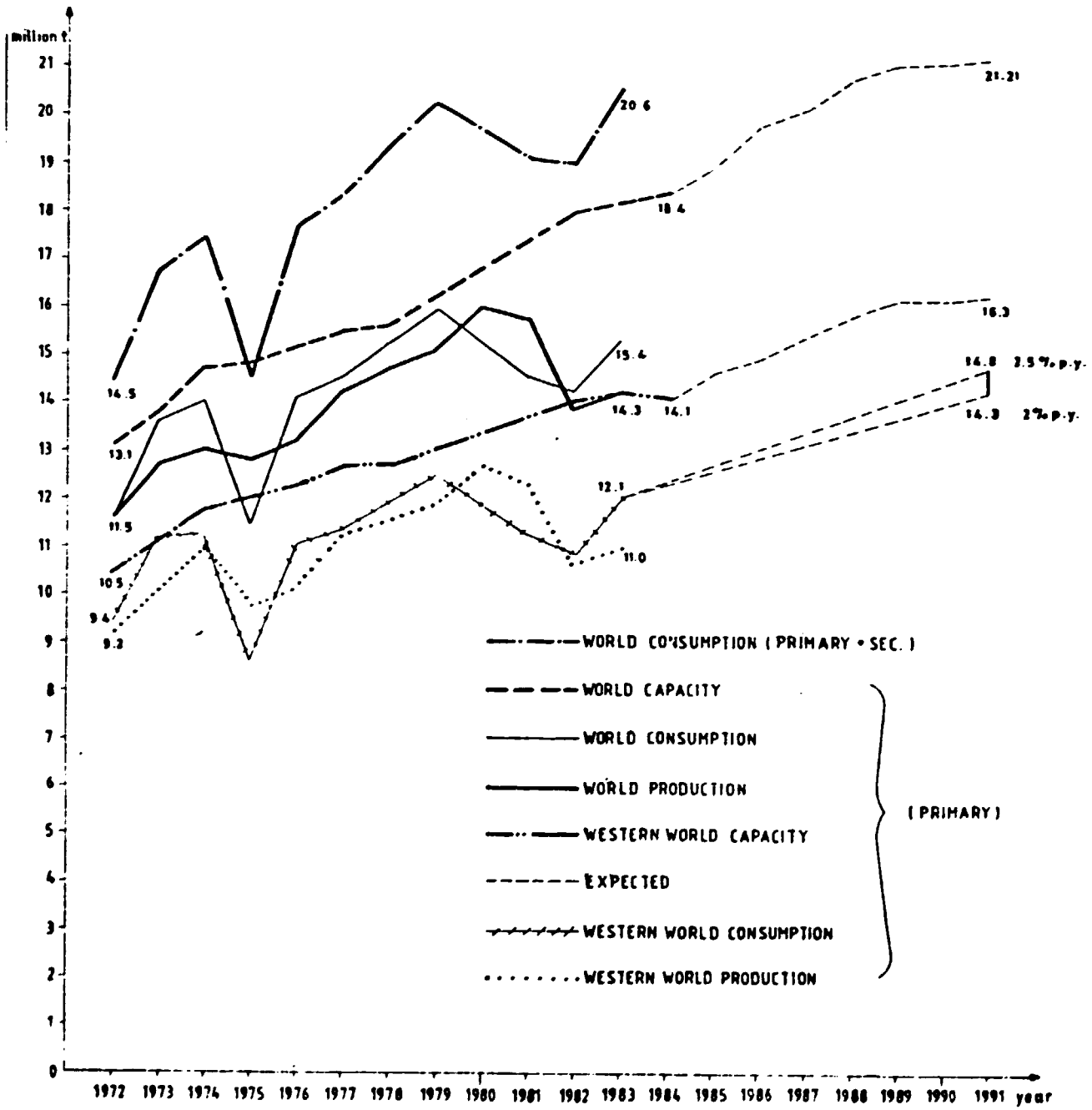

# ALUMINA CAPACITIES AND PRODUCTION

Fig. 2

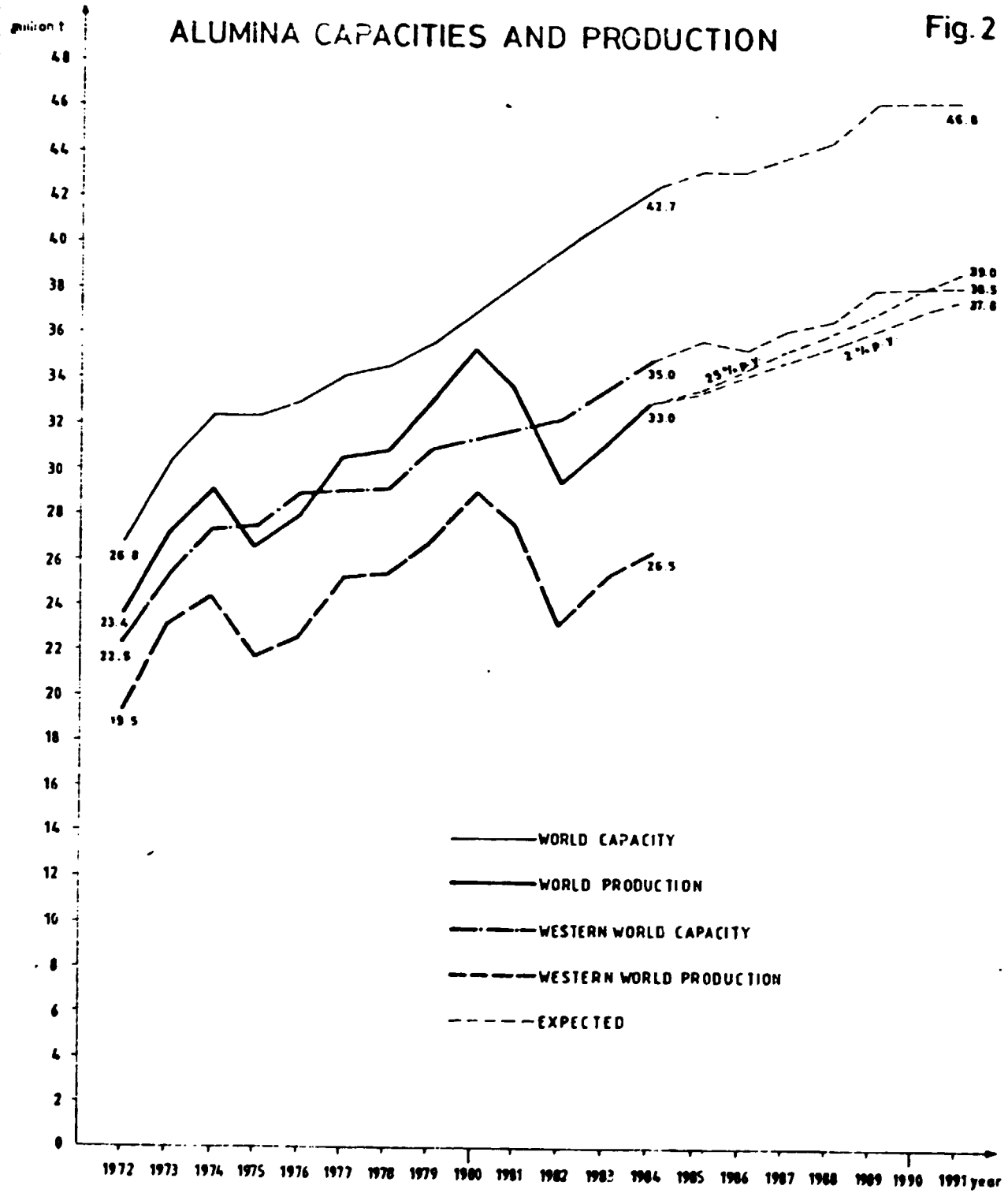

## CHANGE IN PERCENTAGE DISTRIBUTION OF PRODUCTION COSTS FOR ALUMINA PLANTS

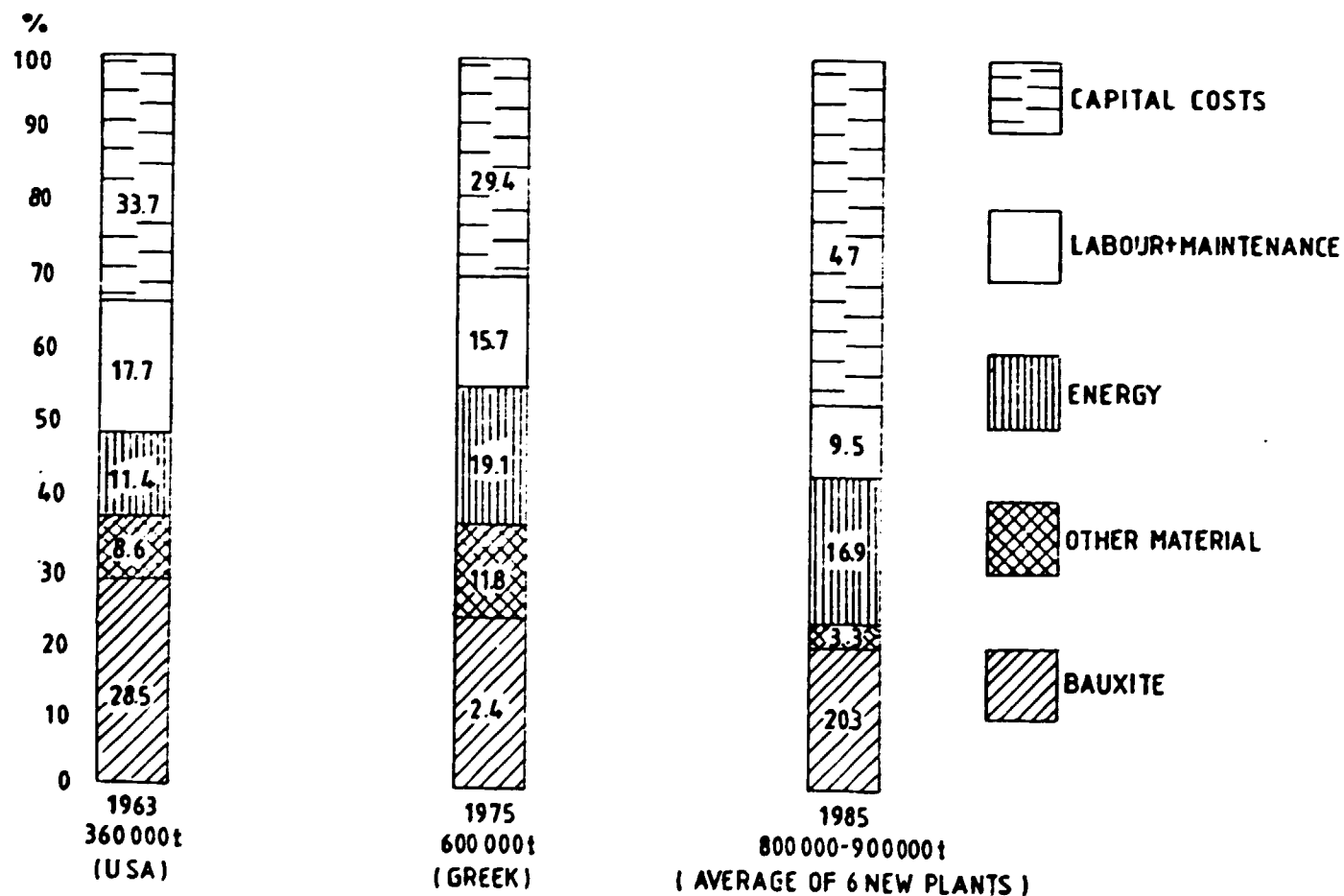

# CHANGE IN PRODUCTION COSTS OF ALUMINA VERSUS BAUXITE AND ALUMINA PRICES

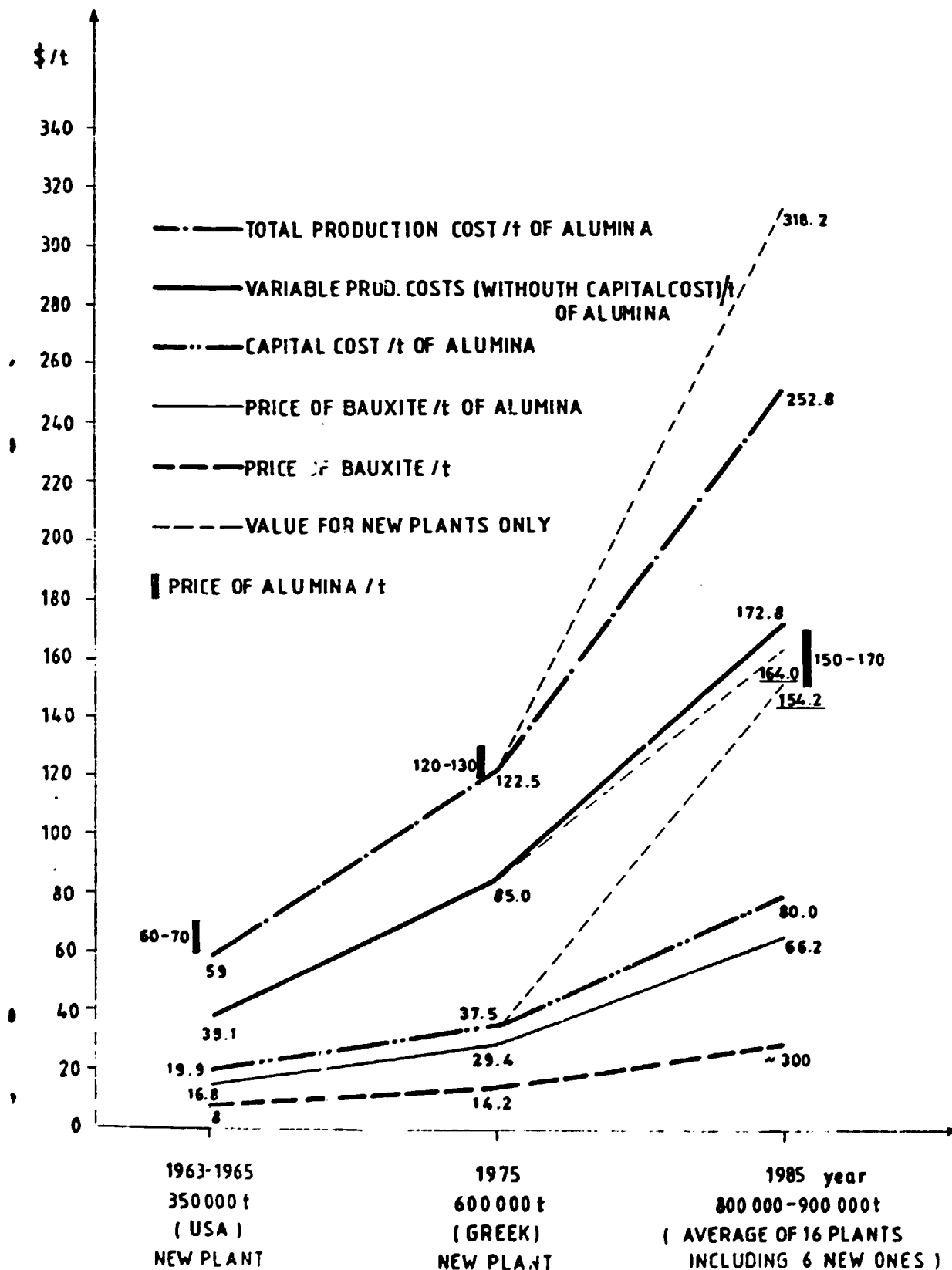

# ALUMINA AND FUEL PRICES, INVESTMENT COSTS OF ALUMINA PLANTS AND INVESTMENT INDICES

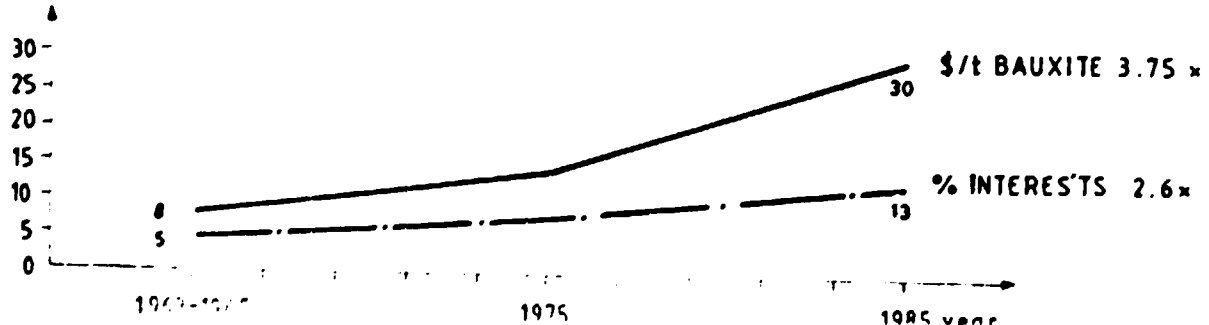
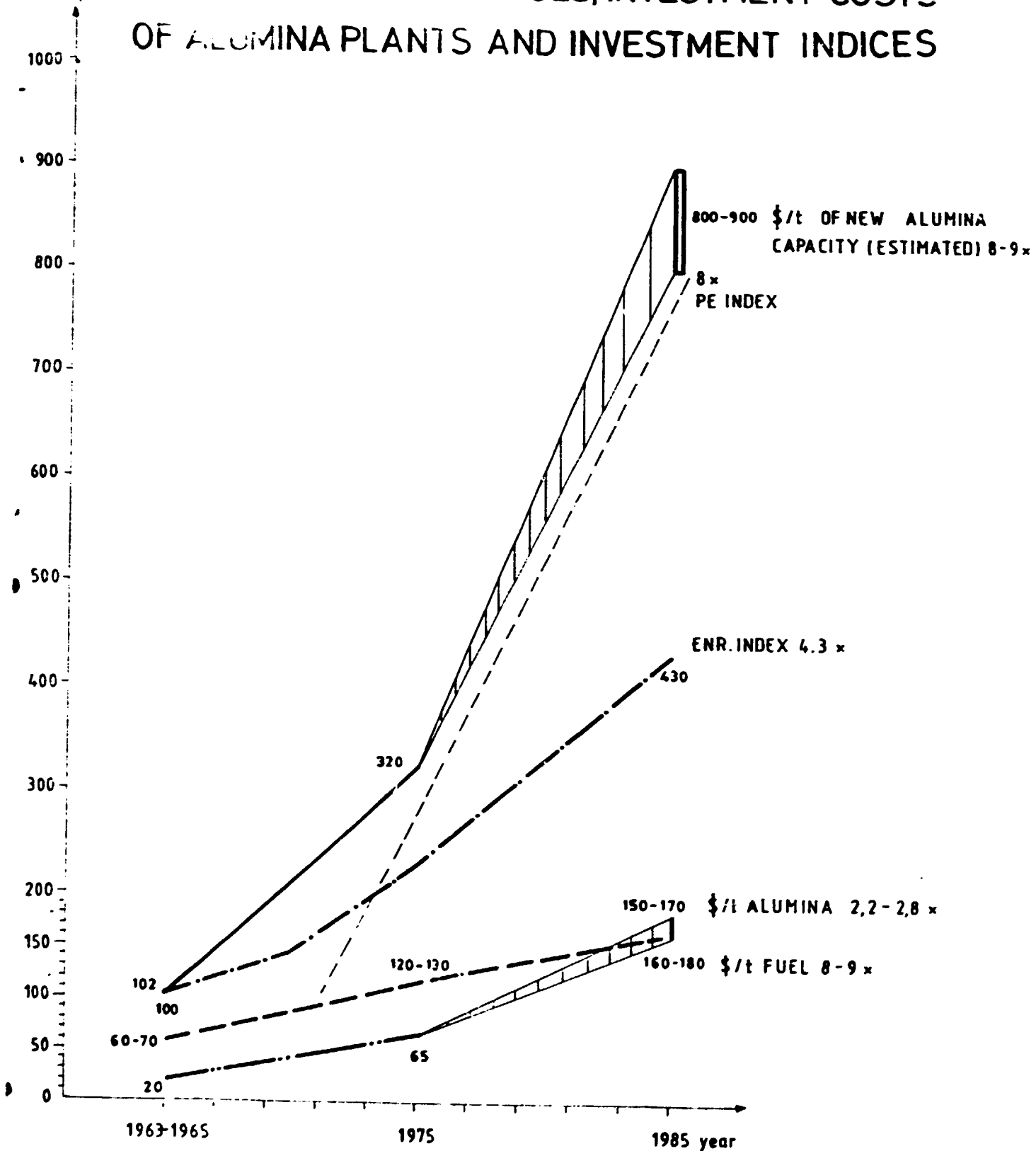
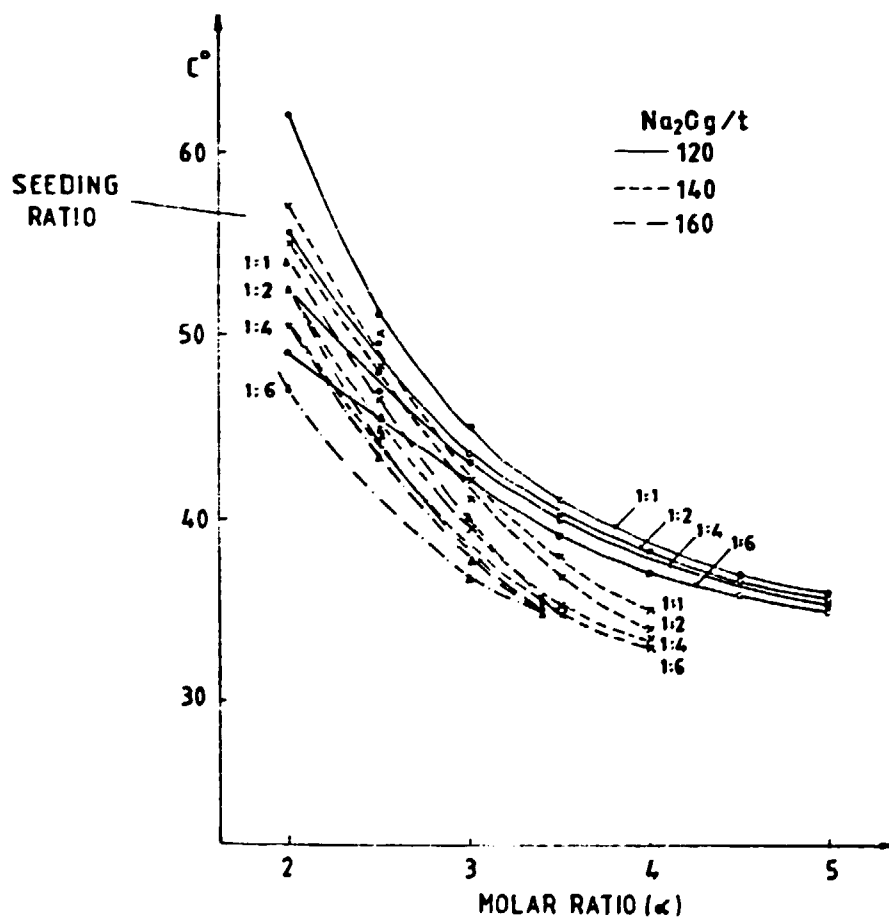
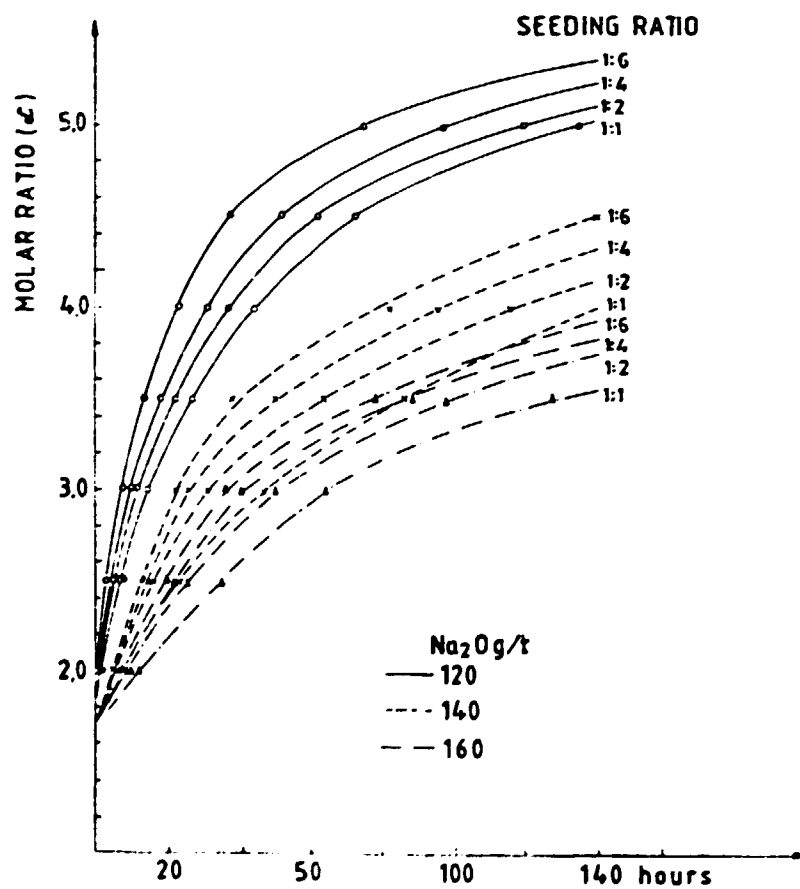

Fig. 6

# TEMPERATURE CONDITIONS FOR MAXIMUM PRECIPITATION YIELD



## PRECIPITATION MOLAR RATIO AT OPTIMAL TEMPERATURE CONDITIONS





# PRECIPITATION SYSTEMS USING AGGLOMERATION

## SINGLE LINE PRECIPITATION SYSTEMS

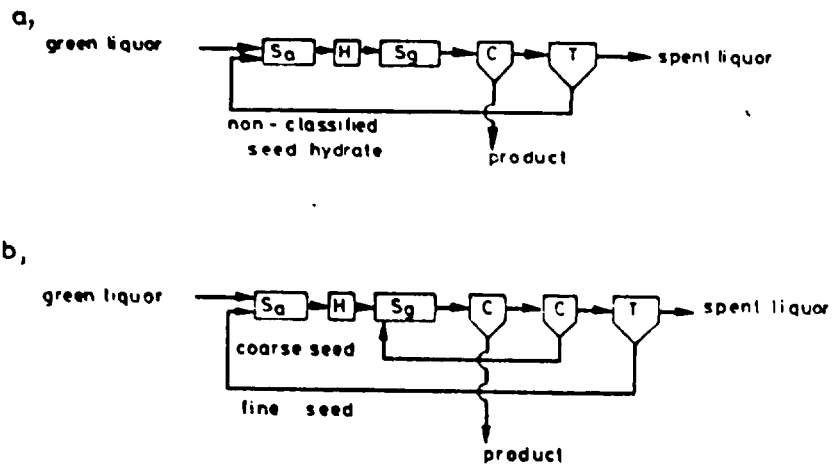

## TRIPLE LINE PRECIPITATION SYSTEM /KAISER/

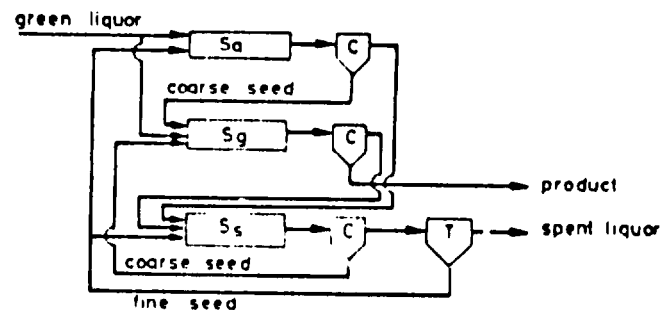

## DOUBLE LINE PRECIPITATION SYSTEMS

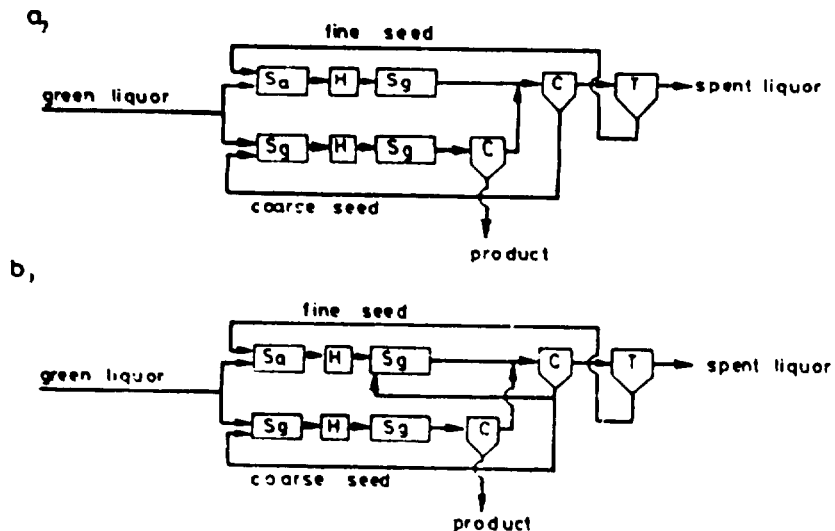

## PRECIPITATION SYSTEM USING CRYSTAL GROWTH

(PECHNEY PROCESS)

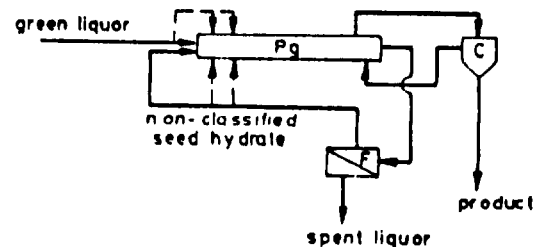

NOTE: Sa agglomeration section  
Sg crystal growth section  
Ss seed generation section  
Pg crystal growth precipitation  
H heat interchange  
C classifier  
T thickener  
F filter

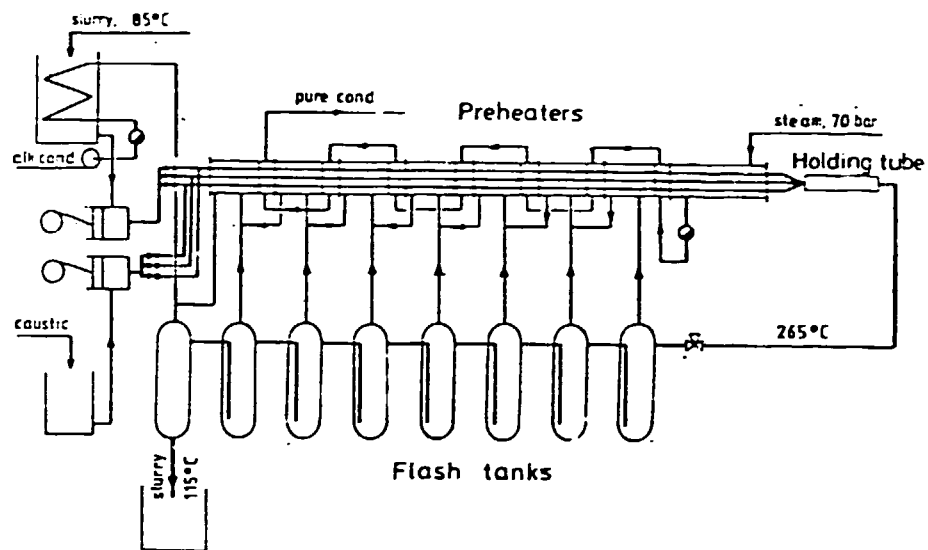

Figure 9 | Tube digestion system

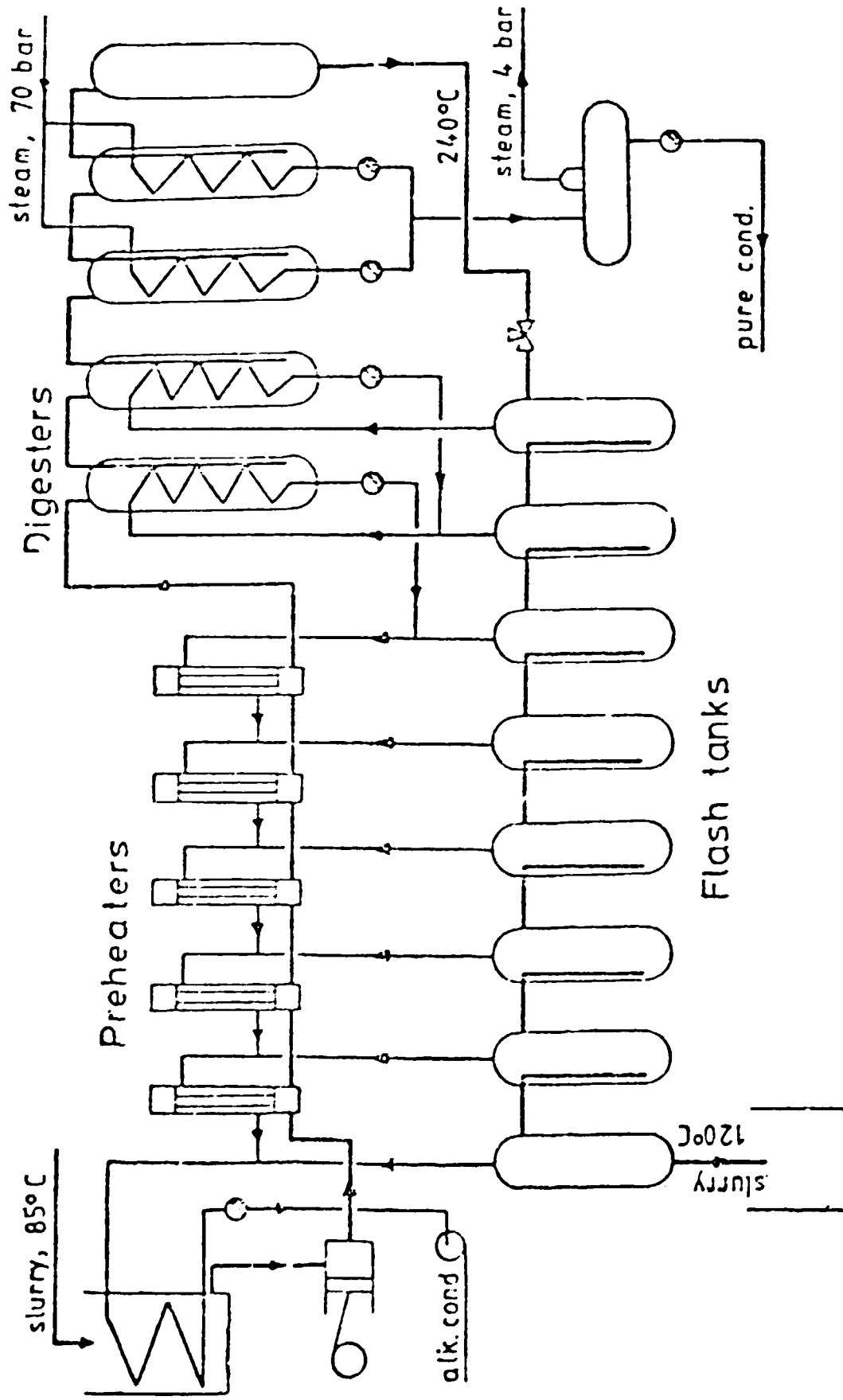
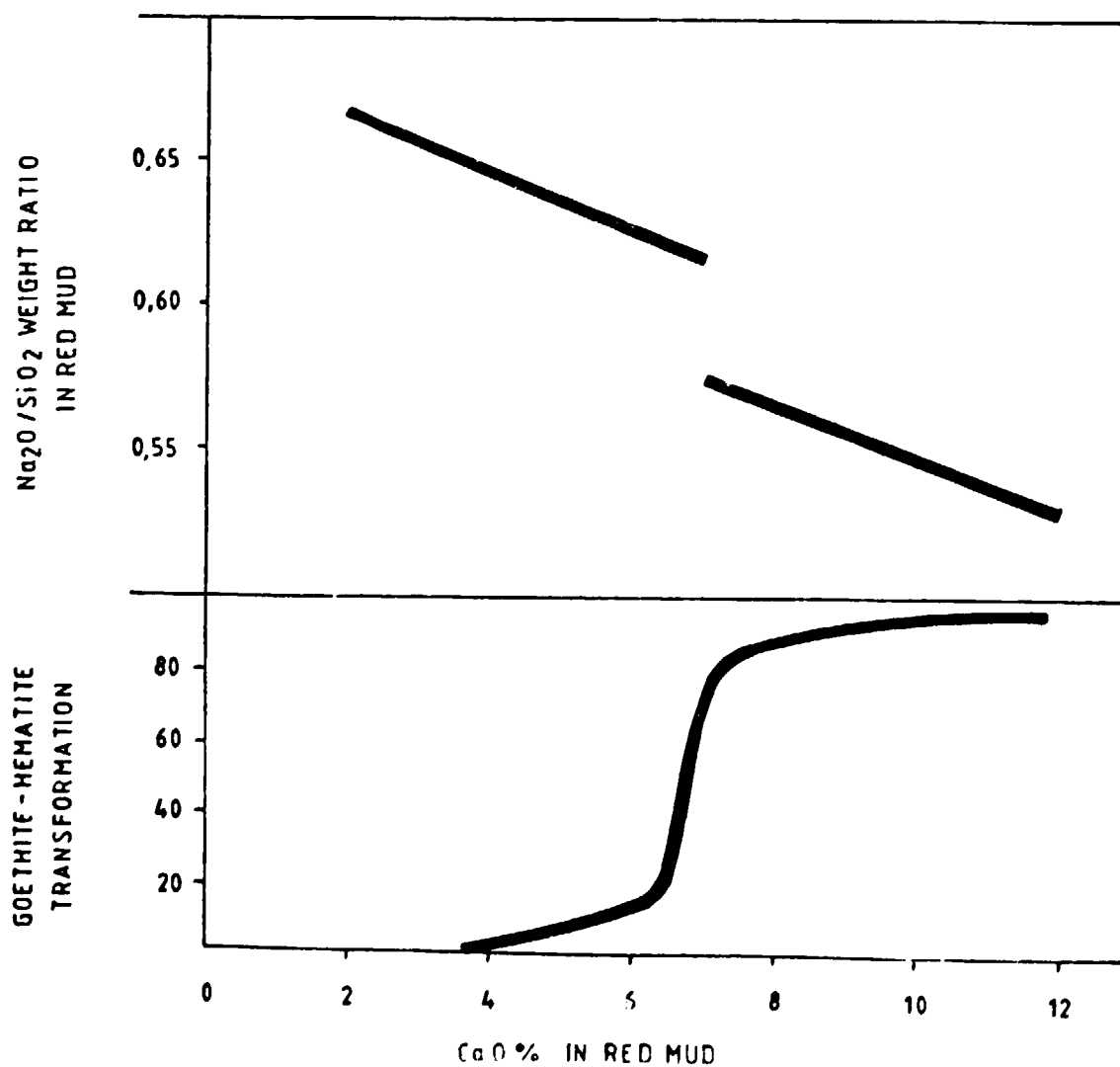

Fig. 9. Digestion line

## INFLUENCE OF GOETHITE-HEMATITE TRANSFORMATION ON BOUND CHEMICAL Na<sub>2</sub>O LOSSES AT AJKA PLANT



# SAVINGS OF NaOH AND IMPROVEMENT IN YIELD BY GOETHITE - HEMATITE TRANSFORMATION AT ALMÁSFÜZITŐ PLANT

