



TOGETHER
for a sustainable future

OCCASION

This publication has been made available to the public on the occasion of the 50th anniversary of the United Nations Industrial Development Organisation.



TOGETHER
for a sustainable future

DISCLAIMER

This document has been produced without formal United Nations editing. The designations employed and the presentation of the material in this document do not imply the expression of any opinion whatsoever on the part of the Secretariat of the United Nations Industrial Development Organization (UNIDO) concerning the legal status of any country, territory, city or area or of its authorities, or concerning the delimitation of its frontiers or boundaries, or its economic system or degree of development. Designations such as “developed”, “industrialized” and “developing” are intended for statistical convenience and do not necessarily express a judgment about the stage reached by a particular country or area in the development process. Mention of firm names or commercial products does not constitute an endorsement by UNIDO.

FAIR USE POLICY

Any part of this publication may be quoted and referenced for educational and research purposes without additional permission from UNIDO. However, those who make use of quoting and referencing this publication are requested to follow the Fair Use Policy of giving due credit to UNIDO.

CONTACT

Please contact publications@unido.org for further information concerning UNIDO publications.

For more information about UNIDO, please visit us at www.unido.org

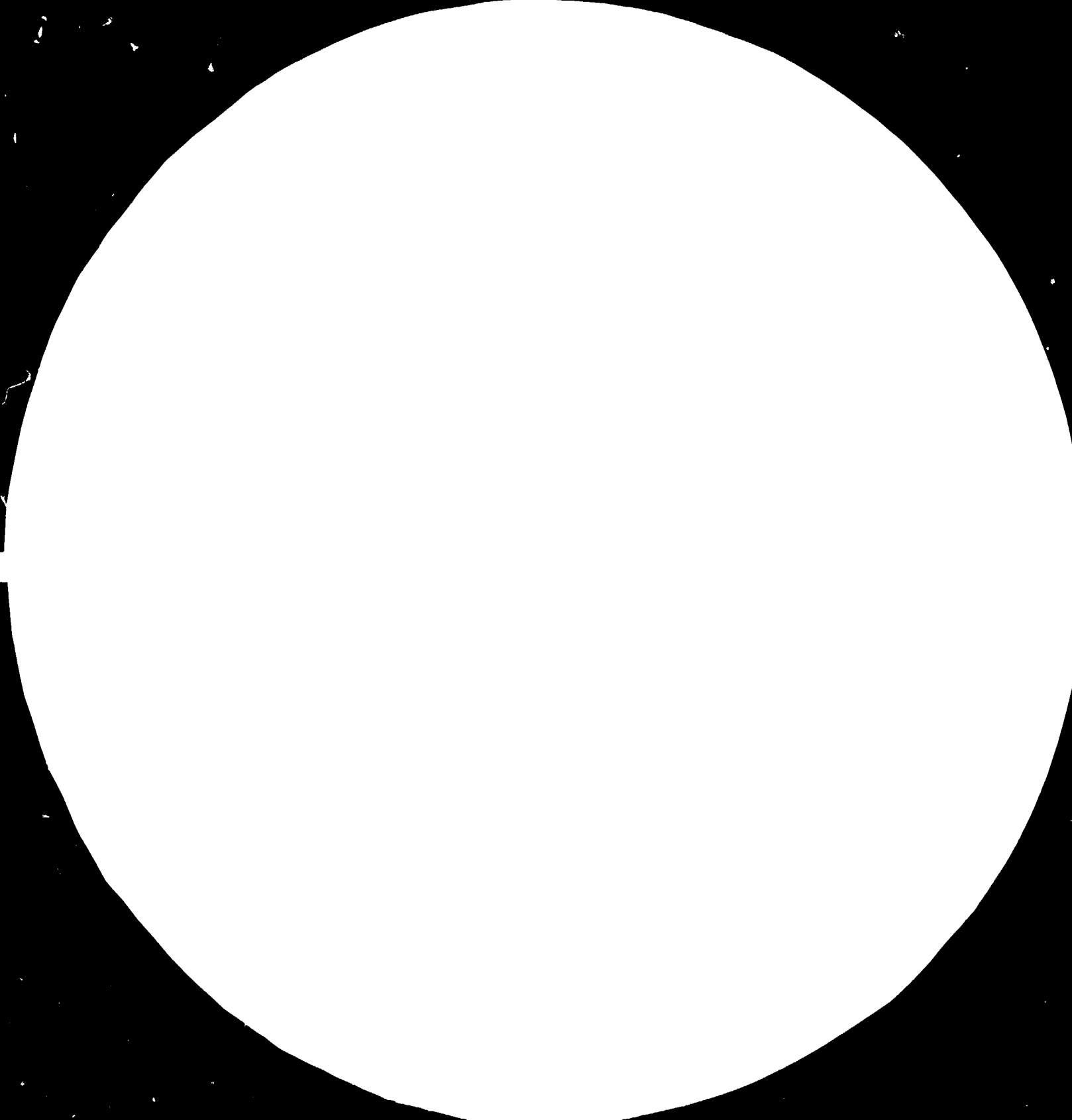

MICROCOPY RESOLUTION TEST CHART
 NATIONAL BUREAU OF STANDARDS-1963-A
 U.S. GOVERNMENT PRINTING OFFICE: 1963 O 338603

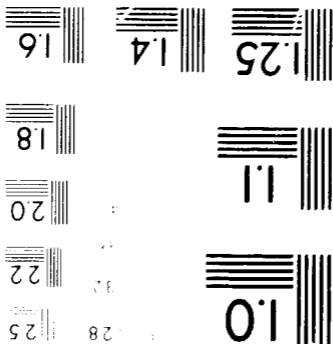

14238

Egypt.

REPORT ON MOBILE TRAINING UNITS FOR EIDDC

INDUSTRIAL TRAINING ADVISORY SERVICES, TO THE
ENGINEERING AND INDUSTRIAL DESIGN AND DEVELOPMENT
CENTRE, CAIRO

DP/EGY/81/011

Prepared by Shirley A. Parfitt, A/V Expert
UNIDO/UNDP/EGY/81/011/11-02/31.5A

December 1983

1.

MOBILE TRAINING UNITS

Five options are described below. However, each manufacturer is very flexible and numerous variations can be supplied to the client's individual requirements.

These options are presented as possible examples as a basis for decision-making.

1. Mobile video unit kit

This is a box which can be placed in a Landrover, Ford Transit or similar vehicle, where it is ready for immediate viewing by outdoor audiences, or it can be carried indoors.

It contains a specially tough video monitor, V.C.R. and independent power supply. Two variations are described.

Supplier : Argivisual. Cost version A (standard) £ 6,750
version B (automatic) £ 7,350

2. Mobile Training Unit

This is a specially fitted-out Landrover, or other vehicle, suitable for making a/v presentations to outdoor audiences. Generator is supplied for power requirements.

Supplier : Agrivisual . £ -21,585

: British Films £ 17,950 approx.

3. Mobile Training British Films Ltd. plus Video production Unit

This is also a specially fitted out vehicle suitable for making a/v presentations to outdoor audiences, plus full u-format video shooting, editing and telecine equipment. This version facilitates the use of video as a recorder of local conditions / craftsman skills, and also to make training films "on the-spot" to local requirements. Power take-off unit for power requirements.

Supplier : British Films. Cost £ 27,950 with video equipment
approx £ 17,950 without video equipment

4.a) Mobile classroom plus video production studio

This version is a 40' long trailer plus traction unit, fitted out as a 25 seater cinema and lecture unit, plus full video shooting, editing, playback & telecine facilities.

Supplier : British Films Ltd.

Price : £ 64,950 complete.

b) Mobile classroom

As above but without the video production facilities.

Price : £ 54,950

1. MOBILE VIDEO UNIT KIT

SECURITY

The controls, the V.C.P. and all electronics are accessible quickly but all access bolts are tamper proof or a key lock is fitted. The video cassette is accessible only to a key holder. The system is therefore safe in the hands of an unskilled operator.

The Monitors P.C.B. is mounted remotely on a sub-rack.

A National Panasonic 8170 or JVC 5300 playback only V.C.P. (both VHS) is mounted behind locked doors that contain the loud speaker (Most V.C.P. and V.C.R. can be accommodated)

SYSTEM RELIABILITY

Previously the major obstacle to the use of video equipment in mobiles has been the problem of shock and vibration.

Designed for Landrovers and all similar vehicles, this video system is intended for use in the roughest of conditions.

"Previously trials in Nigeria in conditions of 44°C... and high humidity on unmade dirt roads have shown very high system reliability" (Agin Visual)

The video equipment is robust. (The BARCO 26" Monitor has its T.V. tube mounted via rubber bushing direct to the light alloy inner cabinet.

In transit the complete system is suspension mounted.

Power

a) Supply

240 V, 500 watt square wave inverter from second storage battery. An uprated alternator for the vehicle is supplied with the Video kit. Battery and charging capacity has proved to be more than adequate for two hours viewing between charges and in normal usage no external power is required.

b) Safety

Should there ever be a potentially dangerous short circuit an E.L.C.B. (earth leakage circuit breaker) will trip and an alarm will sound. Whenever this system is running or when external power is connected, the vehicle is immobilised by a plug in module which isolates the starter solenoid.

FURTHER FACILITIES

L.E.D. indications for "low power", "charging" and "charged", "overheat", "rewinding".

Battery charger suitable for zero maintenance or conventional batteries.

Power change over for internal or external mains, cycle time recorder.

TOOLS

All tools required for a normal workshop to fit the above units to existing vehicles are included in the price.

PRICE

STANDARD VERSION

£ 6,750.00 FOB U.K. Port

AUTOMATIC VERSION

£ 7,350.00 FOB U.K. Port

Delivery eight-ten weeks

September '83

MOBILE VIDEO UNIT

SVC through Bell & Howell

A new Mobile Video Unit developed by Agri-Visual of Wokingham.

- * Video Presentation
- * Public Address Kit and Audio Cassette Player
- * Self-powered, independent of external source
- * Shock and vibration resistant
- * Tamper-proof design
- * Fits wide range of vehicles
- * Fully interlock controls via programmed tape of simple three button control
- * High reliability in hot and rough tropical conditions
- * Easy servicing with exchange circuit panels
- * Capable of quick fitting to wide range of vehicles
- * Easy to operate by unskilled operators and secure against unauthorised users.

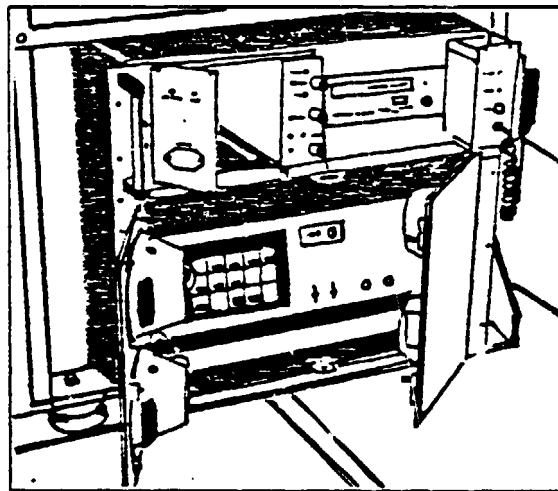
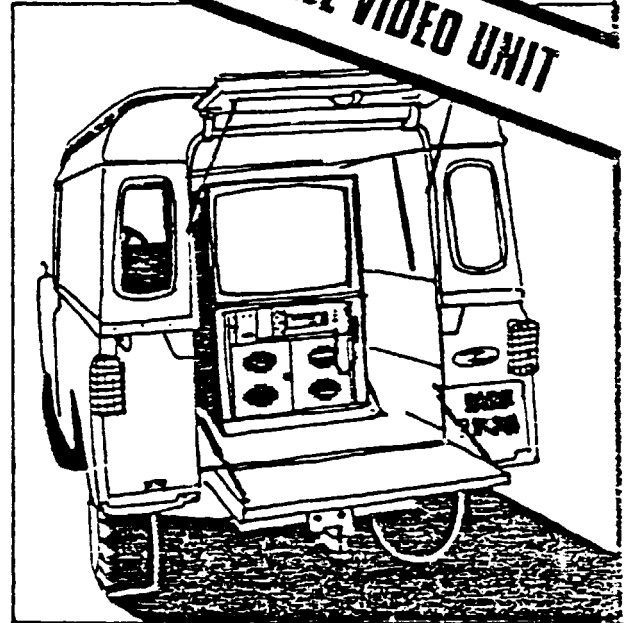

This system enables standard pre-recorded video cassettes to be shown in "bush" conditions while retaining the maximum security of equipment and being extremely simple to operate.

AUTO SYSTEM

SINGLE BUTTON "GO"

All functions sequenced by tones on unused audio track on VCP. Programmer is supplied to give up to fifty-nine commands.

The other elements in the electronics system are:

LED indications for "low power", "charging" and "charged", "overheat", "rewinding".

40 watts audio amplifier on 9u Eurocard.

Battery charger suitable for zero maintenance or conventional batteries.

Power changeover for internal or external mains, cycle time recorder.

THREE BUTTON MANUAL SYSTEM:-

BUTTON ONE push for "Start" - delays for monitor warm-up, tape lacing and VCP start. Second push gives still frame; third push for play. (V.C.P. = Video control panel)

BUTTON TWO Audio Cassette start with auto de-select of Video Monitor and VCP.

BUTTON THREE System stop:- Monitor off, VCP rewind; audio off: power off (from inverter, generator and mains); auto resets to start awaiting next command.

For further information, specifications and prices contact:

Agri-Visual Limited, 1 Rectory Road, Wokingham, Berkshire, United Kingdom. Tel: (0734) 790500 Telex: 847507G



2. Mobile Training Unit

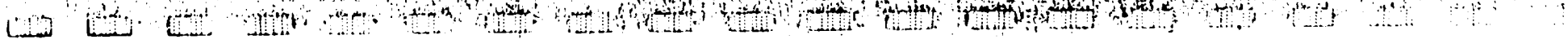

2.

MOBILE TRAINING UNITS

These are specially fitted vehicles (Landrover, Ford Transit van etc) which are suitable for audio-visual presentations to outside audiences.

Two alternatives are described. However, each supplier is completely flexible, and the enclosed versions are submitted as examples only.

1. British Films Ltd. M.T.U.

Price : sterling ^{approx.} £17,900 This unit is the same as that described in

2. Agrivisual Sector 3, but minus video equipment

Price : £ 22,035

**BRITISH
FILMS
LIMITED**

OUR REF: REL/CG/2048/83

Biograph House
251 Vauxhall Bridge Road
London SW1V 1EJ

Telephone 01-828 7965
Telex 947165

Mrs. Shirley A. Parfitt ATD, FSIAD,
Barley Mow Workspace,
10, Barley Mow Passage,
London W4 4PH.

SPECIFICATION

UNIDO PROJECT - EGYPT

MOBILE CINEMA AND VIDEO UNIT

One Land Rover: Long wheel base station wagon, Series III
4 cylinder petrol engine
Less middle bench and rear seats

LEFT HAND DRIVE COLOUR: BRONZE GREEN

Fitted with: Driver and passenger seats
Centre Power take-off
Engine speed governor
Governor position stop
Accelerator retaining bracket
Oil cooler equipment
Oil temperature gauge
Oil pressure gauge
Water thermometer
Electrical suppression for engine
Laminated windscreen glass
750 x 16 tyre equipment
Windscreen washers
Light fitted under bonnet
Spare wheel and carrier mounted on
de luxe bonnet with lock
- additional carrier on rear door
10 gallon (45 litre) additional fuel
tank with change-over tap beneath
driver's seat, change-over switch
for fuel gauge in dash panel.
Giving a total capacity of 26 gallons
(118 litres).

.../...



British Films Limited
Registered in England no 1657159
Registered office as above

Directors
W Shand Kydd
J Sherwin
P E. ...

Corrugated alloy platform assembly fitted to roof of vehicles.
Four rung steel ladder fitted to rear, to give access to roof platform.

Loudspeaker mountings fore and aft of roof.
Brackets for loudspeaker and screen mountings.

Built-in loudspeaker sockets.
Built-in cable drum for power supply.
Equipment stowage cabinet with access from side doors.
Stowage facilities for ancillary equipment.

Self-contained power supply provided by self-regulating alternator belt driven from centre power take-off unit on engine, producing 3 KVA 230 volt 50 cycles AC.

Electrical wiring in flexible conduit.
Electrical control panel with frequency meter, volt meter and voltage control regulator.

AUDIO-VISUAL EQUIPMENT

PROJECTION SYSTEM:

- 1 ~~Motor~~ Bell and Howell Model 2592 16mm projector with optical sound replay, built-in amplifier, speaker in side cover, with 51mm lens, matching unit and 1600ft spool. Power supply: Multi-voltage.
- 1 Zoom lens 35-65mm f1.6
- 1 High level demountable projector stand
- 1 Screen, matt white 8' x 6' (240cm x 180cm) for mounting on vehicle.
- 1 Screen mounting assembly
- 1 Indoor screen

AUDIO SYSTEM:

- 2 Re-entrant loudspeakers 30 watt output each
- 1 Omni-directional microphone with floor stand

ANCILLARY ITEMS:

- 1 16mm film rewinder
- 1 16mm film splicer
- 1 150 watt floodlight and stand
- 1 Mains distribution box
- 1 Set of cables for all systems

VIDEO SYSTEM:

- 1 JVC Model CP 5060 ET U Format Pal/Secam video cassette - recorder/play - still picture and full electronic remote control facility.
- 1 JVC Model RM88U Microprocessor based electronic editing control unit. Variable speed, tape shuttle search control forward/reverse.
- 1 JVC Portable professional video camera Model KY1900E110. Auto beam control. Built-in genlock, EBU colour bar generator - fully portable comprising:-

KY1900E camera head
H2 2100E 10:1 servo zoom lens
VF 1900E 1.5" viewfinder
AAC 19E AC Power adapter/charger
DC-C 19E NIC cad battery pack
VC 511/2 VTR cable whether (VTR 10 pin or 14 pin connector CB 1900V carrying case)

- 1 16mm telecine attachment to HZ2100E - zoom lens

Kodak carousel SAV 2010 slide projector complete with carrying case 150mm & 250mm lens slide tray, remote control and one lamp.

Bell and Howell overhead projector Model 1702K.
A4 format, lamp height adjuster lamp change mechanism, high quality (3.5, 317mm lens, 24V. 250 watt.
A1/223 lamps - Complete with:

Roll feed cassette
Dust cover
Cellofilm roll
3 acetate packs

- 1 Barco CS66 26" monitor

SPARES AND ACCESSORIES:16mm projector

- 3 1600ft spools
- 1 Integrated circuit for motor
- 1 Amplifier board
- 1 Main drive belt
- 6 Emm projector lamps
- 6 Exciter lamps
- 3 Sets of fuses
- 2 Gate brushes
- 1 Bottle of oil

Alternator:

- 1 Pair matched drive belts
- 1 Set AC brushes

Vehicle:

- 1 Set of engine belts
- 1 Set of plugs
- 1 Set of contact breaker points
- 1 Oil filter

Miscellaneous:

- 2 Speaker diaphragms
- 1 Inspection lamp, 12 volt with lead
- 1 Fire extinguisher
- 2 Cords with hook fitted for raising screen
- 2 Sets of spare lamp bulbs for inspection, interior and floodlight
- 1 Soldering iron
- 1 Reel of solder

Tools:

- 1 Set of Landrover vehicle tools
- 1 Set Allen keys
- 1 Pair pliers
- 1 Set 3A spanners
- 1 Pair side cutters

Manuals:

- 1 Filmobile set of operating instructions
- 1 Landrover vehicle manual
- 1 Bell and Howell service manual
- 1 Set of AV equipment instruction manuals
- 1 JVC equipment manuals

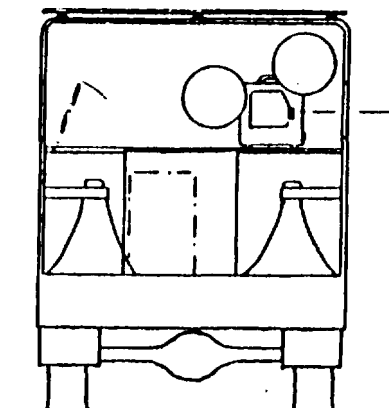
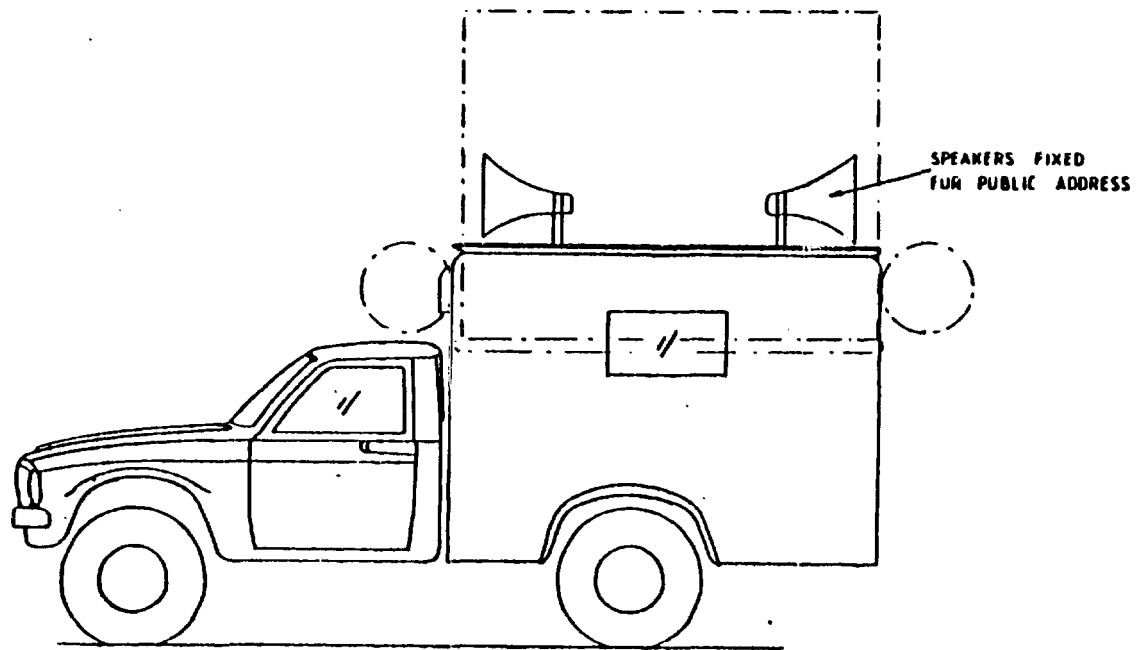
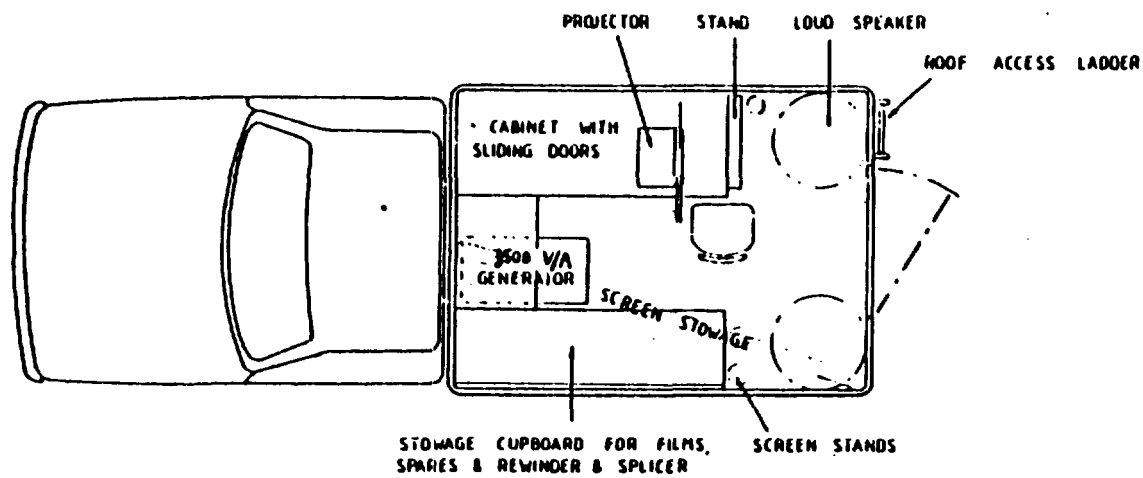

INTERIOR VIEW FROM REAR

FILMOBILE BASED ON A TOYOTA HI-LUX 4WD

DRAWING No 0188

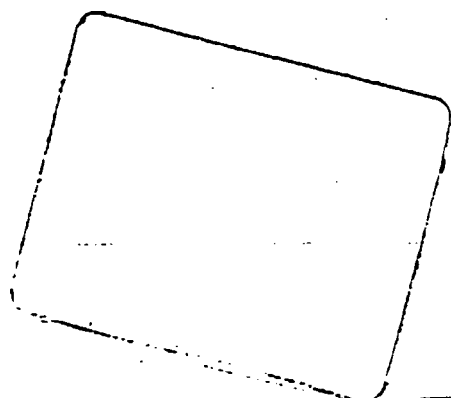

Fifty years experience

British Films Limited have been producing mobile audio visual units for over 50 years. The products and services available from the company today are the finest of their type in the world, and they represent a combination of the company's experience and expertise coupled with the use of the most reliable and advanced equipment obtainable.

In 1928, British Films manufactured mobile cinemas which were used by political parties and government departments for giving information to the man in the street. Today, British Films vehicles, built to travel over rugged terrain and to operate in all climatic conditions, can be found in over 90 countries.

In addition to the dependable Filmobile, British Films produce other purpose-equipped vehicles to customers' requirements. The company offers a complete design and consultancy service covering the whole spectrum of audio-visual activities. This service includes scripting and producing documentary films and audio-visual programmes; and British Films' producers have won top international awards for their documentaries.

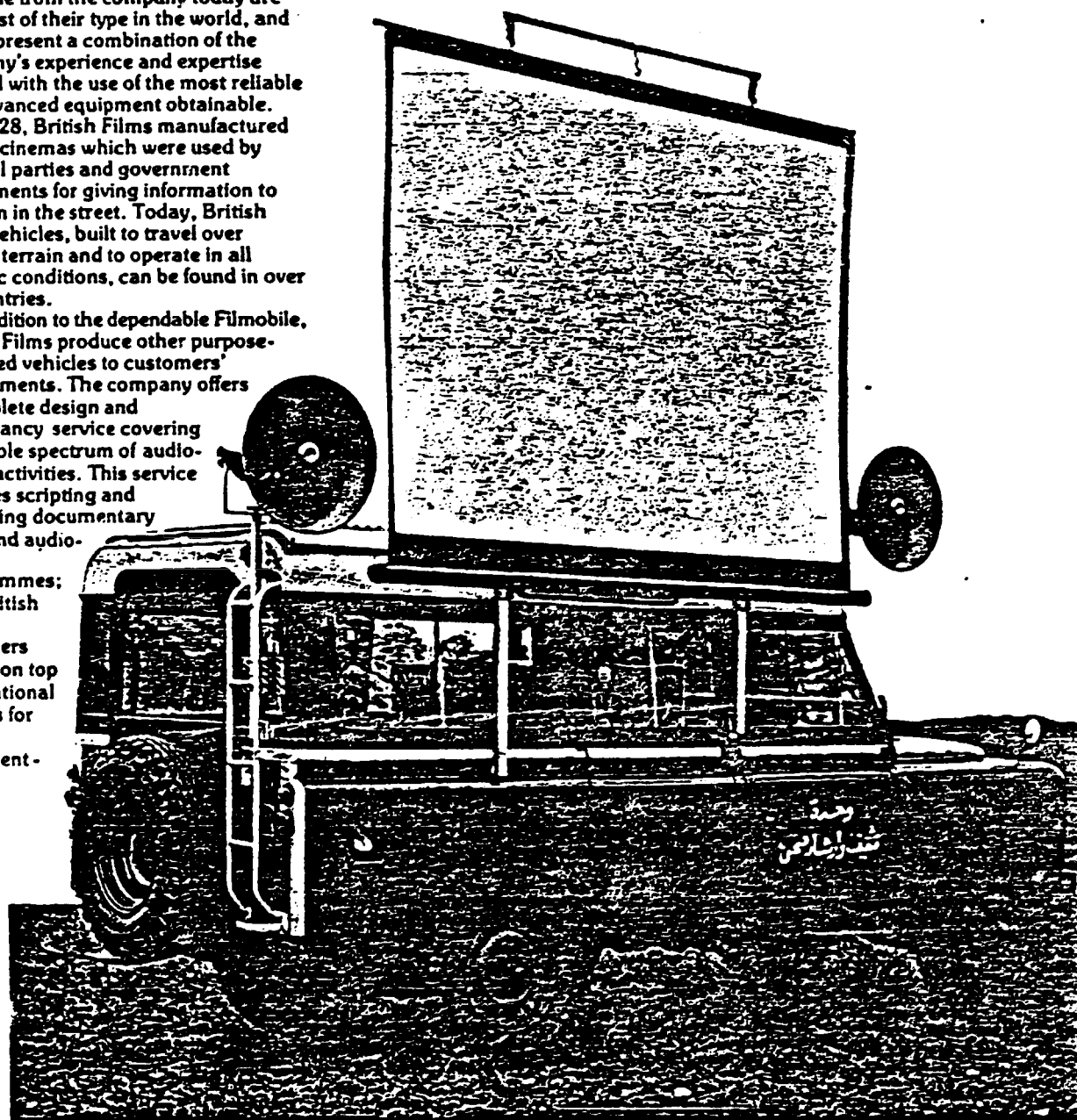

VARIATIONS

Medical equipment specification is dependent upon particular applications:
Specifications currently available are:

Mobile Medical Examination Clinic and Dispensary

Mobile Mother and Child Health Clinic

Mobile Emergency First Aid Clinic

Mobile Dental Clinic

Mobile Farm Tanning Clinic

Mobile Immunisation Unit

We shall be pleased to discuss alternative applications for the basic unit for other requirements.

The basic standard specification which applies to all variations is as follows:

Land Rover

The roof is fitted with a Solar Heat Shield and tent storage boxes built into each side running the complete length of the vehicle.

Metric Instrumentation. International lighting specification. Optional left or right hand drive.

Additional fuel tank with change over control giving a total fuel capacity of 118 litres (26 gallons imperial). Lockable fuel filler.

Heavy duty shock absorbers fitted at rear with driver springs all round. Steering damper.

A 4-cylinder petrol or Diesel engine with heavy duty alternator, split charge facility and extra engine cooling. Laminated windscreen. Five wheels and tyres (including one spare) dual purpose on/off road size 750 x 16. Spare wheel mounted onto deluxe dished bonnet.

Long wheel base (109 inch) fitted with a vertically hinged safari door with a rear window and foot access step.

Effective average range is:

4-cylinder petrol engine:
624 kilometres (390 miles)

4-cylinder diesel engine:
582 kilometres (364 miles)

This unique concept of tentage, permanently affixed to the left side and rear of the Land Rover allows for rapid assembly of a large enclosed working area. Tests have shown that the complete tentage system can be assembled by one man and be ready for operational use within thirty minutes of the vehicle arriving on site.

After use the system dismantles and packs away into the roof-mounted storage boxes with the same ease and speed.

The Filter Cover is manufactured from a top quality 12 oz. cotton canvas, completely water and rot proof using the "Birkmyr's" process which has been successfully applied and proven in use all over the world in both civilian and military applications for more than eighty years.

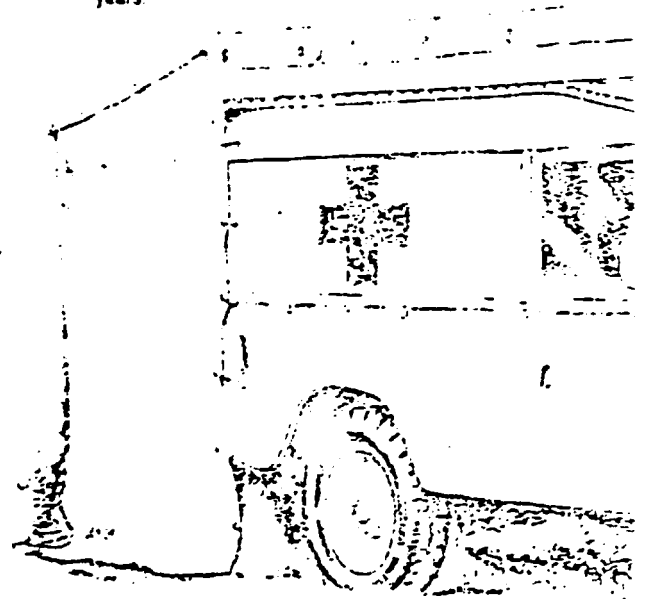

All mudflaps and sealing strips are polyester based PVC reinforced of knitted weight 20 oz.

Waterproofing Hydrostatic head water test up to 63.5 cms (25 inches).

The Inner Lining provides thermal insulation. Manufactured from "Hytex" 509 cotton cloth of approximately 4 oz to the square yard. All closures on the inner lining are made using "Velcro" fastening to allow the lining to be fastened (where thermal efficiency will be lost).

The Frame has been specially designed to be assembled by untrained personnel in the fastest possible time.

Manufactured from "Flo-Coat" steel tubing which has a bright galvanised finish applied during manufacture. The minimum number of pieces necessary to provide a strong and stable structure are used, being designed to socket together in a very simple manner by

Standard Equipment

Electrical System

Auxiliary Battery

12 volts, charged from the vehicle's spare charge facility, for operation of the refrigerator when the vehicle is in transit, emergency vehicle interior back-up lighting and generator's electric start.

Generating Set

4 KVA, 220 volt 50 Hz s/pbase, petrol or diesel driven, with electric start. Mounted inside rear of the Land Rover whilst in transit, the clinic has arrived on site, the generator is demounted from the vehicle.

Lighting

Electric lights with supply leads for mobile use inside tent. 220 volts.

Air Conditioning

A single unit of 6,500 BTU cold only, protruding through the tent end wall, supported upon a substantial metal stand.

Refrigerator

With top opening lid 12-volt, 220 volt AC or gas or 12 volts DC, warning light when operating on 12 volts. Capacity 34 litres (1.4 cubic feet).

Storage and Equipment

Cabinetry is fitted into the Land Rover to provide the maximum amount of secure storage for equipments. The amount of cabinetry fitted is dependent upon the ultimate equipment specification.

Two Gas Bottles

Mounted in a carrying frame.

Table

Stabilised with clips to side of vehicle tent interior (except for Mobile Dental where table is free standing).

Storage Bag for Table

(and examination couch where supplied)

Double Ring Gas Stove

portable.

Two Folding Chairs

Three Portable Fold-up Camp Beds

Two Water Containers with Fitted Taps

Two simple Disposable Water Purification Units (8,000 litres life each).

One Hand Wash Bowl

Fire Extinguisher

Dry powder

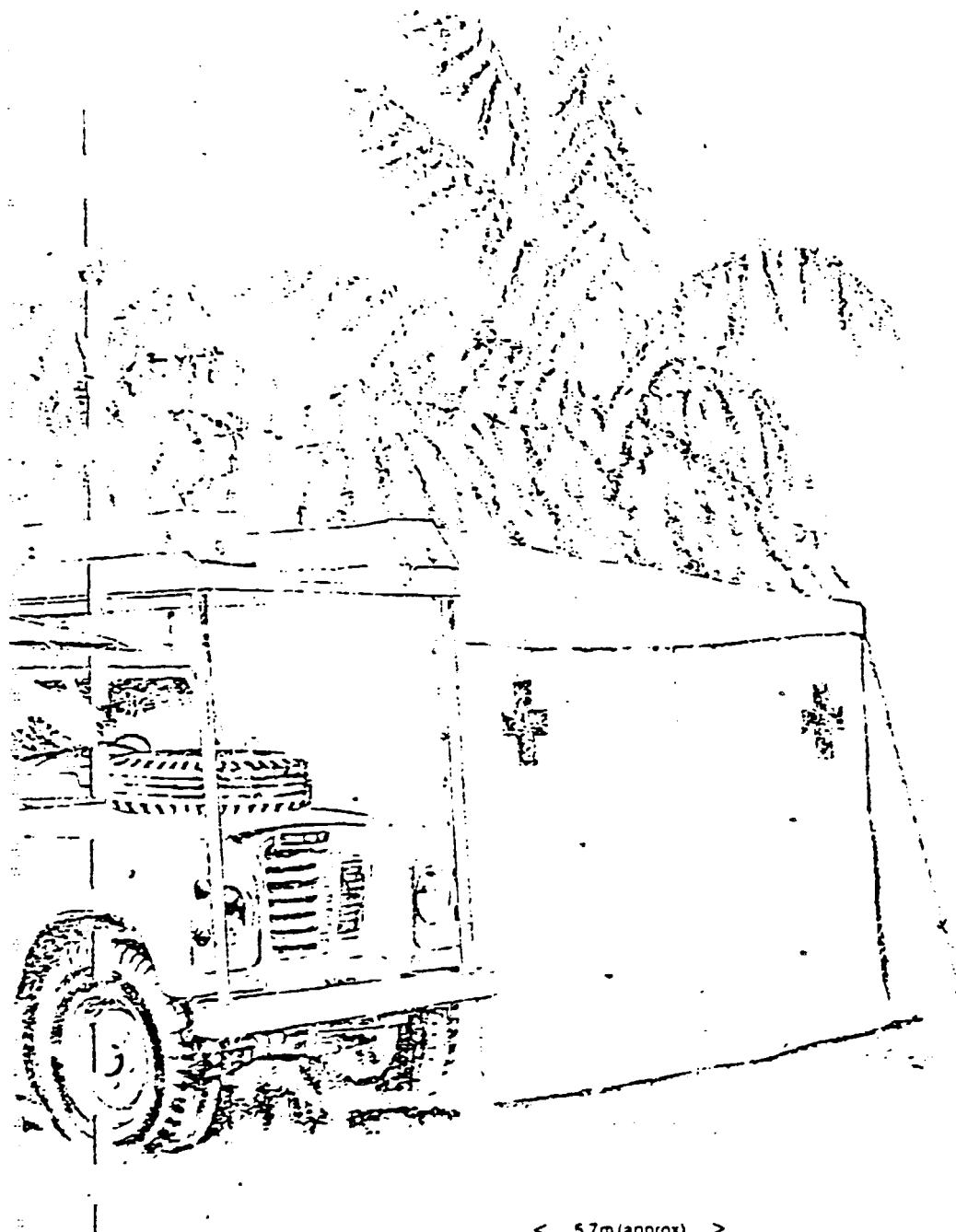

< 5.7m (approx) >

...e necess... for tools, nuts, bolts...
...small fittings which could be...
...or lost. All legs are completely...
...so that the frame can be...
...on uneven terrain. The frame...
...the Land Rover by means of self-...
...cets.

...This special design of tentage...
...is relatively efficient...
...working area of approximately...
...metres (182 square feet).

...or areas of 192 square metres.

...The height from ground to tent ceiling...
...at Land Rover wall, 2.1 metres...
...minimum of outer wall of...
...feet).

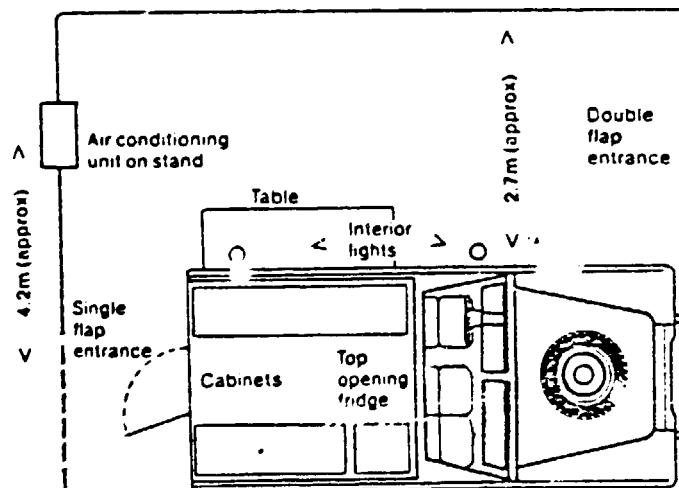

British
Films

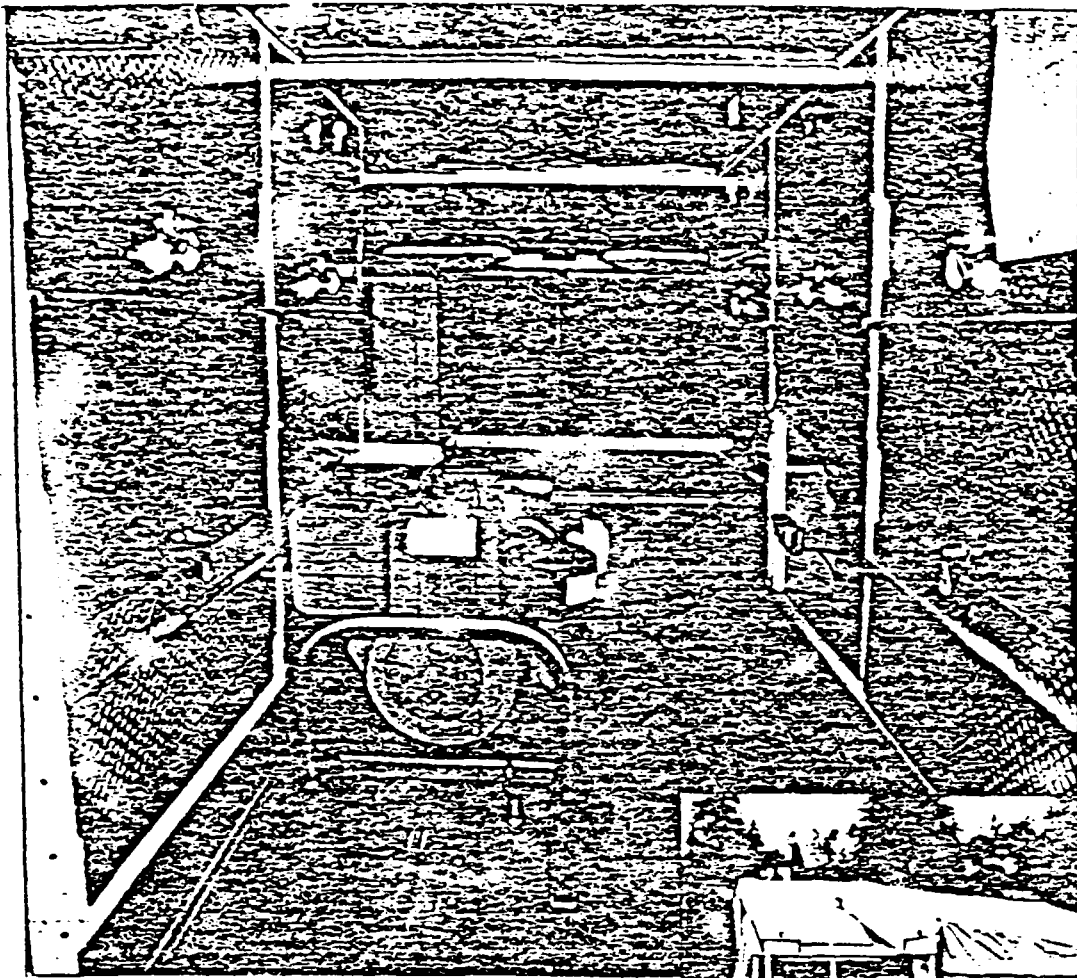

Above: Interior of Land Rover showing cabinets and portable generating set.
Right: Front view of vehicle and tent showing double flap entrance.

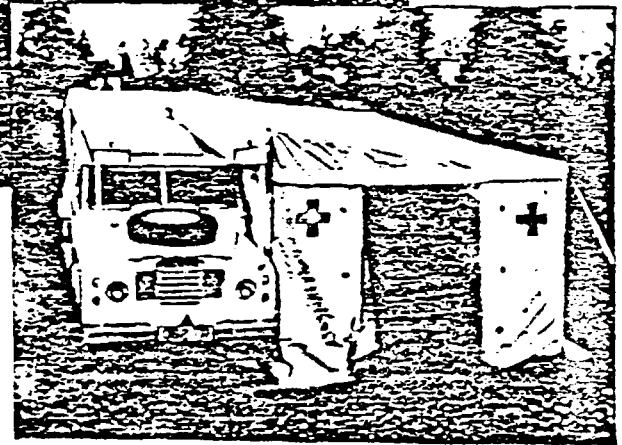

Optional References

Please quote these references when requesting quotations and clinic specifications.

P1 Land Rover

109 inch wheelbase with 4-cylinder petrol engine. Standard unit with 6,500 BTU air conditioning. (Cold only).

P2 Land Rover

109 inch wheelbase with 4-cylinder petrol engine. Complete with air circulatory fans and infra-red heaters for use in temperate climates.

P3 Land Rover

109 inch wheelbase with 4-cylinder diesel engine. Standard unit with 6,500 BTU air conditioning. (Cold only).

P4 Land Rover

109 inch wheelbase with 4-cylinder diesel engine. Complete with air circulatory fans and infra-red heaters for use in temperate climates.

Optional Specification

The details overleaf describe the standard basic unit. An alternative for use in temperate climates is available without the air conditioning unit, but supplied with:

- TWO - 220-volt air circulatory fans.
- TWO - Infra-red heaters 1kw each.



POOLCO

Specialists In Mobile Health Care
Gordon L Foote & Co Ltd.

Cardyle House, 235 Vauxhall Bridge Road, London SW1V 1EJ
Tel: 01-828 7965 Cables: POOLCO London SW1 Telex: 947165

MOBILE TRAINING UNIT

The Agri-Visual Mobile Training Unit is specifically designed for modern mass communications using the latest Audio-Visual, Exhibition and Demonstration techniques. It is ideal for Education, Agricultural Development Programmes and Sales Promotion where the potential audiences are numerous and widely spread.

Within minutes of arrival the MTU can project a film during the day or night. On the move or stationary, programme information and pre-recorded messages or slogans can be broadcast using the Versatile Public Address system.

All equipment remains fixed for both Front and Rear Projection, only the generator is moved from the vehicle. The Rear Projection screen is shaded by an easily erected awning. The all-weather speakers are roof-mounted. Exhibition Panels are incorporated for displaying flipcharts, photographs, posters and other support information for Demonstrations.

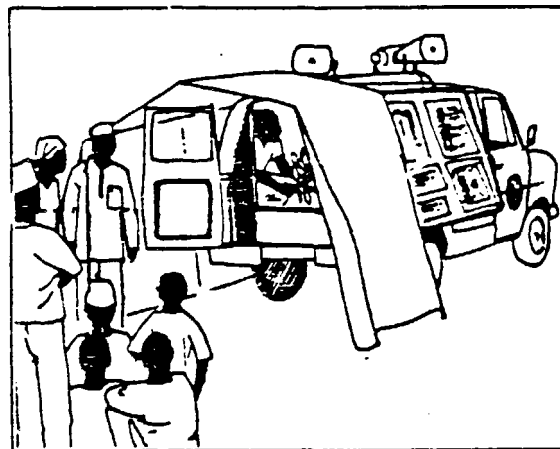

Field Demonstrations: Training, promotion and demonstration can be given to a large audience with the PA system.

Audio: Extensive Audio Facilities enable Programmes to be played and Speeches to be made. The System allows Programmes to be interrupted by the Presenter to add his own material.

Visual: 16mm film, tape/slide and illustrated lectures can be given by day or night.

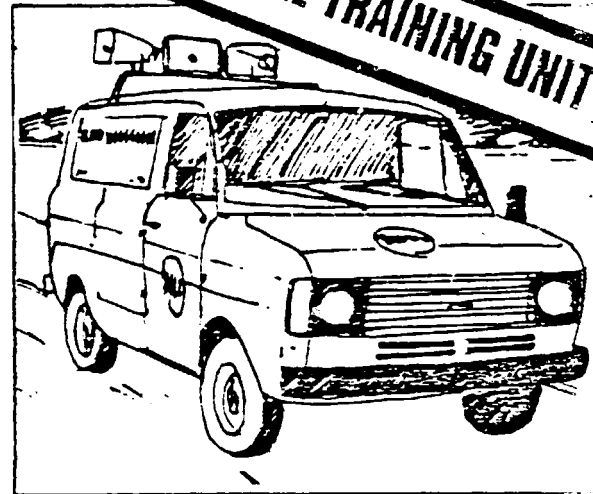

Exhibitions: Display boards are inclusive and there is space for Exhibition materials and models.

The Agri-Visual Mobile Training Unit projects films to large audiences by day or night and the public address system can broadcast information with the vehicle in motion.

Information: National and International Rural News
Agricultural Shows and Exhibitions
Social, Political etc.,
Information
Trade Fairs.

Agriculture: Farmer Training
Staff Training
Farmer Information
Promotion of New Technology

Education: Rural Education Programmes
Mobile School/Lecture Platform
Mass Education
Literacy Campaign

Health: Public Health Programmes
Mass Information on
Innoculation.

For further information, specifications and prices contact:

Agri-Visual Limited, 1 Rectory Road,
Wokingham, Berkshire, United Kingdom.
Tel: (0734) 790500 Telex: 847507G



MOBILE TRAINING UNIT

Specification and Prices

The latest edition of the AGRI-VISUAL Mobile Training Unit is based on the new LAND ROVER 110 Series.

Vehicle specification is as follows:

CHASSIS	a development of the world-renowned RANGE ROVER, with long travel coil springs all round, lighter and improved steering.
ENGINE	either 2½ litre petrol or diesel 4-cylinder, or 3½ litre V8 petrol, all with five bearing crankshafts.
TRANSMISSION	FIVE speed gearboxes on all 4-cylinder models, and all with a completely new transfer box. Permanent 4-wheel drive and centre-differential lock.
BODYWORK	redesigned interior and exterior and controls.
BRAKES	Servo-assisted disc brakes at front with dual circuit.

All in all, greater flexibility through the gears, improved fuel economy, smoother and quieter cruising, better handling and control.

Optional extras - include self-levelling suspension, power-assisted steering, air-conditioning.

Our basic, standard specification for the well-proven AGRI-VISUAL Mobile Training Unit is just as exciting.

Internally - BELL & HOWELL MAGNETIC & OPTICAL sound projector to professional standard, complete with operating kit of spare lamps, belts and toolkit. Top quality 40 watt amplifier controlling the front compartment microphone and cassette player and feeding three 15 watt roof horn speakers mounted on a special rack. All the equipment is housed in a craftsman-made laminated security cabinet, skinned with tough aluminium alloy and housing a specially designed generator to supply all the electrical power requirements.

Included, as a study of the equipment inventory will reveal, is a full-size lightweight folding screen of a size 8' x 6' (244 x 183cm) based on a 1" square-section aluminium alloy tube, packed in a stout travelling case.

The Mobile Training Unit is supplied with everything that is required to run and maintain the unit with the minimum of effort and downtime.

The standard specification is as follows:

DRIVING COMPARTMENT:

12 Volt Cassette Player
Hand Microphone*

MAIN COMPARTMENT:

Specially designed security cabinet with two locks. Bell and Howell 16 mm magnetic/optical sound projector (complete with standard lens, four spare projector lamps, two spare exciter lamps, spare belts, fuses, speed control unit). Instruction book and parts manual for above.

Mains lead and extension leads for mains and amplifier leads.* Projector stand (for external use if needed). Set of empty spools (three).

Complete film rewind and repair kit, comprising rewinder board with rewind arms (one geared), splicer and tape splices. lens cloth, aerosol and refilling pump for dusting.

Security screen and partition at rear of driving compartment, complete with roller shade blind.

*40 watt amplifier.

*Three - 15 watt roof horn speakers on special mount.

*One stand microphone and lead, with tripod folding stand.

One generator 1.8 KVA (petrol driven).

Spare spark plugs, gaskets, starter spring and cord etc., as necessary for 200 hours operation.

Five litres oil, one - 20-litre steel fuel container.

One funnel.

One plug spanner.

[One general toolkit - two pliers, three screwdrivers, test meter soldering iron and solder.

One cable-drum with 20m heavy duty cable and duraplug, twelve cable pegs.

One cable-drum to control unit.

One - 12 volt clip-lamp with special three pin plug and fitted mating socket.

One - 240 volt clip-lamp. Both above with adequate supply of spare bulbs.

*One lightweight folding screen 8' x 6' in special case with guys, pegs, etc.

Two display pinboards with supply of pins.

One fire extinguisher (mounted).

* ie - remove matt white front projection surface of the screen and replace it with a rear projection surface for the screen.

OPTIONAL ADDITIONS AT EXTRA COST

A REAR-PROJECTION EQUIPMENT consisting of:

- Special reversing lens
- Rear-projection roller screen 3' x 2' fitted to rear upper hatch of Land Rover.
- * Rear-projection surface for folding 8' x 6' screen.
- Shade awning for rear of vehicle complete with extending poles, guys, pegs and bag, for daytime viewing.

B SLIDE PROJECTOR

with or without cassette recorder/player, linked to control.

Comprehensive instructions to set up, operate and maintain equipment are detailed in the instruction manual supplied with each unit.

Short courses of instruction may be arranged on site if required.

PRICES :-

? Basic inventory all fitted into MK III 109" Land Rover with tropical roof (4 cylinder petrol)
FOB UK PORT £19,250.00

Basic Inventory all fitted into the latest Land Rover 110 with tropical roof (4 cylinder petrol)
FOB UK PORT £19,750.00

AVAILABLE EXTRAS

	Approx Costs
Air conditioning for vehicle	£750.00
Power steering	£320.00
Rear projection kit (as listed)	£765.00
Slide projector (only)	£450.00
Slide projector and controlling cassette recorder/player	FOA

Delivery eight - ten weeks subject to vehicle availability.

These prices are correct at going to press

September 1983

MTU

MOBILE TRAINING UNIT



The Agrivisual Mobile Training Unit projects films to large audiences by day or night and the public address system can broadcast information with the vehicle in motion.

The Agrivisual Mobile Training Unit has been used successfully for Mass Education, Farmer Training, Rural Health Campaigns and General Promotion. It is the most versatile Training Unit available.



AGRIVISUAL



MTU

The Agrivisual Mobile Training Unit is specifically designed for modern mass communications using the latest Audio, Visual, Exhibition and Demonstration techniques. It is ideal for Education, Agricultural Development Programmes and Sales Promotion where the potential audiences are numerous and widely spread.

Within minutes of arrival, the MTU can project a film during the day or night. On the move or stationary, programme information and pre-recorded messages or slogans can be broadcast using the Versatile Public Address system.

All equipment remains fixed for both Front and Rear Projection, only the generator is moved from the vehicle. The Rear Projection screen is shaded by an easily erected awning. The all-weather speakers are roof-mounted. Exhibition Panels are incorporated for displaying flipcharts, photographs, posters and other support information for Demonstrations.

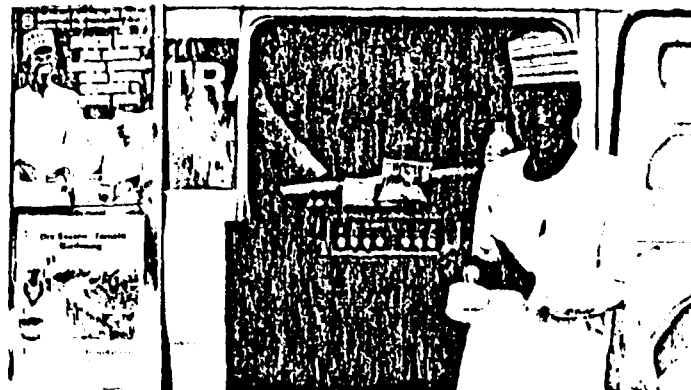

MTU Operators are trained by our experienced Staff under field conditions to ensure they receive practical instruction in maintenance and operation.

Where there is a need to Inform, Promote, Teach, Educate and Motivate, the Agrivisual Mobile Training Unit provides a highly efficient and versatile communications system.

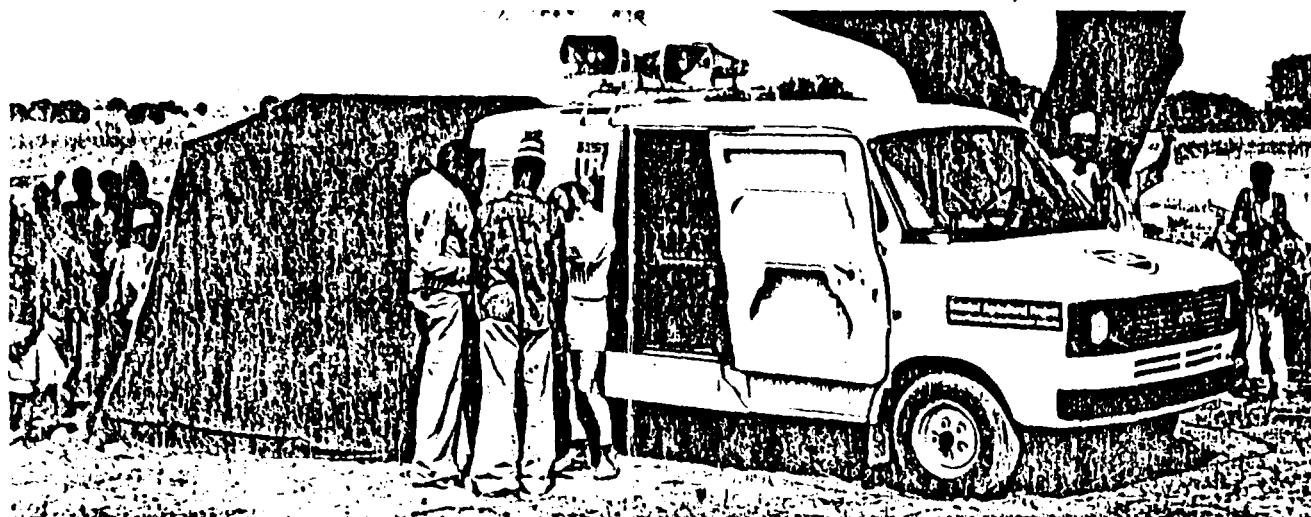

EFFECTIVE COMMUNICATIONS

Field Demonstrations: Training, promotion and demonstration can be given to a large audience with the PA system.

Audio: Extensive Audio Facilities enable Programmes to be played and Speeches to be made. The System allows Programmes to be interrupted by the Presenter to add his own material.

Visual: 16mm film, tape/slide and illustrated lectures can be given by day or night.

Exhibitions: Display boards are inclusive and there is space for Exhibition materials and models.

MOBILE COMMUNICATIONS

Information: National and International Rural News
Agricultural Shows and Exhibitions
Social, Political etc. Information
Trade Fairs

Agriculture: Farmer Training
Staff Training
Farmer Information
Promotion of New Technology

Education: Rural Education Programmes
Mobile School/Lecture Platform
Mass Education
Literacy Campaign

Health: Public Health Programmes
Mass Information on Innoculation

AGRIVISUAL LTD., 1 Rectory Road, Wokingham,
Berkshire, UK. Tel. (0734) 790500 Telex 847507 G

Land Rover.

POWER TAKE-OFF for a work horse



Power Take-Off

An important part of Land Rover's versatility is the flexibility of its PTO facility which provides a static or mobile power source. The power is available at three basic positions on the vehicle where a coupling can be made to the engine power.

The transfer gear drive unit consists of a centre and bottom PTO which can be obtained as optional

equipment. They form the basic drive for three variations of PTO.

Centre PTO — where power can be transmitted to machinery mounted in place of the passenger seats, below the rear body floor or within the rear body section.

Rear PTO — from where machinery mounted on the rear of the vehicle or on a trailer (or on any remote mounting) can be powered. A trailer

powered in this way will cross the most arduous terrain. **Bottom PTO** — this is an auxiliary gearbox attached at the base of the transfer gearbox to which you can add the same drive units used at the centre PTO.

When the centre PTO is used for other purposes a hydraulic winch can be powered from the bottom PTO.

A selected range of equipment can also be driven directly from the

Engine Crankshaft

The PTO units are easy to fit and can be supplied with the vehicle in mechanical, belt or hydraulic drive versions. Other optional equipment you may find useful to use with PTO equipment is a hand throttle, engine governor, oil cooler, engine speed counters and hour meters.

The PTO capability was part of Land Rover design from its

- 6. Capstan winch
 - 7. Rear PTO
 - 8. Mobile workshop (centre PTO)
 - 9. Detachable hydraulic winch.
 - 10. Hydraulic drum winch driven from the centre PTO
 - 11. Bottom PTO with hydraulic pump
 - 12. Centre PTO with direct 'V' belt drive
 - 13. Rear PTO with 'V' belt drive
 - 14. Rear PTO with drive shaft
 - 15. Centre PTO with drive shaft to ancillary equipment
 - 16. Centre PTO with drive shaft to outrigger bearing.
- (12-16. Shaft, outrigger bearing and pulleys supplied by approved converters and suppliers.)

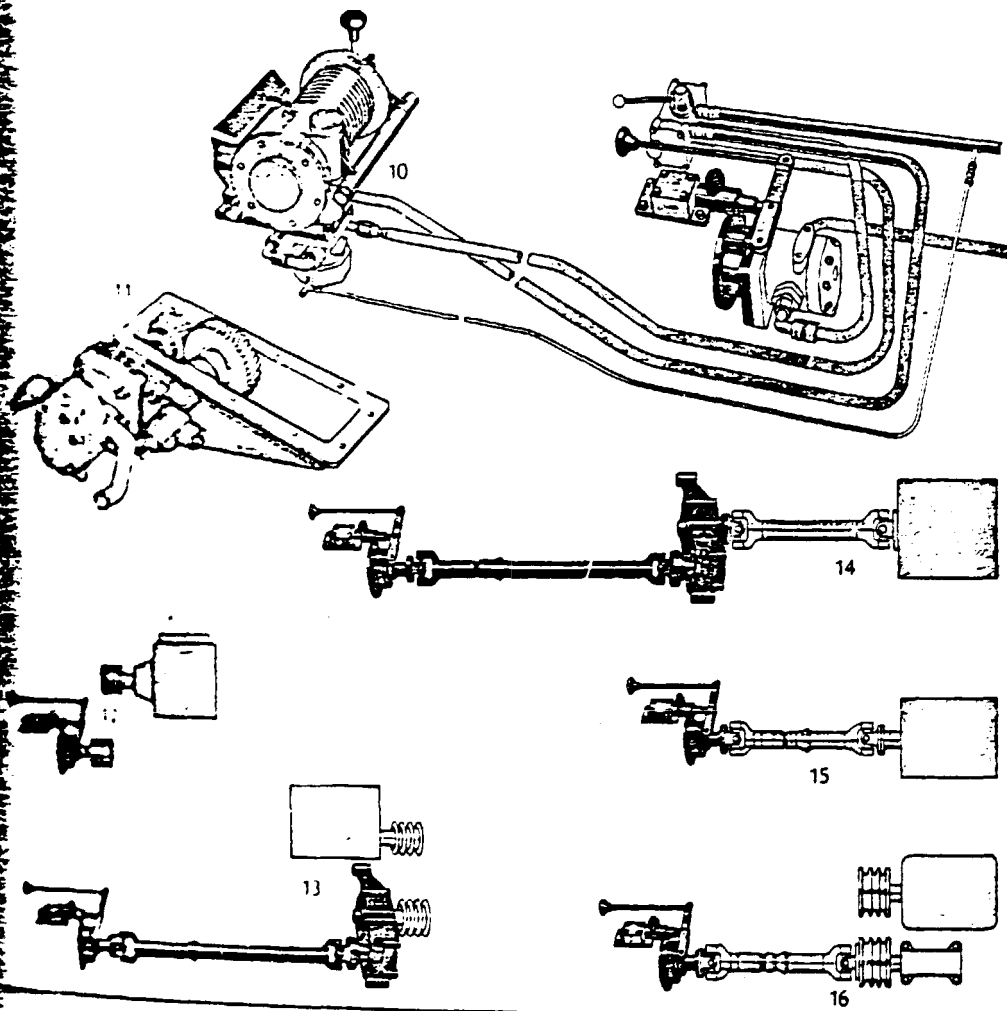
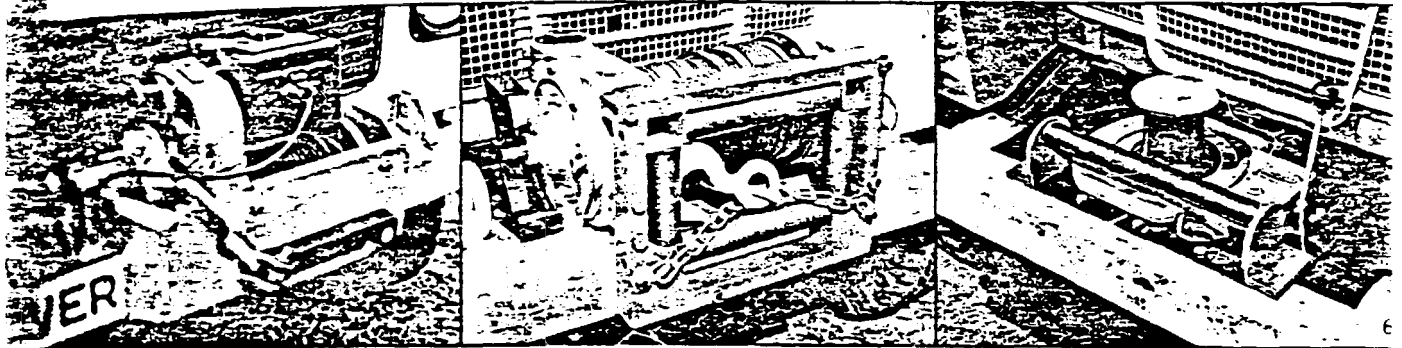





...the variety of PTO...
 ...There...
 ...tools...
 ...equipment...
 ...Dealer for...
 ...range of...
 ...suppliers for

the vast number of Land Rover special conversions.
Winches. Winches are very important for a large number of jobs such as construction, or cable laying and all types of vehicle and equipment recovery.
 Land Rover have a wide range of winches in mechanical, electrical and hydraulic form to cater for all your requirements. Your Land Rover

Dealer will recommend the most suitable winch for your vehicle and your specific needs. The basic types are:
Capstan - mechanical, driven from the engine crankshaft.
Detachable - hydraulic, driven from the centre or bottom PTO.
Drum - electric, driven from the vehicle's battery.
 - hydraulic, operated from

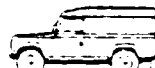
the centre or bottom PTO points.
 - mechanical, driven from the centre PTO.
 Land Rover is more than a supremely practical means of transport, it is an extremely hardworking and highly mobile power source for all applications.

The new Land Rover One Ten Price List UK Effective 8 March 1983

Description	List Price	Vat	Car Tax	Max. Rec. Ret. Price	Description	List Price	Vat	Car Tax	Max. Rec. Ret. Price
 Pick Up 2 1/4 P 6948.00 1042.20 Nil 7990.20	2 1/4 D 7783.00 1167.45 Nil 8950.45	3 1/2 P 7757.00 1163.55 Nil 8920.55	 Soft Top 2 1/4 P 6964.00 1044.60 Nil 8000.60	2 1/4 D 7797.00 1169.55 Nil 8900.55	3 1/2 P 7773.00 1165.95 Nil 8938.95				
 HCPU 2 1/4 P 7357.00 1103.55 Nil 8460.55	2 1/4 D 8192.00 1228.80 Nil 9420.80	3 1/2 P 8166.00 1224.90 Nil 9390.90	 Station Wagon 2 1/4 P 8087.00 1213.05 Nil 9300.05	2 1/4 D 8922.00 1338.30 Nil 10260.30	3 1/2 P 8914.00 1337.10 Nil 10251.10				
 Hard Top 2 1/4 P 7357.00 1103.55 Nil 8460.55	2 1/4 D 8192.00 1228.80 Nil 9420.80	3 1/2 P 8166.00 1224.90 Nil 9390.90	 County SV 2 1/4 P 8461.00 1269.15 Nil 9730.15	2 1/4 D 9296.00 1394.40 Nil 10690.40	3 1/2 P 9287.00 1393.05 Nil 10680.05				

OPTION PACKS

Description	Model Type	List Price	VAT	Max. Rec. Ret. Price	Description	Model Type	List Price	VAT	Max. Rec. Ret. Price
INTERIOR APPOINTMENT PACKS					PROTECTION PACKS				
A	One Ten S/Top	270.00	40.50	310.50	1	(Ex County SW) All One Ten	30.00	4.50	34.50
	One Ten H/Top	310.00	46.50	356.50		Fire Extinguisher Bonnet Lock Fuel Filler Lock Facility			
	3 County Cloth Seats Head Restraints (2 x Front Outer)				2	(Ex County SW) All One Ten	60.00	9.00	69.00
	Full Interior Cab Trim					Fire Extinguisher Bonnet Lock Fuel Filler Lock Facility Radiator Chaff Guard Front & Rear Lamp Guards			
B	One Ten H/Top & S/Top	169.00	25.35	194.35	3	All One Ten	25.00	3.75	28.75
	3 County Seats Head Restraints (2 x Front Outer)					Front Mud Flaps, Bonnet Lock Fuel Filler Lock Facility			
C	One Ten SW (Station Wagon)	283.00	42.45	325.45	TOWING PACKS				
	12 County Seats Head Restraints (2 x Front Outer)				1	All One Ten	60.00	9.00	69.00
D	One Ten PU & HCPU	305.00	45.75	350.75		Towing plate, Front Towing Rings, 50mm Ball or Jaw, 7 pin Trailer Electrics (Please specify)			
	3 County Seats Full Interior Cab Trim				2	All One Ten	25.00	3.75	28.75
E	One Ten PU & HCPU	231.00	34.65	265.65		Towing plate, Front Towing Rings, 50mm Ball or Jaw (Please specify)			
	One Ten H/Top & S/Top	273.00	40.95	313.95	3	All One Ten	50.00	7.50	57.50
	3 Deluxe Vinyl Seats Full Interior Cab Trim					Towing plate, Front Towing Rings, 7 Pin Trailer Electrics			

NOTES:

- Full Interior Cab Trim includes High-Density rubber floor covering, Door Trim with remote Lock handles and moulded fibre headlining in cab section (except Soft Top model).
- County cloth seats when ordered as an option will be Black/Grey. In County Station Wagons the standard seat trim is County Cloth in Brown/Beige.
- Protection Packs 1 and 2 - not available on County Station Wagon.
- Electrical Pack A, Interior Trim Pack C, Quartz Clock, Laminated Windscreen, Spare Wheel Cover, Tinted Glass and Front Mud Flaps are Standard on the County Station Wagon. Please refer to the Sales Brochure for comprehensive specification details.

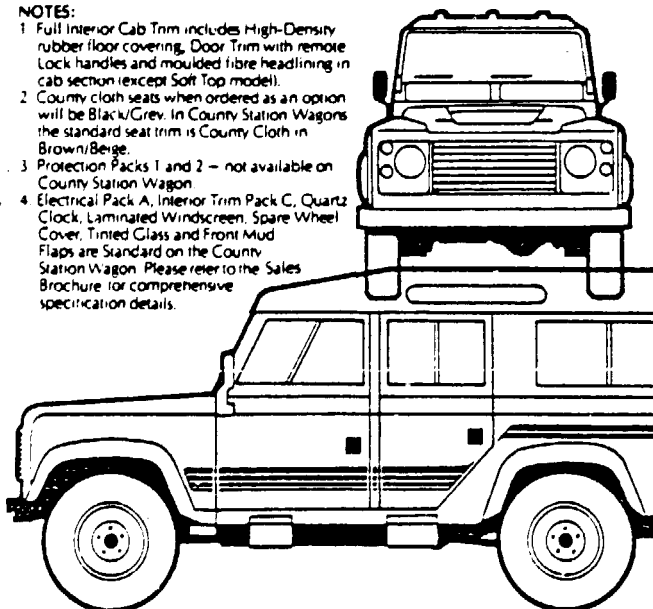

AUXILIARY CHARGING PACK

All One Ten 111.00 16.65 127.65

25 ACR 65A Alternator Split Charge Facility Voltmeter

HEAVY DUTY ELECTRICAL PACK

All One Ten 78.00 11.70 89.70

18 ACR 45A Alternator Heavy Duty Battery Voltmeter

ELECTRICAL APPOINTMENT PACK (Standard on County SW)

All One Ten 30.00 4.50 34.50

Quartz Clock, Voltmeter, Side Repeater Flashers, Quartz Halogen Headlamp

TRANSMISSION PACK

2 1/4 Litre Models 200.00 30.00 230.00

Selectable 2/4 Wheel Drive, Free Wheeling Front Hubs

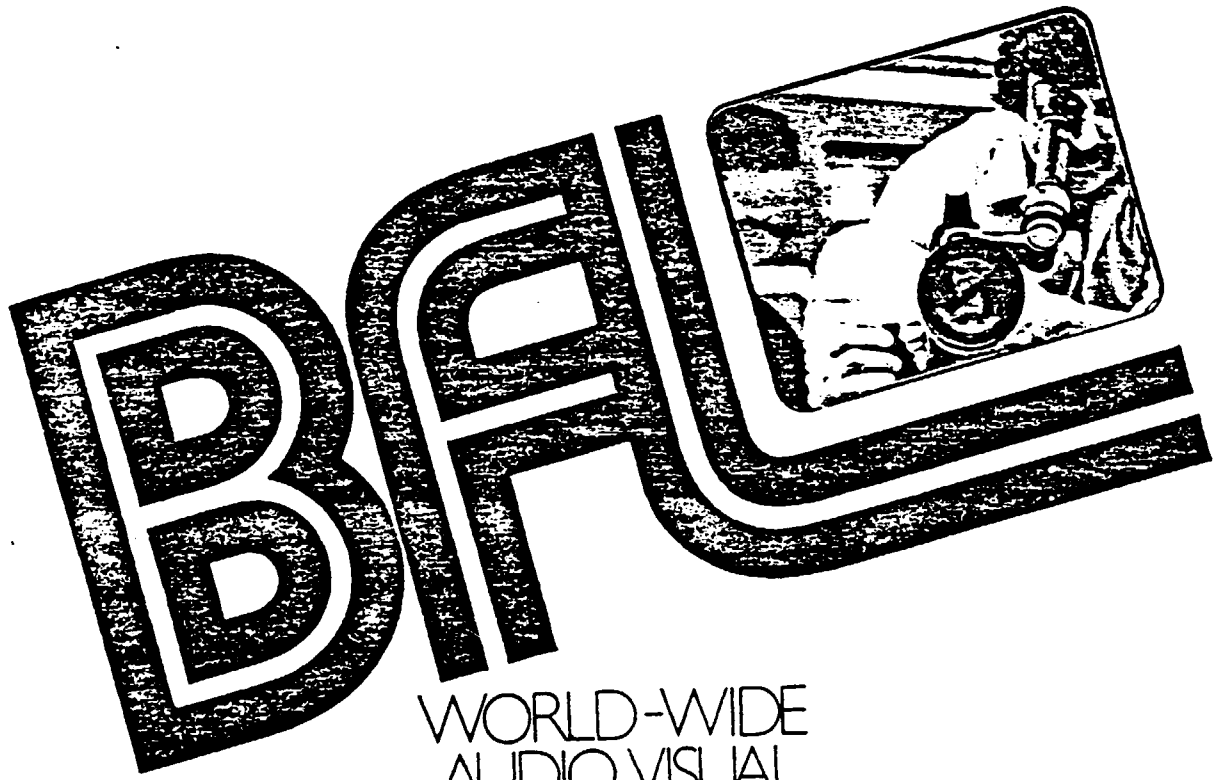

WORLD-WIDE
AUDIO VISUAL
COMMUNICATIONS

BRITISH FILMS LIMITED



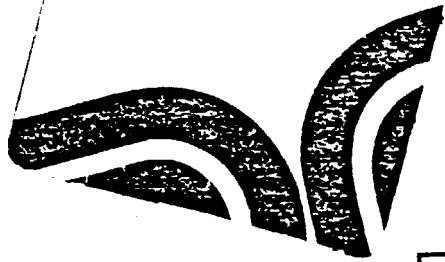

Fifty years experience

British Films Limited have been producing mobile audio visual units for over 50 years. The products and services available from the company today are the finest of their type in the world, and they represent a combination of the company's experience and expertise coupled with the use of the most reliable and advanced equipment obtainable.

In 1928, British Films manufactured mobile cinemas which were used by political parties and government departments for giving information to the man in the street. Today, British Films vehicles, built to travel over rugged terrain and to operate in all climatic conditions, can be found in over 90 countries.

In addition to the dependable Filmobile, British Films produce other purpose-equipped vehicles to customers' requirements. The company offers a complete design and consultancy service covering the whole spectrum of audio-visual activities. This service includes scripting and producing documentary films and audio-visual programmes; and British Films' producers have won top international awards for their documentaries.

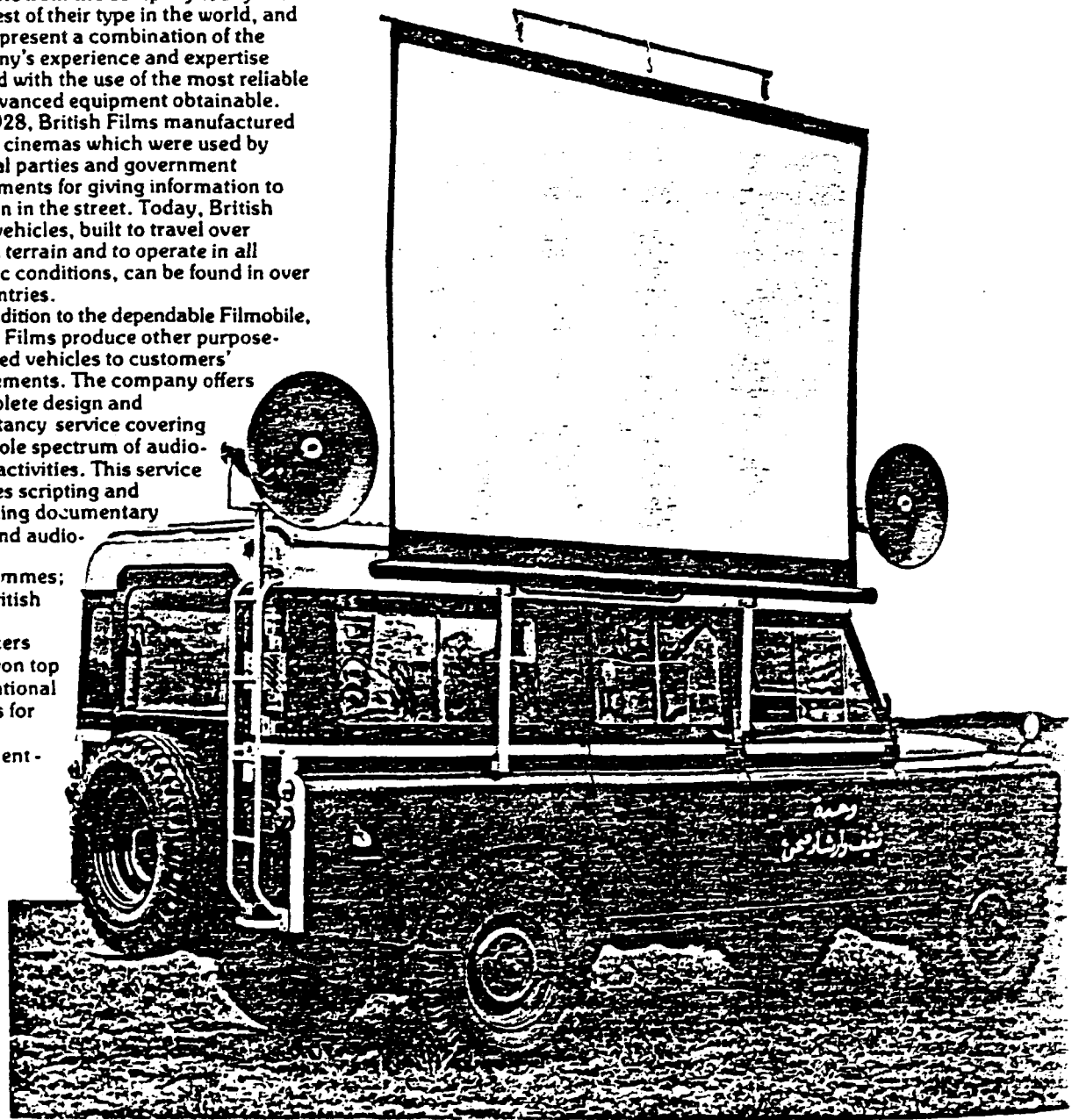

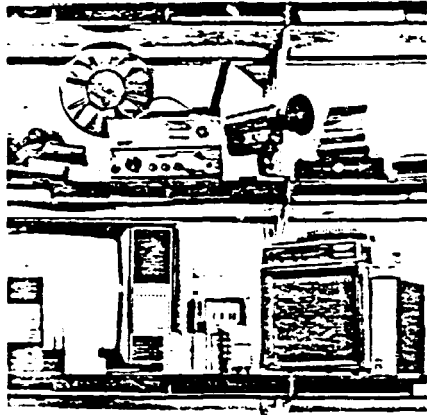

EQUIPMENT SUPPLY

British Films are distributors of many of the world's leading makes of film, video and audio-visual equipment.

Because of the company's expertise, advice is available to help customers decide on the most suitable type of equipment for their requirements.

One of the British Films facilities most appreciated by overseas clients is their rapid service for the supply of accessories and spare parts.

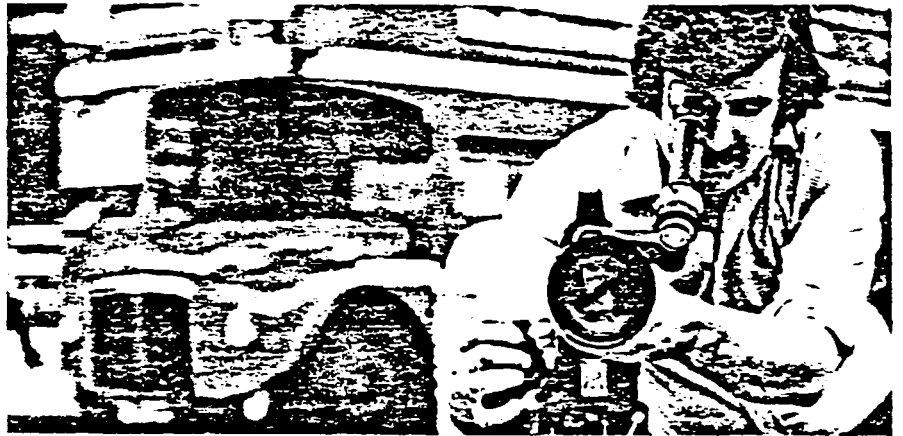

PRODUCTION SERVICES

After 50 years, British Films are still among the leading documentary film producers, with more than 60 national and international awards to their credit. Sponsors include the international agencies, government departments of several countries, the Armed Services, education, science and industry.

The film units attached to ministries of information and broadcasting, health, agriculture etc of many countries rely on British Film production services for negative processing, editing, sound-tracking etc, while training facilities for their film technicians can be arranged both in the UK and overseas.

THE COMMUNICATIONS CONSULTANTS

With 50 years experience behind them, British Films can offer their customers advice and expert assistance on any aspect of audio-visual communication from the selection of the medium to the treatment of the story, through all stages of production in film, slide-tape or video, to completion and subsequent presentation.

British Films is a world-wide consultancy service covering every facet of visual and audio communication.

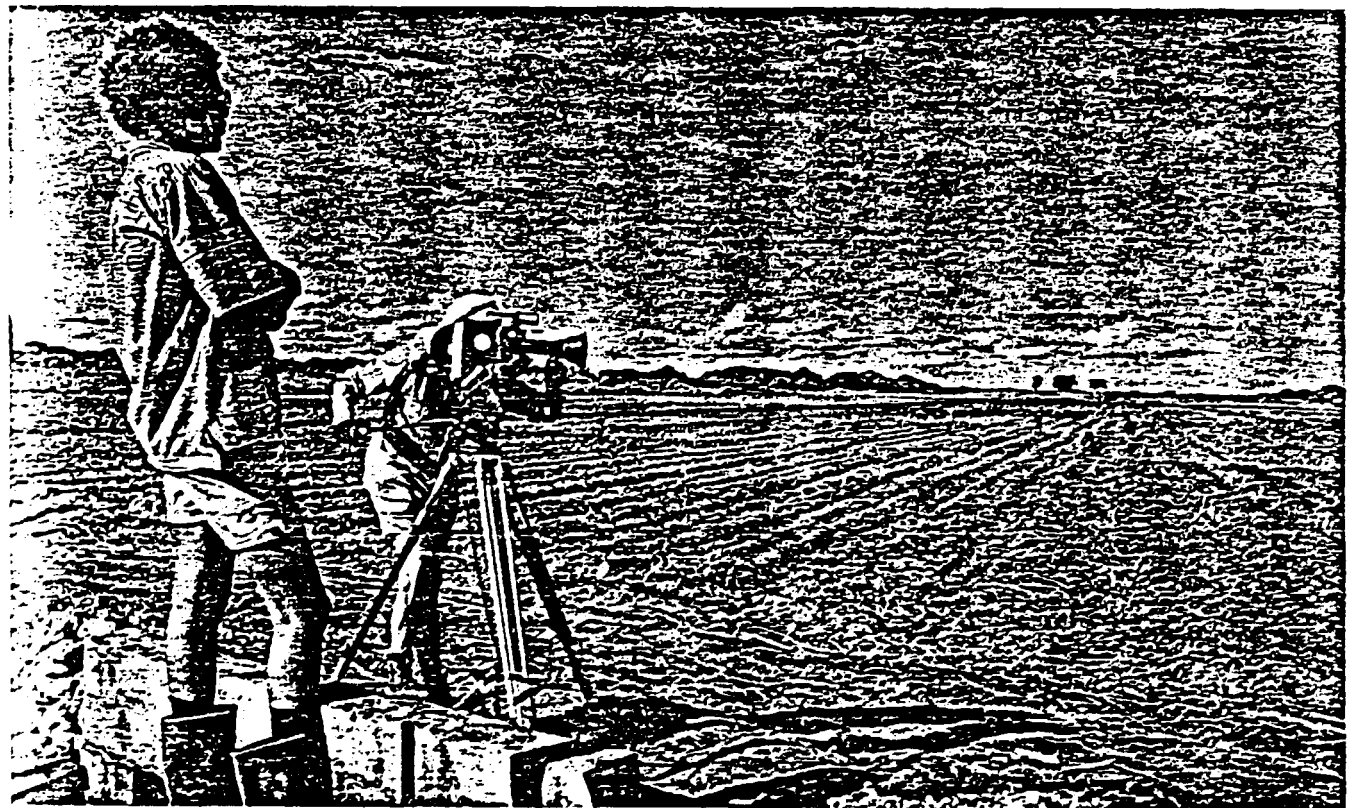

3. MOBILE TRAINING + VIDEO
PRODUCTION UNIT.

3.

MOBILE TRAINING UNITS PLUS VIDEO PRODUCTION UNIT

This is a specially fitted-out vehicle (Landrover or other make) similar to option no 2, with the addition of 16mm film re-winder and splicer floodlight and a full suite of high quality U-format video equipment for shooting, editing and telecine recording.

This option provides two functions :

1. As a mobile a/v presentation unit; and
2. As a mobile video unit, which facilitates
 - a) Video recording of local conditions.
 - b) Recording & playback of trainees performance.
 - c) On-the-spot production of training films to local requirements.

Power is provided by a power take-off unit.

Supplier : British Films Ltd.

Cost : £ 27,950 with high quality full video equipment,

(approx £ 17,950 without high quality full video equipment)

**BRITISH
FILMS
LIMITED**

OUR REF: REL/CG/2048/83

Biograph House
251 Vauxhall Bridge Road
London SW1V 1EJ

Telephone 01-828 7965
Telex 947165

Mrs. Shirley A. Parfitt ATD, FSIAD,
Barley Mow Workspace,
10, Barley Mow Passage,
London W4 4PH.

SPECIFICATION

UNIDO PROJECT - EGYPT

MOBILE CINEMA AND VIDEO UNIT

One Land Rover: Long wheel base station wagon, Series III
4 cylinder petrol engine
Less middle bench and rear seats

LEFT HAND DRIVE COLOUR: BRONZE GREEN

Fitted with: Driver and passenger seats
Centre Power take-off
Engine speed governor
Governor position stop
Accelerator retaining bracket
Oil cooler equipment
Oil temperature gauge
Oil pressure gauge
Water thermometer
Electrical suppression for engine
Laminated windscreen glass
750 x 16 tyre equipment
Windscreen washers
Light fitted under bonnet
Spare wheel and carrier mounted on
de luxe bonnet with lock
- additional carrier on rear door
10 gallon (45 litre) additional fuel
tank with change-over tap beneath
driver's seat, change-over switch
for fuel gauge in dash panel.
Giving a total capacity of 26 gallons
(118 litres).

.../...



British Films Limited
Registered in England no. 1657159

Registered office as above

Directors
A. Shand-Kydd
J. Sheehan
R. Langman

Corrugated alloy platform assembly fitted to roof of vehicles.
Four rung steel ladder fitted to rear, to give access to roof platform.
Loudspeaker mountings fore and aft of roof.
Brackets for loudspeaker and screen mountings.

Built-in loudspeaker sockets.
Built-in cable drum for power supply.
Equipment stowage cabinet with access from side doors.
Stowage facilities for ancillary equipment.

Self-contained power supply provided by self-regulating alternator belt driven from centre power take-off unit on engine, producing 3 KVA 230 volt 50 cycles AC.
Electrical wiring in flexible conduit.
Electrical control panel with frequency meter, volt meter and voltage control regulator.

AUDIO-VISUAL EQUIPMENT

PROJECTION SYSTEM:

- 1 ~~Re-entrant~~ Bell and Howell Model 2592 16mm projector with optical sound replay, built-in amplifier, speaker in side cover, with 51mm lens, matching unit and 1600ft spool. Power supply: Multi-voltage.
- 1 Zoom lens 35-65mm f1.6
- 1 High level demountable projector stand
- 1 Screen, matt white 8' x 6' (240cm x 180cm) for mounting on vehicle.
- 1 Screen mounting assembly
- 1 Indoor screen

AUDIO SYSTEM:

- 2 Re-entrant loudspeakers 30 watt output each
- 1 Omni-directional microphone with floor stand

ANCILLARY ITEMS:

- 1 16mm film rewinder
- 1 16mm film splicer
- 1 150 watt floodlight and stand
- 1 Mains distribution box
- 1 Set of cables for all systems

VIDEO SYSTEM:

- 1 JVC Model CP 5060 ET U Format Pal/Secam video cassette - recorder/play - still picture and full electronic remote control facility.
- 1 JVC Model RM88U Microprocessor based electronic editing control unit. Variable speed, tape shuttle search control forward/reverse.
- 1 JVC Portable professional video camera Model KY1900E110. Auto beam control. Built-in genlock, EBU colour bar generator - fully portable comprising:-

KY1900E camera head
H2 2100E 10:1 servo zoom lens
VF 1900E 1.5" viewfinder
AAC 19E AC Power adapter/charger
DC-C 19E NIC cad battery pack
VC 511/2 VTR cable whether (VTR 10 pin or 14 pin connector CB 1900V carrying case)

- 1 16mm telecine attachment to HZ2100E - zoom lens

Kodak carousel SAV 2010 slide projector complete with carrying case 150mm & 250mm lens slide tray, remote control and one lamp.

Bell and Howell overhead projector Model 1702K.
A4 format, lamp height adjuster lamp change mechanism, high quality (3.5, 317mm lens, 24V. 250 watt.
A1/223 lamps - Complete with:

Roll feed cassette
Dust cover
Cellofilm roll
3 acetate packs

- 1 Barco CS66 26" monitor

SPARES AND ACCESSORIES:16mm projector

- 3 1600ft spools
- 1 Integrated circuit for motor
- 1 Amplifier board
- 1 Main drive belt
- 6 Emm projector lamps
- 6 Exciter lamps
- 3 Sets of fuses
- 2 Gate brushes
- 1 Bottle of oil

Alternator:

- 1 Pair matched drive belts
- 1 Set AC brushes

Vehicle:

- 1 Set of engine belts
- 1 Set of plugs
- 1 Set of contact breaker points
- 1 Oil filter

Miscellaneous:

- 2 Speaker diaphragms
- 1 Inspection lamp, 12 volt with lead
- 1 Fire extinguisher
- 2 Cords with hook fitted for raising screen
- 2 Sets of spare lamp bulbs for inspection, interior and floodlight
- 1 Soldering iron
- 1 Reel of solder

Tools:

- 1 Set of Landrover vehicle tools
- 1 Set Allen keys
- 1 Pair pliers
- 1 Set BA spanners
- 1 Pair side cutters

Manuals:

- 1 Filmobile set of operating instructions
- 1 Landrover vehicle manual
- 1 Bell and Howell service manual
- 1 Set of AV equipment instruction manuals
- 1 JVC equipment manuals

OUR REF: REL/CG/2048/83

- 5 -

19th October, 1983.

PRICE FOR ONE MOBILE CINEMA AND VIDEO UNIT IN ACCORDANCE WITH
THIS SPECIFICATION:

F.O.B. U.K. PORT STERLING POUNDS £ 27,950.00

VALIDITY: OF THIS OFFER IS 60 DAYS

DELIVERY: APPROXIMATELY 12 WEEKS FROM RECEIPT OF
LETTER OF CREDIT.

PAYMENT: BY AN IRREVOCABLE LETTER OF CREDIT VALID FOR
A PERIOD OF 26 WEEKS DRAWN ON AND CONFIRMED BY
A LONDON BANK, CONFIRMING FEE AT YOUR CHARGE,
REQUIRING PAYMENT AGAINST PRESENTATION OF
SHIPPING DOCUMENTS AND ALLOWING FOR PART
PAYMENT AGAINST PART SHIPMENT AND ALLOWING
IF NECESSARY TRANSHIPMENT

OR

UNITED NATION AGENCY STANDARD TERMS.

R.E. LANGMAN
DIRECTOR

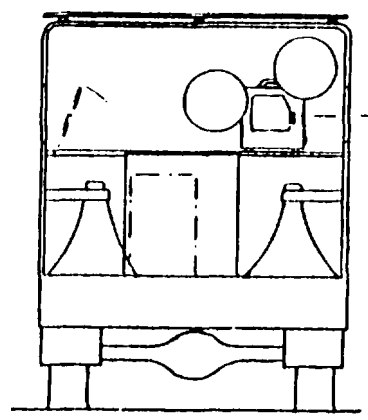
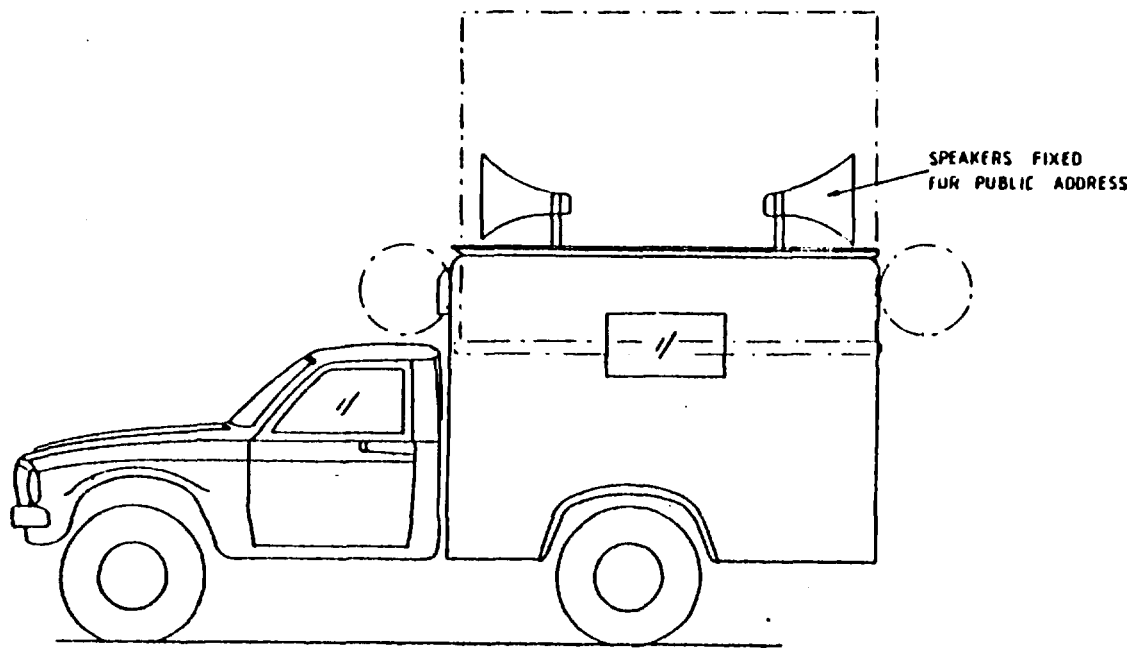
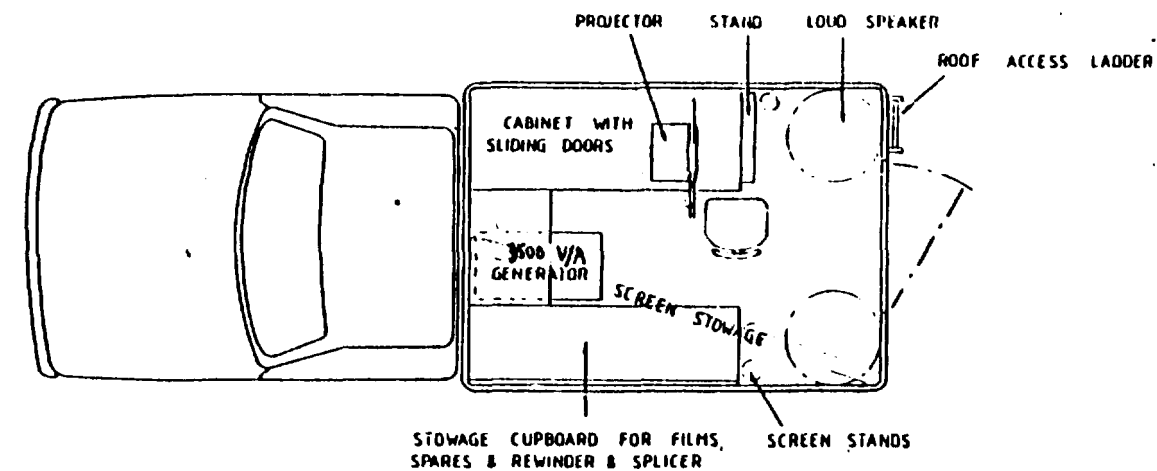

INTERIOR VIEW FROM REAR

FILMOBILE BASED ON A TOYOTA HI-LUX 4 WD

DRAWING No 0188

4. a) MOBILE CLASSROOM + VIDEO PRODUCTION
b) MOBILE CLASSROOM / WORKSHOP

4. (a)

MOBILE CLASSROOM PLUS VIDEO PRODUCTION UNIT

- a) This version is a 25-seater cinema and lecture unit, plus video production facilities, in a 40 foot long trailer with traction unit.
This specification may be varied; e.g.
- b) As a mobile classroom only, excluding the video equipment.
- c) As a 40 foot trailer fitted as a classroom, but excluding the traction unit.
- d) The trailer can also be fitted out as a workshop.

Supplier : British Films Ltd.
Biograph House, 251 Vauxhall Bridge Road,
London SW1V 1EJ
Telephone : 01-828 7965
Telex : 947165

Price : a) Complete Mobile Classroom plus video equipment
£ 64,950

4 (b)

MOBILE CLASSROOM/WORKSHOPS

As above, but without video equipment.

Price £54,950 approx.

This trailer with or without traction unit can also be fitted out as a mobile workshop to client's specifications.

**BRITISH
FILMS
LIMITED**

OUR.REF: REL/CG/2049/83

21st October, 1983.

Biograph House
251 Vauxhall Bridge Road
London SW1V 1EJ
Telephone 01-828 7965
Telex 947165

Mrs. Shirley A. Parfitt ATD, FSIAD,
Barley Mow Workspace,
10, Barley Mow Passage,
London, W4 4PH.

SPECIFICATION

UNIDO PROJECT - EGYPT

MOBILE TRAILER CLASSROOM

LECTURE, CINEMA & VIDEO UNIT

On Bedford Tractor Unit Model TL1630
As per manufacturer's specification

LEFT HAND DRIVE

COLOUR: TO BE AGREED

Complete with swan neck trailer 40' long fitted all aluminium body
with main lockable entrance door and one emergency door.

Air-conditioner - 9,000 btu.

Petrol electric generator 6 KVA in separate compartment.

Front 8 feet of floor raised 1 foot for lecturer and supply of table.

25 seat capacity for students together with flap type tables for
writing notes.

Rear of body to have storage compartment for equipment and projection
platform for 16mm and slide projector.

Supply of 4 foot screen over generator compartment complete with two
wall mounted loud speakers.

AUDIO-VISUAL EQUIPMENT

PROJECTION SYSTEM:

- 1 Bell and Howell Model 2592 16mm projector with optical sound
replay, built-in amplifier, speaker in side cover, with 51mm
lens, matching unit and 1600ft spool. Power supply:
Multi-voltage.

.../...

PROJECTION SYSTEM Cont.

- 1 Zoom lens 35-65mm fl.6
- 1 High level demountable projector stand
- 1 Screen, matt white 8' x 6' (240cm x 180cm) for mounting on vehicle
- 1 Screen mounting assembly
- 1 Indoor screen

AUDIO SYSTEM:

- 2 Re-entrant loudspeakers 30 watt output each
- 1 Omni-directional microphone with floor stand

ANCILLARY ITEMS:

- 1 16mm film rewinder
- 1 16mm film splicer
- 1 150 watt floodlight and stand
- 1 Mains distribution box
- 1 Set of cables for all systems

VIDEO SYSTEM:

- 1 JVC Model CP 5060 ET U Format Pal/Secam video cassette - recorder/play - still picture and full electronic remote control facility.
- 1 JVC Model RM88U Microprocessor based electronic editing control unit. Variable speed, tape shuttle search control forward /reverse.
- 1 JVC portable professional video camera Model KY1900E110. Auto beam control. Built-in genlock, EBU colour bar generator - fully portable comprising:-

- KY1900E camera head
- H2 2100E 10:1 servo zoom lens
- VF 1900E 1.5" viewfinder
- AAC 19E AC power adapter/charger
- DC-C 19E NIC cad battery pack
- VC 511/2 VTR cable whether (VTR 10 pin or 14 pin connector
- CB 1900V carrying case)

- 1 16mm telecine attachment to HZ2100E - zoom lens

Kodak carousel SAV 2010 slide projector complete with carrying case
150mm & 250mm lens slide tray, remote control and one lamp.

Bell and Howell overhead projector Model 1702K.
A4 format, lamp height adjuster lamp change mechanism, high quality
(3.5, 317mm lens, 24V. 250 watt).
A1/223 lamps - complete with:

Roll feed cassette
Dust cover
Cellofilm roll
3 Acetate packs

1 Barco CS66 26" monitor

SPARES AND ACCESSORIES:

16mm projector

3 1600ft spools
1 Integrated circuit for motor
1 Amplifier board
1 Main drive belt
6 Emm projector lamps
6 Exciter lamps
3 Sets of fuses
2 Gate brushes
1 Bottle of oil

Vehicle:

1 Set of engine belts
1 Set of plugs
1 Set of contact breaker points
1 Oil filter

Miscellaneous:

2 Speaker diaphragms
1 Inspection lamp, 12 volt with lead
1 Fire extinguisher
2 Cords with hook fitted for raising screen
2 Sets of spare lamp bulbs for inspection, interior and floodlight
1 Soldering iron
1 Reel of solder

Tools:

1 Set of Bedford vehicle tools
1 Set Allen keys
1 Pair pliers
1 Set BA spanners
1 Pair side cutters

21st October, 1983.

Manuals:

- 1 Bedford vehicle manual
- 1 Bell and Howell service manual
- 1 Set of AV equipment instruction manuals
- 1 JVC equipment manuals

PRICE FOR ONE COMPLETE MOBILE TRAILER CLASSROOM IN ACCORDANCE WITH THIS SPECIFICATION:

FOB UK PORT

STERLING POUNDS

£64,950

VALIDITY:

THIS OFFER REMAINS VALID FOR 60 DAYS.

DELIVERY:

APPROXIMATELY 26 WEEKS FROM RECEIPT OF OFFICIAL ORDER AND LETTER OF CREDIT.

PAYMENT TERMS:

BY AN IRREVOCABLE LETTER OF CREDIT VALID FOR A PERIOD OF 32 WEEKS DRAWN ON AND CONFIRMED BY A LONDON BANK. CONFIRMING FEE AT YOUR CHARGE REQUIRING DOWN PAYMENT OF 50% WITH ORDER AND BALANCE AGAINST PRESENTATION OF SHIPPING DOCUMENTS AND ALLOWING IF NECESSARY TRANSHIPMENT

OR

UNITED NATIONS AGENCY STANDARD TERMS WITH 50% DEPOSIT WITH ORDER AND BALANCE WITHIN 14 DAYS OF SHIPMENT.

R.E. LANGMAN
DIRECTOR

DRG. No.

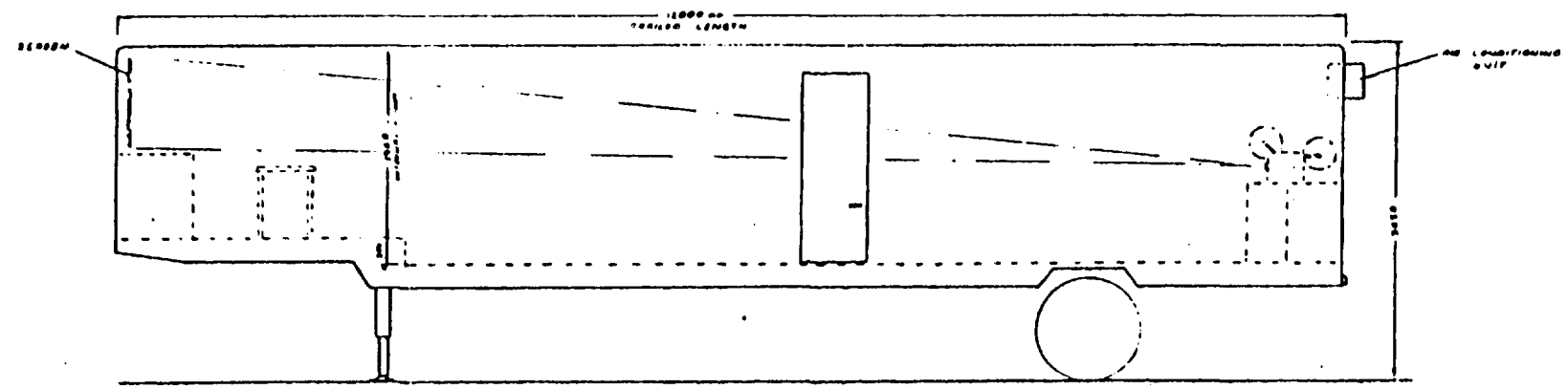
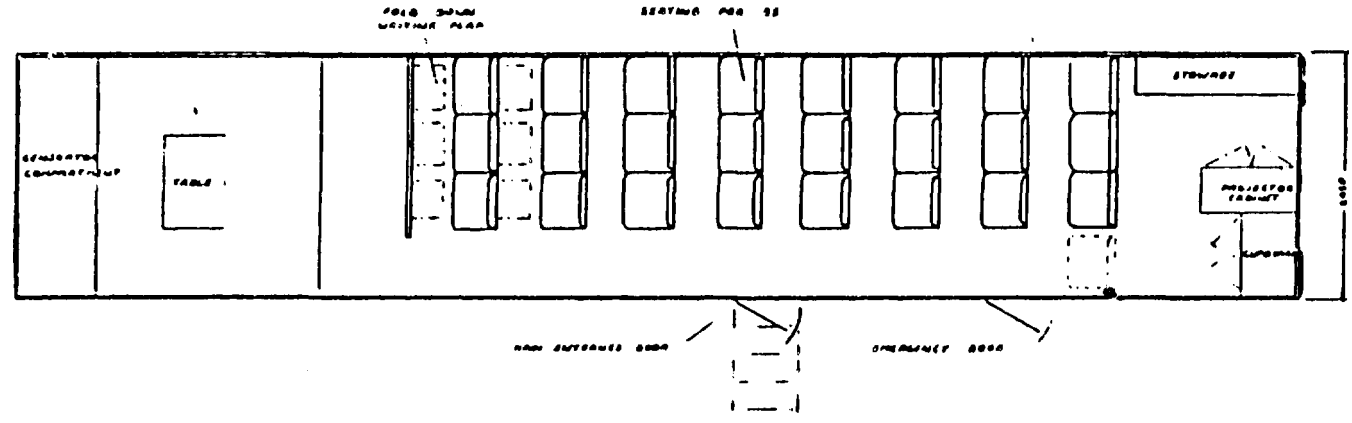

MOBILE LECTURE THEATRE

BRITISH FILMS LTD.
LONDON

5. MOVABLE PREFABRICATED
CLASSROOMS / WORKSHOPS

5. PREFABRICATED MOVABLE TRAINING UNITS

Prefabricated buildings supplied in modules and mounted on a chassis with retractable supports for stability.

These can be fitted out to any specification as classrooms or workshops, i.e. welding, pipe-laying, automotive mechanics, automotive electrics etc.

Supplier : Philip Harris International Ltd.

Lynn Lane, Shenstone, Staffordshire, WS14 0EE,
U.K.

Telephone (0543) 480077. Telex 336498

P.S.

The suppliers are submitting a tender to Government
Organization for Industry, ^{Egypt} for six workshop at the present
time, Dec. 1983

Prefabricated Movable Training Units

VOCATIONAL EDUCATION & TRAINING

PHILIP HARRIS

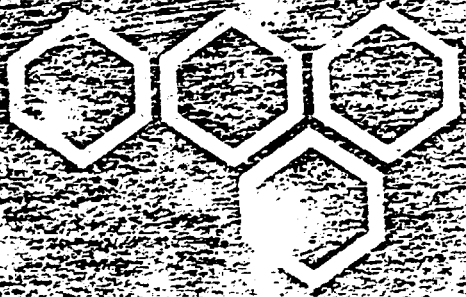

Mobile
Training
Station

Prefabricated
Buildings

Prefabricated Mobile Training Facilities

- Provides development of Mobile Training facilities to rural areas.
- Portable modular concept gives extreme flexibility of design.
- Encourages maximum effective utilisation of available teaching staff.
- Readily adaptable to evolving technological needs.
- Allows rapid development from original design assessment to operational unit.
- May be installed in normally difficult locations, using unskilled labour.
- Full consultancy back-up service at all stages of implementation.

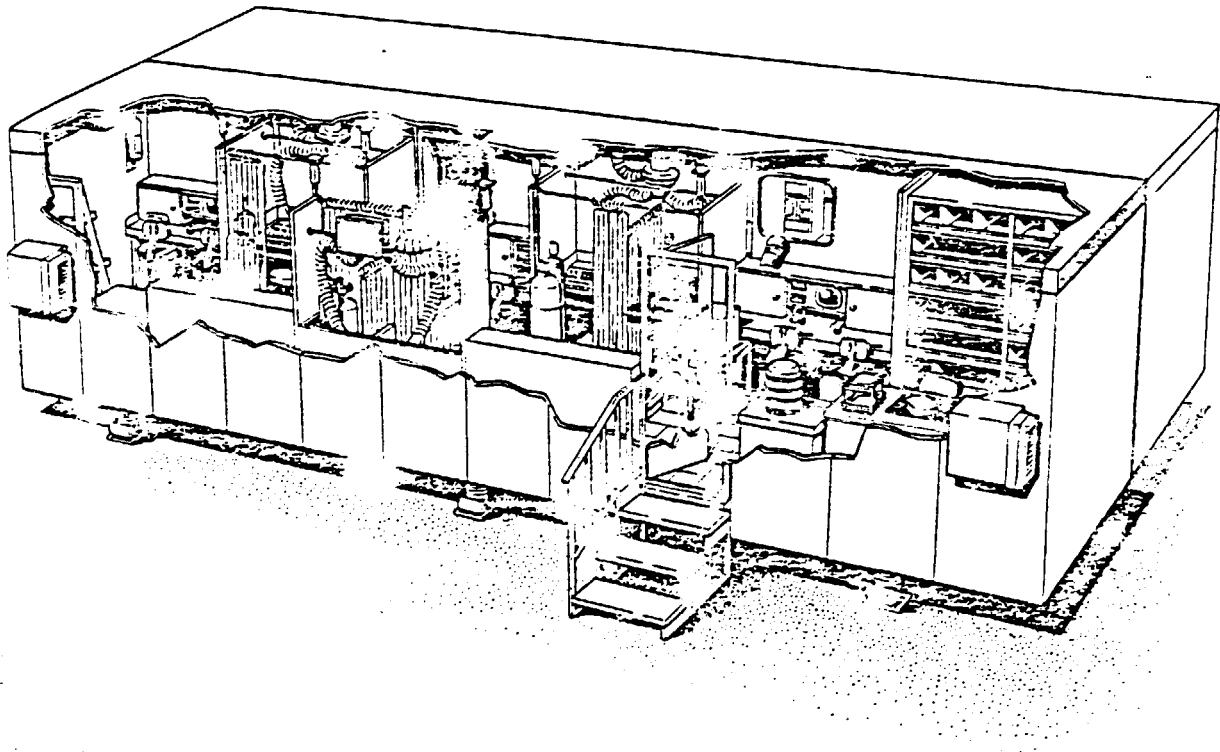

Training

Prefabricated Buildings

The primary requirement for effective Vocational Training is the provision of fully equipped accommodation for the training centres. From the nature of the equipment, machinery etc. offered in this catalogue, it can be seen that for the types of teaching programme involved properly implemented and carried out, adequate workshops, lecture rooms and possibly student accommodation are of great importance.

To meet these requirements and provide a satisfactory solution Philip Harris (International) Limited offer a modular system of mobile and semi-mobile teaching facilities which allow any kind of Vocational Technology training programme to be established without the need for permanent building construction of the traditional type. The system is based upon a range of prefabricated building and trailer transported mobile units of flexible design which may be assembled in the form of machine workshops, lecture theatres, classrooms, offices etc. and may be equipped with whatever complement of equipment, furniture or other fittings and facilities that the customer requires.

