



TOGETHER
for a sustainable future

OCCASION

This publication has been made available to the public on the occasion of the 50th anniversary of the United Nations Industrial Development Organisation.



TOGETHER
for a sustainable future

DISCLAIMER

This document has been produced without formal United Nations editing. The designations employed and the presentation of the material in this document do not imply the expression of any opinion whatsoever on the part of the Secretariat of the United Nations Industrial Development Organization (UNIDO) concerning the legal status of any country, territory, city or area or of its authorities, or concerning the delimitation of its frontiers or boundaries, or its economic system or degree of development. Designations such as “developed”, “industrialized” and “developing” are intended for statistical convenience and do not necessarily express a judgment about the stage reached by a particular country or area in the development process. Mention of firm names or commercial products does not constitute an endorsement by UNIDO.

FAIR USE POLICY

Any part of this publication may be quoted and referenced for educational and research purposes without additional permission from UNIDO. However, those who make use of quoting and referencing this publication are requested to follow the Fair Use Policy of giving due credit to UNIDO.

CONTACT

Please contact publications@unido.org for further information concerning UNIDO publications.

For more information about UNIDO, please visit us at www.unido.org

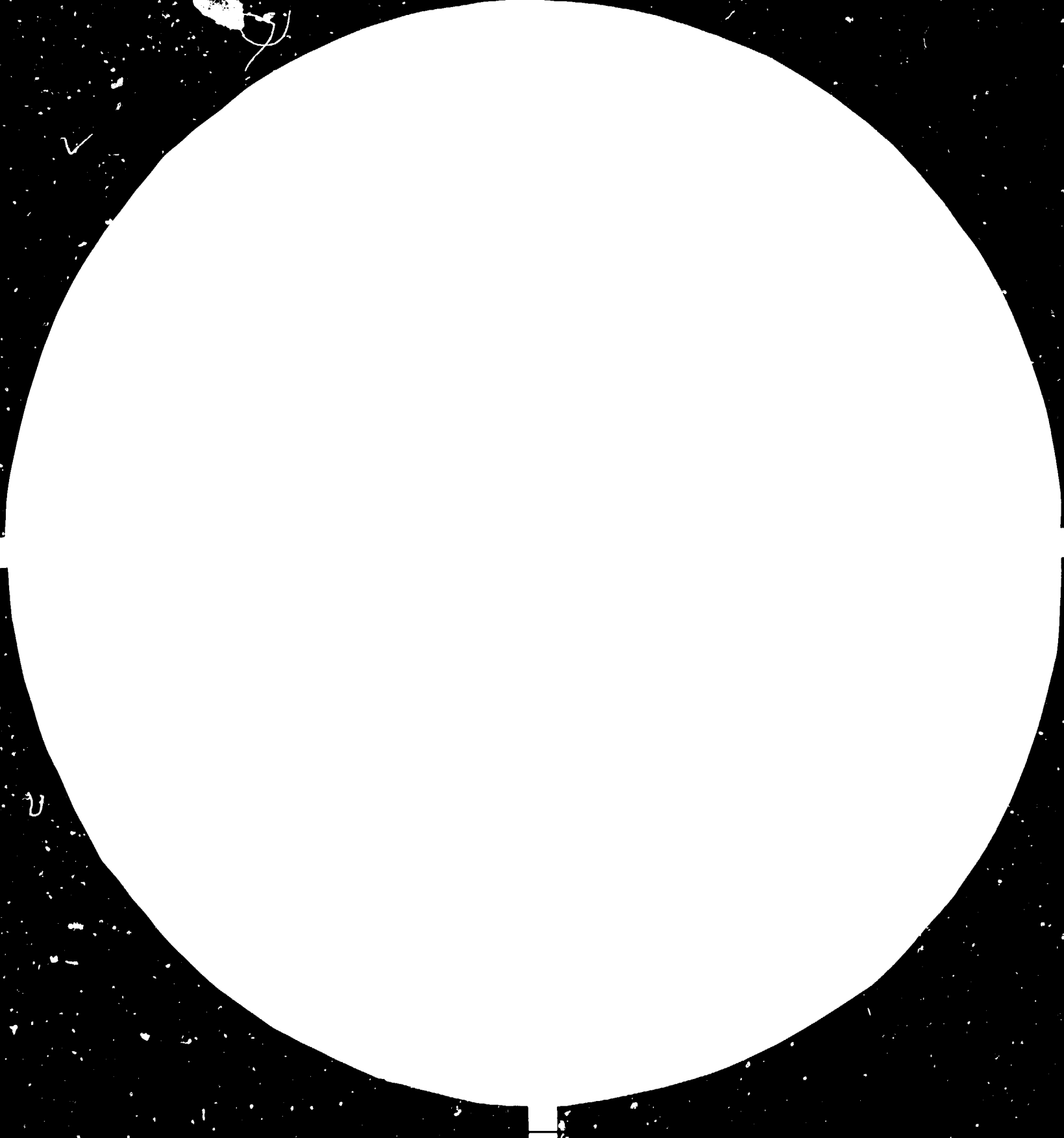



3.2

3.6

4



MICROCOPY RESOLUTION TEST CHART

NATIONAL BUREAU OF STANDARDS
STANDARD REFERENCE MATERIAL 1010
FALL 1963 EDITION TEST CHART NO. 2

Interim Report : SEKA - Turkey

13355

English

INTERIM REPORT

Turkey. Paper and Board Coating.

SEKA - Turkey .

DP/TUR/81/018/11-06/32.1.E

Trevor W. R. Dean

Expert in Paper and Paperboard Coating

January 1983

United Nations Industrial Development Organization

VIENNA

Interim Report : SEKA - Turkey

CONTENTS

<u>Section</u>	<u>Page</u>
Introduction	3
1. Izmit Mill - Initial Period	7
2. Dalaman Mill - Work on Improving Base Papers/Boards	9
3. Status of Coating Equipment at Dalaman	13
4. Laboratory Work	15
5. Quality Improvements	17
6. Local China Clay	20
7. Meetings with Customers/General Quality Comments	23
8. Training/Personnel	27
9. Visit to Afyon Mill	30
10. Izmit Mill - Second Period	32
11. Fellowships	35
12. General	37
13. Conclusions/Recommendations	38
Postscript	41

<u>Appendix - Number/Description(*)</u>	<u>Page (Appendix)</u>
1. Izmit - Training/Suggested Research Programme	1
2. Report of the Quality Committee	4
3. Composition of the Quality Committee	5
4. Coating Mix Feed System	6
5. Relative Humidity Graphs	7
6. Dalaman Clay Preparation Plant	8
7. Ream Packing	10

(*) Appendix printed in different typeface.

Interim Report : SEKA - Turkey

INTRODUCTION

This report describes the mission carried out by Trevor W R Dean within the SEKA PULP AND PAPER MILLS, Turkey, during the period 24.10.1983 - 23.12.1983 according to the following schedule:

24.10.1983	Travel to UNIDO, Vienna
25.10.1983	Briefing in UNIDO offices
26.10.1983	Travel to Ankara via Istanbul
27.10.1983	Briefing in UNDP offices
28.10.1983	Travel to Izmit

AT IZMIT MILL

04.11.1983	Travel to Dalaman
------------	-------------------

AT DALAMAN MILL

08.12.1983	Travel to Afyon
09.12.1983	At Afyon mill
10.12.1983	Travel to Izmit

AT IZMIT MILL

18.12.1983	Travel to Ankara
19.12.1983	De-briefing in UNDP offices
21.12.1983	Travel to Vienna via Istanbul
22.12.1983	De-briefing in UNIDO offices
23.12.1983	Travel to England

The job specification for the mission was originally published as follows:

"Plan research on coating materials and recommend which equipment should be bought."

Interim Report : SEKA - Turkey

However, this specification was subsequently modified at the request of SEKA to include assistance with the production of coated papers at the Dalaman Mill, with particular importance given to the development of suitable coating bases. On arrival in Izmit, a detailed plan of action was drawn up in consultation with Mr Ziya Yelen and Mr Ayhan Mengi and submitted (by telex via UNDP Office, Ankara) to Dr M Judt, UNIDO Vienna, for approval. In summary, this plan included the following objectives:

1. Carry out an intensive theoretical training course for the Research Team at Izmit.
2. Advise on testing/research equipment required for the the Research Centre.
3. Assess the coating facilities at Dalaman and advise on any modifications required.
4. Draw up training programmes for Dalaman personnel and involve SEKA Engineers in the lecturing wherever possible. Translate all notes into Turkish.
5. Assist the Dalaman Production Manager (Feridun Yalcinkaya) with an intensive programme to improve all base papers and boards - depending upon what fibre furnishes were available at Dalaman.
6. Optimise the coating process.
7. Monitor all trials carried out.
8. Promote and supervise an on-going development programme to utilise local coating pigments, binders and additives.
9. Assist, wherever possible, with the day-to-day trouble-shooting throughout the mill and remain on call 24 hours per day, 7 days per week throughout the mission.
10. Wherever possible, to encourage liaison between production, instrumentation and technical departments.
11. Assist with the drawing up of a relevant research programme for the Research Centre with special emphasis on the utilisation of local raw materials.

Interim Report : SEKA - Turkey

12. Assess the future training needs in the areas of paper/board coating and base production.

At the special request of Mr G Narasimhan of the UNDP Office, Ankara, the Expert was to look out for suitable candidates for fellowships, for example, those SEKA Technical Staff Members who would benefit from a study tour/training course in the United Kingdom.

Because of the change in job specification, it was decided to issue a weekly report in telex form, copied to UNDP Offices, Ankara, Mr May/Dr Judt UNIDO, Vienna and Mr Ziya Yelen. The objective was to give the controlling bodies the opportunity to revise the work programme in the light of new information arising. Also, in view of this weekly reporting procedure, the main body of this report merely summarises the various activities of the Expert while on mission and attempts to assess the results obtained. The final SECTION of the main report contains a list of recommendations embracing all aspects of the mission. The report is furnished with a number of APPENDICES.

The Expert recommends that the following persons shall be included on the circulation list for this report:

IZMIT MILL

Mr Salahattin Yalinpala
Mr Ismit Genc

Miss Ferhun Taptik

General Director
Assistant Director,
Technical
Production Director

Interim Report : SEKA - Turkey

DALAMAN MILL

Mr Hilmi Ogeer
Mr A Kadir Karakuzulu

General Manager
Assistant Manager,
(Technical)
Coating Manager

Mr Suleyman Sahin

AFYON MILL

Mr Renzi Aksu

General Manager

(The above list is in addition to the normal distribution list of
UNIDO reports.)

Interim Report : SEKA - Turkey

1. IZMIT MILL - INITIAL PERIOD (29.10.1983-04.11.1983)

The work carried out during this period can conveniently be divided into two parts:

- Part 1.** Training the Research Group based at the Izmit Mill in basic coating theory.
- Part 2.** Preparing a suitable coating research programme for the Research Group.

The selection of the laboratory equipment was deferred until the Expert had had an opportunity of seeing the Dalaman laboratory facilities and equipment. It was considered to be important that the laboratory equipment chosen for the Research Centre was capable of simulating the production conditions at Dalaman as closely as possible and that all testing equipment should be identical to that in the Dalaman laboratory.

At the end of the programme, a meeting was held with Miss Ferhan Taptik (SEKA Production Director) to discuss the production problems of Dalaman. Miss Taptik arranged to send **Mr Kadir Cobanuglu** from her department down to Dalaman, to work closely with the Expert for the duration of the mission there. The objective was to ensure that any recommendations made were carried out as speedily as possible. In addition, Mr Ziya Yelen agreed to send two members of the Research Team down to Dalaman for a short period (**Mr Ayham Mengi**, Research Manager and **Ms Besime Eryener**, Chief of Fundamental Research) These actions

Interim Report : SEKA - Turkey

were welcomed by the Expert and, in his opinion, contributed to the smooth running of the mission. The Expert was also to be accompanied by the UNDP Representative, **Mr Ahmet Dogukan**, who would act as a "secretariat" to the mission and supervise the translation of any notes.

A summary of both the **training programme** and the **research programme** can be found in **APPENDIX 1** of this report.

NOTE

During this stay at the Izmit Mill, the Expert visited several of the Paper Mills on the site and noticed that the standard pulp stacking left much to be desired. It is strongly recommended that the Izmit Mill Site pays particular attention to the storage of its pulp bales (especially the imported pulps) since irregular stacking leads to rapid deterioration of a valuable raw material.

2. DALAMAN MILL - WORK ON IMPROVING BASE PAPERS/BOARDS

On studying the situation at the Dalaman Mill, it was very apparent that immediate work had to be carried out to reduce the numbers of physical defects in the paper/board as well as improving its level and uniformity. It was particularly important to solve these problems very quickly because the manufacturer of the coating machine (Messrs. Voith of Heidenheim, West Germany) was due to send a team to carry out a formal test run beginning on or about 23.11.1983. A previous attempt to carry out the test run had been abandoned owing to poor runnability of both base papers and boards.

The situation was somewhat complicated by the Mill having been shut for four weeks immediately prior to the arrival of the Expert. For the first week of the mission the Kamyrdigester was still undergoing major repairs and the paper/board making lines were operating on dry pulp. During the shut the paper machine had been fitted with a complete foil table (in place of the table rolls).

The problems on the paper machine were tackled in the following steps:

Interim Report : SEKA - Turkey

- * The deckle straps on the paper machine were adjusted to minimise the turbulence on the wire.
- * The short fibre content of the furnish was increased to close up the formation. It proved difficult to increase the short fibre content much above 30% since the only short fibre available at the time was Afyon straw pulp; this was extremely variable in quality especially in respect of unbeaten Schopper Riegler. Later in the mission, 50 tonnes of reed pulp (also from Afyon) was made available. This enabled the short fibre content to be increased to 40%.
- * The dry line was straightened and the final moisture content of the paper progressively increased from 4% to 5.5%.
- * Speed and direction of the evener rolls in the flow box were adjusted to optimise the formation.
- * Machine trials were carried out using a retention aid (a locally-produced cationic starch) to improve retention of both short fibres (fines) and filler. The concern was that, in order to achieve a 10 - 12% final ash, the amount of filler in the flow box rose to above 40%. During the trial, more filler was carried on the wire but the test results were not startling. It may be advantageous to increase the addition of cationic starch from 0.5% on fibre to 0.8% in future trials.
- * At the first wire change, the flow box and approach system was thoroughly cleaned out using hot caustic soda solution. This dramatically reduced the incidence of slime holes in the sheet and the runnability of the coating machine improved. This should be a regular procedure and, together with the addition of a suitable slime control agent, a much better base sheet can be produced.
- * The machine crews were encouraged to improve paper quality by continuously checking for holes, creases and general bad level.

At the same time, the quality standard of the board products was improved by the following programme:

- * The water spray before the Yankee was re-installed so that curl could be controlled.

Interim Report : SEKA - Turkey

- * The newly re-ground machine calender stack was brought into operation.
- * The direction of the metering bar was changed to give a more even coating.
- * The temperatures of the two unfelted cylinders immediately after the metering bar coating unit were reduced to minimise picking.
- * The final moisture content was raised to 5.5%.

In order to monitor the results of all the changes made, a Quality Committee was set up. This Committee was made up of representatives from the Production Departments (both paper/board and coating), the Laboratory and the people seconded from the Izmit Mill. Prior to the beginning of the Test Run, this Committee issued a summary Report of the progress made (see **APPENDICES 2 and 3** for details).

The amount of quality improvement made during the first 18 days of the mission (due mainly to the cooperation of the Dalaman personnel) can be measured by the fact that the Test Runs were made without major runnability problems. It was proved possible to run the coating machine at its maximum speed (640 metres/minute) for long periods of time with 60 g/m² base paper and at 300 metres/minute for board.

The situation by the end of the mission was that an optimum level of quality for paper and board had been reached in view of hardware limitations. These were:

Interim Report : SEKA - Turkey

- * The paper machine has no dandy roll and the poor top surface of the sheet reflects this unsatisfactory situation. The Expert had a meeting with the Turkish agent who claimed that a complete new unit was on order from his French principals.
- * The second press of the paper machine had been fitted with a very unsatisfactory Italian felt which was giving excessive levels of vibration at speeds above 300 metres/minute.
- * The paper machine size press is almost impossible to run with its present configuration. An extra roll (a bow roll possibly) is required to spread the paper in the approach run to the nip.
- * The paper machine calenders are not operated at the present time and it is recommended that two of the rolls are removed to simplify the stack.
- * The on-machine moisture/grammage meters on both paper and board machines were not operating at the start of the mission. During the final part of the mission, a specialist from Lippke (the suppliers) was on site re-installing the equipment. The continuous operation of these units will enable the machine operators control the final moisture contents of all papers and boards as well as check the grammage profile.
- * The temperature of the Yankee on the board machine is low (90°C maximum). The cause for this should be checked.
- * A damping system would be useful immediately prior to the reel-up of each machine.

3. STATUS OF COATING EQUIPMENT AT DALAMAN

The general impression of the equipment at Dalaman is that it is a very large installation for a mill with no previous coating experience. However, it is well set out and, with a only a few problem areas remaining, is working surprisingly well. The main difficulty is experienced with the flying splice due, it appears, to a synchronization problem. The Voith specialists were still working on this section of the coater when the Expert left site.

The coating machine has a very long paper run before the coating head and this imposes very tight limits on base uniformity and level. It is, therefore, even more important that the base from the paper/board making section is of good level otherwise creasing is inevitable. The innovation carried out by Mr Suleyman Sahin which involves wrapping the rolls in this lead-in section with tape has certainly eased the problem of creasing and edge flutter but the tape is not very permanent and is prone to lifting; this could give problems with light-weight base sheets.

A second spray damping unit was installed on the machine, but due to the extended Test Runs (owing to the problem with flying splice) the equipment was not tried. The idea is to effect further curl correction on one-sided coated grades. At the time of the mission, all papers and Bristols were coated on both sides to overcome the tendency to curl, a practice which is most unsatisfactory. The second damping unit may help the operators control the curl to an acceptable level.

Interim Report : SEKA - Turkey

The installation of a second feed tank to the coating head was discussed. This tank would be fitted with a vibrating screen to take out fibres and debris returning from the blade. The tendency is for the in-line filters to block very quickly, and since these have manually operated back-washing facilities, they demand constant attention from the operators. The vibrating screen should help to reduce this build-up of debris in the filter unit. The tank will also help when changing coating formulation (say from gravure to offset formulations) as it enables a discreet change to be made (see **APPENDIX 4** for sketch).

4. LABORATORY WORK

During the mission, a continuous programme of laboratory work was carried out. This included:

- * Designing coating mix formulations for gravure and offset litho papers and alternative formulations for the board grades.
- * Evaluating samples of potential coating raw materials produced in Turkey, including:

- barium sulphate
- satin white
- casein
- starch
- calcium carbonate
- viscosity controller
- C.M.C.
- dispersing agent
- synthetic latex

The laboratory should be encouraged to continue this programme with the objective of reducing the dependence of the Dalaman Mill on imported materials.

- * Evaluations of retention trials carried out using locally produced cationic starch.
- * Evaluation of coating clay produced at Dalaman Mill using pre-ground clay as a feed-stock.
- * Carrying out checks on flow box fibre and clay contents at regular intervals to try to establish a reason for the drifting of grammage on the paper machine. As a result of this work, the problem was traced to a defective consistency controller.
- * Carrying out regular profile checks for

- grammage
- caliper
- moisture
- ash
- porosity
- sizing

This work was invaluable when quality improvements were being attempted, bearing in mind that the extra load put on the laboratory was considerable.

Interim Report : SEKA - Turkey

- * Assessing loss of raw materials to drain. Analysing results obtained by the laboratory during the past eighteen months indicated that, on some days, **as much as 10% of the total paper and board production finds its way to the drain.**

The Laboratory is under the very capable control of Mrs Gurcihan Beslek and, in particular, the routine testing is well organized. It is a pity that the results are largely ignored by a Production Department more concerned with quantity rather than quality. There are signs that this situation will change and it is particularly important that the Quality Committee continues to function so as to bring the Technical and Production Departments in close daily contact.

5. QUALITY IMPROVEMENTS

The extended Test Runs made it impossible to do very much work on improving the quality of coated papers and boards, and it was particularly disappointing not to run machine trials for a gravure label quality. However, even during the Test Runs, it was evident that the improved base quality imparted many improved features on the final coated product

From the limited amount of work we were able to do it was established that MG board coated on the metering bar coater and finished on the machine calenders, provided an ideal "base" for the blade coater. Also, a paper with 13% filler coated very satisfactorily at 500 metres/minute and gave a gloss of 64% after supercalendering.

In order not to waste time during the Test Run, considerable effort was put into improving the overall quality of Dalaman plain papers. Quite obviously if the Mill becomes quality conscious on all its papers, it does not require too much special effort to produce a good coating base. An attempt was also made to improve the quality of the on-machine coated boards; this proved to be very rewarding since a very good product quality was maintained over a period of several days. When the machine crew held the optimum moisture content (5.5 - 6.0%), the resulting coated board compared very favourably with the quality of the private Turkish Mill, Kartonsan.

Interim Report : SEKA - Turkey

Low moisture content was a great hurdle for the Mill to overcome on all its grades. The problem was compounded by the habit of leaving the doors to the finishing end open. This meant that during the mission very high relative humidity levels were recorded (up to 95%) and since the paper/board was only in equilibrium with 30 - 40% RH, all paper stacks were exhibiting pronounced waves and would be impossible to print without prolonged hanging by the printer. The stacks of board were equally bad and the chromo board curled as well. Towards the end of the mission, when an attempt was made to control both the finishing end humidity and the paper/board moisture content, the situation greatly improved. (See **APPENDIX 5** for graphs of **FINISHING DEPARTMENT RELATIVE HUMIDITIES** and the corresponding **PAPER/BOARD RELATIVE HUMIDITY VALUES**).

A problem with the coated paper was the tendency to ridge and for rope (chain) marks to form. The situation was improved by oscillating the backstand of the winder and by ensuring that the base was as uniform as possible with no wet streaks.

Dalaman has never achieved a good formation, mainly due to a reluctance to use more than 30% short fibre. The base paper made for the Test Runs contained 40% reed pulp and this gave a much closer sheet. The efforts of the Dalaman Mill Manager Mr Hilmi Ogeer to run with higher filler levels is also paying dividends in this respect, although the inability to use the size press makes dusting a very real threat. The Expert believes that it

Interim Report : SEKA - Turkey

would be dangerous to exceed the present 10% filler level without first finding some way of modifying the size press to enable a crease-free sheet to be made.

It is strongly recommended that the Quality Committee meets every morning to review the quality level of the previous 24 hours and that **QUALITY CONTROL** is practised rather than the present quality measurement. **The whole Mill must become quality conscious.** The Expert discussed some ideas how this could be accomplished (e.g. quality display boards in the plant, monitoring performance in the printing and converting plants, training of operators, closer study of the process etc.)

6. LOCAL CHINA CLAY

The local filler clay has earned a reputation of being very abrasive. The problem is compounded by the practice of adding a pre-ground variety directly to the paper and board systems without any form of sedimentation or cleaning (other than the centri-cleaners in the Mill). However, this pre-ground clay is said to have about 40% of its particles below 2 microns and so it was decided to use the Mill clay preparation system (designed to treat crude clay) to clean and classify the pre-ground clay and, hopefully, produce a coating clay. The extended Test Runs gave the Expert time to devote several days to this task.

The clay preparation plant comprises:

- * A hammer mill
- * A rotating ball mill
- * A four-stage cleaning system (centri-cleaner type)
- * Two settlement tanks
- * A screw to remove sand and over-sized particles

(See **APPENDIX 6** for a sketch of the system as used)

In order to treat the pre-ground clay, modifications were made to the flow path through the plant and all the balls were removed from the ball mill. The latter action was necessary because the metal balls of the mill tended to lower the colour of the clay (the original pebbles had been replaced on the basis of recommendations found in the technical literature accompanying

Interim Report : SEKA - Turkey

the mill; the objective was to increase the throughput of the unit. Unfortunately the literature did not warn the customer that there could be contamination of **WHITE** pigments.) In the trial with the pre-ground clay, the ball mill was merely used as a mixer.

The first trial was most disappointing since the final treated clay had a far worse particle size distribution than the material put in. On investigation, this was found to be due to accumulation of clay (over many years!) in both sedimentation tanks. A thorough cleaning operation was carried out which necessitated the disposal of some ten tonnes of rotting clay, after which the trial was repeated. This repetition was far more encouraging and a clay with 46% of its particles below 2 microns was produced. At a convenient time, this clay will be tried either on the blade coater or on the board machine metering bar.

On his way back to Izmit, the Expert visited the producers of the pre-ground clay, Matosan A S. This company has no facility for sedimentation but does have three micronizing units. The proposal is for Matosan to produce a special micronized grade for Dalaman where, on receipt of a 10 tonne trial quantity, the Clay Preparation Section will repeat the sedimentation trials. Hopefully, the resulting clay will approach English and American coating clays as regards particle size distribution although the colour of the local clay is likely to be poor. The overall objective is to see how good a clay can be produced using existing equipment.

Interim Report : SEKA - Turkey

The trials carried out during the mission showed up **TWO** main problem areas:

- * The pre-ground clay contains a quantity of sand and this is no doubt contributing to the abrasion problems in the Mill. The coarser particles are causing damage to the stock and cleaner pumps while the finer particles go on to erode the wire and other moving parts throughout the wet end. It would be prudent to "settle" this sand out **before** the clay enters the papermaking system and it is suggested that the Dalaman Mill considers constructing a simple cascade system before the existing clay preparation system to achieve this objective. Such a system was discussed with the Dalaman Production Manager, Mr Feridun Yalcinkaya.

- * The settlement tank (13-1-408) has an abnormally large gap underneath the scraper unit. The result is a build up of a hard layer of clay which, in time, is attacked by bacteria. From time to time, lumps of this infected clay breaks away and is injected into the papermaking system causing slime formation. Modifications of this scraper to obviate this build up were discussed with the Chief Maintenance Engineer. In any case, at the first opportunity, the whole clay system should be emptied and **thoroughly cleaned**, especially all storage tanks.

7. MEETINGS WITH CUSTOMERS/GENERAL QUALITY COMMENTS

Throughout the mission in Dalaman, the Expert was pleased to see a steady stream of customers and potential customers visiting the Mill for discussions. These visits were used to assess the difficulties experienced by printers and converters as well as carefully evaluating their future requirements. Particular attention was given to coated grades but not to the exclusion of the plain papers and boards.

Customer complaints can be summarised as follows:

* **LOW MOISTURE CONTENT.** This was the complaint of all printers interviewed and all said that their difficulties were ignored by SEKA, except in the case of coated grades where Mr Suleyman Sahin had made considerable efforts to maintain a moisture content of 5.5 - 6.0%. Even worse than Dalaman was the Izmit Mill. Papers from Izmit had to be hung for up to a week before they could be printed.

* **PHYSICAL DEFECTS.** These included holes, creases, lumps, half-sheets and folded sheets. In addition, there were variations in colour, grammage and caliper within reams; these could be seen without any recourse to measurement. In order to minimise these complaints, the Expert recommended that a more stringent quality control scheme should be installed throughout the FINISHING DEPARTMENT, including a careful inspection of all rolls before cutting. The operators should ensure that like papers are cut together

Interim Report : SEKA - Turkey

and that any obviously different rolls should be cut separately.

* **POOR FOLDING QUALITIES OF BOARD.** On this aspect, Dalaman Mill is unfavourably compared with Kartonsan. Rigidity of the Dalaman board is also in question, especially for detergent packs. The use of a starch binder system should help improve rigidity (at the present an all-latex mix is used because of set-back problems with the local starches) and more work should be done on the furnish.

The board made during the mission did not show signs of cracking when folded, but it must be noted that Messrs. Voith were carrying out Test Runs in the WASTE PAPER PLANT and it could be that there was more control of both incoming waste paper quality and process conditions. It should also be noted that this improved furnish contained a multitude of "stickies" and it is doubtful if the printers will be able to cope with the resulting hard, glossy spots in the board. The Mill should keep a close watch on this making throughout the printing and conversion processes, both for improved folding/creasing performance and printing problems associated with the stickies. Quite obviously, the Mill must also seek ways of removing the stickies (the Expert believes that a Voith Engineer has made some recommendations regarding the installation of alternative screens).

Interim Report : SEKA - Turkey

* **POOR PACKING.** The main objection was to the marks pressed into the paper by the end flaps of the ream wrap. The Expert discussed the matter with the Dalaman Production Manager and suggested that a smaller wrapping sheet should be used thus reducing the size of the end flaps (see **APPENDIX 7** for the drawings of a modified wrap). Unfortunately, the paper is sold by weight (including wrapper) so there is little incentive to conform to this suggestion. An alternative is to insert a sheet of board into the top of the ream pack immediately under the outer wrap. It is also advisable to water-proof wrap all offset coated papers. Longer term, it would be better to send out all coated papers and boards palletized and envelope-wrapped (i.e. not ream wrapped) but this depends upon the end user. There must also be a method of marking offset and gravure grades as soon as these products are developed.

During the various meetings, the Expert also discussed a wide range of new products including:

- * Grease resistance (use of CMC)
- * Moisture barrier board for detergent packaging (wax lamination)
- * Gravure label papers
- * Flame retardent papers
- * Higher gloss papers (use of barium sulphate, satin white)
- * High pick offset papers and boards

Interim Report : SEKA - Turkey

Also coming out of these meetings was the obvious need for some form of training programme to be arranged for SEKA customers. Such "customer education" would lead to better understanding between papermaker and printer as well as a possible improvement in finished product quality. A start could be made with the Turkish Monopoly Company, TEKEL, since this organization takes several thousand tonnes of various products from the SEKA Group every month. Perhaps UNIDO/UNDP could provide the vehicle for such a venture.

8. TRAINING/PERSONNEL

The extended Test Runs interfered with the planned formal training programme and only three two-hours lecture programmes were held. In hindsight, perhaps this was for the better since more attention was given to instructing operators on the job. It was thought that the removal of key personnel from the shop floor for classroom training would jeopardise the Test Run, hence the decision that everyone should stay with the job in hand and concentrate on quality. To this end, a brief memorandum was issued by the Expert outlining just what was expected of the Machine Crews (see **APPENDIX 8** for text). However, two and a half volumes of the loose-leaf series **AN OPERATOR'S GUIDE TO AQUEOUS COATING FOR PAPER AND BOARD** was translated by Mr Ahmet Dogukan for distribution to all OPERATORS and TECHNICIANS. The subjects covered by the text are **BASE SHEET PRODUCTION, COATING MIX FORMULATION and BLADE COATING**

It is disappointing to note that the SEKA Managers do not find time to carry out basic training of the lower levels, especially when considering the considerable amount of literature now translated into Turkish. The COATING SECTION has made some attempt to train its personnel but the start-up problems have hindered progress. The Expert has carried out extensive classroom training programmes during previous British Government missions, mainly involving Graduates and Engineers, and SEKA should be encouraged to use this fund of information to impart simplified courses to operators and helpers. Unfortunately, the

Interim Report : SEKA - Turkey

trained graduates tend to leave SEKA and many chances have been lost. Without some form of continuity after an Expert has left it is doubtful if the mission makes any long term impression. Perhaps in future UNIDO missions there should be a Coordinator present throughout the full term of any programme to ensure that follow-up training courses are organised and that all notes created during a programme are **USED**. In the case of Mr Suleyman Sahin, the Expert is sure that every effort will be made to effect a satisfactory training programme; in the other parts of the Dalaman Mill and in the rest of the SEKA Group there is considerable doubt that any follow-up will occur. The Expert hopes to be proved wrong.

There should be a section within the new TRAINING CENTRE to produce visual material for all the SEKA Group training. The Expert favours slide/tape since this method is cheap to produce and can be updated continuously (it is a matter of changing normal 35mm slides within the programme). This subject was discussed briefly with the RESEARCH GROUP. The Expert can, if required, provide full information on the production of training material including slide production, film processing, creation of artwork, simple animation, scripting, voice-over and sound-track production. This could be made part of a fellowship (see later in the report) or could be set up in Turkey; in any case, the Expert would be happy to prepare a sample slide/tape programme on coating free of charge.

Interim Report : SEKA - Turkey

There is also the question of text-books. It is very easy to collect an extensive library of useful reference material and then lock it away. The Expert feels that this may be happening within SEKA, albeit unintentionally. It would be easy to arrange for books of special interest to be loaned out to Mills requiring this information.

The quality of personnel within the COATING SECTION is very good and a credit to the Manager, Mr Suleyman Sahin. This gentleman is doing his best to organize his department and he promotes a high level of morale by communicating with his operators. This is not the case in the rest of the Dalaman Mill where, in some departments, there seems to be little communication both between shifts and with Management. There were signs that the situation was improving, especially in the PAPER MILL where Mr Feridun Yalcinkaya had only been in the position of Manager for a few months. In view of the illness of the Mill Manager, Mr Hilmi Ogeer, the Expert does not wish to be too hard on the Dalaman organization which was under some stress during the mission.

On the positive side, the Dalaman Mill is fortunate in having both Mrs Gurcihan Beslek and Mr Suleyman Sahin in the organization. Both are local inhabitants and show considerable loyalty to Dalaman; both are capable of assuming further responsibility.

9. VISIT TO AFYON MILL

The objective of this visit was to establish the cause of the variable quality of the straw pulp coming from the Mill. Also, it provided an opportunity of discussing the availability of reed pulp which ran well when the Dalaman paper machine was making base for the coating Test Runs. The visit only lasted for a day and so the Expert will not presume to pass detailed judgement on the Mill. The following comments may prove helpful:

- * The large quantity of old, black straw should be written off. There is no point in wasting energy turning this degraded material into a sub-standard pulp, which will give severe problems when used on the paper machine. It is the use of this straw which is giving rise to the very variable drainage on the wire experienced by Dalaman. Ways of converting the old straw to a useful animal feed should be investigated.
- * The pre-impregnation stage is giving trouble. This is not unexpected since a number of modern straw mills are unable to master the problems of moving a wet mass of straw. It is doubtful if the stage is necessary for wheat straw and I suggest that the Mill tries missing out this stage and only adds liquor in the digester. This may increase the throughput.
- * There looks to be a design fault in the approach chute to the low pressure feeder.

Interim Report : SEKA - Turkey

- * The solids of the black liquor after evaporation seem very low and would account for the high consumption of fuel oil. The old straw is not helping matters.
- * The straw handling system is not capable of feeding the cutter house if and when the digester reaches full capacity. The same situation existed in the Deir-Ez-Zor Mill, Syria, designed by the same consultants. The answer is a ground conveyor system and this modification is already under consideration by SEKA.
- * The Laboratory appears to be unsure of its testing methods. It was suggested by the Expert that the Mill sends a sample of pulp to the Cross and Bevan Laboratories, England for evaluation. The Mill can also evaluate the same pulp according to the TAPPI Standard Method (sent to the Mill by Mr Dogukan from Izmit) and the results compared. Cross and Bevan would also comment on the quality compared with pulp samples from other straw mills. This service would be performed free by Cross and Bevan.

10. IZMIT MILL - SECOND PERIOD (10.12.1983 -16.12.1983)

The recommendations for laboratory equipment had already been submitted to UNIDO, Vienna following an appraisal of the Dalaman facilities and plant. The exception was a small pilot coating unit which was to be the subject of further discussions with Dr Judt in Vienna. The other equipment selected was:

- * High Shear Viscometer (Hercules)
- * Water Retention Tester (Warren)
- * Laboratory Mixer (Kady)

The Izmit Laboratory also requires an ink pipette for its IGT Tester and it would be useful if Dalaman had a Bendtsen Roughness/Porosity Tester.

The organization of the SEKA research activity was discussed at length and, eventually, the following scheme was agreed:

- * Each Mill should have its own **SEPARATE RESEARCH UNIT** coordinated by the Research Centre at Izmit. For example, Dalaman would house a small research team specializing in the field of coating. This team would then be in the closest contact with the Production Unit and could speedily undertake product development. Following on this idea, Afyon would have a unit dealing with straw and reed pulping, Balikesir on TMP, Kastomonu on cigarette tissue, Aksu on groundwood etc. These "local" R and D units would be coordinated by the

Interim Report : SEKA - Turkey

Research Centre Team and day-to-day supervision would be carried out by the local Laboratory Chief.

- * Specialist laboratory equipment would go into the appropriate Mill R and D Unit. This will ensure optimum utilization.

- * The Research Centre would work in close contact with the Group Production Directorate lead by Miss Ferhun Taptik. A meeting with Miss Taptik (15.12.1983) discussed this important strategy as well as other matter pertaining to production in general. Later, on the same day, a similar meeting was also held with the new Assistant General Director, Mr Ismet Genc. In both meetings the importance of coordinated research was stressed.

During this period the old cigarette tissue machine at Izmit was examined as a possible pilot machine. The machine is 3.15 metres wide (wire width) and will run up to 200 metres/minute. There are five small spherical digesters and many Hollander beaters and potchers before the machine. Unfortunately, the machine has only a limited drying section and, in its current form, can only dry light-weight papers. However, it would be possible to increase the drying capacity (there is plenty of space) and possibly add a simple metering bar coater. The machine could also be used as a speciality machine when not being used for R and D.

Interim Report : SEKA - Turkey

A new British/TAPPI semi-automatic sheet making machine arrived during this part of the mission and the Expert was able to give some assistance with the installation.

Finally, the following comments should be noted:

- * The new TRAINING CENTRE is almost ready and requires aggressive management to implement worthwhile training schemes.

- * The proposed pilot area in the basement of the TRAINING CENTRE has a question mark over it. Is it worth putting in expensive pilot equipment when it is possible that suitable plant already exists within the Izmit Mill complex? This matter requires careful consideration. It will be very easy to set up an expensive white elephant especially if the dream of a Middle Eastern Research Centre is pursued. Any scheme must take into consideration the needs of an expanding, yet immature Turkish Paper and Board Industry, with a basic need to develop **practical** skills. Perhaps the fundamental research should be left to those countries which have stabilized their pulp and paper industries.

11. FELLOWSHIPS

During the mission, the Expert offered the facilities of the Cross and Bevan Laboratories for the training of selected SEKA personnel. After much consideration, bearing in mind the language problems, the small family nature of Cross and Bevan and the requirements of SEKA, the Expert selected the following for consideration by UNDP/UNIDO:

Ms. Ilksen Teksoy (Chief of Applied Research)

This lady speaks good English and should prove a very useful teacher for future generations of research graduates. A course would be designed to include standard pulp testing, raw material evaluation and design of research projects. Length of course 8 weeks.

Mr Ayhan Mengi (Research Manager)

Mr Mengi has a very good command of the English language and would benefit from a short course on laboratory organization; especially the use of equipment and design of standard methods. Length of course 3 weeks.

Mr Kadir Cobanoglu (Member of Group Production Directorate)

This young Engineer is very keen and spent many long hours in the Dalaman Mill assisting the Expert. His English is limited but he is able to communicate on a technical level. He would benefit from a short study tour in the UK together with a spell in an organization engaged in training and product development. Length of course 8 weeks.

Interim Report : SEKA - Turkey

Cross and Bevan would put their laboratories and associated training facilities at the disposal of UNDP/UNIDO without charge and would only expect UNDP/UNIDO to pay for accommodation of the students and any out-of-pocket expenses (at cost) incurred by Cross and Bevan Staff during agreed visits. The three students could be accommodated at the same time and, if this were possible, Mr Cobanuglu would find communication easier.

Cross and Bevan are also prepared to test up to three pulp samples from SEKA free of charge. The tests could be carried out during the above fellowships if required.

12. GENERAL

The appointment of Mr Ahmet Dogukan to the SEKA Programme was of great benefit during the present mission even bearing mind that he had no previous experience of paper and board making. In order for him to operate, it is necessary for him to have complete cooperation from SEKA and it is especially important for him to have a close working relationship with Mr Ziya Yelen. It would greatly assist the Experts if telexes are sent immediately they are prepared and if mail is forwarded as quickly as possible.

It would also assist many Experts if a typewriter could be made available (**with a QWERTY keyboard**) for typing out notes and reports. Mr Dogukan is an able typist in Turkish, but with a local machine it is rather tedious for him to type in English: it is also difficult for him to read handwritten telexes etc.

13. CONCLUSIONS/RECOMMENDATIONS

Due to the very good cooperation received from all levels of SEKA personnel, the mission achieved many of its objectives; the notable exceptions being in the areas of **production improvement/development** and **formal training**. The failure to achieve the objectives in these areas was due to the Test Runs as already described. In compensation, the work on the development of an acceptable local coating clay was taken much further than originally intended. In view of the limited progress in developing suitable coated grades for the market, it was decided that the Expert should be asked to return sometime in April. This timing was selected as, by that time, the **private company** Meteksan would be producing fine papers from its new mill. This would take the pressure off Dalaman to produce plain papers and the Mill could concentrate on its coated lines. This premature return of the Expert (the return mission is not due until Spring 1985) would be a departure from the UNDP/UNIDO programme and would require special authorisation. The programme could be expected to take 3 weeks and the Expert agreed to make himself available for such a mission if required.

The following recommendations are made as a result of careful analyses made during the mission:

Interim Report : SEKA - Turkey

IZMIT MILL/RESEARCH and TRAINING CENTRE

- * Pay more attention to the stacking of pulp deliveries.
- * De-centralize the research activities by setting up "local" research units. Any specialised equipment should be located in these local units.
- * The Central Research Unit at Izmit should work in close cooperation with the Group Production Directorate under Miss Ferhun Taptik.
- * Before embarking on an expensive pilot plant installation within the Research Centre, it would be prudent to search the Izmit Mill for existing plant that could be used for R and D; for example, the cigarette tissue line.
- * Create a more aggressive training activity.

DALAMAN MILL

- * Cap (cover with a waterproof sheet) all stacks of paper and board as they come off the cutters. This is especially important if the relative humidity of the area is above 70%.
- * Fit flexible self-closing doors to the finishing area.
- * Set up a more positive quality control scheme within the Finishing Section.
- * Encourage all operators and technicians to concentrate on quality.
- * Ensure that the Quality Committee sits each morning to consider the quality level of the previous 24 hours.
- * Keep the on-machine grammage/moisture meters in good working order.
- * Simplify the paper machine calender stack by removing two rolls. It must become normal practice to machine finish all plain papers rather than use the supercalender.
- * Install a bow roll immediately prior to the paper machine size press (to reduce creasing).
- * Consider the installation of spray dampers before the reel-up of both paper machine and board machine.
- * Install a hole detector on the paper machine.

Interim Report : SEKA - Turkey

- * Construct a simple hole marker for the coating machine.
- * Run all paper and board with a moisture content of at least 5.5% (5.5 - 6.0% would be better).
- * Initiate a slime control scheme and ensure that a thorough cleaning programme is observed at each wire-change.
- * Improve the retention of fillers and fines by the use of suitable retention aids (for example, cationic starch).
- * Run cylinders 47 and 49 on the board machine at 60 and 75° to minimise coating pick.
- * Resist the temptation to buy cheap wet felts.
- * Keep a close watch on the new foil table for signs of wear.
- * Design a simple cascade system for settling out fine sand from the pre-ground clay.
- * Take positive steps to reduce the excessive amounts of valuable raw materials going to drain.
- * Follow up the trials using pre-ground clay as a possible feed stock for a coating clay. Repeat using a micronized grade from Matosan A S.
- * Develop separate grades of coated papers for GRAVURE and OFFSET LITHO according to the work carried out by the Laboratory.
- * The Laboratory should continue to evaluate locally produced binders, pigments and additives, working closely with the suppliers to ensure that any development work is relevant to the Dalaman requirements.
- * The Mill must persevere with using more short fibre in the paper furnishes. Until Afyon can sort out its quality problems, it is suggested that some eucalyptus pulp is obtained; this will be especially useful in the production of coating base.

AFYON MILL

- * Cease trying to use the old, rotten straw.
- * Try cutting out the pre-impregnation stage.

Interim Report : SEKA - Turkey

POSTSCRIPT

The Expert wishes to thank the many SEKA staff members for their help during the mission, and for their excellent hospitality throughout. Sincere thanks is also due to Mr Ahmet Dogukan who kept such unsociable hours in order to keep the mission running smoothly.

Trevor W R Dean

APPENDIX 1

PROGRAMME OF TRAINING CARRIED OUT AT IZMIT

Subject areas covered included:

- * Methods of coating.
- * Coating raw materials
- * Particular problems inherent to blade coating.
- * Base paper properties and their influence on final product quality.
- * Printing methods versus paper properties.
- * Evaluation of china clay.
- * Control of curl.
- * Control of micro-surface (of base paper and board).
- * Rheology.
- * Runnability.
- * Evaluation of printability.
- * Customer liaison.
- * Standardized pulp testing in relation to base sheet design.

Laboratory work included:

- * Visual examination of printed and unprinted surfaces.
- * Print recognition.
- * Examination of competitive papers and boards.
- * IGT pick tests carried out.
- * Laboratory refiner used to evaluate Afyon straw pulp.

APPENDIX 1 (continued)

SUGGESTED RESEARCH PROGRAMME FOR CENTRAL RESEARCH GROUP

1. Design of coating bases.

- monitor Dalaman pulp production(*)
- monitor Afyon pulp production(*)
- optimise mixture of above pulps (look at shrinkage and surface).
- if available, look at the effect of imported eucalyptus pulp.
- aim for 60% short fibre/40% long fibre.
- study effects of different filler levels on surface.

(*) send duplicate samples to Cross and Bevan for checking testing method if required.

2. Use of calcium carbonate as a filler.

- collect information and samples of neutral sizing agents.
- evaluate locally **ground** calcium carbonate for purity, particle size distribution and abrasion characteristics.
- compare neutral sized sheets with conventional rosin sized sheets at the same filler levels (strength properties).

NOTE: All testing of (1) and (2) above must be carried out under controlled conditions (23°C and 50%RH) - condition all samples for at least **24 hours** before testing.

3. Refining energy comparisons.

- use laboratory refiner.
- initially compare SEKA pulps then extend to include imported pulps.

4. Comparison of laboratory beating equipment.

- use British/TAPPI Standard Sheet Machine.
- decide upon Standard Method for all SEKA Mills.

APPENDIX 1 (continued)

5. Filler Pre-flocculation.

-at this stage merely collect information.

Also, carry out the following:

- * Familiarize all staff with the use of the IGT Tester. (Remember, for pick tesing **TEMPERATURE IS CRITICAL.**) Develop tests for printing opacity and printability.
- * Design and install a **simple** control system for the conditioned room.
- * Organize regular technical seminars in the new TRAINING CENTRE involving personnel from all the SEKA Mills. Formal papers should be given, overseas suppliers invited, interchange of information should be encouraged.

The Central Research Group should also coordinate the work going on within the Dalaman Mill Laboratory which includes:

- * Evaluation of indigenous raw materials.
- * Product development.
- * Pilot work processing micronized clay for possible coating grade.

APPENDIX 2

REPORT OF THE QUALITY COMMITTEE (18.11.1983) *

1. If we maintain a uniform base, the coating machine performance is good, e.g. 100 tonnes throughput in 2 days, single shift, has been achieved.
2. If we increase the filler content of the base paper and maintain a base moisture content of 5%, we can achieve a commercially acceptable gloss.
3. Using 0.5% local cationic starch on fibre we can maintain an acceptable level of pick strength, internal sizing (Cobb) and tensile at 12 - 13% filler. The trial will be repeated to verify the results.
4. A moisture content of 5.0% can be maintained without giving problems on the paper or board machine. The exception could be with 60 g/m² paper where condensate removal is said to be a problem. In addition, more attention has to be given to profile control on the plain paper supercalender at this higher level of moisture.
5. An improved quality coated chromo board (using the on-machine metering bar coater) has been produced following the regrinding of the Yankee, replacing worn table rolls, removal of the Rotabelt unit and reconditioning of the second calender stack.
6. We have begun formal and informal training as well as holding regular morning meetings (this Quality Committee) to discuss trial results, general quality level and plan future trials.
7. Translation of **BASE SHEET NOTES** has been completed.
8. Laboratory work on indigenous raw materials is continuing as well as work on coating mix formulations for gravure and offset litho printing grades. We are still awaiting samples of potential raw materials.
9. The Lippke grammage/moisture meters are being reinstalled on both paper and board machines: the Lippke Specialist is on site.
10. The water spray unit before the Yankee has been reinstalled.

* For the list of committee members please see **APPENDIX 3**

APPENDIX 3

Composition of the Quality Committee:*

Mr Feridun Yalcinkaya	Paper Mill Manager
Mr M Ali Ergin	Assistant Paper Mill Manager
Mr Suleyman Sahin	Coating Section Manager
Mrs Gurcihan Beslek	Laboratory Manager
Ms Besime Eryener	Chief of Fundamental Research (Research Group, Izmit)
Mr Kadir Cobanuglu	Production Directorate, Izmit
Mr Ahmet Dogukan	Administrative Assistant UNIDO - UNDP
Mr Trevor W R Dean	UNIDO Coating Expert

APPENDIX 4

The diagram below shows the proposed modification of the coating mix feed to the COATING MACHINE. No attempt has been made to scale the drawing.

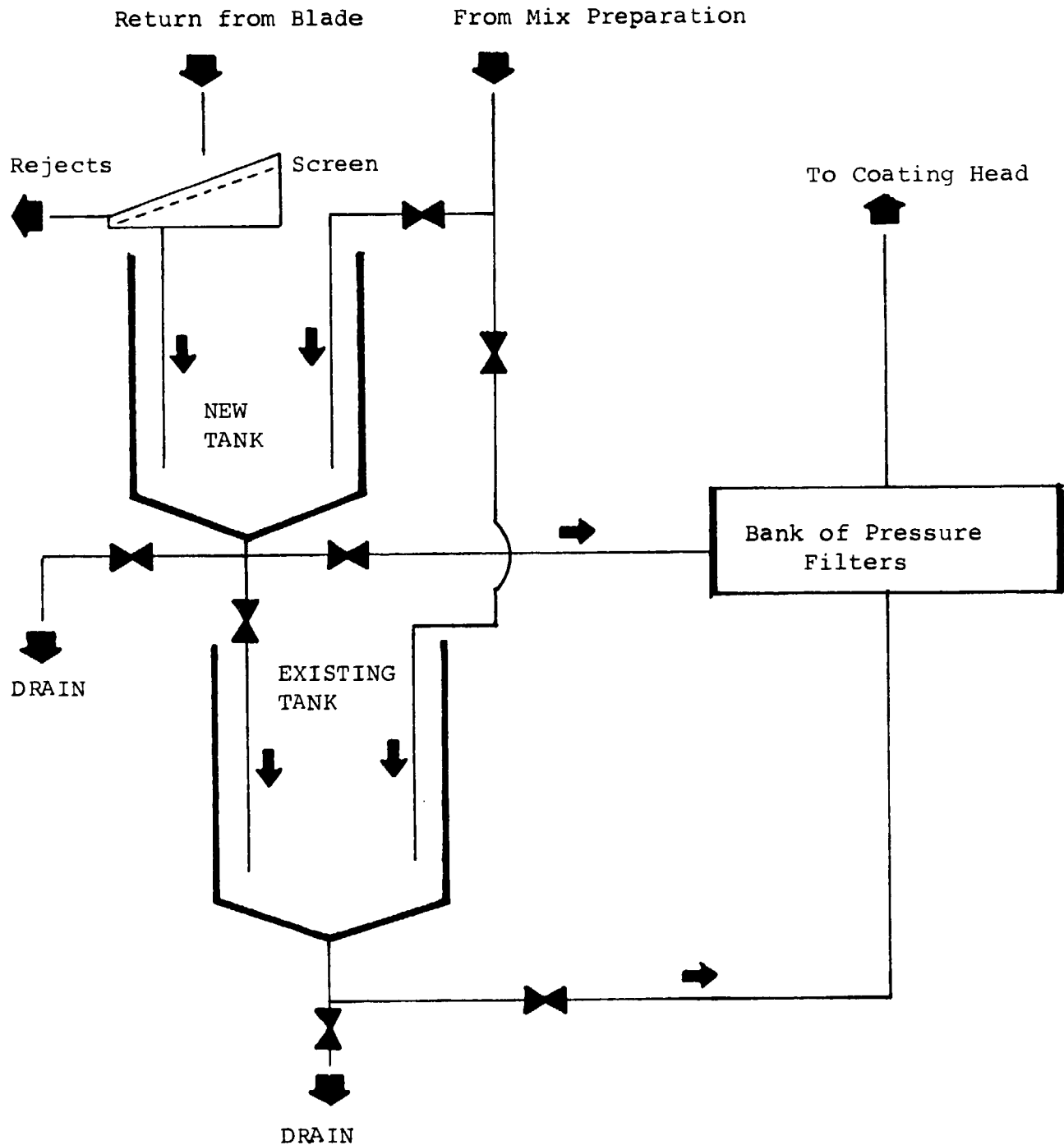

APPENDIX 5

The graphs below show the variations of the following:

Relative Humidity of the Cutter Room

Relative Humidity of the Packing Room

Range of Relative Humidity Values for Papers and Boards stacked in the FINISHING SECTION.

Measurements were taken by Expert throughout the period 09.11.1983 - 07.12.1983.

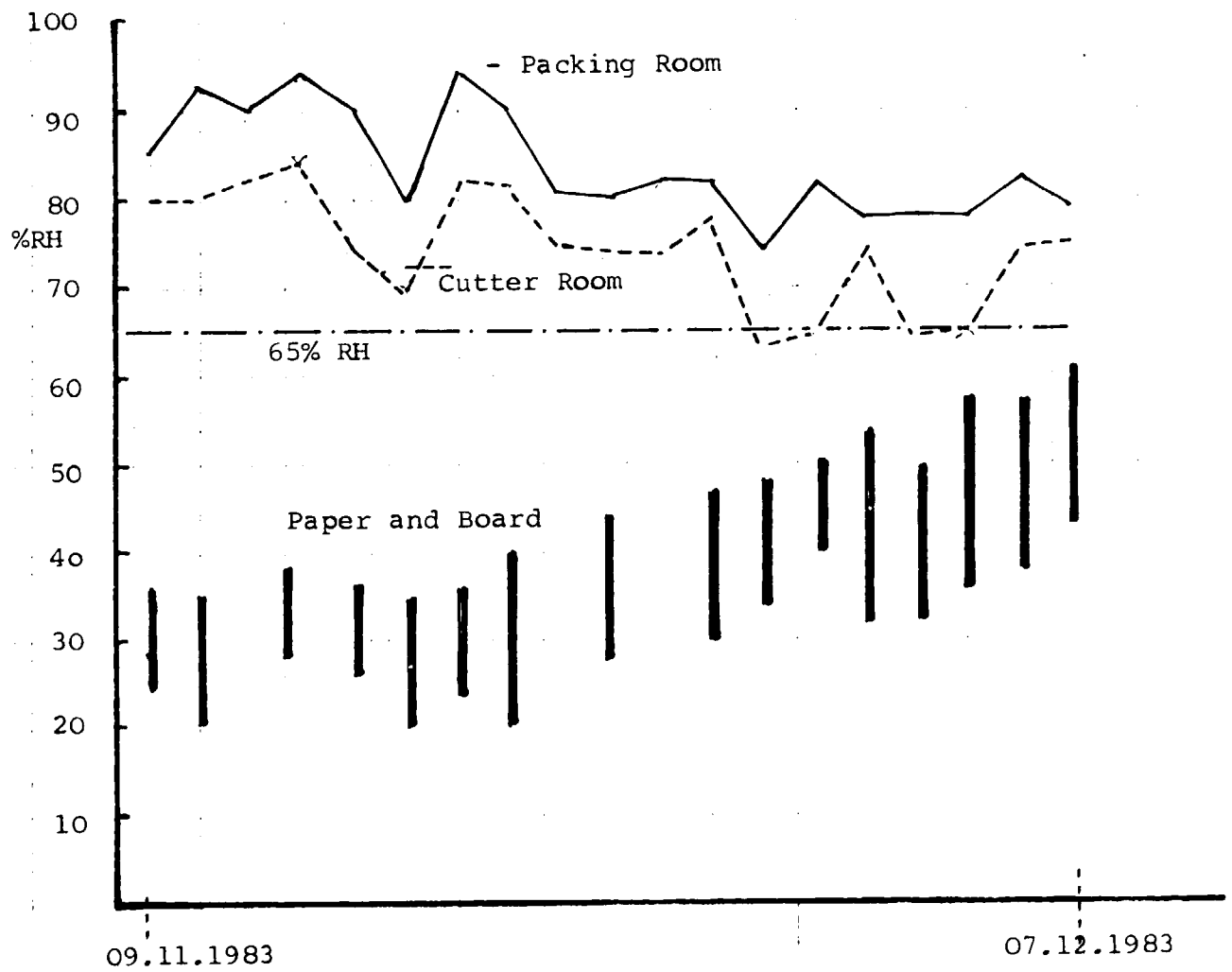

APPENDIX 6

The diagram on the following page shows the Dalaman Clay Preparation Plant after the following modifications had been effected:

- * The balls had been removed from the ball mill which, during these trials, was used only as a mixer.

- * The line carrying the rejects from Group 3 Cleaners was diverted from Tank 13-1-407 to the Screw Unit.

- * The accepts from Group 4 Cleaners went only to the Ball Mill.

- * The accepts from Group 3 Cleaners were fed into the Tank 13-1-407.

- * The Tank 13-1-408 was not allowed to overflow.

- * From time to time slurry was pumped from the bottom of Tank 13-1-407 to the clay storage tank in the Paper Mill to be used as filler.

The report prepared by Mr J M Lintsen (UNIDO Consultant) should be consulted for suggestions as to how the Dalaman plant can be further modified to give an acceptable grade of coating clay.

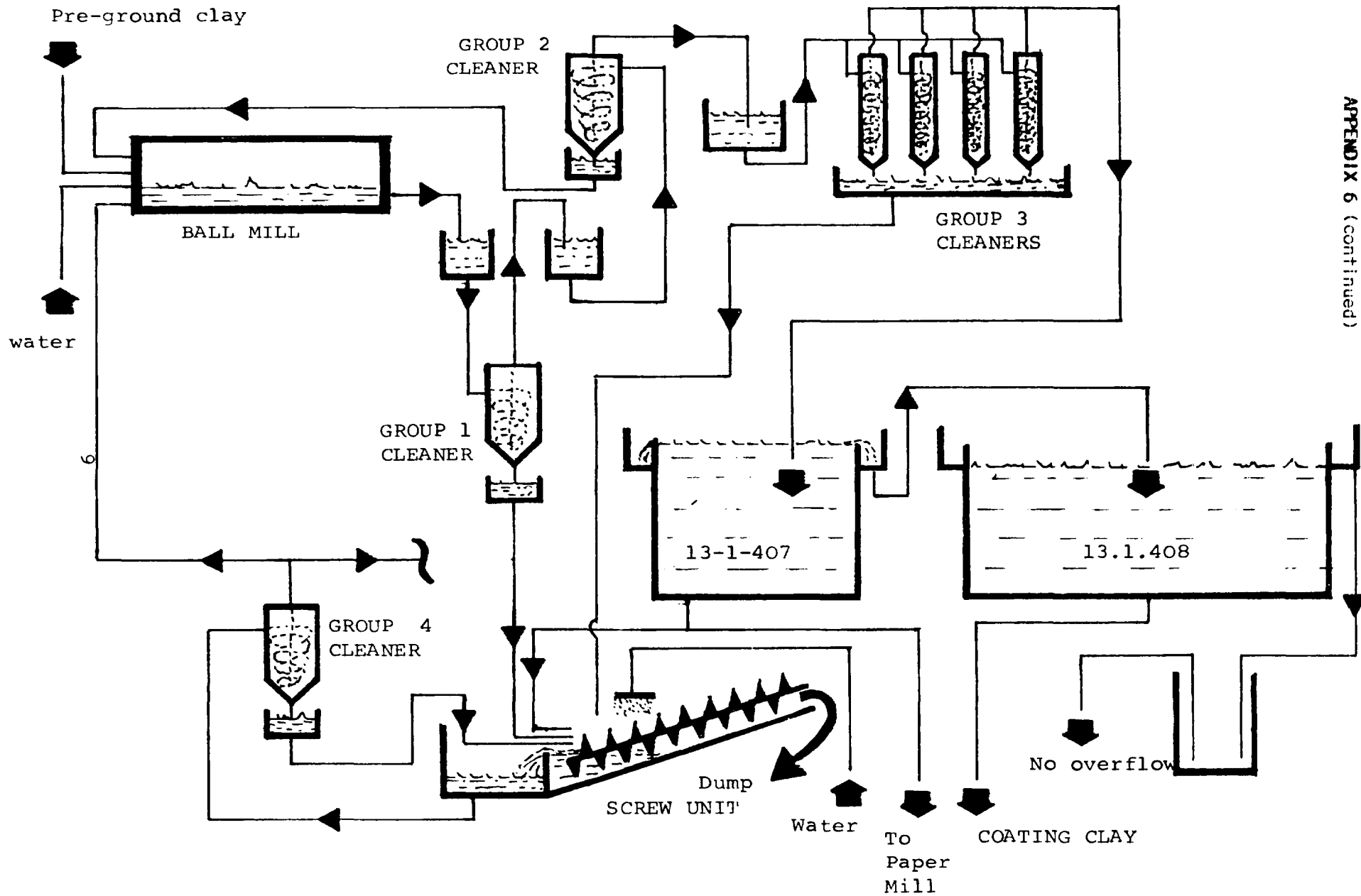

APPENDIX 6 (continued)

Interim Report (appendix) : SEKA - Turkey

APPENDIX 7

The diagrams below show suggested changes in ream packaging:

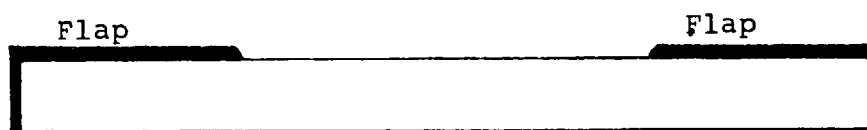

Existing Ream Pack

The "proud" flaps mark the paper when it is palletized.

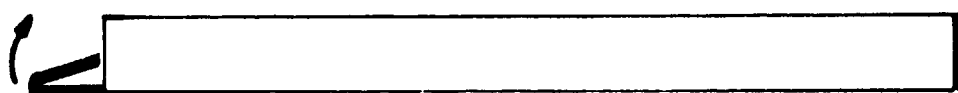

Alternative Pack

Sheet of thick board

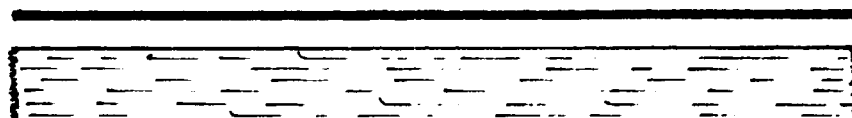

Ream of Paper

APPENDIX 8

Memorandum to the Paper Machine Operators (11.11.1983)

The present trials are being run on the paper machine have the following objectives:

- * To drastically improve the formation which is very poor by international standards: this means using more short fibre (European Mills can use up to 75% short fibre).
- * To reduce the number of defects in the sheet (holes, creases etc.) and improve the overall profile.
- * To increase the moisture content of the sheet to around 6.0% to improve performance at the printers.
- * To increase the level of filler (china clay) in order to reduce costs and improve the gloss of the final coated sheet.
- * To improve the retention on the wire by the use of various retention aids; again to reduce costs and improve quality.
- * To reduce the "edge grain effect" at the sides of the paper web in order to improve runnability on the coating machine.

We must achieve these objectives in order that Dalaman produces an acceptable quality of both plain and coated papers; especially the latter. The improved quality must be achieved while, at the same time, reducing costs. A similar exercise will be carried out on the board machine.

Your cooperation will be appreciated.

