



**TOGETHER**  
*for a sustainable future*

## OCCASION

This publication has been made available to the public on the occasion of the 50<sup>th</sup> anniversary of the United Nations Industrial Development Organisation.



**TOGETHER**  
*for a sustainable future*

## DISCLAIMER

This document has been produced without formal United Nations editing. The designations employed and the presentation of the material in this document do not imply the expression of any opinion whatsoever on the part of the Secretariat of the United Nations Industrial Development Organization (UNIDO) concerning the legal status of any country, territory, city or area or of its authorities, or concerning the delimitation of its frontiers or boundaries, or its economic system or degree of development. Designations such as “developed”, “industrialized” and “developing” are intended for statistical convenience and do not necessarily express a judgment about the stage reached by a particular country or area in the development process. Mention of firm names or commercial products does not constitute an endorsement by UNIDO.

## FAIR USE POLICY

Any part of this publication may be quoted and referenced for educational and research purposes without additional permission from UNIDO. However, those who make use of quoting and referencing this publication are requested to follow the Fair Use Policy of giving due credit to UNIDO.

## CONTACT

Please contact [publications@unido.org](mailto:publications@unido.org) for further information concerning UNIDO publications.

For more information about UNIDO, please visit us at [www.unido.org](http://www.unido.org)

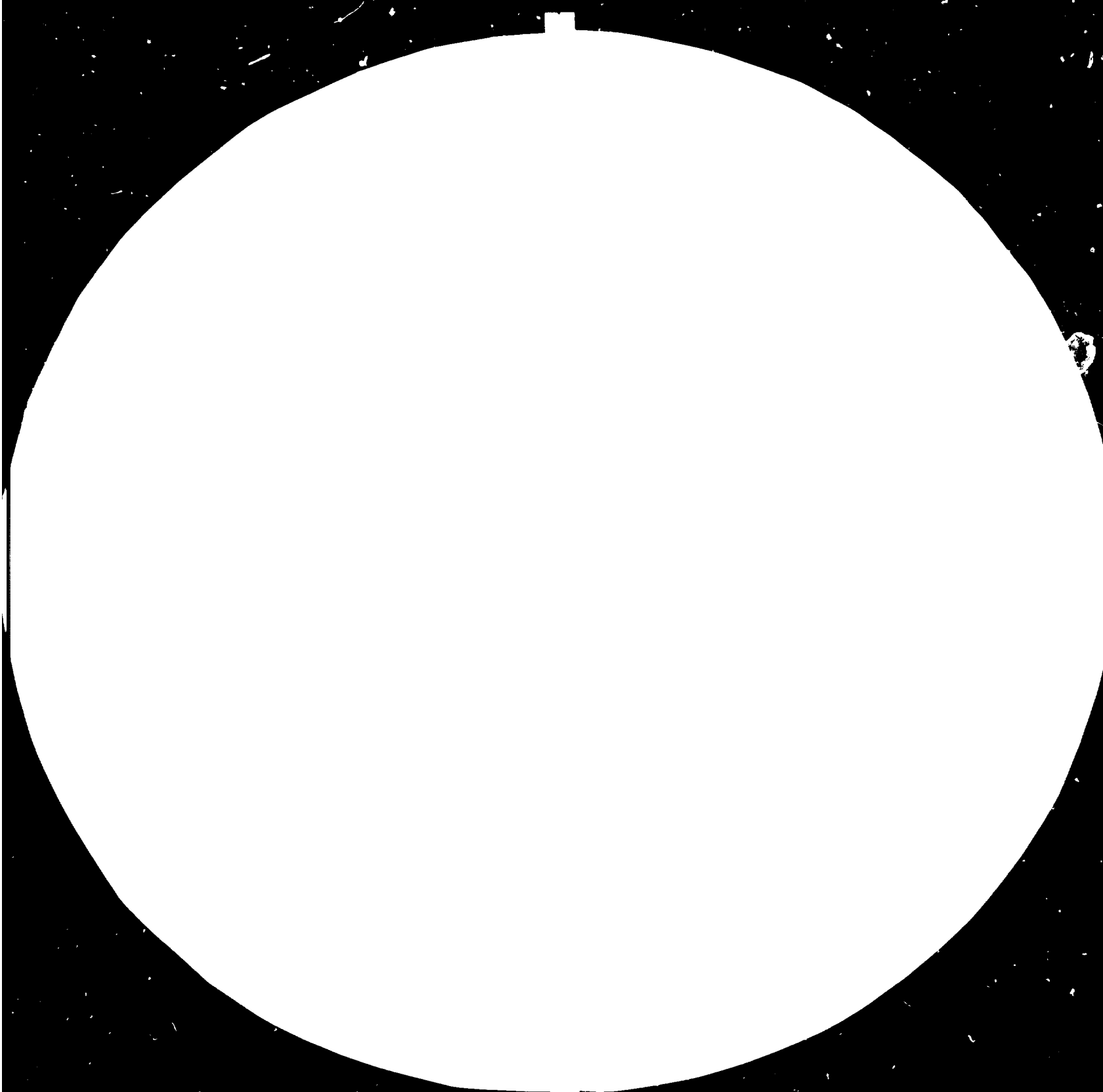



1.0 25

1.1 22



1.2 20



Resolution test charts are used to measure the resolving power of an imaging system. The charts consist of a series of patterns of lines, each labeled with a number representing the spatial frequency. The resolving power is determined by the highest spatial frequency that can be resolved. The charts are used to measure the resolving power of an imaging system by comparing the results of the test with the known resolving power of the system.

13332

RESTRICTED

31 December 1983  
English

(Egypt.)

PLASTICS DEVELOPMENT CENTRE  
FOR AGRICULTURAL PURPOSES

DP/EGY/81/029

EGYPT

Technical Report:      Training Programmes and Promotional Activities

Prepared for the Government of the Arab Republic of Egypt  
by the United Nations Industrial Development Organization,  
acting as Executing Agency for the  
United Nations Development Programme

Based on the work of Gregorio Pruzan, consultant in plastics technology  
and promotional activities.

United Nations Industrial Development Organization  
Vienna

---

This report has not been cleared by the United Nations Industrial  
Development Organization which does not therefore necessarily  
share the views expressed herein.

TABLE OF CONTENTS

	<u>Page</u>
A. SUMMARY.....	1
B. OBJECTIVE OF THE MISSION.....	1
C. CONSULTANT'S ACTIVITIES.....	3
D. RESULTS OF THE MISSION.....	4
E. FINDINGS.....	4
F. RECOMMENDATIONS.....	7
G. ANNEXES.....	16

A. SUMMARY

The training of personnel of the Plastics Development Centre (PDC), for adequately operating their laboratories, pilot plant and experimental station, both for providing technical services to the agricultural and industrial sectors and for training personnel within the above-mentioned areas, is considered as a priority activity.

During the consultant's mission and in agreement with the National Counterpart of the Project, the aspects related to the training of the PDC personnel were specially dealt with, in order to obtain, in a more effective manner, the results envisaged in this phase of the project regarding the development of human resources.

This report contains the observations corresponding to the present situation and recommendations are made for immediate and concrete actions to be taken with the inputs available according to the project budget and within the time-limit assigned for the implementation of the project.

This report also contains results, observations and recommendations on other tasks assigned to the consultant.

B. OBJECTIVE OF THE MISSION

The objective of the consultant's mission (ref. DP/EGY/81/029/11-54/32.1.H) was to collaborate with the national personnel of the project in the following tasks:

1. Prepare training programmes for both plastics technology and plasticulture technology for regular and special seminars for PDC staff and others.

2. Co-operate and advise in the organization of the Water Management Symposia, plastics industry exhibition, and preparation of the material of the promotional activities.
3. Prepare a plastics in agriculture industry survey according to analysis of agricultural demands.
4. Prepare and assist in the preparation of the final report of "Phase I" of the project.

---

NOTE:

On initiation of the mission the National Counterpart of the Project requested that the consultant give priority to the assignments indicated in points 1 and 2.

On the other hand, it must be noted that the duration of the consultant's mission as originally envisaged was 28 days including travel time and debriefing in Vienna. Subsequently, the consultant's stay at duty station was shortened because at the last moment he received instructions to start the mission, almost 10 days after the foreseen date of initiation. Due to other previous commitments with UNIDO the consultant was unable to extend his stay in Egypt, completing his mission at home basis as agreed with the Counterpart.

C. CONSULTANT'S ACTIVITIES

The consultant's activities were carried out during a 28-day mission, including travel time at the following places and dates:

- 20 September to 09 October 1983: Cairo-Alexandria (Egypt)
- 12 October to 16 October 1983: Vienna (Austria)
- 21 December to 28 December 1983: Buenos Aires (Argentina),  
at home basis

The following activities were carried out in cooperation with the National Director and with national and international personnel related to the project:

- Interviews with UNDP, UNIDO and FAO personnel in Cairo. (Annex II)
- Meetings with the Director, Deputy Director and staff members of the following PDC Departments: Technical Affairs, Agriculture, Industrial Cooperation, Training and Quality Control and Testing. (II)
- Visits and meetings with representatives of: the Governorate of Marsa Mathrout, the International Centre for Settlement and Rural Development (ICRD), the University of Kafr el Sheikh, the PDC Experimental Station in Genaclis, the El Gedida Beharya Oasis Project, the FAO Beef Project and the Construction Equipment Co. (II)
- Interviews with UNIDO, Vienna staff members related to the project. (II)
- Obtention, analysis and evaluation of the corresponding information from the country and from abroad, to elaborate the proposals contained in the Results of the Mission and formulate the recommendations stated in this Report. (Annex I)
- Elaboration of a Technical Report including the Findings and Recommendations.



D. RESULTS OF THE MISSION

- Recommendations that include an immediate plan of action for utilization of the PDC physical infrastructure, for training its own personnel and personnel of other institutions in the management of its laboratories, pilot plant and experimental station and preparing them to train personnel in the industrial and agricultural sectors, completing their training with Study Tours.
- Proposal for the organization of a "Water Management Symposium" in Alexandria during 1984 (Annex VII).
- Estimated calculation of the demand for polyethylene films for the construction of greenhouses on 3.000 feddans (1.200 hectares), in a period of eight years, according to a plan issued by the Ministry of Agriculture (Annex VI).
- The Management Board of the PDC obtained the necessary basic information and examples for the preparation of the Final Report of Phase I of the Project.

E. FINDINGS

- The PDC already has a great part of the basic infrastructure comprised of laboratories, pilot plant with necessary equipment, apparatus and instruments to offer technical services to the industrial sector and to the agricultural sector, a potential user of plastics, in the field of product development, application, formulation and processing, quality control and standardization, training, etc.

- In the near future, the PDC experimental station at Genaclis is expected to initiate its activities. At this station, experiments will be carried out to evaluate the behaviour of plastic materials, the systems of installation of same, and the agricultural results corresponding to the various crops.
- The PDC's physical capacity for providing the above-mentioned services is limited, as the personnel is not yet technically and managerially prepared to efficiently operate the various PDC departments nor is the necessary technical and professional personnel available as yet.
- Therefore, in the field of training, and with some exceptions at the laboratory level, the PDC is not yet prepared to organize courses and seminars for personnel of the industrial and agricultural sectors and to evaluate the results of these courses using the pilot plant and experimental station.
- Within the referred exception, it must be mentioned that during 1983 the PDC carried out, in its own laboratories, the First theoretical-practical course on the Introduction to Polymer Science, for personnel of the Egyptian Petrochemical Co., with the cooperation of the University professors.
- On the other hand, there has been an increasing interest of certain raw material and plastic processing firms, in training their personnel both in the field of plastics technology and in plasticulture.
- The PDC has reached an agreement with the Ministry of Agriculture for training agronomists, technicians and farmers in this speciality.
- Nevertheless, so as to be able to determine the type and level of courses that the PDC should give, the real demand of the market, regarding the subjects that would be of its interest and the personnel that would take part in the courses, is not known in detail. Also unknown are the needs as to the other services that could be required from the PDC.

The training activities of the PDC will be coordinated by the National Training Committee comprised of representatives from petrochemical and plastics industries and from the agricultural sector. The existence of formal contacts with associations or representative groups of the plastics industry has not as yet been verified.

On the other hand, the National Committee of Plastics in Agriculture has not carried out the activities foreseen to start together with the initiation of the project's implementation.

- For the organization of future courses in the area of polymers, the PDC hopes to count on the collaboration of professors belonging to the Chemical Department of the Faculty of Engineering in Alexandria; and for the area of plasticulture, PDC hopes to count on the assistance of the professors from the Faculty of Agriculture of Kafr el Sheikh.
- Apart from the above-mentioned Universities, the ICRD has expressed its interest and has the necessary facilities for cooperating in the execution of theoretical-practical courses in plasticulture, at the level of small holders, graduated and newly graduated professionals.
- It is unknown whether personnel of other Universities, Centres, Institutes and Industries would be qualified to cooperate as trainers in courses and seminars organized by the PDC.
- The majority of the PDC staff has had the opportunity of making study tours abroad (generally short term tours) for acquiring and enhancing their knowledge in different areas, knowledge they have also received through UNIDO consultants and from the technicians sent by the firms that provided the equipment and apparatus purchased by the project.

- The knowledge acquired can be considered as a general acquaintance with the subject matter, both in the field of plastics technology and of plasticulture, and does not contain the necessary components to endow the PDC personnel with the didactic capacity to enable them to transmit their knowledge to third persons both at the theoretical and practical levels.
- With reference to bibliographical assistance, the PDC library has very few books and publications on plastics technology and polymers and practically none at all on plastics applications in agriculture.

F. RECOMMENDATIONS

With relation to the observations made in the previous section, the following recommendations are oriented principally to the urgent need of establishing an immediate plan of action for training the PDC staff at a higher level, preparing them for the future implementation of training programmes for the personnel of the industrial and agricultural sectors, and for operating the technical assistance services to the industry, using the infrastructure already available.

- In the area of plastics technology, the consultant recommends the establishment, through a market study, of the needs and potential demand of the plastics industry regarding the services it could require from the PDC and including the training of the companies' technical personnel.
- In order to prepare a training programme, priorities must be determined according to demands; another point is the establishment of the subjects to be developed, at what level and for how many participants.

- Once the above information has been obtained, it will be possible to determine the characteristics of the programmes and theoretical-practical training plans to be carried out within the existing infrastructure at the PDC and at other cooperating institutions in the country. It will then also be possible to specify the resources available in the project during the period assigned for its implementation.
- In order to carry out the referred programmes it is necessary to have technical personnel qualified for teaching activities. Therefore, the immediate plan of action proposes the training of said personnel, i.e., the "training of trainers".
- For implementing the proposed plan of action as of 1984, the consultant recommends, in the first place, that two PDC staff members and a UNIDO consultant, with experience in offering services to industries and in training personnel, prepare a questionnaire for gathering information from the industrial sector on processing technology, raw materials, moulds and dies, production, development of new products and their applications, technical and information services, training of human resources. The estimated period of time necessary for elaborating, reviewing and approving the questionnaire is calculated at one month, including the training of the personnel that will carry out the survey and the selection of the companies to be visited.
- Once the questionnaire has been made up the consultant recommends that two PDC staff members, working on a full time basis, visit the industries chosen for the survey and complete the referred questionnaire. It is estimated that between them, the surveyors will be able to visit 200 industrial plants within three months and consequently have an equal amount of completed questionnaires. This cipher corresponds to more than half of the total estimated number of plastic industries in Egypt.

- The interviews may also be useful for promoting the PDC's activities and offering the services it is capable of providing, through a brochure that may be elaborated during the month of preparation of the questionnaire.

Once the proposed survey is finalized the answers contained in the questionnaires should be classified, analysed and evaluated to determine future actions. This stage may require a month's work of the UNIDO consultant and of both the PDC staff members.

It is recommended that, apart from the PDC staff, researchers and professors of Centres and Universities related to the subject of polymers and plastics and professionals of the plastics industry, that in the future could cooperate in the training programmes for personnel of the industrial sector, should also participate in the proposed programmes. The necessary consultations should be made so as to identify the above participants.

In what specifically refers to training, the necessary priorities should be determined to elaborate a programme of seminars, specialized in different subjects. The participants of these seminars will include PDC staff as well as the professionals identified as per above, endeavouring that the number of participants does not surpass the amount of fifteen (15).

- It is recommended that the seminars be intensive, with an average duration of five days (approximately 40 hours), including theoretical and practical activities as well as the evaluation of the results. The programming of a seminar every three months is considered reasonable.
- The participants, and specially the PDC personnel, will not only enhance or acquire technical, theoretical and practical knowledge on the subject matter, but also become familiarized with the didactic methods for giving courses and similar seminars themselves, either at the PDC or at other plants and institutions.

The suggested training procedure aims not only at preparing national personnel to train other persons, but also at training this personnel for the utilization of the PDC equipment, specially that of the pilot plant, in order to initiate technological development work, technology adaptation and to provide several services to the industry.

- The seminars suggested will be conducted by UNIDO consultants, according to the speciality involved. These consultants will also be responsible for assisting the national personnel in the organization of the seminars, the elaboration of the programmes, the theoretical and practical activities, in providing written didactic material for each complete seminar and in carrying out the corresponding evaluation. The duration of each consultant's mission will be of 1.5 months for each seminar, including the necessary time for its organization, implementation and evaluation.
- The seminars will be held at the PDC, using its ample facilities, in its laboratories, pilot plant and classrooms, which will thus start to operate actively.
- It is recommended that during the time needed for the elaboration of the questionnaire, the survey and the collection of the pertinent data, the first seminar on Plastics Extrusion be organized, following the procedure proposed. Besides being one of the most used transformation processes, plastics extrusion is also employed for the manufacturing of important agricultural inputs, such as films and pipes. The experience derived from this seminar will be used for the organization of those which will follow and which the national personnel will repeat, according to demands. (Annex III)

Regarding the availability of books and magazines, it is recommended that the PDC increase the amount and improve the quality of those which it now possesses, following the advice of the consultants of each speciality.

- In order to enable the access to technical literature on plastics technology in Arabic, it is recommended to subscribe to the publication issued in Arabic and English by International Industry and Technology, P.O. Box 140252, D-5300 Bonn 1, Federal Republic of Germany. This firm can also prepare, upon request, technical translations from English into Arabic on subjects related to plastics.
- It is recommended to complement the training of national personnel by study tours abroad, at institutions specially identified for the subject(s) to be improved. It is advisable to increase the stay at a selected centre instead of carrying out brief visits to several places.

Concerning the training in plasticulture, although the same recommendations made for plastics technology may be followed, using the facilities that the PDC offers with its experimental station, and those of other institutions as the ICRD, it is suggested to initiate activities by study tours to countries with the necessary structure and experience for the training required for the PDC personnel.

In the field of polymers and plastics technology, there are several centres or institutes throughout the world where PDC personnel has been trained and may continue doing so. This does not apply to the field of plastics development in agriculture. Most of the activities in the area of plasticulture were carried out by raw material producing companies which organized and created their own experimental stations for this purpose.

In some other cases, certain governments, through specific projects, and some centres and universities have been concerned with the introduction of the subject of plastics utilization in agriculture.



- In order to accelerate the diffusion of these techniques and set an adequate communication basis, it is necessary to count on a team trained in the management of the technological package which involves the utilization of plastics in agriculture, both from the agricultural and industrial points of view.
- Once this team is trained, it will be in better conditions for organizing training courses in several specialities of plasticulture, for personnel at different levels of the agricultural and industrial sectors.
- Therefore, it is recommended that the PDC personnel be trained at some centre or institution with enough competence and organization to carry out those functions, not only regarding the application of the materials, but also the handling of the information derived from such application, both at experimental and commercial levels, taking into account plastics behaviour and agricultural results.

The above-mentioned institution should have the necessary basic infrastructure, such as equipment, facilities and technical personnel with didactic capacity to develop both theoretical and practical activities.

It is considered that most of these conditions are met by L'Institut National de la Recherche Agronomique (INRA), at the Station Experimentale Horticole du Mas Blanc, in Alenya-Perpignan, France, which, together with Le Centre d'Etudes de Matières Plastiques of Paris, has studied a draft programme for the research, technical assistance, information and training for the development of plastics in agriculture, specially for developing countries, with one course oriented to agriculture and another to industry (Annex IV ).

At the same time as the feasibility of participating in training programmes abroad is explored, it is recommended that the PDC, with the assistance of UNIDO consultants and in close co-operation with other institutions related to research, training and agricultural expansion, organize brief courses on Introduction to Plasticulture,

for technicians , agronomists and farmers from the agricultural departments of the villages.

The document "State of Art Paper for the Practical Uses of Plastics in Arid Land Development", prepared in 1981 with the collaboration of UNIDO, is attached herewith as a guide for the theoretical development of the above-mentioned courses. (Annex V ).

The experimental station of Genaclis may be used to carry out some practical work, complementary to the theoretical courses and according to a schedule to be elaborated together with the PDC personnel, by a UNIDO consultant, specialized in plasticulture, preferably with experience in theoretical and practical training programmes.

The Plasticulture Journal, published by CIPA, is one of the most important elements to keep PDC personnel informed and to disseminate the issues of highest interest for the country. It is recommended that, besides taking the necessary measures in order to receive this journal regularly, the issues of the last five years be purchased. These issues will be useful as reference documentation as well as information, didactic and promotional material.

It is recommended to re-establish the activities of the National Committee of Plastics in Agriculture, which will be useful to contribute to the training and divulgation programme suggested.

Both for plastics technology and plasticulture, and in order to strengthen the training plan with regular education programmes, it is recommended to contact the national educational authorities who are responsible for the technical and university levels, in order to consider the basis and conditions to introduce courses related to the above-mentioned subjects as a part of the regular study programmes.

It is recommended that the success criteria for the training programmes be verified by the National Training Committee.

To summarize, the recommendations proposed will contribute to obtain the following results, envisaged by the project, upon its termination at the end of 1985:

- Fifteen members of the PDC professional staff qualified in activities of training in plastics technology and plasticulture.
- A document containing the respective programmes and the complete development of each subject corresponding to the courses and seminars held (theory and practical guide).
- One hundred technicians and professionals belonging to the industry and other institutions, trained in several areas of plastics technology and plasticulture.

The following schedule is suggested for the activities proposed:

February to June 1984: Preparation of questionnaires, visits to companies and institutions and elaboration of the report on market demand.

June 1984: First theoretical-practical seminar for trainers, on the subject of extrusion.

July 1984 to November 1985: Six seminars for trainers, on the subject of plastics technology and two on plasticulture, with the corresponding didactic material, covering the subjects determined by the demand.

September 1984 to December 1985: Courses and seminars for personnel belonging to industry and other institutions, according to demand, to be conducted by trainers, and on the same subjects which were prepared for them.

April 1984 to May 1985: Study Tours of national personnel for specialization.

Regarding the Symposium of Plastics in Water Management, it is recommended to consider in detail, apart from the technical issues it will deal with, the role that the PDC, as well as the industry and the consumer sectors should play in order to improve the development of the applications and have access to the technology for local product manufacturing, thus substituting imported goods. This recommendation is also applicable to other symposia which may be held.

G. LIST OF ANNEXES

- I. REFERENCE MATERIAL
- II. INTERVIEWS
- III. PROGRAMME FOR A SEMINAR ON EXTRUSION
- IV. STUDY PROGRAMMES ON THE APPLICATION OF PLASTICS IN AGRICULTURE
- V. STATE OF ART PAPER: PLASTICS IN AGRICULTURE
- VI. CALCULATION OF THE DEMAND FOR FILMS TO BUILD GREENHOUSES
- VII. PROPOSAL FOR A SYMPOSIUM OF PLASTICS IN WATER MANAGEMENT

ANNEX I

REFERENCE MATERIAL

## REFERENCES

- PDC-UNIDO Project, Egypt, 1982  
Plastics Development Centre for Agriculture
- CENAMAR, México, 1982  
Curso sobre Usos de Plásticos en la Agricultura
- ANDREWS K.G., U.K., 1982  
The Egyptian Plastics Industry
- UNIDO, Vienna, 1981  
A State of Art Paper for the Practical Uses of Plastics  
in Arid Land Development
- MENGENS, THIM, KAUFMAN, Austria, 1981  
Technologie Lernprogramm der Kunststoffe
- INSTITUTO PLAST, Argentina, 1983  
Programas de Seminarios y Carreras de Técnicos en Plásticos  
y Auxiliares
- SOCIETY OF PLASTICS ENGINEERS, USA, 1983  
Catalog of Seminars for Plastics Professionals
- THE PLASTICS AND RUBBER INSTITUT, U.K., 1983 (RAPRA)  
Publications Catalogue
- ALLAN GRIFF, U.S.A. 1983  
Plastics Extrusion Operating Manual
- EDUCATIONAL SERVICE OF RAPRA  
Sources of Information on Plastics and Rubber
- INSTITUT FÜR KUNSTSTOFFVERARBEITUNG, Fed. Rep. of Germany, 1983  
Forschung für die Praxis
- LKT-TGM. Austria, 1983  
Technology Transfer and Development
- RAPRA AND THE EDUCATION SERVICE OF THE PLASTICS INDUSTRY, U.K., 1983  
Courses in Plastics and Rubber
- INRA-CEMP, France, 1982  
Pasticulture-Programme de Formation

- J.C.GARNAUD, France, 1982

Pdc/Unido Project Reports

-SUD-DEUTCHE KUNSTSTOFFE ZENTRUM(SKZ), Wurtzburg, 1983

Lehrgänge, Seminare, Beratungen

-TECHNISCHE UNIVERSITÄT BERLIN, 1983

Kunststoff Technik

-SKZ, 1983

Aufgabengebeite, Institutseinrichtungen

-SKZ, 1983

Forshung und Entwicklung des SKZ als Grundlage Ffür den  
Technologie Transfer

-FELIX ROBLEDO DE PEDRO-LUIS MARTIN VICENTE, España, 1980

Aplicaciones de los plásticos en la agricultura



ANNEX II

INTERVIEWS

Mustafa Sultan	Marsa Matrouh Gov.
Farouk El Aidy	Kafr El Sheik Univ.
Sayed Abd El Razik	El Gedida Mines Baharya Oasis
William A. Hargus	FAO Beef project
Sabry I. Talkhan	Construction Equipment Co, Alex.
Nadia Makram Ebeid	UNDP, Cairo -FAO
Osman Abou Zeid	PDC, Alex.
Nadia Nosseir	PDC, Alex
Nasrat G. Ghobrial	Medical Packing Co.
F. Hartvelt	UNDP, Cairo
Tarwat Sabry	UNIDO, Cairo
Hesham M. Hussein	PDC, Alex.
Essam M. Mitwally	UNDP, Cairo
Mohamed Kamel	PDC, Alex.
Sayed El Sayed	PDC, Alex.
Magdy Garib	PDC, Alex.
Baghed Mousa	PDC, Alex.
Abdel Khalek Soliman	PDC, Alex.
J. Neil McClure	NAECO
Fawzy Abd El Kader	ICRD, Maryut
Salah El Esawy	ICRD, Maryut
Robert Anderson	UNIDO Consultant, Alex.
Herbert May	UNIDO, Vienna
Magdy Youssef	UNIDO, Vienna

ANNEX III

PROGRAMME FOR A SEMINAR ON EXTRUSION

## EXTRUSION SEMINAR PROGRAMME

Objective : The seminar is designed to develop a complete understanding of the entire extrusion process. Learn the basics of the extruder components, operating principles, material properties, troubleshooting, screw design, etc. The use of math and how it relates to extruder technology will be kept to a minimum in order to involve people of various disciplines.

### Course outline:

Introduction to extrusion  
Drive system  
Special screw design  
The head zone  
-Breaker plate  
-Screens  
-Screen changers  
-Cleaning breaker plates and small parts  
-Gate  
-Temperature measurement  
-Pressure measurement  
-Adapter  
-Valve  
-Static mixer  
-Gear pump  
-Coextrusion feed blocks  
Extrusion dies  
-Resistance  
-Streamlining  
-Heating  
-Materials of construction  
-Dimension control  
-Low level orientation  
-Calculations and trial designs  
What happens in the barrel  
-Feed zone  
-Melting zone  
-Metering zone

Heating and cooling  
Setting conditions  
Maintenance  
Safety  
Start-up  
Material change and shutdown  
Common extrusion problems  
-Surging  
-Poor mixing  
-Melt fracture  
-Overheating  
-Moisture  
-Trapped air  
-Fisheyes  
Materials for extrusion  
Special extrusion systems  
-Twin screw extrusion  
-Tandem systems  
-Coextrusion  
-Pultrusion  
Bibliography and information

ANNEX IV

STUDY PROGRAMMES ON THE APPLICATION OF PLASTICS

IN AGRICULTURE

FRENCH

PROGRAMME DE FORMATION

PLASTICULTURE

POUR DELEGUES DU TIERS MONDE

(EN COOPERATION AVEC LE COMITE INTERNATIONAL des PLASTIQUES  
EN AGRICULTURE (C I P A))

GESTION ADMINISTRATIVE: C I P A

ENSEIGNEMENT : INRA/ CEMP

Le programme s'adresserait à:

- 15 personnes environ,
- Niveau techniciens supérieurs et ingénieurs

et comporterait 2 options:

a. Plasticulture - Option agronomique

- 4 semaines de formation agronomique
- 1 semaine de formation industrielle et visites d'usines.

b. Plasticulture - Option industrielle

- 4 semaines formation industrielle
- 1 semaine formation agronomique avec visites de stations  
expérimentales

a. PROGRAMME PLASTICULTURE - OPTION AGRONOMIQUE

a.1 Définition du programme

- 80 heures enseignement théorique agronomie (INRA)
- 30 heures application pratique sur le terrain (INRA)
- 40 heures enseignement industriel (CEMP) - Visite usines (ICPA).

Enseignement théorique

- Les différents matériaux employés en agriculture: avantages et inconvénients 8 heures
  - Retenue et transport de l'eau 8 heures
  - Utilisation des films : en paillage, en semi-  
forçage 8 heures
  - Stockage des aliments 4 heures
- 
- Les serres et les abris 32 heures
    - . Historique
    - . Problèmes de charpente
    - . Les différents types d'abris
    - . Notions de physiologie: Besoins en eau et en éléments fertilisants des plantes.
    - . Le climat de l'abri
    - . Les économies d'énergie
  - Quelques notions sur les principales espèces légumières et florales cultivées sous abris 20 heures
  - Principaux systèmes d'assolement

---

Total enseignement théorique ..... 80 heures

Enseignement pratique ..... 80 heures

Les stagiaires participeraient:

- à des opérations de paillage et de semi-forçage
- à la réalisation de retenue et de transport  
/d'eau
- à la construction et à la couverture des abris
- aux vérifications de contrôle du climat
- aux actions d'équipement dans les serres

Enseignement industriel - Visites d'usines

- Techniques de fabrication
- Techniques d'essais et contrôle 8 heures
- Normes et Marques de Qualité
- Visites d'usines 30 heures



4.2 - Conditions générales d'inscription.

Le stage aura lieu chaque année, de préférence au printemps, au moment des récoltes, soit en Mars-Avril, soit en Avril-Mai. Le mois d'Avril est à retenir en priorité, pour la partie agronomique.

Les cours auront lieu à la station expérimentale d'ALENÇA, en collaboration avec le Centre des serristes de INEZA.

5. PROGRAMME PLASTICULTURE - OPTION INDUSTRIELLE

5.1 - Définition du programme

160 heures d'enseignement industriel théorique et pratique alterné (CENP)

40 heures d'enseignement agronomique (INRA) - Visite de stations et réalisations agricoles (CPA)

- Enseignement industriel (théorique et pratique alterné) par produit et demi-produit:

Films et Feuilles ..... 60 heures

Incolores et colorés  
Pour serres, paillage, ensilage, réserves d'eau, /sacheries, ...

Grilles ..... 10 heures

Brise-Vents , ombrières, ...

Tubes ..... 60 heures

. PE hd, PE bd, PVC, pour le transport d'eau sous pression, l'assainissement, l'évacuation des eaux bâtiments.

.Drains

. Goutte à goutte

Conteneurs et produits livrés..... 8 heures

Réservoirs..... 22 heures

Silos à grains, stockage d'eau, d'engrais de pesticides, en thermoplastiques et plastiques armés, réalisés par rotation, soufflage ou technologies de plastiques armés de fibres de verre.

Pour chaque demi-produit, on étudiera:

- Matières : Fabrication - Propriétés
- Technologies de mise en oeuvre
- Méthodes d'essais
- Propriétés et applications
- Normalisation et Marques de Qualité
- Visites d'usines.

- Enseignement agronomique - Visite de stations

- . Les différents matériaux employés en agriculture: avantages et inconvénients sur le plan agronomique 6 heures
- . Visite de stations et de réalisations ..... 30 heures  
/ agricoles

b.2 - Conditions générales d'exécution.

Les cours seront faits en Français et (ou) en Anglais, de préférence en dehors de la période Juin à Septembre

- . soit dans les installations du CEMP
- . soit dans les établissements associés (Ecoles d'Ingénieurs, Lycées techniques, industries, ...) présentant les meilleurs équipements industriels.

ANNEX V

STATE OF ART PAPER:

PLASTICS IN AGRICULTURE

## TABLE OF CONTENTS

LIST OF TABLES .....	iv
LIST OF FIGURES .....	v
INTRODUCTION.....	1
PRODUCTS AND USES .....	2
Irrigation .....	2
Management of Trickle Systems.....	3
a. Irrigation Scheduling .....	3
b. Cultural Practices .....	3
c. Chemical Applications .....	4
d. Automation .....	5
Maintenance of Trickle Systems.....	5
a. Water Filtration .....	6
b. Field Inspection .....	6
c. Pipeline Flushing .....	6
d. Chemical Water Treatment .....	6
Comparison of Irrigation Systems .....	8
a. Advantages of Drip Irrigation .....	8
b. Constraints of Drip Irrigation .....	8
Greenhouses and Greenhouse Production .....	10
University of Arizona Approach to Controlled Environment Agriculture (CEA) .....	10
a. Water Conservation .....	11
b. Yields .....	12
c. Energy Needs .....	12
Mulch .....	15
Mulch Installation .....	15
Principles, Practices, and Problems.....	17
Mulching Technique for Arid Lands Vegetable Production .....	18
Water Conservation .....	21
Water Catchment Methods .....	21
a. Compacted Earth .....	21
b. Salt Treated Compacted Earth .....	21

TABLE OF CONTENTS (continued)

c. Gravel Covered Plastic .....	22
d. Wax Treated .....	27
e. Fiberglass Asphalt Chipcoated (FAC) .....	27
f. Asphalt-Rubber Chipcoated (ARC) .....	28
Water Storage Methods .....	28
Water Harvesting Systems .....	30
Water Harvesting Agrisystems .....	30
a. Rainfed Urban .....	32
b. Rainfed Industry .....	32
References .....	35

## LIST OF TABLES

1. Uses of Plastics .....	2
2. Tentative Criteria for Classifying Potential Clogging Hazard of Irrigation Waters to be Used in Trickle Systems .....	7
3. Comparison of Irrigation Systems .....	9
4. Water Consumption - Controlled-Environment Versus Open-Field Agriculture .....	11
5. Yields of Crops Grown in Abu Dhabi Greenhouses .....	12
6. Comparative Yields and Energy Usage for Vegetables Grown in Greenhouses Versus Field Grown .....	13
7. Squash Yield for Treatments Used in Plantings, 1969 and 1970 .....	20
8. 1981 Cost Estimates of Different Water Harvesting Methods .....	22

LIST OF FIGURES

1.	Plastic Laying Gravel Spreader .....	23
2.	Proposed Modification of Chio Spreader for Installation of Plastic Membranes .....	25
3.	Gravel Extracting Soil Sifter .....	25
4.	Shape of Proposed Catchment Systems .....	31
5.	Water Harvesting Agrisystem Module for Farmland Management .....	33

## INTRODUCTION

This paper, prepared<sup>(°)</sup> under the auspices of UNIDO for the Plastics in Agriculture Project CIM-UNIDO, provides a state-of-the-art overview of those plastics products and uses which may have a direct applicability in the northern arid regions. The versatility-availability of many widths, thickness, colors, formulations, and cost-makes them suitable for many applications. Once used primarily in the culture of high income horticulture crops, plastics find wide applications today in agriculture production, marketing and conservation of natural resources. These include greenhouses coverings, solar collectors, mulches, row covers, irrigation, fumigation, drainage, reservoirs, growing containers, grain and silage storage, bulk bins, packaging, coatings, netting, pipes, etc. Specifically, plastics benefit agriculture by increasing crop yields, improving quality, lowering costs, permitting out of season cropping, and improving cultural practices.

Plastic tubing drains agricultural lands and distribute water to growing crops. Plastics films create favorable plant growing environments and provide economic alternatives for conservation of energy and water.

The purpose of this paper is to summarize current utilization of plastics and their potential application for irrigation, greenhouse covering, mulch, and water conservation in arid regions. The data are based on published reports and proceedings of current and projected applications.

(°) September 1981



## PRODUCTS AND USES

The applications and principal kinds of polymers are summarized in Table 1. The applications in Table 1 can be directed to production of food, fiber and ornamental crops.

### Irrigation

Polyethylene and polyvinylchloride are the major kinds of polymers used for pipe. Drip or trickle irrigation systems can be used for row and tree crops. Drip irrigation is a slow, frequent application of water to growing crops to maintain optimum soil moisture in the root zone. It is a water distribution system often operated under low pressure. The advantages of drip irrigation are decreased water usage, good yields, and ability to fertilize through the system (Hall, 1976).

TABLE 1  
USES OF PLASTICS

Application	Kind
Pipe - drainage, water distribution, irrigation	polyethylene polyvinylchloride
Film - mulch, fumigation, greenhouse covering, general farm use	polyethylene
Planters - pots, growing containers	polystyrene, polypropylene, polyethylene
Molded parts - equipment, machinery parts	nylon, polyethylene polypropylene, acetal

(Anon., 1975; Courter and Massey, 1977)

Drip irrigation began in the early 1960s and by 1974 more than 70 companies were manufacturing 50 different systems and components (Gustafson et al., 1974). In 1975 about 250,000 acres worldwide were under drip irrigation. Over half of this world total is located in the United States for irrigation of trees, grapevines, tomatoes, cucumbers, and strawberries (Gustafson, 1976).

Other major applications of drip irrigation include sugar cane, row crops, citrus, nut, and deciduous fruit trees, and greenhouse production of vegetables, potted plants, and flowers. Increase, worldwide, has been projected to 860,000 acres by 1980 (Gustafson, 1976). Various drip and trickle irrigation applications are discussed in a series of proceeding publications published by the National Agricultural Plastics Congress (Bibliography).

#### Management of Trickle Systems

Obtaining high efficiency with trickle or drip irrigation systems depends largely on proper water management and system maintenance. Management not only includes scheduling, but how to adapt cultural practices and apply fertilizers and other chemicals. Bucks, et al. (1980) provided an overview of management and maintenance factors in the arid southwest United States which is given below.

a. Irrigation scheduling: Water application in Arizona with moderately saline water and heavy to medium textured soils has shown that daily irrigation did not improve yields over less frequent applications in cotton, cabbage, cantaloupes, and grapes. Any reduction in water delivery requirements for trickle irrigation over other methods would come from improvement in irrigation efficiency. On-farm irrigation efficiency, expressed as a percentage, usually refers to the ratio of the irrigation water requirement to the total quantity delivered to the field (Jensen, 1973). The irrigation water requirement can also include any water used for other beneficial or necessary purposes; for example, to help germination, provide frost protection or crop cooling, dissolve fertilizers, or enhance product quality. On-farm efficiency for trickle irrigation may range from 20 to 95 percent (Bucks et al., 1980).

b. Cultural Practices: Trickle systems can be installed either above or below the soil surface. For tree crops, all the mains, submains, and lateral lines are normally buried and only the emitter is placed above ground.

For row crops, subsurface trickle offers several practical advantages over surface trickle methods: 1) the subsurface system does not require staking of the trickle tubing during early plant growth to prevent movement caused by wind or sun (expansion and contraction); 2) a subsurface system does not interfere with machine or manual thinning, weeding, spraying, or harvesting; 3) a subsurface system does not require removal or replacement of the tubing between crops; and 4) roots do not clog or plug the subsurface irrigation tubing.

Another possibility for row crops is the traveling or continuous-move trickle system (Rawlings et al., 1974; Wilke, 1974). Numerous manufacturers and researchers are now modifying center-pivot or lateral-move sprinkler systems with plastic drop tubes, low-head sprayers or trickle emitters to reduce energy requirements.

Adaptations of cultural practices to match improved trickle irrigation concepts have not been fully explored. More hedge plantings for tree crops, higher plant populations for row crops, and more use of herbicides through trickle systems instead of conventional cultivation or soil application of herbicides are examples. Minimum tillage practices can be ideal for trickle irrigation. Furthermore, water penetration problems caused by soil compaction may be less of a concern than with other irrigation methods because water application rates are slower and water need not be applied within controlled traffic areas for machinery.

c. Chemical Applications: Chemicals can be injected through a trickle system either to improve crop production or to prevent clogging. Water amendments, such as fertilizers, herbicides, insecticides, and fungicides, can be fed through trickle lines to supply the nutrient needs of plants or to control plant pests. Advantages of this application method are reduced chemical requirements, energy and labor savings, and flexibility in scheduling applications. Water amendments may be supplied to the crop regardless of the plant growth stage or accessibility of machinery to the field.

Water treatments used to prevent or reclaim clogged trickle emitters include acids, algicides, and bactericides. Without water conditioning, individual emitters may vary widely in discharge rate, greatly reducing the distribution uniformity of water and water amendments. Clogging also increases maintenance and replacement costs.

Information and criteria have recently been published on advantages and disadvantages of many chemicals, methods of preparation and injection, rates of application, and plant requirements for trickle irrigation (Bucks and Nakayama, 1980; Rolston et al., 1979).

d. Automation: Trickle systems may be operated manually or automatically. Manually operated systems are turned "on" and "off" by hand. Automation can reduce labor costs, especially if water applications are frequent.

Automating the trickle system is typically less expensive than other irrigation methods, since the basic hardware is simply smaller. Electrical, mechanical, or battery-operated time clocks that signal pumps and solenoid valves are least expensive (Davis and Nelson, 1970). The operator still has to set the time of irrigation. The operator's labor can be further replaced by more sophisticated controllers, which receive scheduling inputs from tensiometers, evaporation pans and other climatic instruments, or precision soil moisture sensors, to initiate irrigations (Busman and Fangmeier, 1979; Phene et al., 1973; Wendt et al., 1973).

#### Maintenance of Trickle Systems

Emitter clogging caused by physical, chemical, or biological contaminants can be a serious problem with trickle irrigation. Major physical factors are suspended silt, clay, fine sand, or plastic particles, as well as plant, animal, and bacterial debris. Chemical factors include the precipitation of calcium or magnesium carbonate, calcium sulfate, iron oxides, and fertilizers dissolved in the water. Biological factors include bacteria and algae that form filaments, slimes, and chemical deposits.

Table 2 is an abbreviated form of a water quality hazard criteria and should be used only as a guide before installing a trickle system. The major contributors to clogging under the physical, chemical and biological factors are rated as slight, moderate, or severe hazards. The sampling dates for water analysis are important, because water quality can vary significantly with time.

Prevention rather than reclamation is the best solution to reducing or eliminating clogging problems. Preventive maintenance includes water filtration,

field inspection, pipeline flushing, and chemical water treatment. Good water filtration and systematic field inspection are both essential. Flushing of trickle lines can also help minimize sediment buildup. Chemical water treatment can improve the long-term performance of the system.

a. Water Filtration: Screen, centrifugal, cartridge, sand, or gravel-packed filters are available. In selecting the type, size, and capacity of the filter, the initial water quality (Wilson, 1972) and emitter design (Solomon, 1977) must be considered. When the physical factors become severe (Table 2), two or more types of filters in series may be needed. As a general rule, filtration units should be designed with at least a 20 percent extra capacity.

b. Field Inspection: Good maintenance requires that filters be cleaned, either automatically or manually, and inspected at least weekly. Operation of chemical injectors, time clocks, pressure regulators, water meters, and the main pump must also be checked and repairs made as necessary. Visual checking for malfunctioning emitters and pipeline leaks in the field should then be completed regularly.

c. Pipeline Flushing: Flushing valves should always be provided at the ends of mains and submains and provisions made for the flushing of lateral lines. Laterals can be flushed either automatically or manually. Automatic flushing should be used where the water is extremely high in silt, clay, or biological residues (McElhoe and Hilton, 1974; Shearer, 1977). A general recommendation is that lines be flushed every six months for tree crops and at the beginning, middle, and end of each season for row crops. When the system is first installed, flushing is needed more frequently to remove initial sediment and plastic particles from all trickle lines.

d. Chemical Water Treatment: Use of chemicals to prevent emitter clogging may not always be necessary. Acids can be added to irrigation water high in pH and salinity (Table 2) to lower the pH and reduce chemical precipitation. The two commonly used chemicals are sulfuric and hydrochloric acid.

Where biological indicators are high (Table 2), calcium or sodium hypochlorite, chlorine gas, or other algicides can be supplied along with the water to control bacterial growth. Chlorination is not recommended for water containing significant

amounts of dissolved iron (Ford and Tucker, 1974). When long-term operation is planned, waters having high levels of iron, manganese, hydrogen sulfide, or bacteria may not be suitable for a trickle system.

TABLE 2  
TENTATIVE CRITERIA FOR CLASSIFYING POTENTIAL CLOGGING HAZARD  
OF IRRIGATION WATERS TO BE USED IN TRICKLE SYSTEMS

Factor	Clogging Hazard		
	Slight	Moderate	Severe
Physical			
Suspended solids (Max. ppm) <sup>a/</sup>	50.0	50-100	100.0
Chemical			
pH	7.0	7.0-8.0	8.0
Dissolved solids (Max. ppm) <sup>a/</sup>	500.0	500-2,000	2,000.0
Manganese (Max. ppm) <sup>a/</sup>	0.1	0.1-1.5	1.5
Iron (Max. ppm) <sup>a/</sup>	0.1	0.1-1.5	1.5
Hydrogen sulfide (Max. ppm) <sup>a/</sup>	0.5	0.5-2.0	2.0
Biological			
Bacteria populations (Max. no/ml) <sup>b/</sup>	10,000.0	10,000-50,000	50,000.0

<sup>a/</sup> Maximum measure concentration from a representative number of water samples using standard procedures for analysis.

<sup>b/</sup> Maximum number of bacteria per milliliter can be obtained from portable field samplers and laboratory analysis.

(Bucks et al., 1980)

## Comparison of Irrigation Systems

Specific characteristics of surface, sprinkler, and drip systems are compared in Table 3. Drip has several advantages and disadvantages as listed below.

### a. Advantages of Drip Irrigation

- Highest water use efficiency (80 percent to 90 percent).
- Effective on all soils.
- Effective on all topography.
- Low energy requirements compared to sprinklers.

### b. Constraints of Drip Irrigation

- Highest initial cost of any alternative system plus high maintenance costs.
- Emitter clogging problems.
- High supervision requirements.
- Deterioration of parts and need to replace them.
- Soil-water chemistry problems.

TABLE 3

COMPARISON OF IRRIGATION SYSTEMS<sup>1</sup>

Site and Situation Factors	Traditional Surface Systems	ALTERNATIVE SYSTEMS						
		Improved Surface Systems			Sprinkler Systems		Drip Systems	
		Redesigned Surface Systems	Level Basins	Intermittent Mechanical Move	Continuous Mechanical Move	Solid Set and Permanent	Emitters and Porous Tubes	Sublerters and Splitters
Soil	Uniform soils with moderate to low infiltration	Uniform soils with moderate to low infiltration	Uniform soils with moderate to low infiltration	All	Sandy or high infiltration rate soils	All	All	All - basin required for medium and low intake soils
Topography	Moderate slopes	Moderate slopes	Small slopes	Level to rolling	Level to rolling	Level to rolling	All	All
Crops	All	All	All	Generally shorter crops	All but trees	All	High value required	High value required
Water supply	Large streams	Large streams	Very large streams	Small streams nearly continuous	Small streams nearly continuous	Small streams	Small streams, continuous and clean	Small, streams continuous
Water quality	All but very high salts	All but very high salts	All	Salty water may harm plants	Salty water may harm plants	Salty water may harm plants	All - can potentially use high salt waters	All - can potentially use high salt waters
Efficiency	Average 60%	Average 60-70%	Average 80%	Average 70-80%	Average 80%	Average 70-80%	Average 80-90%	Average 80-90%
Labor Requirement	Moderate to high training	High, training required	Low, some training	Moderate, some training	Low, some training	Low to seasonal high, little training	Low to high, some training	Low, little training
Capital requirement <sup>2</sup>	-	\$50 to \$100 per acre plus water supply	\$100 to \$200 per acre plus water supply	\$100 to \$200 per acre plus water supply	\$200 and up per acre plus water supply	\$500 and up per acre plus water supply	\$500 and up per acre plus water supply	\$550 and up per acre plus water supply
Energy requirement	Low	Low	Low	Moderate to high	Moderate to high	Moderate	Low to moderate	Low
Management Skill	Low to moderate	Moderate	Moderate	Moderate	Moderate to high	Moderate	High	High
Machinery operations	Medium to long fields	Medium to long fields	Short fields	Medium field length, small interference	Some interference circular fields	Some interference	May have considerable interference	Some interference
Duration of use	Short to long	Short to long	Long	Short to medium	Short to medium	Long term	Long term, but durability unknown	Long term
Weather	All	All	All	Poor in windy conditions	Better in windy conditions than other sprinklers	Windy conditions reduce performance, good for cooling	All	All
Chemical Application	Fair	Fair	Good	Good	Good	Good	Very good	Very good

<sup>1</sup> Adapted from Fangmeier, D.D., 1977, Alternative Irrigation Systems

<sup>2</sup> Cost in 1977



## Greenhouses and Greenhouse Production

Greenhouse construction generally uses 4 or 6 mil UV light-stabilized polyethylene and/or Fiberglass-Reinforced-Plastic (FRP) panels (Courter, 1976; Hartman, 1977). Some polyvinylchloride, polyester, and polyvinylfluoride films are also used.

The low cost of polyethylene, wide widths and good handling characteristics have made this plastic a popular, but temporary, covering material for greenhouses. FRP panels are more permanent and offer storm protection.

The versatility of plastic allows its use to conserve greenhouse energy. Double-layer construction with an airspace between layers provides insulation to save fuel and reduce condensation (Roberts, 1975). Recent developments also include injection of insulating foam between layers of film (Jensen, 1977a). Plastics can also be utilized to collect solar energy and to distribute heated water by drip tubes over plastic heat exchangers (Roberts et al., 1976).

Other uses of plastics in greenhouses include tubes for fresh air and heat distribution, irrigation lines, shade cloth protection, winter storage of nursery feedstock, and mulch for potted plants (Proceedings, National Agricultural Plastics Conference 1969, 1971, 1973, 1975).

A recent innovation is the nutrient-film technique (NFT) where vegetables are grown with roots fed nutrient solutions inside film tubing without soil or other root medium (Anon., 1976).

Mexico's use of the latest technological improvements has increased greenhouse vegetable production for U.S. export up to 350 tons per year.

### University of Arizona Approach to Controlled Environment Agriculture (CEA)

In the mid-1960s, the Environmental Research Laboratory (ERL) of the University of Arizona began extensive research in the development of intensive food production systems for desert regions of the world. The initial research, conducted by the Universities of Arizona and Sonora, Mexico, was in growing of vegetables in

controlled-environment, air-inflated greenhouses. The experimental unit was located in Puerto Penasco, Sonora, Mexico (Hodges and Hodge, 1971; Jensen and Teran, 1971) on the east coast of the Sea of Cortes. The goal in Mexico was to find economical means of using expensive desalted water and, at the same time, to make a coastal desert agriculturally productive. The results of the research at Puerto Penasco led to the establishment of controlled-environment agricultural facilities at the Arid Lands Research Center in the country of Abu Dhabi and Kharg Environmental Farms on Kharg Island in Iran (Jensen and Eisa, 1972).

a. Water Conservation: Conservation of freshwater and the production of high-quality vegetables at yields greater than outdoor agriculture are the prime reasons for growing crops in a controlled environment.

In the desert areas of Mexico and the southwestern United States, supplies of freshwater are limited or are rapidly being depleted by the use of present agricultural methods.

The amount of irrigation water needed to yield one kilogram of edible product is shown in Table 4. The figures listed under CEA were derived from a greenhouse where seawater or brackish water was used in summer cooling.

TABLE 4  
WATER CONSUMPTION — CONTROLLED-ENVIRONMENT VERSUS  
OPEN-FIELD AGRICULTURE

Vegetable	Liters of Irrigation Water/Kilo of Edible Product	
	Controlled-Environment Agriculture	Open Field
Cucumber	10	205
Lettuce	3	96
Tomato	13	123

(Jensen, 1977)

b. Yields: Higher yields may be attributed in part to the more ideal growing conditions within the greenhouse. In some cases, the harvest periods are longer than those in the field. In addition, vine crops, such as tomatoes and cucumbers, utilize much of the three-dimensional greenhouse space available, and production figures are high when such use of total volume is practiced. Because the environment is mostly controlled, crops can be grown year-round, despite outside high or low temperatures. Therefore, fresh, high-quality vegetables can be made available constantly, while those vegetables grown in outside fields may be seasonal or expensive.

Table 5 lists varieties and yields of vegetable crops grown in Abu Dhabi.

TABLE 5  
YIELD OF CROPS GROWN IN ABU DHABI GREENHOUSES (TONS/HA)

Type of Vegetable	Variety	Yield/ Crop (T/ha)	Crops/ Year	Total Yield (Tons/Ha/ Year)
Broccoli	Hybrid No. 5	32.5	3	97.5
Bush Beans	Green crop	11.5	4	46.0
Cabbage	Exp. Cross 60	57.5	3	172.0
Chinese cabbage	Tropicana	50.0	4	200.0
Cucumber	Femfrance	175.0	3	525.0
Eggplant	Jersey king	28.0	2	56.0
Pepper	New Ace	32.5	2	97.5
Tomato	N-65	150.0	2	300.0

(Jensen, 1977)

c. Energy Needs: A concern in the United States has been the uncertainty of energy availability and/or the cost of energy to control the growing environment. While the controlled-environment greenhouse produces food crops out of season at yields often far greater than those obtained outdoors, it is also a great user of energy (Table 6). Because of the abundant energy supplies in Mexico, this constraint may not be as important in Mexico as in the United States.

The energy inputs for cultivation, fertilizers, pesticides and irrigation are nearly equal for both greenhouse and open-field agriculture, but control over the environment within a greenhouse may require large amounts of energy.

TABLE 6  
COMPARATIVE YIELDS AND ENERGY USAGE FOR VEGETABLES  
GROWN IN GREENHOUSES VERSUS FIELD GROWN

Type of Vegetable	Field Grown		Greenhouse Grown			
	Tons/ha/yr	Energy input Kcal/kg	Tons/ha/crop	Crops/yr	Total tons/ha/yr	Energy input Kcal/kg
Cucumber	30	552	175	3	525	6,855
Tomato	75	220	150	2	300	11,997

(Jensen, 1977)

In northern latitudes, most of the energy used in greenhouses is in the form of fossil fuel to heat the environment, while in southern latitudes, the energy, in the form of electricity, is for fan and evaporative cooling. Environmental control costs are usually less in the southern regions.

Much of the heat is lost through radiation and conduction out of the greenhouse during the night. However, methods to prevent 50 to 75 percent nighttime heat loss from a greenhouse are being developed. Such insulation systems are made of reflective materials or liquid foam (Jensen, 1977b). Natural ventilation systems requiring little or no energy will no doubt be designed into future installations so that evaporative cooling will only be used when absolutely needed. While such ventilation systems would not lower capital investment, they should enable lower operational or electrical costs.

The two major alternative heat sources for controlled-environment agriculture are solar energy and rejected heat from large industrial units. For every kilowatt-hour of electric energy produced, the electric generating industry rejects the equivalent of nearly two kilowatt-hours of heat to cooling the water. Enough heat

exists in the condenser water discharge of many electric generating units to heat hundreds of hectares of greenhouses. Systems now being tested can economically extract heat energy from low temperature reject water of large electric power stations (Burns et al., 1976). The present economics of using waste heat from generating plants favors incorporating the heat-use system into the overall plans for design of new plants rather than modifying existing ones.

## Mulch

Plastic mulching - the application of film over the soil and plant roots and under plant foliage and fruit to modify plant environment - conserves soil moisture, modifies soil temperatures, reduces fertilizer leaching, improves soil structure, and controls weeds. The benefits are improved plant growth, cleaner fruit, earliness, and larger yields (Hopen and Obeker, 1976).

### Mulch Installation

Smith (1968) provided guidelines for an effective mulching system and field layout which are given below:

- Apply fertilizer by soil test in sufficient quantity for the growing season, as it is difficult to add fertilizer during the growing season.
- Treat the soil for such things as nematodes, cutworms, borers, and soil-borne diseases, as these survive under the mulch and are difficult to control once the mulch is down.
- Select the size of the bed on the basis of local horticultural needs as affected by the source of water and the ability of the soil to have water move laterally through it. If rainfall is the primary source of water to the plants, there is no regular control over the soaking time to allow water to travel laterally. Therefore, the seed beds should be no wider than that which would allow lateral movement of water to the center of the bed during a typical low rainfall.
- List the fields as far in advance of bed formation as is possible. This reduces the work load at the time of mulching and helps a good moisture profile to develop in the beds.
- The condition of the soil in the beds should be fine, free from large clumps, mud clots, and excessively large rocks which would prevent the mulch from lying directly on the soil surface.

- Shape the beds with a slight crown in the center to permit water run-off and to prevent puddle formation on the mulch.
- Compact the soil so as to prevent soil settling after the mulch is laid; otherwise weeds may germinate in the airspace.
- Apply a herbicide at the backfill soil line as the mulch is laid down to prevent weed germination and competition with the crop.
- Assure that the soil is damp when the mulch is applied so that there is sufficient moisture under the mulch. Dry soil should not be mulched unless there is ample irrigation water available to soak the beds after mulching. Water must be available to seeds and it is best to have it there before mulch is laid.
- Assure that the mulch is snug and directly on the surface of the bed to prevent weed growth under the mulch.
- If the mulch is walked upon shortly after application, there will be a tendency to cake the soil underneath and for water to puddle on the mulch surface.
- Seeding or transplanting is done three or more days after laying the mulch. This allows the mulch time to stabilize and reduces possible shifting of the mulch over the plant.
- Holes should be cut in the mulch either with a hand tool or with planting machinery. Rounded holes reduce tearing of the mulch by the wind.
- Watering after the mulch operation is accomplished by soaking the soil between the rows of mulch or with sprinklers.
- Mulch should be left down until harvest time.

## Principles, Practices, and Problems

Schales (1973) discussed the principles, practices, and problems involved in using plastic mulches for vegetable production from a grower's perspective. He considered 12 factors which revolve around the presumed fact that a ready market for high quality produce is available.

- How will mulching fit into the overall situation with regard to soil type, crop selection, mulch type, transplanting or direct seeding, crop rotation, water availability, wind breaks, and weed control.
- High quality, high yielding varieties of crops should be used.
- Light textured soils dry out and warm up faster in the spring than heavier soils. Also, land sloping toward the south absorbs more heat from the sun early in the spring than north facing slopes. Land to be mulched should be plowed, dished, and dragged to a smooth clod-free surface. All anticipated fertilizer requirements should be incorporated at this time.
- The kind of plastic to use — clear or black — will depend on each situation. Clear plastic will result in higher soil temperature than black, which generally will result in higher yields of cantaloupe, cucumber, and summer squash. However, if clear plastic is used, a suitable means of weed control under the film is essential.
- Mulch application on well-prepared land is important. Soil moisture should approach field capacity, but soil should not be too wet to till. The film should be applied so the edges are turned nearly straight down, then turned up slightly so the backfill and soil will anchor the film in place.
- A critical weed problem often develops soon after holes are punched in the mulch for transplanting or seeding the crop. These weeds should be hand pulled while small. If allowed to grow very large, pulling them out will damage the roots of the crop plants.



- If the crop is direct seeded, the seeding rate should be sufficient to assure a good stand. Extra plants may be hand picked after germination.
- Where transplants are used, make sure they are healthy, vigorous, and free of insects and disease. Tomato plants should not have any fruit set at the time of transplanting. Cantaloupe and cucumber plants should be about three weeks old, with the first true leaf about two inches in diameter.
- A starter solution made up by dissolving three pounds of 10-52-17 or other high phosphorous water soluble fertilizer per 50 gallons of water, applied at the rate of one-half to one pint per plant at transplanting time is beneficial.
- Supplemental irrigation is often required. Even though the mulch helps control water, plant growth is often considerably greater on the mulch, resulting in greater water requirements by the crop.
- At the end of the harvest the grower is faced with the problem of removing the film. Normal clear or black polyethylene films will not degrade sufficiently to allow satisfactory incorporation into the soil. Several techniques have been used to remove the film. Freezing weather will kill the plants allowing hand removal. The plants can also be sprayed (one quart Paraquat in 50 gallons of water per acre), mowed, then dug up with the plastic.
- Future mulches will be degradable, making it possible to incorporate them into the soil with no residue. Research and test results are becoming available on this technology (Titus, 1973).

#### Mulching Technique for Arid Lands Vegetable Production

Obeker, Peebles, and Cluff (1971) initiated a project to test the use of plastic aprons as a mulch to grow horticultural crops on a minimal supply of water in an arid area.

The plastic aprons were made of vinyl, six mils in thickness and approximately one meter square. Plots were prepared for individual plants by excavating a shallow basin using a vee-shaped sweep on a posthole digger attached to a tractor. The basins were about three feet in diameter with five percent side slopes.

The plastic aprons were anchored by covering the edges with soil at the rim of the basin. The aprons are constructed with holes in the center or bottom of the cone. These holes are covered with an attached piece of plastic in such a way that the rainwater was funneled beneath the plastic apron, but evaporation is inhibited due to the cover over the holes. A light gray gravel varying in size from 3/16 to 5/8 inches was used on the gravel plots. It was applied to a depth of about 1.5 inches.

Results indicate the value of gravel and plastic mulches in conserving water for growth of horticultural crops.

Plants with the plastic mulch required slightly less water than the plants with the gravel mulch. Prior to the frost in the fall of 1969, the plastic-apron-covered lots required only 12 gallons of water or 1.8 inches of water. It was much easier to achieve germination on the plots where the mulches were used. The effectiveness of the gravel might be enhanced by using a smaller particle size or increasing total gravel applied. Table 7 shows squash production for the 1969 and 1970 fall plantings. Plastic and gravel plots yielded significantly better than bare plots.

The use of plastic aprons and gravel mulch appears to be a worthwhile method of conserving water in crop production. The plastic apron has an additional advantage in that it also collects and diverts rainfall to the plant. Where the mulch is to be supplied without cost to the farmer, plastic represents the most convenient material from an application point of view. The vinyl used in the tests lasted only two seasons, but more durable materials are being evaluated. The capital investment required to obtain a gravel mulch would be relatively low. This would be an advantage in developing countries where capital is scarce. Since gravel is unaffected by ultraviolet induced oxidation, it has an unlimited life providing the gravel particles are large enough so that they can be regenerated by screening. This regeneration would be needed following each planting to assure an effective mulch.

TABLE 7  
SQUASH YIELD FOR TREATMENTS USED  
IN PLANTINGS, 1969 AND 1970\*

	Plastic Covered Fruit		Gravel Covered Fruit		Bare Soil Fruit	
	No.	Wt. (gms.)	No.	Wt. (gms.)	No.	Wt. (gms.)
<u>Fall 1969</u>						
Level 1**	18.5	1,560	—	—	0	—
Level 2	33.0	2,529	8.2	534	0	—
<u>Fall 1970</u>						
Level 1	34.5	7,718	27.7	6,311	22.2	4,367

\* Average number and weight of fruit produced by five plants.

\*\* Two supplemental irrigations plus rainfall, one rainfall only.

## Water Conservation

Polyethylene, polyvinylchloride, and butyl rubber films line ponds, canals, and water reservoirs and form water catchments (harvesting) in semiarid areas. This chapter limits discussion to water catchments and water storage alternatives for semiarid applications.

### Water Catchment Methods

Cluff (1981) reviewed various methods of water catchments and cost. These methods vary in simplicity and cost, and are presented here for comparative purposes with gravel covered plastic (Table 8).

a. Compacted Earth: This is the simplest treatment. It consists of shaping the land into a series of troughs and ridges using a road grader. Generally, a five percent slope would be used with trough depression every 50 feet. Thus, a four-inch cut would be made to form the trough and a four-inch fill would be made to form the ridge. On cleared farmland a grader should be able to complete an acre every two hours. By equipping the grader with a laser, excellent slope control could be achieved.

After the catchment is shaped with a grader and smoothed using a rotary rock rake, it is compacted following a natural rainstorm. Low efficiency and high weed growth are the two limiting features of the compacted earth.

b. Salt Treated Compacted Earth: The addition of five tons per acre of sodium chloride to a compacted earth catchment prior to compaction greatly increases the efficiency and reduces weed growth dramatically. It also eliminates the need for a reservoir liner in most soil types. The water from a salt-treated catchment is of excellent quality, generally lower than 200 ppm dissolved solids. It will carry dispersed clay, making coagulation and filtration necessary prior to domestic or industrial use.

This method is particularly well suited for direct agricultural uses. The land can be readily reclaimed at any time by disking or plowing the catchment area.

TABLE 3  
1981 COST ESTIMATES\* OF DIFFERENT WATER HARVESTING METHODS

	\$ Acre	Efficiency	Expected Life/Yrs.
1. Compacted Earth	110	15 - 20	3 - 5
2. Compacted Earth Sodium Treated	300	40 - 60	10 - 15
3. Gravel Covered Plastic	2,200	60 - 80	30 - 40
4. Wax Treated	2,650	80 - 90	5 - 10
5. Fiberglass Asphalt Chipcoated	4,925	85 - 95	15 - 20
6. Asphalt Rubber Chipcoated	5,460	85 - 95	20 - 25
7. Polypropylene Reinforced Mortar Covered Plastic	11,400	90 - 95	50 - 60

\* Cost and efficiency estimates are based on installing a 40-acre system on retired farmland in southern Arizona.

c. Gravel Covered Plastic: This treatment would start with a salt-treated, compacted earth treatment, then a six-mil polyethylene liner covered with gravel would be installed, using a plastic dispensing self-propelled chip spreader. This treatment provides water of excellent quality for all types of uses. It could be used directly for domestic use with very little treatment. Cluff (1971) reported the results of experiments begun in 1965 with a gravel-covered plastic. An 8' X 16' experimental plot was established in 1965 which consisted of six-mil black polyethylene plastic covered with a one-inch layer of gravel (3/16 inch to 3/8 inch diameter). From December 1965 to December 1970, 192 separate rainfall events were recorded totaling almost 60 inches. On 113 of the 192 recorded events, runoff was obtained for a total of 45 inches or 75 percent of the rainfall. A control plot during the same periods produced runoff only during 33 storms, representing a total of 10.5 inches, or 17.6 percent of the rainfall.

Catchment sites can usually be selected so that slopes will be less than 15 percent and the length shorter than 200 feet. Therefore, a gravel mixture with diameters ranging from 3/16" to 1/2" will normally be adequate. The ideal gradation of gravel sized within this range is that which will maximize the density of the cover.

In order to reduce installation costs of larger catchments where imported gravel is used, a plastic laying gravel spreader was developed and first tested by installing a half-acre gravel covered plastic catchment at the Water Resources Research Center (WRRC) Field Laboratory, Tucson, Arizona. The imported gravel was dispensed from a dump truck into a standard spreader box before dropping onto a slide. A schematic diagram of this dispenser is shown in Figure 1.

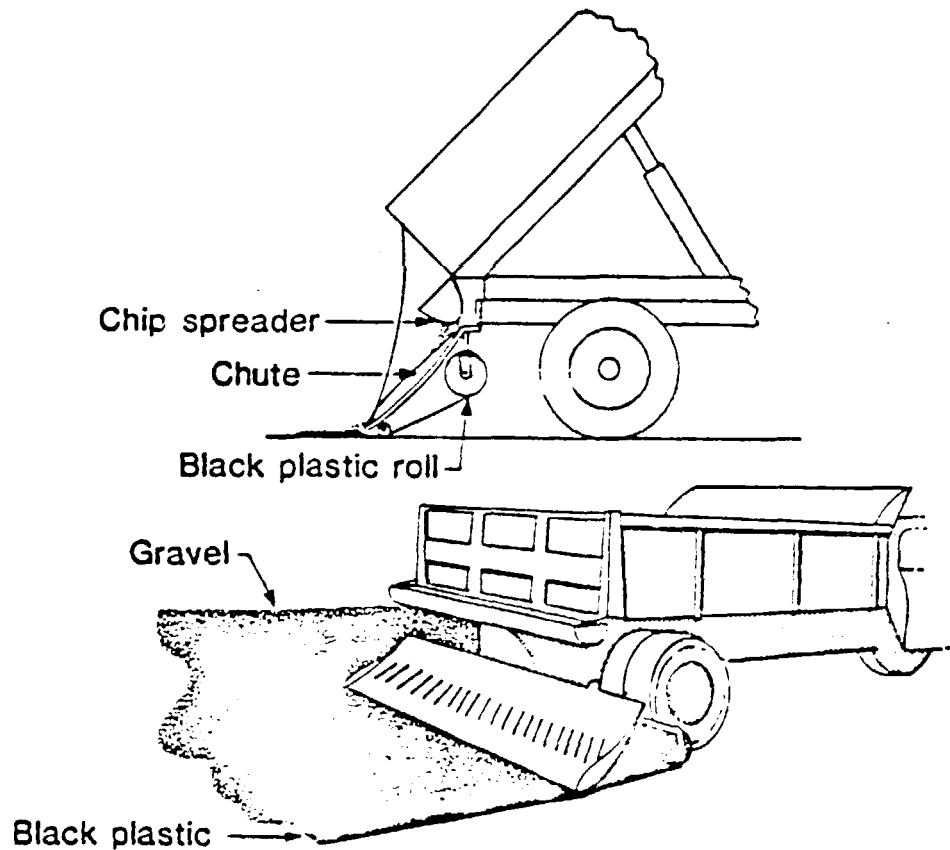

Figure 1  
PLASTIC LAYING GRAVEL SPREADER

(After Cluff, 1971)

Plastic was dispensed under a roller on the lower part of the slide. Four-mil black polyethylene was used in the construction of this plot. There was some damage when this thickness of plastic was used in the installation process. Improvement in the chute and the use of plastic in thicknesses greater than four-mil in recent installations have greatly reduced this damage. Side slopes on the catchment were five percent. Integration of the plastic was accomplished with a 6" overlap.

This plastic dispenser has also been used in installation of seepage membranes (Cluff, 1963). When installing a reservoir liner a suitable earth cover material is used instead of the gravel. Overlaps are left exposed until seamed. With polyvinylchloride plastic the normal solvent-type sealant is used.

For projects involving catchments or reservoirs larger than two acres, a modified self-propelled chip spreader was proposed. A schematic diagram of this method of dispensing is shown in Figure 2. A 12' to 15' strip of plastic could be laid down in a single pass. This method of installation of graveled plastic catchments and plastic liners, although untested at the present time, should provide an essentially trouble-free mechanized system of installing and covering a plastic membrane in a single operation.

Most of the present use of water harvesting systems is for stock and wildlife purposes, usually located in remote areas away from processed gravel sources. The cost of hauling gravel to these remote sites is commonly prohibitive.

In order to reduce further the installation costs of the graveled plastic catchment at such remote sites, equipment has been developed at the University of Arizona which will extract naturally occurring gravel from the soil profile, lay plastic and cover the plastic with the extracted rock in one operation. A schematic drawing of this machine is shown in Figure 3. Although many improvements need to be made, the Gravel Extracting Soil Sifter (GESS) has shown that graveled plastic catchments can be inexpensively installed in this manner in areas containing sufficient rock in the upper three or four inches of soil.

A vibrating screen manufactured by the Link Belt Company has been used in the construction of the GESS to separate the rock from the soil. The soil is elevated

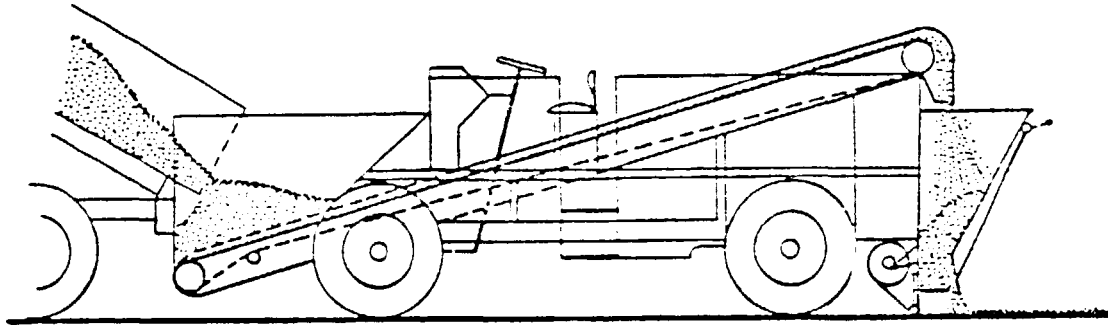

Figure 2  
PROPOSED MODIFICATION OF CHIP SPREADER FOR INSTALLATION  
OF PLASTIC MEMBRANES

(After Cluff, 1971)

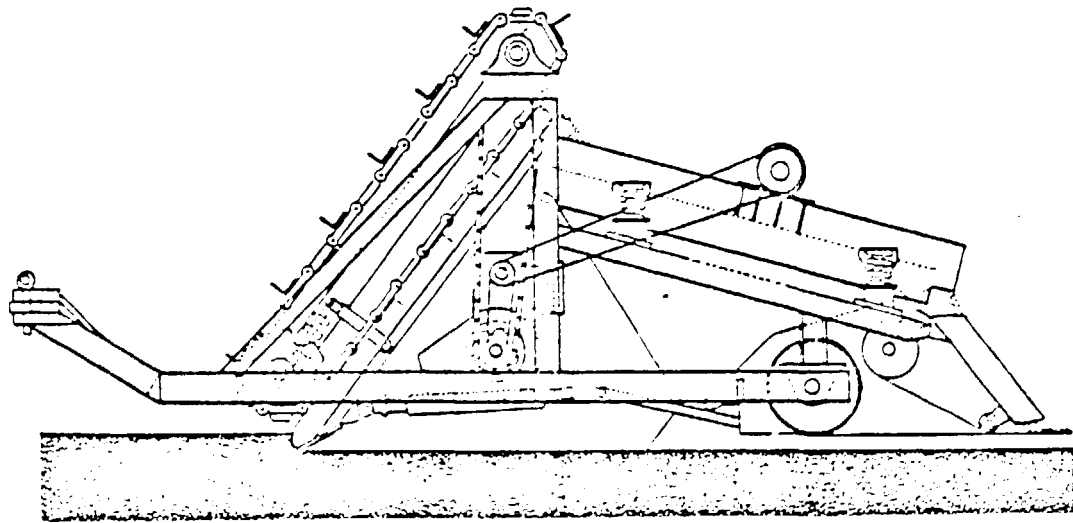

Figure 3  
GRAVEL EXTRACTING SOIL SIFTER

(After Cluff, 1971)



to the screen by means of a cutting blade and an elevating ladder. The fine material is bladed and rolled to provide a smooth base on which the plastic is laid before covering with rock. The separation of gravel from soil is generally made at 3/16 inch. The GESS was constructed to work on essentially rough cleared desert land and to handle rock up to 12" in size. In order to reduce the size of the GESS, it is planned to build the second model to work only on prepared soil where the larger rock has been removed.

One of the biggest cost factors in a water harvesting system is the storage of the collected precipitation. Evaporation and seepage losses must be held to a minimum in order to assure a firm water supply. Seepage can be economically controlled through covered plastic liners. Evaporation is much more difficult to control. Three basic techniques for evaporation control are being tested. These are: floating styrofoam rafts, suspended reinforced butyl rubber and butyl coated polypropylene covers, and rock-filled tanks (Cluff, 1967; Cluff, 1968).

The floating styrofoam rafts achieve 100 percent evaporation control for the area covered. They can be used on any size of reservoir. The rafts are kept on water by means of an "F" shaped extruded plastic edging, which causes a negative pressure to be formed under the raft when an attempt is made to remove it. The styrofoam is protected from weathering with sprayable butyl rubber.

The suspended reinforced butyl rubber and butyl-coated polypropylene covers are limited to smaller tanks with widths of less than 30 or 40 feet. Both aluminum tubes and, more recently, cable suspension have been used.

The rock-filled tank is primarily suited for smaller tanks with less than 50,000 gallons net capacity. This system of storage is particularly compatible with the graveled plastic catchment. The larger rock, in excess of one-inch diameter, in a catchment site can be collected first, using a commercial rock picker, and can be used in the tank. The smaller rock can be used on the catchment. The rock collected by the rock picker is placed in the previously excavated and lined tank to reduce evaporation losses and prevent vandalism. The rock reduces storage capacity by approximately 50 percent, but the above advantages should more than offset this disadvantage.

The key to the successful construction of a plastic-lined and rock-filled tank is the use of a layer of used rubber tires directly on the plastic with the interspace between tires and in the centers of the tires being filled with the fine material. This layer of used rubber tires and fine soil forms a protective cover that essentially eliminates any damage to the plastic when rocks are dumped in the tank. Even if some damage to the plastic occurs with the soil placed over the plastic, tests have shown that seepage loss is insignificant.

d. Wax Treated: This treatment would be made after a compacted earth treatment had been made. Wax is applied molten, using an asphalt boot truck. The wax treatment should be made in the summer when the summer sun will remelt the wax and cause it to move into the soil profile. This treatment was developed at the U.S. Water Conservation Lab in Tempe, Arizona. It works well on some soils but does poorly on others, so it would have to be tried only on a small-scale on soils before treating large areas.

Water from wax-treated soils would be of high quality. It would have some sediment that would have to be removed before it could be used for domestic purposes.

e. Fiberglass Asphalt Chipcoated (FAC): A high-efficiency, long-lasting treatment which is suitable for most soil types. This treatment was pioneered at the University of Arizona. It differs from earlier work done at the Water Conservation Lab in Tempe, where a heavier fiberglass was used and the catchments were not chipcoated.

A relatively thin (10 mil) fiberglass matting is used to reduce costs. The fabric is dispensed using a roller mounted just ahead of a spray bar on an asphalt boot truck. Asphalt is sprayed through the material, bonding it to the ground to form a reinforced asphalt membrane. This membrane is then covered with a layer of 3/16 to 3/8 gravel chips, utilizing gravel spreaders on the back of dump trucks. The treatment will support occasional light vehicular traffic in contrast to gravel covered plastic, which should not be driven on.

The water will have some oxidation products from asphalt that would need to be filtered using a charcoal filter. There would be relatively little sediment.

The largest application of this treatment was on a nine-acre area near Black Mesa, Arizona. This is probably the largest impervious catchment for harvesting water outside of Australia, where several towns are using water from asphalt concrete water harvesting systems.

f. Asphalt-Rubber Chipcoated (ARC): This method was also first used at the University of Arizona. About four years ago, three experimental 8' X 16' plots were installed using 0.5 gal asphalt/yd<sup>2</sup>. Two of the three plots were chipcoated; the third was coated with sand. The sand coating has eroded but the underlying material is in good condition. The chipcoated treatments are working very well.

The process consists of pulverizing used rubber tires and mixing this into asphalt at a high temperature of 350°F. About 25 percent of the asphalt-rubber mixture is rubber.

Although no larger scale water harvesting catchments have been installed using the system, it has been used for seepage control. The material has been selected to line a 250-acre pond at the Palo Verde Nuclear Plant near Phoenix, Arizona.

The water quality from this type of catchment should be about the same as the FAC catchment. The material costs are higher but it is easier to lay down since no fabric is needed and the pulverized rubber provides the reinforcement. The membrane remains flexible so that it can be placed on most soil types, including expansive clay.

#### Water Storage Methods

Collecting water from a controlled water catchment reduces spillway and sedimentation problems generally associated with storage of water in a semiarid environment. However, there still remains a seepage and evaporation problem that needs to be addressed.

Seepage can be controlled using various methods, including those used for catchments as shown in Table 8. As indicated above, if a salt treatment is used on the catchment a reservoir system would be self-sealing. For the impervious

treatments the reservoir would have to be lined unless seepage could be recovered by pumping from the groundwater aquifer. In Avra Valley most of the seepage from a large reservoir system could be recovered. Thus surface ponds could be unlined; only evaporation would need to be controlled.

Evaporation could be greatly reduced by using compartmented reservoirs where the water is concentrated in the smallest number of compartments to reduce surface area (Cluff, 1977). Three to four compartments per reservoir system would be recommended for a 40-acre size water harvesting system. If a higher storage efficiency were needed, the "last" one or two compartments would be protected with a floating cover, or perhaps a floating solar collector which would be used to furnish both electrical and thermal energy to a development. A computerized model has been developed to optimize the design of the compartmented reservoir system.

## Water Harvesting Systems

This chapter is devoted to various applications of water harvesting which could be integrated into existing or future land use. The ideas discussed here could provide suitable demonstration projects at various locations in northern Mexico.

### Water Harvesting Agrisystems

The basic approach used is a shaped catchment with plantings in the drainage-ways. This has been demonstrated at Page Ranch, Arizona (Mielke and Dutt, 1980; Dutt and McCreary, 1974). Farmland will be shaped using a road grader into a ridge and flattened configuration, as indicated in Figure 4. The ridged areas would be treated to shed rainwater onto the adjacent flat lands, which could be planted to various range grasses, agronomy-type crops, high-valued horticultural crops, as well as jojoba, guayule, and buffalo gourds. Excess water will be collected and stored in a covered or compartmented reservoir to irrigate the plants during the dry season.

The width of catchment area to planted area would be varied, depending on the crop. One set of configurations is shown in Figure 4. Some of the factors involved are the type of plant, use of water by the plant, and aesthetic considerations. Other constraints are the width of equipment used during construction and subsequent cultivation and harvesting. The row crop should have a minimum planted width of approximately 12 feet to allow for the use of four-row planting, cultivating, and harvesting equipment. In addition to grazing, other harvesting methods for range grasses could be used. These would consist of cutting and baling, or green chopping for feedlot feeding. The catchment to planted area ratio, as indicated in Figure 4, could be increased to maximize water production for domestic use, recharge to groundwater, establishment of a fishery, or other recreational use.

Water harvesting plots should be established over 40 acres to: 1) determine prices; 2) determine efficiency and water quality of the two catchment treatments; and 3) demonstrate the utility and aesthetics of the system. The emphasis should be placed on the establishment of range grasses, desert oil plants, buffalo gourd,

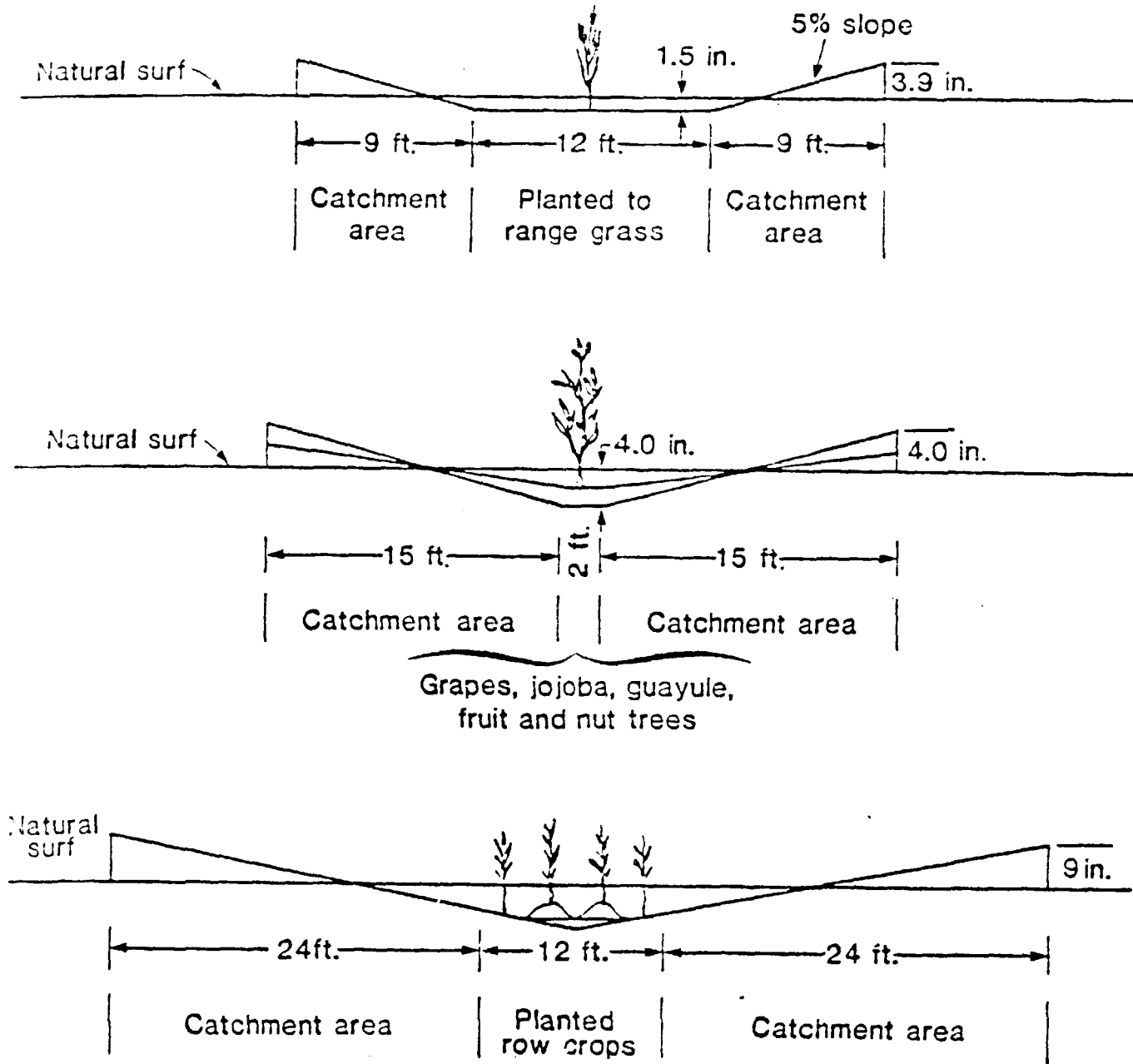

Figure 4  
 SHAPE OF PROPOSED CATCHMENT SYSTEMS

After Cluff (1931)

guayule, jojoba, and agronomy crops. With the exception of jojoba and guayule, production data could be obtained in a two-year period.

a. Rainfed Urban. Rainfall from land could provide water for five to six people per acre based upon Tucson, Arizona's present water use of 140 gallons/person/day or 51,100 gallons/person/year. Water harvesting could support a population's domestic requirements. Rooftops, parking lots, driveways and roads could all feed into an in situ water harvesting system. In addition, open areas could be treated to shed water. The treatment selected for open areas might be one of those indicated in Table 8, coupled with vegetation to improve the aesthetics. The gravel covered plastic on chipcoated asphalt should be very acceptable as a landscape treatment interspersed with vegetation. The reinforced mortar coated surfaces would be very durable and could also be tinted to a soil tone or other color to fit any landscaping decor.

An alternate method of development would be to establish small farms of various sizes that would be supported using water harvesting. These farms could be set up as individual units or in modules as shown in Figure 5. Each module would be operated by the families living thereon, and would be as self-sufficient as practical.

The module, as illustrated in Figure 5, would contain a 70-acre desert landscape area. This buffer area would allow for the passage of floodwaters and serve as a habitat for small game, in addition to maintaining the island-type identity of each module. Further protection of homes from floodwaters could be obtained by building on the excavated soil for the storage reservoir. The inner area under the plan outlined in Figure 5 would consist of approximately 90 acres, divided up into 10-acre areas, where a variety of crops would be grown.

b. Rainfed Industry. The WRRRC and the Office of Arid Lands, University of Arizona, have studied the use of water harvesting in conjunction with the construction of a manufacturing plant east of Tucson, Arizona.

It was found that rainfall, harvested by using rooftops and parking lots, and stored in a compartmented reservoir system would be adequate to support the planned vegetation on the plant site, including grassed recreation areas. By

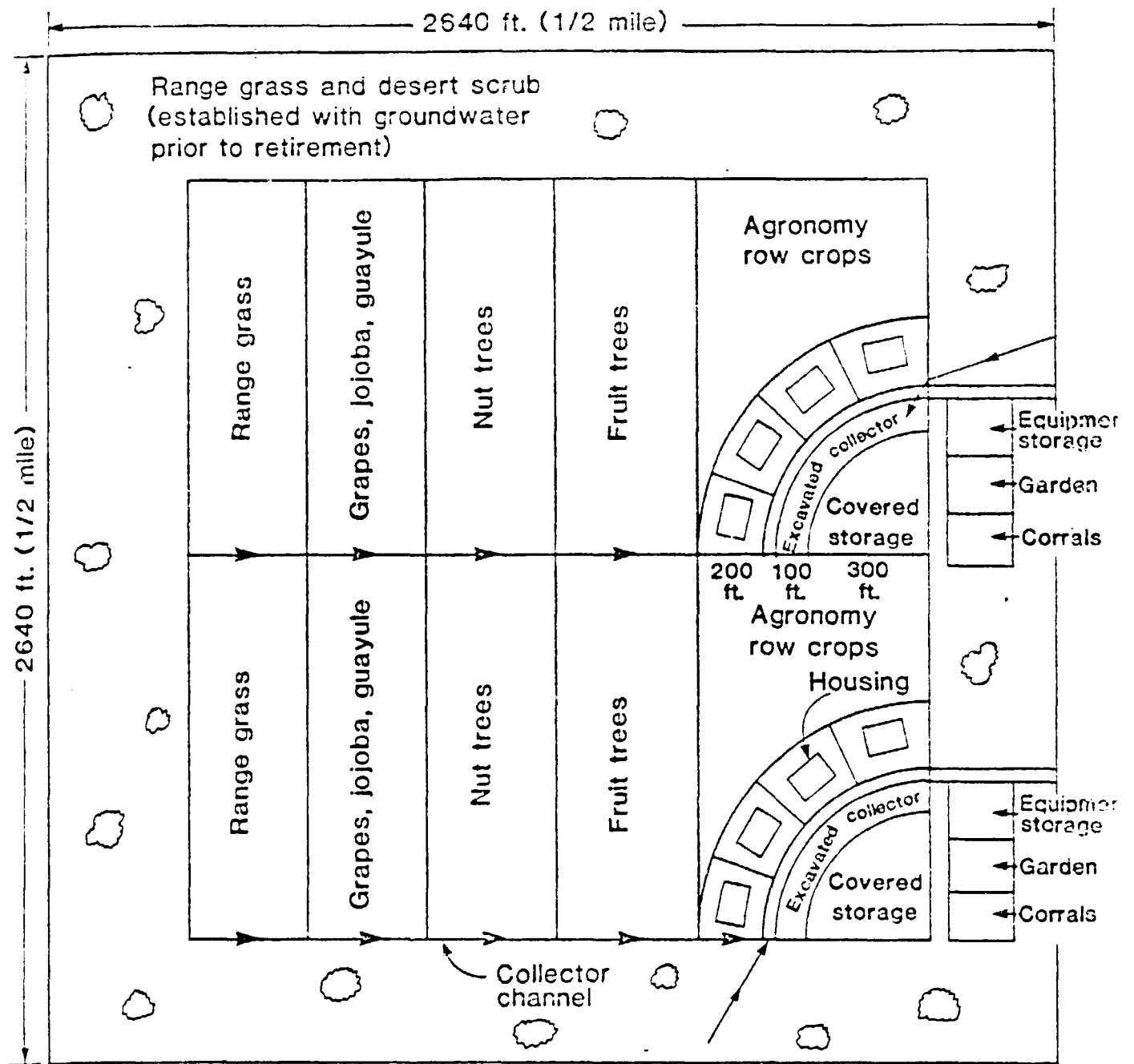

Figure 5  
 WATER HARVESTING AGRISYSTEM MODULE FOR  
 FARMLAND MANAGEMENT

(After Cluff, 1981)



modifying the landscaped area, water harvesting could be used to provide 100 percent of all the water needed in the plant. The groundwater basin could be used for the storage, provided sufficient safeguards could be implemented to assure that no contamination would occur.

Water harvesting technology is available to develop and utilize land in a variety of ways, ranging from agricultural farms to urban industrialized areas.

## REFERENCES

- Anonymous. 1975. Strong growth in planters. *Modern Plastics* 52(11):40.
- Anonymous. 1976. Agpipe picks up. *Modern Plastics* 52(3):54-55.
- Anonymous. 1976. NFT culture - the break-through of the century. *Grower Supplement*. February 14, 1976, pp. 33-40.
- Bucks, D.A., O.F. French, W.D. Pew and F.S. Nakayama. 1980. Multiple cropping with subsurface trickle irrigation. (In Progress).
- Bucks, D.A. and F.S. Nakayama. 1980. Injection of fertilizer and other chemicals for drip irrigation. *Agricultural Turf Irrigation Conference, Houston, Texas, Proceedings*. (In Press).
- Bucks, D.A. et al. 1980. Keys to successful trickle irrigation: Management and maintenance. *Fifteenth National Agricultural Plastics Conference, Tucson, Arizona, Proceedings*. pp. 3-8.
- Burns, E.R. et al. 1976. Using power plant discharge water in controlled-environment agriculture. *Tennessee Valley Authority Progress Report 2*.
- Busman, J.D. and D.D. Fangmeier. 1979. A digital controller for trickle irrigation. *Agricultural Engineering* 60(7):30-31.
- Cluff, C.B. 1967. Rafts: New way to control evaporation. *Crops and Soils Magazine, Madison, Wisconsin*.
- . 1968. A new method of installing plastic membranes. *Second Seepage Symposium, Phoenix, Arizona, ARS 41-147, Proceedings*. *Agricultural Research Service, USDA*.
- . 1971. Plastic catchments for economical harvesting of rainfall. *Tenth National Agricultural Plastics Conference, Chicago, Illinois, Proceedings*. pp. 193-202.

- . 1977. The compartmented reservoir: A method of efficient water storage in flat terrain. Conference on Alternative Strategies for Desert Development and Management, Sacramento, California.
- Cluff, C.B., M.M. Karpiscak, K.J. DeCook and F. Matter. 1981. Alternative Use Plan for City of Tucson Land and Avra Valley, Arizona. Office of Arid Lands Studies, Water Resources Research Center and College of Architecture, University of Arizona, Tucson.
- Courter, J.W. 1976. Survey of plastics in agriculture — current state of the art. Members of National Agricultural Plastics Association, November 1976.
- Courter, J.W. and P.H. Massey, Jr. 1977. Use of polymers in agriculture - USA. Seventh International Agricultural Plastics Congress, San Diego, California, Proceedings. pp. 523-532.
- Davis, S. and S.D. Nelson. 1970. Subsurface irrigation easily automated. Journal of the Irrigation and Drainage Division, Proceedings, ASCE(IR1):47-51.
- Dutt, G.R. and T.W. McCreary. 1974. Multipurpose salt-treated water harvesting systems. Water Harvesting Symposium, Phoenix, Arizona, Proceedings. pp. 310-311.
- Fangmeier, D.D. 1977. Alternative irrigation systems. University of Arizona, Department of Soils, Water and Engineering 77-4. 4 p.
- Ford, H.A. and D.P.H. Tucker. 1974. Clogging of drip systems from metabolic products of iron and sulfur bacteria. Second International Drip Irrigation Congress, Proceedings, San Diego, CA. pp. 212-214.
- Gustafson, C.D. 1976. Drip irrigation — worldwide 1975 situation and outlook. 1976 Annual Technical Conference Sprinkler Irrigation Association, Kansas City, Proceedings, 1976:58-65. Sprinkler Irrigation Association, 13975 Conn. Ave., Silver Spring, Maryland 20906.
- Gustafson, C.D. et al. 1974. Second International Drip Irrigation Congress, San Diego, California, July 7-14, Proceedings. 569 p.

- Hall, B.J. 1976. Drip irrigation - its problems and potential. *American Vegetable Grower* 24(4):24,56.
- Hartman, H. 1977. *Fiberglass Reinforced Panel Council, Society Plastics Industry, New York.*
- Hodges, C.N. and C.O. Hodge. 1971. An integrated system for providing power, water and food for desert coasts. *HortScience* 6(1):10-13.
- Hopen, H.J. and N.F. Oebker. 1976. Vegetable crop responses to synthetic mulches. *Technical Bulletin 1, NAPA, Simpson, Illinois 62985. 48 p.*
- Jensen, M.E., ed. 1973. *Consumptive use of water and irrigation water requirements. Technical Committee on Irrigation and Water Regulations, ASCE, New York, NY. 215 p.*
- Jensen, M.H. 1977a. *Controlled environment agriculture. Conference on Alternative Strategies for Desert Development and Management, Sacramento, California, Proceedings.*
- . 1977b. *Energy alternatives and conservation for greenhouses. HortScience 12(1):14-29.*
- Jensen, M.H. and H. M. Eisa. 1972. *Controlled-environment vegetable production: Results of trials at Puerto Penasco, Mexico, 1968-1970. Environmental Research Laboratory, University of Arizona, Tucson.*
- Jensen, M.H. and M.A. Teran R. 1971. *Use of controlled environment vegetable production in desert regions of the world. HortScience 6(1):13-16.*
- Kolbezen, M.J. 1977. *Permeability of plastic films to fumigants. Seventh International Agricultural Plastics Conference, San Diego, California, Proceedings. pp. 476-481.*
- McElhoe, B.A. and H.W. Hilton. 1974. *Chemical treatment of drip irrigation water. Second International Drip Irrigation Congress, Proceedings, San Diego, California. pp. 215-220.*

- Milke, E.A. and G.R. Dutt. 1980. Fruit production using water harvesting techniques on arid soils. Fifteenth National Agricultural Plastics Conference, Tucson, Arizona, Proceedings. pp. 82-85.
- Munnecke, D.E. 1977. Types and thickness of plastic films in relation to methyl bromide fumigation. Seventh International Agricultural Plastics Conference, San Diego, California, Proceedings. pp. 482-487.
- National Agricultural Plastics Conference, 1969, 1971, 1973, 1975, Proceedings. Simpson, Illinois 62935.
- Obeker, N.F., R.W. Peebles and C.B. Cluff. 1971. A mulch-water harvest technique for growing vegetables in arid lands. Tenth National Agricultural Plastics Conference, Chicago, Illinois, Proceedings. pp. 63-68.
- Phene, C.J., G.J. Hoffman and R.S. Austin. 1973. Controlling automated irrigation with soil matric potential sensors. Transactions, American Society of Agricultural Engineers 16(4):773-776.
- Rawlins, S.L., G.J. Hoffman, and S.D. Merrill. 1974. Traveling trickle systems. Second International Drip Irrigation Congress, Proceedings, San Diego, California. pp. 184-187.
- Roberts, W.J. 1975. Energy saving greenhouse. Rutgers University Cooperative Extension Service Publication, The State University of New Jersey, New Brunswick, New Jersey.
- Roberts, W.J., J.C. Simpkins and P.W. Kendall. 1976. Using solar energy to heat polyethylene film greenhouses. Transactions, ASAE 76-4011.
- Rolston, D.E. et al. 1979. Applying nutrients and other chemicals to trickle-irrigated crops. University of California Cooperative Extension Bulletin 1893, Berkeley, California. 14 p.

- Schales, F.D. 1973. Principles, practices, and problems involved in using plastic mulches for vegetable production. Eleventh National Agricultural Plastics Conference, San Antonio, Texas, Proceedings. pp. 145-148.
- Shearer, M.N. 1977. Minimum screening and automatic flushing. Fourth Annual International Drip Irrigation Association Meeting, Fresno, California, October, 1976, Proceedings. pp. 32-36.
- Smith, D.F. 1968. Mulching system and techniques. Eighth National Agricultural Plastics Conference, San Diego, California, Proceedings. pp. 112-118.
- Solomon, K. 1977. Minimum screening and automatic flushing. Fourth Annual International Drip Irrigation Association Meeting, Fresno, California, Proceedings. pp. 32-36.
- Titus, J.B. 1973. Environmentally degradable plastics: a review. Plastic Note N24, Plastics Technical Evaluation Center, Picatinny Arsenal, Dover, New Jersey 07301.
- Wendt, C.W. et al. 1973. Automation of drip irrigation systems. American Society of Agricultural Engineers Paper No. 73-25-2, St. Joseph, Maryland 49085.
- Wilke, O.C. 1974. Mobile drip irrigation systems. Second International Drip Irrigation Congress, San Diego, California, Proceedings. pp. 188-192.
- Wilson, D.L. 1972. Filtration, filters, and water treatment. Third Drip Irrigation Seminar, San Diego, California, Proceedings. pp. 17-23.
- Wood, A.S. 1975a. What's new down on the farm? A bumper crop in molded parts. Modern Plastics 52(8):38-41.
- . 1975b. What's new down on the farm? Lots of big film developments. Modern Plastics 52(11):37-39.

ANNEX VI

CALCULATION OF THE DEMAND FOR FILMS

TO BUILD GREENHOUSES

The Egyptian Government has a project for building greenhouses on 3,000 feddans (1,200 hectares) in a period of 8 years, in order to substitute imported ones.

The greenhouses' dimensions are 9 x 30 metres and 7 x 30 metres, and multiples.

For calculation purposes, the use of long-life films (of polyethylene and copolymers) has been considered. These films have a thickness of 150 to 200 microns and an approximate duration of two years. It is estimated that installations on 150 hectares will be carried out during the first year, this being increased by 150 hectares per year, from the second until the eighth year.

Without taking into account the design of the greenhouses to be built, it is estimated that the total consumption of films will be of approximately 6,000 tons: 300 tons for the first and second years; 600 tons for the third and fourth years; 900 tons for the fifth and sixth years and 1,200 tons for the seventh and eighth years, considering replacement requirements.

Taking into account that the average production of plants that manufacture wide films with the indicated thicknesses is of approximately 300 tons/month/machine, the total production time needed to obtain 6,000 tons of films, with one equipment, is of 20 months: 1 month during the first and second years; 2 months during the third and fourth years; 3 months during the fifth and sixth years and 4 months during the seventh and eighth years.

It is worth mentioning that, up to now, the Egyptian plastics industry can manufacture films with a maximum width of 8 metres. Therefore, the possibility of adapting these materials to the design of the greenhouses should be studied, until wider films are produced, in order to use those manufactured in the country.



ANNEX VII

PROPOSAL FOR A

SYMPOSIUM OF PLASTICS IN WATER MANAGEMENT

1. PLACE

PLASTICS DEVELOPMENT CENTRE, Victoria, Alexandria.  
(Opening Session: High Studies and Research Centre).

2. DATE

To be determined by Government.

3. OBJECTIVE

To promote up-to-date rural water management by means of modern technology using plastics, considering the role of the local plastics industry, as well as of the Plastics Development Centre in order to meet future requirements of the agricultural sector.

4. BACKGROUND

The Symposium is included within the activities of the project "Plastics for Agricultural Purposes", executed by the Plastics Development Centre (PDC) and the United Nations Industrial Development Organization (UNIDO).

The Symposium will also take into account the conclusions and follow the recommendations of the First Symposium of Plastics in Agriculture (Alexandria, 1981), concerning the use of plastics in water management to increase the areas of cultivated land as well as to apply it to the newly-gained land.

5. SUBJECTS

The main subject to be considered during the Symposium is the use of plastic products, such as pipes, films, fittings, drippers, sprinklers, tanks, drinkers, sanitary accessories, auxiliary inputs, etc., in:

- . Water catchment, storage and conduction.
- . Irrigation systems for crops in open areas and under plastics protection.
- . Hydroponic system.
- . Drainage.
- . Water management for domestic consumption.
- . Water management for livestock and agro-industries.

In this respect, the following aspects will be considered:

- . Types and properties of the plastic products used.
- . Selection, project design and evaluation of the system using plastics for water management.
- . Construction, installation, operation and maintenance of the referred systems.
- . Quality control and standardization.
- . Training requirements.
- . Technical, economic and social aspects.
- . Statistics of plastics used in other countries and areas involved.
- . Technology development and transfer.

6. PROGRAMME

There will be four days for lectures and discussion sessions, and one day for field visits.

The morning sessions will take place from 9 a.m. to 1 p.m. (for lectures) and the afternoon sessions from 4 p.m. to 6 p.m. (for discussions).

The time limit assigned to each lecturer will be 20 minutes.

The Organizing Committee will also arrange a workshop to discuss the technical, economic and social aspects of plastics applications in rural water management.

#### 7. PARTICIPANTS

Lecturers and observers from private and public sectors of the local industry and from the agricultural sector, UNIDO consultants and specialists from other countries, leaders in the use of plastics for water management.

#### 8. PAPERS

Participants interested in giving lectures must send the title and an abstract of the proposed paper, typed and double-spaced on one sheet of paper, accompanied by their curriculum vitae, before (two months before the initiation of the Symposium).

#### 9. WORKING LANGUAGES

Arabic and English with simultaneous translation.

#### 10. FIELD TRIPS

Visits are being programmed to industries, agricultural areas and the PDC experimental station.

11. INDUSTRIAL EXHIBITION

The companies and organizations interested in participating in the exhibition are requested to contact the Organizing Committee three months before the opening of the Symposium for further details.

12. PRIVATE MEETING ROOMS

Rooms will be available during the Symposium for discussions concerning business opportunities and technology development and transfer.

13. HOTELS

The Organizing Committee has surveyed hotels of different categories whose rates including taxes are:

<u>Hotel</u>	<u>Single</u>	<u>Double</u>
	L.E.	L.E.

14. REGISTRATION FEE

To be determined by the Government.

The payment of the fee will give participants the following rights:

- Attendance and participation in the sessions and field visits.
- Simultaneous translation.
- Working materials, programmes, lists of participants, technical and tourist documentation.
- Coffee during breaks.
- Luncheon.
- Local transportation.

15. ADDRESS OF ORGANIZING COMMITTEE

Plastics Development Centre, Alexandria, Egypt.

Activities to organize the symposium

(To start seven months before the opening date)

- Constitute the Organizing Committee .
- Prepare Symposium budget.
- Prepare and send invitation leaflets in Egypt and abroad.
- Promotional and publicity activities.
- Prepare lay out and conditions to participate in the Industrial Exhibition, and send to industries.
- Selection of papers to be included in the Symposium programme. and contact with authors, and request abstracts.
- Prepare Job Description to initiate recruitment of UNIDO consultants for the Symposium.
- Prepare first programme draft.
- Design, construction and installations of the stands for the Exhibition.
- Request an collection of products and materials to be exhibited.
- Prepare projection of slides and films facilities as well of simultaneous translation Arabic-English-Arabic.
- Prepare and print the final programme containing technical activities, field visits, opening and closing sessions and social events.
- .Nominate President and Secretary of each session.
- Prepare documentation to be delivered to the participants including the paper abstracts.



---

**4.04.04**