



TOGETHER
for a sustainable future

OCCASION

This publication has been made available to the public on the occasion of the 50th anniversary of the United Nations Industrial Development Organisation.



TOGETHER
for a sustainable future

DISCLAIMER

This document has been produced without formal United Nations editing. The designations employed and the presentation of the material in this document do not imply the expression of any opinion whatsoever on the part of the Secretariat of the United Nations Industrial Development Organization (UNIDO) concerning the legal status of any country, territory, city or area or of its authorities, or concerning the delimitation of its frontiers or boundaries, or its economic system or degree of development. Designations such as “developed”, “industrialized” and “developing” are intended for statistical convenience and do not necessarily express a judgment about the stage reached by a particular country or area in the development process. Mention of firm names or commercial products does not constitute an endorsement by UNIDO.

FAIR USE POLICY

Any part of this publication may be quoted and referenced for educational and research purposes without additional permission from UNIDO. However, those who make use of quoting and referencing this publication are requested to follow the Fair Use Policy of giving due credit to UNIDO.

CONTACT

Please contact publications@unido.org for further information concerning UNIDO publications.

For more information about UNIDO, please visit us at www.unido.org



19275

Distr.
LIMITED

ID/WG.520/6 (SPEC.)
9 October 1991

United Nations Industrial Development Organization

Original: ENGLISH

Tenth Session of the Leather and
Leather Products Industry Panel

Madras, India, 4-8 November 1991

TYPICAL TANNERY EFFLUENT AND RESIDUAL SLUDGE TREATMENT*

Prepared by

G. Clonfero
UNIDO Consultant

* The designations employed and the presentation of the material in this document do not imply the expression of any opinion whatsoever on the part of the Secretariat of the United Nations concerning the legal status of any country, territory, city or area or of its authorities, or concerning the delimitation of its frontiers or boundaries. The views expressed in this document are those of the author and do not necessarily reflect the views of the Secretariat of UNIDO. This document has not been edited.

TABLE OF CONTENTS

	<u>Page</u>
Introductory Note	3
I. General Principles	4
II. Preventive Interventions Inside the Factory	6
III. End of Pipe Treatment.	10
IV. Some Practical Examples of Design of Tannery Effluent Treatment Plant	14
A. Small-scale tannery	14
B. Medium size tannery	17
C. Cluster of tanneries	23
V. Sludge Production, Treatment and Disposal	28
Bibliography	32

INTRODUCTORY NOTE

The paper does not want to be a further theoretical study about the topic (many books and technical articles are available and an interested reader can find in annex a list of literature references) but a quick survey of the most relevant practical aspects in facing the tannery effluent problem and of the possible treatment alternatives, their expected efficiency and reliability. In order to give amore concrete (and I hope useful) contribute, three typical "clinical cases" taken as examples are studied here:

- i) individual effluent treatment plant for a small-scale tannery:
- ii) individual effluent treatment plant for a medium-scale tannery:
- iii) joint treatment plant for a cluster of tanneries of different sizes.

Besides this, other peculiar aspects (pre-treatment, recycles, etc.) or problems (sludge disposal, bad odour, etc.) are taken into consideration. In the proposed treatment philosophy, I have tried to remain within realistic (and compulsory) criteria for a developing country:

- low installation cost;
- few and simple civil works in concrete;
- un-sophisticated and low-maintenance equipment;
- little consumption of chemicals.

Of course, not all these conditions can always be satisfied, especially when, as often occurs, the same developing country requires very strict and unrealistic limits to discharge.

1. GENERAL PRINCIPLES

Disregarding the size of the factory, some basic data must be investigated and checked before starting any design or project of tannery effluent treatment plant. The most important information is indicated in Table I:

Table I

Tannery production:	raw material, production process (with particular attention to the unhairing and tanning cycles) and final product. quantity of the processed material (kg or number of hides or skins processed per day) eventual internal recycles water consumption
Tannery location:	area available for the effluent treatment plant and its location (rural or residential zone).
Limits to discharge:	imposed standards or (in absence) type of recipient and its characteristics (surface waters or sewer)

The biggest obstacles to a proper collection of data (and the most common errors) in a plant design are:

- i) The tanner, generally does not know his real water consumption (before its treatment the water is considered a free chemical and, furthermore, he tries to calculate its volume from the theoretical hide or skin and float rates or any individual process cycle, disregarding or underestimating the washings (very often in continuous) and the ancillary (cleaning of floor, equipment, etc.) or cooling waters. These quantities, especially for small scale factories, may represent an important part of the total water consumption.
- ii) Often (this happens more frequently in case of joint treatment plants) the tanners are reluctant to indicate to others their water consumption and leather production, and so give figures under the reality, or to limit their initial cost of linking to the joint plant, do not give a precautionary figure that takes into account also eventual short-term increases of the production.

For these reasons, a comparison between the declared volume of effluent and weight of the processed material must be always done. When the rate is too far from the usual values (see Table II), a careful re-check of the in-pup data is mandatory.

Table II

Raw material	Water Consumption Litres per kg of raw material (soaked or wet salted weight)
hides (chrome tannage)	30 : 50
hides (vegetable tannage)	20 : 40
skins (mix tannage)	30 : 60
skins (furrery)	50 : 100

- iii) The initial limits to discharge may be subject to change in future, both in magnitude and in the type of parameter under control.

So the plant must be designed more flexible, or as expandible as possible in order to prevent or to be adapted to the new stricter impositions. It is not always easy to represent this condition, but as a principle, a planner must foresee a residual area for further plant increase, and the possibility to improve the plant's efficiency (by means of chemicals dosage or other).

- iv) Some planners start a project of effluent treatment plant without considering at the same time the problem of the final disposal of the residual sludge.

Unfortunately, this industrial sector is characterized by effluents with a high suspended solids content (both organic and inorganic) and the current "end of pipe" treatment methodologies are, in the final analysis, nothing more than a relocation of pollution from a liquid form to a solid, or semi-solid one (the sludge).

- v) Initially, the interest of the people involved is entirely focused on solving the effluent problem (i.e. to comply with the imposed standards for discharge) forgetting the other (together with sludge) paramount aspects correlated with the waste-water treatment: the air pollution for bad of odour production.

This is comprehensible, in fact a tannery in which there is no effluent treatment plant does not smell too much, and if it does, it depends on limited sources and times. When effluent treatment plant is installed, the risk of bad dour is enormously increased, and it may cover an area of several kilometers. For this reason, it is of paramount importance for the same future factory survival, that the approach to the effluent treatment plant's project be carefully studied also from this point of view.

II. PREVENTIVE INTERVENTIONS INSIDE THE FACTORY

The most common recommended interventions are the reduction in water consumption, or its partial reuse, and a better utilization of chemicals (high exhaustion or recycle techniques), or the utilization of the "environment friendly" process.

A. Reduction in water consumption or its partial reuse

A reduction in consumption can be advisable when the factory is using an evident excess of water. This fact will represent an obvious saving in the effluent treatment plant cost due to the smaller effluent volume, and a parsimony of this common good, which is the most important thing.

On the other hand, reducing drastically the amount of water, besides the risk of poor quality of the leather, can cause the following problem: the pollution level of the concentrated effluent, hardly can be turned to the usual standards for discharge and, furthermore its salinity, sometimes, makes the water non reusable for irrigation.

B. Better utilization of chemicals (high exhaustion or recycle techniques) or utilization of "environment friendly" process.

A more rational use of the chemicals is always recommendable, but, in general, due to economical difficulties of leather industry all over the world, this is autonomously done by the same industrialist.

1. Environment friendly products

The use of high exhaustion chrome or alternative metallic salts in tanning, ammonia free products in de-liming or sulphide substitutes in unhairing are excellent alternatives but quality and cost aspects are involved, that are inside the one competence of the tannery management.

At the moment, some problems (quality, cost, reliability, etc.) and, perhaps, preconceptions are precluding their utilization on a large scale. However, in the future, under the pressure of both the increasing importance of the environmental aspects, and the technical and commercial efforts of the producing companies (pollution is a big business) the "environment friendly" technologies will become in my opinion, more and more competitive with the classical ones.

2. Internal recycles.

The chrome spent tanning and the used liming wastes are, in my judgement, recycles deserving to be mentioned (the pickle recycle is only a theoretical possibility).

Recycle of chrome

The spent chrome reuse can be a useful alternative to that of the high exhaustion in medium or large scale tanneries in which the recovered product gives a profit that justifies the operational and installation costs.

For small factories the best solution is the separate pre-treatment (precipitation of chrome hydroxide with lime) in order to produce a small volume of chrome sludge (considered more toxic) and to facilitate the final disposal of the other sludge (quantitatively more significant).

Two aspects must be clarified regarding this topic:

- i. the chrome pre-treatment or recycle gives no advantage in the general effluent treatment plant but it can alleviate the potential problems and costs of the disposal of the residual sludge. Furthermore, in many countries, this is imposed by the environmental regulations.
- ii. the belief that chrome III gives a useful contribution in the flocculation of the mixed effluent is, in principle, right but in practice, is to be demonstrated, and in any case, this benefit will never pay for the difficulties (sometimes excessive) that environmental authorities of many countries create for the disposal of chrome containing sludge.

Recycle of the unhairing baths.

The reuse of lime-sulphide unhairing liquors is a technique quite used in many developing countries. Two are the processes generally adopted :

- recycle without solids removal
- recycle with solids removal (fine screening and/or sedimentation).

Few cases of systems using the ultrafiltration are known in Europe but the application of this process at a large scale has always encountered difficulties and, furthermore, in my opinion, it is too sophisticated and therefore adaptable only to big and high-technical-level industries.

The advantages of this recycle are doubtful:

- i. it does not represent necessarily a reduction in water use; in fact, the liming is often done in the second soaking bath that must be discharged if liming is recycled.
- ii. the organic substances that the hides or skins lose in a fresh liming, must be equally lost in the recycled one in order to prepare a proper pelt. After a few cycles, the pollution saved in the first recycles will be lost in the successive washings.
- iii. when sedimentation is adopted, big difficulties are encountered in the de-watering (especially if mechanical) of such colloidal sludge.

- iv. the one sure benefit for the effluent treatment plant is the reduction of the sulphide content in the mixed influent.
- v. problems have been encountered in obtaining the original quality level of the produced leather : some tanneries after a period of trials have abandoned the recycle.

3. Other in-plant control technologies.

Many different technologies are reported in literature about possible alternatives for limiting the tannery pollution, but to treat diffusively this topic would carry us far from our principal argument.

I want only to comment here two pre-treatments used on large scale in a leather cluster served by a big joint, municipal and industrial, effluent treatment plant in the north of Italy :

- brushing off adhering salt from the salted hides before soaking;
- removal of hair from unhairing baths.

The first operation can be manually done shaking vigorously (two persons are needed) the open salted hide on a plain surface (e.g. a 500 litres metal drum) or mechanically passing the hide through a rotary steel bar cylindrical drum; in both cases the adhering salt is taken off at dry on the floor.

The system allows a small reduction in the chloride content of the mixed effluent: the brushed off salt is about 2% of the weight. Assuming a water consumption of 35l kg of hide, a chloride reduction of 300 - 350 mg/l can be expected in the mixed effluent : this amount represents less than 10% of the total. Furthermore, the pre-treatment is ineffective in the case of brine-cured hides.

The second process is more interesting and is based on the preservation (complete or partial) of the hair followed by a mechanical separation. The most known processes of hair preservation are reported in Table III.

Table III

Hair-save liming processes

Process with complete preservation of the hair
a. Painting b. Enzymatic unhairing c. Pressure feed process (inoculation)
Process with partial reduction of the hair
a. Drum painting b. Darmstadt through feed process c. Reapid unhairing-coating process d. SIROLIME system e. Liming by immunization

The necessity of hair preservation is dictated by both mechanical and chemical reasons :

- the well preserved or slightly pulped hair can be better separated via fine screening;
- 50% ca. reduction in terms of C.O.D. of the hair-burn process can be obtained utilizing the hair-save one (see Figure 1)

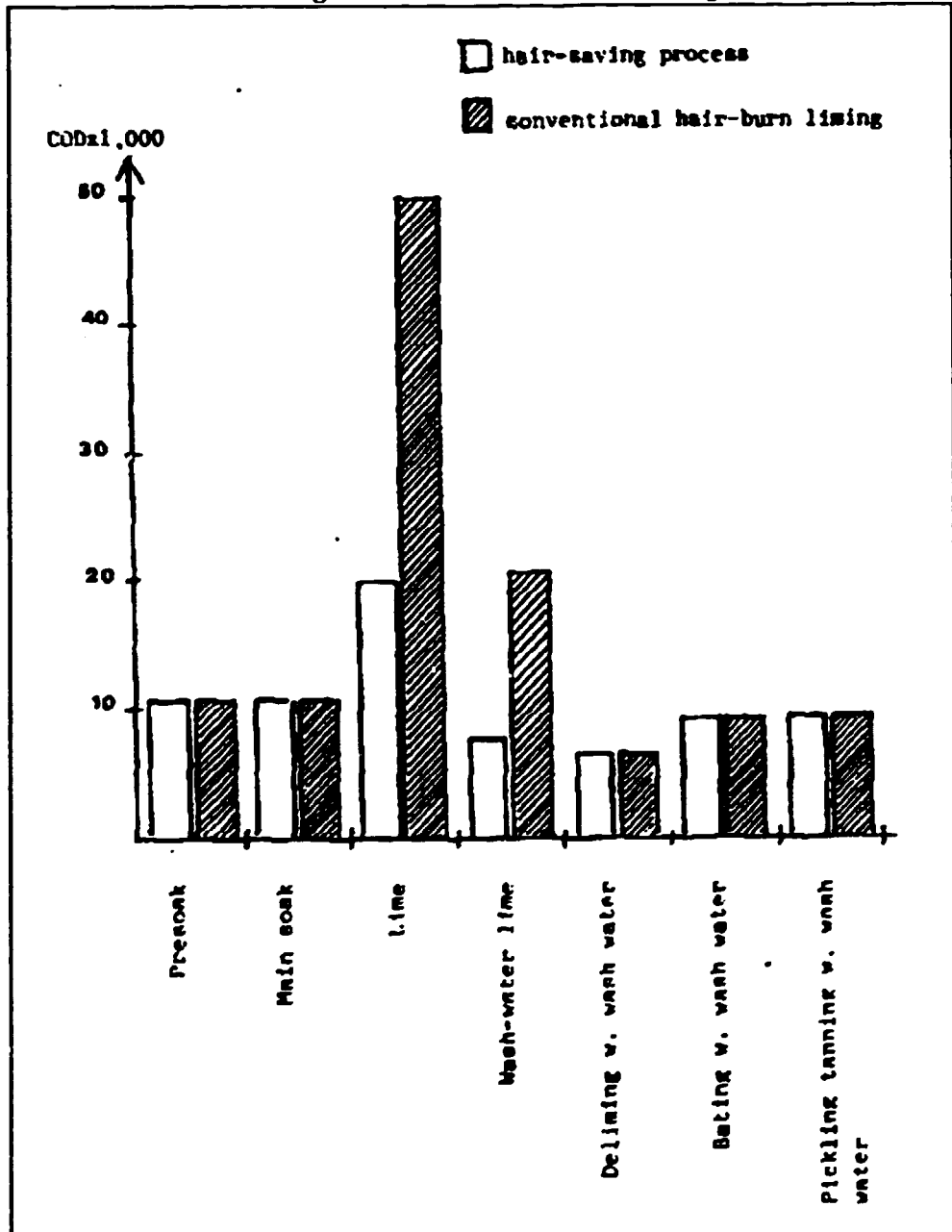

Figure 1

Comparison between hair-save and hair-burn liming process in terms of COD values (Courtesy of SCIB S.p.A.-Italy)

The principle of liming by immunisation is the one generally adopted by the tanners of the previously mentioned leather cluster in which the processed material is almost totally bovine hide. The soaked hides are pre-treated in the drum with calcium hydrate (pH = 12/13) in order to achieve the hair immunisation (under the influence of alkali, the cystine of hair transforms into lanthionine, which can no longer be hydrolysed by sulphide. The consequent addition of sodium sulphide causes a reduction only in the still not immunised hair-roots, which leads to hair loosening. The hair is separated by means of a fine screen. The recovered hair is sent to a local industry producing fertilizer. A comparison between hair-save and hair-burn liming process is reported in Table IV.

Table IV

Typical analytical effluent data from Rohm HS Process¹ and a conventional hair pulping system²

	COD ³ (mg O ₂ /l)	Sulfide ³ (mg/l)	Nitrogen (mg N/l)	Recovered hair (% dry hair to salted weight)	Settleable solids	Suspended solids
HS Process (hair recovery during recycling)	22,600	800-1,000	1,700	3.0	35	22
HS Process (hair recovery at the end of liming)	24,700	700-1,000	1,920	2.7	65	29
Pulping-hair system	39,800	1,800-2,200	2,670	0.5	705	61

¹ 1.0% ERHAVID HS, 0.9% Sodium sulphhydrate (72%), 3.0 % lime (total)

² 1.7% Sodium sulphhydrate (72%), 1.2% Sodium sulfide (60%), 3.5% lime (total)

³ measured in the supernatant of lime liquor (without washing liquor)

III. END OF PIPE TREATMENT

Characteristics of the raw effluents.

The tannery's effluent is characterised by the following main peculiarities:

- intermittent flow
- wide fluctuation in pH (from 2 to 12 ca) and big variations in the type and load of the carried pollutants (organic and inorganic)

The most common pollutants are :

- coarse material: hair, fleshings, shavings, plastics, etc.
- soluble inorganic : chlorides and sulphates
- suspended solids: inorganic (lime and grit) and organic (manure, proteins, grease, oil, hair, etc.)
- soluble organic: many not always identifiable organic products enter in a tannery waste stream as proteinaceous matter from hide skin or as unfixed chemicals. They are collectively represented by means of the following pollution parameters:

BOD (biochemical oxygen demand five days)

COD (chemical oxygen demand)

- sulphide
- ammonia
- trivalent chromium salts and/or other metallic salts
- toxic substances: some toxic pollutants can be also present as preservative and biocides (pentachlorophenol, chresols, etc.) heavy metals (organometallic dyes) and auxiliaries for finishing (aromatic solvents).

In Table V some data are indicated with respect to the pollution of tannery mixed effluents (source "Environmental Consideration in the Leather Producing Industry" Project UNIDO/ITD 337 - 9 June 1975).

Table V

Amounts of pollution per toon of raw material (salt weight).

		Chrome Tannage	Vegetable Tannage	Range
Alkalinity	eq/t		750	
Total Solids	kg/t		675	350-1250
Total Ash	kg/t		375	250-450
Suspended Solids	kg/t	150	75	70-200
Ash in susp. solids	kg/t	60	25	25-60
Settled Solids (2 h)	m ³ /t	6	3	1.5-7.5
BOD5	kg/t	60	85	40-100
IOD	kg/t		10	
KMnO ₄ -value	kg O ₂ /t	70	120	
COD(K ₂ Cr ₂ O ₇)	kg/t		175	120-280
Sulphide	kg/t		7	
Total Nitrogen	kg/t		10	
Ammonia Nitrogen	kg/t		3	
Chrome	kg/t	5	0	
Chloride	kg/t		160	
Sulphate	kg/t		40	
Phosphor	kg/t		0.07	

In Table VI the data are obtained from an Italian chrome tannery during a period of tests in which the floats of the various processes were collected separately and analysed.

Despite some difference in values, that may depend on the particular system or work, these data give a good idea of the pollution generated at different stages of leather production.

Furthermore, in Table VII the limits imposed by Italian regulations for discharge to municipal sewer or surface water are compared to the means values of the mixed effluence of a tannery.

From these values, one can have an idea of the difficulty of the problem, and the high efficiency required in a treatment plant.

Table VI
Characteristics of the individual streams of an Italian chrome tannery

Pressing cycle (referred to 800 kg of raw hides)	Water		COD mg/l	COD kg	COD ₂ on total	BOD ₅ mg/l	Suspended solids mg/l	Suspended solids Kg	S.S.I on total	Chrome mg/l	Sulphide as S mg/l	pH
	Water m ³	on total consumpti										
Salt Washing	10.00	7.51	8.800	167.2	6.220	4.200	3.340	63.460	4.88			6.9
First Washing	5.00	1.97	2.000	10.0	0.370		730	3.650	0.28			7.2
Second Washing	5.00	1.97	1.850	9.2	0.340		970	4.850	0.37			7.1
Soaking	19.00	7.51	17.240	327.5	12.200	7.500	5.420	102.980	7.93		138	12.6
Liming	19.00	7.51	60.400	1147.6	42.750	24.500	42.900	815.100	62.70		3.200	12.6
Washing	32.00	12.66	8.200	262.4	9.770		3.580	114.560	8.80		420	11.9
Fleshing	2.00	0.97	2.000	4.0	0.140							8.4
Total beamhouse	101.00	39.92	19.089	1928.0	71.820		10.936	1104.600	85.00		761 (av.)	
First Washing	12.00	4.74	7.000	34.0	3.120		1.920	23.040	1.80		300	11.5
Second Washing	50.00	19.78	1.250	62.5	2.320		770	38.500	2.96		8	10.5
Deliming & Bating	10.00	3.95	19.700	197.0	7.330	14.300	3.790	37.900	2.90			7.0
Washing	34.40	13.61	6.900	237.3	8.840		1.070	36.800	2.83			7.2
Pickling & Pretanning	10.00	3.95	5.350	52.5	1.990	1.450	1.590	15.900	1.22	1.380		2.6
Tanning	10.00	3.95	4.550	45.5	1.690	740	1.240	12.400	0.95	3.120		3.8
Pressing	1.00	0.39	5.500	5.5	0.200		1.200	1.200	0.09	1.850		3.9
Total tanning	127.40	50.37	5.379	685.3	25.830		1.300	165.740	12.90	367(av.)	31 (av)	
			average				(average)			46.85 Kg tot	4 Kg tot	
Retanning(Chrome)	4.15	1.64	4.700	19.5	0.720		870	3.610		380		4.0
Neutralization	4.02	1.59	2.520	10.1	0.370		1.500	6.030				6.0
Fatliquoring&Dyeing	5.75	2.27	6.220	35.8	1.330		2.700	15.520				3.4
Total grain side process	13.92	5.50	4.697	65.4	7.430		1.800	25.160	1.90	143 (av.)	1.99 Kg tot.	
							(average)		1.99 Kg tot.	1.99 Kg tot.		
Retanning (Chrome)	1.37	0.54	1.200	1.6	0.061		540	0.740		250		3.5
Washing	0.95	0.37	1.000	1.0	0.035		270	0.256		55		4.6
Neutralization	2.06	0.84	560	1.1	0.042		420	0.865				6.6
Washing	3.44	1.36	150	0.5	0.020		170	0.584				6.1
Retanning (Resin)	0.68	0.27	230	0.2	0.005		50	0.034				5.9
Fatliquoring	0.68	0.27	170	0.1	0.004		240	0.163				4.2
Dyeing	1.20	0.47	950	1.1	0.042		120	0.144				3.4
Total crust process	10.38	4.09	544	5.7	0.210		280	2.786	0.20	37 (av.)	0.39 Kg tot.	
			average				(average)					
GENERAL TOTAL	252.70	100.00	10.600	2684.4	100.000	5.160	5.100	1298.290	100.00	195 (av.)	319 (av.)	
			average			(mixed sample)	(average)			49.23 Kg	80.85 Kg	

Table VII

Comparison between Italian standards and mean pollution of an homogenized effluent of a chrome tannery

Parameter	Unit	Italian limits		Raw Effluent (range)
		sewer	surface	
pH		5.5-9.5	5.5-9.5	7.5-9.5
Settleable material	ml/l	0.5	2.0	50- 100
Suspended solids	mg/l	200.0	80.0	2,000-4,000
BOD5	mg/l	250.0	40.0	3,000-5,000
COD	mg/l	500.0	160.0	5,000-8,000
Oil & Grease	mg/l	40.0	20.0	200- 400
Sulphide	mg/l	2.0	1.0	150- 300
Ammonia Nitrogen	mg/l	30.0	15.0	100- 200
Chrome III	mg/l	4.0	2.0	100- 150
Phenols	mg/l	1.0	0.5	very variable

General considerations

In general, a primary treatment alone does not guarantee a final effluent conforming to the usual standards for discharge in surface waters.

Note: by the term "primary" those physico-chemical treatments are meant which precede the biological (secondary) treatment.

On the other hand, a totally biological treatment, although theoretically possible, is as a general rule to be avoided in tannery, due to its difficulty in the process control and operation, and, furthermore, the risk to entrust all the plant efficiency to a single treatment step. In general, it is preferable to have a two-phase plant (physico-chemical and biological) allowing adaptation of the primary to the secondary, or vice-versa.

The choice, therefore, is of technical nature, but costs are involved: on the one hand the primary treatment must guarantee an effluent suitable for the secondary one; on the other hand, the same secondary treatment may be designed for greater or lesser efficiency.

The following criteria are essential to the selection of the most appropriate treatment process:

- i. area available : whether it allows longer treatment systems or requires a more compact one.
- ii. plant location : rural or residential zone. Certain systems (i.e. lagooning, sludge drying beds, etc.) are not suitable in this second case (bad odour).
- iii. local climate : climate plays an important role in the choice of the treatment, especially as it affects the secondary treatment (temperature) and drying of sludge in drying-beds (rain).
- iv. recipient characteristics and local environmental regulations and standards.

IV. SOME PRACTICAL EXAMPLES OF DESIGN OF TANNERY EFFLUENT TREATMENT PLANTS

Foreword

The following examples are typical cases that can occur in the reality. The solutions here proposed must be considered technical alternatives more than general criteria of design.

In fact, in my opinion, it is more important to focus on the problems than to define standard solutions: there are many ways to reach the same goals.

EXAMPLE A : Individual effluent treatment plant for a small-scale tannery

Tannery data:

- raw material : dried goat skins, 0.5 kg. per piece
- production : 100% wet-blue
note: pull hair liming with lime and sodium sulphide, deliming with ammonium sulphate and chrome tanning
- quantity : 3,000 skins per day, i.e. 1,500 kg of dried weight;
max. production (no future increase foreseen)
- water consumption : 40 litres per skin
note: this quantity corresponds to 40 litres ca. per kg. of soaked weight (2 x dry weight)
- total waste water volume : 120 m³ per day
- miscellaneous data
 - i. no internal recycles
 - ii. rain water is collected separately
 - iii. six working days per week, 8 hours per day (one shift).
 - iv. final discharge into surface water (river).
 - v. requested standards:
 - pH : 6 - 8
 - Suspended solids : 200 mg/l
 - BOD : 100 mg/l
 - COD : 200 mg/l
 - Cr III : 1 mg/l
 - Sulphide : 1 mg/l
 - Oil & Grease : 20 mg/l
 - Phenols : 1 mg/l
 - vi. other regulations : the chrome III must be separately precipitated
 - vii. factory located in a rural zone far from residential area
 - viii. a large area is available for the effluent treatment plant
 - ix. the climate is that characteristic of a sub-tropical zone with a short heavy rain period.

First considerations:

- i. to comply with the standards indicated over requires a biological treatment
- ii. the factory size does not allow sophisticated equipment both for economical (installation and maintenance costs) and operational (lack of skilled personnel) motives
- iii. the labour cost is low; chemicals are mostly imported and expensive

Proposed effluent treatment plant

A possible treatment alternative is resumed in the following block-scheme.

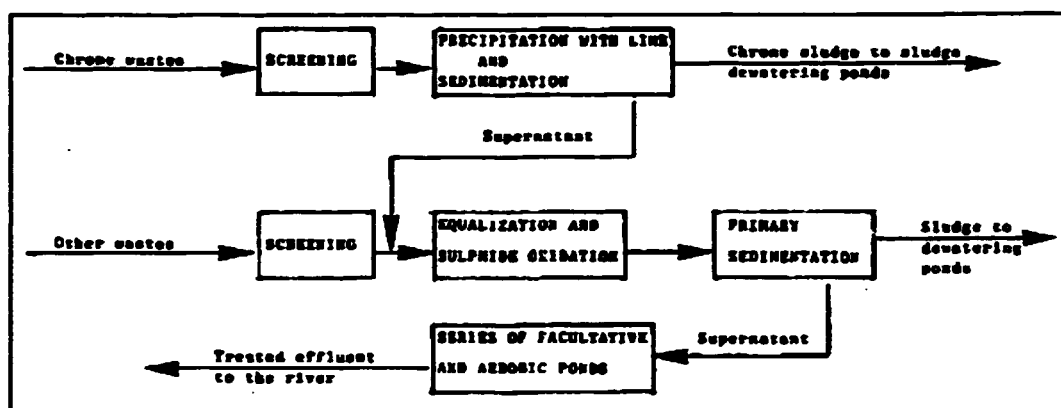

Figure 2

This solution offers the following advantages:

- the civil-works in concrete are limited
- the biological treatment can be easily increased in the future, installing further ponds
- the primary treatment operations can be restricted inside the day-time period; peak-loads are not affecting such an extended biological treatment
- the same primary treatment efficiency can be improved in the future introducing a flocculation with chemicals
- the installation of a primary treatment and a pre-treatment of the chrome liquors should reassure the local environmental authorities of the use of simple ground ponds for the biological and the sludge treatment. An eventual lining (clay and/or polythene sheeting) for impermeabilizing the bottom can be requested only for the chrome-sludge ponds

Disadvantages:

- flies, insects and bad smell; but they are not big problems in the hypothized case
- the installation costs will become prohibitive if the local environmental authority imposes sludge drying beds in concrete and/or fully impermeabilized ponds.
- problems can be encountered in complying with the requested limit for the suspended solids : a massive growth of algae is expected in the last ponds. Also the BOD and COD values can exceed the limits if algae contribution is

considered in the analysis. In some countries, these standards are checked without algae, i.e. after filtration or centrifugation of the sample.

Description of the effluent treatment plant

(see also the annexed flow-sheet)

- a. **Pre-treatment of chrome liquors:**
after screening (bar screen) the chrome containing streams are piped into a storage tank.
When the daily quantity has been discharged, the liquor is mixed by injection of suppressed air from the factory' network or other blower/compressor.
Lime milk is added up to pH 8 ca.; the final value can be controlled by means of a paper pH-indicator.
Stop the mixing, the liquor is allowed to settle for the necessary time : a minimum of 4 hours is necessary for a good separation of solids
The most of the supernatant is pumped utilizing a self-priming pump (helicoidal screw pump) to the general effluent treatment and, after, deeping the suction pipe, the chrome hydroxide sludge is transferred to the dewatering ponds.
This batch procedure does not require any mechanized or automatic control but only a certain attention of the operator.

- b. **General treatment:**
After screening (bar screen) the other effluents from the factory flow into the equalization and sulphide oxidation tank.
Note : a pumping station can be necessary if the ground characteristics or the land slope are unfavourable.
The volume of the tank must be dimensioned in order to assure a good homogeneization of the various streams and an equalizator. of the flow-peaks.
Its volume is directly depending from the process inside the factory : usually it is designed for 24 hours retention time (i.e. volume equal to the daily effluent volume) but it can be bigger if the factory does some process (e.g. unhairing) only some days of the week or smaller in case of large tanneries in which the same internal cycles realize a statistical homogeneization of the effluents.
The equalization tank must be mixed in order to avoid solids deposit : in this case, a mixing by suppressed air (blower and air-diffusers) has been selected.
In fact, this system is preferable in small effluent treatment plants, due to its simplicity. Particular care must be given in the air distribution and non-clog diffusers must be installed.
Furthermore, the air supply must never be stopped for long period (during week-ends or other)
The air supplied for mixing enables the sulphide oxidation too; in fact the quantity necessary for mixing, in general, overcomes that requested for the sulphide oxidation.
The homogenized liquor is pumped (submersible pump) at uniform flow to the primary sedimentation tank passing through a pit in which an eventual dosage of chemical (flocculation) can be done if necessary in the future.

The proposed clarifier is a vertical sedimentation tank, Dortmund type, with a pyramidal bottom 60° shaped. This slope is necessary to facilitate the sludge draw-off.

The primary sedimentation is dictated by the necessity of limiting the suspended solids (both inorganic and organic) sent to the lagoons that, otherwise, will be filled in short time. The supernatant flows by gravity to the biological treatment realized into a series of facultative/aerobic ponds.

The design of this part of the treatment is not easy: in fact its efficiency is not only depending from the retention time but also from the local climatic conditions and the characteristics of the influent.

To try a theoretical design of a facultative pond, like is usual for other more compact biological treatments, is, in my opinion, impossible: this treatment must be based on the practical experience in similar plants, then tested, and, if necessary, adjusted.

In this example, assuming an average depth of the water level in the ponds of 1.5 metres and a total retention time of 30-40 days, a total of 2,400 - 3,200 m² will be indicatively necessary.

The chrome sludge and the primary sludge are sent to separate sludge-ponds for dewatering.

The dewatering is mostly caused by evaporation, for this reason, the maximum height of the liquid sludge in the pond must never exceed 50 cm. Like for the biological treatment, also the sludge dewatering by evaporation is very difficult to design.

The sludge production can be realistically estimated in 0.10 kg of dry solid per 1 kg of processed skin (soaked weight); i.e. 300 kg of dry matter or 7.5 m³ of liquid sludge at 4% solids content. Adopting a sludge level of 30 cm and hypothesizing a mean drying period of 20 days, a 500 m² surface results.

To reduce the cleaning up time and limit the quantity of dewatered sludge to be transported at the same time to the final disposal, a n 4 ponds of 10 x 20 m (total surface 800 m²) are suggested.

EXAMPLE B: Individual effluent treatment plant for a medium size tannery

Tannery data:

- raw material : wet-salted haired hides, 25-30 kg/hide
- production : finished upper leather
- Note: pull hair unhairing with lime and sodium sulphide, deliming with ammonium sulphate, chrome tanning and vegetable tanning.
- quantity : 15,000 kg wet-salted weight per day
- water consumption : 35 litres per kg of salted material
- total waste-water volume : 525 m³ per day
- miscellaneous data
 - i. the recovery of the chrome from spent tanning baths is requested; Total daily volume : 15 m³ with an average content of 6 g/l of Cr O i.e. 90 kg of Cr O recoverable per day
 - ii. rain water is collected separately
 - iii. five working days per week, two day shifts and night supervision
 - iv. discharge into municipal sewer

v. requested standards:

- pH : 6 - 9
- coarse material : absent
- Cr III : 4 mg/l
- Sulphide : 5 mg/l
- BOD : 800 mg/l
- COD : 1,200 mg/l
- suspended solids : 400 mg/l
- oil and grease : 100 mg/l

(no standards for ammonia nitrogen and salts - chloride and sulphate)

vi. the factory is located in an industrial zone, 2 km from a residential area

vii. a 100 x 50 m area is the maximum available for the effluent treatment plant

viii. the climate is continental (hot summer and cold winter)

First considerations.

- i. a good primary treatment can guarantee a final effluent inside the requested standards.
- ii. the factory size can justify a more mechanized effluent treatment plant
- iii. the labour cost is low and some basic chemicals are locally produced
- iv. due to the tannery location, future problems for bad odour must be taken into account
- v. the small area available does not allow the utilization of extended treatment for effluent or sludge

Proposed effluent treatment plant

A possible treatment alternative is resumed in the following block-schemes:

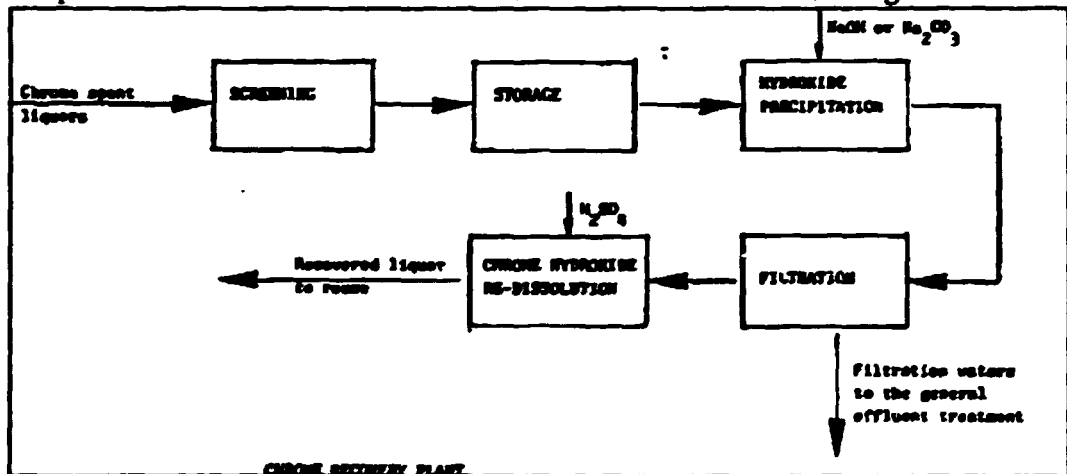

Figure 3

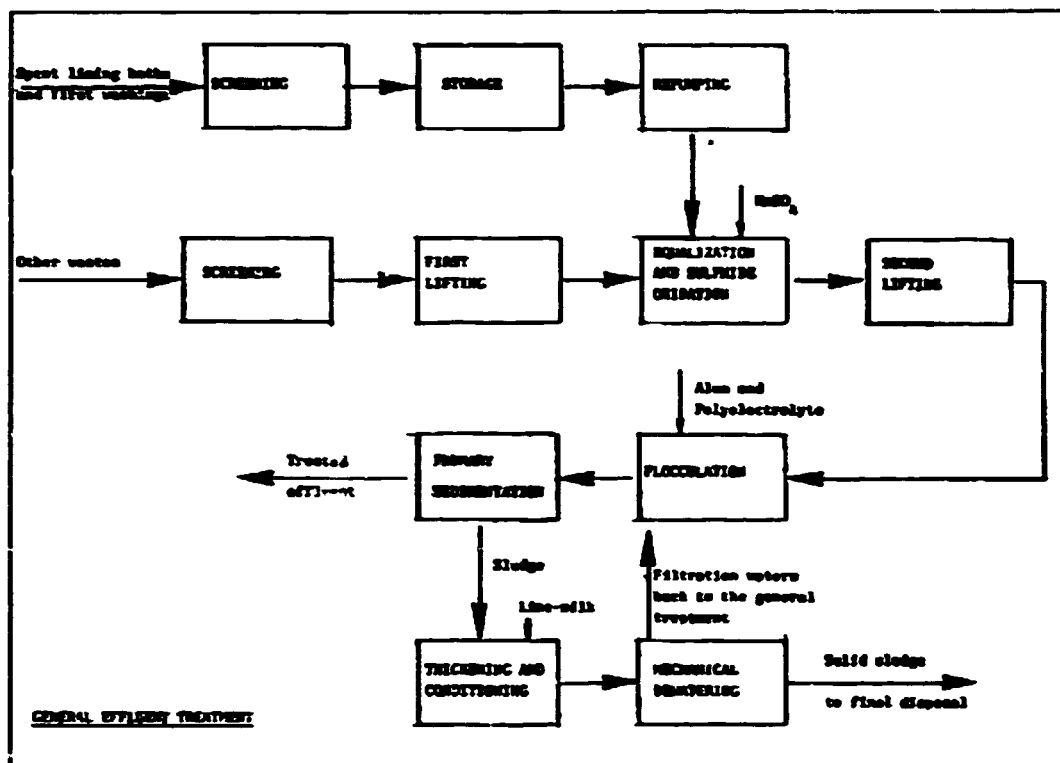

Figure 4

Chrome recovery

The proposed plant for chrome recovery is a classical design that foresees the chrome precipitation with alkali, hydroxide filtration by filter press and successive re-dissolution with sulphuric acid.

The advantage of this method is a more uniform, concentrated and high quality recovered liquor. Furthermore, the clear filtered water (pH 7.5 ca., a mean content of Cr III of 10-20 mg/l and 6-7 Be density) can be utilized in the preparation of the pickle bath.

The installation cost is high but the recovered product allows a profit. The recovered chrome (20% of that used in tanning) must be reused in the same percentage, together with the fresh product.

Starting up of the plant apart, no analytical controls are in general necessary, especially if the tanning is done in the same pickle bath (the residual acidity keeps the recovered chrome from precipitating, due to an eventual excessive basicity.)

General effluent treatment

The proposed primary effluent treatment plant is a classical treatment and catalytic oxidation of sulphide followed by chemical flocculation and primary sedimentation) with the peculiarity of the separation and re-pumping of the spent liming liquors to the general treatment during the day.

The advantages of this last solution are:

- a more uniform distribution of these highly polluted streams generally discharged from the factory in the morning during a short lap of time. That enables a better design of the sulphide oxidation process and a uniform dosage of the catalyst.
- the possibility to instal a smaller equalization tank: in fact, due to their strength, these streams will confer their character to the mixed effluent when regularly dosed. Furthermore, their alkalinity will assure a pH within neutral-alkaline values, limiting the risk of bad smell production.

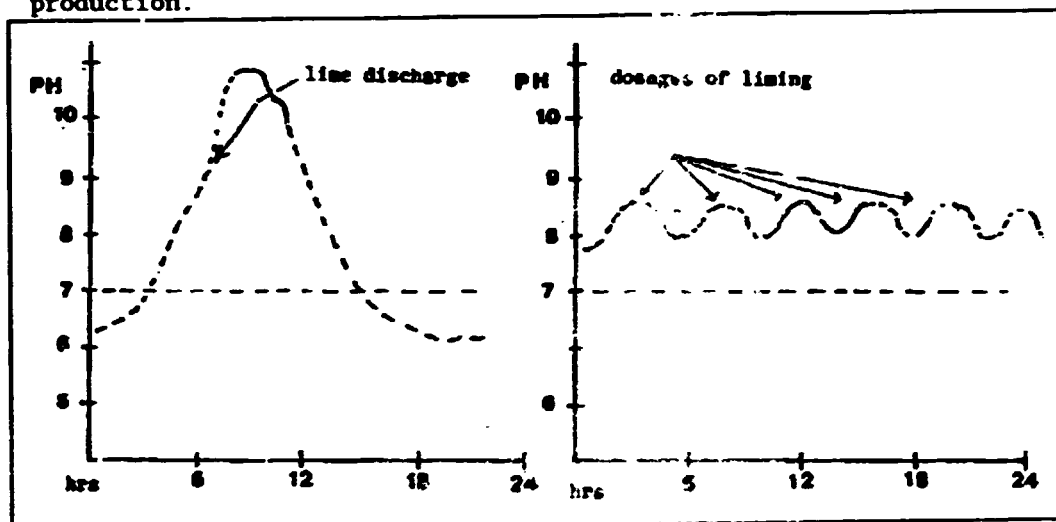

Figure 5

The primary sludge must be mechanically dewatered, in fact, the installation of drying beds is unrealistic in this case.

Assuming a sludge production of 0.15 kg of dry material per 1 kg of wet-salted hide, we obtain 2,250 kg of dry solids or 55-60 m³ per day of liquid sludge at 3-4% of dry matter. Furthermore, to instal a storage tank between the sludge production (primary sedimentation) and the filtration station is advisable in order to render the two processes independent. This is mandatory with a plate-filter-press discontinuous machinery, while the primary sedimentation works continuously.

A thickening tank has been proposed here with the functions of both creating this storage tank and assuring a higher solid content in the liquid sludge sent to the filter. Furthermore a lime-milk dosage has been foreseen to limit the risk of bad smell and increase the sludge filterability.

Description of the effluent treatment plant
(see also the annexed flow sheets)

- a. Chrome recovery plant.
After screening (bar screen 5-10 mm openings) the chrome liquors are piped by gravity into a 20 m, underground tank in concrete. The tank bottom must

be sloped towards the pit where the submersible pump is installed in order to facilitate the periodical cleaning. The installation of such a tank, allows a complete independence between the recovery process and the operations inside the factory.

The stored liquor is pumped to a 10 m, precipitation tank, fitted with a mixing device, where the chrome hydroxide is precipitated with an alkali (soda ash or sodium hydroxide). At the end of the precipitation, the pH must be stable around the value 7.5-8.

The filter press is fed by means of a helicoidal pump, in fact the working pressure rarely exceeds 4 Bars. The final pressure value (the pressure increases with time and filling of the filter) must be checked during the starting phase of the plant.

To respect the final pressure and total time of the filtration is important in order to obtain a hydroxide cake at a constant Cr_2O_3 content. Usually, the cake has a 30% ca. of solid and 10% ca. of Cr_2O_3 content. Ultimately the filter is opened and the hydroxide cake discharged.

This cake is, manually or by means of a conveyor, transferred into the re-dissolution tank in acid-proof material (fibre glass reinforced resins). The amount of conc. sulphuric acid necessary for the dissolution and restoring a 33% basicity ca. must also be checked in the plant starting phase (in general 0.8 - 1.0 kg of H_2SO_4 conc. are necessary per 1 kg. of (recovered) Cr_2O_3).

A possible cheaper alternative can be the precipitation of the chrome by magnesium oxide. In this case the precipitation tank (preferably in acid proof material, fibre-glass reinforced resins, or in concrete with acid resistant lining, paint, ceramic or other) after hydroxide sedimentation and supernatant draw-off will be utilized as re-dissolution tank. If well operated, this method allows quite high concentration of Cr_2O_3 (4-5%) and acceptable consistency of the recovered liquor.

b. General effluent treatment.

The spent unhairing baths and the first washings are separately collected (by means of a by-pass or other) and after screening (bar screen, 7-10 mm openings, or, better, brushed screen, 2-3 mm diam. holes in order to take off the most of the unpulped hair) sent by gravity into the storage tank. The tank capacity equals the daily volume of liquors. A mechanical device (mixer or submersible mixer) will prevent solids sedimentation and assure homogeneization. A submersible pump, operated by a programmed timer, re-distributes the liquor to the general treatment during the whole day.

Note: this part of the plant can be fully utilized for an eventual future recycle of the liming bath. The other effluents are screened (a mechanically brushed screen is advisable in this case) and sent to the lifting station where two submersible pumps (transfer them to the equalization and sulphide oxidation basin).

The principal source of bad smell in an effluent treatment plant is the equalization tank: in fact the untreated wastes contains sulphide that can be stripped out as gaseous H_2S . Although other bad smelling products

are present, the sulphuric acid is universally recognized as the principal cause of the bad smell of tannery wastes.

In order to limit this stripping, a mixed solution has been adopted here; mechanical mixing coupled with suppressed air injection. The submersible mixers have the role of keeping the solids in suspension and the blower and diffusers that of the sulphide oxidation. In such a way, the air necessary is greatly reduced. For example, for mixing a 400 m³ basin a minimum of 1,000 Nm³/h of air is required, while the air necessary only for the sulphide oxidation (supposing an in-let of 6 kg/h of S²⁻ from the liming storage tank and a 10% oxygen transfer efficiency of the diffusers) is about 200-300 Nm³/h. Being the liming (and sulphide) dosed uniformly in the day, the catalyst (MnSO₄ in water solution) is dosed by means of a dosing pump. The consumption of manganese sulphate, industrial product, is about 20-40 mg/l. The homogenized and aerated wastes are then pumped (submersible pump) at constant flow (30 m³/h ca.) to the flocculation tank where alum (200 -300 mg/l dosage) and an anionic polyelectrolyte (0.5-2 mg/l dosage) are added by means of two dosing pump operating simultaneously with the second lifting pump. The primary sedimentation can be realized into two parallel 50 m Dortmund tanks (bottom 60 sloped) or into a circular clarifier of 7 m diam. (total volume 90 m³ ca.) equipped with mechanical sludge scraping device. The supernatant is sent to the municipal sewer net-work, while the settled sludge is pumped (temporized helicoidal pump) to the thickening tank. In order to avoid the cost of a mechanically scraped thickener, the installation of a 50 m³ cylindrical/conical tank with a submersible mixer has been proposed. The mixer will be utilized when necessary for mixing the sludge with the lime-milk or for facilitating the sludge draw-off. The sludge production has been already estimated in 2,250 kg ca. of dry matter or 55-60 m³ of liquid product. The two mechanical dewatering system utilized for tannery sludge are :

- plate filter press
- band press

The principal characteristic and advantages/disadvantages of the two systems are reported in table VIII.

Installation cost apart, the more determined aspects in the choice are:

- i. the minimal dry content of the sludge accepted in the sanitary land fills (sometimes a minimal 35% dry content is requested);
- ii. availability and cost of the polyelectrolyte.

Table VIII

	FILTER PRESS	BAND PRESS
Installation cost	more expensive	LESS
Dry content of the dewatered sludge	30-49 %	25-30%
Operation	discontinuous	continuous
Dosage of chemicals	unnecessary	a polyelectrolyte dosage (2-4 g/kg of dry material) is mandatory
Labour	labour is necessary during the filter opening and cake discharge	only little supervision
Maintenance	filtering clothes must be periodically cleaned	the normal maintenance for any mechanical equipment
Fresh water consumption	only at the end of the day (cleaning up)	necessary during the whole filtration period (10-15 m ³) at 4 Bars per 1 m of filtering cloth width

Example C : Joint effluent treatment plant for a cluster of tanneries

The advantages of a joint treatment plant are well known:

- i. economy of scale
- ii. availability of a more skilled personnel for the day-by-day operation, maintenance and control
- iii. possibility to instal a more efficient and reliable effluent treatment plant
- iv. more assurance of a proper plant operation and safety for the environment
- v. concentration in a single, properly selected area pollution from many sources; this fact also enables better control and management of other co-related environmental aspects, e.g.
 - air pollution
 - aesthetical problem
 - final sludge disposal

Furthermore, if the local municipal sewers are also treated in the joint plant, together with industrial effluents, the following further benefits exist :

- i. the presence of a significant volume of urban sewage simplifies the treatment of the tannery effluent.
- ii. the political support of the municipality will play an essential role both in realizing the plant and solving eventual future problem

The design of a joint effluent treatment plant for an industrial cluster is not an easy operation : many are the technical and economical aspects

involved, and furthermore, the installation must comply with the local policy of the territory.

From a technical point of view, the most important data to be investigated and carefully checked are :

- i. the current maximal production (industry by industry) of the cluster and any realistic future development.
- ii. the total volume of effluent sent to the joint plant (the installation of a flow-meter at the influent pipe of fresh-water in every industry seems to be the simplest system of control and, furthermore, will be utilized also in the future for the re-distribution of the cost of the joint treatment between the various utilizers.
- iii. process and chemicals more utilized in the production

The following ancillary services must also be faced.

- i. collection and disposal of the industrial solid wastes inside the factories.
- ii . installation of a pipeline (sewer net-work) only for the industrial effluents; rain waters must be separately collected and drained out.

Of paramount importance is the selection of the plant site : not too far from the industrial cluster but not too close to residential areas, geologically characteristics of soil, road system and electricity availability, etc.

The procedure of linking to the joint sewage net-work must also be studied and, in particular, the eventual pre-treatment to be imposed inside the tannery and/or limits to the maximal flow discharged.

Furthermore, to avoid problems in the future, to consider not only the volume but also the load of pollution of the effluent, in calculating the treatment's tariff applied to the single tanneries, is highly commendable.

Joint plants, in which the tariff was based only on the volume encountered big problems in treating the strong concentrated wastes coming from the tanneries and were obliged to change their criteria.

In the following example, I will try a possible design of joint effluent treatment plant for a cluster of tanneries of different size processing raw bovine hides to chrome finished upper leather.

A screening (10 mm openings) be the one imposed pre-treatment inside the factories for the protection of the sewage net-work. The maximal volume of industrial effluent be 5,000 m³ per day and further 3,000 m³ per day the urban sewage contribution (pretreated in septic tanks). The standards to be reached be are those usual for a discharge into surface waters (at the moment no limit for ammonia nitrogen).

A possible scheme of treatment is indicated in the following block flow-sheets. The proposed process is constituted by:

- A classical pre-treatment (screening, equalization, catalyzed sulphide oxidation, pH-control, flocculation with alum and anionic polyelectrolyte and primary sedimentation. The spontaneous sedimentation has been proposed (as optional) in order to limit the chemicals consumption in flocculation. The sulphide oxidation is done in two phases : in the equalization basin and before the flocculation; this method assures a better control of the sulphides arriving to the biological treatment. The pH-control (acid and alkali dosage) is a mean to have a better efficiency of the flocculation process. The two separated steps of the flocculation (alum and polyelectrolyte) are also related to the process efficiency and optimal chemicals consumption.

- the urban sewage, after a precautionary screening, is mixed with the supernatant from the primary sedimentation at the inlet of the biological treatment. To mix the two streams before will represent an useless increase of the costs of the primary treatment. A balancing/storage tank has been foreseen for the sewage in order to cut down the flow peaks, characteristic of these waste, that may give problems in the operation of the secondary sedimentation.

Note: if the municipal sewer receives both urban and rain waters, a maximal flow admissible to the plant must be fixed (this procedure is usual for urban effluent treatment plants).

- the biological treatment is an activated sludge process with sedimentation and sludge recycle. Due to the presence of ammonium salts in the tannery effluent and phosphates in the urban sewage, a dosage of nutrients seems not necessary.

- the produced sludges (spontaneous, chemical and biological) are sent to preliminary thickening; a dosage of lime-milk at the inlet of the thickener is recommended in order to improve the sludge sedimentation and limit the risk of bad odour. A further sludge conditioning (iron or aluminium salts/polyelectrolyte) has been foreseen; with this size of plants the possibility of a dosage of chemicals before the final dewatering is advisable also when filter presses are utilized. The supernatant from the thickener and the filtration waters must be pumped back to the general treatment (usually they are sent into the equalization basin). To disregard or underestimate these waters (often they represent 30-40% of the total influent volume) in the plant design is a big mistake to be absolutely avoided.

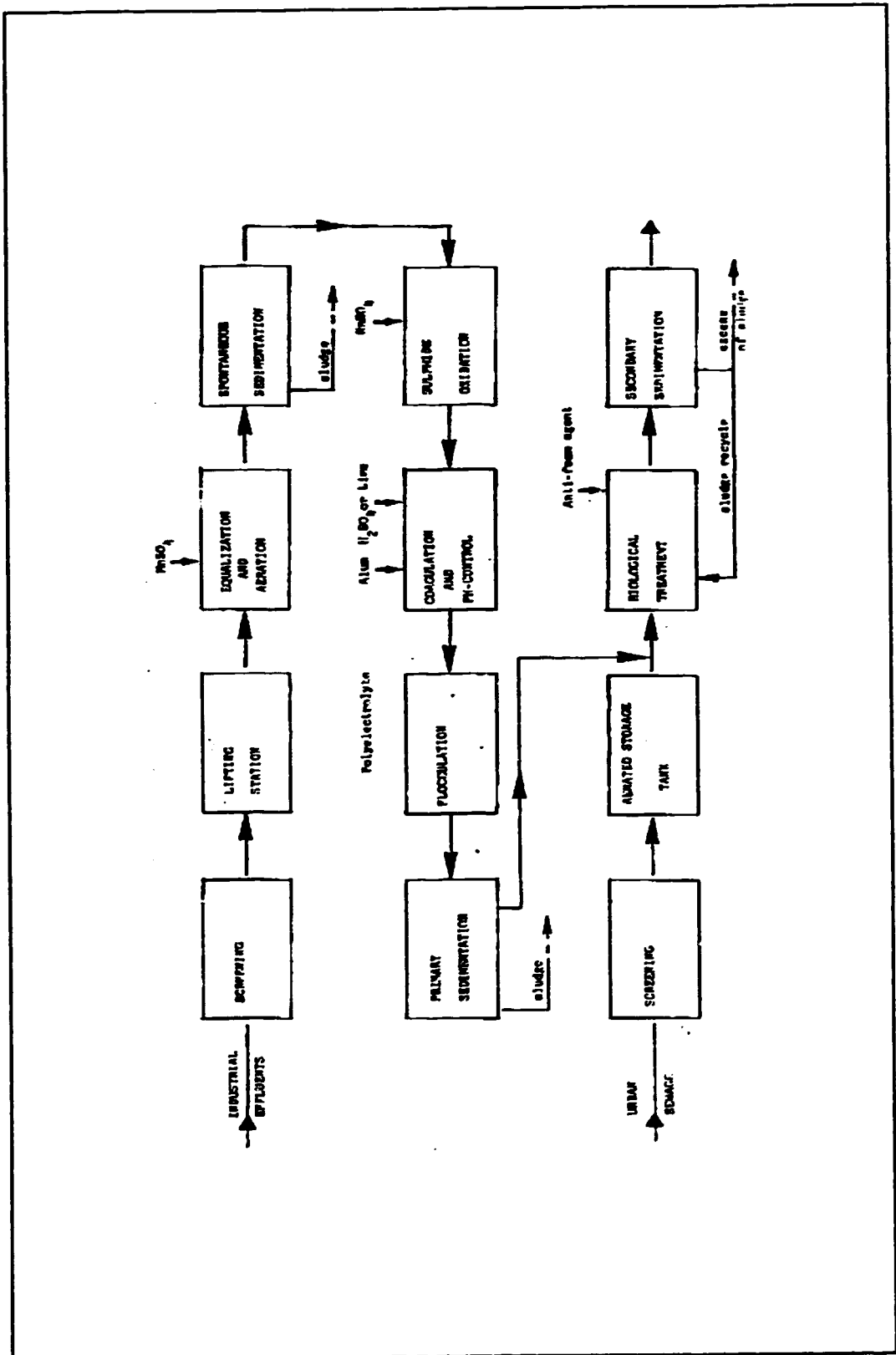

Figure 6

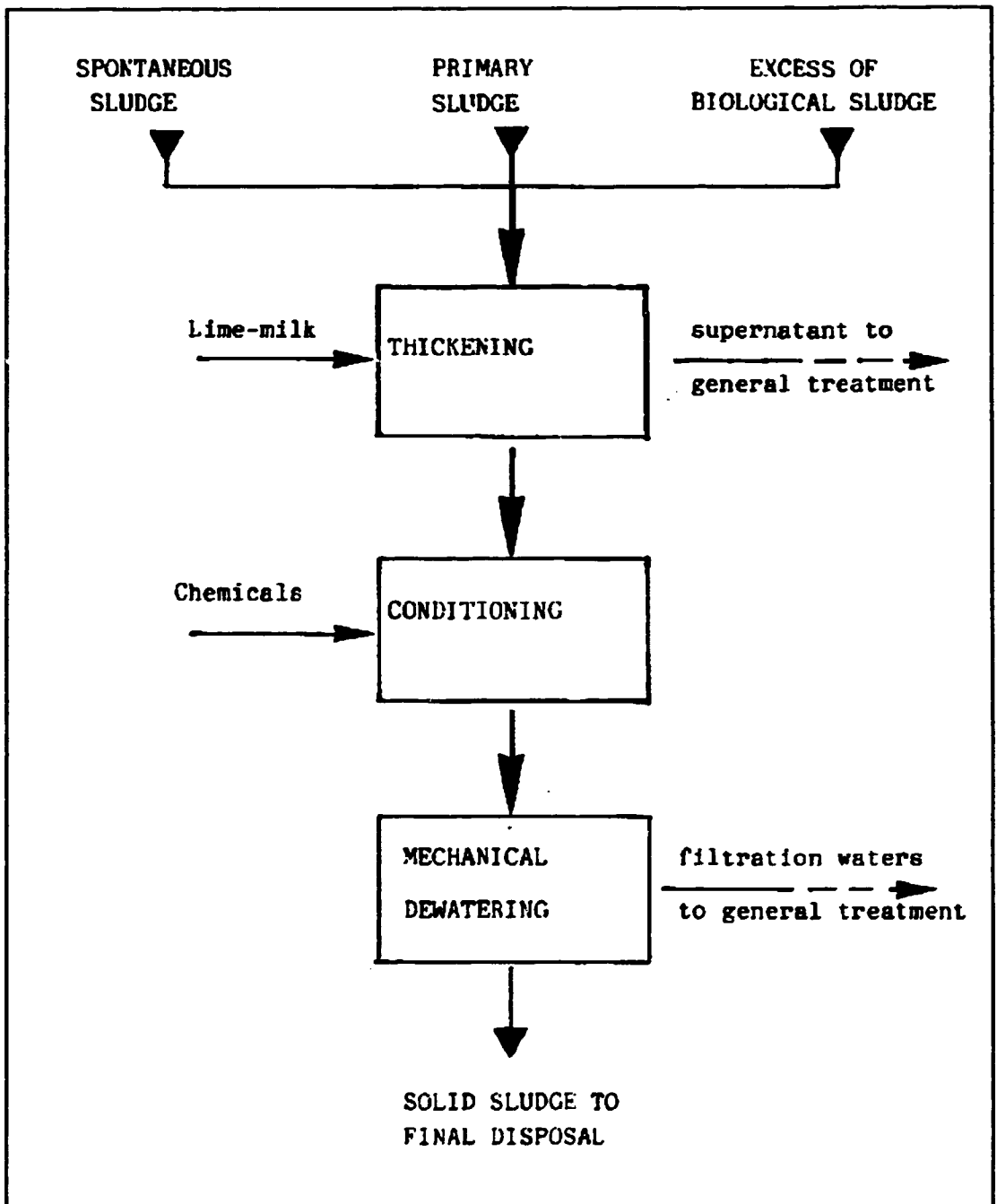

Figure 7

V. SLUDGE PRODUCTION, TREATMENT AND DISPOSAL

In conclusion, a few notes on the sludge, the biggest problem of a tannery effluent treatment:

In the classic treatment (primary + secondary) about 70-80 per cent of the sludge is produced in the primary treatment and the remaining 20-30 per cent in the secondary. The mean values for different types of tannery's process are reported in table IX.

Table IX

Process	Primary sludge production		Total sludge production	
	kg DM per kg of hide	liquid sludge 4% DM, litres per kg of hide	kg DM per kg of hide	liquid sludge 4% DM, litres per kg of hide
pulp hair and chrome tanning	0.08-0.12	2.0-3.0	0.10-0.15	2.5-3.8
pulp hair vegetable tanning	0.08-0.10	2.0-2.5	0.1-0.13	2.5-3.3
hair save or wet-blue previously tanned	0.03-0.04	0.8-1.0	0.04-0.05	1.0-1.3

Note - DM - dry matter (dry content)
 - indicative average data on the base of experimental values

The moisture content at the various steps of production or treatment of the sludge indicatively are:

- spontaneous : 92-96%
- primary : 95-97%
- secondary : 98-99%
- mixed (primary + secondary) : 96-97%
- thickened (by gravity) : 92-95%
- thickened (mechanically) : 90-94%
- filter pressed : 65-70%
- band pressed : 70-75%
- dried in sand beds (**) : 75-80%
- dried in lagoons (**) : 80%

** these values are highly variable depending on the sludge layer height, the total dewatering time and the season; in practice a sludge may be considered dewatered when it can be taken up with a shovel : minimum dry content about 20 - 25%.

The possible solution of dewatering and disposal are dependent on both the sludge characteristics and its quantity. In my opinion, sand beds can be reasonably suitable (other considerations apart) only for tanneries with a maximal production of 30-40³ m per day of liquid sludge (approx. 10-15 beds of 10 x 20 m each are required) and also in these cases, when possible, the

installation of sludge lagoons must be preferred : quite the same performances of drying beds with lower installation costs and easier reutilization of the area in the future. In all the other cases, the one alternative is the mechanical dewatering by means of filter-press or band-press(see page 27). Although the tannery sludge cannot be considered hazardous waste (the E.E.C. directive of 20 March 1979 does not indicate trivalent chromium in its list of chromium in its list of the toxic and hazardous substances - only exavalent chromium is included) the final disposal represents a big and difficult problem.

Several technical solutions to re-use these materials have been proposed but, until now, no well proven alternatives for large-scale plants exist; the only disposal method used in Europe is land fill.

Among the alternative solutions, the best known are:

- incineration
- in agriculture, as fertilizer
- in brick production
- in anaerobic digestion (bio-gas production)

The incineration has been proposed both for reducing the volume of material to be disposed into land fills and for chrome and heat recovery, but due to the very high installation cost and the risk of a new source of air pollution, no example exists of this method applied only to tannery wastes.

Whereas the technical possibility of using tannery sludge for brick production (10-15 per cent on clay weight) has been proven, the economic validity of this process is still in doubt.

For the present, the sludge treatment by anaerobic digestion does not seem to be a technique economically applicable on industrial scale because of the high content of inorganic matter and the presence of potentially toxic substances (e.g. Cr^{3+} and sulphates may hinder the anaerobic process).

The only alternative which deserves to be mentioned on the ground of recent progress (even if still on experimental level) is the use in agriculture. Furthermore, this solution is considered to be particularly suitable to conditions in many developing countries (large country areas) and, if well carried out and controlled, it could prove to be closing the "production-depollution" circle.

The most recent information about agricultural use of tannery sludges concerns the results obtained in Italy after a parallel two-year experiment carried out by the universities of Pisa and Piacenza and financed by two important joint treatment plants for tannery effluents located in Tuscany (S. Croce sull'Arno and Ponte a Egola).

Table X shows the characteristics of the sludges (primary + secondary) produced by these plants.

Table X

Parameter	S. Croce s.Arno ¹ %	Ponte a Egola ² %
Total residue on evaporation 105° C	38.30	32.00
pH in distilled water	9.10	7.80
Total fixed residue 550° C (**)	61.00	57.20
Total volatile residue (organic matter) (**)	39.00	42.80
Organic carbon (springler-Klee) (**)	21.00	22.00
Total nitrogen (**)	2.10	2.20
Total P ₂ O ₅ (**)	0.42	0.40
Total K ₂ O (**)	0.01	0.20
Total CaCO ₃ (**)	41.40	38.10
Chromium VI ^o (**)	absent	absent
Total chromium (extraction with HCl 6N) (**)	2.23	0.33

** on dry substance.

¹ centralized plant treating for the most part chrome tannery effluents;
sludge dewatering system : FILTER-PRESS

² centralized plant treating for the most part sole tannery effluent;
sludge dewatering system : BAND-PRESS

The cultivations subjected to treatment were : Indian corn, wheat and rice and the quantities of sludge employed as fertilizer were on an average about 40 tons/hectare (one application).

The first results of these tests have been published as indicative due to their being preliminary data :

- i. the fertilizing value of tannery sludges is not negligible;
- ii. the chrome content in the plant remains within physiological values
- iii. the chrome content of the soil has shown an increase (particularly using the sludge of S. Croce) in comparison with the soil treated with mineral fertilizer.

For this last reason, more and more efficient methods for the effective use of the chrome within the tannery (high exhaustion tanning methods and/or recovery) are recommended in order to limit its content in the residual sludge.

This agrees with the sanitary regulations of many countries which set limits to the quantity of trivalent chromium disposal onto the soil (see table XI).

Table XI

**Use of Chromium III containing sludge on land
European acceptance levels**

	Max. Cr content of sludge, mg/kg	Max Cr content of soil, mg/kg	Cr added to soil kg/ha per year
ITALY	500	50	2/year
FRANCE	200	150	30-10 years
SWITZERLAND	1,000		
WEST GERMANY	1,200	100	
POLAND	1,000		
HOLLAND	500		100/80-100 years
SWEDEN	1,000		1/year
FINLAND	1,000		4/year
UNITED KINGDOM			1000/30 years
E. E. C. DIRECTIVE (proposed)	750	50	100/10 years

BIBLIOGRAPHY

1. R.B. SCHAFFER; D.F. ANDERSON; B.G. ERNST.
Development Document for Effluent Limitation Guidelines and Standards.
Leather Tanning and Finishing Point Source Category.

U.S. Environmental Protection Agency, Washington D.C., July 1979
2. M. ALOY; A. FOLACHIER; B. VULLIERMET
Pollution of Tannery.

Centre Technique du Cuir, Lyon - France, May 1986
3. D. WINTERS.
Techno-Economic Study on Measures to Mitigate the Environmental Impact of
the Leather Industry. Particularly in Developing Countries.

Edited by UNIDO, April 1986
4. O. MISCHITZ.
Hair-Save Liming Process: Helping to Reduce the Effluent Load.
Paper presented at the International Workshop on Chemistry and Technology
of Tanning Process, S. Miniato (Pisa), June 1988.
5. ANDIS (Associazione Nazionale di Ingegneria Sanitaria).
Acts of the Workshop on the Utilization of the Residual Sludge from
Tannery Effluent.
S. Miniato (Pisa), November 1989
6. UNIONE NAZIONALE INDUSTRIA CONCIARIA
Atti Convegno Internazionale sul Recupero di Risorse dalla Depurazione
Conciaria.
Milano, January 1987
7. STAZIONE SPERIMENTALE PER L'INDUSTRIA DELLE PELLI E DELLE MATERIE CONCIANTI
Utilizzazione e Smaltimento dei Fanghi Conciari.

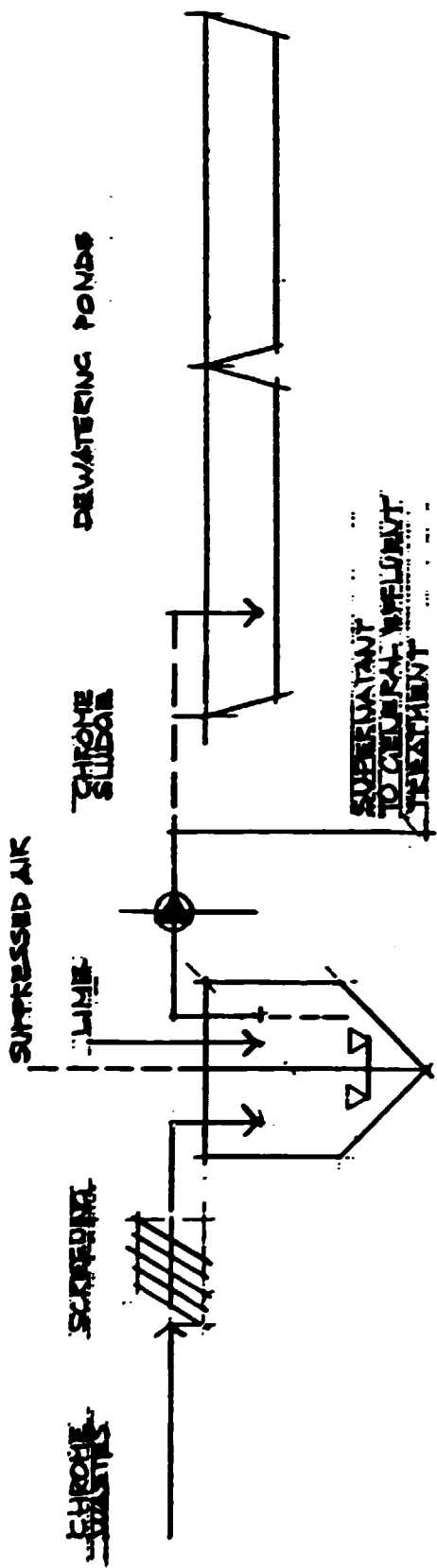

EXAMPLE A
CHROME WASTE TREATMENT

SUDGE DEWATERING LAGOONS

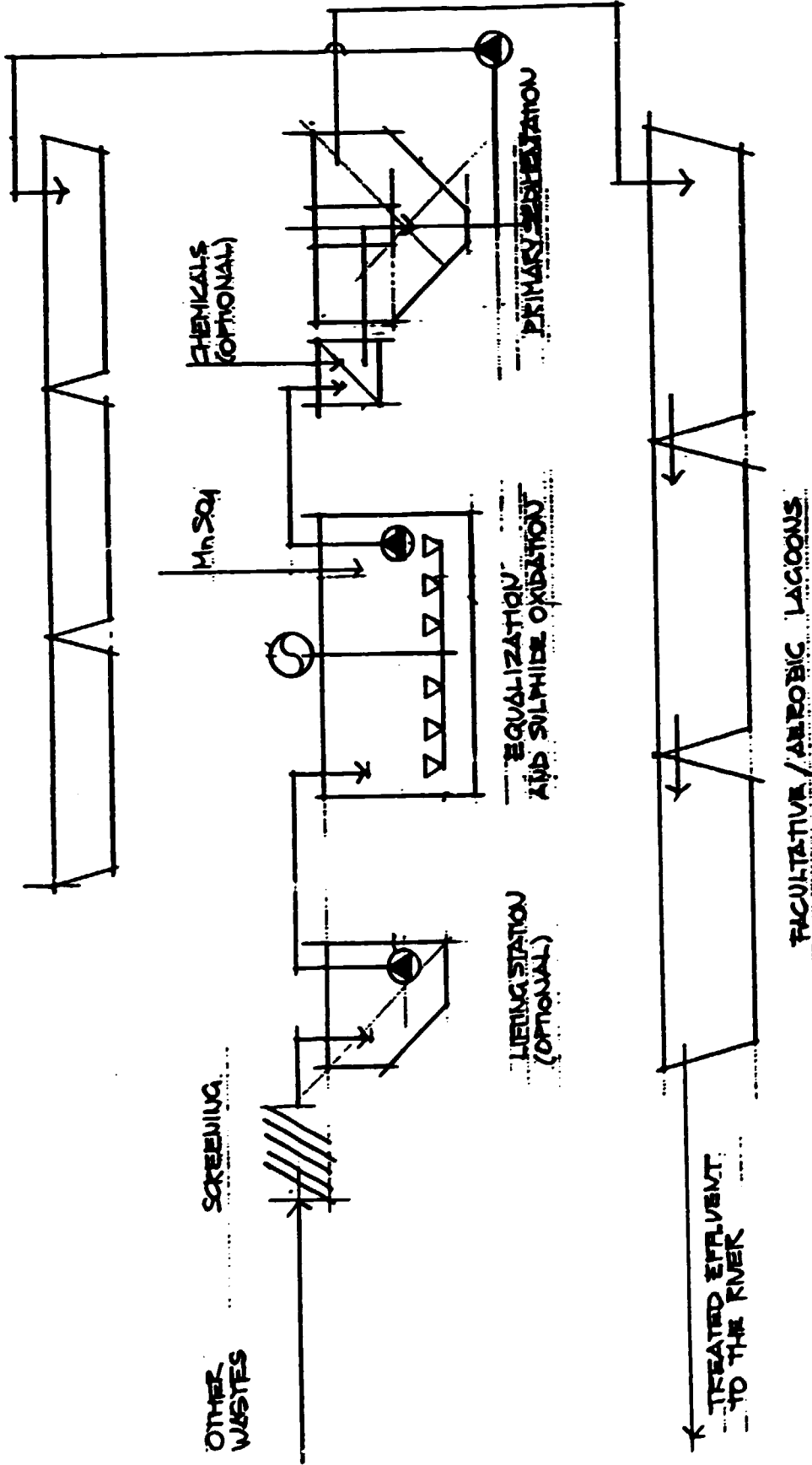

EXAMPLE A
GENERAL EFFLUENT

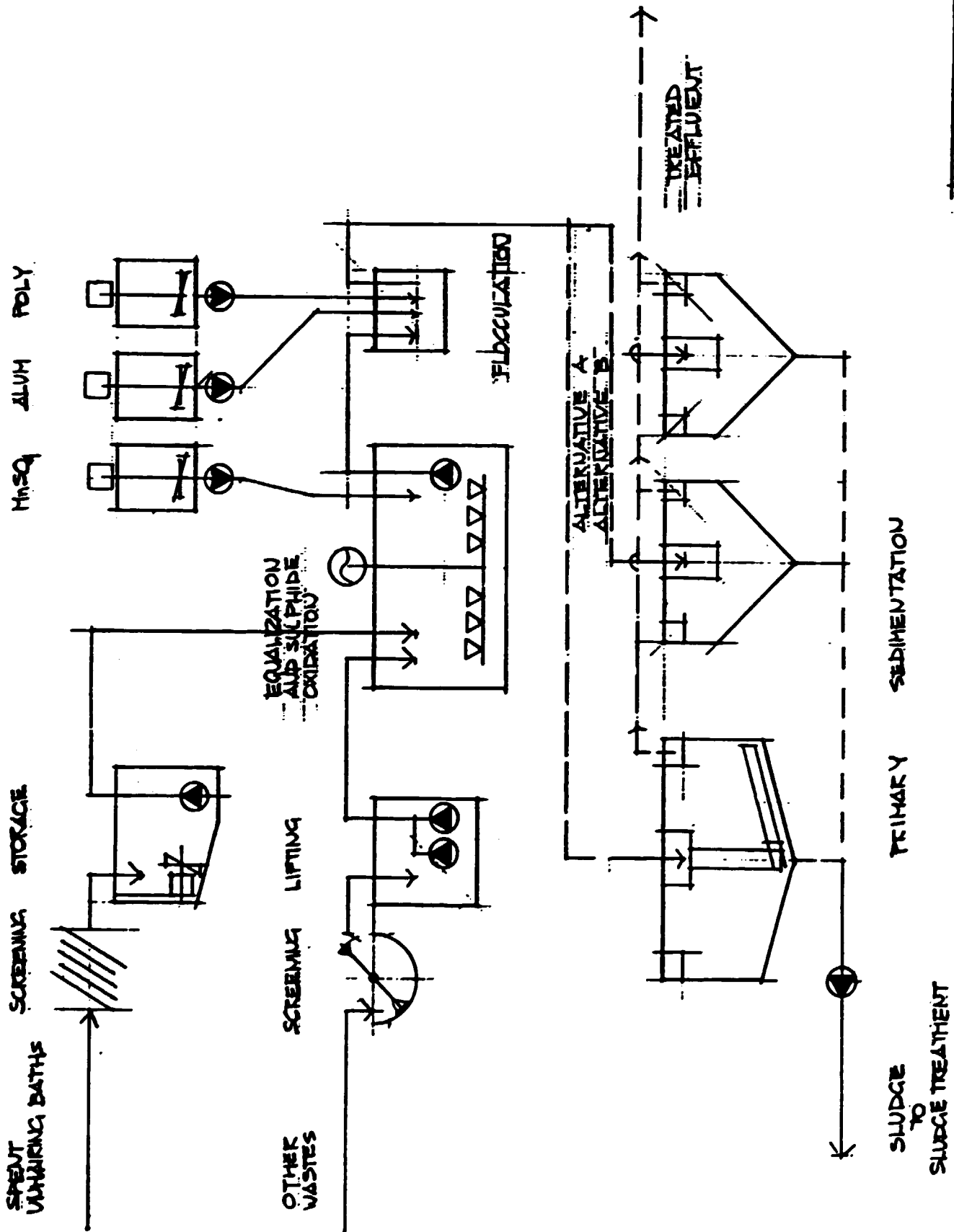

EXAMPLE B
PRIMARY TREATMENT

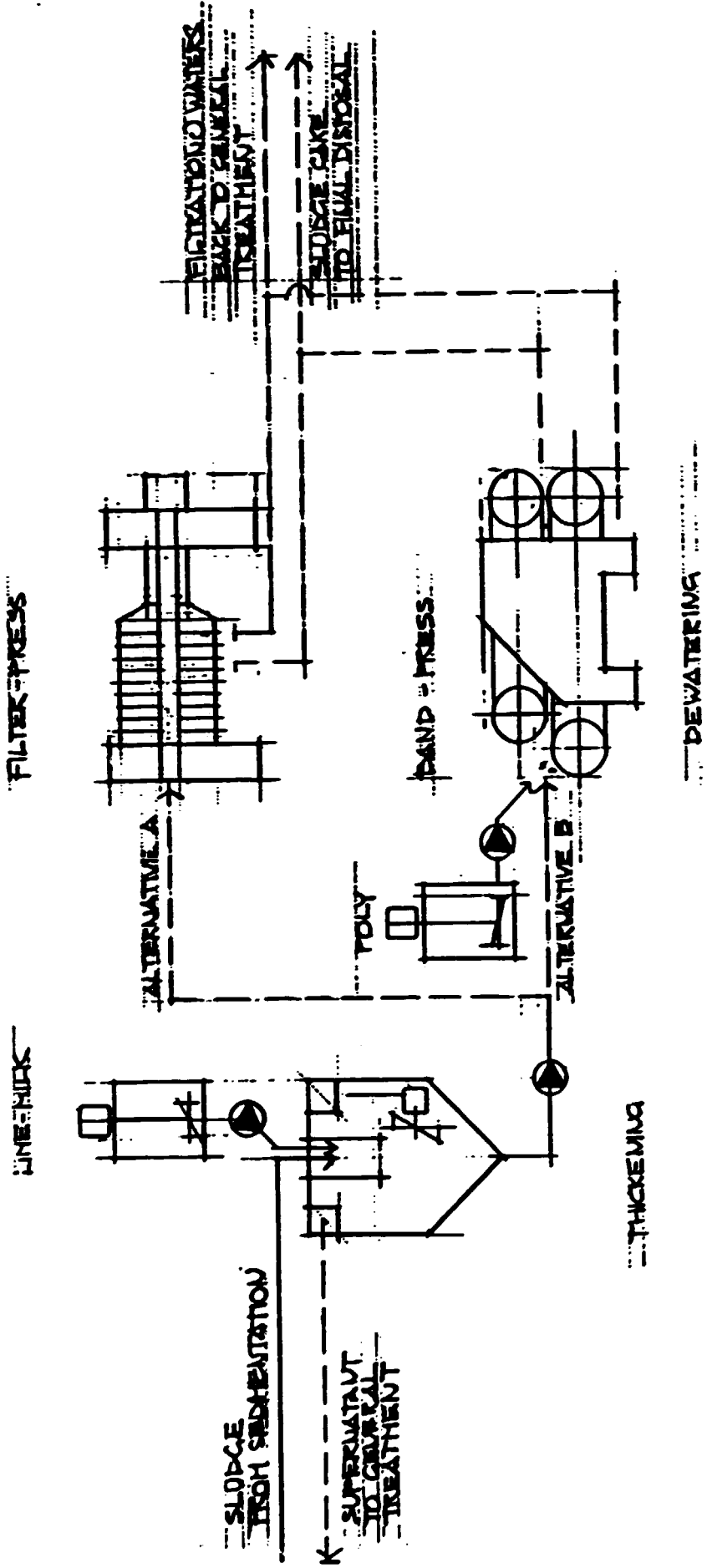

EXAMPLE
SLUDGE TREATMENT

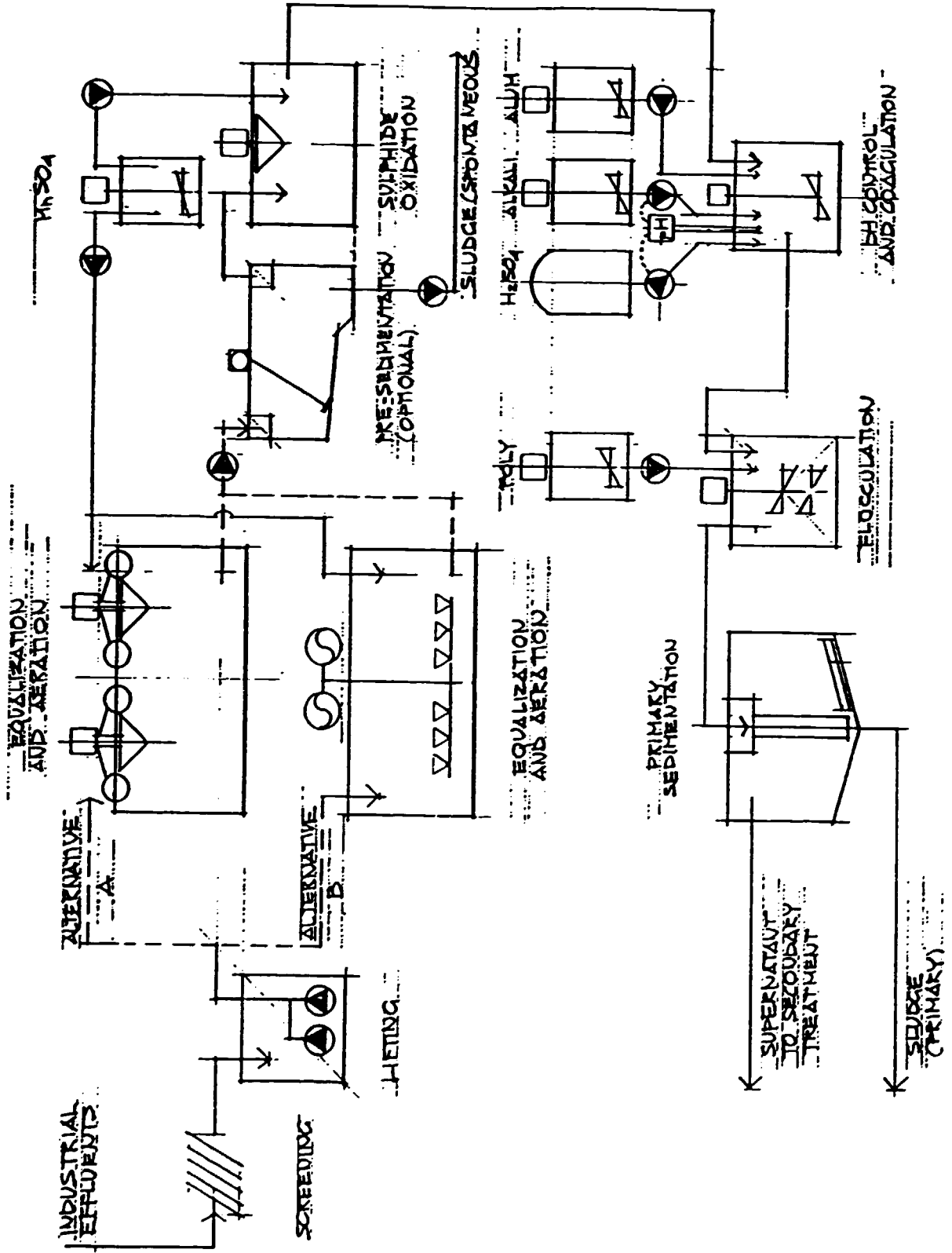

EXAMPLE C
PRIMARY TREATMENT

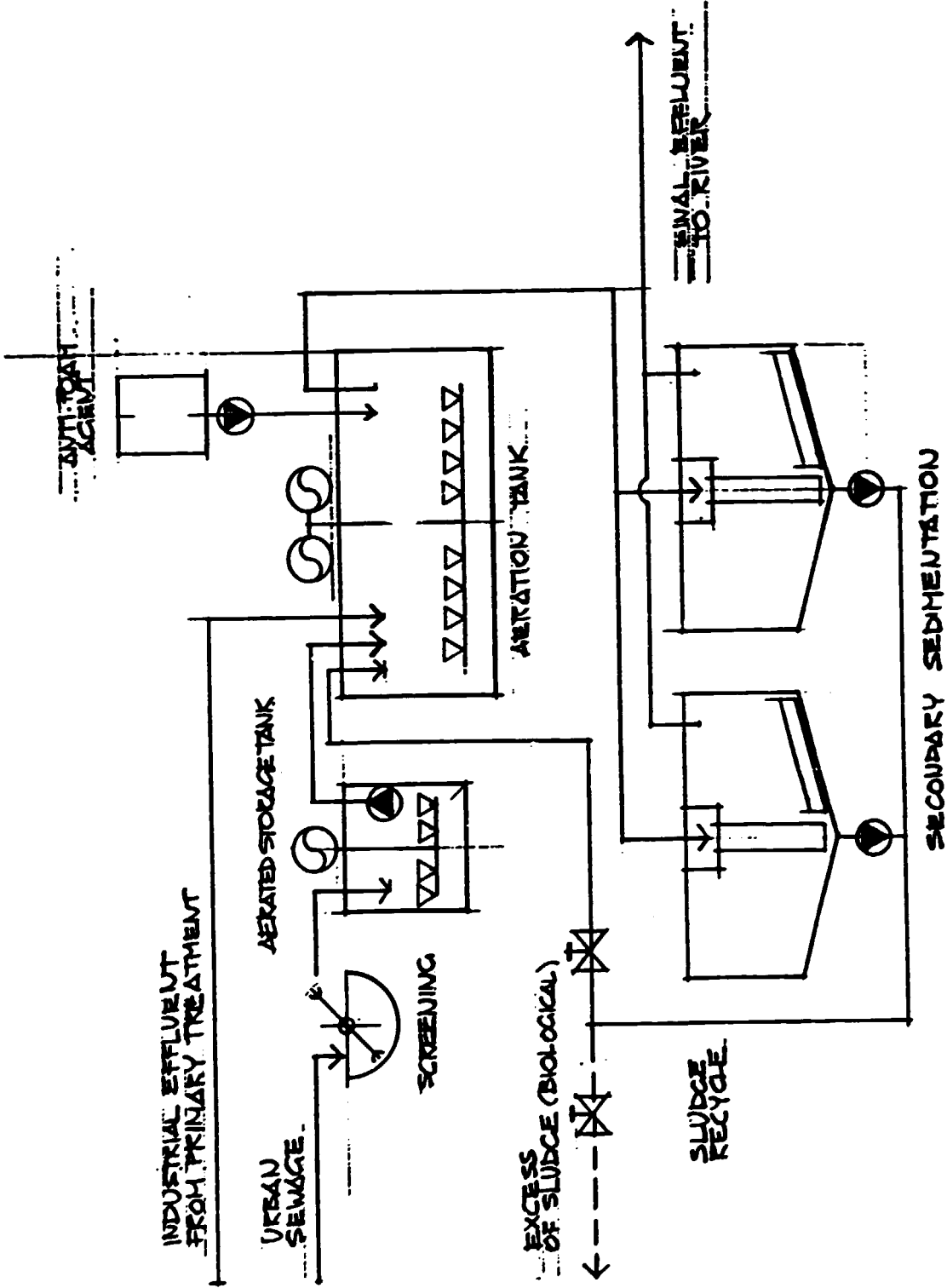

EXAMPLE 2
SIPROSAZ TRATHEIT

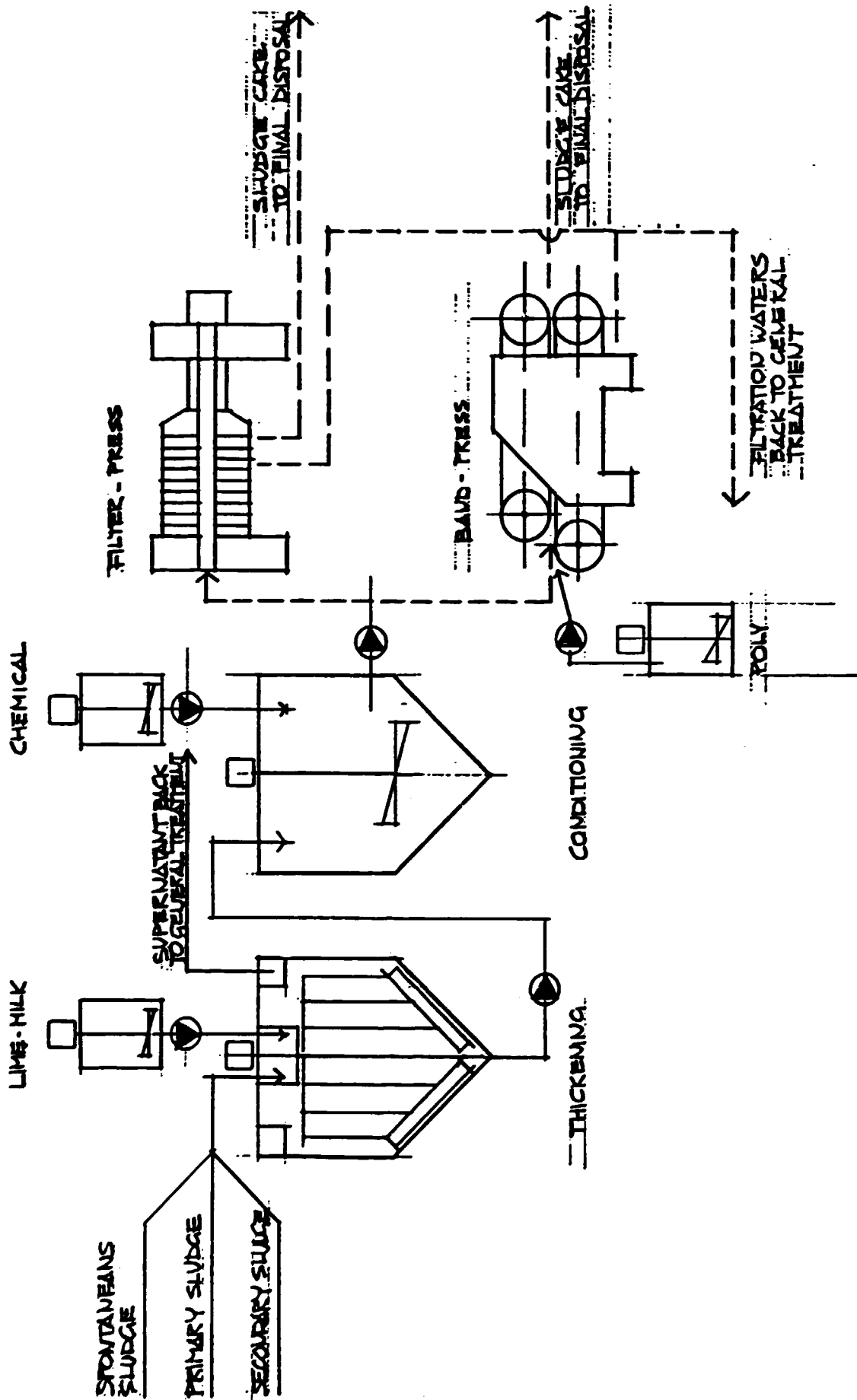

EXAMPLE C
SLUDGE TREATMENT