



TOGETHER
for a sustainable future

OCCASION

This publication has been made available to the public on the occasion of the 50th anniversary of the United Nations Industrial Development Organisation.



TOGETHER
for a sustainable future

DISCLAIMER

This document has been produced without formal United Nations editing. The designations employed and the presentation of the material in this document do not imply the expression of any opinion whatsoever on the part of the Secretariat of the United Nations Industrial Development Organization (UNIDO) concerning the legal status of any country, territory, city or area or of its authorities, or concerning the delimitation of its frontiers or boundaries, or its economic system or degree of development. Designations such as “developed”, “industrialized” and “developing” are intended for statistical convenience and do not necessarily express a judgment about the stage reached by a particular country or area in the development process. Mention of firm names or commercial products does not constitute an endorsement by UNIDO.

FAIR USE POLICY

Any part of this publication may be quoted and referenced for educational and research purposes without additional permission from UNIDO. However, those who make use of quoting and referencing this publication are requested to follow the Fair Use Policy of giving due credit to UNIDO.

CONTACT

Please contact publications@unido.org for further information concerning UNIDO publications.

For more information about UNIDO, please visit us at www.unido.org



UNITED NATIONS
INDUSTRIAL DEVELOPMENT ORGANIZATION

19267

**TECHNICAL AND ECONOMIC ASSESSMENT OF
THE VIABILITY OF REACTIVATING /
COMMISSIONING THREE INCINERATOR PLANTS
IN LAGOS - NIGERIA**

FINAL REPORT

February 1991

**Contract No.: 90/075
Project No.: SI/NIR/89/806**



Rome ITALY

186p.
table
diagram
map
index

2037



UNITED NATIONS
INDUSTRIAL DEVELOPMENT ORGANIZATION

**TECHNICAL AND ECONOMIC ASSESSMENT OF
THE VIABILITY OF REACTIVATING /
COMMISSIONING THREE INCINERATOR PLANTS
IN LAGOS - NIGERIA**

FINAL REPORT

February 1991

**Contract No.: 90/075
Project No.: SI/NIR/89/806**

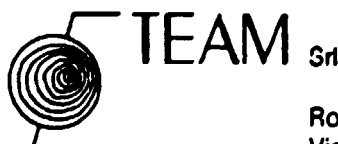

Rome ITALY
Via Porpora, 12
Tel.: (6) 8450370
8416468
Telex: 613242 TEAM
Fax: (6) 8450371

EXECUTIVE SUMMARY

	Page N.
- Project Background	1
- Project Activities	2-3
- Recommendations and Conclusions	4-7

REPORT CONTENTS

1. Introduction	8
2. Impacts of incineration	9-16
3. Evaluation of the process technology employed in the incineration plants of Lagos	17-18
4. Current status of the installed plants and estimated cost of making the plants operational	19-138
5. Status of municipal solid waste handling and management in Lagos	139-167
6. Assessment of possible scenarios	168-179
7. Economic evaluation and analysis of the suggested scenarios	180-185
8. References	186

TABLES

1	Air Pollutants	11
2	Limits of pollutants emission (Switzerland)	14
3	Limits of pollutants emission (Italy)	15
4	Pollutants emission from "Busto Arsizio" Incinerating plant (Italy)	16
5-a	Proposed Scenario OPTION A	171
5-b	Proposed Scenario OPTION B	173
5-c	Proposed Scenario OPTION C	175
6	Waste Heat Recovery Unit	176
7	Incineration Plants Flow Scheme	177
8	Flue Gas cleaning system	178
9	Improved compost & Refining Scheme	179

FIGURES

A	Human exposure to atmospheric emission	12
B	Human exposure to chemicals in ash residue	13

EXECUTIVE SUMMARY

PROJECT BACKGROUND

During the visit of UNIDO team to Nigeria in 1989, the Ministry of Commerce and Industry of Lagos State Government brought to the team's attention the need for a technical and economic appraisal of the three incinerating plants in metropolitan Lagos to be undertaken promptly.

In view of the priority accorded the collection and disposal of waste all over the world, UNIDO proposed a project consisting of two major objectives.

The first purpose of the project is to provide adequate information on the present status of the plants and machinery by assembling and collating technical data obtained by physical inspection of the plants in their present state and consequently determine the estimated cost of their rehabilitation.

The second purpose of the project is to examine the technical/economic feasibility of rehabilitating, commissioning and operating the three incinerating plants and attendant environmental consequences.

It is the intention that on the completion of the above stated assignments, the Nigerian authorities will be presented options for their consideration.

PROJECT ACTIVITIES

Perusal and scrutiny of available documents

Examination and scrutiny of the available documents represented an important assignment in the appraisal of the waste incinerators.

The experts noted that most of the files and vital documents concerning proposals and awards of the contracts for the implementation of the plants were untraceable.

While partial technical documentation (design, specification) was available for the Claudius Peter plants they could not be located for the Marini plant. This was due to many changes which occurred over the years in the offices responsible for the plants. However the scrutiny of the available documents carried out during the first mission of the experts to Nigeria has been of great importance for the perusal, analysis and summary of technical aspects, incineration methodologies and environmental consequences especially in respect of the two Claudius Peter plants.

Technical inspection

The technical inspection of the three incinerators, extensively conducted by us, provided us with detailed knowledge on the present condition of plant and machinery including the mechanical structure of the various components. The inspection also provided us with the opportunity to ascertain in principle the state of disrepair of the plants caused by pilfering and plundering.

The three plants have been plundered almost completely of their vital electrical parts such as instrumentation, cables, motors, control panels and relative switches.

Mechanical structures were not plundered due to difficulties in dismantling and the low second hand market value for them. They have been partially damaged by rust and age over the years.

Nevertheless, due to the high cost that would be involved in the acquisition, and installation of new and similar plants and also in view of the need and importance to the public of the service which incinerators provide a rehabilitation programme of the said plants is recommended.

Our proposal is not limited to the rehabilitation of the plants to bring them to their original capabilities but includes the addition of new and modern equipment for the treatment of environmental wastes (solids and gas) and for the production of electricity.

In addition, the introduction and use of innovative technologies to improve the refining of compost, so as to attain European standards, are also recommended for the existing composting line at the Marini plant.

It is our considered opinion, that our proposed rehabilitation programme will prevent the total loss of the original investments in the plant, will considerably increase the value of the rehabilitated plants and finally will allow the Lagos State Government to provide the inhabitants of Lagos metropolis with an essential social service efficiently.

Landfills inspections

Based on our detailed inspections of the five existing landfills in Lagos metropolis, details of which are considered in the relevant chapter later on in this report, the state of solid waste collection and disposal in urban Lagos represents one of the crucial points in the consideration of the reorganization of waste collection and disposal activities in Lagos. The transformation of existing landfills into sanitary landfills and the restructuring of the collection service should form an integral part of the envisaged rehabilitation programme.

RECOMMENDATIONS AND CONCLUSION

1. GENERAL

The following main conclusions are drawn from the report herein:

Incineration should not be considered separately from other waste management options. Every decision and suggestion must be taken considering total waste management planning.

The waste management strategy should consider: reducing the amount of waste generated, reusing and recycling, treatment of waste and using land disposal for any treatment residuals and remaining waste.

Careful and continuous monitoring of incineration plants is the key to reducing the risks of toxic air emissions. The best technology is of little use if plants are not run adequately. The training of operators must be considered as one of the most important aspects of the plant operations.

Incineration facilities can help to reduce waste volume by as much as 80% and permit the conversion of heat generated by the combustion process into electricity or steam.

Any rehabilitation programme must include the improvement of the existing plants with the addition of waste heat recovery and flue gas cleaning units, in order to bring the plants to the present level of the guidelines concerning environmental protection.

The "Claudius Peters" (Simpson Street) and "MARINI" plants can be revamped while Claudius Peter (Odaliki Street), due to its location in the middle of a residential area, should be converted into a community centre.

The conversion of one plant area to a transfer loading station could be very useful.

A direct connection between the highway and plant facility at Simpson Street is necessary in order to facilitate the access of trucks: this should not present any particular difficulty.

The revamping of the existing compost line is very important to reduce the amount of waste and to obtain a commercial viable product.

The sale of the three plants as scrap metal, intentionally, has not been carefully analysed.

This option, which we do not recommend, will, firstly, deprive Lagos Municipality of the necessary infrastructures to provide one of the most essential service for the inhabitants, secondly, due to the negligible income coming from the sale of the scrap metal, will procure a nearly total loss of the initial capital investment

This report strongly recommends that Authorities in charge decide, as soon as possible, the future of these three incineration plants, in order to avoid their further deterioration and improve on municipal solid waste management in Lagos.

2. POSSIBLE OPTIONS

Based on the technical assessment of the incinerators and on the actual waste management system, the following alternative options have been indicated:-

A) Rehabilitation of "Claudius Peters " plant in Simpson St.

Reactivation of the compost line of the Marini plant and conversion of the area into transfer loading station.

Use of the "Claudius Peters" plant in Odaliki St. as spare parts and possible use of its concrete structure as public building.

B) Rehabilitation of "Marini Plant" (inceneration and compost line).

Partial use, as spare parts, of "Caludius Peters" plant in Simpson St. (mainly electric power generating units) and conversion of the area into transfer loading station.

Use of the "Claudius Peters" plant in Odaliki St. as spare parts and possible use of its concrete structure as public building.

C) Reactivation of the compost line in "MARINI Plant" and conversion of this area into transfer loading station.

Reutilization of electric power generating units of the "Claudius Peters" plant in Simpson St. and conversion of this area into transfer loading station.

Use of the concrete structure of the "Claudius Peters" plant in Odaliki St. as public building.

Sale of the remaining equipment.

The above mentioned three options have been foreseen in an integral planning for which existing landfills and waste water treatment system, should be included.

3. CONCLUSION

In order to minimize the enviromental impact of the restructured plants, the three possible options have been based in respect of the recent standard regulation for the maximum limit of the polluting emissions.

Besides, to reduce the risk of toxic air emissions and to convert heat generated, into appreciable quantity of electric power, the best available technology have been adopted.

A) This option, due to a near complete revamping of the existing plants, is the most advisable from the technical point of view.

B) This option maintains an appreciable technical value, while the total cost investment is slightly reduced.

C) This option is the most appreciable, from the cost investment point of view, but technically inadequate to solve all problems of the waste management in Lagos State.

In the schedule herein, are briefly described benefit and disadvantage of each option:

OPTION	ADVANTAGES	DISADVANTAGES
A	<ul style="list-style-type: none"> - Total reconditioning of the existing plants - Income from the sale of electric power = at the operating costs of the plant - Possibility of future expansion of the plants (hazardous waste treatment unit) - Optimization in the waste managment system 	<p>Highest cost investment</p>
B	<ul style="list-style-type: none"> - Partial reconditioning of existing plants - Plants and additional technological line located in one area only - Sufficiency in the waste managment system 	<p>Considerable cost investment</p> <p>High operating costs</p> <p>Future expansion of the plant, not possible</p>
C	<ul style="list-style-type: none"> - Minimum cost investment - Minimum operating costs 	<p>Minimum reconditioning of the existing plants</p> <p>Waste managment system not integrated and not sufficient</p>

1. INTRODUCTION

The treatment and disposal of urban solid waste is considered all over the world as one of the essential services to be provided by Municipal Authorities.

The rate of environmental degradation and pollution in urban centers has necessitated the enactment of strict sanitary rules and regulations for the disposal and control of urban solid wastes thereby introducing several methods aimed at reducing or outright elimination of potential environmental hazards.

One of these methods is the use of sanitary landfills which has proven inadequate for the treatment of urban solid waste. On the other hand an integrated system of collection, transfer and incineration has demonstrated its appropriateness and effectiveness.

The present system of solid waste disposal in urban Lagos is inadequate and the situation very critical.

However a radical restructuring of existing structures to bring about a more efficient and responsive system will ensure that minimum established sanitary and health standards are met.

This study therefore has taken into consideration the technological processes of the existing incinerating plants in urban Lagos, the present state of these plants, the actual system of solid waste disposal and the required transformation of the existing plants in order to provide a comprehensive idea of the present situation and all the possible alternatives.

These alternatives have been extensively elaborated on and their economic and financial viability evaluated in chapters six and seven.

2. IMPACTS OF INCINERATION

Incineration is not a new technology; many Municipal Solid Waste (M.S.W.) incineration facilities have been in operation for over 50 years. Increased concern about the quality of the environment lead to improvements in the design of incineration units.

The identification of potentially hazardous chemicals associated with incinerating operations can be summarized as follows:

a) Stack emissions

The pollutants generated by the combustion of M.S.W. have been categorized as criteria pollutants, acid gases, heavy metals and organic material. (See tab. 1) (Ref.1).

b) Solid ash residue

This solid waste is in the form of fly-ash and bottom ash. It is 20% to 40% of the initial volume of unprocessed M.S.W.

The risks to human health caused by M.S.W. incineration can be evaluated by the potential pathways of human exposure to atmospheric emissions and to chemicals in ash residue. (See fig. A and fig. B).

This evaluation, however, requires a great deal of data to estimate exposure and to express numerically chemical toxicity. These data have improved over the past decade, but considerable uncertainties still exist and they are:

- The lack of long-term emissions data for M.S.W. incinerator
- The lack of ambient monitoring data for M.S.W. incinerator
- Limit toxicity data for some of the chemicals of greatest concern. For example the potential cancer risks result from exposure to PCDD and PCDF. At present, the only data are derived from high-dose laboratory animal experiments. The data must be extrapolated to examine low-dose, human cancer risk.

A recognition of the risks posed by M.S.W. incineration have already begun to impact the design and the operation of proposed facilities. The current trend is to continue in the development of more sophisticated method for the risks estimation and, at the same time, to upgrade incinerator performance standards and risks management regulations.

In a properly designed incinerator, any known toxic material can be converted into harmless combustion products. This depends on proper maintenance and operation of the units.

Due to above mentioned aspects, the following aims are taken into account in the most recent designs of M.S.W. plants:

- achievement of optimum temperatures to ensure complete combustion
- minimization of pollutants emissions
- increase of waste heat recovery to accomplish operating costs saving and the production of electricity.

A typical M.S.W. incineration plant mainly consists of three sections and in particular: incineration, waste heat recovery and flue gases and ash cleaning. Test results indicate that waste pre-sorting can benefit the mass-burning process; flue gas and ash heavy metals were found to be significantly reduced. (Ref.2)

Results from existing plants, e.g. the plant in Niederurnen - Switzerland, are compared with the limits prescribed by law. (see Tab.2), and the other in Italy (Tab.3 and 4). (Ref.3).

Moreover some M.S.W. plants are located and in operation in the centers of cities like Zurich and Munich.

The experience, from various countries in respect of the incineration of M.S.W., suggest that the incineration can be made safer and more acceptable as part of a comprehensive waste management program that also include waste reduction, recycling, the use of waste for energy production, and, most importantly strict regulation, monitoring and accountability.

TAB. 1

AIR POLLUTANTS

Criteria pollutants

Sulfur dioxide
Nitrogen dioxide
Carbon monoxide
Particulate material
Lead

Acid gases

Hydrogen chloride
Hydrogen fluoride

Heavy metals

Arsenic
Cadmium
Mercury
Chromium
Nickel
Lead

Organic material

Polychlorinated dibenzo-p-dioxins (PCDD)
Polychlorinated dibenzofurans (PCDF)
Polynuclear aromatic hydrocarbons

FIGURE A

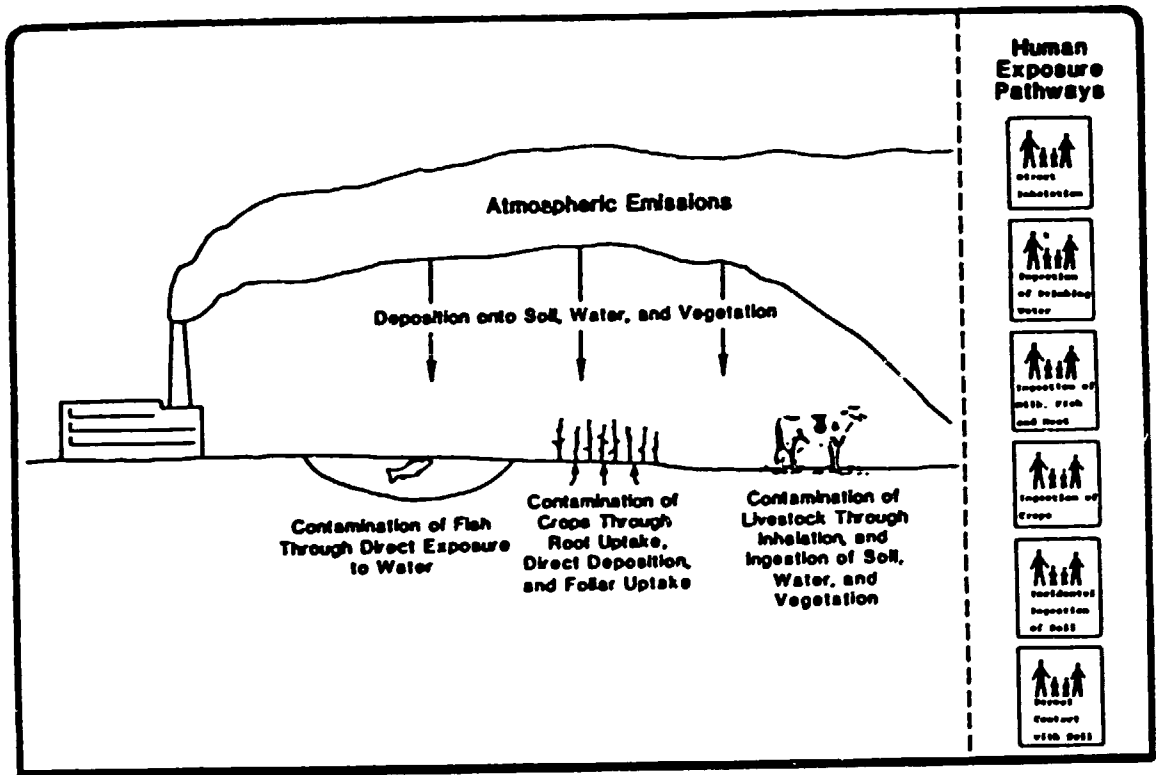

Examples of potential human exposure to atmospheric emissions
Source: ENVIRON, Counsel in Health and Environmental Science

FIGURE B

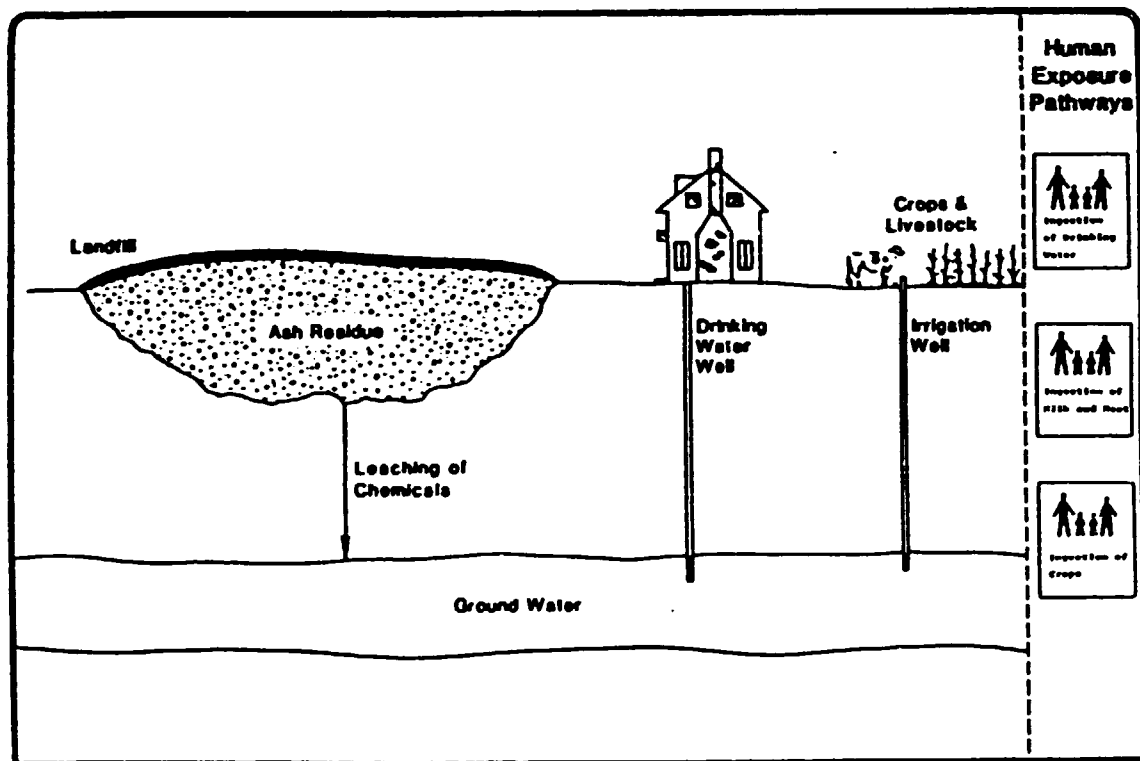

Examples of potential human exposure to chemicals in ash residue

Source: ENVIRON: Counsel in Health and Environmental Science

TAB. 2

The following limits apply in Switzerland, and hence these concentrations are used as a minimum target. All values are in mg/Nm³, based on 11% O₂ dry:

Pollutant	Formula	Limit
Hydrogen fluoride	HF	5
Hydrogen chloride	HCl	30
Sulphur dioxide	SO ₂	500
Nitric oxide	NO ₂	500
Mercury	Hg	0.1
Zinc and lead	Zn + Pb	5
Cadmium	Cd	0.1

These values are taken from "Luftreinhalte-Verordnung" (LRV), 16th December, 1985.

The following results are from an existing plant in Niederurnen:

Pollutant	Content (mg/Nm ³ , 11%O ₂ dry)		% removal
	original	purified	
HF	7	0.02	99.7
HCl	980	8	99.2
SO ₂	140	18	87.1
NO ₂	500	430	14.0
Hg	0.4	0.04	90.0
Dust	2000	4	99.8

TAB. 3

LIMITS PERMITTED IN ITALY

Total fly ash	
- avg value	40 mg/Nm ³
- peak value	50 mg/Nm ³
Total heavy metals	
- Lead	3 mg/Nm ³
- Cadmium	0.1 mg/Nm ³
- Mercury	0.1 mg/Nm ³
Total organic carbon	10 mg/Nm ³
Polychlorinated compounds	
PCDD + PCDF	0.01 mg/Nm ³
TCDD + TCDF	0.05 mg/Nm ³
PCB + PCN + PCT	0.1 mg/Nm ³
Polynuclear aromatic hydrocarbon	0.05 mg/Nm ³
Cianide (as HCN)	0.5 mg/Nm ³
Hydrogen chloride	50 mg/Nm ³
Flydrogen fluoride and bromide	3 mg/Nm ³
Phosphorus (as P₂ O₅)	5 mg/Nm ³

TAB. 4

DATA FROM BUSTO ARSIZIO INCINERATING PLANT

Operating Data		Stack	After Postcombustion
Temperature (°C)		203	1000-1050
Flue gas Flow rate (Nm ³ /h dry basis)		58.035	
Particulate conc.n (mg/Nm ³ dry basis)		11 (18.6)(*)	
Flue gas composition	O ₂ (%)	13.5	
	CO ₂ (%)	7	
	CO(ppm)	6 (10)(*)	
Heavy metal concentration in flying ash (mg/Nm ³ dry basis)	Pb	inf.3	
	Cd	inf.0.1	
	Hg	inf.0.1	
Pollutants concentration	HCl	23	950
	SO ₂	9 (15)(*)	
	NOx	62 (105)(*)	
Dioxine (mg/Nm ³ dry basis)	4-CDD	0.0023	
	4-CDF	0.088	
	4-CDD+4-CDF	0.0903	
	5-CDD	0.0006	
	5-CDF	0.0033	
	5-CDD+5-CDF	0.0039	
	6-CDD	0.0043	
	6-CDF	0.002	
	6-CDF+6-CDF	0.0063	
	7-CDD	0.0023	
	7-CDF	0.0008	
	7-CDD+7-CDF	0.0031	
	8-CDD	0.0073	
8-CDF	0.0005		
8-CDD+8-CDF	0.0078		

(*) Based on 10% di O₂

3. EVALUATION OF THE PROCESS TECHNOLOGY EMPLOYED IN THE INCINERATION PLANTS

The three incineration plants installed in Lagos were designed according to different technologies. In order to obtain an adequate evaluation of the process technology, we have considered separately the two plants design, one supplied by Claudius Peter (two units) and the other one by Marini.

a) "Claudius Peters" design

It is very important to point out that the design does not take into account recent guidelines and heightened concepts for environmental quality.

This means the lack of any flue gas cleaning unit for the reduction of what we called in the previous section "air pollutants" and "solid ash residue". The multicyclones unit, installed to remove only the particulate material, is not suitable to reach the level emissions required from the present stringent regulations.

Besides, also the energy recovery unit has been provided in these facilities. This may not be necessary from the environmental point of view, but it can be very important considering the situation of power supply in Nigeria. The plant was provided with two diesel power generators (one in operation and one in stand-by) because of difficulties for the electric power supply.

The incinerator with the moving stokers is able to meet the good combustion practice maintaining the three "t"'s in the combustion zone. These are temperature, turbulence and time. The three "t"'s plus adequate oxygen ensure complete combustion.

Appreciable, from the technical point of view, is the drying unit installed in the plants.

b) Marini design

From the environmental point of view this design has similar problems as the other one. In this case, the electrostatic precipitator installed to remove the particulate material can meet the required limit of emission for this air pollutant.

Moreover, the installed composting line is not suitable for producing good quality "compost", according to the present requirements.

The incinerator with moving grate stokers was designed according to adequate engineering standard.

The waste recovery system is missing.

In conclusion, the two plant technologies could have been useful according to the past standards.

For use now, a flue gas cleaning section to remove the air pollutants, according to the environmental protection regulations should be added. Waste heat recovery must be carefully considered. However, these plants must be revamped so that the impact on environment and health risks are minimized through the use of best available technologies for controlling emissions and ash, and so that the generated heat not passed on can be used on site.

4. CURRENT STATUS OF INSTALLED PLANTS AND ESTIMATED COST
OF MAKING THE PLANTS OPERATIONAL

A) MARINI PLANT

B) CLAUDIUS PETERS - SIMPSON STREET

C) CLAUDIUS PETERS - EBUTE METTA

D) LOCATION OF SOLID WASTE DISPOSAL PLANTS IN LAGOS
(NIGERIA)

Attachment: 1) Mapping of the plants

2) Photographic survey of the plants

A) MARINI PLANT - INSPECTION REPORT

1. GENERATING SETS

- No. 4 Rolls Royce generating sets: have been completely vandalised and all vital parts were removed.
- No. 4 Siemens alternators: appear in fair condition.
- No. 4 cooling radiators/fans: badly damaged by rust and rain water infiltration.
- All accessories (heat exchangers, pumps, oil pumps and valves, diesel oil circulation system: all removed.
- Control panels: completely emptied of all parts.
- Battery set: damaged.
- Connecting cables: completely removed.
- Internal lighting system: removed.
- Roofing and shutters: badly damaged by rust,
- Housing: in good condition.

REMARKS:

Completely out of use.

2. ELECTRICAL STATION/TRASFORMER CABIN

- No. 4 HT/MT transformers: in good condition.
- No. 1 set protection boxes with switches: removed.
- No. 1 set panels with switches for the transformer parallel lines and distribution of supply lines: completely removed.
- No. 1 set of rephasing units: damaged/removed.
- Connecting cables: completely removed, including earth connections with omnibus bars.
- Internal lighting system: removed.
- Fire estinguishers: removed.
- Structure: in good condition.

REMARKS:

Only the transformers can be reutilized.

3. CONTROL CABIN

All control panels for both incinerating lines have been completely emptied, removed/vandalised/including the automatic furnace temperature controls. The remaining parts are completely out of use.

- No. 2 airconditioners and internal lighting: removed.
- Roofing: badly damaged by rust, thus causing water infiltrations into the under-roofing damaging both floor and panels.
- All connecting cables and wiring: completely removed.
- Intercom system: removed.
- Structure: in fairly good condition.
- Fire extinguishers: removed.

REMARKS:

Nothing can be re-utilized.

4. BRIDGE CRANE CONTROL ROOM

- All the control panels have been damaged and all components removed.
- No. 2 control units: removed, damaged.
- No. 2 TVCC: removed.
- No. 2 A/C: removed.
- All connecting cables/wiring: completely removed.
- Structure: in fairly good condition.
- Lighting system: removed
- Window blinds: damaged.
- Intercom system: removed.

REMARKS:

Only the starting resistances can be utilized.

5. No. 2 BRIDGE CRANES, CRAB BUCKETS AND WASTE COLLECTING PIT

- No. 12 motors: removed with the exception of the 2 lifting electrical motors.
- The motoreducers have been badly damaged.
- Hydraulic brake controls: damaged.
- Pull boxes: removed.
- Limit switches control boxes: removed.
- All connecting cables and festoon cables: removed.
- Railing: some have been removed.
- No. 2 control panels for hoist servicing: emptied.
- No. 2 pulley motors: removed.
- No. 6 limit switches for the automatic stopping device: removed, damaged.
- No. 4 TVCC: removed.
- No. 8 roll up doors: in fairly good condition.
- No. 8 ropes, limit switches and brake shoes: damaged.
- Roofing: completely damaged.
- No. 2 submerged water pumps: removed.
- No. 1 control panel: emptied.
- Structure: in good condition.

REMARKS:

The 2 bridge crane and grab buckets can be re-utilized by reconditioning and replacing hydraulic and mechanical parts.

6. OFFICES

- Office structure: appears in good conditions.
- Furniture: removed.
- Bath/changing rooms: sanitary ware removed.
- Lighting system: removed.
- No. 5 A/C: removed.
- Intercom system: removed.
- Doors, windows and blinds: damaged.
- Roofing: damaged.

REMARKS:

Can be re-utilized.

7. COMPOSTING LINE

- Apron feeders: in good conditions.
- Hatches for discharge: deformed.
- Feeding plates: partially damaged.
- No. 4 rotating cylinders: in good conditions.
- Water pumps and accessories: removed.
- No. 2 electrical motors: removed.
- No. 2 control panels: removed.
- No. 16 tyres and rims: removed.
- No. 2 ballistic separators

External parts of the ballistic separators in fairly good conditions.

- No. 2 electrical motors: one removed, one damaged.
- High speed conveyer belt: damaged.
- No. 11 conveyer belt: damaged.
- No. 10 belts: removed.
- No. 5 rollers: removed.
- No. 10 electrical motors: removed.
- Crankcases: removed.
- All belts, V-belts, cleaning brushes and accessories: to be replaced.
- No. 1 hammer-mill refiner.
- No. 1 electric motor: removed.
- No. 1 magnetic separator.
- No. 1 electric motor: removed
- Rubber belts, listels and chain: damaged.

- No. 1 control panel: badly damaged with most parts removed.
- Hydraulic press feed belt.
- No. 1 electric motor: removed.
- No. 1 optical devise: damaged.
- Cutters: rusted.
- Accessories for hydraulic station and pistons: badly damaged.
- No. 1 electric motor for metallic conveyer: removed.
- No. 1 metallic conveyer: rusted.
- No. 1 control panel composting: completely emptied.
- No. 1 press control panel: completely damaged, emptied.
- No. 2 intercom system: damaged, removed.
- All connecting cables: removed, damaged.

REMARKS:

The whole composting line can be re-utilized once it has been refurbished.

8. INCINERATING FURNACE - LINE 1/2

- Refractory lining: appears in good condition.
- Grates: in good condition.
- Revolving grates: parts to be replaced.
- No. 4 burners: in fairly good condition.
- No. 2 secondary air fans: electric motors, pulleys, V-belts with supports have been removed.
- No. 4 tertiary air fans: electric rotors, pulleys, V-belts with supports have been removed.
- No. 8 thermal couple PT RH PT with relative transducers: badly damaged, removed.
- No. 2 differential pressure devices with converts: removed.
- Structure: water infiltrator.

REMARKS:

Can be re-utilized.

9. UNDER FURNACE AREA

- The whole area is completely submerged in water therefore:
- No. 2 primary air fans: damaged.
- No. 2 hydraulic stations: removed.
- No. 6 electric motors: removed.
- No. 2 fans: removed.
- No. 2 slag drainage tanks: damaged beyond repairs.
- No. 2 electric motors: removed.
- No. 2 surge tanks: damaged beyond repairs
- All chains and pinions: to be replaced.
- No. 1 compressor and No. 2 pumps: removed.
- Control panel: emptied.
- Structure: apparently in good condition, although a static test will be required.

REMARKS:

With the continuous presence of water, all machinery and parts will have to be changed.

10. SLAG PIT

- No. 2 drainage pumps: removed.
- Control panels: removed.
- No. 1 slag pit bridge crane: damaged by rust.
- Control panel: emptied.
- Cables/wiring: removed.
- Structure: in good condition.

REMARKS:

All can be re-utilized.

11. HEAT EXCHANGERS 1 AND 2

- No. 6 electric motors, V-belts and pulleys: removed including cables/wiring.
- Connecting cables: mostly removed remaining-badley damaged.
- Railing: damaged and/or removed.
- All heat exchanging tubes: in good condition, but it is advisable to substitute them.
- Fans: in good condition.
- Support structure: rusty, but does not compromise the structural strength.
- No. 2 by-pass for heat exchanger: completely damaged.
- Temperature converters: removed.
- Refractory lining in mixing by-pass zone: damaged.
- Dampers and electric motoreducers: damaged by rust.
- Discharge hoppers: heavily obstructed by particles of rust and dust.

REMARKS:

General reconditioning and substitution of heat exchanging tubes, heat exchanger for furnace by-pass can be replaced with some technical modifications. Replacement and general reconditioning of damaged parts. Can be re-utilized.

12. HEAT EXCHANGER CLEANING UNITS

- Screen base and magnet operated valve: completely blocked by rust: screw mesh broken by rust.
- Screw conveyor: fouled and completely blocked, damaged by rust.
- Fans: to be reconditioned.
- Cleaning system by steel balls of 4 to 6 mm: all rusted and no longer existing.
- The separating and distribution of steel balls system: completely damaged by rust and refractory lining completely damaged.

REMARKS:

The only utilizable parts are the motoreducers.

13. ELECTROSTATIC PRECIPITATORS

- Framework appears in good condition.
- Steel casing: rusted, but can still be recovered.
- The No. 2 unit is in a better general condition than No. 1 unit.
- Steel wool inner lining: in good condition.
- Inspection doors and high voltage cambers: damaged by rust.
- No. 8 electric motors for shaking units: removed.
- The mobile earth connections: some damaged, removed
- All cables/wirings: removed.
- Anti-condensation device: damaged.
- Motoreducers: blocked by rust.
- Railing: to be changed or reconditioned.
- Lighting system: 3 have been removed.
- Screw conveyors: blocked, destroyed by rust.
- No. 8 electric motors for screw conveyors: removed.

REMARKS:

Both units can be salvaged by reconditioning and replacing missing parts.
No. 6 screw conveyors: to be completely changed.

14. CHIMNEY

- External structure: in fairly good condition although rust is evident.
- Refractory material in lower part of chimney: in good condition.
- Refractory material in the upper part: in very bad condition; the wire net used for anchorage of refractory material is uncovered and rusted.
- No. 2 fans: very badly damaged by rust.
- No. 2 dampers with motor reducer: damaged and blocked by rust.
- No. 2 smoke density meters with electrical devices: removed.
- Aircraft security warning lights: damaged.
- No. 8 projecting lights: removed.

REMARKS:

Can be re-utilized if fans are replaced and the refractory is reconditioned.

15. AUXILIARY SERVICES

- No. 1 fuel tank of 50.000 litres: in fairly good condition.
- No. 2 diesel motors for pumps: removed.
- No. 1 control panel: removed.
- Cables, wiring and panel: removed.
- No. 1 water tank of 40.000 litres: in fairly good condition.
- No. 2 electropumps: removed.
- No. 1 control panel: removed.
- Some hydraulic parts: removed.
- Cables, wiring: removed:
- No. 1 electropump with panel and cable: removed.
- Panel and cables: removed.

16. SELF-PROPELLED EQUIPMENT

- One tractor: to be completely overhauled.
- Two trailers: in fairly good condition.
- One loader: to be scraped; bucket can be salvaged.
- One shovel: to be scraped.

17. WORKSHOP

All tools and spares have been removed with the exception of one working bench.

18. ACCESS ROADS

- Some parts of the perimeter boarder wall: damaged.
- Entrance gates: damaged.
- Access roads around the plant: are still in fairly good condition although vegetation is rapidly covering the area due to lack of maintenance.
- Some cement electric cable coves: damaged.

19. WEIGH BRIDGE

- The control room building: in fairly good condition.
- Lighting system: damaged
- Cables: removed.
- Weigh bridge: in good condition.
- Scale and equipment: in good condition.

REMARKS: Can be re-utilized.

COST ESTIMATE FOR THE REHABILITATION OF THE PLANT

The cost of refurbishing including labour cost for the whole plant has been estimated on the basis of European standard costs as follows:-

	U.S. \$
Mechanical components	1,322,000
Motors and electrical appliances	262,000
Instrumentations and controls	287,000
Electric generating units	609,000

	TOTAL 2,480,000

GENERAL CONCLUSION

On the basis of single remarks the following conclusions can be made:

- Civil structure: generally in good condition, although a static test will be required in areas where water has been stagnat over the past years.
- Metal structure: in good condition.
- Roofing (translucid, plate ceiling) and gutters; to be completely replaced.
- Control cabin and cables: out of use or non existent.
- Electric motors and electrical devises: have been either removed or completely damaged.
- Mechanical parts: due to the lack of maintenance and the non use of plant, the vital working parts have been badly/completely damaged.

MARINI PLANT: Estimated price for refurbishing:
U.S. \$ 2,480,000

Note:

- A) The above mentioned estimated price does not include customs duty for the necessary spare parts and relevant marine freight charges.
- B) Labour cost has been calculated considering employment of 8 expatriate technicians for an overall period of 6 months in addition to skilled and unskilled local manpower.
Therefore the cost for the 8 expatriate technicians represents the percentage of 25.2 % of the total refurbishing cost.

B) CLAUDIUS PETERS I/ SIMPSON STREET - INSPECTION REPORT

1. GENERATING SETS

- No. 1 emergency generating set (power: 250 KVA Cummins ST 50): some parts have been removed (alternator, starters and battery) and damaged. Can be salvaged.
- Control panel box: removed.
- No. 2 generating sets of 1600 KVA/each Mak Siemens: many valve 4 and injectors covers: removed.
- All water, oil and diesel pumps: removed.
- Electrical junction boxes: emptied.
- No. 4 cooling fans: removed.
- Generating connecting box: damaged.
- Railing and catwalks: removed.
- No. 2 control panels and alarm set: removed.
- Connecting cables: all removed.
- Meta cable way: damaged
- Lighting system: removed.
- Fire extinguisher: removed.

REMARKS:

Generating sets can be salvaged.

2. A) POWER STATION

- No. 2 transformers 1600 KVA each: badly damaged by theft.
- High/medium voltage cables: removed.
- Battery charger: removed.
- One set of 24 Volts batteries Ni-Cd: damaged, cannot be utilized.
- Lighting system: removed.
- Catwalks and railings: some have been removed.
- Protection fence: some parts cut and removed.

B) METAL BOX HV CABIN

- No. 6 HV equipment located in metal boxes: completely removed.
- Floating floor: removed.
- A/C and fire extinguishers: removed.
- Lighting system: removed.

REMARKS:

Only the transformers can be considered for re-utilization.

3. MAIN MV PARALLEL POWER DISTRIBUTION STATION
(NEPA/GENERATING SETS)

- One set panels for suppling all the electrical equipment: completely emptied of all components/damaged.
- Floating floor: removed.
- Lighting system: removed.
- Cables/wiring: completely removed.
- Rephasing unit: removed.
- A/C: removed.
- Fire extinguisher: removed.

REMARKS:

Completely out of use.

4. STORE WORKSHOP

- Store: spares and shelving removed.
- Workshop: all tools and equipment: removed with the exception of 3 work benches.
- Lighting system: removed.
- Doors: damaged.
- Fire extinguisher: removed.

5. FUEL TANKS DEPOT

- No. 2 tanks of 60.000 Lts/each: in good condition.
- No. 4 pumps: removed.
- Set of valves, filters: removed.
- No. 2 pumps: removed.
- All connecting pipes: in good order.
- No. 2 refueling points: damaged and some parts removed.
- Fire hydrants: removed.
- Lighting system: removed.

REMARKS:

Can be re-utilized.

6. SICK BAY - W.C. - LOCKER ROOM

- All lighting system: removed.
- All sanitary ware and piping: removed/broken.
- Windows: removed.
- Double ceiling: removed.

REMARKS:

Can be re-utilized.

7. REFUSE DISCHARGING AREA

- No. 5 rolling doors: in fairly good condition.
- Motors: removed.
- No. 5 push bottoms/controls: removed/damaged.
- Lighting system: removed.
- No. 5 warning lights: removed.
- No. 5 wall lighting system: removed.
- No. 8 light poles: removed.
- All lighting: removed.
- Cables: removed/damaged.
- Fire hydrants: removed.

REMARKS:

Can be re-utilized.

8. CRANES AND CRAB BUCKETS (MOHRE CRANE)

- No. 2 bridge cranes 6.3 Tonnes/each for refuse pit: in fairly good condition, although:
- Festoon cables: removed/burnt.
- Cable trolley: damaged by fire.
- Electrical connecting boxes: vandalised.
- Limit switch box: vandalised.
- No. 4 longitudinal transferring electrical motors: removed.
- No. 4 transversal electrical motors: removed.
- No. 4 motors for lifting/opening of crab buckets: removed
- No. 4 brake motoreducer and accessories: removed.
- No. 2 TVCC: to be reconditioned/changed.
- Fire detector and operating: to be reconditioned.
- Control crane cabin complete with panels and accessories: completely vandalised.
- A/C: removed
- Internal lighting system: removed.
- Connecting cables: completely removed.
- Structure: in good condition.
- Roofing: in fairly good condition.
- Lateral communicating doors: damaged/removed.
- Vertical drainage system: to be repaired.
- No. 2 crab buckets: in fair condition.

REMARKS:

Can be re-utilized.

9. DRYING PLANT

- No. 2 dryers: in good condition.
- Lining: lower part damaged.
- Alluminium body: approx 80% removed.
- Hydraulic system: to be reconditioned.
- No. 4 cooling fans for hydraulic pistons: removed.
- No. 2 motors for conveyer belts: removed.
- No. 4 motors for screw conveyors: removed.
- Hydraulic accessories/controls: removed.
- No. 4 depression meters: removed.
- Connecting cables: all removed.
- Hydraulic station: badly damaged by vandalism and parts removed.
- Light system: removed.
- Structure: in fairly good condition.
- Catwalks and railings: many parts removed.

REMARKS:

Can be restored and re-utilized.

10. HOT AIR GENERATORS

- No. 2 hot air generators: in fairly good condition.
- No. 2 burnes: removed.
- No. 2 motors: removed.
- Steel wool lining and panels: removed/damaged.
- No. 2 depression meters: damaged.
- No. 4 temperature converters/MA: removed.
- All connecting cables: removed.

REMARKS:

Can be restored.

11. SCRUBBERS

- No. 2 scrubbers: in fairly good condition.
- No. 2 fan motors: removed.
- No. 2 electrowater pumps: removed.
- No. 1 density meter: removed.
- Various accessories from the hydraulic circuit: removed.
- All connecting cables: removed.
- Lighting system: removed.
- Lining: removed.
- External aluminium covering: removed.

REMARKS:

Can be restored and re-utilized.

12. INCINERATING FURNACES

- No. 2 incinerating furnaces: in good condition.
- No. 8 burners: removed.
- No. 4 motors from secondary airfans and transmission: removed.
- No. 2 TVCC: removed.
- No. 2 fan motors for aircooling fumes with transmission: removed.
- No. 2 fan motors for primary air with transmission: removed.
- No. 2 depression meters: removed.
- No. 4 screw conveyor motors: removed.
- No. 1 electrowater pump: removed.
- Connecting cables: removed.
- Hydraulic station: badly damaged.
- Diesel oil circuit: mostly removed.
- Refractory lining: although it rains inside, it is in fairly good condition.
- Internal structure: in good condition.
- Catwalks and railing: most catwalks have been removed.
- External aluminium covering: removed.
- Lighting system: removed.

REMARKS:

Can be restored and re-utilized.

13. HEAT EXCHANGER

- No. 2 heat exchangers: in good condition.
- No. 16 cooling fan silencers: damaged by rust.
- No. 16 axial cooling fans: in good condition.
- Heat exchanging tubes: in good condition.
- Structure: in good condition.
- Lighting system: removed.
- Lining: damaged.
- External aluminium covering: 30% removed.

REMARKS:

Can be re-utilized.

14. HEAT EXCHANGER CLEANING UNITS

- No. 2 cleaning units: partially damaged by rust.
- No. 2 cleaning fans: removed.
- No. 2 vibrating screens: damaged by rust.
- No. 1 metal ball collecting hopper: damaged by rust.
- No. 2 distribution system in heat exchanger: in fairly good condition.
- No. 2 chain conveyors for recovered fines.
- No. 1 motor: removed.
- No. 2 units: damaged by rust.
- Connecting cables: removed.
- Lighting system: removed.

REMARKS:

Can be partially re-utilized.

15. MULTI-CYCLONS AND CHIMNEY

- No. 2 multicyclons: in fairly good condition, although rust is present inside.
- Steel wool lining: damaged.
- External aluminium covering: mostly removed.
- Lighting system: removed.
- No. 2 chimney stacks: in good condition.

REMARKS:

Can be restored and re-utilized.

16. ASHES AND IRON SEPARATORS

- No. 2 tanks: in good condition.
- No. 2 water level indicators: damaged.
- No. 2 vibrating screens: in good condition.
- No. 2 metal reject conveyor: apparently in good condition.
- No. 2 motor and transmission: removed.
- No. 2 rubber conveyors: removed.
- Steel covering: rusted/removed.
- No. 2 ash conveyors: in good condition.
- No. 2 motor and transmission: removed.
- No. 2 rubber belts: removed.
- All connecting cables: removed.
- Lighting system: removed.

REMARKS:

Can be salvaged.

17. METAL PRESS

- No. 1 metal press for recovered iron: damaged.
- No. 2 hydraulic meters: removed.
- Accessories for hydraulic circuit: removed.
- Control panel: removed.
- Power panel: emptied.

REMARKS:

Can be salvaged.

18. CONTROL CABIN

- All power panels: completely emptied.
- Floating floor: completely damaged.
- Set of control panels for measuring and monitoring: completely removed/damaged.
- No. 4 A/C: removed.
- Fire extinguishers: removed.
- Connecting cables: completely removed.
- Lighting system: removed.

REMARKS:

To be completely refurbished as only the structure can be re-utilized.

19. WATER TANKS

- No. 1 water tank: in good condition, all external covering removed.
- No. 4 electropumps: removed.
- Hydraulic accessories: removed.
- Connecting cables: removed.
- Lighting system: removed.

REMARKS:

Can be re-utilized.

20. WEIGH BRIDGE

- Weigh bridge house completely stripped of covering and windows.
- Scale and accessories: completely vandalised.
- Lighting system: removed.

REMARKS:

The weigh bridge can be re-utilized if refurbished.

21. ACCESS ROADS/FENCING

- Most fencing non existent.
- Access roads: in good condition, although some maintenance works required.
- External access road connecting the plant non existent. Very important aspect if the plant is to be re-utilized.

**COST ESTIMATE FOR THE REHABILITATION OF THE PLANT
CLAUDIUS PETER SIMPSON STREET**

The cost of refurbishing including labour cost for the whole plant has been estimated on basis of European standard costs as follows:-

	U.S. \$
Mechanical components	1,017,000
Motors and electrical appliances	322,000
Instrumentations and controls	215,000
Electric generating units	98,000

TOTAL	1,652,000

GENERAL CONCLUSION

Lack of maintenance, the non-utilization, vandalism and rust caused great damages to the plant.

- Civil structure: in good condition.
- Roofing/covering/drainage: in good condition, although some vertical drainage pipes have been removed.
- Approx 50% of the aluminium covering: has been removed thus damaging the steel wool lining.

In order to have the plant in working conditions, urgent substantial maintenance, replacement of all electrical parts and cables and replacement of all stolen mechanical parts are needed.

CLAUDIUS PETERS (SIMPSON ST.): Estimated price for refurbishing:

U.S. \$ 1,652,000

Note:

- A) The above mentioned estimated price does not include custom duty for the necessary spare parts and relevant marine freight charges.
- B) Labour cost has been calculated considering employment of 8 expatriate technicians for an overall period of 6 months in addition to skilled and unskilled local manpower. Therefore the cost for the n. 8 expatriate technicians has been estimated as 37.8 % of the total refurbishing cost.

C) CLAUDIUS PETERS No. 2 / EBUTE METTA - INSPECTION REPORT

1. A) POWER STATION

- No. 2 transformers 1600 KVA/each: in good condition.
- Medium voltage cables: removed.
- Battery charger: removed.
- Batteries (NI-CD): damaged, cannot be utilized again.
- Lighting system: removed.
- Catwalks and railings: damaged.
- Protection fence: some have been cut and removed.
- High voltage box: emptied.

B) METAL BOX HV CABIN

- No. 6 HV equipment: mostly removed and remaining damaged.
- Floating floor: mostly removed.
- A/C and fire extinguisher: removed.
- Lighting system: removed.

REMARKS:

Only the transformers could be considered in working condition once overhauled.

2. GENERATING SETS

- No. 1 emergency generating set (power 250 KVA Cummins ST 250): some parts have been removed (alternator, starter and battery); can be re-utilized once overhauled.
- Control box: removed.
- No. 2 generating sets (1600 KVA/each - Mak/Siemens): some valve and injectors covers: removed.
- All water, oil and diesel pumps: removed.
- Electrical junction boxes: removed.
- No. 4 cooling fans: removed.
- Generating connection box: in fair condition.
- No. 2 control panels and alarm sets: damaged.
- Railing and catwalkes: few removed.
- Connecting cables: removed.
- Lighting system: removed.
- Fire extinguisher: removed.

REMARKS:

Can be re-utilized.

3. MAIN MV PARALLEL DISTRIBUTION STATION (NEPA/GEN. SETS)

- One set panels for suppling all the electrical equipment: completely emptied of all components/damaged.
- Flooting floor: removed, damaged.
- Cables, wiring: removed.
- Rephasing unit: removed.
- A/C: removed.
- Fire extinguisher: removed

REMARKS:

Nothing can be salvaged.

4. STORE/WORKSHOP

- Store: spares and some shelving removed.
- Workshop: all tools and equipment removed with the exception of 3 working benches.
- Lighting system: damaged.
- Fire extinguisher: removed.
- Doors: damaged.

5. FUEL TANK DEPOT

- No. 2 tanks of 60.000 litres each: in good condition.
- No. 4 pumps: removed.
- No. 2 pumps: removed
- Fire hydrants: removed.
- Lighting system: removed.

REMARKS:

Can be reconditioned, repaired.

6. SICKBAY, W.C., LOCKER ROOM

- All lighting system: removed, damaged.
- All sanitary ware: removed.
- Windows: damaged, removed.

REMARKS:

Can be salvaged.

7. REFUSE DISCHARGE AREA

- No. 5 rolling doors: appear in fairly good condition.
- Electric motors: removed.
- No. 5 push bottom/controls: removed, damaged.
- No. 5 warning lights: removed.
- No. 5 wall lighting system: removed
- Cables: removed, damaged.
- No. 10 light poles with relative lighting: all lighting system removed.
- Fire hydrants: removed.

REMARKS:

Can be re-utilized.

8. CRANES AND CRAB BUCKETS - MOHRE CRANE

- No. 2 bridge cranes of 6.3 ton each for refuse pit: in good condition.
- Limit switch box: damaged.
- No. 4 longitudinal transferring motor: removed.
- No. 2 transversal motors: removed.
- No. 2 motoreducers: removed.
- No. 2 TVC: removed.
- Fire detector and operating: to be reconditioned.
- Control crane cabin: completely vandalised.
- A/C: removed.
- Internal lighting system: removed.
- Connecting cables: some have been removed.
- Structure: in good condition.
- Roofing: in good condition.
- Internal communicating doors: damaged.
- No. 2 crab buckets: in good condition.

REMARKS:

Can be salvaged.

9. DRYING PLANT

- No. 2 dryers: in good condition.
- No. 4 cooling fans for hydraulic pistons: removed.
- No. 2 motors for conveyor belts: removed.
- Connecting cables: removed, damaged.
- No. 2 hydraulic station: badly damaged by vandalism and stolen parts.
- Structure: in fairly good condition.
- Lighting system: removed.

REMARKS:

Can be restored.

10. HOT AIR GENERATORS

- No. 2 hot air generators: in good condition.
- Connecting cables: removed, damaged.

REMARKS:

Can be restored.

11. SCRUBBERS

- No. 2 scrubbers: in fairly good condition.
- No. 2 fan motors: removed.
- No. 2 electro water pumps: removed.
- Various accessories from hydraulic circuit: removed.
- Connecting cables: removed, damaged.

REMARKS:

Rusty but can be restored.

12. INCINERATING FURNACES

- No. 2 incinerating furnaces: in good condition.
- No. 4 motors from secondary air fans and transmission: removed.
- No. 2 fan motors for air cooling fumes with transmission: removed.
- No. 2 fan motors for primary air with transmission: removed.
- No. 4 screw conveyor motors: removed.
- No. 2 electropumps: removed.
- Connecting cables: partially removed, damaged.
- Hydraulic station: completely emptied.
- Structure: in good condition.
- Lighting system: removed, damaged.

REMARKS:

Can be restored.

13. HEAT EXCHANGES

- No. 2 heat exchanges: in good condition.
- No. 16 cooling fan silences: rusted.
- Structure: in good condition.
- Connecting cables: removed.
- Lighting system: removed, damaged.

REMARKS:

Can be salvaged.

14. HEAT EXCHANGES CLEANING UNIT

- No. 2 cleaning units: in good condition.
- No. 2 cleaning fans: removed.
- No. 2 chain conveyors for recovered fines: apparently in good condition.
- No. 2 motoreducers: removed.
- Connecting cables: removed, damaged.

REMARKS:

Can be salvaged.

15. MULTI CYCLONS & CHIMNEY - STACKS

- No. 2 chimney-stacks: in good condition.
- Connecting cables: damaged, removed.
- Lighting system: damaged.

REMARKS:

Can be salvaged.

16. ASHES AND IRON SEPARATORS

- No. 2 vibrating screens: in good condition.
- No. 2 metal reject conveyors: in good condition.
- No. 2 motors and transmission: removed.
- No. 2 rubber conveyors: removed.
- Steel covering: rusted.
- No. 2 ash conveyors: in good condition.
- All connecting cables: removed.
- Lighting system: removed.

REMARKS:

Can be salvaged.

17. METAL PRESS

- No. 1 metal press for recovered iron: damaged.
- No. 2 hydraulic motors: removed.
- Accessories for hydraulic circuit: some removed.
- Control panel: damaged.
- Power panel: emptied.
- Hydraulic cylinder: removed.
- Lighting system: removed.

REMARKS:

Can be salvaged.

18. CONTROL PANEL

- All power panels: completely emptied.
- Flooting floor: removed, damaged.
- Set of control panels for measuring, monitoring: damaged, removed most vital instruments.
- No. 4 A/C's: removed.
- Fire extinguisher: removed.
- Connecting cables/wire: removed.
- Lighting system: removed.

REMARKS:

To be completely refurbished.

19. WATER TANK

- No. 1 water tank: in good condition.
- No. 4 electropumps: removed.
- Hydraulic accessories: removed.
- Connecting cables: removed.
- Lighting system: removed.

REMARKS:

Can be restored.

20. WEIGH BRIDGE

- No. 1 control unit: damaged
- Weigh bridge pit: full of water.
- Lighting system internal/external: removed.
- Windows: removed.

REMARKS:

Can be re-utilized.

21. ACCESS ROADS

- Most of the fencing: non existent.
- Gates: damaged.
- Paved area: in good condition.
- Access road to the plant: could be better located.

**COST ESTIMATE FOR THE REHABILITATION OF THE PLANT
CLAUDIUS PETER IN EBUTE METTA**

The cost of refurbishing including labour cost for the whole plant has been estimated on the basis of European standard cost as follows:-

	U.S. \$
Mechanical components	791,000
Motors and electrical appliances	317,000
Instrumentation and controls	193,000
Electric generating units	90,000

TOTAL	1,391,000

GENERAL CONCLUSION

The plant seems as though it has never functioned. Nevertheless it has suffered due to lack of maintenance and vandalism, but less damaged compared to other plants.

The inspection carried out concluded as follows:

- Civil structure: in good condition.
- Metallic structure: in fairly good condition.
- Roofing and coverings: in good condition.
- Panels containing electrical equipment (both HV/MV distribution: have been completely removed.
- The control cabins have been completely emptied of all electrical parts and equipment.
- Electrical motors: some have been removed, but it is presumed that the remaining will also, sooner or later, be removed.
- Connecting cables: partially damaged or removed.
- Instrumentation equipment controlling, temperature, pressure and fumes: have been removed or badly damaged.

CLAUDIUS PETERS (EB): Estimated price for refurbishing:
U.S. \$ 1,391,000

Note:

- A) The above mentioned estimated price does not include customs duty for the necessary spare parts and relevant marine freight charges.
- B) Labour cost has been calculated considering employment of 8 expatriate technicians for an overall period of 6 months in addition to skilled and unskilled local manpower.
Therefore the cost for the 8 expatriate technicians has been estimated as 44.9 % of the total refurbishing cost.

D) LOCATION OF SOLID WASTE DISPOSAL PLANTS IN LAGOS (NIGERIA)

In view of the possibility of the eventual rehabilitation of the three incinerating plants for the disposal of solid waste their location and environmental consequences have to be analysed.

A) MARINI PLANT

The plant is located off the OSHODI - ISOLO express road, in a metropolitan industrial area. Unlike the Claudius Peter plants, it is located in an area of low population density.

The incinerating plant (two TRUMMER furnaces having 300 M.T. daily capacity) is equipped with "FLACK" electrostatic filter able to avoid atmospheric pollution. Incineration of solid waste with high calorific value coming from the selection of the composting plant will assure healthy and clear environment.

Operation of the composting line (4 Vickers cylinders having a daily capacity of 600 M.T.) can generate adverse environmental consequences but which can be easily avoided by extending the composts stock area or by transferring selected raw material to be refined in a nearby area.

B) CLAUDIUS PETER PLANT EBUTE METTA AREA

The plant is located in the midst of densely populated area.

It is important to note that at this plant solid wastes are not preselected and due to their low calorific value predrying process is needed before incineration.

The multi-cyclone centrifugal deduster does not guarantee the necessary protection against environmental pollution.

C) CLAUDIUS PETERS PLANT SIMPSON AREA

The plant has been located next to a public school and very near a market.

Like the similar plant at Ebute Metta, solid wastes are not preselected and due to their low calorific value a predrying process is required before incineration. The multi cyclone deduster system does not guarantee the necessary protection against environmental pollution.

PHOTOGRAPHS RELATIVE TO
CLAUDIUS PETERS - EBUTE METTA



VIEW OF MAIN ACCESS ROAD TO
THE PLANT

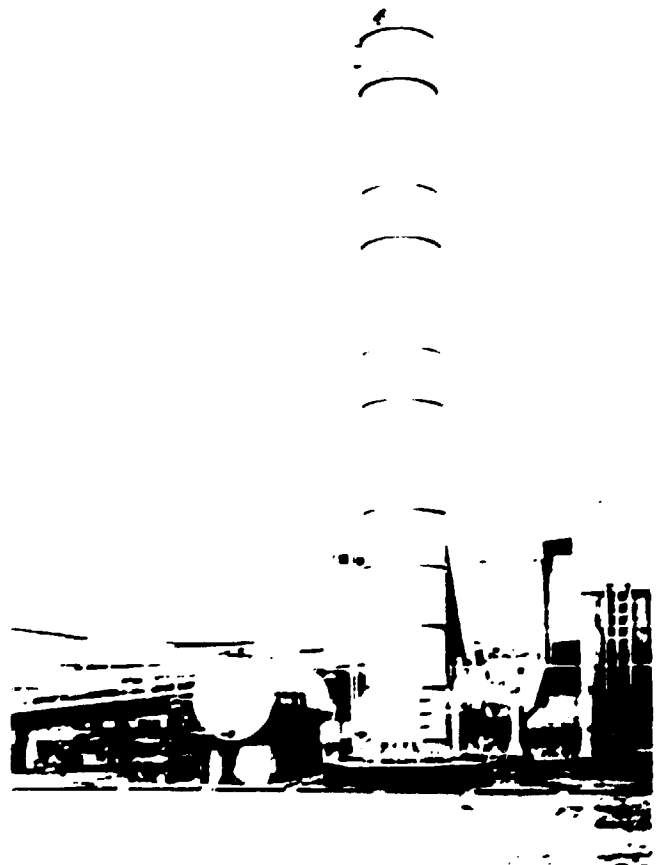

VIEW OF CHIMNEY/WATER DEPOT

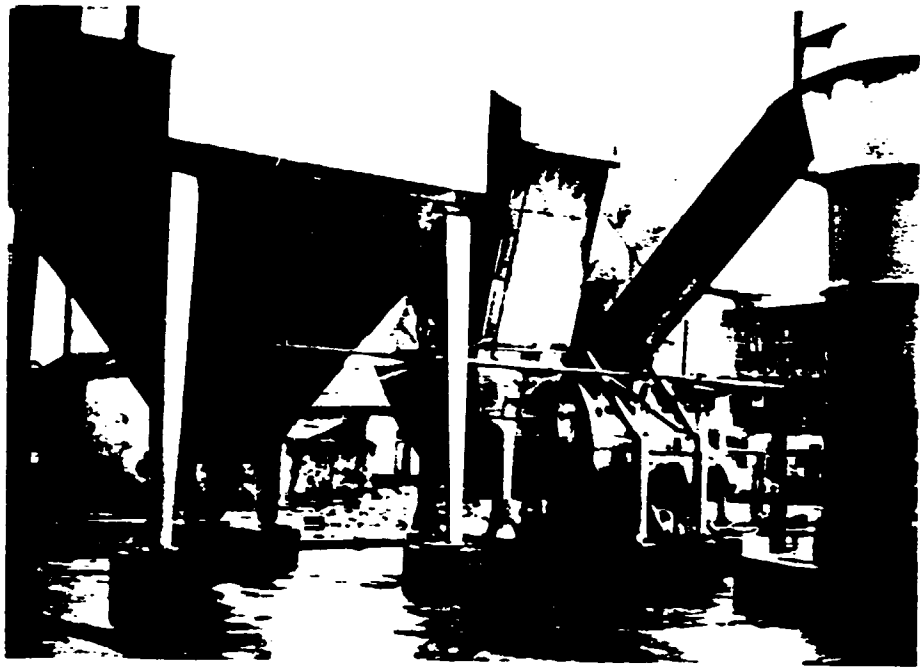

MULTI CYCLONE AND BASE OF CHIMNEY



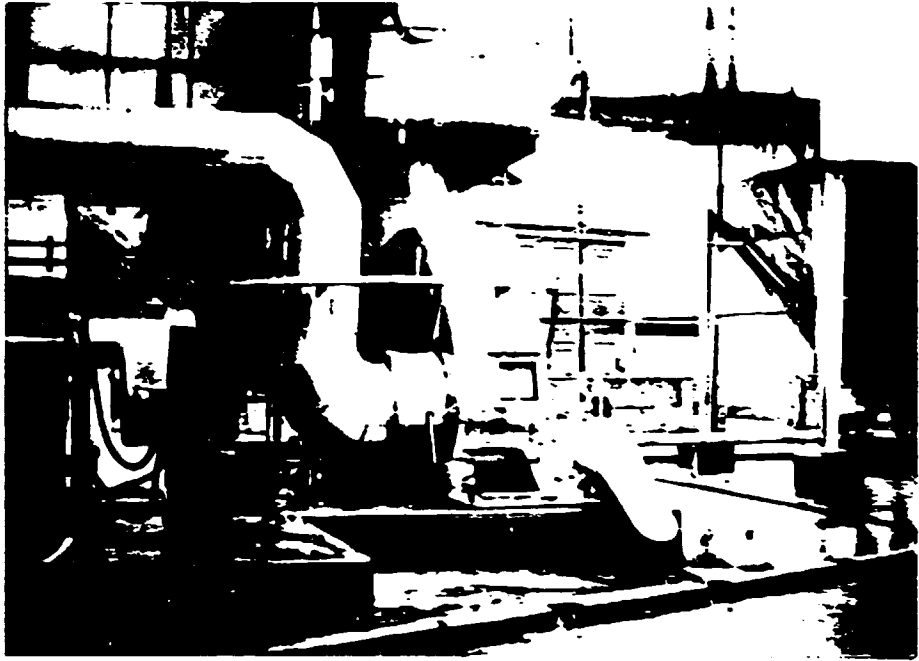

VIEW OF HEAT GENERATOR
AND SCRUBBER





VIEW OF SCRUBBER ACCESSORIES
(MISSING)

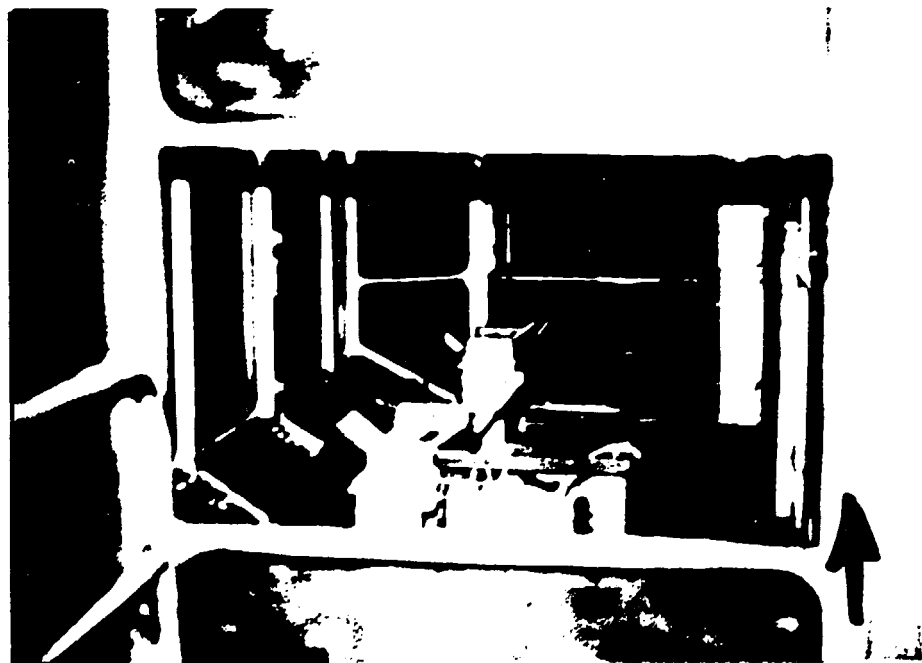

CRANE POSITION TO VIEW OF ...

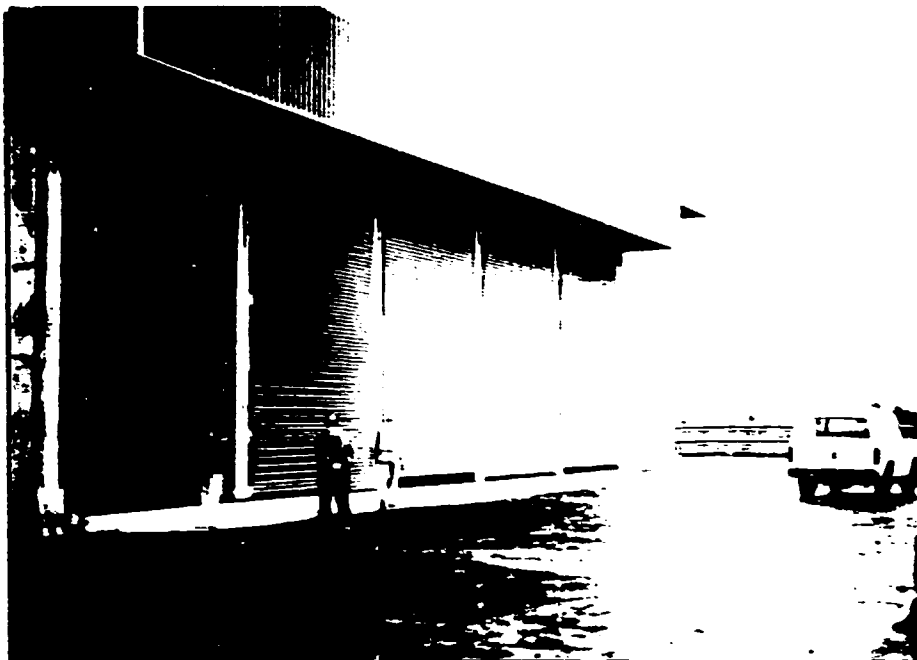

VIEW OF ROLL-UP DOORS



ROLL-UP DOORS
DOORS

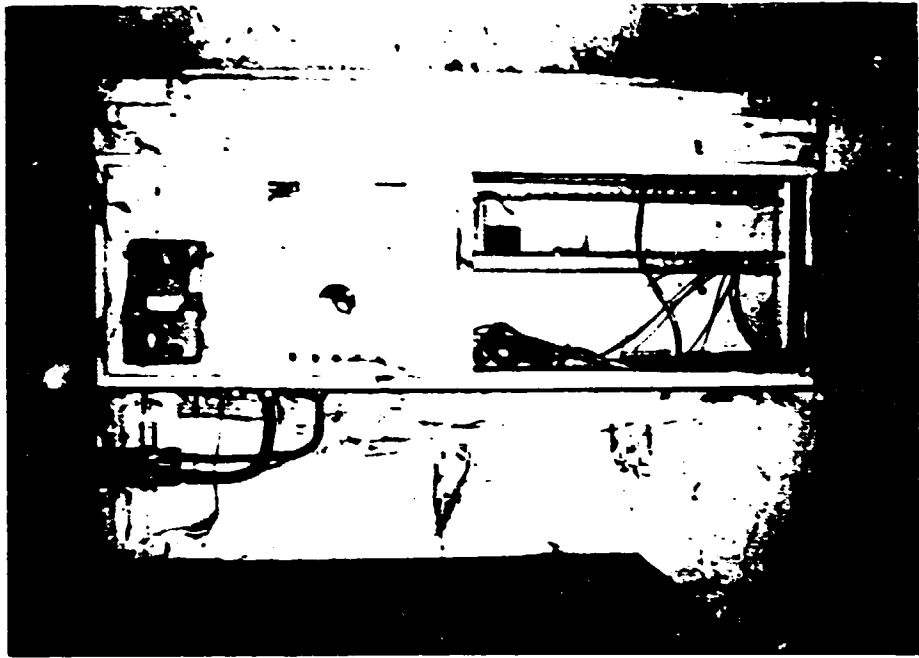

VIEW OF WORKSHOP PANEL

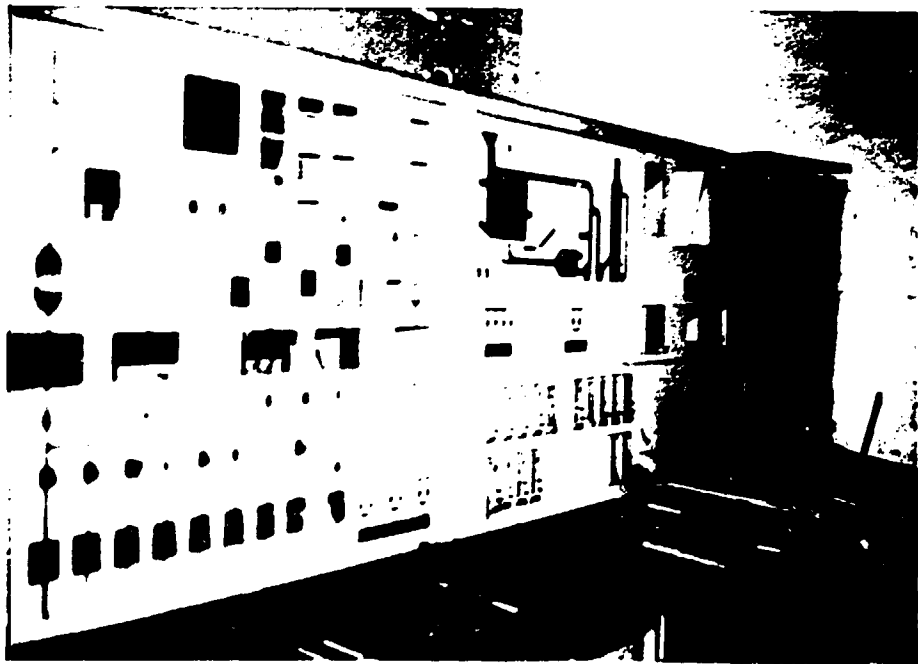

CONTROL ROOM MAIN PANEL

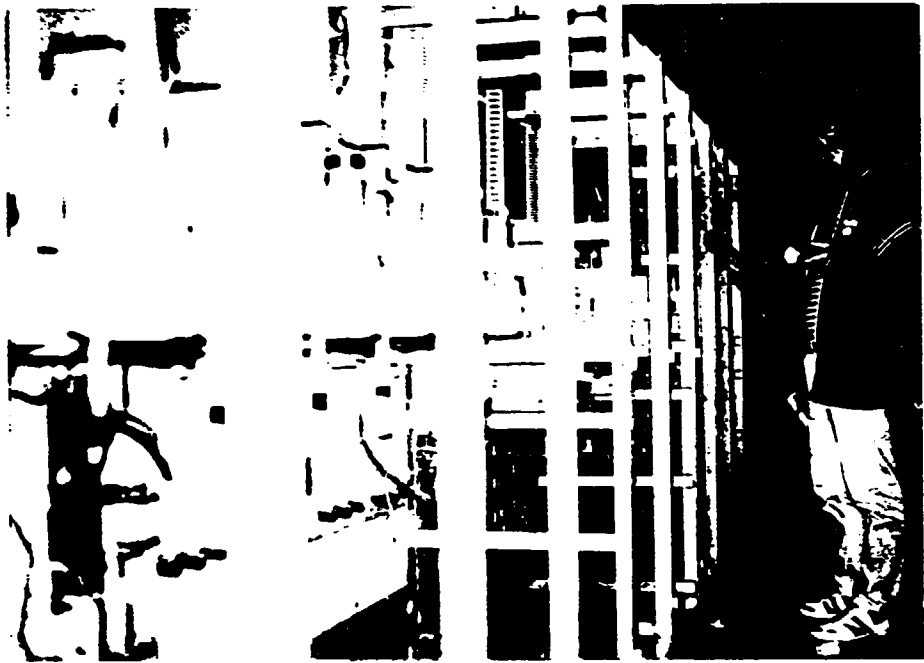

MAIN PANEL DISTRIBUTION

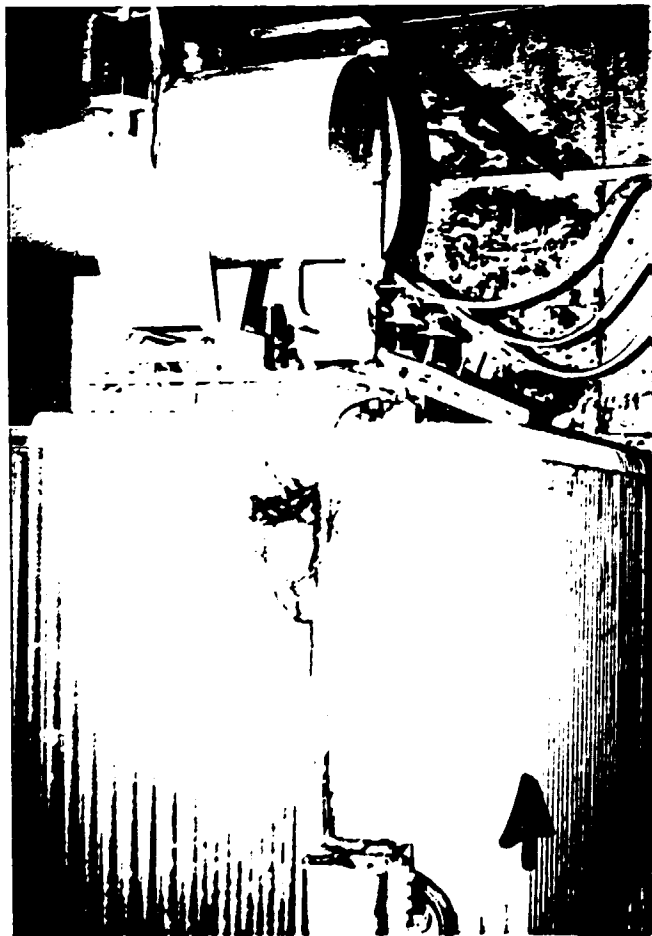

HV-MV TRANSFORMER

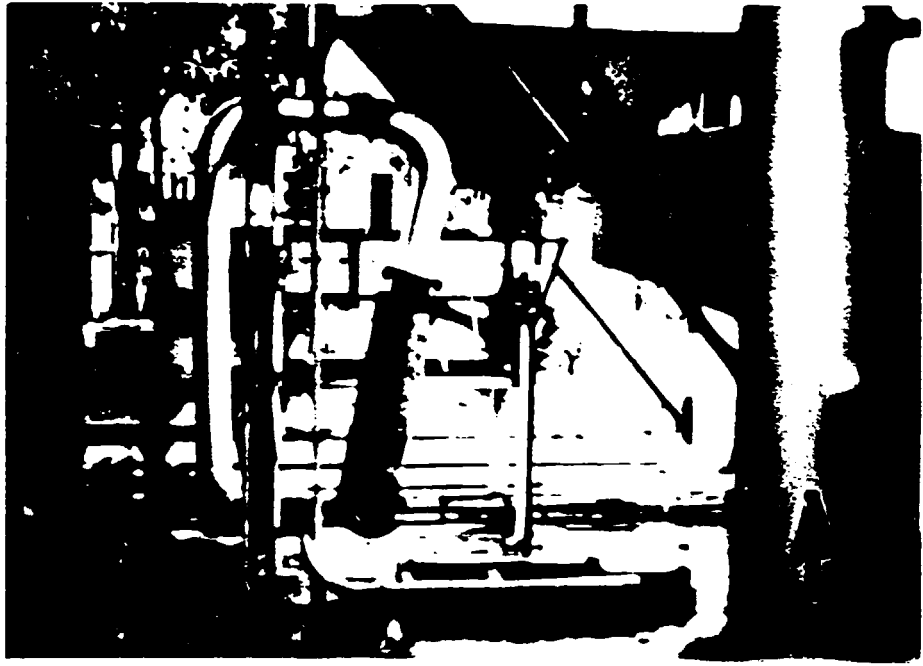

MISSING MOTOR



"HUBB" CLEANING UP



VIEW OF ASH CONVEYOR BELT

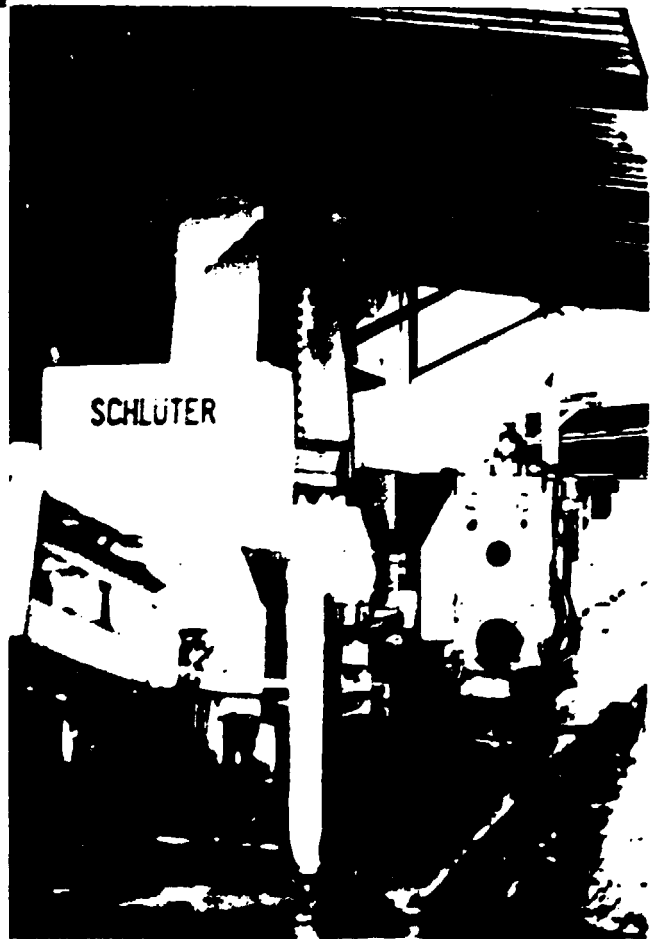

METAL REJECT 11-75



METAL REJECT PRESS

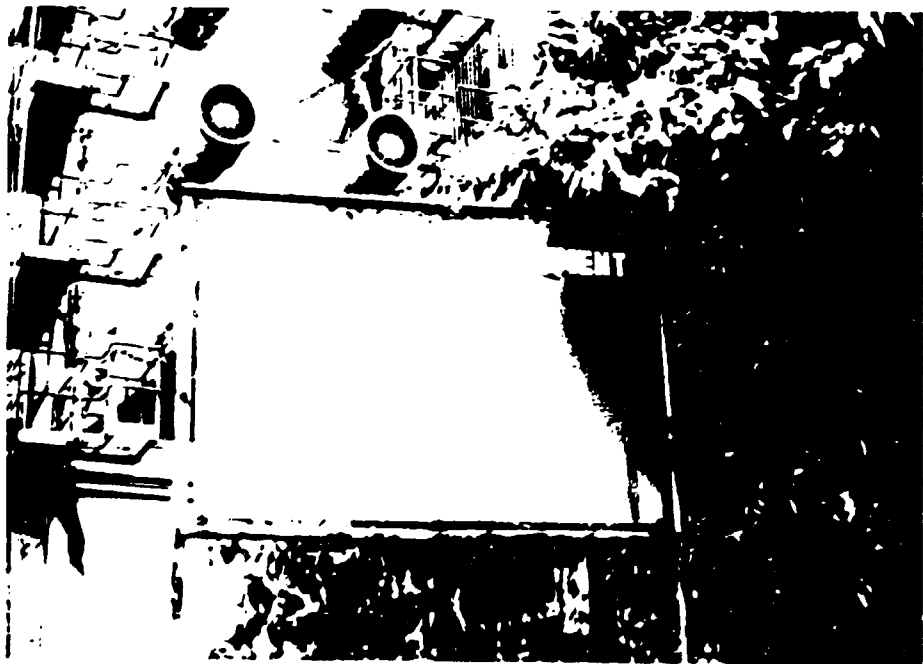

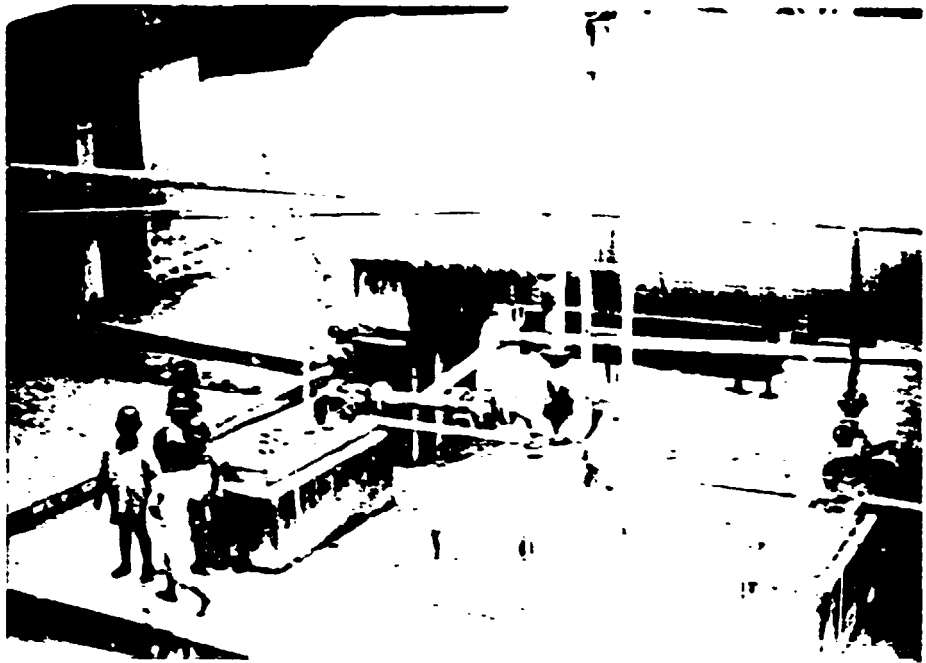

VIEW OF WATER TANK AND ACCESSORIES (REMOVED)



OUTLET ASH CONVEYER SYSTEM

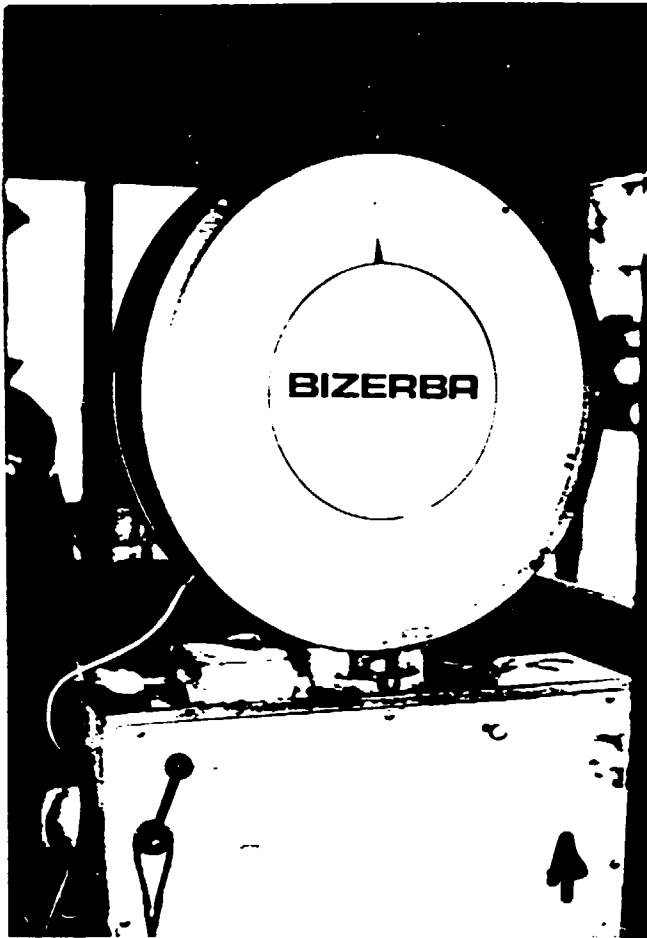

WEIGH BRIDGE - DETAILS



WEIGH BRIDGE - GENERAL



DAMAGE CABLES

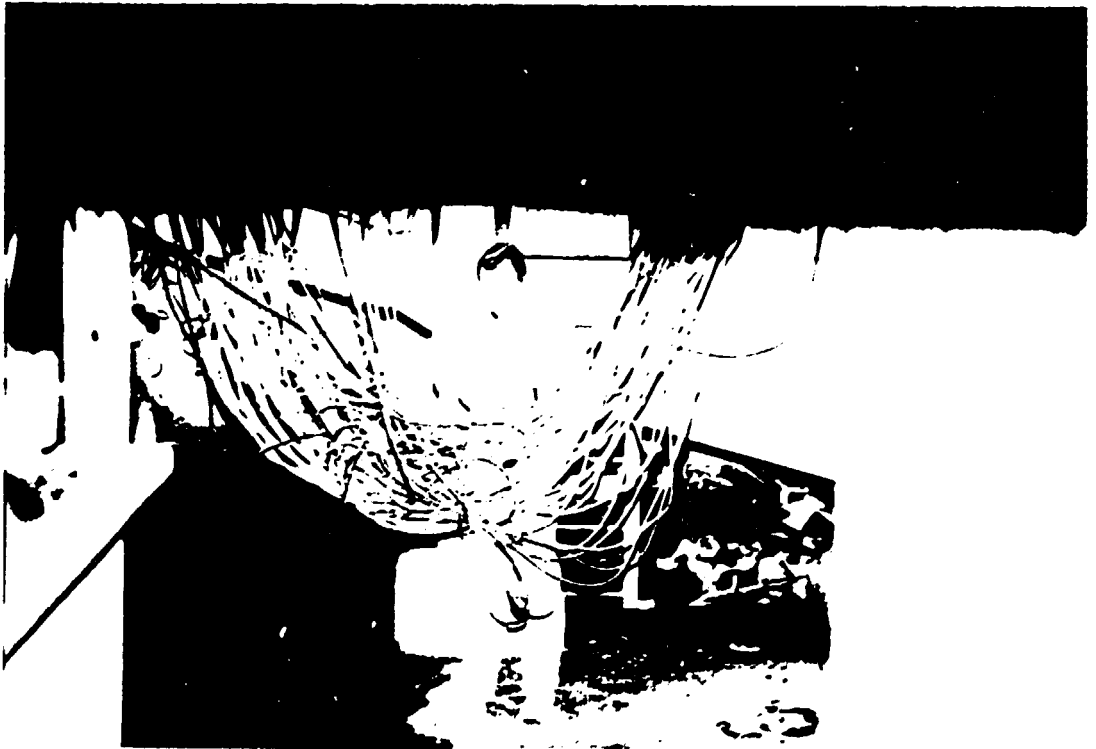

SIDE VIEW OF PERSON IN THE
HAMMOCK WITH DAMAGE

PHOTOGRAPHS RELATIVE TO
CLAUDIUS PETERS - SIMPSON STREET

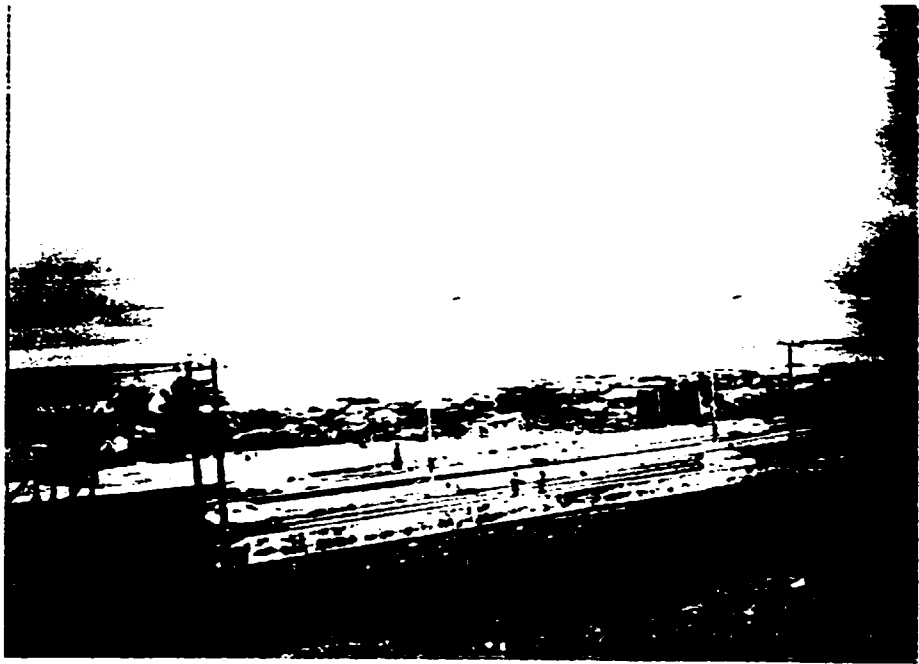

MAIN ROAD TO WHICH THE PLANT
SHOULD BE CONNECTED



VIEW FROM THE PLANT SITE
LOOKING DOWN THE ROAD



VIEW OF CHIMNEY STACK



GENERATING UNIT



VIEW OF METAL PRESS



VIEW OF WEIGH BRIDGE



FUEL PUMPS WITHOUT ACCESSORIES

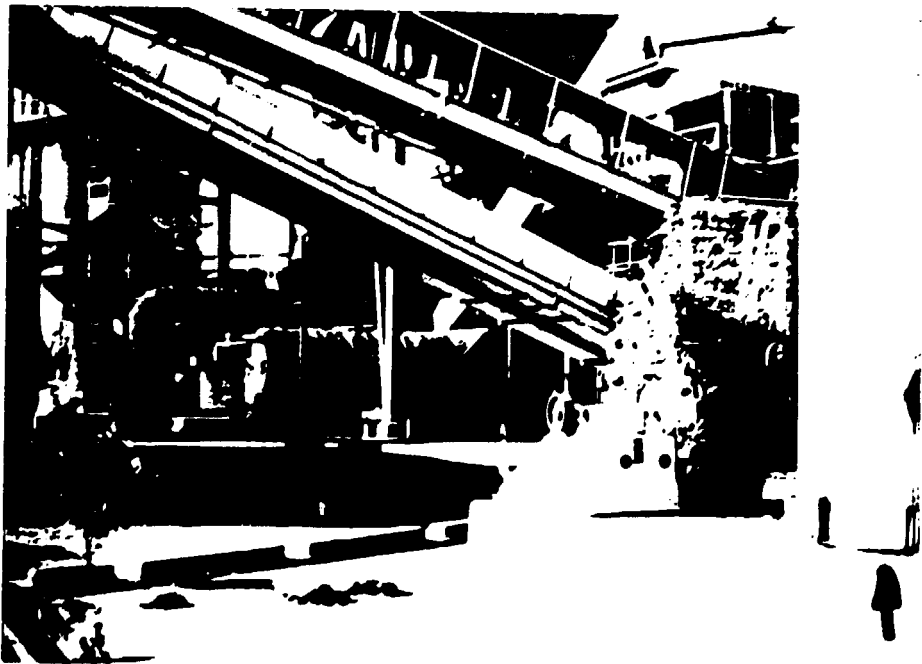

CONCRETE PIPING SYSTEM

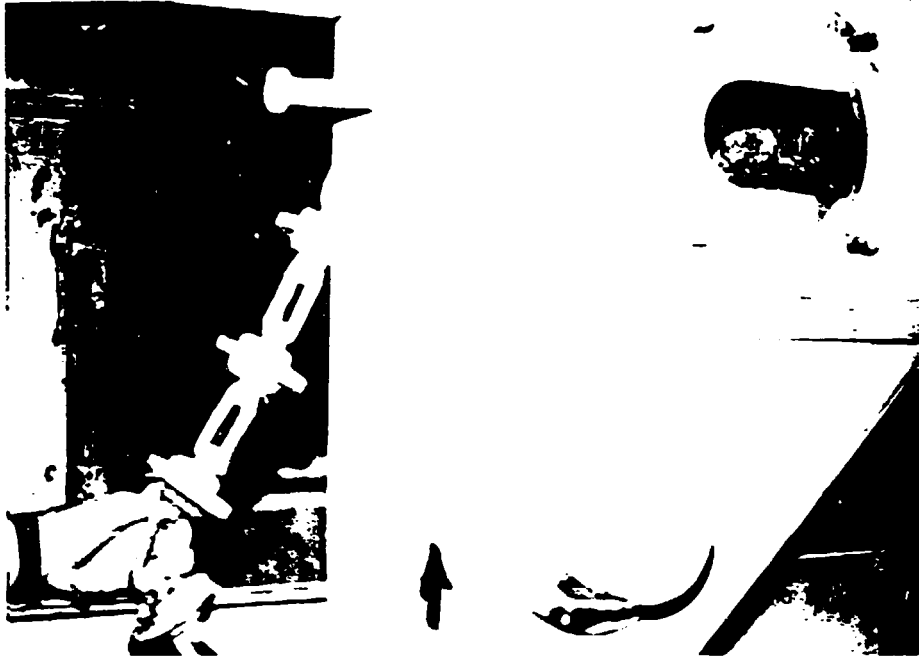

VIEW OF FINES RECOVERY
MAIN MOTOR (MISSING)





INTERNAL VIEW OF DRYER

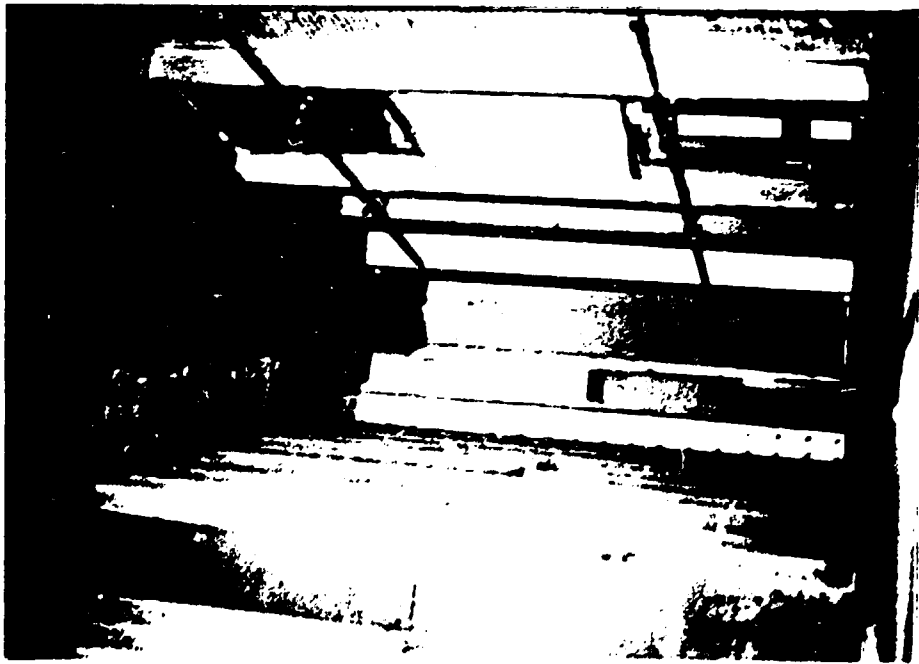

INTERNAL VIEW OF DRYER



CONTROL CABIN

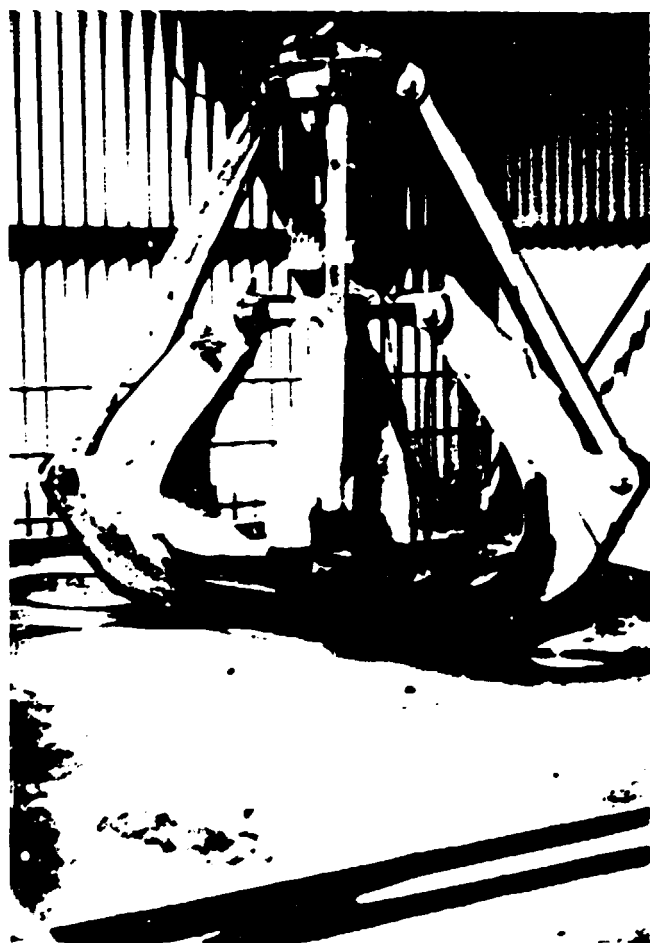

LOADER

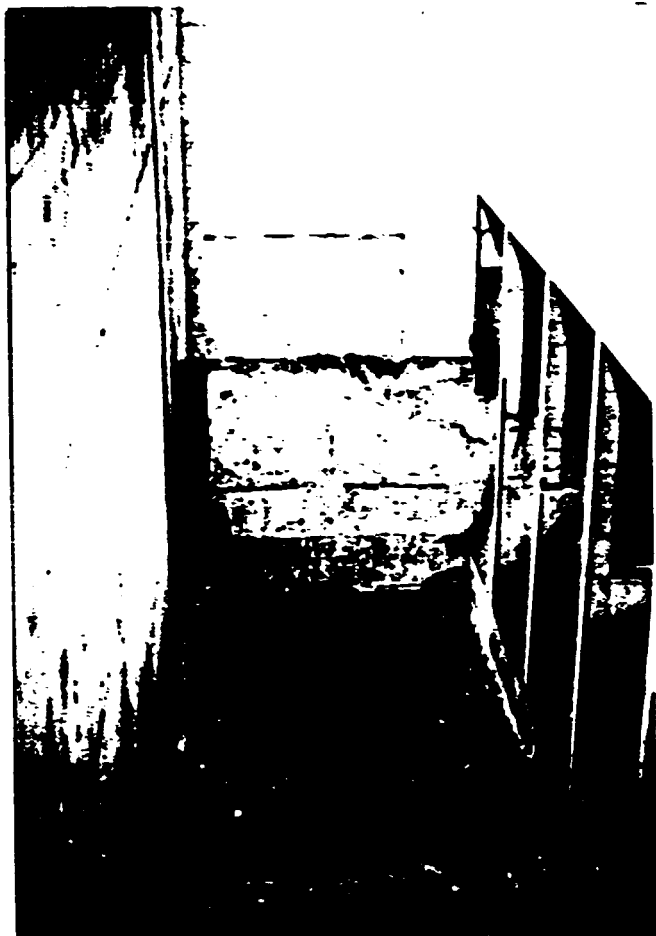

REFUSE PIT



REFUSE PIT



ROLL-UP DOORS

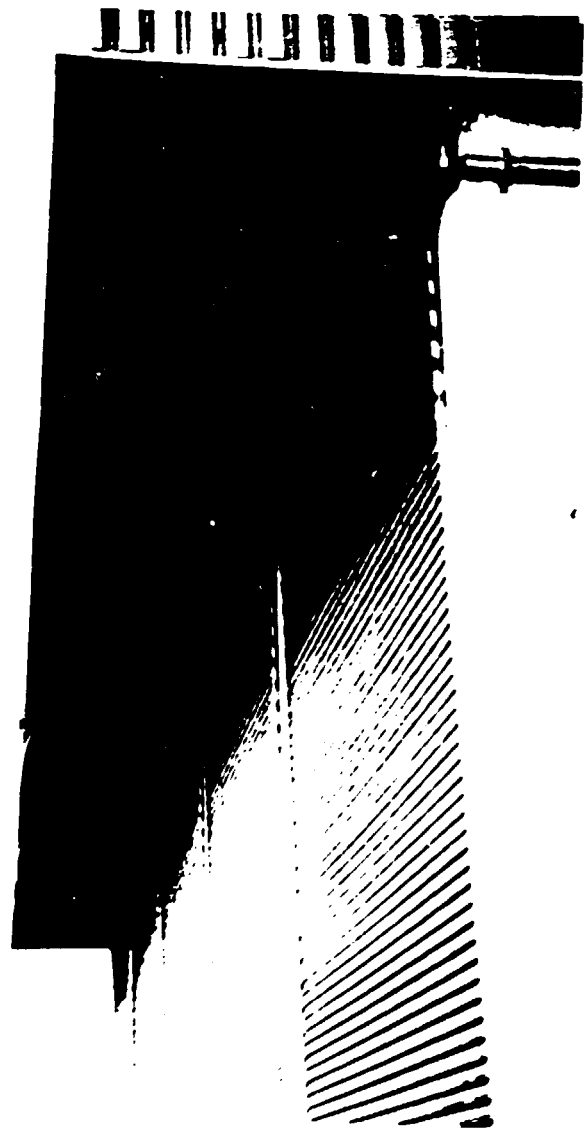



POWER DISTRIEUTION PANEL LINE 2

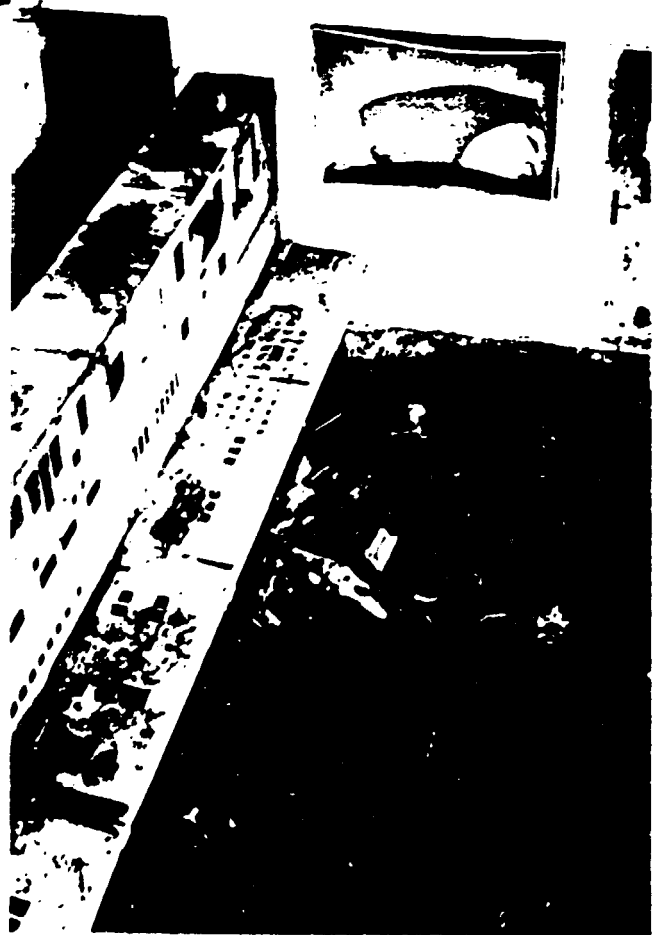

MAIN CONTROL ROOM



DRYING UNIT



PAPER COOLING FAN

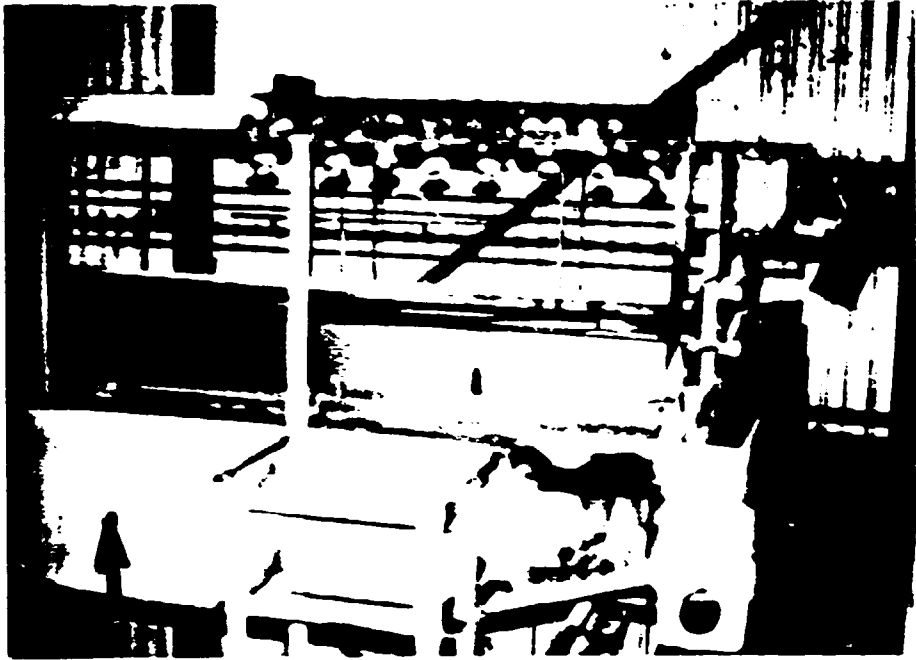

BRIDGE CRANE



CONVEYOR



VIEW OF ASH CONVEYOR
WITHOUT COVERING



ELECTROVALVE SETS FOR THE GRILL
MOVEMENT OF MATERIAL TO FURNACE



FURNACE INTERNAL VIEW

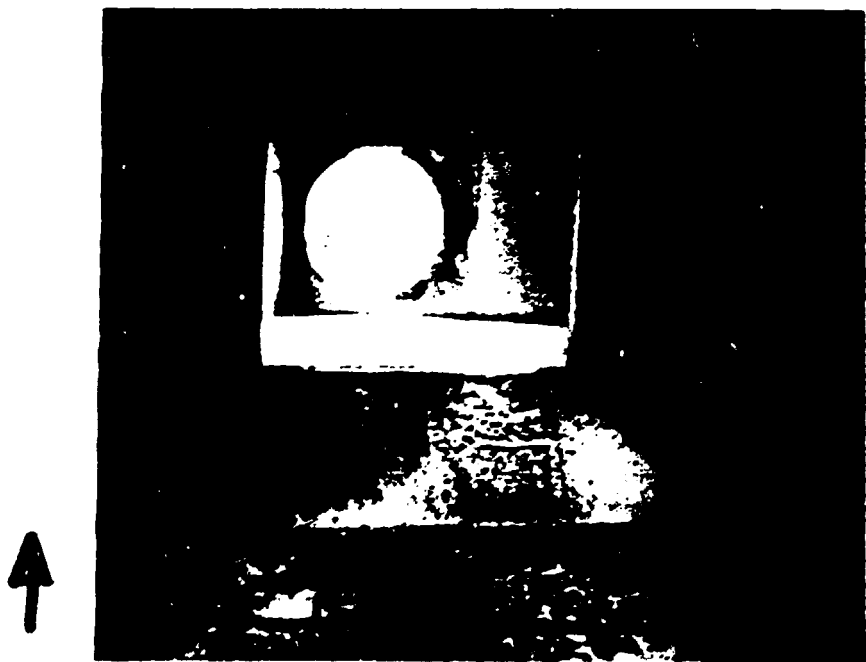

FIGURE 1. FURNACE INTERNAL VIEW
FURNACE INTERNAL VIEW



MAIN CONTROL CABIN



MAIN CONTROL BUILDING



HV CUBICLE



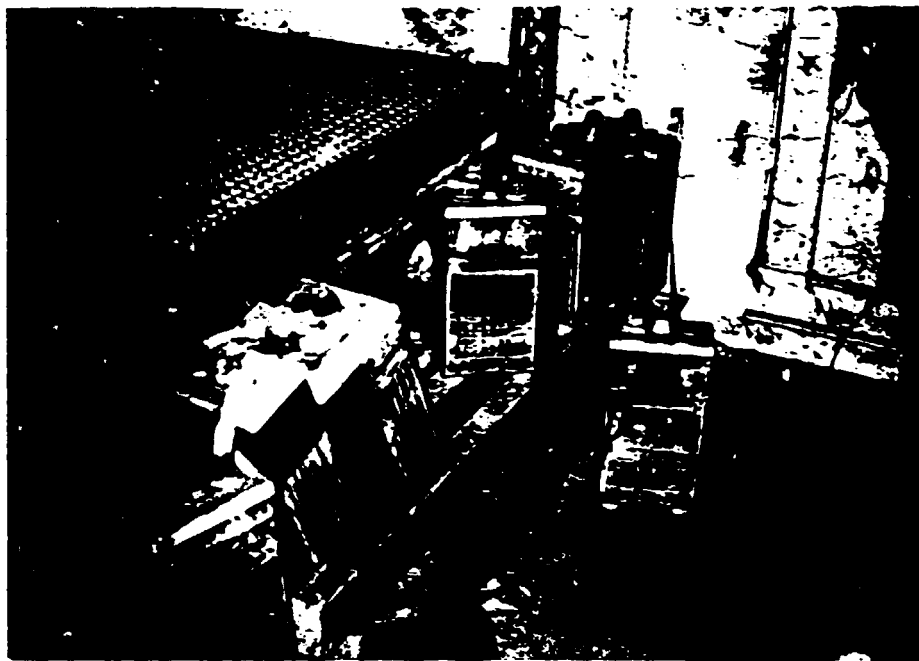

NI-CD BATTERY SET



CHARGE CHARGE CHARGE



GENERATING SETS

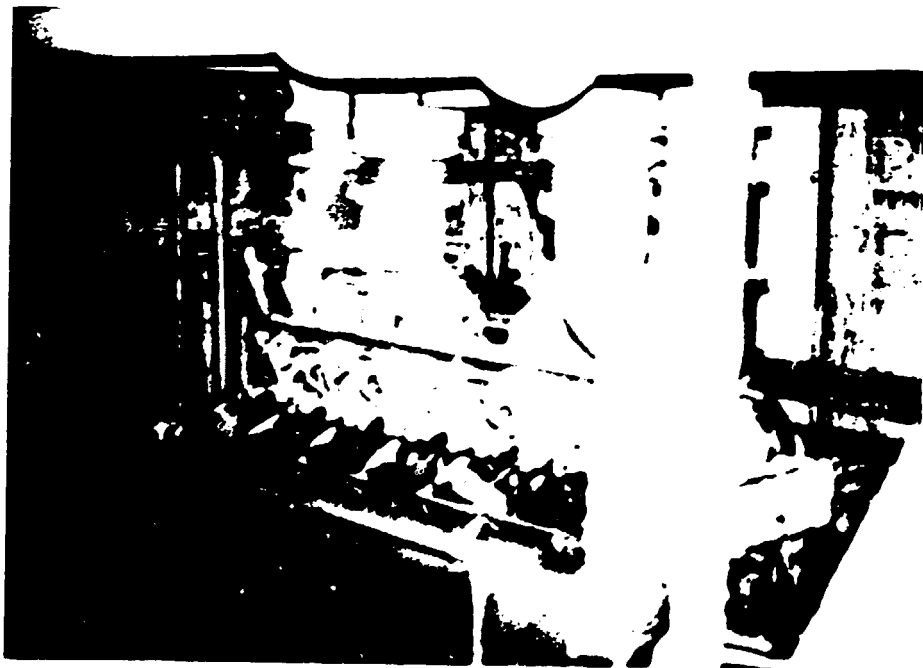

GENERATING SETS



VIEW OF STARTING (EMERGENCY)
GENERATING SETS





VIEW OF HEAT GENERATOR
(NOTE: REMOVED ALUMINIUM COVERING)



VIEW OF HEAT GENERATOR

PHOTOGRAPHS RELATIVE TO
MARINI PLANT

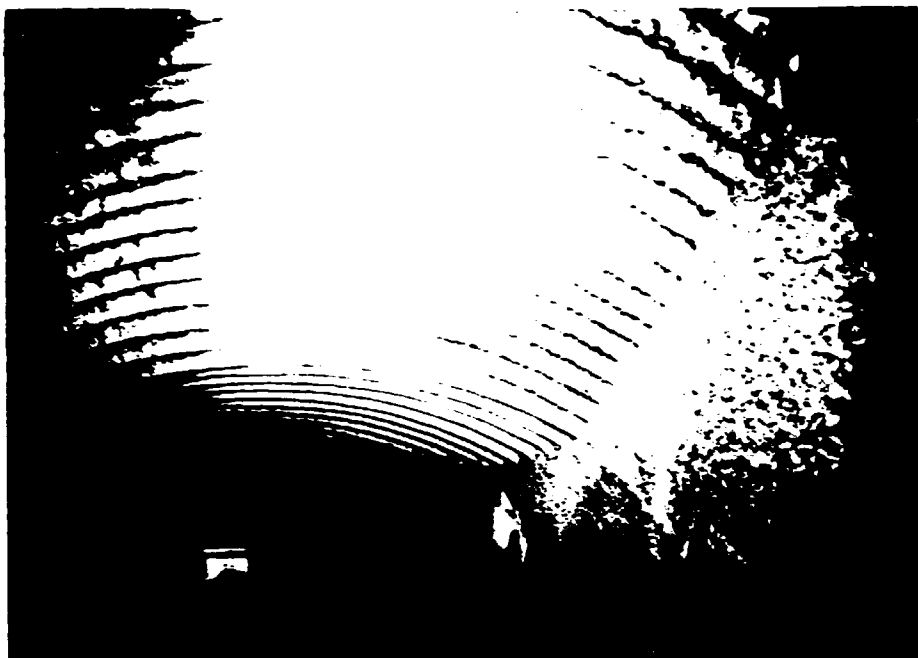

FURNACE FEEDING DOOR

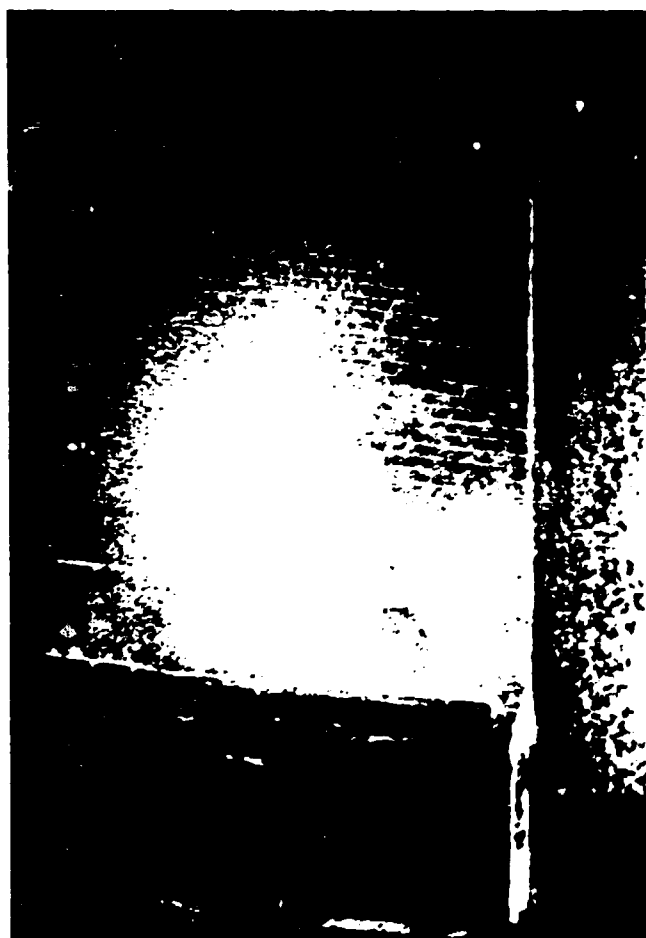

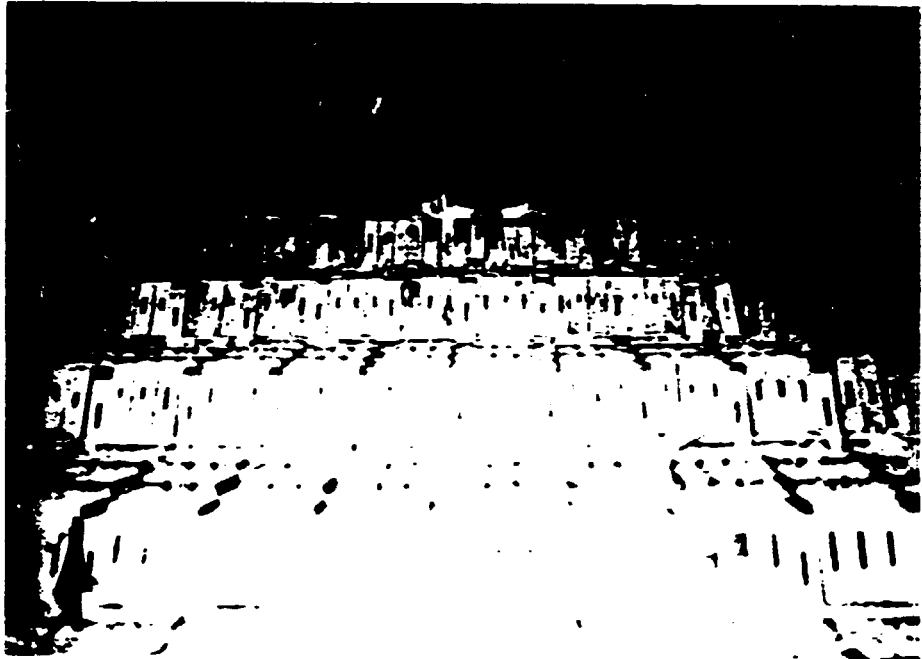

INTERNAL VIEW OF FURNACE WITH
GRATES



INTERNAL VIEW OF FURNACE WITH
GRATES



INTERNAL VIEW OF FURNACE POST
COMBUSTION CHAMBER

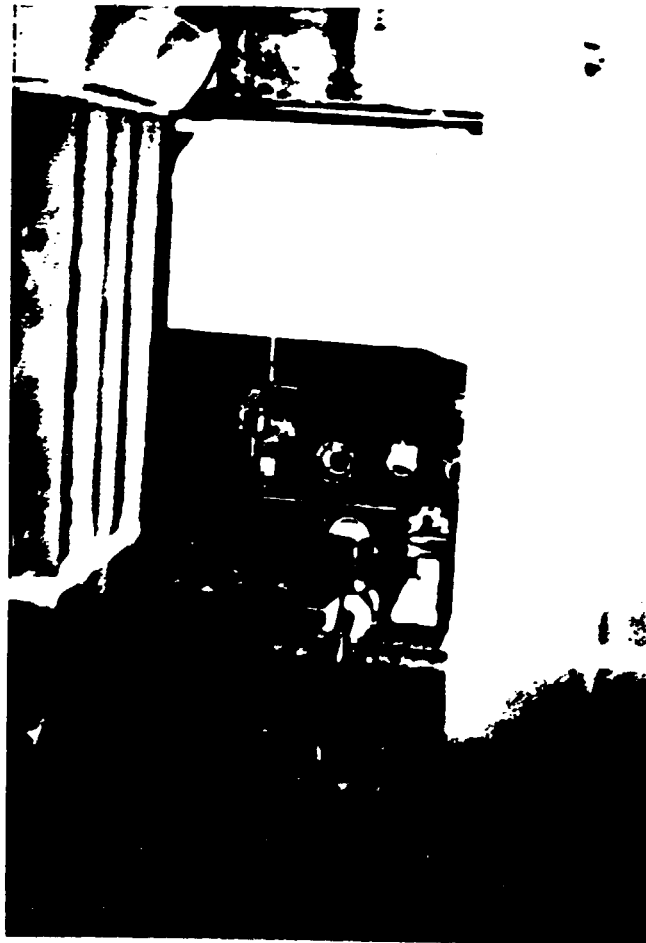

WIDE FURNACE AREA VIEW OF
HYDROCARBON SYSTEM AND HEAT EXCHANGER



FURNACE OUT-LET DUCTS

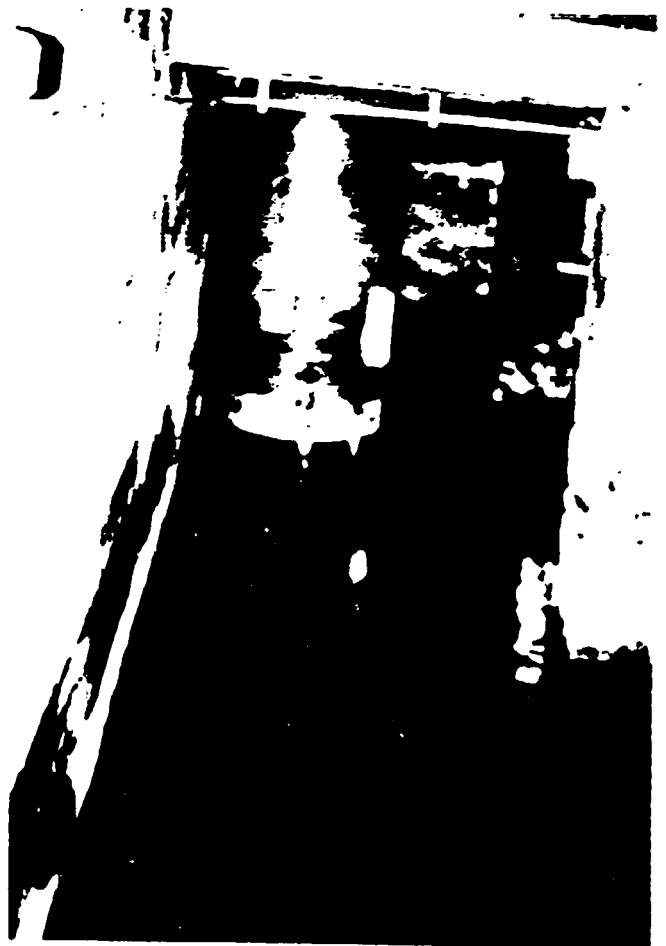

UNDER FURNACE AREA
PRESSURE TANK

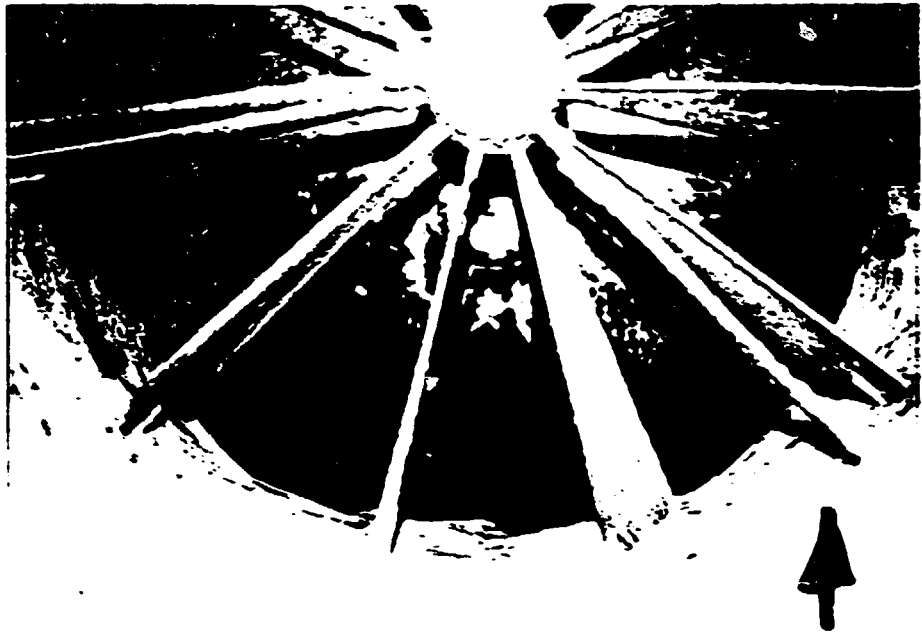

CHIMNEY FAN DUMPER



CONVEYOR SYSTEM



CHEMNEY FAN (INTERNAL VIEW)



SECTION OF CHEMNEY FAN
SHOWING LAYERED STRUCTURE

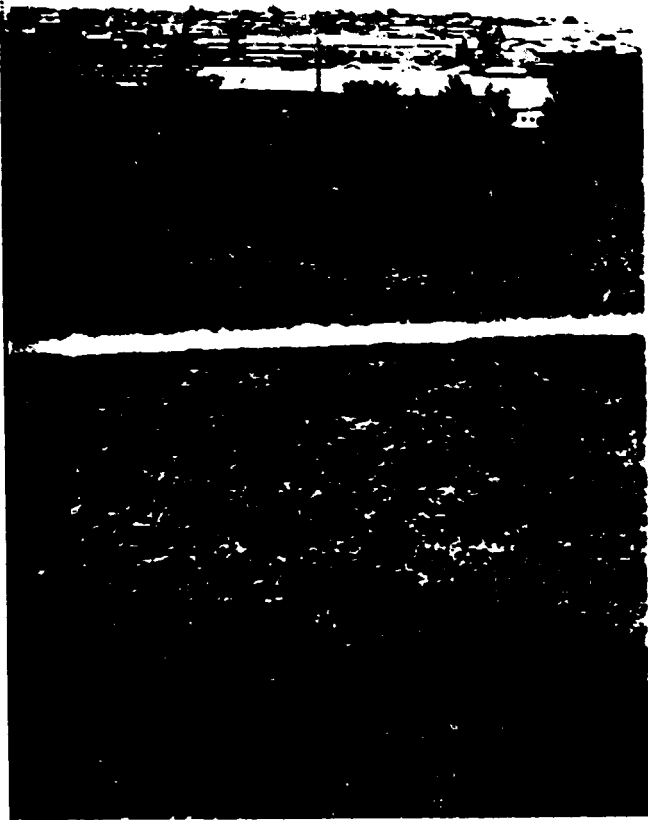

VIEW OF COMPOST AREA

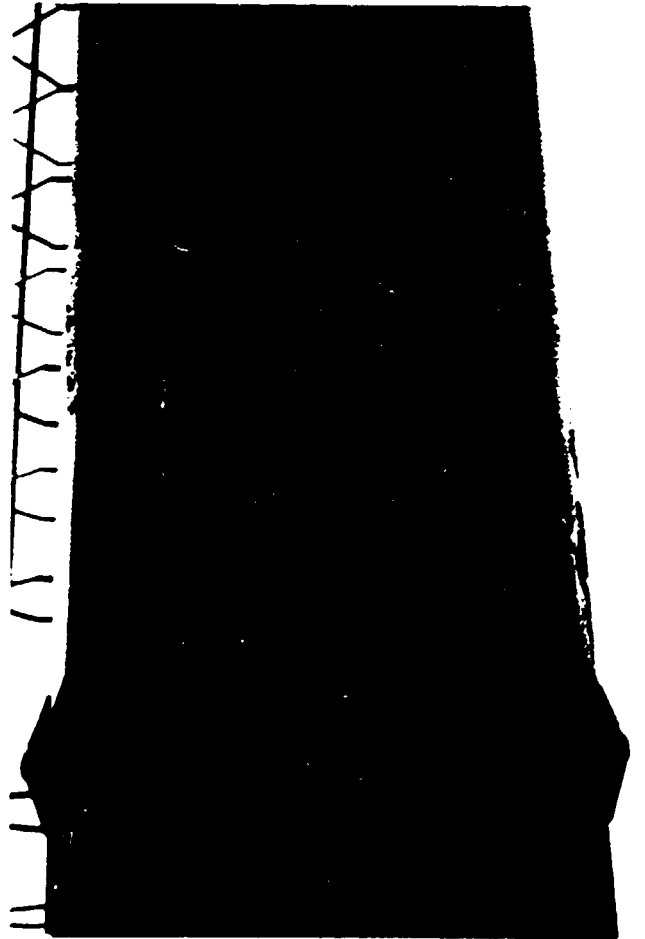



ELECTRIC STATION

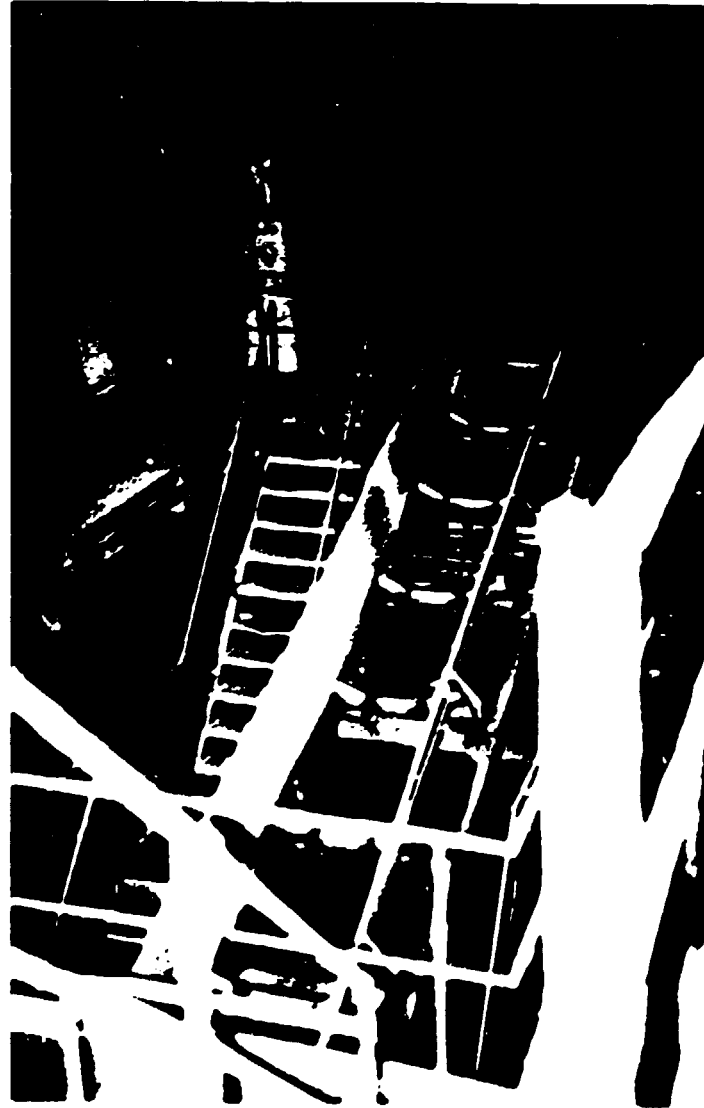



ELECTROSTATIC PRECIPITATORS
GENERAL VIEW OF RUSTED RAILING
AND CONDITION OF SAME

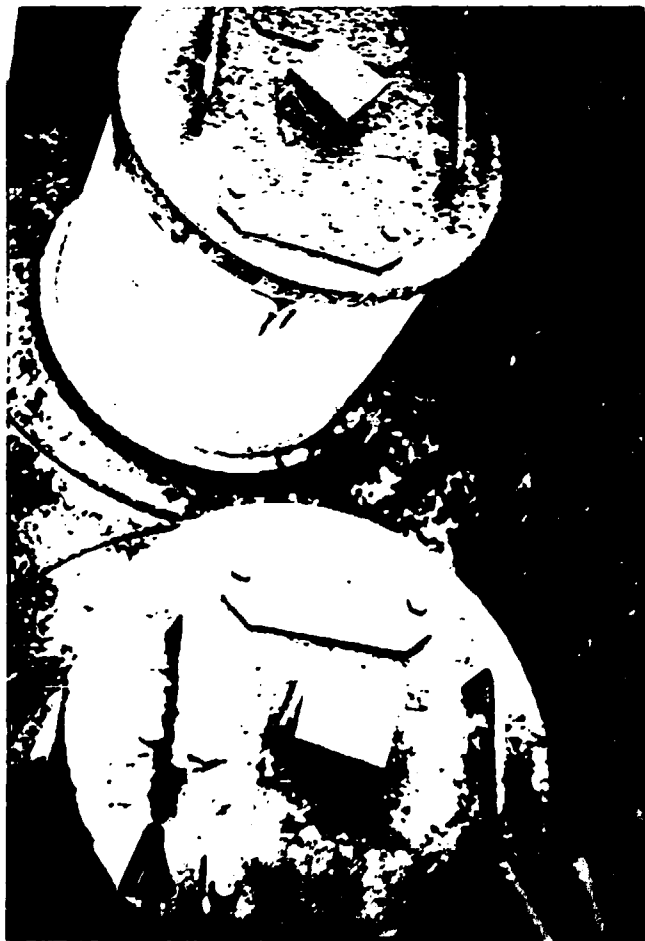

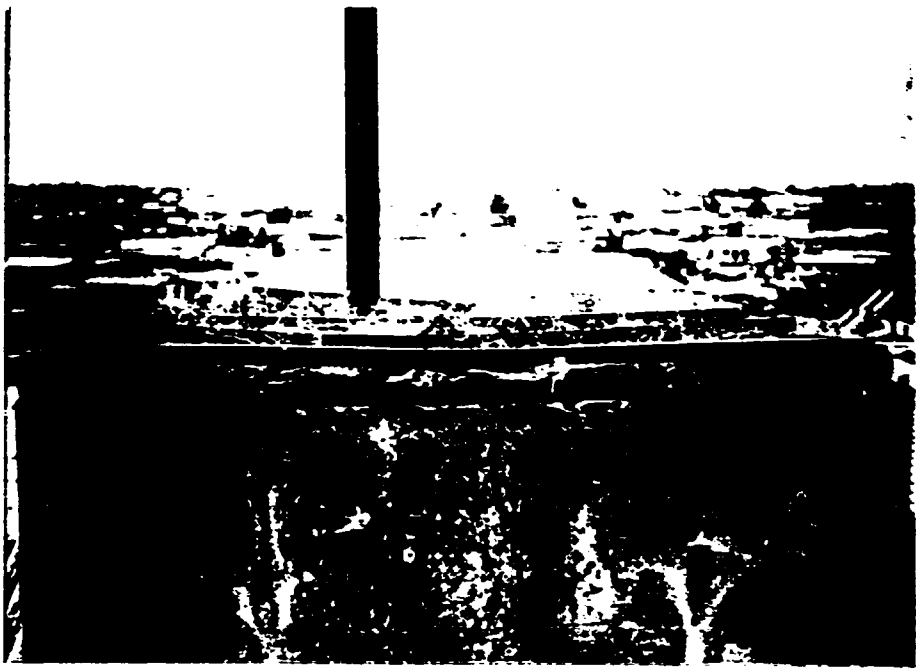

HEAT EXCHANGER BY-PASS DEVICE

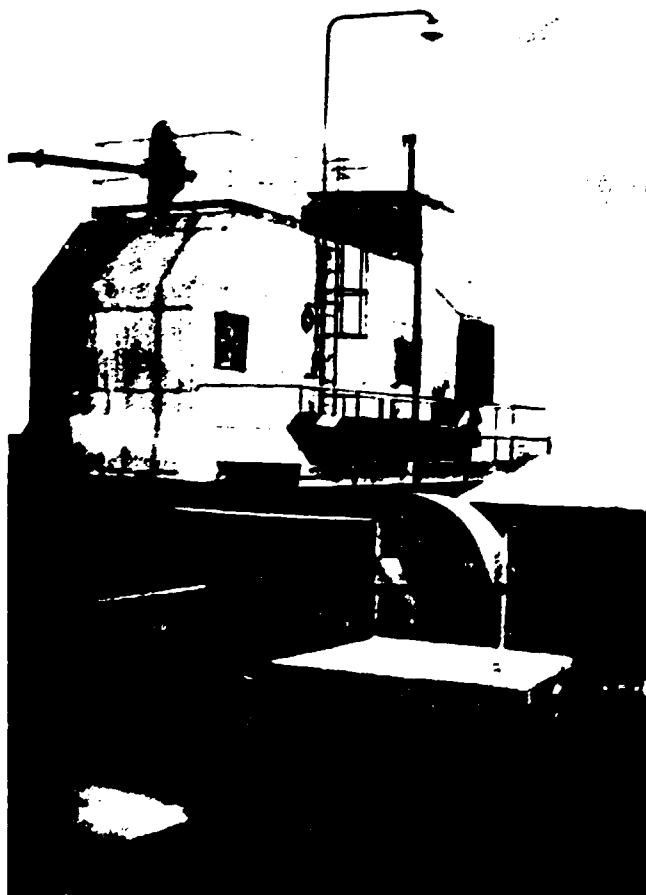

HEAT EXCHANGER BY-PASS DEVICE

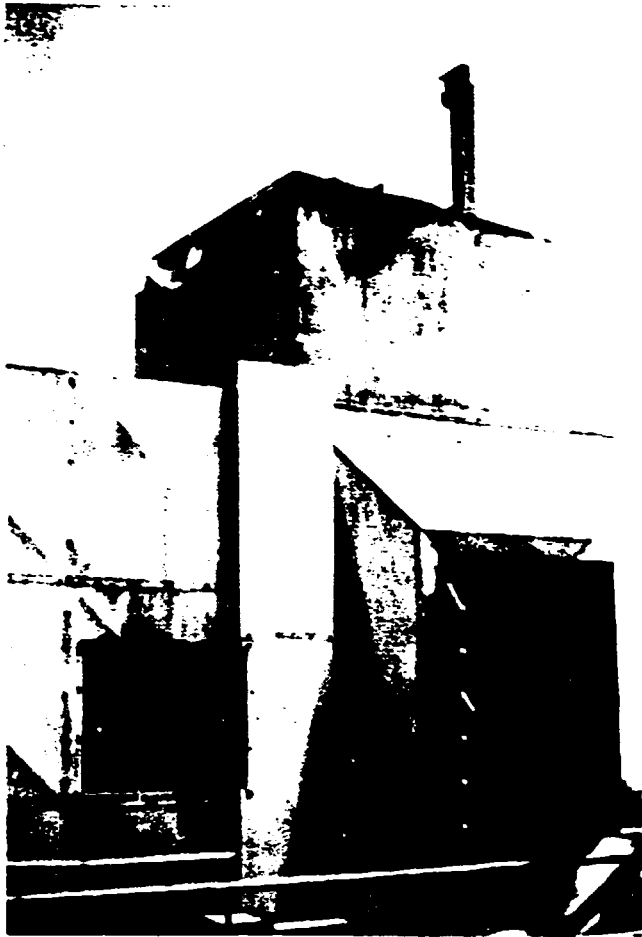

HEAT EXCHANGER CLEANING
SYSTEM TOP



HEAT EXCHANGER CLEANING
SYSTEM BOTTOM



HEAT EXCHANGER IN-LET INTERNAL
VIEW OF HEAT MIXING AREA



HEAT EXCHANGER IN-LET INTERNAL
VIEW OF HEAT MIXING AREA



HEAT EXCHANGER EXTERNAL
FUMES DUCT VIEW



HEAT EXCHANGER EXTERNAL
AIR FILTER VIEW

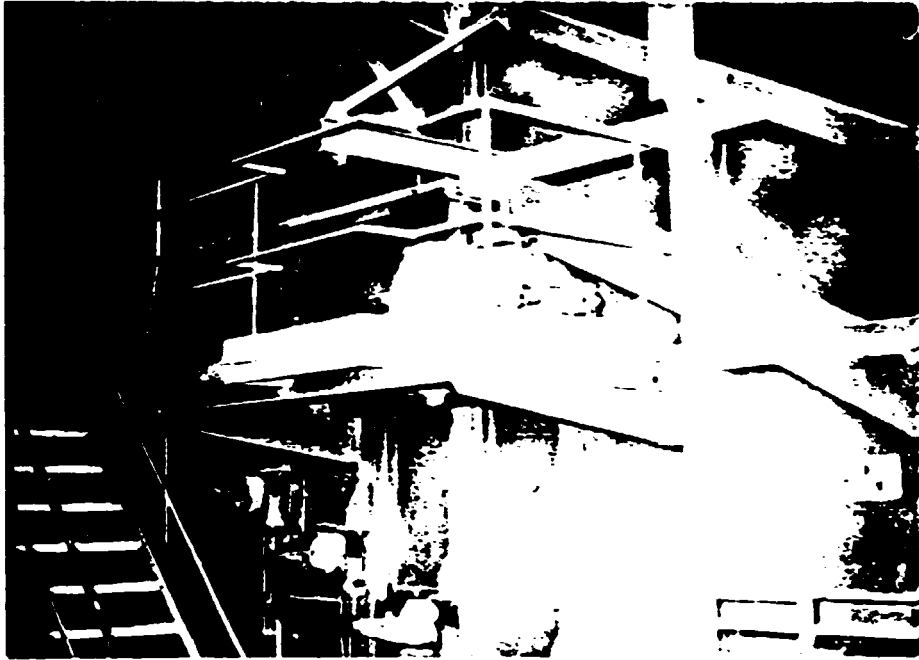

EXTERNAL VIEW OF FURNACE
WITH BURNER





ELECTROSTATIC PRECIPITATORS
GENERAL INTERNAL VIEW



GENERAL VIEW OF INTERIOR
OF ELECTROSTATIC PRECIPITATOR

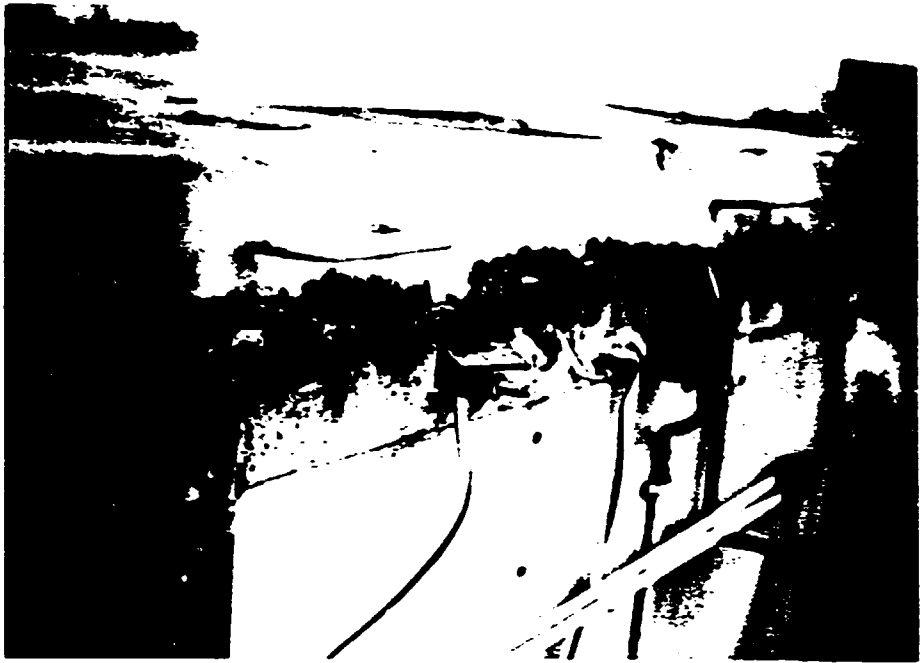

ELECTROSTATIC PRECIPITATORS
EXTERNAL VIEW OF HV CHAMBER S

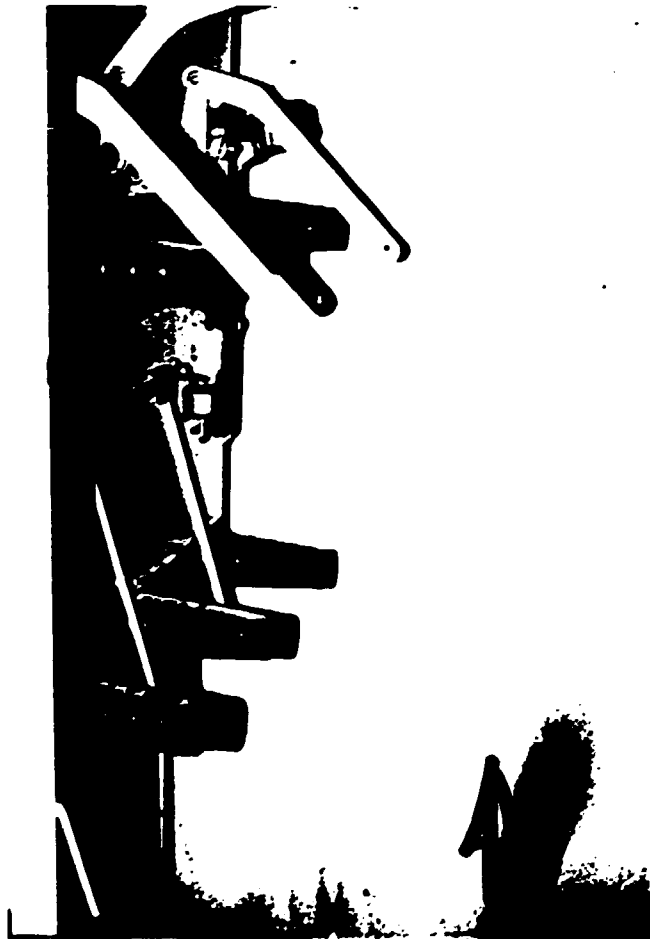

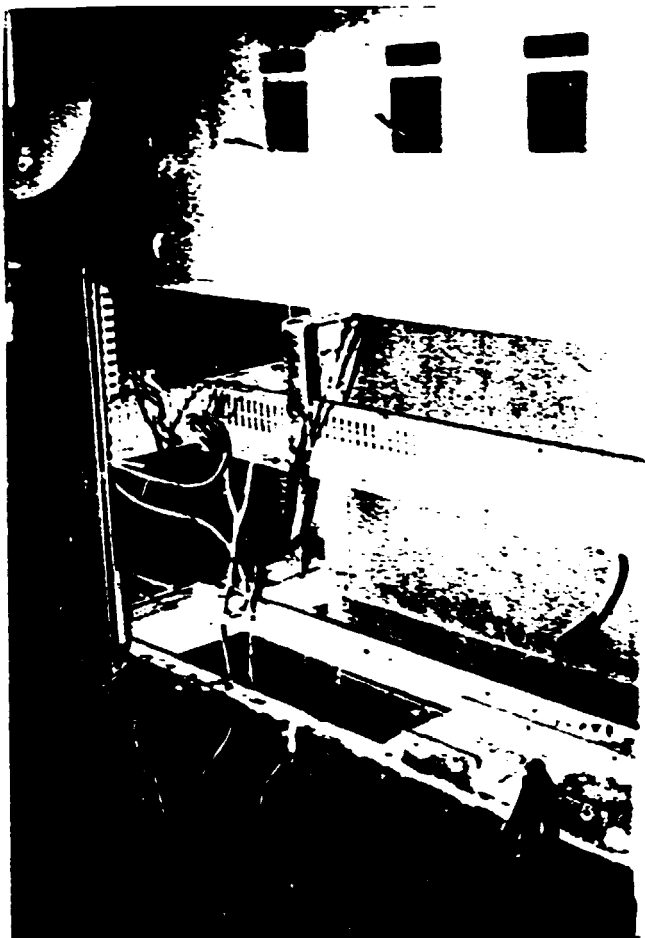

POWER DISTRIBUTION

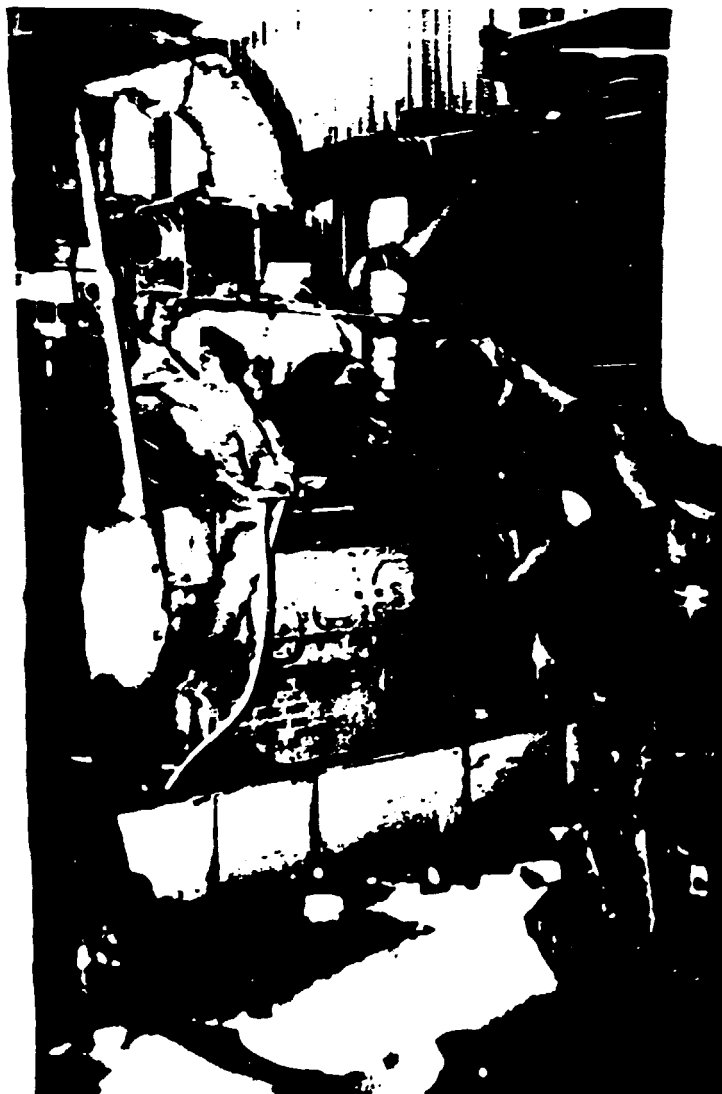



REMAINS OF GENERATING SETS



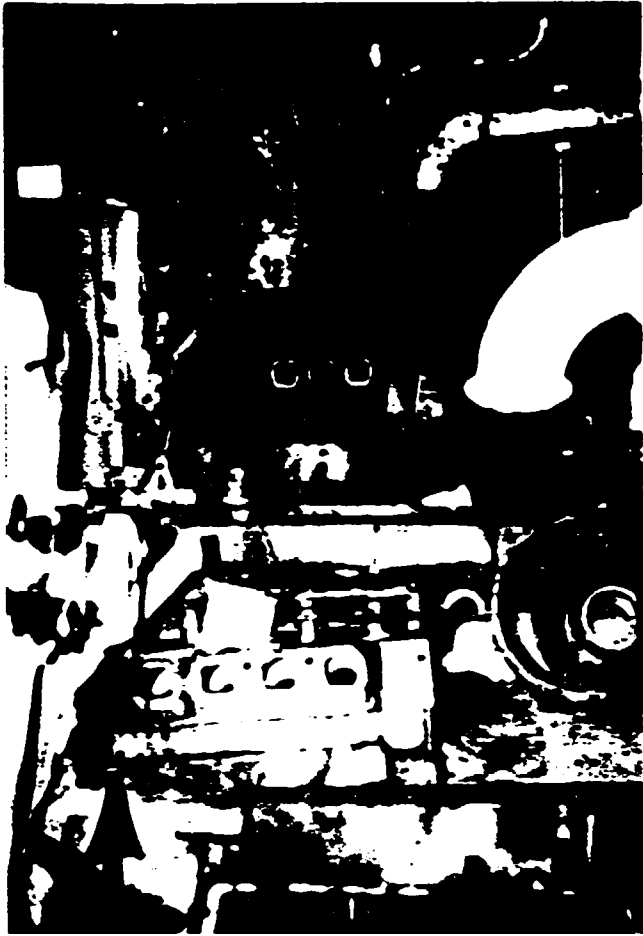

GENERAL LAY-OUT OF REMAINS
OF GENERATING SETS



VIEW OF COLLECTING PIT AND STRUCTURE

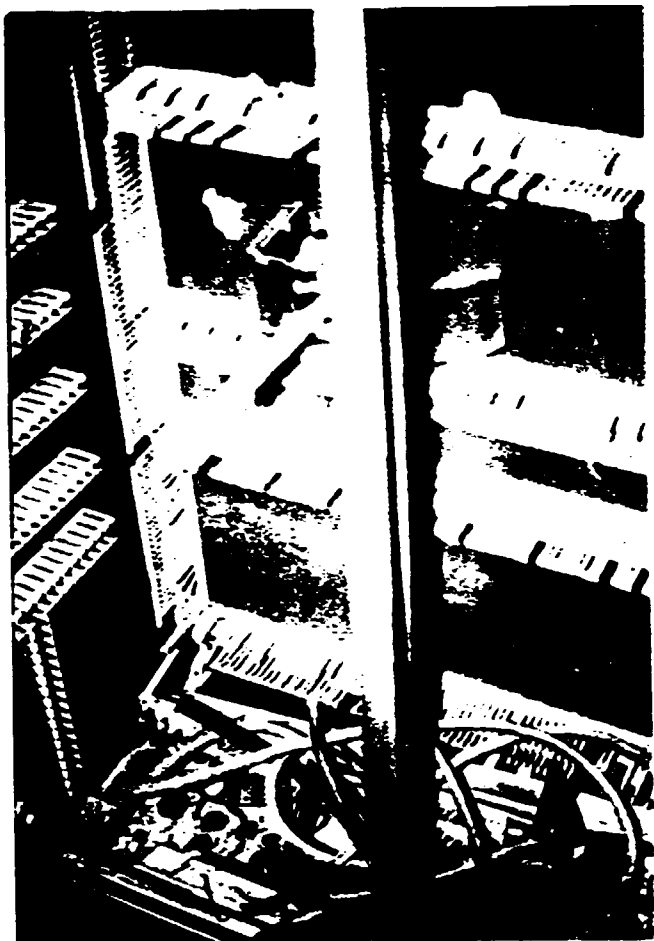

REMAINS OF CRANE PANEL



COVERING & HOISTING

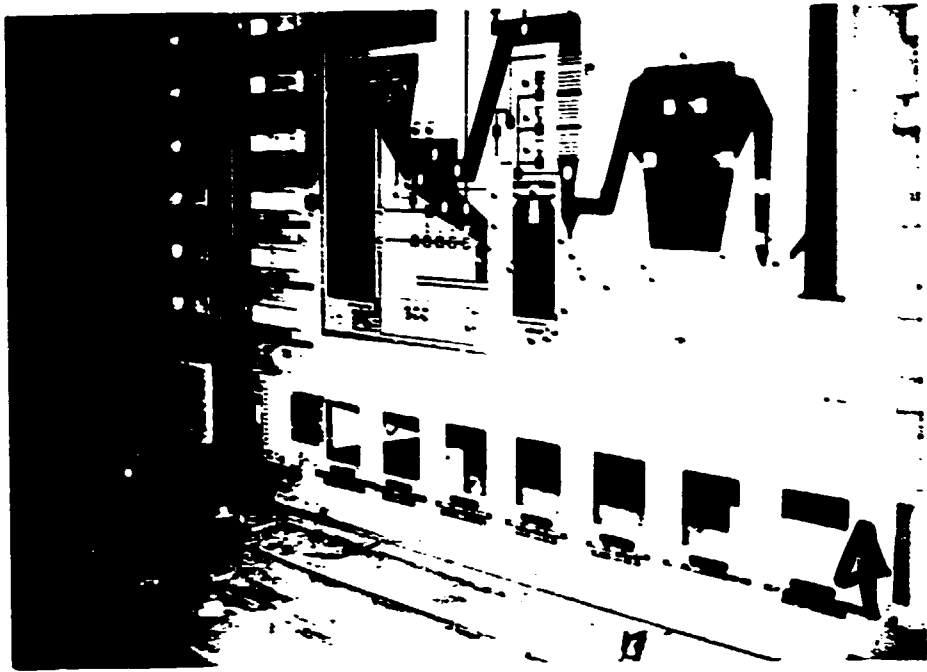

MAIN CONTROL ROOM - PANELS



CONTROL ROOM - OPERATORS

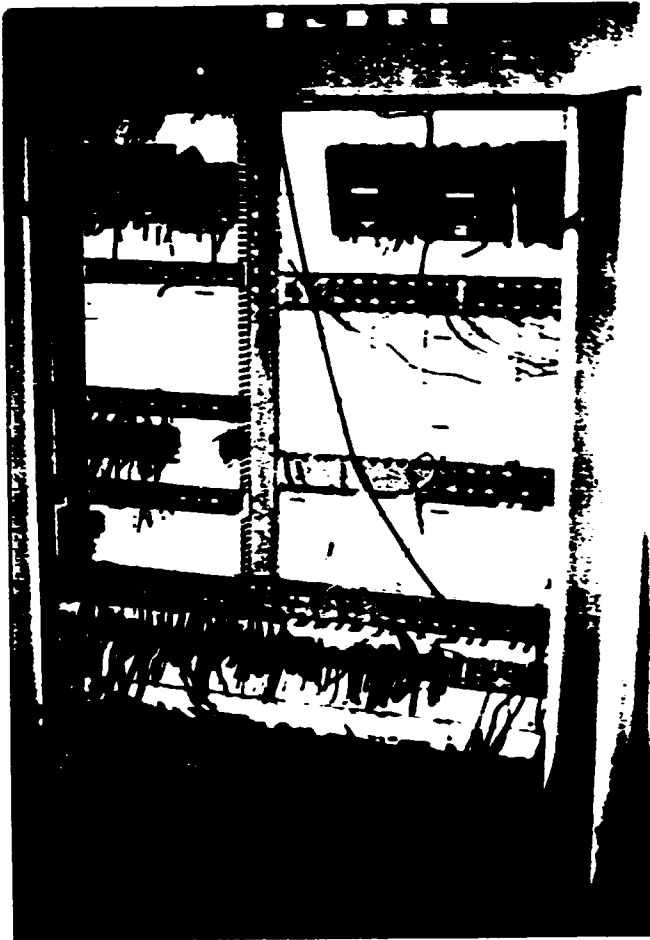

INCINERATING PANEL(S) LINE 1

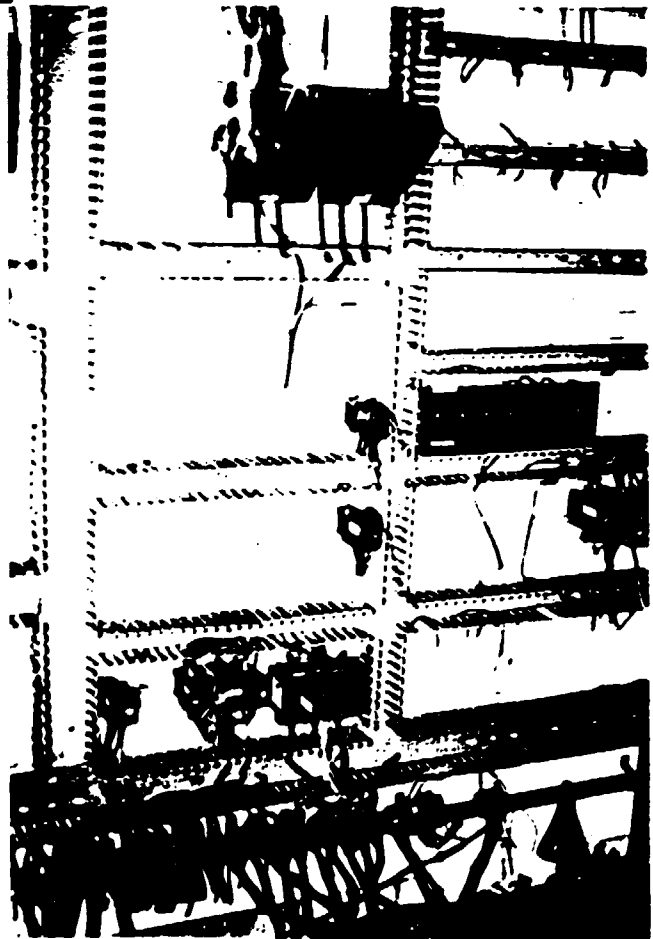

INCINERATING PANEL(S) LINE 2

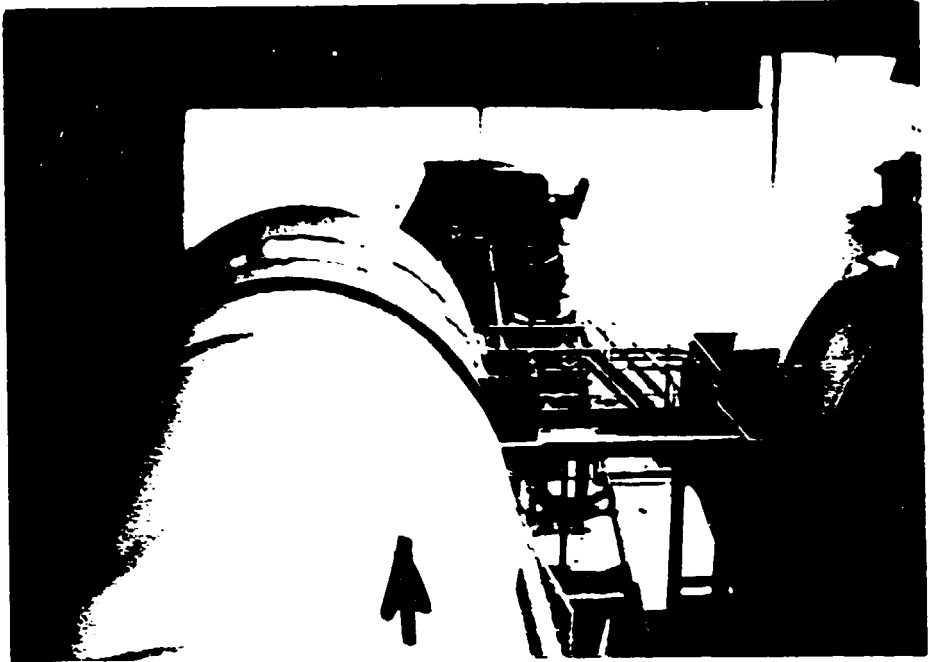

VIEW OF CONVEYOR BELT - FROM
COMPOSTING LINE



THESE PHOTOGRAPHS WERE
OBTAINED FROM THE
FOLLOWING SOURCE:

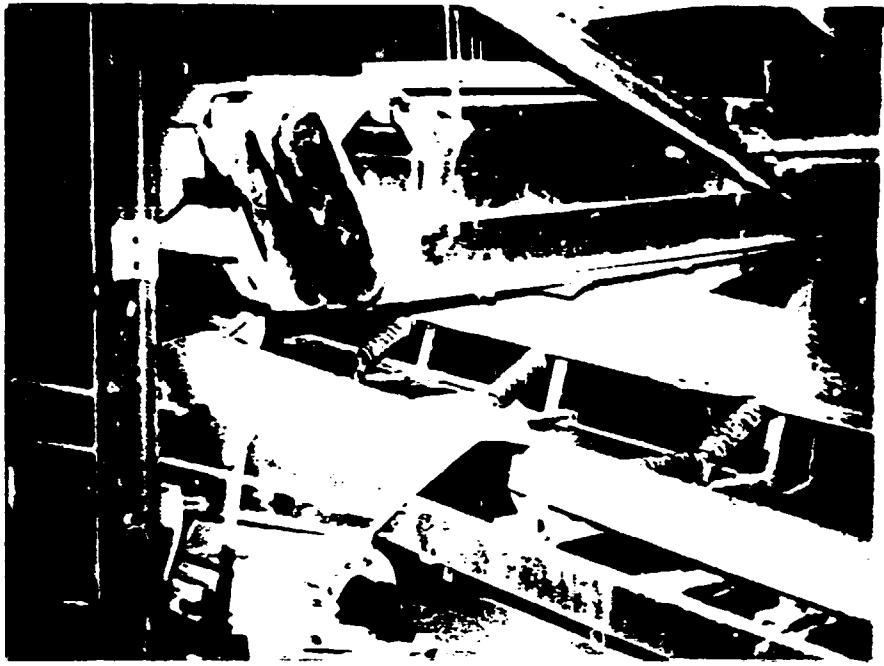

COMPOSTING LINE UNDER CYLINDER
CONVEYOR BELT



CONVEYOR BELT UNDER CYLINDER



CONVEYOR BELT TO COMPOST
DISCHARGING AREA

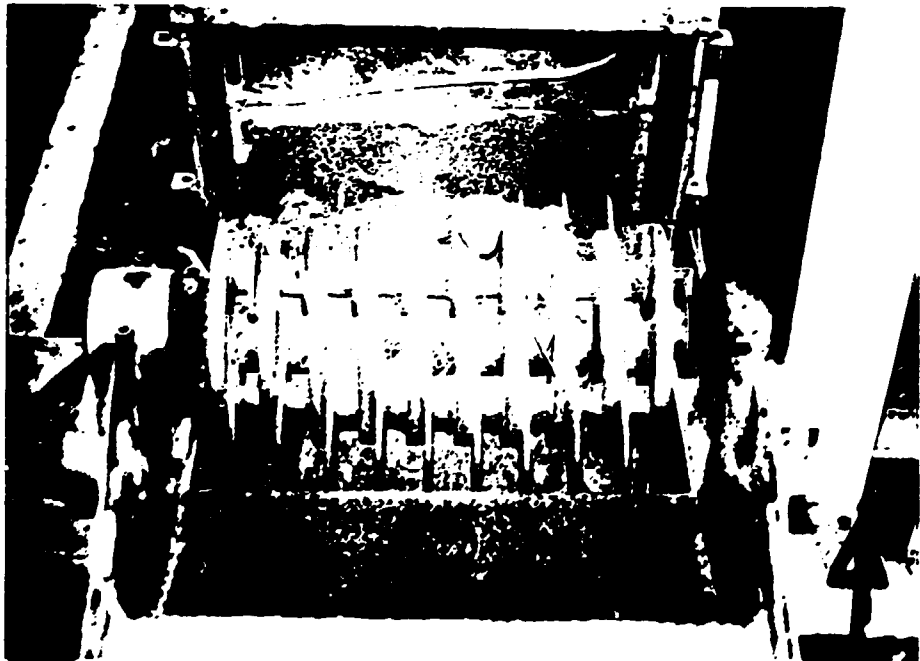

0000

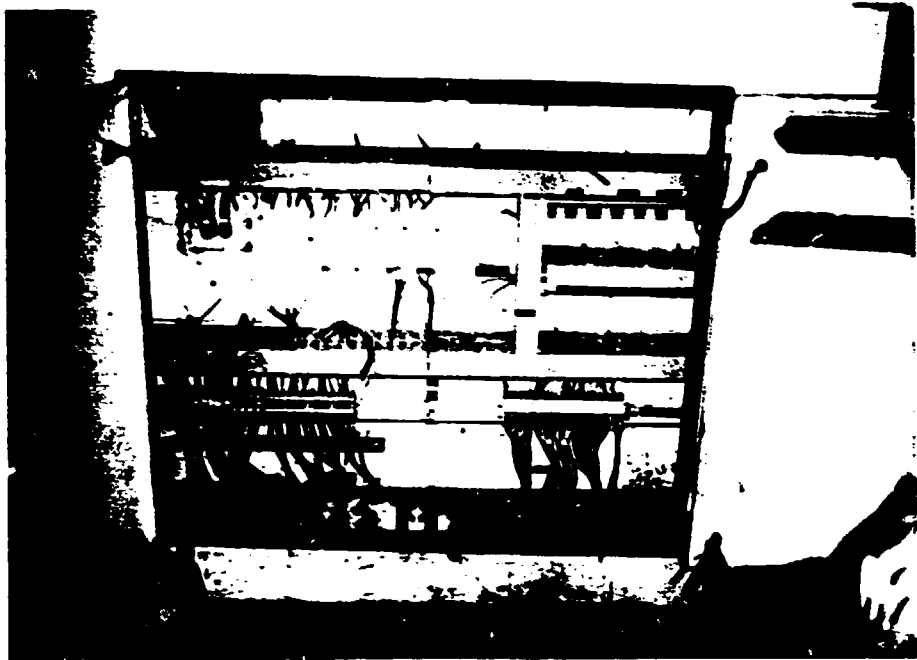

METAL PRESS CONTROL PANEL

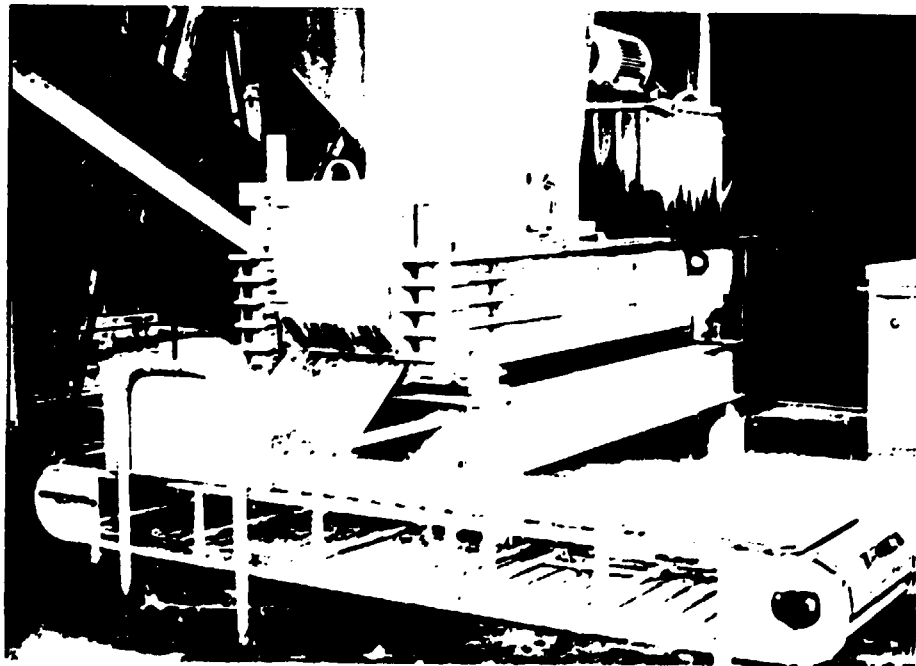

VIEW OF METAL PRESS



VIEW OF METAL PRESS



ELECTROSTATIC PRECIPITATOR
VIEW OF EXTERNAL INSULATION
DOOR OF HIGH VOLTAGE EQUIPMENT

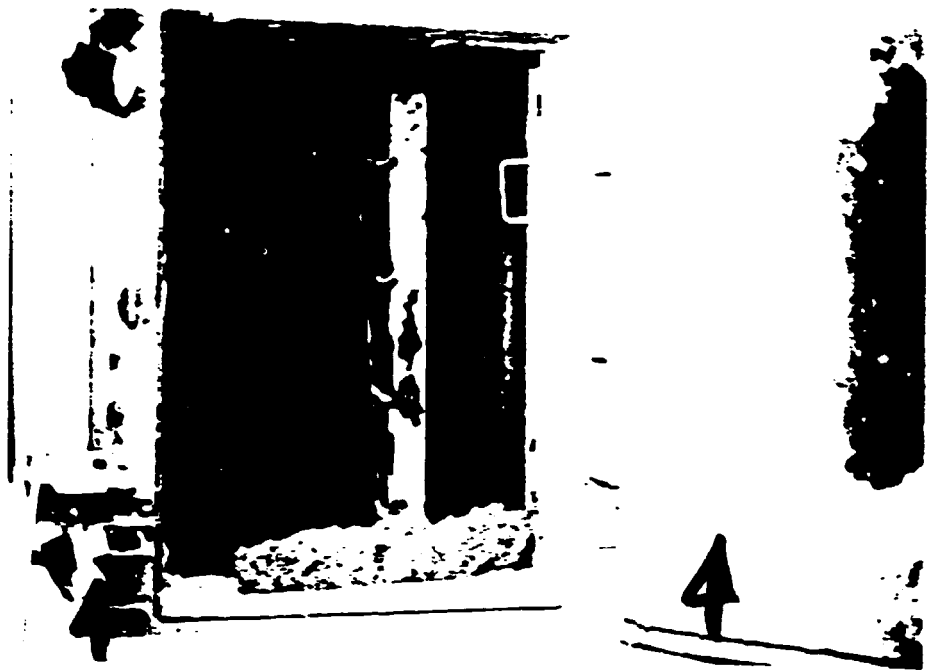

ELECTROSTATIC PRECIPITATORS
INTERNAL VIEW FROM INSPECTION DOOR



ELECTROSTATIC PRECIPITATORS
INTERNAL VIEW FROM INSPECTION DOOR

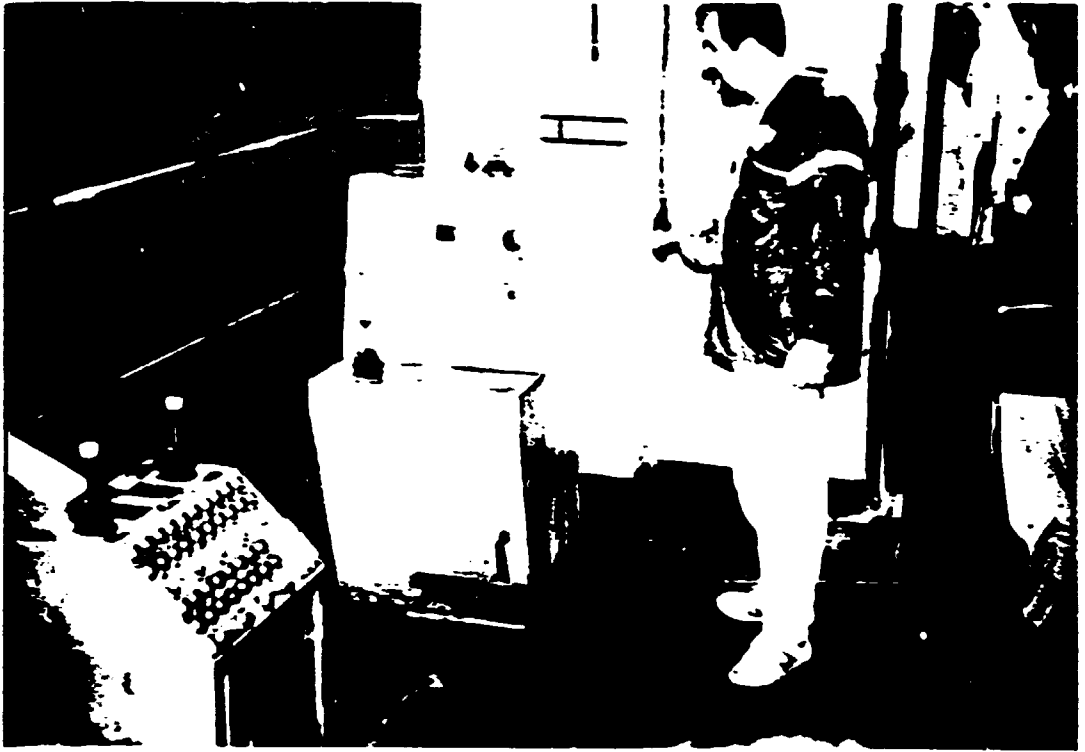

CONTROL CABIN (REFUSE PIT)

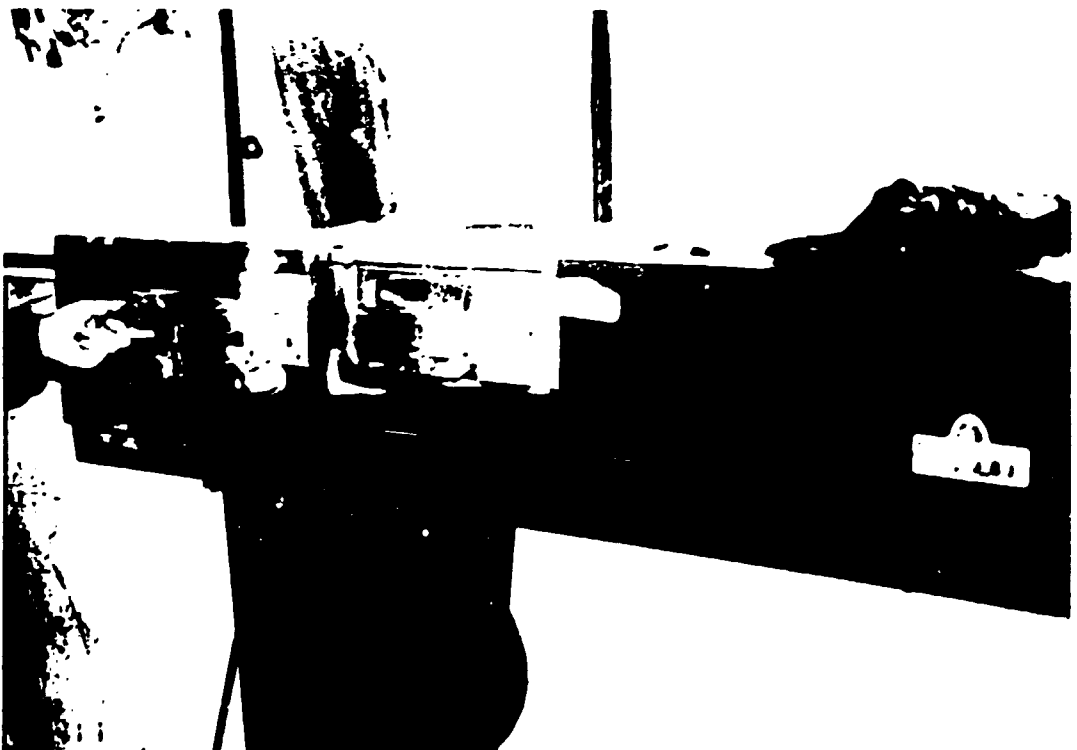

BRIDGE CABIN (SCALE)

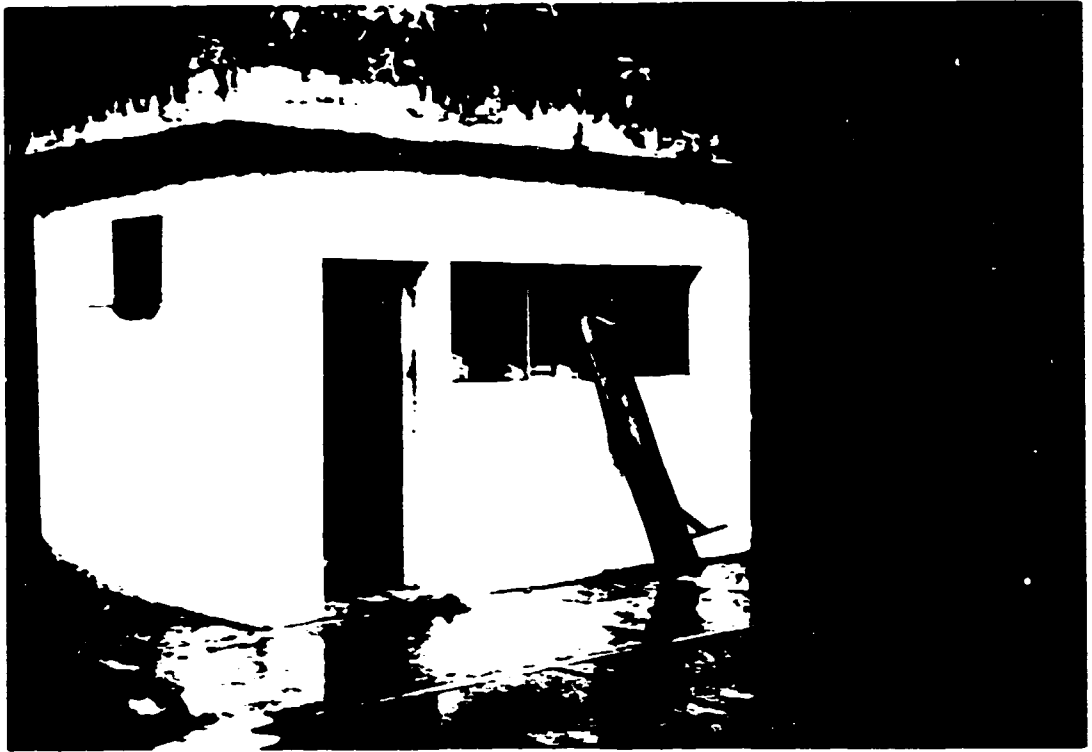

WEIGH BRIDGE CABIN



MAIN CONTROL ROOM (FIELD)



TRACTOR AND TRAILER





BALISTIC SEPARATORS



VIEW OF UNDER FURNACE AREA
SLAG TANK (NOTE: COMPLETELY
EMPTY)



TRANSFORMER STATION
(INTERIOR VIEW)

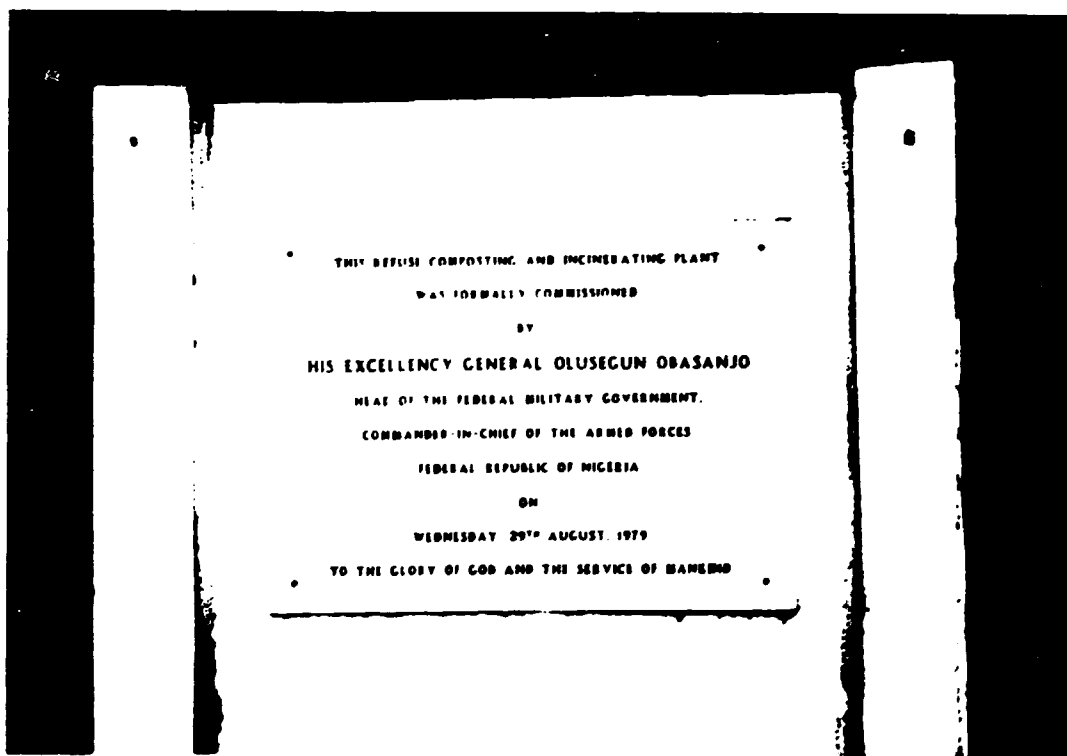

INCINERATOR PLANTS
IN LAGOS AREA

A

OSHODI

MARINI

COMPOSTING INCINERATING
PLANT

600 M.T/DAY

B

EBUTE METTA

CLAUDIUS PETERS

INCINERATING PLANT

375 M.T/DAY

C

SIMPSON STREET

CLAUDIUS PETERS

INCINERATING PLANT

375 M.T/DAY

SECTION 1

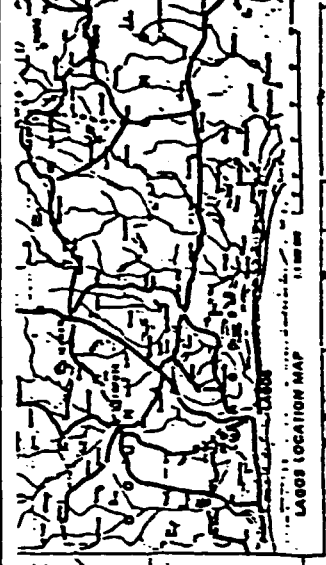
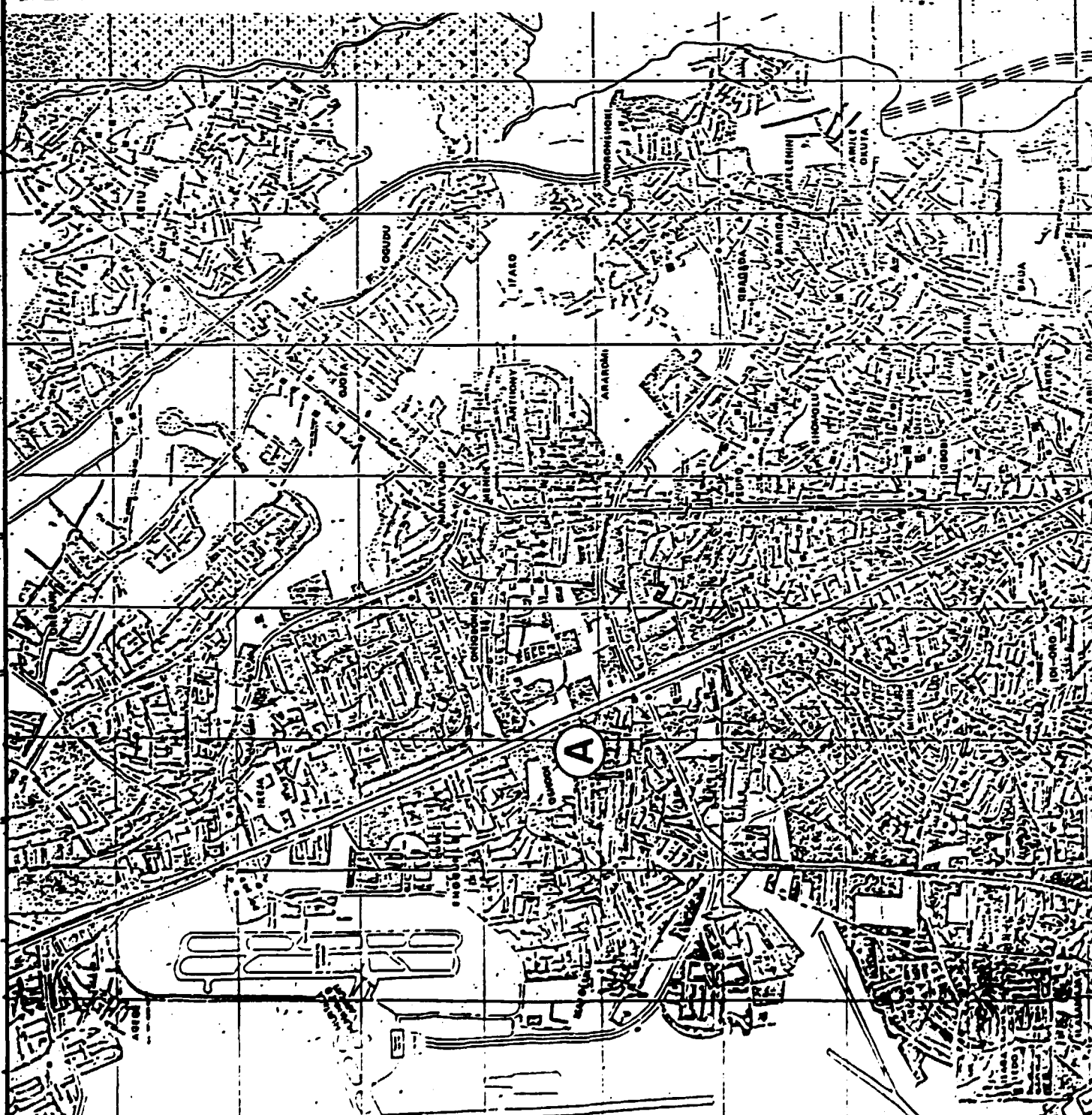

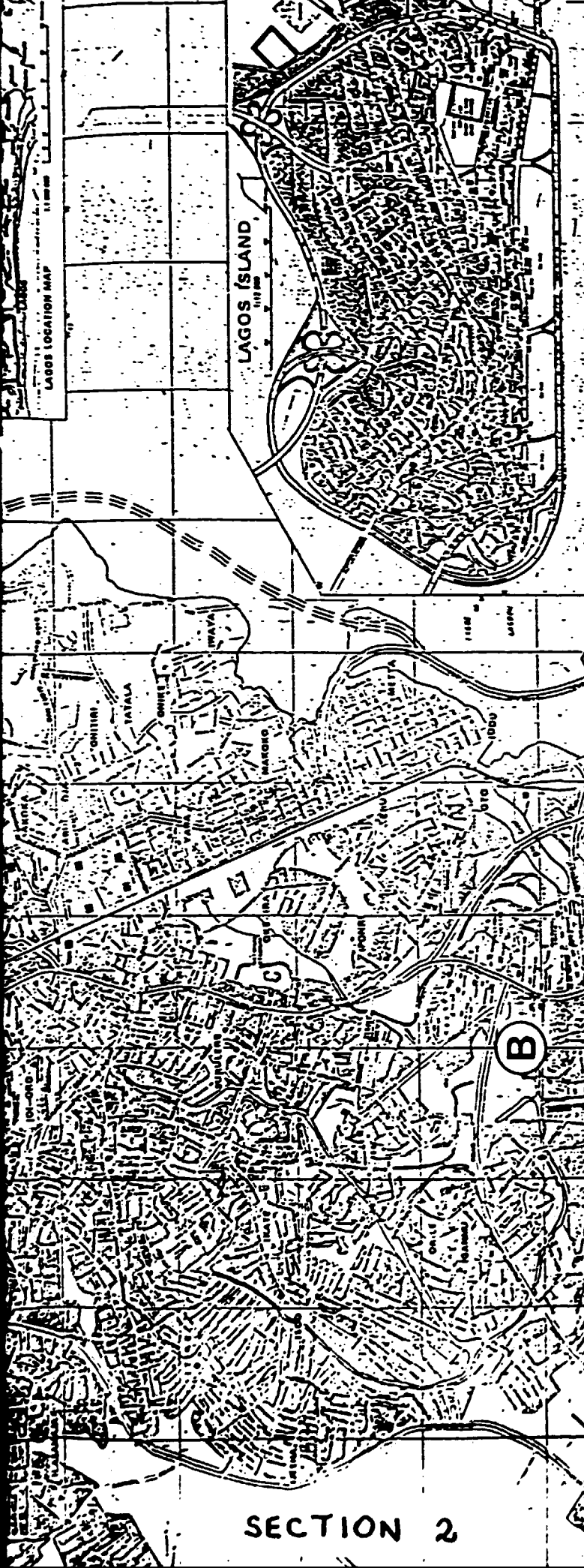

LAGOS LOCATION MAP

LAGOS ISLAND

B

SECTION 2

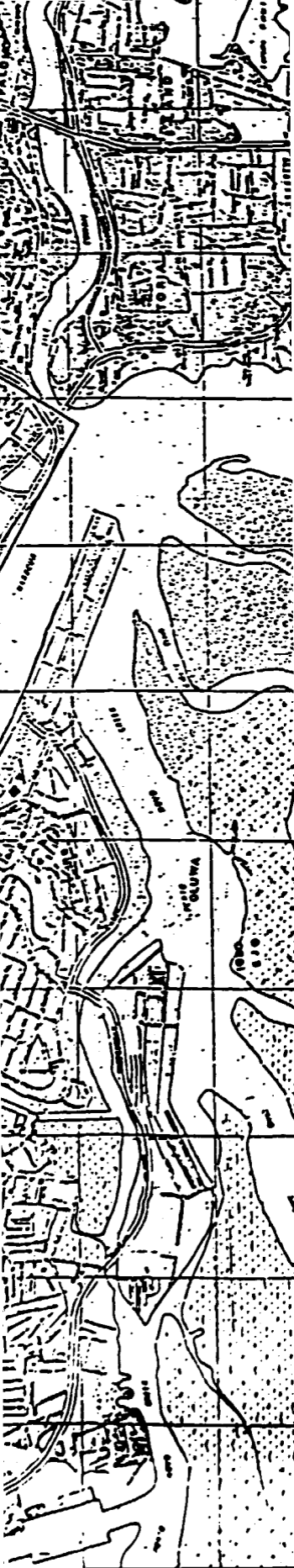

5. STATUS OF MUNICIPAL SOLID WASTE HANDLING AND MANAGEMENT

5.1 Landfills

5.2 Waste collection network

5.3 Hospital Waste Management

Attachment: 1) Mapping of landfills
2) Photographic survey

5. STATUS OF MUNICIPAL SOLID WASTE COLLECTION AND DISPOSAL NETWORK IN LAGOS AREA

5.1 LANDFILLS

An accurate survey of the existing landfills, and an overall analysis on actual collection and disposal of domestic/industrial refuse were carefully carried out by us during our first mission to Nigeria in respect of this matter.

1) Achakpo

- Uncontrolled landfill,
- without fence
- impermeabilisation absent
- children and women, especially, regularly comb the site in search of items of economic value to them, using their bare hands and without any protective clothing
- very close to residential area
- the landfill is used by inhabitants as a walkway
- one bulldozer is assigned to the landfill for the waste flattening
- periodical earth movement for coverage of the waste is not carried out
- access road heavily damaged

2) Isolo Mushin

- Uncontrolled landfill
- without fence
- impermeabilisation absent
- children and women, especially, regularly comb the site in search of items of economic value to them, using their bare hands without any protective clothing
- very close to residential area
- one bulldozer is assigned to the landfill for the waste flattening
- periodical earth movement for coverage of the waste is not carried out
- access road heavily damaged

3) Shomolu Anthony Village

- Located in industrial area
- partial fence with controlled access
- uncontrolled landfill
- impermeabilisation absent
- children and women, especially, regularly comb the site in search of items of economic value to them, using their bare hands without any protective clothing
- one bulldozer is assigned to the landfill for the waste flattening
- periodical earth movement for coverage of the waste is not carried out
- the landfill located in Municipal Lagos is sufficiently distant from residential area
- access road heavily damaged

4) Ojota

- Located in a large swampy valley along the express way
- uncontrolled landfill
- without fence
- impermeabilisation absent
- children and women, especially, regularly comb the site in search of items of economic value to them, using their bare hands without any protective clothing
- periodical earth movement for coverage of the waste is not carried out
- one bulldozer is assigned to the landfill for flattening of the waste
- access road heavily damaged

5) Abeokuta Expressway

- Uncontrolled landfill
- without fence
- located in the centre of residential area
- the periodical earth movement for coverage of the waste is not carried out
- one bulldozer is assigned to the landfill for flattening of the waste
- children and women, especially, regularly comb the site in search of items of economic value to them, using their bare hands without any protective clothing
- access road heavily damaged.

In addition to the five landfills inspected there are many ad hoc and temporary landfills all over the Metropolis.

They arise from the prompt non removal of dumped waste by the authorities.

These minor and temporary landfills are cleared haphazardly by the Waste Disposal Board whose employees use manual methods.

The five landfills, presently in use within Lagos area do not satisfy the specifications of sanitary landfill according to accepted international standards on sanitary rules and regulations and therefore can only be described as uncontrolled dumpings sites.

The neglected standards, common to all five landfills visited are summarized and described below:-

- The existence of the landfill, due to lack of necessary impermeabilization, is the origin of underground water pollution.
- Lack of the necessary fence, makes the landfill open to everyone constituting high risks for physical and sanitary safety.
- Lack of periodical earth movement for the waste coverage (soil protection) causes nasty smell from putrescence and decomposition.
- The volume of polluting liquid emanating from the waste increases substantially because of the lack of a suitable drainage system to convey the liquid and rain water, resulting in increased water pollution.
- Neglect of sanitary standards creates favourable conditions for insects and rats proliferation.
- Public health is constantly endangered by the activities of those who constantly comb bare handed and without any protective covering the landfills searching for items of economic value to them.

The distance from residential buildings does not respect any minimum standards, consequently thousands of inhabitants live in close proximity to unsanitary and unhealthy conditions.

All the landfills presently in operation within Lagos (ACHAKPO - ISOLO - OJOTA - SHOMOLU - ABEOKUTA EXPRESSWAY) are neither planned nor controlled, hence they do not respect any Sanitary/Hygienic Standards.

On the basis of above conditions, it appears absolutely inappropriate to collect refuse from homes, public squares and roads and dump them in these fills where they decay and emit bad odours apart from constituting a breeding ground for insects and worms. All these, occur within the territorial boundary of Lagos which creates an imminent hazard to millions of inhabitants of the city.

5.2 WASTE COLLECTION NETWORK

Collection of waste in Lagos metropolis is inefficient cumbersome and time consuming.

The inefficiency of the service is due to the following factors:-

- A) Lack of small, medium and big size containers in which the inhabitants should dump their refuse. Such containers should be provided with necessary device to enable automatic loading into the refuse collection trucks, thereby avoiding an excessive waste of time and energy in the process of loading.
- B) Different sizes of refuse compaction trucks are however in use like the old medium size GEESINK trucks and the new small Calabrese trucks. It is necessary to increase the number of these trucks in order to phase out numerous uncovered types that constitute a nuisance in themselves.
- C) At present solid waste is often heaped in ad hoc and temporary sites randomly located in various parts of Metropolis Lagos in both business and residential areas. The waste dumps are subsequently manually loaded on trucks and transferred to Municipal Landfills. These ad hoc and temporary waste dumps constitute a dangerous hazard to the public. The refuse collectors spend a lot of time clearing these dumps.

D) Containers used for the collection of refuse are 200 Lt drums which are heavy and not easy to handle.

Collection of refuse is carried out in very difficult conditions. The process is inefficient with negative consequences for public health and sanitation.

Urban solid waste collection in Lagos faces enormous difficulties due to the non-availability of adequate number of refuse collection trucks and mechanised containers for automatic loading.

As a result, the entire system lacks the organisation and ability to collect large heaps of refuse which in most instances are loaded manually into the few available trucks.

It is therefore necessary to undertake a total reorganisation of the entire collection network that will involve the provision of adequate and mechanised means of collection which will bring about an efficient refuse collection system operating in conformity with internationally accepted hygienic standards.

5.3 Hospital Waste Management

In the whole analysis of waste collection network it has been found that, due to the lack of thermal treatment plant, hospital refuses are constantly dumped into the existing landfills without using any particular precaution.

As very well known the use of landfill is not the right way to overcome the problems of treating hospital waste.

The thermal destruction technology, is currently, one of the most widespread and effective methods to eliminate toxic content from the waste and installation of this particular plant having a relatively limited cost, to eliminate at least the most dangerous refuses, should be also envisaged.

Final Conclusions

The envisaged final solution is not limited to the reactivation/commissioning of the three incinerating plants. It also should include the reorganisation of the landfills, which is highly desirable and recommended.

The whole reorganisation consists of the four main aspects of waste collection and disposal in Lagos State.

- A) Complete rehabilitation of solid waste collection service with adequate purchase of containers and trucks.
- B) Establishment, within the border of Lagos Municipality, of transfer stations suitable for receiving solid wastes in the shortest possible time and satisfying acceptable offloading standards.
- C) Establishment of sanitary landfills located some 5 km from the border of Lagos Municipality and within a distance of a minimum of 1 km from the nearest village or residential area.

The sanitary landfill should be built according to hygienic sanitary standards (fence, impermeabilization, periodical earth coverage, drainage system, combined water system, asphalt access roads and yards, waste weight control, controlled landfill).

Cost for the realization of a sanitary landfill, having a capacity of 800 M.T. per day has been estimated at U.S. \$ 2,000,000.

- D) Establishment of suitable plant for the special treatment of hospital waste.
Thermal destruction system is a complete process, widely proven, which offer high destruction efficiency and total environment safety.

The foreseen plant, for which technical features are described below, is employing the thermal craking of organic substances with poor oxygen support.

It takes place in the pyrolytic chamber through partial combustion of waste (controlled combustion).

Pyrolysis gases (carbon oxide, hydrogen, hydrocarbons etc.) are burnt into the post-combustion chamber and are completely depurated from unburnt residuals.

The plant will be able to treat a board spectrum of hospital waste as:-

- Bacteriological substances
- Chemical and biological ferments
- Chemical and biological laboratory residues
- Chemical reactive agents
- Medicine and drugs
- Anatomical specimen
- Rotten food

It has been estimated that cost investment for the installation of the "thermal plant" having an incineration capacity of 1000 kgs/hour should not exceed U.S. \$ 1,000,000

Technical features

Type of furnace:	Static with controlled combustion
Caloric power of the waste	Kcal/kg 2000
Nominal capacity for the thermal furnace	Kcal/h 1.800.000
Incinerating working hours capacity	kg/h 900
Volume of the post-combustion chamber	cu.mt 20
Auxiliary fuel	gasoil
Thermal capacity	Kcal/kg 10200
Flue gas temperature on exit from post combustion chamber	C 950

Flue gas content of O ₂	‡ 11.3
Volume of flue gas in the post combustion chamber at 950 C	cu.mt/hour 22.900
Volume of the post combustion section	cu.mt 12.7
Residence time in post combustion section	sec. 2
Post combustion section	sq.mt 0.63
Flue gas velocity in the entry section	mt/sec. 10

WASTE LANDFILL
IN LAGOS AREA

① ABEOKUTA

② SHOMOLU ANTHONY VILLAGE

③ ISOLO MUSHIM

④ OJOTA

⑤ ACHAKPO

SECTION 1

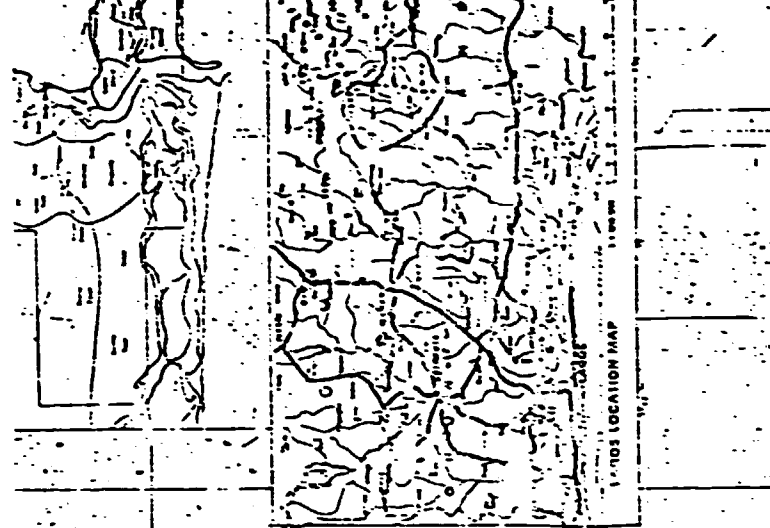
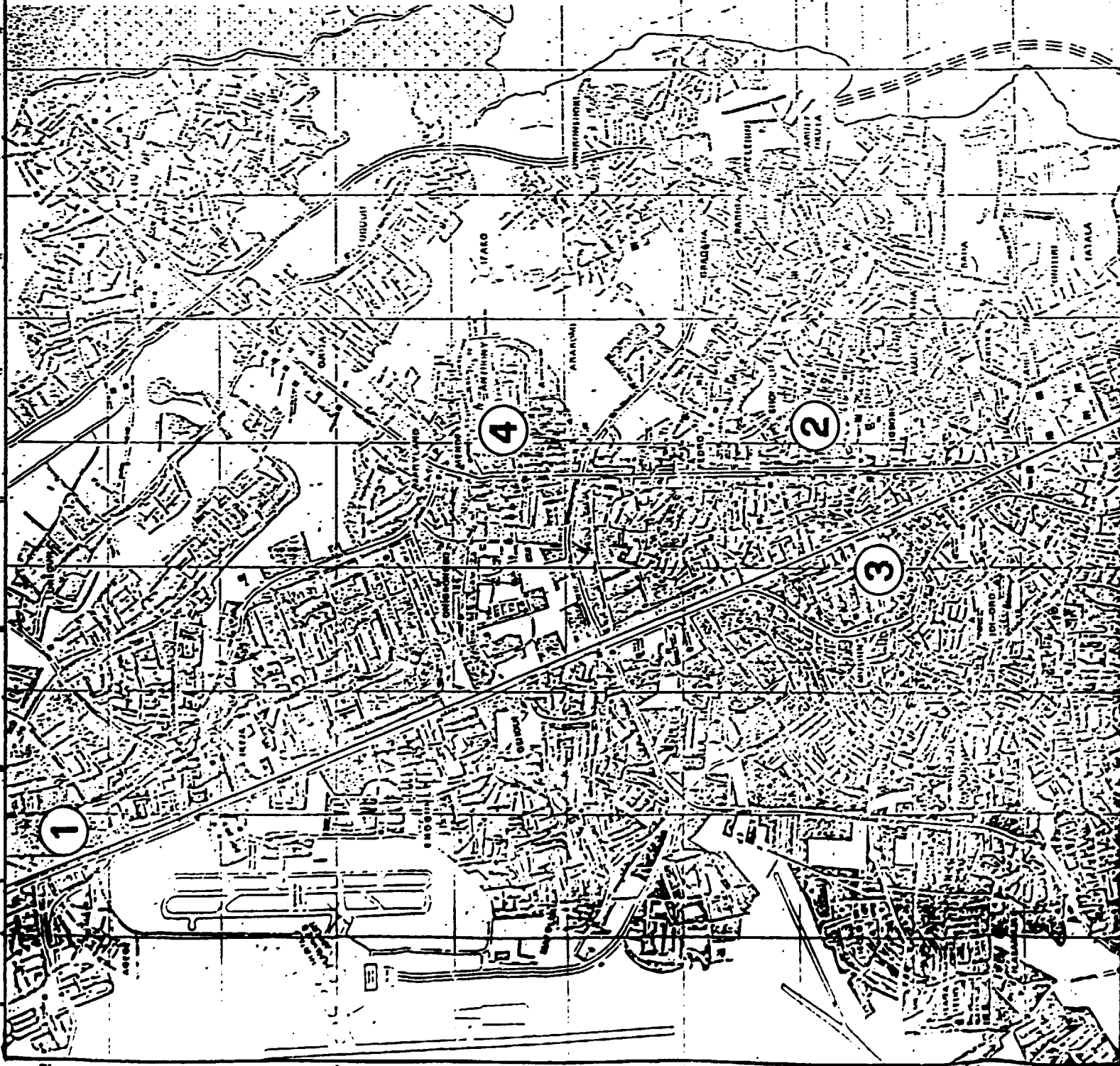

LANDFILL PHOTOGRAPHIC DOCUMENTATION

ABEOKUTA







LANDFILL PHOTOGRAPHIC DOCUMENTATION

SHOMOLU ANTHONY VILLAGE

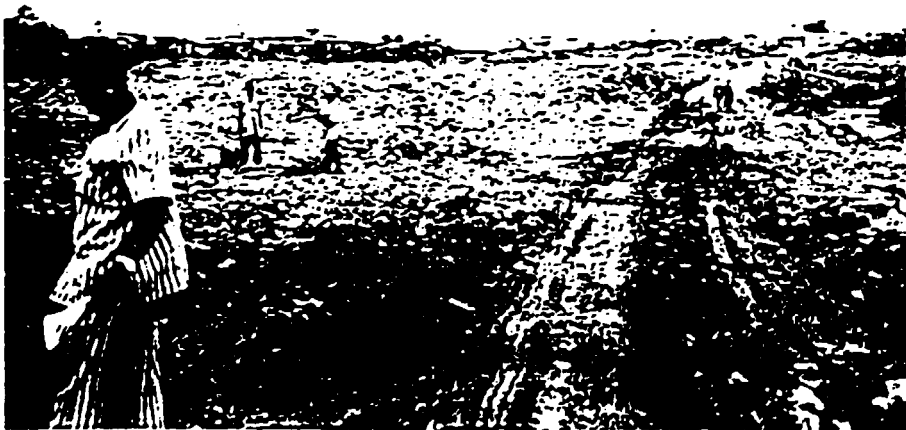
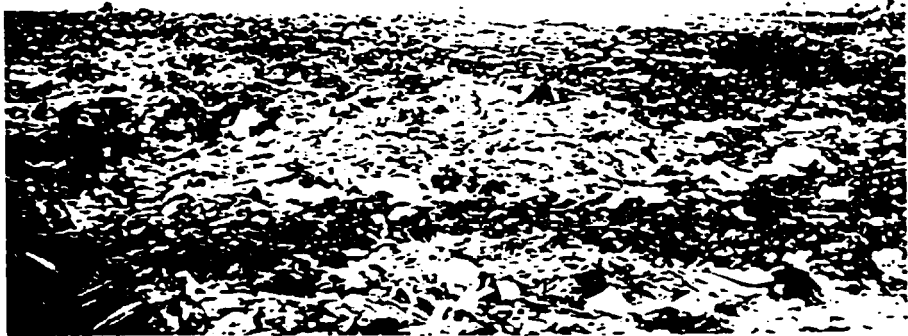



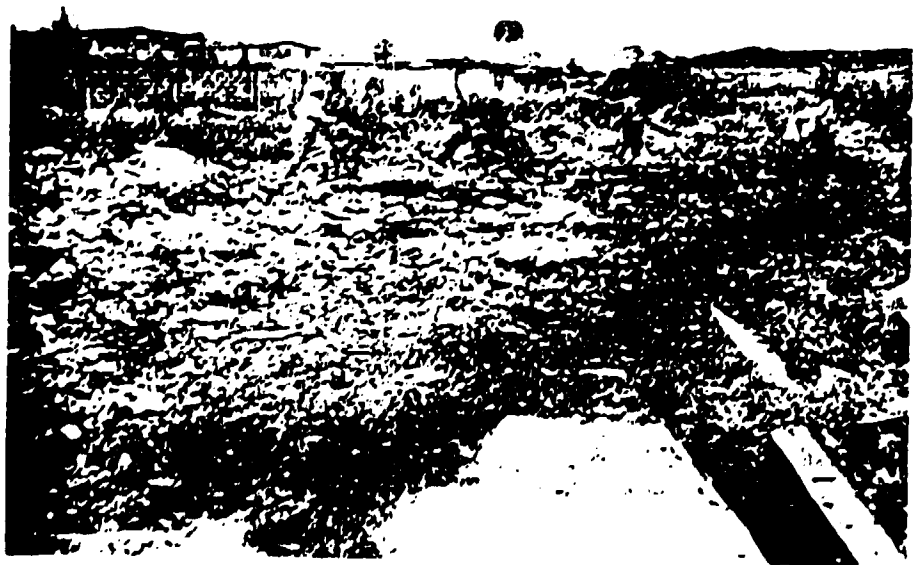

LANDFILL PHOTOGRAPHIC DOCUMENTATION

ISOLO MUSHIM

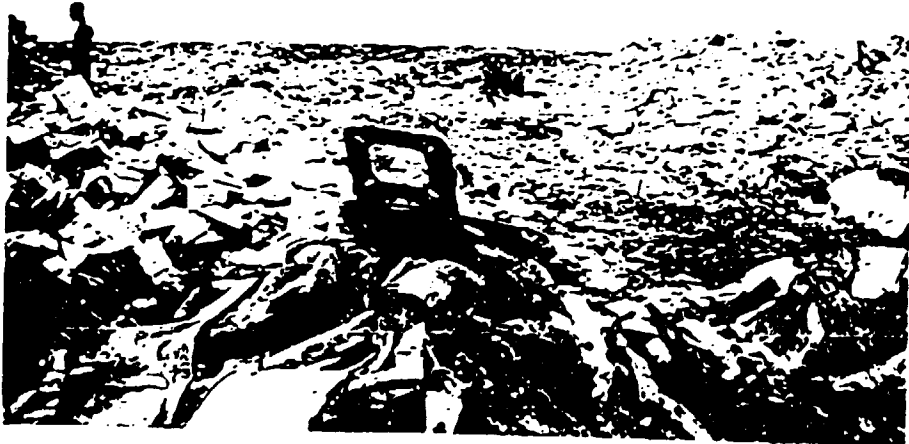
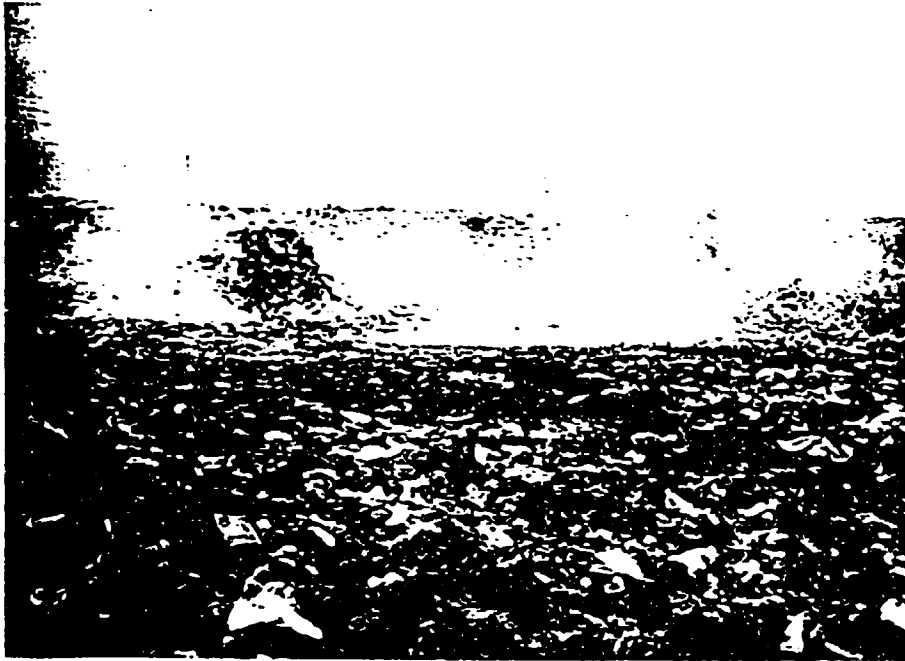





LANDFILL PHOTOGRAPHIC DOCUMENTATION

OJOTA

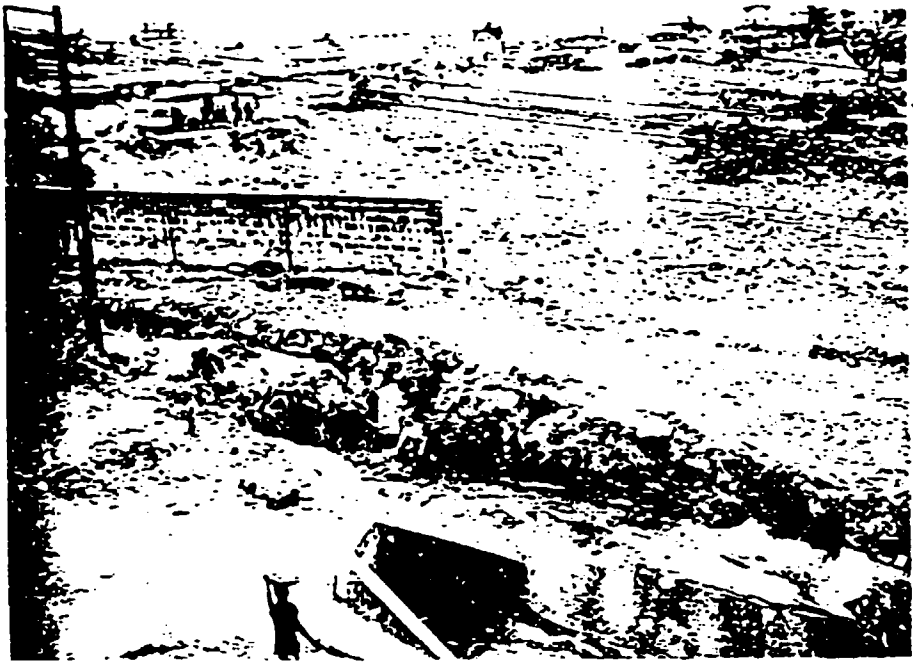

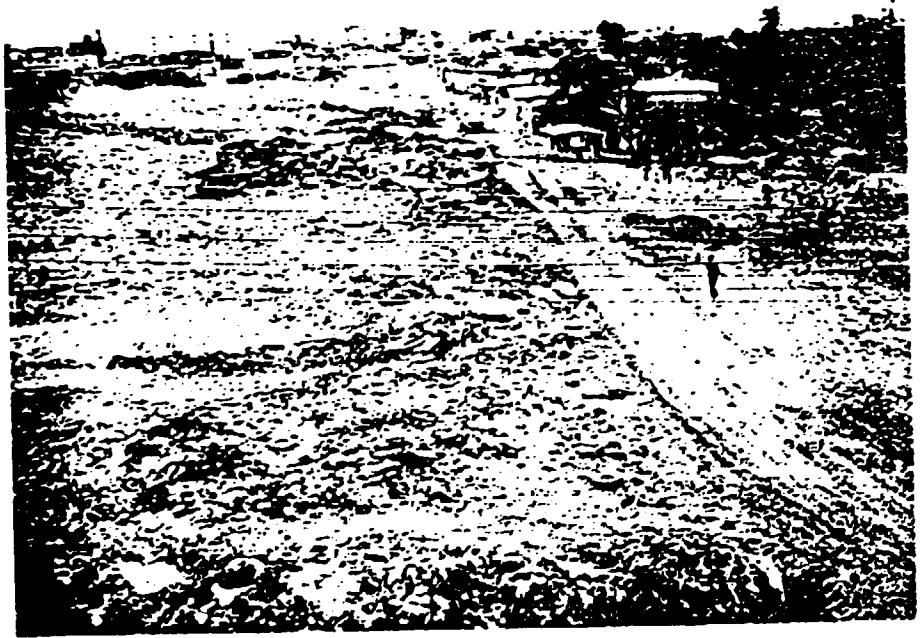

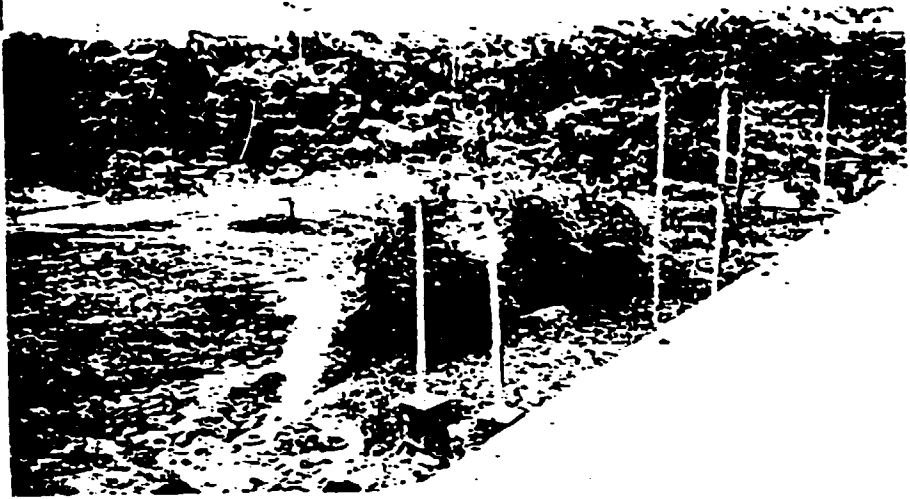

LANDFILL PHOTOGRAPHIC DOCUMENTATION

ACHAKPO



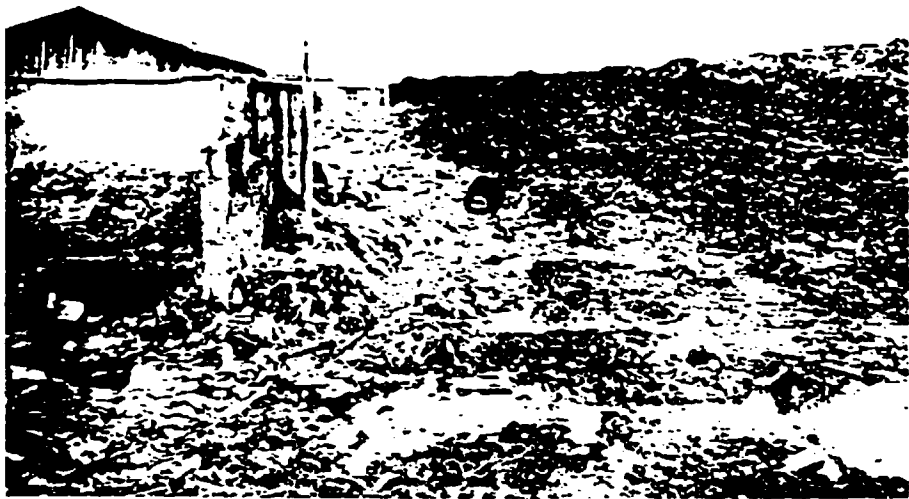



6. ASSESSMENT OF POSSIBLE SCENARIOS

On the basis of data collected and studied, described in previous paragraphs, before the evaluation of possible scenarios for a rehabilitation project of the three incineration plants, the following points should be taken into consideration:

- Revamping of the existing incineration plants has to meet the minimum emission levels of pollutants that current technologies can achieve. This means that a complete flue gas cleaning system should be provided (Tab. 8).

According to our experience we believe that the dry flue gas cleaning system is the most suitable and appropriate technology to resolve the probable problems likely to emerge in the treatment of any eventual liquid flow stream.

- Waste heat recovery (Tab. 6) can be very useful because of the local situation of the electric power supply. In addition, this will affect consistently and positively the reduction of the plant operating costs.
- M.S.W. management should be considered as an integrated system that consists of several activities working simultaneously. In particular, incineration system rehabilitation means that collection and handling system, recycling, landfills and waste water treatment must be in operation according to the present regulations.
- In the ultimate case of the three plants, all working at full capacity, their joint capacity will not be able to process all M.S.W generated in Lagos.
- The conversion of existing incineration areas into transfer loading station could be of interest. At the moment, this important service is completely missing.
- The integration of M.S.W. incineration facility with the overall waste management system would be of strategic service to overcome emergency conditions due to epidemic diseases.
- The Claudius Peters' plant at Odaliki Street as already pointed out in the Committee report in 1987, cannot be revamped because of its inappropriate location in the middle of a densely populated residential area.

On the basis of above evaluations (see Tab. 7), supported by our experience, we have envisaged the three options, as explained in detail in Table 5a - b - c, and which we recommend the local Authorities to consider.

Our conclusions and recommendations emanate from the technical survey and physical checks of the plants coupled with the existing condition of the waste disposal and collection service in Lagos and are informed by our experience and knowledge of international standards to formulate proposals for suitable and efficient waste management services in Lagos metropolis.

Should the sale of the plants as scrap metal be considered viable by the local Authority we wish to inform the reader that a relevant evaluation is always difficult, especially when, as in this case, a considerable dismantling cost is involved. In Europe, due to the high cost of manpower and transport on a dismantling operation of the likely magnitude would represent a substantial expenditure for which the income from the sale of the scrap metal would not justify.

On the basis of likely reduced local costs for the dismantling operation and higher second hand value, we do believe that some income could come from the sale as scrap, but it would be negligible, compared to the total loss of the initial capital investment.

In Lagos State, hospital waste, at present, are dumped in landfill without using any particular precaution and this situation cannot be accepted in the long terms because of the substantial negative environmental impact caused by this indiscriminated disposal.

Unfortunately, due to the very tight financial resources and in some way, due to the lack of a consolidated "cultural basis" an adequate treatment of such waste has never been seriously considered.

On the basis of our knowledge, we do believe, that some corporation could be interested to participate to the financing of the investment necessary for reconverting the plants and we are in the opinion that to this possibility more accurate attention should be given.

OPTION A

CLAUDIUS PETER IN SIMPSON STREET

- Reactivation of the plant
- Improvement of its incineration technology by addition of "waste heat recovery unit" (Tab. 6) and of "Flue gas treatment unit" (Tab. 8)
- Sale of the existing cooling system and multicyclone unit.

CLAUDIUS PETER IN ODALIKI STREET

- Recovery of materials and equipment for use as spare parts (moving grates, stoker, refractories, generators material, motors, mechanical components of mobile machine etc.) in the twin plant in Simpson St.
- Sale of unutilized parts.
- Possible use of the concrete structure as public building (gym, swimming pool, medical rehabilitation center).

MARINI PLANT

- Reactivation of the compost line
- Improvement of the compost technology to obtain refined fertilizer with acceptable standard. (Tab. 9)
- Utilization of refractories material as spare parts for Claudius Peter in Simpson Street.
- Sale of incinerating appliances and equipment.

By adopting this alternative, future expansion including installation of a small capacity toxic and hazardous waste incinerator plant, is also foreseen in order to provide complete waste incineration facilities.

PROPOSED SCENARIO

OPTION A

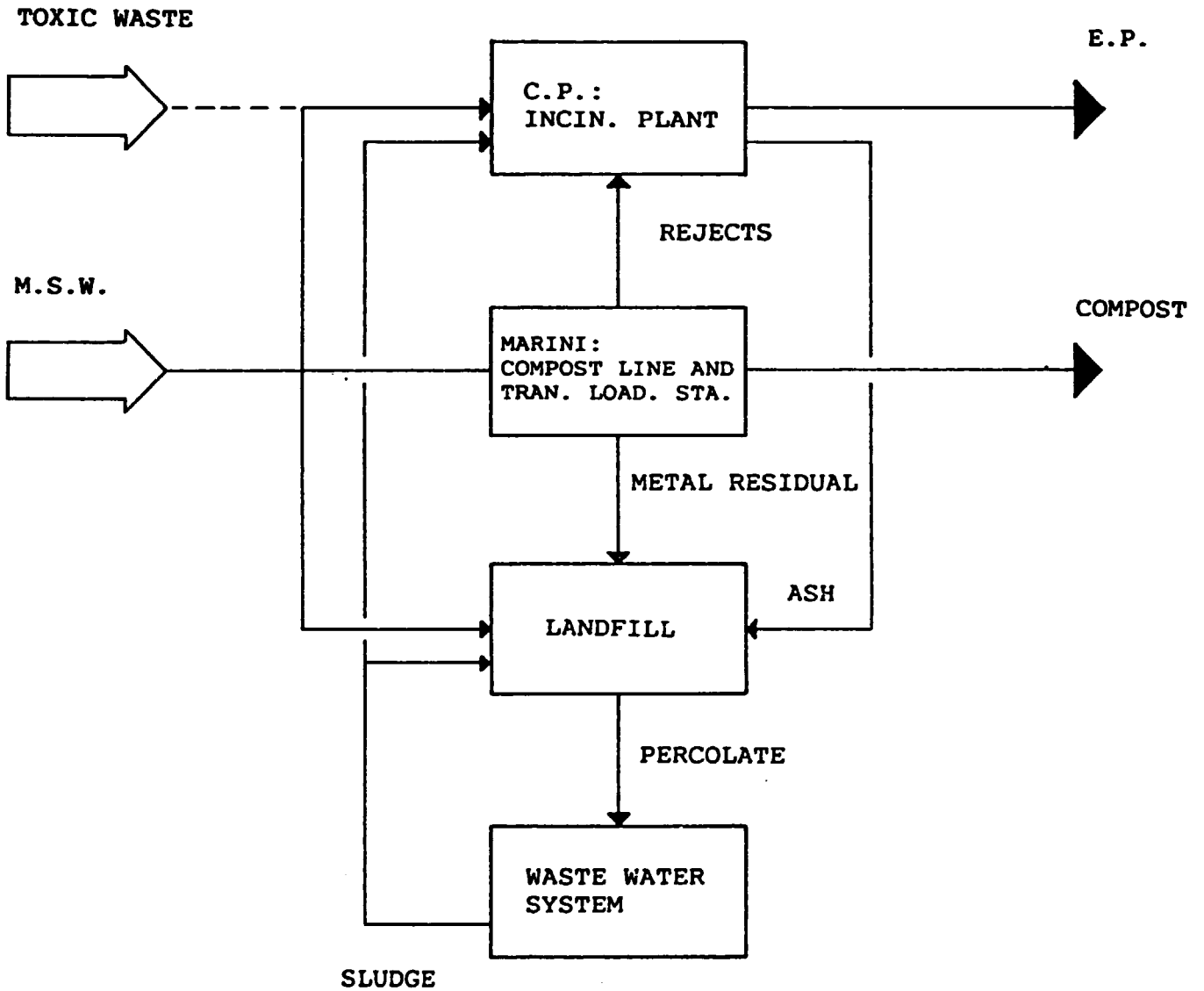

TAB. 5-a

OPTION B

CLAUDIUS PETER IN SIMPSON STREET

- Reutilization of electric power generating units for Marini plant.
- Recovery of refractories materials for use in Marini plant.
- Sale of the remaining equipment.
- Transformation of the area for "Transfer loading station".

CLAUDIUS PETER IN ODALIKI STREET

- Reutilization of electric power generating units for Marini plant.
- Recovery of refractories materials for use in Marini plant.
- Sale of the remaining equipment.
- Possible use of the concrete structure as public building (gym, swimming pool, medical rehabilitation center).

MARINI PLANT

- Reactivation of the plant
- Improvement of incineration technology by addition of "waste heat recovery unit", (Tab., 6) and of "Flue gas treatment unit" (Tab. 8).
- Improvement of the existing composting line (Tab. 9).

PROPOSED SCENARIO

OPTION B

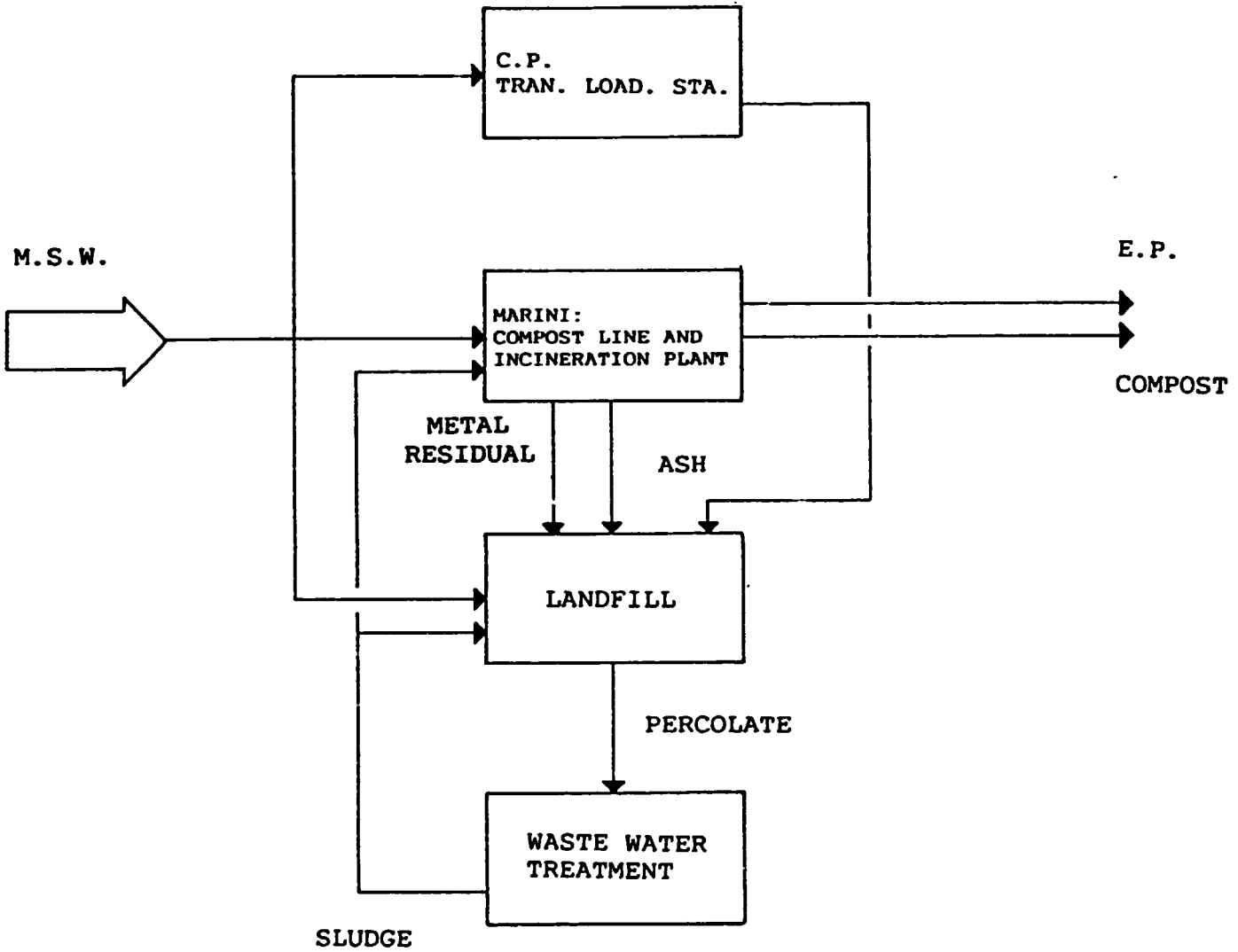

TAB. 5-b

OPTION C

CLAUDIUS PETER IN SIMPSON STREET

- Reutilization of electric power generating units for Marini plant.
- Sale of the remaining equipment.
- Utilization of the area for "Transfer loading station"

CLAUDIUS PETER IN ODALIKI STREET

- Reutilization of electric power generating units for Marini plant.
- Sale of the remaining equipment
- Possible use of the concrete structure as public building (gym, swimming pool, medical rehabilitation center).

MARINI PLANT

- Reactivation of the composting line
- Improvement of the existing composting line (Tab. 9).
- Utilization of the area for "Transfer loading Station".

PROPOSED SCENARIO

OPTION C

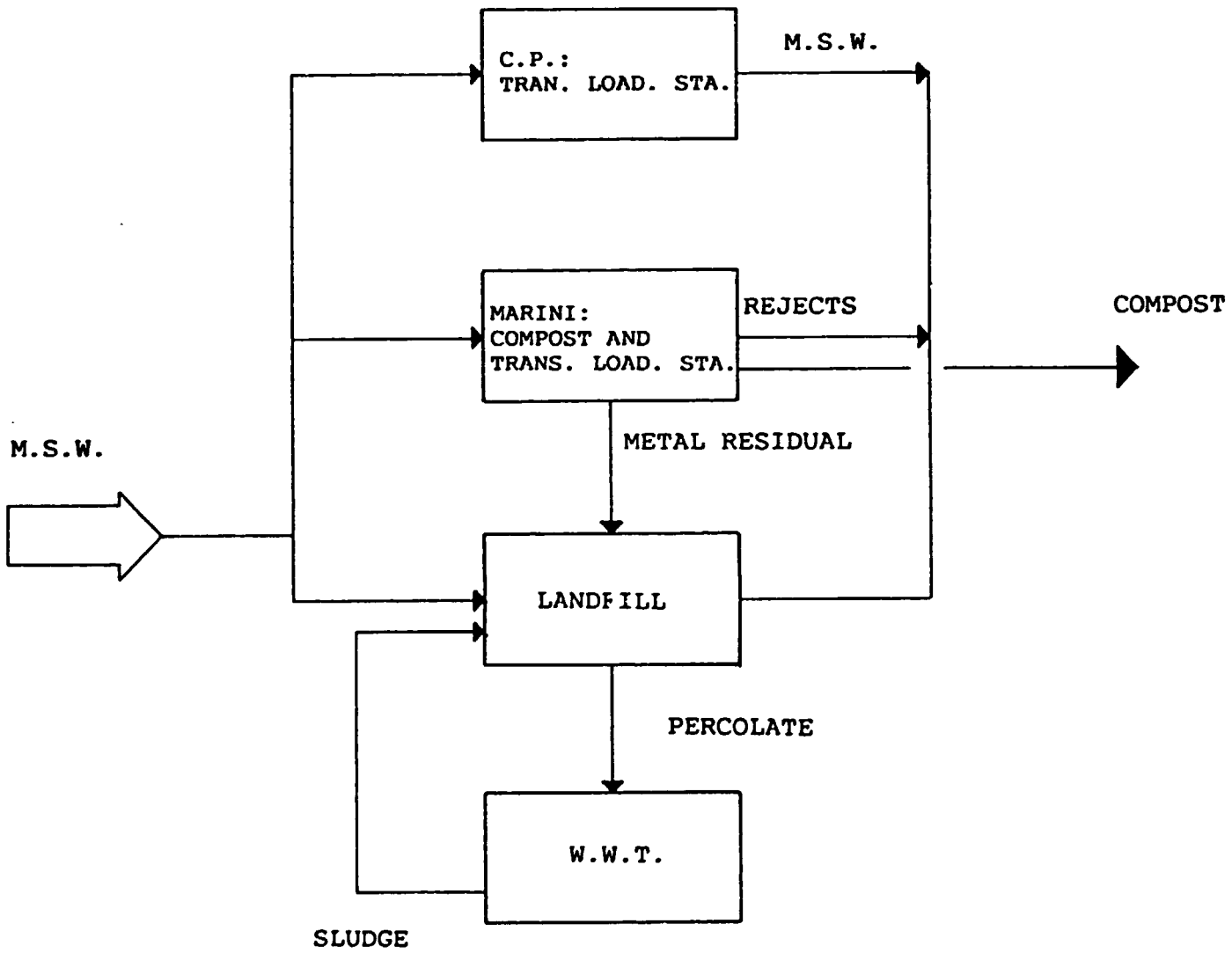

TAB. 5-c

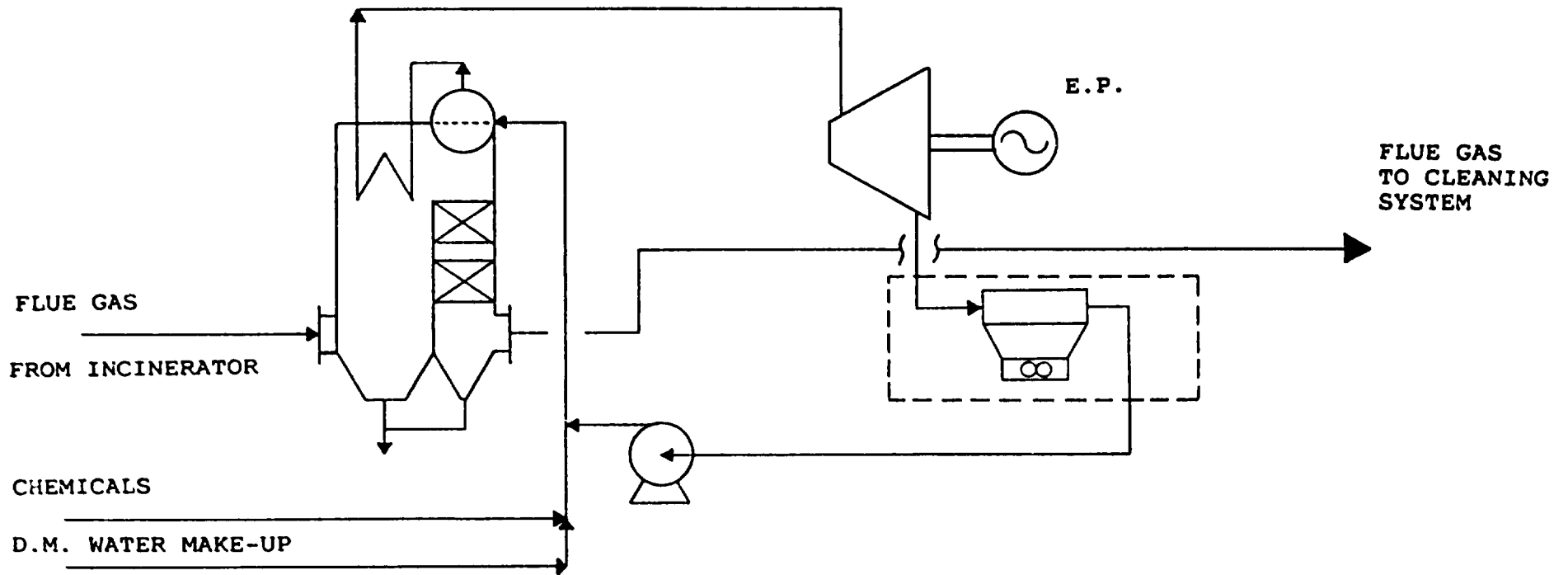

BOILER

B.F.W.
PUMPS

STEAM
TURBINE

AIR
COOLER

TAB. 6

WASTE HEAT RECOVERY UNIT (W.H.R.U.)

A) ACTUAL

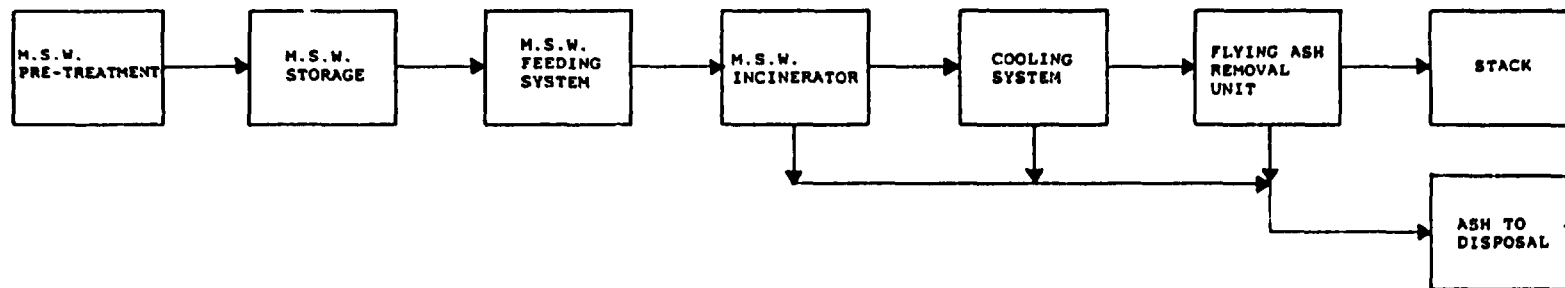

B) AFTER REVAMPING

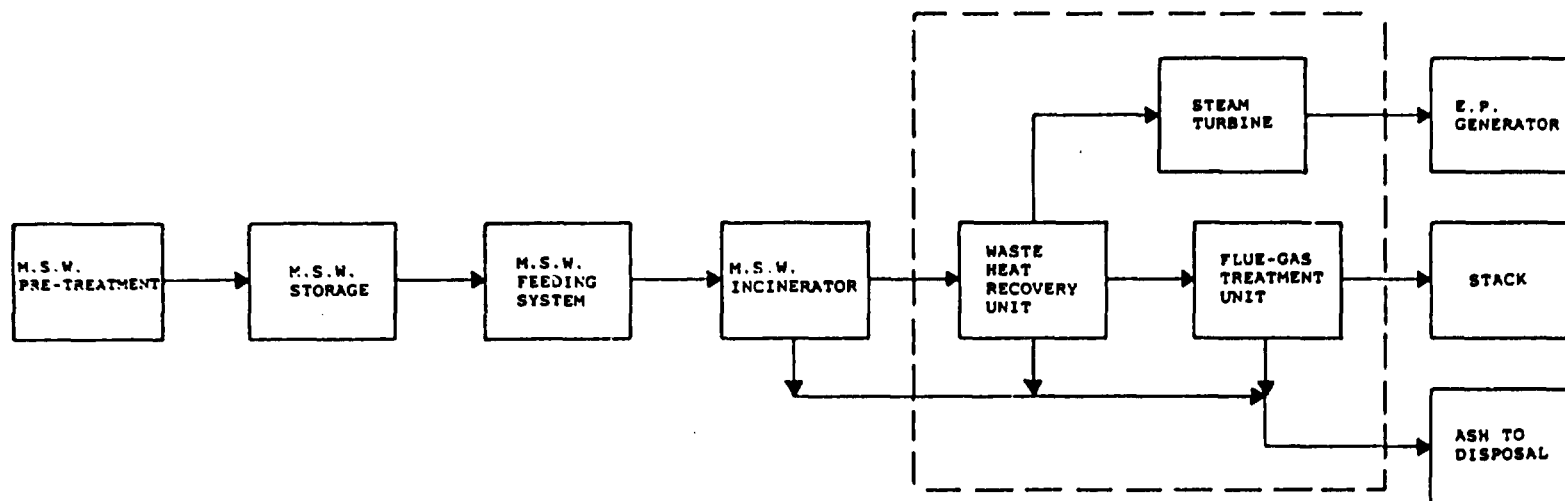

TAB. 7

INCINERATION PLANTS FLOW SCHEME

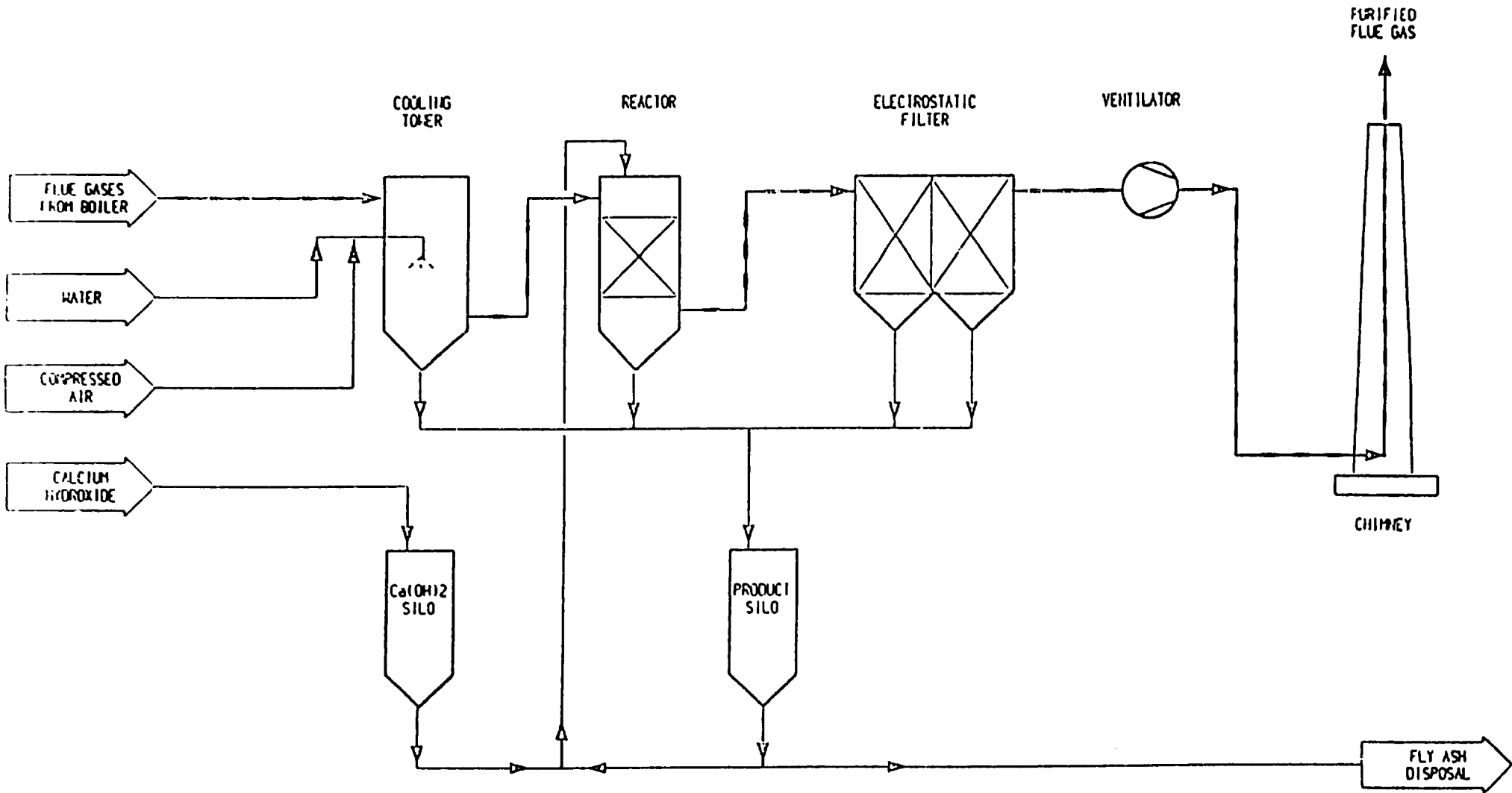

BASIC FLOW DIAGRAMM
FLUE GAS CLEANING SYSTEM

TAB. 8

LEGENDA

I LINE 150 t/d

- 1) Conveyor belt 1.200x25.000
- 2) Iron slide
- 3) Conveyor Belt 1.000x20.000
- 4) Vibrating screen 2.000x7.000
- 5) Ballistic separator 500x7.000
- 6) Conveyor belt compost 1.000x11.000
- 7) Conveyor belt compost 1.000x11.000
- 8) Conveyor belt compost 1.000x 9.000
- 9) Roller pulverizer
- 10) Conveyor belt compost 1.000x 6.000
- 11) Conveyor belt compost 1.000x 9.000
- 12) Conveyor belt compost 1.200x30.000
- 13) Conveyor belt rejects 1.000x12.000
- 14) Conveyor belt rejects 1.000x 6.000
- 15) Conveyor belt rejects 1.200x12.000
- 16) Conveyor belt rejects 1.200x30.000
- 17) Magnetic separator
- 18) Conveyor belt for ferrous materials

- n° 2
- n° 2
- n° 4
- n° 4
- n° 4
- n° 4
- n° 4
- n° 4
- n° 4
- n° 4
- n° 4
- n° 2
- n° 4
- n° 4
- n° 4
- n° 2
- n° 4
- n° 4

TOTAL MACHINARIES FOR 2 LINES OF 150 t/d

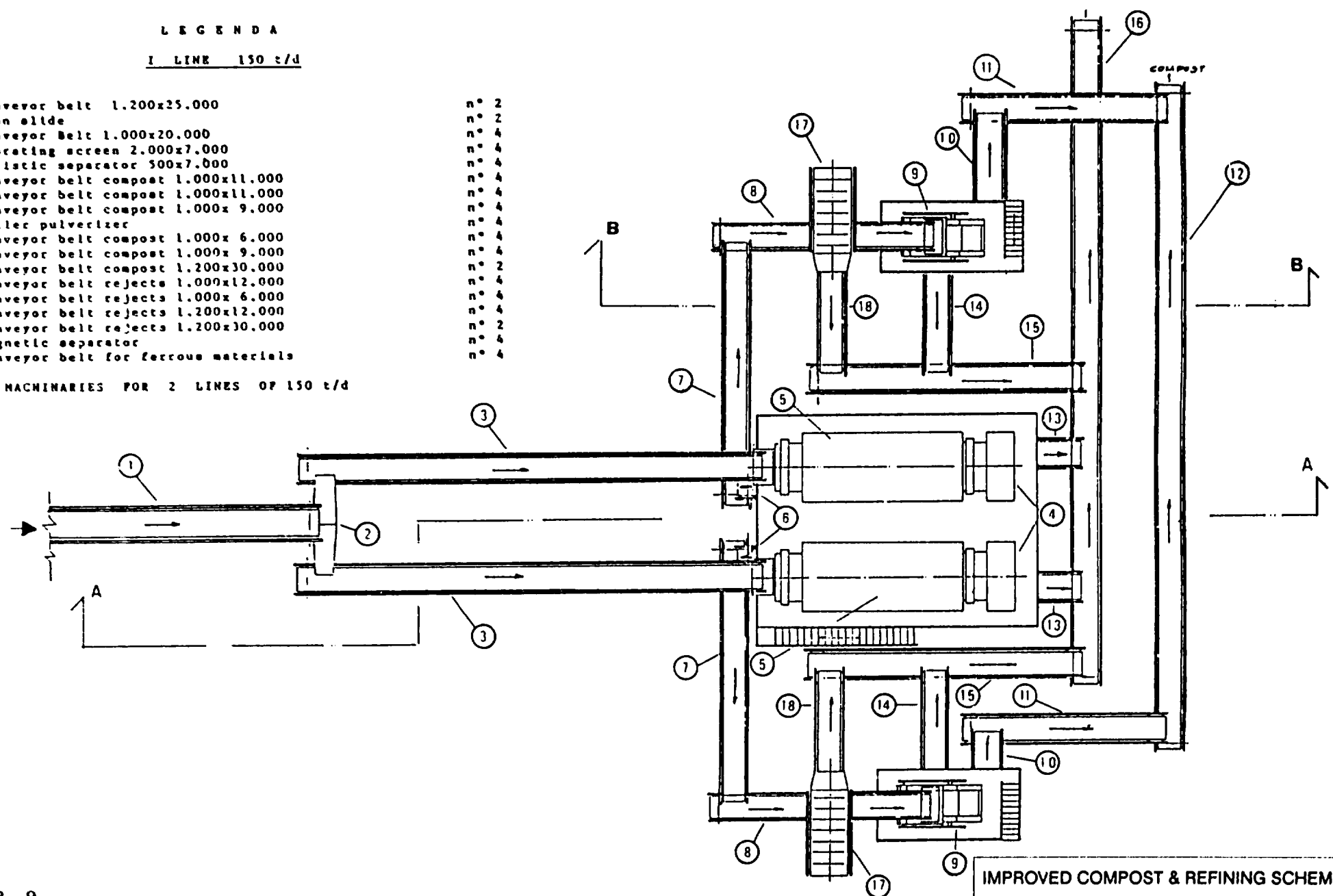

IMPROVED COMPOST & REFINING SCHEME

7. ECONOMIC EVALUATION AND ANALYSIS OF THE SUGGESTED SCENARIOS

A preliminary design of the revamped plants, according to the proposed scenarios, has been carried out. It was necessary to obtain the estimated new performances of each scenario (see technical features of the plants A - B).

The design has been made according to the following considerations:

- Waste heat recovery unit

It has been assumed to produce superheated steam at 40 bar and 400 grade C by means of a well known boiler technology. The outlet pressure placed after the turbine, 0.45 ata will facilitate the condensation of steam by air cooler.

- Flue gas dry cleaning unit

The unit has been designed to obtain emission level values to comply with current pollution control regulations (see para. 2)

- Compost/refinery line

It has been designed according to current guidelines of compost production.

- Transfer loading station

6 (six) compacting trucks and 3 (three) bulldozers were assumed for each station.

The economic evaluation, based on the preliminary design and european standard costs, has been carried out according to budget quotations and/or assumptions based on our experience (see estimated capital investment statement). In particular, we would like to point out the following:

- Operation labour

Expatriate plant manager and local manpower were assumed for the management of the plant. The local personnel could undergo the necessary training during the revamping of the plants. Estimated personnel for running CLAUDIUS PETERS / MARINI plants is 50, for running transfer loading station is 6.

- Actual value of the revamped plants

We assumed a specific capital investment of 3.92 million USD/ton of waste processed per hour (installed incineration capacity) (Ref.4). In addition, the capital investment for composting/refining line and transfer loading station was considered.

- Maintenance

For solutions "A" and "B" we did not take into account the spare parts recovered from the other plants.

- Overheads

We assumed 50% of labour cost (Ref. 5).

- Income from sales of electric power

We assumed 65% of power cost to the grid of local utility, and, in particular, 0.037 USD/KWH.

- Income from sale of produced compost

Due to the high demand of imported chemical fertilizer the market of compost in Nigeria could be of certain interest and we believe that from its sale a reasonable income can be obtained.

According to the european market, compost cost depends on the local situation and usually it is not easy to obtain a reasonable value. We assumed a very conservative value of 0.105 USD/ton.

- Sanitary Landfills

In the Capital Investment Statement rehabilitation or realization costs for the landfills foreseen in the suggested scenarios have not been considered.

In scenario C due to the lack of incinerator plant, and consequently an increase of quantity of waste to be treated additional Capital investment should be considered.

TECHNICAL FEATURES OF THE PLANTS

A) ACTUAL

	"CLAUDIUS PETERS"	MARINI
M.S.W. Capacity (each line) t/h:	8	5
Combustion temperature nor/max C	900	900/1200
L.H.V. of M.S.W. (assumed) KCal/kg	2,200	1,200
Flue gas Flow rate (after incinerator) Ncm/h	47,200	36,000 *
Flue gas Flow rate (after cooling system) Ncm/h	126,600	56,000
- Consumption		
El. power KW	500 *	600 *
Fuel Oil drying (average) kg/h	275	--
incineration kg/h	--	246 *
Fresh water scrubber cm/h	3	3
incineration cm/h	--	--
- By product		
Ash and inerts kg/h	2,000 *	1,250 *

* Assumed figures

B) AFTER REVAMPING

		"CLAUDIUS PETERS"	MARINI
M.S.W. Capacity (each line) t/h:		8	5
Combustion temperature nor/max C		900	900/1200
L.H.V. of M.S.W. (assumed) KCal/kg		2,200	1,200
Flue gas Flow rate (after incinerator) Ncm/h		47,200	36,000 *
Flue gas temperature after boiler C		250	250
Flue gas temperature before stack C		120	120
Flue gas Flow rate before stack	Ncm/h kg/h	50,960 63,700	38,265 (47,830)
- Consumption			
El. Power	KW	500	600
Fuel oil	drying (avg) kg/h incineration kg/h	192 --	-- 160
Fresh water	scrubber cm/h conditioning tower cm/h	3 3.5	2.7
Ca(OH)2	reactor kg/h	55	44
Compressed air	kg/h	348	265
- By product			
Total ash	kg/h	183	140
Inerts			
Products			
Produced steam (at 400 C and 40 bar)	t/h	16.5	12.5
Generated power (r= 8 kg of vapour/kW)	kW	2,000	1,560
Exported power	kW	1,500	960

ESTIMATED CAPITAL INVESTMENT STATEMENT

	U.S.\$ x 1000		
	Proposed scenario		
	A	B	C
REVAMPING OF PLANTS			
Mechanical components	1,017	1,322	-
Motors and electrical appliances	322	262	-
Instrumentation and controls	215	287	-
Electric generating units	98	609	-
	-----	-----	-----
TOTAL	1,652	2,480	
 ADDITIONAL TECHNOLOGIES			
Waste heat recovery unit (Tab.6)	6,200	5,300	-
Flue gas cleaning system (Tab.7)	5,200	4,300	-
Compost refining line (Tab.9)	3,800	3,800	4,300
Transfer loading station	1,148	1,148	2,296
Working capital cost for start-up (5% of fixed capital cost)	800	700	300
	-----	-----	-----
TOTAL	17,148	15,248	6,896
 ESTIMATED CAPITAL INVESTMENT	 18,800	 17,728	 6,896
	-----	-----	-----
 Estimated value of the revamped plants including additional up dated technologies	 67,700	 44,150	 6,896
	-----	-----	-----

OPERATING COST
(based on 7800 working hour/year)

U.S.\$ x 1000

Proposed scenario

	A	B	C
MAINTENANCE			
Incinerating plant	0.26	0.35	-
Transfer loading station	0.01	0.01	0.02
Compost refining line	0.19	0.19	0.19
	----	----	----
	0.46	0.55	0.21
 LABOUR COST			
Incineration plant	0.17	0.16	-
Transfer loading station	0.01	0.01	0.02
Compost refining line	0.04	0.04	0.04
	----	----	----
	0.22	0.21	0.06
 OVERHEADS			
Incineration plant	0.04	0.04	-
Transfer loading station	n.s.	n.s.	n.s.
Compost refining line	0.01	0.01	0.01
	----	----	----
	0.05	0.05	0.01
 RAW MATERIALS AND UTILITIES			
Fuel oil (0.08 U.S.\$/kg)	0.12	0.10	0.01
Ca (OH) ₂ (0.081 U.S.\$/kg)	0.03	0.03	-
Ash and inerts disposal ((0.021 U.S.\$/kg)	0.03	0.03	-
	----	----	----
	0.18	0.16	0.01
TOTAL OPERATING COST	0.91	0.97	0.29
	=====	=====	=====
 INCOME FROM SALES OF PRODUCTS			
Electric power	0.87	0.58	-
Compost	0.23	0.23	0.23
	----	----	----
TOTAL INCOME	1.10	0.81	0.23
	=====	=====	=====
NETT OPERATING PROFIT/LOSS	+0.19	-0.16	-0.06
	=====	=====	=====

8. REFERENCES

- (1) Washburn S.T., Brainerol J., and Harms R.H. -
Environmental impact assessment review - Vol.9, n.3
Sept. 89
- (2) The journal of the Air and Waste Management
Association by Sommer et al. (April 89)
- (3) Lago A. - Impiantistica italiana - April 90
- (4) Barniske L.: "Environmental impact assessment
review" - Vol. 9 - No. 3 - Sept. 89.
- (5) Peters M.S. and Timmerhaus K.D.: "Plant design and
economics for chemical engineers" Ed. Mc. Graw-Hill
- 9th printing 1988.