



TOGETHER
for a sustainable future

OCCASION

This publication has been made available to the public on the occasion of the 50th anniversary of the United Nations Industrial Development Organisation.



TOGETHER
for a sustainable future

DISCLAIMER

This document has been produced without formal United Nations editing. The designations employed and the presentation of the material in this document do not imply the expression of any opinion whatsoever on the part of the Secretariat of the United Nations Industrial Development Organization (UNIDO) concerning the legal status of any country, territory, city or area or of its authorities, or concerning the delimitation of its frontiers or boundaries, or its economic system or degree of development. Designations such as “developed”, “industrialized” and “developing” are intended for statistical convenience and do not necessarily express a judgment about the stage reached by a particular country or area in the development process. Mention of firm names or commercial products does not constitute an endorsement by UNIDO.

FAIR USE POLICY

Any part of this publication may be quoted and referenced for educational and research purposes without additional permission from UNIDO. However, those who make use of quoting and referencing this publication are requested to follow the Fair Use Policy of giving due credit to UNIDO.

CONTACT

Please contact publications@unido.org for further information concerning UNIDO publications.

For more information about UNIDO, please visit us at www.unido.org

19221

Distr.
RESTRICTED

UNITED NATIONS
INDUSTRIAL DEVELOPMENT ORGANIZATION

IO/R.217
24 October 1991

ORIGINAL : ENGLISH

72 p.
tables
graphs
diagrams

ASSISTANCE IN THE ESTABLISHMENT OF A
PILOT LUMBER KILN DRYING PLANT

XP/SAM/90/015

THE INDEPENDENT STATE OF WESTERN SAMOA

Terminal Report*

Prepared for the Government of the Independent State of Western Samoa
by the United Nations Industrial Development Organization.

Based on the work of A.M. McNaught,
Timber Drying Consultant

Backstopping Officer: Antoine V. Bassili
Agro-based Industries Branch

United Nations Industrial Development Organization

Vienna

* This report has not been edited.

V.91-29999

CONTENTS

Explanatory Notes	4
Abstract	5
Acknowledgements	6
INTRODUCTION	7
I WOOD DRYING IN THE TIMBER INDUSTRIES	8
A. Kiln Seasoning	8
B. Air Drying	8
C. General	8
II WOOD DRYING IN THE WESTERN SAMOAN CLIMATE	9
III DRYING REQUIREMENTS OF THE TIMBER INDUSTRIES	9
IV STATUS OF COCONUT WOOD PRODUCTS Ltd.	10
V DESCRIPTION OF KILN TYPES	11
A. Conventional Compartment Kilns	11
B. Dehumidifier Kilns	12
C. Solar Kilns	15
D. Screen Kilns	16
E. Predryers	18
F. Progressive Kilns	19
G. Vacuum Kilns	21
H. Radio Frequency (RF) Kilns	22
I. Press (Platen) Drying	22
J. Chemical (Azeotropic) Seasoning	22
VI RECOMMENDED KILN TYPE FOR INDUSTRY	22
A. Recommended kiln type for a coconut sawmill	24
B. Recommended kiln type for furniture manufacturers	25
VII INFRASTRUCTURE REQUIRED FOR MULTI-USER DRYING FACILITY	25
A. Drying Facility - Organisational Structure and Operation	26
VIII FUTURE CHANGES TO THE TIMBER RESOURCE	27
A. Indigenous Species	27
B. Plantation Species	27
C. Impact on Wood Drying Requirements	28
IX CONCLUSIONS AND RECOMMENDATIONS	28
A. Conclusions	28
B. Recommendations	30
References or Documents Consulted	32
TABLES	27
1. Summary of climatic data for Apia weather station	9
2. Drying requirements of the timber industry	10
FIGURES	
1. Schematic view of indirectly heated compartment kiln.	12
2. Schematic view of a dehumidifier kiln.	14
3. Plan view of a screen kiln.	17
4. Sectional elevation of a six line predryer.	18
5. Schematic plan of a progressive kiln.	20
6. Decline of merchantable sawlog volumes in the indigenous forests of Savaii.	27

APPENDICES

1.	Job Description	33
2.	People consulted in the course of the mission	36
3.	Coconut Wood Products Ltd. tender document	37
4.	Drying costs for conventional. solar. screen and dehumidifier kilns	41
5.	Building notes for the solar kiln	44
6.	Duties of expert for solar kiln installation & training	71
7.	Comments by the Substantive Officer	72

Explanatory Notes

The value of the local currency during the period of this consultancy was WS \$2.23 = US \$1.00 (UN Operational rate of exchange).

Electricity cost is a flat rate for all consumers and is WS \$0.32/kWhr.

The following abbreviations have been used in this report:

UNIDO	United Nations Industrial Development Organization
WS	Western Samoa
CWPL	Coconut Wood Products Limited
WSTEC	Western Samoa Trust Estates Corporation
DBWS	Development Bank of Western Samoa
e.m.c.	equilibrium moisture content
SFP	Samoa Forest Products Ltd.
RH	Relative Humidity
RF	Radio Frequency
DED	Department of Economic Development
m ³	cubic metres

Abstract

This study was originally intended to finalise the specification for kilns to be installed at Coconut Wood Products Limited (CwPL) at Vaitele, Western Samoa. Shortly before the commencement of the mission, CwPL ceased operations after four years of unprofitable trading. The government shareholders have been attempting to privatise the company, but negotiations with the "successful" tenderer have broken down. It is considered unlikely that CwPL will be sold because of lack of guaranteed log supply, the size of its accumulated debt, the re-leasing of part of the site to two other businesses and the recent fire in the treatment plant building.

However, the study did find that coconut wood processing is likely to become an important part of the sawmilling industry in Western Samoa. This will probably occur from the year 2000, when the resource of indigenous hardwood forest is exhausted (given current cutting rates). Although hardwoods are being planted, these will be unable to supply demand until approximately 2010.

Kiln drying of timber is needed if the local furniture manufacturers are to maintain their markets. Because of the high cost of electricity and insufficient wood residues produced by these manufacturers, greenhouse type solar kilns are recommended for this industry. The climate of the coastal fringe in and around Apia is ideal for solar drying.

The infrastructure necessary for a co-operative solar drying facility is described and two suitable sites for the operation were investigated. Plans for the construction of kilns are provided.

Acknowledgements

The consultant is indebted to the many people in Western Samoa who were so helpful in the provision of information and advice. Several in particular deserve special mention: Mrs. Fu'a Hazelman of UNDP; Mr. Misiolo Sofe, Samuelu Enari and Mrs. Itagia Faumui of the Department of Economic Development and Mr. Tapa Suaesi of the Forestry Division. The assistance and friendship of these people made it possible to achieve a great deal in a short time.

The consultant is grateful also to Mr. Graeme Palmer and Mr. David Cough of the Queensland Forest Service for the drawing of plans and the specifications of the solar kilns.

INTRODUCTION

This report covers a consultancy by A.M. McNaught, consultant in timber drying conducted over two weeks in September 1990. A copy of the job description is contained in Appendix 1. It follows up an exploratory mission by UNIDO consultant, H.P. Brion, who provided assistance to the furniture industry of Western Samoa in January, 1988. (Project DP/RAS/86/075). He concluded that the wood-based furniture industry was severely handicapped by the non-availability of properly seasoned local timber, and that the higher cost of imported dried timber would increase prices of furniture and joinery products excessively for local consumption. Furthermore, the local resource of coconut wood cut from overmature plantations managed by the Western Samoa Trust Estates Corporation (WSTEC) was not being utilised for value added products and expansion of the uses of coconut wood was required to assist the implementation of the coconut replanting programme. Brion considered that the construction of wood waste fired flue-gas heated kilns at Coconut Wood Products Limited (CWPL) to dry both coconut timber and indigenous hardwood would assist furniture manufacturers and increase the use of coconut wood.

The main objectives of this mission were to:

1. Determine the required kiln capacity of CWPL;
2. Confirm that the choice of a wood waste fired flue-gas heated kiln is the most appropriate kiln type for CWPL;
3. Draw up technical specifications for the proposed kilns and laboratory equipment;
4. Define the duties of local and expatriate personnel required to build these kilns.

These objectives required revision because CWPL has ceased operation following four years of unprofitable trading. The shareholders, WSTEC and the Development Bank of Western Samoa (DBWS) attempted to sell the company by tender in January 1990. Although a tenderer was advised that his offer was successful, negotiations appear to have broken down, principally because WSTEC is unable to guarantee log supply. It would seem unlikely that CWPL will start operating in the near future.

Accordingly, the mission was modified. The need for properly dried timber by furniture manufacturers is still as great as when Brion reported on its status in 1988. The strong demand for timber following cyclone Ofa in February 1990 has meant that timber producers have little interest in supplying correctly seasoned timber, as sales for green timber are assured. A suitable kiln type for furniture manufacturers was therefore investigated, as were possible sites and the infrastructure for such a drying facility. The kiln drying needs for the coconut timber industry are still relevant for the future, as there will be a ten year period from the year 2000 when the lack of indigenous timber resource is likely to make coconut wood processing a necessity. After 2011, the plantation hardwood programme should be able to supply demand.

The list of persons met is given in Appendix 2.

I. WOOD DRYING IN THE TIMBER INDUSTRIES

Wood drying to appropriate moisture contents to prevent shrinkage is not common in the timber industries. Most timber is sold either green off saw or after some limited kiln or air drying. The purchasers of timber destined for appearance grade products, such as furniture and joinery, generally attempt to air dry their timber to around 18-20 percent moisture content, although this is often not achieved.

A. Kiln Seasoning

Samoan Forest Products Limited (S.F.P.) at Asau, Savaii, operates the only conventional steam heated compartment kilns in the country. The kilns are aluminium sandwich panel construction, with conventional finned heat exchangers, line shaft fans and humidification by open steam lines. The manufacturer of these kilns is Moore kilns of Canada. There are five kilns, each with a nominal capacity of 100 m³. Only three of the five are operational - the other two have been used for spare parts and are damaged. The remaining 300 m³ capacity is more than adequate for the budgeted sawmill output of 12000 m³/year, as 25 mm thick timber is only dried to 20 percent m.c. and 50 mm thick timber is dried to between 30 percent and 50 percent m.c.

Two other sawmills in Savaii, T.V. Corporation and Bluebird Sawmill, both have considered the installation of kilns, but regard conventional kilns as too expensive for the size of their sawmills. Each has approximately 1000 to 1200 m³/year of timber which they would like to dry. Another mill, New Samoa Wood Industries at Vaitele, Upolu, also has drying needs of about 1200 m³/year.

B. Air Drying

No air drying was observed in any of the sawmills visited.

On building sites, timber for structural purposes is often stacked vertically against trees or makeshift supports. Such practice will reduce the moisture content somewhat, but results in surface checking and distortion caused by uneven drying of one side compared to the other.

Furniture manufacturers are correctly dubious about claims that timber supplied to them is seasoned unless it is imported. Most air dry their timber in undercover racks, with layers separated by stickers, for about two months for 25 mm thick boards. The standard of air drying was reasonable, with attention paid to sticker alignment and protection from the sun and rain. However, most air drying sheds have poor air circulation, as they are surrounded by other buildings and trees. Whilst few drying defects occur under these circumstances, drying rates are much lower than what can be achieved in a well designed air drying yard.

C. General

There is a good understanding by furniture manufacturers of the need to dry timber to a moisture content appropriate to the location of its end use. Most know of the lower e.m.c. in air conditioned environments, however none of the furniture or joinery manufacturers or any of the timber suppliers have equipment for moisture content determination by the oven dry method and only

one sawmill (SFP) has a moisture meter. No species or temperature correction factors are used with this meter, and no species correction factors are available locally. Although figures published in Australia, New Zealand and Fiji are available for the most common species used, these should be used with caution, as large variations in electrical conductivity can occur for a particular species from different localities and countries (Hartley and Marchant, 1988).

The understanding of the local timber industries about types of kilns is poor, with most knowing only about conventional steam heated compartment kilns and dehumidifier kilns.

II. WOOD DRYING IN THE WESTERN SAMOAN CLIMATE

Table 1 summarises the climatic data for Apia. The climate for air drying is particularly good with an average temperature of 28°C, average relative humidity of 79 percent and generally strong trade winds. Surface checking is not common, due to the generally high and constant relative humidity.

Table 1 Summary of climatic data for Apia weather station. Figures are mean normals for the years from 1941 to 1987 inclusive.

	Jan.	Feb.	Mar.	Apr.	May	Jun.	Jul.	Aug.	Sep.	Oct.	Nov.	Dec.	Annual
Temp °C	28.0	27.8	27.8	28.0	27.7	27.8	27.0	27.0	27.5	27.7	28.1	28.0	27.7
R.H. %	81	82	81	81	79	78	77	77	78	79	79	81	79
hours sun	176	158	187	182	209	208	223	226	226	208	285	274	2582

Forestry Division data show that the outdoor e.m.c. is 17 percent. The inside e.m.c. could be expected to be 15-16 percent in normally ventilated rooms, since inside e.m.c. is typically 1-2 percent lower (Bragg, 1986). In air conditioned rooms and offices, of which there are many in Apia, an e.m.c. of between 10 and 13 percent would apply, depending on the air exchange rate of the air conditioner and the size of the conditioned space.

It is clear from the above figures that significant shrinkage will occur with the use of any timber that has not been kiln dried, since even well air dried timber will only reach 18 percent moisture content. Because virtually all new office developments are air conditioned, local furniture manufacturers must use properly kiln dried timber if their products are to be used in these buildings.

III. DRYING REQUIREMENTS OF THE TIMBER INDUSTRIES

The drying requirements of the furniture, joinery, building and sawmilling industries are tabulated (Table 2). Figures given for the sawmills are the volumes which their managers consider they would dry given adequate kiln facilities.

Table 2. Drying requirements of the timber industries.

COMPANY	OPERATION TYPE	DRYING REQUIREMENTS
(a) Furniture, joinery and building		
S Young Construction	Furniture, building, joinery	100 m ³ of 25 mm 45 m ³ of 50 mm
Lober Industries	Furniture, building, joinery	200 m ³ of 25 mm small amounts of 50 mm
GMA Construction	Furniture, building, joinery	50 m ³ of 25 mm (furniture) 200 m ³ of 50 mm (building)
Pat Ah Hin Co.	Furniture, joinery	25 m ³ of 25 mm
Milford Development	Furniture, joinery	20 m ³ of 25 mm
Saleufi joinery	Joinery	400 m ³ of 25 mm 20 m ³ of 38 mm and thicker
Laufiso Taro Wengling	Furniture	60 m ³ of 25 mm
Total 1300 m³ - approx 850 m³ of 25 mm 450 m³ of thicker timber		
(b) Sawmills without kilns		
T V Corporation	Sawmilling	1200 m ³ of 25 mm
New Samoa Wood Ind.	Sawmilling	1200 m ³ of 25 mm
Bluebird Limited	Sawmilling	1000 m ³ of 25 mm
Savast Sawmills	Sawmilling	Not known
Total 3400 m³ of 25 mm		
(c) Sawmills with kilns		
Samoa Forest Products	Sawmilling	5000 m ³ of 25 mm Some 50 mm also
Total 5000 m³ of 25 mm		
(d) Proposed developments		
Quality frames and trusses	Building	1000 m ³ of 50 mm
Total 1000 m³ of 50 mm		

For the seven furniture manufacturers surveyed in Apia, the total dried timber required is 1300 m³ per year, made up of 850 m³ of 25 mm and 450 m³ of 50 mm. At present, approximately 600 m³ is imported, mostly from Fiji and New Zealand.

IV. STATUS OF COCONUT WOOD PRODUCTS Ltd.

When Mr. Brion examined the furniture industry of W. Samoa in 1988, he recognised the need for a timber drying facility to enable the furniture manufacturers to maintain the market for their products. He considered that CWPL was the most suitable organisation to conduct drying, both for coconut wood and the indigenous hardwoods.

CWPL commenced operation in 1976 as a result of New Zealand financial and technical assistance. Its ownership and management has changed hands four

times and it has ceased operations in 1981 and between 1982 and 1985. At present CWPL is a joint venture company owned by WSTEC and DEWS. In January 1990, these shareholders attempted to sell the company by open tender (see Appendix 3). One tenderer, Lober Industries Ltd., was advised by DEWS that their tender was successful, however finalisation of the sales has not been completed because:

1. WSTEC will not provide guarantees of a continuing log supply, despite statements to the contrary in the tender document.
2. WSTEC consider that the price offered by the tenderer is too low to recover sufficient of the accumulated debt.
3. The lease on the 4 acres on which CWPL is situated would no longer appear to be valid, since two 0.5 acre leases have been drawn up on the same area. This is despite the expiry date of 2004 on the original lease, although CWPL may have breached this original lease through non-payment of annual rental.

Lober Industries Ltd. bid for CWPL was conditional on items 1 and 3 being resolved. Whilst the land leasing arrangements could be negotiated, the lack of guarantees on log supply would be more difficult to resolve. WSTEC is at present changing its structure and the ownership of much of its plantations, so it is clearly not in a position to enter into any guarantees. WSTEC also consider that the target replanting of senile plantations of 1000 acres per year may not be achieved because of financial constraints. At this stage, WSTEC and Lober Industries are communicating through their respective solicitors. The principal of Lober Industries, Joe Lober, considers it extremely unlikely that the contentions issues can be resolved.

More difficulties have occurred with the venture because a fire has destroyed part of the treatment cylinder equipment and the shed in which the treatment tanks are contained.

It is therefore considered unlikely that CWPL will operate in the near future. It is the consultant's opinion that the utilisation of coconut wood will probably be limited to treated posts and poles until timber shortages in the early 2000's impact. (see Chapter VIII)

V. DESCRIPTION OF KILN TYPES

A wide range of kiln types have developed in response to different drying requirements, energy sources and scale of operation. This chapter describes the range available and their attributes. Examples provided on capital cost refer to installed costs in Western Samoa, excluding import duties.

A. Conventional Compartment Kilns

Figure 1 shows the essential elements of a conventional compartment kiln. These kilns may be constructed from any heat and moisture resistant material, such as clay bricks, concrete blocks, reinforced concrete, insulated metal panels and even fibre-cement sheet on a timber frame. Where energy cost is high, or when operating temperatures are very much higher than ambient conditions, the materials used must provide good insulation. Most kilns of this type are constructed now from modular insulated aluminium panels using a steel portal frame, although masonry construction is popular where capital cost needs to be minimised.

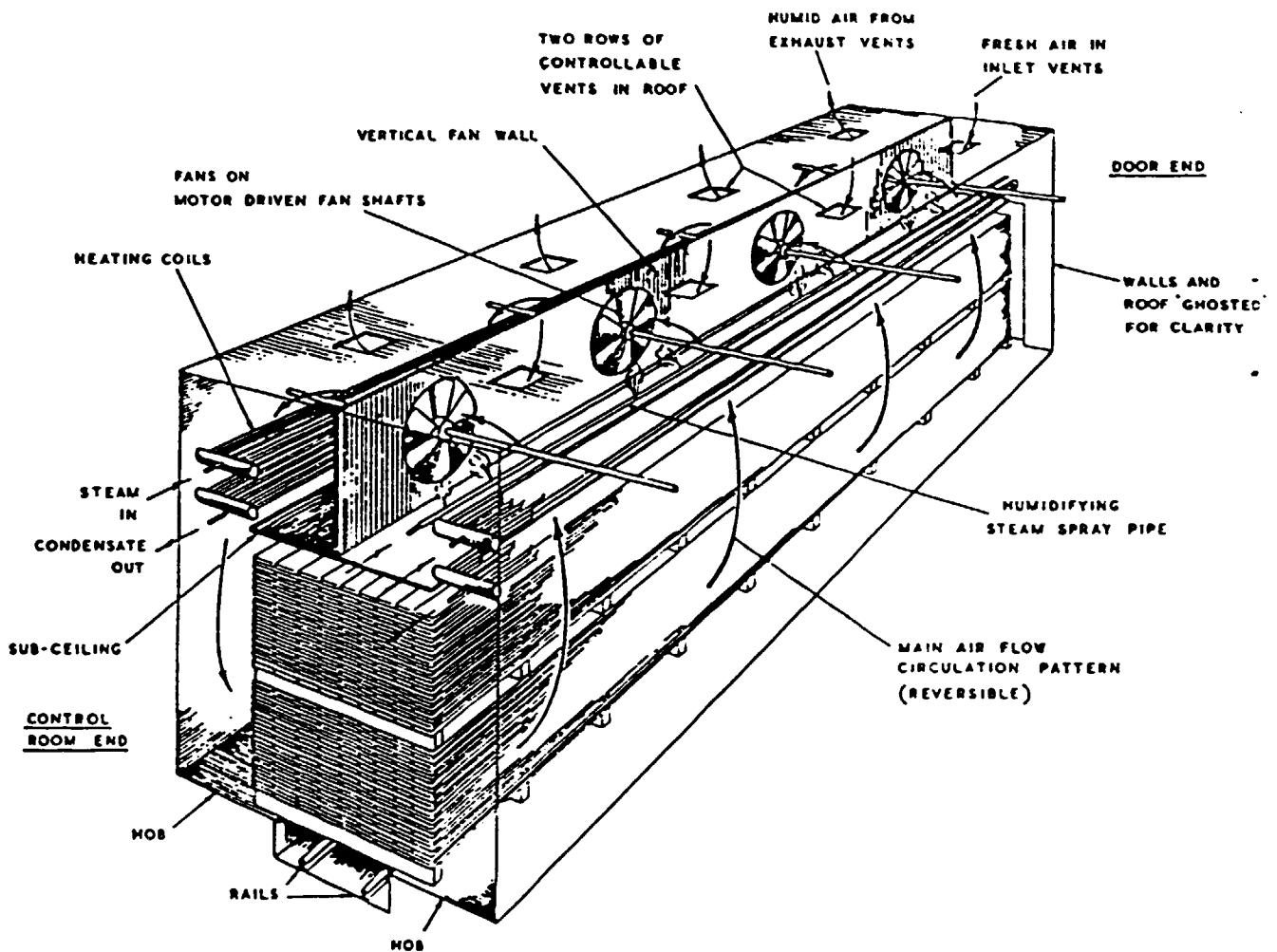

Fig. 1: Schematic view of an indirectly heated compartment kiln showing the main features.

Operating temperatures of these kilns can range from 35°C in the case of drying refractory, collapse prone species from high moisture contents, to 150°C for the rapid drying of coniferous species.

The main features of this type of kiln are the air circulation fans, steam lines or water spray nozzles for humidification, vents for dehumidification and the heat source. The heat source can vary greatly, and kilns can be classified as either indirectly heated or directly heated.

Indirectly heated kilns use some form of heat exchanger to heat the circulating air within the kiln. This is almost always a series of finned tubes through which steam, high temperature oil, hot water or the gases from combustion are circulated.

Directly heated kilns do not have heat exchangers. The products of combustion are circulated throughout the kiln and then are vented to the atmosphere. Because of the danger of the timber in a direct fired kiln catching fire, the design and maintenance of these systems is critical to their success. At present, only gas direct fired kilns have proved

satisfactory as the sparks from wood waste fired system are a major problem. Spark arrestor equipment of the standard required to prevent any sparks entering the kiln chamber is currently more expensive than a comparable heat exchanger system.

The main attributes of conventional compartment kilns are:

1. Capacity - 5 m³ to over 200 m³
2. Energy Sources - Indirect:
 - wood waste, gas or oil heating steam
 - wood waste, gas or oil heating water
 - wood waste, gas or oil heating oil
 - wood waste combustion gases
 - gas combustion gases.
 Direct:
 - gas combustion
 - wood waste combustion (not recommended)
 - oil combustion.
3. Capital cost examples (installed costs):
 - (a) 1 x 15 m³ masonry kiln, indirectly heated with a wood waste fired hot water boiler.

kiln	US \$20,000
boiler	US \$30,000
handling equipment	US \$15,000
Total US \$65,000	
 - (b) 2 x 60 m³ aluminium panel kiln, indirectly heated with a wood waste fired steam boiler.

kilns	US \$750,000
boiler	US \$500,000
handling equipment	US \$100,000
Total US\$1350,000	
4. Labour - assumes continuous boiler attendance is required
 - (a) 1 x 15 m³ kiln : 7 days/week x 24 hours/day x 2 people
 - (b) 2 x 60 m³ kilns: 7 days/week x 24 hours/day x 3 people
(does not include timber stacking)
5. Drying Times (estimated)

At 70-80°C Dry bulb temperature, with medium density tropical hardwoods (eg. tava, approx 700 kg/m³ at 12 percent). 3 days from 25 percent to 12 percent moisture content for 25 mm thick timber.

B. Dehumidifier kilns

Figure 2 shows the essential elements of a dehumidifier kiln. The main features of dehumidifier kilns that distinguish them from conventional compartment kilns are that they are nearly always electrically heated and that water evaporated from the wood is removed from the kiln by condensation, thereby recovering the latent heat of vaporisation.

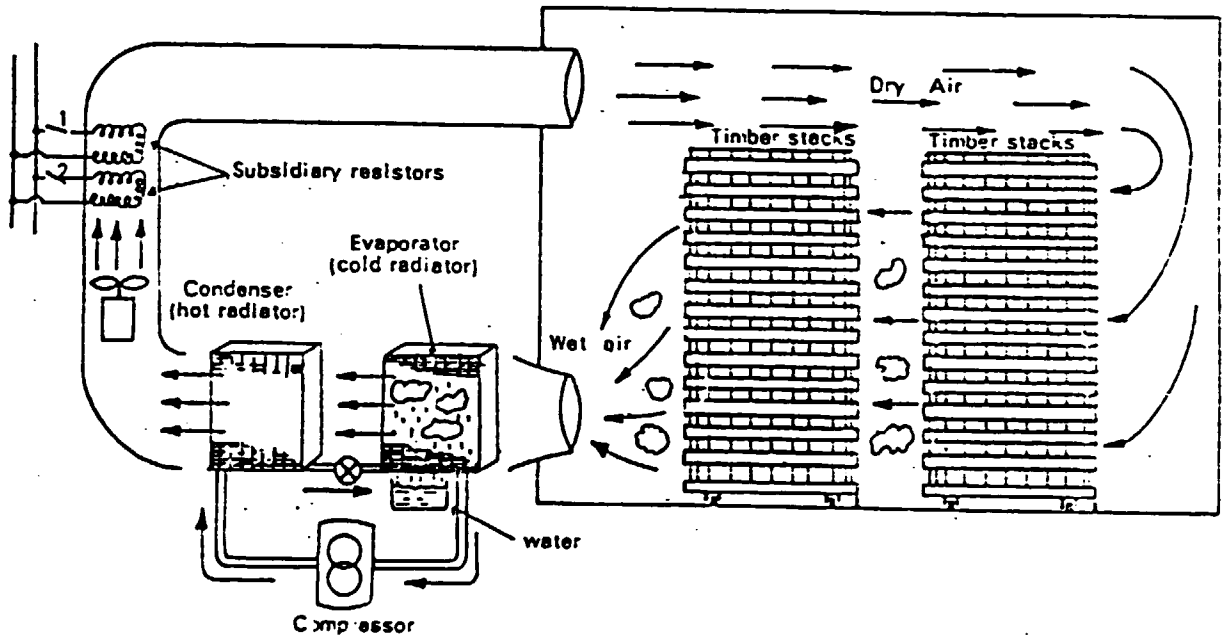

Fig 2.

Schematic view of a dehumidifier kiln. Dry air is blown over the top of the charge and flows back through the timber and over the evaporation coils of the refrigeration unit. The evaporator coils chill the air, thereby condensing water and recovering the latent heat of vaporization. The condensate is drained from the unit to the outside of the kiln. The air then passes over the condenser coils where it is heated before circulating through the timber again. In most of these kilns, subsidiary resistance heating is provided to speed heat up, and in many designs, additional air circulation is provided by auxiliary fans.

Because the energy source is expensive, the kilns are generally constructed from metal-foam-metal panels, similar to those used in commercial cool rooms.

Limitations on the maximum operating temperature of the refrigerant limit kiln temperatures to around 60°C. Drying is therefore somewhat slower than for conventional kilns. In addition, dehumidifier kilns do not have any steam humidification system, so kiln operators cannot steam collapse-prone timbers and it is difficult to minimise moisture gradients throughout timber cross-section. However, the lower drying rate usually means that drying stresses do not develop to the same degree as conventional kilns, so quality of drying overall is good.

Dehumidifier kilns are generally suitable for small to medium sized operations (less than 2000 m³/year) where electricity costs are low. Some manufacturers are experimenting with diesel powered refrigeration systems where the engine and exhaust heat is recovered in the kiln. however this, at present, is not commercially available.

Commercial dehumidifier kilns vary in size from 5 m³ to 250 m³. Larger kilns use approximately the same amount of electricity per m³ to run as small kilns, as compressor and fan sizes are scaled proportionally to timber volume.

The main attributes of dehumidifier kilns are:

1. Capacity - 5 m³ to 250 m³
2. Energy Sources - electricity.
- diesel (still experimental)
3. Capital Cost examples (installed costs)
 - (a) 1 x 20 m³ US \$45,000
 - (b) 1 x 60 m³ US \$90,000
 (These costs do not include a forklift for loading)
4. Labour (does not include timber stacking)
 - 1 x 20 m³ 5 days/week x 8 hours/day x 1 person
 - 1 x 60 m³ 5 days/week x 8 hours/day x 1 person
5. Drying Times (estimated)

At 60°C, 25 mm thick tava will dry in 4-5 days from 25 percent to 12 percent moisture content.

C. Solar kilns

Solar kilns rely on solar radiation to provide heat for drying. There are basically two types of solar kilns. Direct gain kilns are a single glazed structure that contains the timber and heat absorbing surfaces in the same chamber. Indirect gain kilns consist of a well insulated kiln with a separate heat collector. Hot air or hot water is circulated from the collector to the kiln. Direct gain kilns are more popular because of their low capital cost, simplicity of construction and very low maintenance costs.

Solar kilns can be constructed using a wood or metal frame glazed with a variety of materials - glass, polythene sheet, Melinex, fibre reinforced plastic and polycarbonate are popular. The recent availability of corrugated, U.V. stabilised, polycarbonate at reasonable prices has reduced the problem of glazing degradation. The manufacturers of this product (Suntuff) - anticipate a life in tropical climate of at least 10 years and guarantee the product for 7 years against discolouration.

There are numerous designs of direct gain solar kilns throughout the world. The proven designs operate at temperatures of 50-55°C during the day in tropical climates, with peak temperatures as high as 65°C. Performance is generally governed by how airtight the structure is and the area of roof glazing in relation to the volume of wood in the kiln.

Drying in solar kilns is about 2-3 times slower than conventional kilns operating at 80°C, however the slow drying results in negligible drying stress

and very low levels of drying degrade. This can also be attributed to humidity cycling that occurs from day to night in the kiln, as this cycling increases the amount of stress relaxation because of high levels of mechano-sorptive creep.

The main attributes of solar kilns are:

1. Capacity. 2 m³ to 20 m³ for direct gain types, although 15 m³ is recognised as the maximum efficient practical size.
2. Energy Source. Solar energy and a small amount of electrical energy for fan operation.
3. Capital Cost examples. (installed costs)
15 m³ direct gain kiln US \$8-10,000
4. Labour. (does not include timber stacking).
Intermittent attendance only is required to check on moisture content status and to load/unload kiln. Allow 5 days/week x 4 hours/day x 1 person.
5. Drying Times. (estimated)
25 mm thick tava will dry in 6-9 days from 25 percent to 12 percent moisture content given average sunshine level of 2500 hours/year.

D. Screen kilns

Screen kilns are really a variation of the conventional compartment kiln designed to reduce the cost of fans and motors (see Figure 3). Only one fan and motor is used and screens are used to give uniform air flow along the length of the charge. These kilns are significantly cheaper than conventional compartment kilns, but are limited to operating temperatures of about 65°C because of generally low air velocities. Because temperatures are lower, they generally use hot water as the heating medium. This provides cost savings compared to steam plumbing.

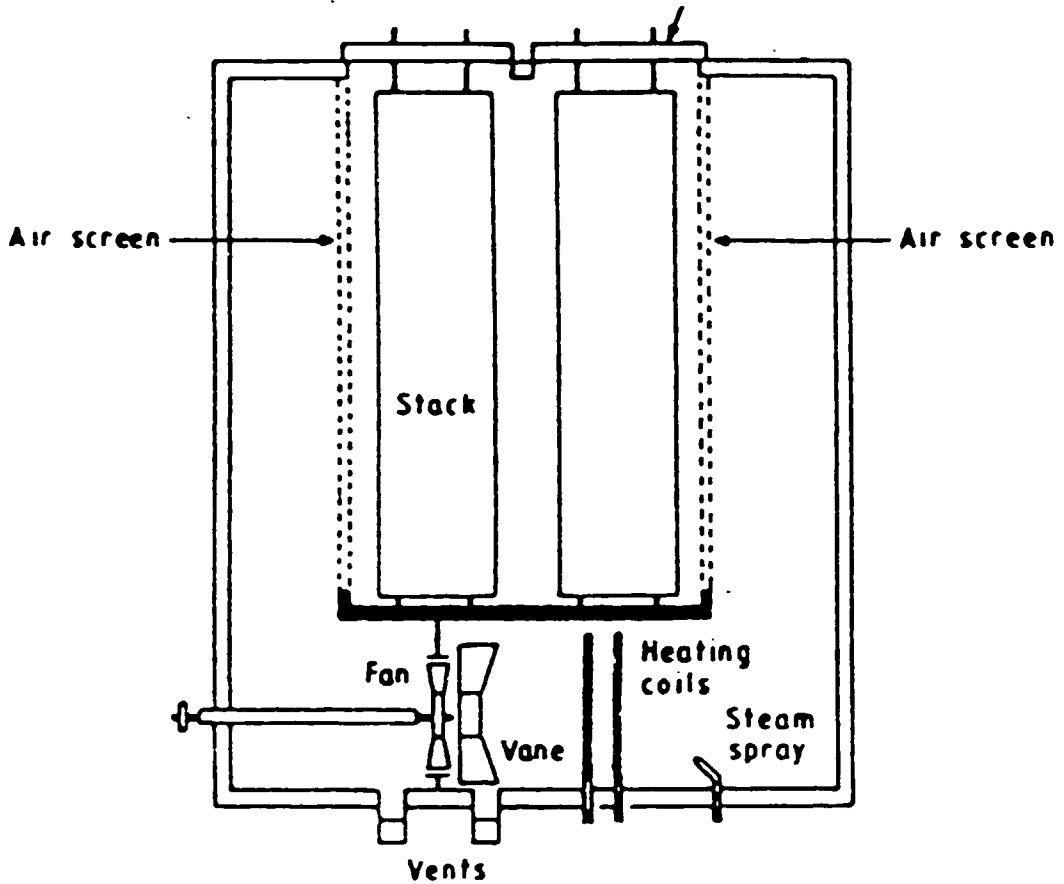

Fig. 3.

The screen kiln has only one fan and employs a horizontal air flow. Screens with approximately 20 percent void area provide sufficient static pressure for air velocities to be reasonably even throughout the stacks of timber.

Screen kilns are usually constructed from masonry or insulated timber frame with sheet covering.

The main attributes of the screen kiln are:

1. Capacity - limited to a maximum of 20 m³ because of limited air circulation.
2. Energy source - wood, gas or oil heating steam
wood, gas or oil heating water
wood, gas or oil heating oil
3. Capital Cost example.
1 x 15 m³ masonry kiln. indirectly heated with a wood waste fired hot water boiler.

kiln	US \$10.000
boiler, controls	US \$30.000
handling equipment	US \$15.000
Total	US \$55.000

4. Labour - assumes continuous boiler attendance is required 24 hours/day x 7 days/week x 2 people (does not include timber stacking)
5. Drying times (estimated)
25 mm thick tava will dry in 4-5 days from 25 percent to 12 percent moisture content.

E. Predryers

Predryers, as the name suggests, were developed to take the place of air drying performed prior to final kiln drying. A typical predryer is shown in Figure 4. These kilns are usually only used in cool wet climates where air drying conditions are unsuitable, although they are occasionally used for drying down to the final desired moisture content.

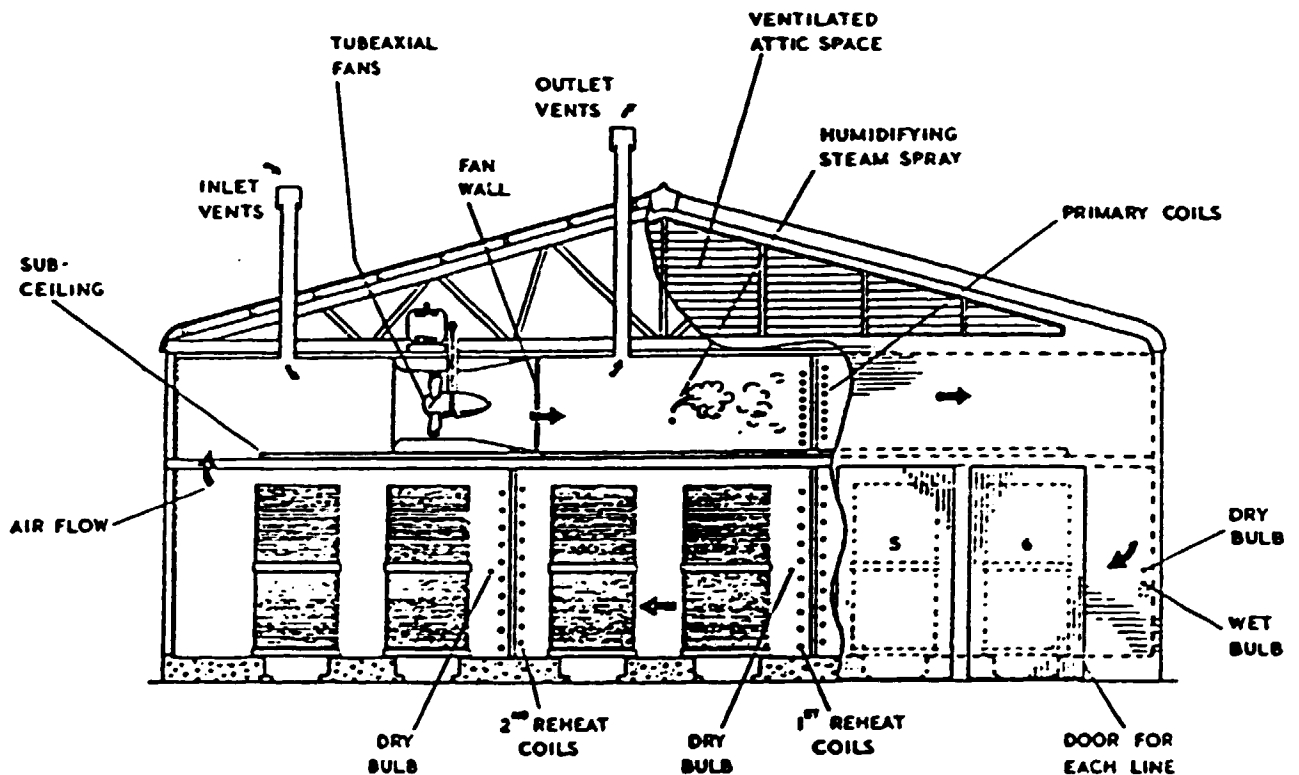

Fig. 4: Sectional elevation of a six line predryer.

Kilns are usually timber framed with fibre cement covering. Temperatures inside the kiln are low, often only 40°C. Air velocities through the change are also low, so the kilns only require two fans, despite the large capacity. The large width of the kiln and the high initial drying rates of green timber make reheat coils necessary even for predrying.

The main attributes of the predryer are:

1. Capacity - typically 50 m³ to 250 m³.
(some specialised predryers have been built with a capacity of over 1000 m³)

2. Energy source - wood, gas or oil heating steam
wood, gas or oil heating water
3. Capital Cost example.
1 x 6 line predryer with 90 m³ capacity, indirectly heated with a wood waste fired hot water boiler.
- | | |
|-------------------------------|-------------|
| kiln | US \$30 000 |
| manually fed boiler, controls | US \$30 000 |
| handling equipment | US \$15 000 |
| Total | US \$75 000 |
4. Labour - continuous boiler attendance.
7 days/week x 24 hours/day x 2 people, and
7 days/week x 24 hours/day x 1 person
(does not include timber stacking)
5. Drying times (estimated)
At 45°C Dry bulb temperature, 25 mm thick tava will dry in 6-9 days from 25 to 12 percent moisture content. it would take approximately 3 weeks to dry to 12 percent from green.
- F. Progressive Kilns

A schematic plan of a progressive kiln is shown in Figure 5. These kilns differ from most other kiln types in that they are continuously loaded with timber, rather than drying timber on a batch basis. The kiln has a very long air flow path through the stacks, so it becomes progressively cooler and more humid, thereby providing mild drying conditions for the green-off-saw stacks of timber pushed into the air exit end of the kiln. The timber gradually passes through the kiln as more green timber is pushed in behind it and kiln conditions become more severe as the air path becomes shorter.

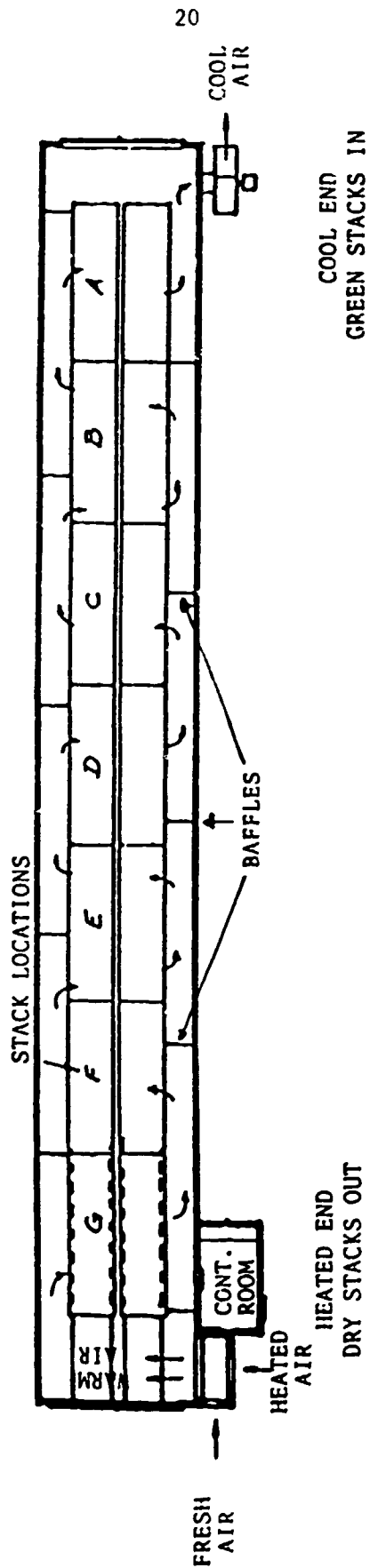

Fig. 5: Schematic plan of a progressive kiln.

These kilns are appropriate to relatively large volumes of a single species. A constant sawmill output is also required.

Kilns are usually constructed from a fibre-cement sheet over a timber frame, and are usually hot water heated.

The main attributes of the predryer are:

1. Capacity - typically 250 m³ for medium density hardwoods. Capacity depends on drying rate, and rate of feed through the kiln. This must be tuned to the drying characteristics of the wood and initial temperature and humidity of the air as it enters the kiln.
2. Energy Source - wood, gas or oil heating water
wood, gas or oil heating steam
direct fired gas.
3. Capital Cost Example.
1 x 250 m³ kiln, indirectly heated with a wood waste fired hot water boiler.

kiln	US \$40 000
manually fed boiler, controls	US \$30 000
handling equipment	US \$30 000
Total	US\$100 000
4. Labour - assumes constant boiler attendance.
7 days/week x 24 hours/day x 2 people
5. Drying times (estimated)
Residence time in the kiln for a pack is typically 45 to 60 days.

G. Vacuum Kilns

When wood is dried in a vacuum, the drying rate is high at quite low temperatures. It is therefore a very good method for drying collapse prone timber reasonably quickly.

The energy required to evaporate the water from the wood is usually supplied by electric "blankets" or flat metal platens between the wood layers, or by radio frequency heating. Conventional heating systems (ie air circulated over heat exchangers) do not work because there is insufficient air for efficient heat or moisture exchange once a vacuum has been drawn.

Vacuum kilns are very expensive, and, if they are radio frequency heated, the frequency of the RF needs to change as the timber's dielectric constant changes. The tuning of the kiln to suit particular timbers can be a protracted exercise.

Control and RF shielding requirements are high, so these kilns are only suitable where a high level of operator training and equipment maintenance is available. These kilns do dry timber quickly and well but operating costs are usually high, so they are only suited to the drying of high value speciality timbers.

The main attributes of a vacuum kilns are:

1. Capacity. 2 to 10 m³ is the most common range of sizes.
2. Energy Source - Electricity.
3. Capital Cost example.
1 x 10 m³ RF heated kiln.
US \$600 000 plus handling equipment.
4. Labour.
7 days/week x 24 hours/day x 1 person for continuous use.
5. Drying times - unknown for tropical hardwoods.

H. Radio Frequency (RF) Kilns.

RF is a rapid heater of water at particular frequencies. This principle is used in kilns where air is circulated over timber that is exposed to RF radiation. Like vacuum kilns, the equipment is expensive initially and requires a high standard of maintenance for its safe operation. In some countries, health and safety legislation makes the cost of shielding stray RF radiation very high.

This kiln type is, at this stage, not appropriate to developing countries because of its capital cost and high levels of technical expertise required to install and service the kilns.

I. Press (Platen) Drying

Timber dryers have been constructed using heated plates which press on both faces of timber. These plates heat the timber well above 100°C, while restraining it firmly in a flat condition. Drying is rapid and low levels of drying defects are reported. Equipment available at present is only suited to the production of high value products, as the capital cost is very high relative to the volume of timber that can be processed.

J. Chemical (Azeotropic) Seasoning

Chemical seasoning methods are not common because they can be expensive, can interfere with the timbers finishing properties, or can take long periods to dry to e.m.c.. Many of the solvent methods can cause significant levels of degrade in the heartwood. Solvent retention levels in the wood are sufficient to make the process expensive and the capital cost of equipment is high. They are not considered to be commercial at this stage and would be likely to be unsuitable for developing countries in any event.

VI RECOMMENDED KILN TYPE FOR INDUSTRY

The choice of any kiln type needs to be made in the context of the volume of timber to be dried, the species to be dried, available heat sources, climate, capital cost, running costs, products manufactured, and the availability of training operators and maintenance staff.

Western Samoa does not have suitably trained engineers familiar with vacuum kilns, RF kilns, press drying or Chemical Seasoning Plants. Also, these kiln types cannot be justified given their very high capital costs.

Progressive kilns are not well suited to any of the sawmilling operations in Samoa because most have a range of species, or their output is too small and/or intermittent. (Progressive kilns must have a constant, regular input of the same species of green timber to provide the correct drying conditions).

Predryers are designed for the drying of timber from green down to approximately 20 percent moisture content. After this, timber is normally transferred to a conventional kiln for final drying. Some operations use a predryer of the design outlined in Chapter V, Section E, to dry to final moisture content, but drying is slow (not much faster than a solar kiln) and it is very difficult to accumulate sufficient wood of the same thickness and species at one time to make this efficient - generally species and thicknesses are mixed, so that the drying schedule used is the one appropriate to the slowest drying species and thickness. It is the authors opinion that a predryer in any of the Samoan Sawmilling operations would lack the flexibility to dry a range of timbers in small batch lots.

Conventional compartment kilns, dehumidifier kilns, solar kilns and screen kilns could all operate at the scale of operations of the timber industry in Samoa. When correctly operated, all are capable of good quality drying. The choice between them depends on their relative costs of drying and the availability of sufficient wood waste for the conventional and screen type kilns.

Whatever the kiln type chosen, it is considered desirable to air dry the timber until it is reduced to approximately 25 percent moisture content. The climate is ideal for air drying - reasonably rapid drying, but with minimal degrade because the relative humidity is around 80 percent for most of the day.

Appendix 4 provides a comparison of the kiln drying component of drying costs for each of the kiln types for yearly kiln throughputs of 600 m³ and 1200 m³ of tava. These are summarised in the following table:

<u>Kiln Type</u>	<u>Volume/annum</u>	
	<u>600 m³</u>	<u>1200 m³</u>
Conventional	US \$77.16/m ³	US \$48.81/m ³
Solar	US \$28.17/m ³	US \$20.73/m ³
Screen	US \$66.74/m ³	US \$41.66/m ³
Dehumidifier	US \$55.65/m ³	US \$44.24/m ³

Coconut wood kiln drying costs are approximately 1.5 times the above figures because of slower drying rates.

The high cost (by world standards) of conventional and screen kiln drying is due to the high labour components for continuous boiler attendance being spread over relatively small volumes of timber. Dehumidifier drying costs are also high by world standards as a result of very high electricity costs (US \$0.143/kwhr).

A. Recommended kiln type for a coconut sawmill.

For a coconut sawmill drying 1200 m³/year of mostly 25 mm timber, it is recommended that the timber be air-dried to 25 percent m.c. first and that final drying should be carried out in solar kilns. Solar drying is approximately US \$20/m³ cheaper than other alternatives, although there is a need to add the cost of a waste disposal burner to dispose of sawmill residue for the comparison to be strictly valid. At a capital cost of US \$10 000 and using one operator, this adds US \$4.00/m³ to the effective cost of solar drying.

There are other factors besides drying cost to consider. Electric supplies are intermittent in Samoa. This will affect dehumidifier kilns greatly, as these kilns are slow to retain lost heat, and operating costs will rise steeply. Conventional and screen kilns are also affected, although much less. For these, electricity blackouts cause the problem of boiler shutdown because of safety interlocks and poor burning without forced air draft. Dehumidifier, conventional and screen kilns all have temperature and humidity control equipment that requires a reasonable quality power supply to function well. Solar kilns have no electrically operated controls. If there is an interruption to the power supply, the air circulation fan in the kiln stops, with very little effect beyond a small reduction in drying efficiency.

Kiln maintenance is simple and inexpensive for solar kilns, compared to other kiln types. Replacement of the solar kiln cladding may be required after about 8 years, but this costs only about US\$3000 and can be done by semi-skilled local staff. Maintenance on dehumidifier kilns is also relatively simple, as they are very similar to most refrigeration plants operating in Samoa. Trained maintenance personnel are therefore available. Conventional and screen kilns both require moderate levels of maintenance, largely due to the maintenance of the boiler.

Solar kilns are modular, so that their construction can be phased - one kiln initially, with more built as drying requirements increase. The quality of drying with solar kilns is usually very good because of the slow rate of drying.

There are numerous designs of solar kilns available. UNIDO has experience with several solar drying projects throughout the world. Most solar drying research has found that the better designed kilns have very similar performance. A suitable design that has been working well throughout tropical and sub-tropical regions of Australia and Vanuatu is contained in Appendix 5. Kilns to this design were first built 12 years ago in Australia, and there are now over 20 operating commercially. They have been found to reach peak temperatures of 65 degrees on sunny days with ambient maxima of 30, and usually are 20 degrees hotter than ambient from 9.00am through till 3.30pm in a sub-tropical climate. Equivalent or better performance can be expected in Western Samoa.

This particular kiln utilises a timber frame which can be fabricated on site with local timber and labour. Other kiln designs that have proved their performance in tropical climates would be suitable alternatives.

B. Recommended kiln type for furniture manufacturers.

For furniture manufacturers, the choice of kiln type is between solar drying and dehumidifier drying as they do not generate sufficient wood waste to operate a boiler system. It is clear from the cost comparison that solar kilns are appropriate for this segment of the industry. The design contained in Appendix 5 is suitable.

VII INFRASTRUCTURE REQUIRED FOR MULTI-USER DRYING FACILITY

Because of the need for furniture manufactures to use kiln dried timber to avoid shrinkage problems, all expressed strong interest in the concept of a drying facility set up on a co-operative basis to service their industry's needs. The volumes of timber which require drying are certainly sufficient to warrant such an operation - an air drying yard and two 15 m³ solar kilns with suitable handling equipment would service the immediate needs.

A co-operative drying facility for use by a number of companies needs to be well organised, have good administration and needs to fit into an organisational structure that is conducive to its operation. Most importantly, these details need to be worked out prior to the project commencing. The infrastructure suggested in this chapter should be regarded as a draft. Alternatives are possible, but the most important aspect is that there is agreement and commitment by all parties involved. This needs to be co-ordinated, and this would be best done by the Department of Economic Development. In the authors opinion, there are two main requirements for the success of such a drying facility:

1. The furniture manufacturers must act as a cohesive group, rather than individual companies. This is particularly important for the scheduling of drying in the kilns and the financial administration of the facility. The best way to achieve this is through the formation of a formally constituted Furniture Manufacturers Association.

2. The kilns should be located on independently owned land - not on the site of one of the furniture manufacturers. Although one manufacturer offered a site, there would be difficulties if the site owner wished or was forced to sell his assets. In addition, there may be friction between users because of the perceived advantage that the host company would have. Kilns would therefore be best located on either land owned by the Furniture Manufacturers Association, or leased from the government.

Several sites were investigated for the drying facility. The Forestry Division of the Department of Agriculture, Forests and Fisheries have offered, in principle, a suitable 0.5 ha site adjacent to the Forestry Research Buildings at Vailima. They have also offered to fund one full time employee for kiln operation for two years, as it is part of their charter to improve timber utilisation in W. Samoa. The main drawback of this arrangement is that the Furniture Manufacturers Association, if formed, may not wish to involve the Forestry Division in the project.

An alternative site would be the land administered by the Department of Economic Development at Vaitele. DFD have established a 12 acre Small Business Centre, leased from WSTEC. The Department has indicated that it would consider an application by a Furniture Manufacturers Association to

lease a site at the Centre. This option is likely to be more attractive to the Association than Forestry land.

A. Drying Facility - Organisational Structure and Operation.

The Drying Facility would require one Supervisor and two timber handlers. The Supervisor would be responsible for:

- . stock-taking all timber arrivals for each company
- . stock-taking all timber dispatched
- . preparation of invoices and general book-keeping
- . supervision of 2 employees.

The duties of the 2 employees would be:

- . stacking timber in preparation for drying
- . loading and unloading the kilns
- . monitoring of moisture content

Volumes of timber handled would be small, about 400-600 m³/year, so nighttime operators would not be required.

The Furniture Manufacturers Association should employ these 3 people, and should fix the cost of drying to recover operating costs and develop a capital reserve for maintenance. It would be best to set a price per cubic metre per day, as this accounts for different drying rates due to species and thickness and different initial moisture contents. Assuming external funding of the kiln, a price of WS \$4/m³/day would provide the following expenditure/revenue situation for a years operation.

Expenditure	Wages	WS \$18 000
	Electricity	3 500
	Maintenance	1 000
	Lease of land	5 000

		WS \$27 500

Revenue	Timber Drying at 100% capacity	WS\$37 800
	at 73% capacity	WS\$27 500 (break-even)

To overcome initial cash flow difficulties, external funding will be required for a period of 3 months. Total external funding for the project would therefore be as follows:

2 solar kilns (installed)	US \$20 000
Handling and laboratory Equipment	US \$15 000
Local engineer (1 month)	US \$ 2 000
Expert - Construction (1 month)	
and Training (2 months)	US \$25 000
3 months operation WS \$7 000	US \$ 3 200
Contingency (10%)	US \$ 6 500

Total	US \$71 700

Appendix 6 lists the duties of the expert for installation and training.

The local engineer would be responsible for local building authority permits, sourcing of local materials and foundation preparation.

VIII FUTURE CHANGES TO THE TIMBER RESOURCE

A. Indigenous Species

Most of the indigenous forest resource is located on Savaii. The merchantable forests are categorised into four groups depending on the principal species. The sawlog volumes as at August 1988 are Tava (42 percent), Asi (28 percent), Mamalava (25 percent) and Tamanu (5 percent). Figure 6 shows a graph of the decline of merchantable sawlog volumes. It can be seen that, if the same rate of decline continues, the indigenous forests will be exhausted by 2003. However, Forestry Division staff now consider that the Savaii and Upolu commercial resource will be exhausted by 2001. This is because of the effect of Cyclone Ofa and a likely increase in awareness of conservation issues.

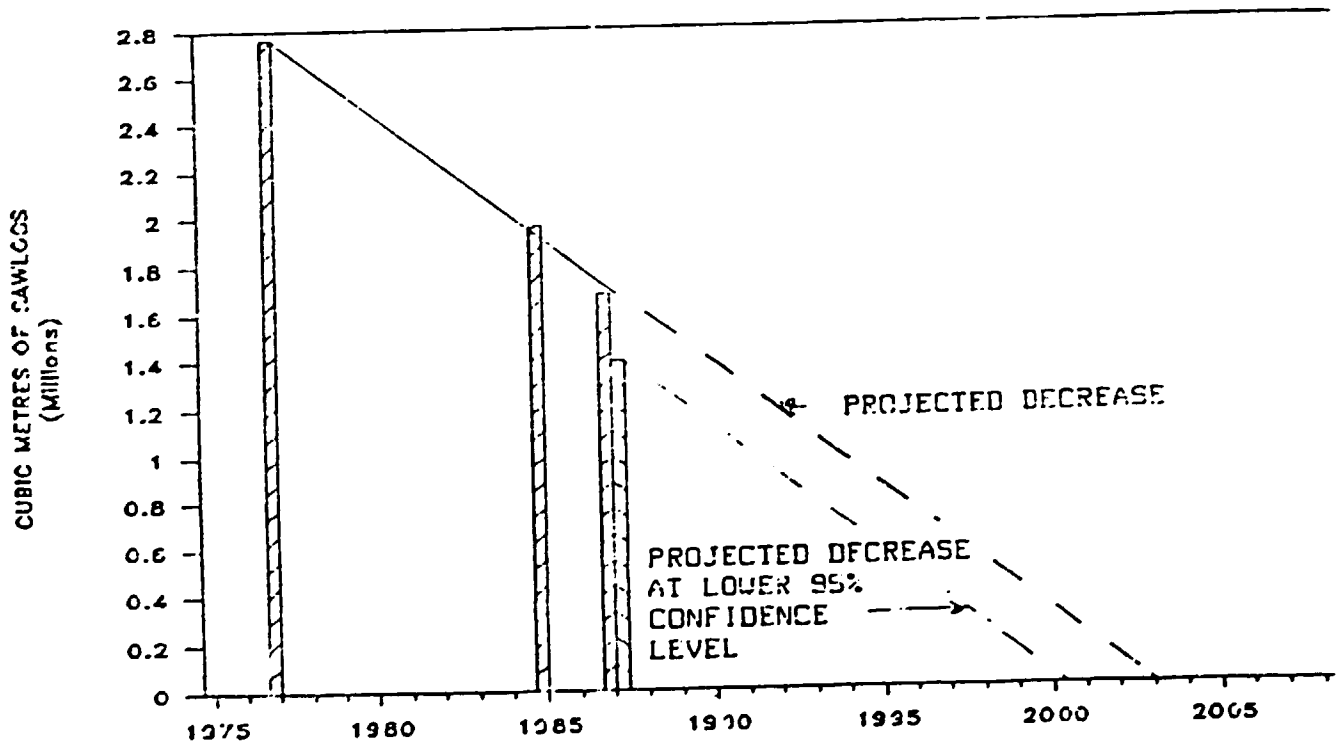

Fig. 6: Decline of merchantable sawlog volumes in the indigenous forests of Savaii

B. Plantation Species

The plantation program in W. Samoa was established as a replacement resource for the indigenous forests. 6000 ha would be able to meet the domestic demand of 30 000 m³/year on a sustainable basis. As at June 1st, 1990, 3018 ha is the total planted area. The remaining 3000 ha needs to be planted over the next 5 years to enable the plantation species to replace indigenous forest as the main source of sawlogs by 2011.

Accordingly, there is a ten year period where there will be significant timber shortage in Western Samoa. Imports or alternative timbers such as coconut will need to provide the shortfall during this period.

C. Impact on Wood Drying Requirements

Wood drying requirements will remain fairly static for the next ten years. Imported timber is likely to be kiln dried, therefore there will be a low demand for local drying of hardwoods in the years 2001-2011. After this time, the drying of plantation species should provide sufficient timber for the furniture industry.

The shortage of timber after 2001 is likely to provide the motivation for coconut wood utilisation in W. Samoa. It is unlikely that this utilisation will decline as the plantation timbers are phased in, as most plantation species are lower density, decorative timbers. *Eucalyptus deglupta* is really the only utility species planted that is well-suited for local structural purposes.

IX. CONCLUSIONS AND RECOMMENDATIONS

A. Conclusions

The following conclusions can be drawn from this consultancy.

1. Coconut Wood Products Limited is unlikely to start operating in the near future.
2. The indigenous timber resource will be exhausted by 2003 at present rates of cutting, given existing demand and forestry management practice. A further reduction of forest area available for logging is probable given the increase in awareness of conservation issues. Forestry officers consider the year 2000 as a more realistic date. Plantation species will be unable to replace the indigenous forest as the main source of sawlogs to supply local demand until probably year 2011.
3. Because of current timber shortages, which are likely to continue, and the void in log supplies in from 2000-2011, the development of the coconut resource is both desirable and probable. The main difficulties which face a coconut wood processing venture are the lack of a guaranteed log supply, funding requirements of the organisation responsible for senile tree replacement, and the possibility of a more fragmented ownership of plantations with the restructuring of WSTEC.
4. The climate of Apia is very well suited to air drying and solar kiln drying. Timber that has been well air dried to e.m.c. (17 percent) undergoes further shrinkage in offices, particularly when they are air-conditioned. Kiln drying is therefore essential if the local furniture and joinery industry is to maintain its market share.
5. UNIDO assistance in provision of kiln facilities and training is better directed to the furniture and joinery industry, rather than the sawmillers, because:

* the furniture industry has a much more direct interest in the quality of drying, since poorly dried timber causes customer

dissatisfaction, higher production costs and lower quality of output.

* the very high demand for structural timber means that sales of green timber are assured. Smaller users (often furniture or joinery manufacturers) have difficulty obtaining supplies, so are unwilling to complain about the quality of allegedly kiln dried timber.

* although 300 m³ of kiln capacity exists at Samoa Forest Products Ltd., Savaii, profitability problems makes its future uncertain. The kilns are not being used to their potential, but the strong market for green timber discourages any development or commitment to properly dry timber.

* the uncertain nature of the sawmilling industry after the year 2000.

* the furniture industry has a good understanding of the moisture content requirements for their products, whereas the sawmillers generally do not.

* the furniture industry can exist through the supply problem period of 2000-2011 by the use of imported timber and coconut wood.

* the larger furniture industry members have demonstrated their business acumen by their profitability. This makes the success and longevity of an aid funded project based about this industry more probable.

6. At this stage, the proper kiln drying of indigenous timbers will have more benefit than the kiln drying of coconut wood, since the existing furniture market is based about the former.

7. Solar kilns are the most suitable kiln type for use by the furniture industry in Apia, because of:

- * low capital cost
- * very low running cost
- * lack of sufficient wood waste to provide energy for other kiln types
- * absence of any complicated controls or electric
- * attendance of full time operators is not required
- * very low maintenance costs
- * high quality of drying
- * design is easily copied by others requiring kiln facilities
- * ideal climate for their use

8. If a coconut processing facility does start operation and requires drying facilities for approximately 1000 m³ (as originally proposed), the most suitable drying process would be a properly designed air-drying yard and 3 solar kilns, each of 15 m³ capacity. This provides the lowest cost of drying per cubic metre, best control of drying defects such as collapse and warping and does so with a level of technology appropriate to this country.

9. Solar kilns located at one of the larger furniture manufacturers are likely to create difficulties because of the perceived advantage that the host company would have. In any event, location on private land may cause problems if the host company wishes to relocate or sell its assets.

10. Two suitable sites for the 2 solar kilns recommended are available. The first is on land at Vailima owned by the Department of Agriculture, Forestry and Fisheries. This is approximately 5 km from the centre of Apia. The Director of this Department has agreed in principle to the project, pending a firm proposal. Suitable laboratory equipment is available on site, and the Division has a Timber Utilisation Officer who is able to provide seasoning advice. As they consider that part of their charter is to encourage proper timber utilisation, Forestry have agreed to provide land and one person for two years for the construction and operation of the kiln. After two years, they expect industry to take over the running of the kilns.

The second site available is on land at Vaitele leased by the Department of Economic Development for the purpose of establishing a Small Business Centre. This is a better site for solar drying from a climate point of view, but would not have the same degree of impact by Forestry staff.

B. Recommendations

There is an urgent need to provide drying facilities for the furniture industry to enable them to produce items which are suitable for the domestic and business environment. Shrinkage of timber because of inadequate drying is increasing the importation of timber and complete furniture items, particularly for commercial developments.

In order to address this need, it is recommended that solar kiln facilities be built in Apia. It is recommended that:

1. The furniture industry should set up a formally constituted Association to negotiate the building of solar kiln facilities and to administer the kiln project once drying commences. In particular, the Association should be responsible for the cost of operation of the drying facility, funded from revenue obtained from drying. The Association should set the cost of drying to recover costs and accumulate sufficient reserve for maintenance. It is suggested that WS \$4.00 per m³ per day is sufficient.

2. The Furniture Manufacturers Association should negotiate with the Department of Economic Development and the Forestry Division to choose the site for the drying facility. The climate at the DED Small Business Centre at Vaitele is marginally better for solar drying than the Forestry land at Vailima.

3. Details of the infrastructure (Chapter VII) should be circulated by the Department of Economic Development to the following:

- Forestry (Malaki Iakopo)
- Lober Industries (Joe Lober)
- S. Young Construction Ltd. (Steve Young)
- Milford Development Ltd. (August Milford)
- Saleufi Joinery (John McDermott)
- Pat Ah Him Co. Ltd. (Pat Ah Him)
- G.M.A. Construction Ltd. (Philip Wise)

- Laufiso Iairo Wongling
- New Samoa Wood Industries (Eletise Ioane)
- Bluebird Industries (Andrew Ahliki)
- T.V. Corporation (Tui Vaai)

The furniture manufacturers should be requested to provide letters of agreement in principle to using the facility, an undertaking to run the facility, and the volumes of timber that they expect to dry in the facility in its first year of operations. The project should be contingent on getting assurances of a minimum total of 400 m³ per year to be dried.

4. UNIDO should be requested to fund the construction of 2 solar kilns, each of 15 m³ capacity, the timber handling system, stickers, storage shed, one moisture meter (including spare needles), laboratory kiln and weighing scales.

5. UNIDO should also be requested to fund the running costs of the drying facility for 3 months. After this period, income from drying should be sufficient to pay wages and running costs.

6. Finally, UNIDO should be requested to fund a drying consultant for a period of three months to supervise the construction of the kilns and to train Forestry and Industry personnel in timber drying theory and practice. This consultant should also conduct a detailed technical evaluation of Samoa Forest Products kilns in Savaii to identify their condition, prepare a maintenance schedule and train operators in the correct use of these kilns. The consultant should also develop moisture meter correction factors for the range of local commercial species, and document the performance of this design of solar kiln.

7. Forestry staff should encourage the development of similar kilns through the provision of extension advice and demonstration of the kilns in use, irrespective of whether they are at Vailima or Vaitele.

References or Documents Consulted

- Alston, A.S. (1982) Timbers of Fiji. Department of Forestry, Suva, Fiji. 183p.
- Bragg, C. (1986). An equilibrium moisture content survey of timber in Queensland. Department of Forestry, Queensland Technical Paper No. 40.
- Brion, H.P. (1988). Technical assistance for the development of the furniture and joinery industries of Western Samoa. UNIDO report DP/RAS/86/075.
- FAO (1985) Coconut wood processing and use. FAO Forestry Paper 57. Food and Agriculture Organization of the United Nations. Rome.
- Hartley, J. & Marchant, J. (1988). Methods of determining the moisture content of wood. Forestry Commission of New South Wales Technical Paper No. 41.
- Haslett, A.N. (1986) Properties and uses of the timbers of Western Samoa - Plantation grown exotic hardwoods. Ministry of Foreign Affairs, Wellington, New Zealand. 26p.
- Kininmonth, J.A. (1979). Current state of knowledge of drying of coconut wood. Proceedings of Coconut Wood - 1979 Conference, Manila & Zamboanga 22-27 October. Philippine Coconut Authority.
- Kininmonth, J.A. (1982). Properties and uses of the timbers of Western Samoa - indigenous hardwoods. Ministry of Foreign Affairs, Wellington, New Zealand. 57p.
- Martel, F. (1990). Quarterly report to the Department of Agriculture, Forests and Fisheries by NZBAP Forestry Development Project, Western Samoa. (unpub).
- Nile, E.H. (1989). Forest plantation species selection for Western Samoa. Forest Genetic Resources, Information No. 17, Food and Agriculture Organization of the United Nations.
- Springford, C. (1988). Review of the indigenous forest resources of Savaii, Western Samoa. Department of Agriculture, Forests and Fisheries, Western Samoa. (unpub)

APPENDIX I

UNITED NATIONS INDUSTRIAL DEVELOPMENT ORGANIZATION

PROJECT FOR THE GOVERNMENT OF WESTERN SAMOA

Assistance in the Establishment of a Pilot Lumber Kiln Drying Plant

JOB DESCRIPTION

XP/SAM/90/015/11-01/J-12209

- Post title:** Timber drying consultant.
- Duration:** One month.
- Date required:** As soon as possible.
- Duty station:** Apia.
- Purpose of project:** To establish a pilot lumber kiln drying plant and to train personnel on the operation of the kiln drying plant.
- Duties:** The consultant shall briefly survey the current situation with respect to wood drying in Samoa and assess local expertise (if any). He shall, based upon information obtained from the Samoa Coconut Wood Products Limited's sawmill, determine the volume of the proposed timber drying kilns and namely assess whether the two chambers, each of 5000 BFT is realistic.
- He shall study the suitability of the various wood drying systems, namely conventional steam heated kilns, flue-gas hot-air kilns, dehumidifier kilns and, if appropriate, solar kilns and even vacuum type kilns. In assessing the relative merits of the various systems, he shall bear in mind the availability or lack thereof of power, woodwaste to operate conventional kilns and comparative costs of these two sources. He shall also determine whether conventional steam heated kilns are applicable under Samoan conditions. In determining the above, he shall bear in mind ease of maintenance as well as manpower skills available.
- Based on this comparative study, the consultant shall draw up technical specifications for kilns to be

introduced in the Samoa Cocowood Products Limited, justifying his choice and recommending the type of chamber.

In case he selects cement block or other masonry chambers, he shall supply detailed construction plans for these chambers to be constructed by local contractors and draw up terms of reference and technical specifications for a call for offers for the construction of the said chambers.

He shall also draw up the technical specifications of the laboratory and control equipment to be provided by the project.

The consultant shall determine the availability of technical personnel in Samoa to install the kilns and whether expatriate personnel from the kiln suppliers should be provided or not. In case he deems these to be necessary, he shall enumerate in detail the duties that the local personnel will perform and those that will be the responsibility of the kiln supplier's personnel.

He will include all the above in a technical report.

Qualifications:

Wood technologist or engineer with considerable experience in kiln drying of lumber. Experience with a wide range of kilns and with a wide range of tropical timbers highly desirable.

Language:

English.

Background information: A good volume of timber produced from the forests of Western Samoa is exported as sawn timber and veneer. A very small portion of the forest timber yield is converted into secondary wood products. Whatever furniture or joinery products thus produced are sold only in the domestic market for the quality of the products are definitely far below the levels acceptable on the foreign market.

There also exists in Western Samoa sufficient coconut wood as the country has an on-going coconut replanting programme. Current levels of replanting activities make an estimated 18,860 MBF (round measure) of coconut stems available annually to the wood processing industry of the country.

Coconut wood is currently being processed by the Samoa Coconut Wood Products Ltd. (CWPL) a sawmill which is jointly owned by the Western Samoa Trust Estates Corporation (WSTEC) and the Development Bank of Western Samoa (DBWS). This sawmill also operates a pressure treatment plant for the production of fencing posts and electric power transmission and

lighting poles. The company also has a modest moulding plant.

In spite of the availability of ample wood materials and relatively low levels of labour costs, the secondary wood processing industry of the country has not developed satisfactorily during the last few years. Difficulty is still experienced with regard to improving further the quality of locally produced furniture and in producing for export higher value added wood based items. Furthermore, the utilization of coconut wood for furniture and other similar items is not common in spite of the abundance and relatively lower price of this material as compared to traditional hardwood species.

APPENDIX 2

In the course of this mission, the following people were consulted:

Mr. Nigel Ringrose:	Resident Representative, UNDP, Suva.
Mr. Sairusi Bulai:	A/Principal Utilisation Officer, Fiji Ministry of Forestry, Suva.
Mrs. Sarwar Sultana:	Deputy Resident Representative, UNDP, Apia.
Mrs. Fu'a Hazelman:	Programme Assistance, UNDP, Apia.
Mr. Misiolo Sofe:	Deputy Director, Department of Economic Development, Apia.
Mrs. Itagia Faumui:	Industries Division, Department of Economic Development, Apia.
Mr. David Thompson:	FAO Consultant.
Mr. Toouta Aloalii:	G. Meredith and Associates (Architects) Apia.
Mr. Rudolph Meredith:	Assistant General Manager, Development Bank of Western Samoa.
Mr. Steve Young:	Manager, S. Young Construction Ltd., Apia.
Mr. Joe Lober:	Managing Director, Lober Industries Ltd., Apia.
Mr. August Milford:	Milford Development Ltd., Apia.
Mr. John McDermott:	Managing Director, Salenfi Joinery, Apia.
Mr. Pat Ah Him:	Pat Ah Him Co. Ltd., Apia.
Mr. Philip Wise:	GMA Construction Ltd., Apia.
Mr. Electise Toane:	Manager, New Samoa Wood Industries, Vaitele.
Mr. Andrew Ahliki:	Manager, Bluebird Industries Ltd., Apia and Gataivai.
Mr. Tui Vaai:	Manager, T.V. Corporation Ltd., Apia and Gataivai.
Mr. Farani Posala:	Manager, F.P. Architects, Apia.
Mr. William Brown:	General Manager, Samoa Forest Products Ltd., Asau.
Mr. Malaki Iakopo:	Assistant Director, Forestry Division Department of Agriculture, Forestry and Fisheries, Apia.
Mr. Tapa Suaesi:	Utilisation Officer, Forestry Division, Apia.
Mr. Chong Wong:	Company Secretary and Acting Financial Controller, WSTEC, Apia.
Mr. Tupuola Tavita:	Director, Department of Agriculture, Apia.
Mr. Samuelu Enari:	Department of Economic Development, Apia.

APPENDIX 3

**COCONUT WOOD PRODUCTS LTD.
TENDER DOCUMENT**

In this tender document, you will find the following:

- * A background to the operations of the enterprise.
- * A list of assets included in this offer.
- * Instructions to tenderers.

Background

CWPL commenced operation in 1976 as a result of New Zealand financial and technical assistance. Its ownership and management have changed hands four times. The operations were closed down in 1981 and between 1982-1985. At present, CWPL is a joint-venture company owned by WSTEC and DB&S.

The mill can produce a wide range of products, which, given adequate quality, sound marketing and reliable, uninterrupted delivery, should find a ready market in Western Samoa and overseas.

Average daily production capacity is estimated at 24,000 super feet (or for 240 working days p.a., 600,000 sq.ft.). Annual capacity is estimated to be 25,600 stems. WSTEC is planning to replant 1,000 acres p.a. and guarantees CWPL 600 acres at 50 stems per acre or 30,000 stems. This replanting programme extends over the next 15 years for most of WSTEC's plantations. Thus, under current conditions, a guarantee for raw materials is assured for CWPL for at least the next 20 years.

Monthly sales volumes of currently produced lines of products are indicated in the table below:

<u>Product Sales</u>	
(WS\$ - August 1989 - unaudited)	
Fence posts	2,766
Timber	994
Wall panels	
Roofing tiles	
Dressed timber	
Rough-sawn timber	
Batten	
Firewood	20
Sawdust	22
	3,802

The following is the summary of financial performance in years 1986-1988:

COCONUT WOOD PRODUCTS LTD.
Operating Results
WS\$ 000

	<u>1986</u>	<u>1987</u>	<u>1988</u>
Sales	70	91	100
Cost of Goods sold	<u>103</u>	<u>72</u>	<u>76</u>
	(33)	19	24
Operating expenses	<u>144</u>	<u>135</u>	<u>22</u>
Net loss	(83)	(52)	(53)

Assets

- * Leasehold land - The site consists of 4 acres for which an annual rental of WS\$ 4,400 is paid to WSTEC. The lease was signed in 1984 for a 20+20 year term. The land has access to the main island road, and is sited within the Vaitele industrial estate. The property is fenced on all sides (wire) and has a direct access road, and internal dirt tracks.
 - * Buildings - These consist of eight structures located on land leased from WSTEC. The condition of each of these major buildings is as follows:
 - Wood-working shop and product-display room - wood-working shop in good conditions, some roof repairs needed; wood tile roof over the product display room needs replacing.
 - Two drying shed (air drying) - one in good condition minor repairs needed, second needs major repairs including the foundations.
 - Timber treatment plant/chemical store/office - serviceable, concrete floor in treatment plant.
 - Sawmill - earth floor, timber structure, asbestos roof needs maintenance.
 - Manager's office - serviceable.
 - Storehouse/garage - not used, timber sheathes - serviceable, minor repairs on one wall needed.
 - House and a Samoan fale - good condition
- Plant and Machinery - major items of equipment include:
- Three Batman Varteg sawmills - only one operational; remaining two could be used for parts.
 - One Toyota forklift - operational

- One Nissan pickup (1985)
- Two tractors - Ford 5000 - operational - one used as power plant for sawmill.
- CCA treatment plant - operational. mixing tanks, some valves and the piping system need replacing.
- Two chainsaws - "Stihl" operational, "Solo" needs minor repairs.
- One Woodcutter sawbench.
- Two woodcutter radial arm saws
- One Challot scallop machine
- One Armucrup 3-side planer - minor repairs needed.
- One Armucrup 4-side planer
- One Dauckaert 24" speed sander
- One Atlas Copco LE9 compressor.
- Two Woodcutter dust extractor units and fan
- Electrical switchboard
- Power unit for the sawmill - major repair needed
- Other fixed assets consisting of loose tools, land improvements, and office furniture and equipment.

Stock - the average stock (8-month average, February-August 1989) is WS\$26,729 worth of raw materials, work-in-progress and finished products.

INSTRUCTIONS TO TENDERERS

Your offer should include the following:

- * Price offered for CWPL as a going concern. A bank cheque amounting to 10% of the price offered should be attached to your offer.
- * Full disclosure as to ownership and management team. All financing arrangements must be complete. Tender offers based on conditional financing will not be considered.

Coconut Wood Products Ltd. is offered as a going concern, with all liabilities paid off. All equipment included in this tender offer is offered on "as is" basis.

Tenderer is required to guarantee the employment of current employees for a period of not less than three (3) months as of date of CWPLs transfer.

It is the tenderer's responsibility to examine carefully the whole of the tender document and to satisfy himself that its full import is understood. It is also the tenderer's responsibility to obtain at his own expense all information required to arrive at the tender bid price. No claims for alteration of the submitted tender amount will be entered on the ground of alleged misinterpretation or misinformation.

The Coconut Wood Product Limited's Board of Directors reserves the right to refuse any or all offers to re-advertise this tender.

An inspection of the premises may be arranged with Mr. Roger Hazemann, Treasury Department or Mr. Pati Liu, CWPL Manager. Ph. 21135.

All tender offers should be marked "Coconut Wood Products" and deposited in the Tenders Box, Treasury Department by 4:00 p.m., 22 January 1990.

APPENDIX 4

Drying costs for four kiln types at volumes of 600 m³/year and 1200 m³/year are shown below, assuming air drying to 25 percent m.c. All costs are US\$ and are based on the drying of tava (the most common of the indigenous hardwoods, and also typical of drying rates for the common species).

1. CONVENTIONAL KILN

Drying time 3 days for 25 mm.

Assume kilns are worked 250 days/year, therefore 83 kiln charges per year.

At 600 m³/year, require nominal kiln capacity of 7.5 m³.

At 1200 m³/year, require kiln capacity of 15 m³.

	<u>At 600 m³/year</u>		<u>At 1200 m³/year</u>
(a) Capital			
kilns 1 x 7.5m ³	\$17,000	1 x 15m ³	\$20,000
boiler	\$30,000		\$30,000
handling equipment	\$15,000		\$15,000
	-----		-----
	\$62,000		\$65,000
(b) Operating			
2 people stacking		4 people stacking	
6 boiler operators		6 boiler operators	
1 kiln operator		1 kiln operator	
--		--	
9 people @ \$2500/year	\$22,500	11 people	\$27,500
electricity			
7.5kWx24hrsx250daysx\$0.143/kWhr	\$6,435	15kW.....	\$12,870
maintenance 10% of capital cost	\$6,200		\$6,500
annual capital cost @ 18% interest	\$11,160		\$11,700
	-----		-----
Total Operating Cost/yr	\$46,295		\$58,570
	-----		-----
COST PER CUBIC METRE	\$77.16		\$48.81

2. SOLAR

Drying time 12 days (worst case).

Assume kilns are worked 315 days per year therefore 26 kiln charges per year.

At 600 m³/year, require a nominal kiln capacity of 23 m³.

At 1200 m³/year, require a nominal kiln capacity of 46 m³.

	<u>At 600 m³/year</u>		<u>At 1200 m³/year</u>
(a) Capital			
kiln 2 x 15m ³	\$20,000	3 x 15m ³	\$30,000
handling equipment	\$15,000		\$15,000
	-----		-----
	\$35,000		\$45,000

(b) Operating costs		4 people stacking	
2 people stacking		1 kiln operator	
1 kiln operator		--	
--		5	\$12.500
3 people @ \$2500/yr	\$7.500		
electricity		4.5kW.....	\$2.027
3kWx10hrsx315daysx\$0.143	\$1.351		
maintenance			\$2.250
5% of capital cost	\$1.750		\$8.100
annual capital cost @ 18%	\$6.300		-----
			\$24.877
Total operating costs/yr	\$16.901		
COST PER CUBIC METRE	US\$28.17		US\$20.73

3. SCREEN KILNS

Drying time 5 days.

Assume kilns operate 250 days/year therefore 50 kiln changes per year.

At 600 m³/year, require a kiln capacity of 12 m³.

At 1200 m³/year, require a kiln capacity of 24 m³.

	<u>At 600 m³/year</u>		<u>At 1200 m³/year</u>
(a) Capital			
kiln 1 x 12m ³	\$10.000	2 x 12m ³	\$20.000
boiler, controls	\$30.000		\$30.000
handling equipment	\$15.000		\$15.000
	-----		-----
	\$55.000		\$65.000
(b) Operating costs			
2 people stacking		4 people stacking	
1 kiln operator		1 kiln operator	
6 boiler operators		6 boiler operators	
--		--	
9 people @ \$2500/year	\$22.500	11 people	\$27.500
electricity			
2.5kWx24hrsx250daysx\$0.143/kWhr	\$2,145	5kWx.....	\$4.290
maintenance			\$6,500
10% of capital cost	\$5,500		
annual capital cost			\$11.700
@ 18%	\$9.900		-----
			\$49.990
Total operating cost/yr	\$40.045		
COST PER CUBIC METRE	US\$66.74		US\$41.66

4. DEHUMIDIFIER KILN

Drying times 5 days.

Assume kilns operate 315 days/year, therefore 63 kiln changes per year.

At 600 m³/year, require kiln capacity of 10 m³.

At 1200 m³/year, require kiln capacity of 20 m³.

	<u>At 600 m³/year</u>		<u>At 1200 m³/year</u>
(a) Capital			
kiln 1 x 10m ³	\$35.000	1 x 20m ³	\$45.000
Handling equipment	\$15.000		\$15.000
	-----		-----
	\$50.000		\$60.000
(b) Operating costs			
2 people stacking		4 people stacking	
1 kiln operator		1 kiln operator	
--		--	
3 people @ \$2500/yr	\$7.500	5 people	\$12.500
electricity (includes initial resistance heating)			
8kW for 5days/charge (compressor & fans)			
15kW for 1 day/charge (resist. heating)			
1320kWhr/charge x 63 charges x \$0.143	\$11.892	2640kWhr....	\$23.784
maintenance			
10% of capital cost	\$5,000		\$6,000
annual capital cost @ 18%	\$9,000		\$10.800
	-----		-----
Total operating cost/yr	\$33.390		\$53.084
COST PER CUBIC METRE	US\$55.65		US\$44.24

APPENDIX 5

BUILDING NOTES FOR THE SOLAR KILN

These notes are to be read in conjunction with the plan and parts list provided on pages 53 to 70. The design is based on specifications provided in the W42 Queensland Timber Framing Manual (ie design wind speed 42 m/sec) published by the Timber Research and Development Advisory Council, which defines framing specifications for the construction of domestic housing. These notes are written as a series of building steps ordered in sequence, using frequent references to the numbered plans and numbered items on the parts list.

Before starting construction, it is advised that the trolley trucks and rails are purchased or at least made available. The reason for this is that the height of the trolleys will determine the height of the floor inside the kiln. The kiln design featured here is based on a kiln that has been constructed by the Queensland Forest Service in Brisbane. The trolleys used in that kiln are second hand crane truck trolleys, and the floor height is set at 600 mm above the concrete floor inside the drying room. Loading systems are commercially available through makers of timber handling systems. If taller trolleys are used then the materials list and the plans will need to be altered to compensate for a taller building.

* The site chosen for the solar kiln should maximise exposure to the sun on a northerly aspect (for the southern hemisphere). A flat well drained area 15m x 8m is required, with the long dimension oriented north - south, and preferably scraped clear of vegetation and obstructions.

* The specifications for footings provided in the plan are designed for use with timber floor construction in Queensland, where the underlying geology is stable. That is, where the foundation is parent rock, or material that is compact and has negligible shrink or swell capacity. If the builder is uncertain of the nature of the site or where the site soil comprises high density clays, then the builder should consult a geological surveyor or engineer to have the site sampled and appropriate footings designed according to the requirements of the foundation.

* The building should be sited to face true north as shown on sheet No: 3¹. Accurately mark out footings on the ground according to the layout on sheet No: 4. Dig trenches and pads ensuring footings are deep enough to be based on sound foundation soil, and not fill or top soil. The minimum sectional footing dimensions are given on section A - A' on sheet No: 6. All trenches and pads should be accurately dug to width and depth, and be free of loose debris, roots and water.

* Prepare steel reinforcing for strip footing under block wall. Use trench mesh item No: 1², with stirrups at 900mm centres, item no: 2 to build reinforcement frames tied with wire. The mesh frames should be supported 50mm from the sides and bottom of the trench to allow complete coverage by concrete.

¹ Numbers refer to the drawings on pages 53 to 68.

² Numbers refer to the parts list for the solar kiln, on pages 69 and 70.

from the sides and bottom of the trench to allow complete coverage by concrete.

* 10 mm steel tie down rods, item No: 41, and steel post shoes, item No: 43 are required to be cast into the footings as shown in section A - A' on sheet No: 6. Tie down rods can be prepared from steel rod, threaded one end and angle bent on the other as shown. Tie down rods and steel post shoes should be positioned using string lines, in each outer pier footing and along the line of the centre wall respectively, as shown on sheet nos: 5 and 6 ensuring accurate location and height. Particular attention should be given to the post shoes as these will define the line of the centre wall, and should support the posts above the height of the top of the concrete floor. 15 Mpa ready mixed concrete should be poured into the footings, and should be accurately levelled such that all piers and strip footing are at the same finished height. Tie down rods and post shoes can be inserted in the wet concrete after levelling, ensuring good contact with concrete. These will require temporary support in order to hold accurate position until concrete has cured.

* Concrete block piers and walls can be constructed on the foundation after the concrete has cured sufficiently. The height of the piers will be determined by the height of the stack trolleys. The plan allows for a floor height above ground of 744mm, and a trolley height of around 570mm. The block walls are made up of solid face blocks up to the height of the floor, and breeze blocks above the floor. Note that the solid face block wall is continuous around the perimeter of the drying room while the breeze block screens are on each side of the drying room only. (An alternative to the masonry block wall is to build the wall using timber. This can be done using a timber frame sheeted with plywood or timber to seal the section beneath the floor and vertical timber slats used to make a screen. These slats should be 50mm wide and create a void area in the wall of 25%.) The block walls are made from 3 courses of solid face blocks and 11 courses of breeze blocks at 200mm each course. A final course of blocks 90mm tall is required to bring the final height of the walls to 2889mm which is shown on sheet No: 8. During construction of the block wall, holes should be cast into the mortar to facilitate bolts that are required to fasten floor joists to the block wall as shown on sheet No: 6 section A - A'. Bolts are also required to be cast into the mortar at the top of each screen wall in order to fasten a bearer to take the roof rafters of the drying room. The detail is given in section G - G' on sheet No: 9. Having completed the block work, the two breeze block walls should be temporarily supported to prevent them falling over.

* The concrete slab floor can be poured at this stage although it can be left till later as required. The floor should be placed over a 50mm thick blinding of compacted sand or gravel, and sealed with a 0.2mm thick plastic membrane, item No: 5. Steel fabric reinforcement, item No:6, is positioned 30mm from the bottom of the concrete slab supported by chairs at 1m centres. 20Mpa ready mixed concrete is laid 125mm thick, and trowel finished.

* The sub floor framing can be constructed as soon as the block work has cured. The layout is shown on sheet No: 5. Floor bearers should be positioned, with any joints lapped over piers and fastened by tie down bolts. All Timbers should be underlaid with ant capping. Where the floor joists are bolted to the block wall strip ant capping is required, which can be made from 100mm X 100mm galvanised flashing, item No: 40.(see sheet nos 6 and 7). Butt joints into the block wall floor bearers should be fastened with joist hangers as

shown on sheet No: 6. and nailed off with the spiral shank nails. item no: 30. At this stage the bearers for the drying room rafters should be bolted to the top of the screen walls. Inside the drying room, the side hobs can be constructed as depicted on sheet No: 6. and the frames ramset nailed to the concrete floor.

* Having completed the sub floor framing, the ply flooring can be laved. The plywood, item No: 19. should be fixed with clouts item no: 28.

* When the floor is complete the timber frame can be built. The framing is constructed in order from the inside out. That is, the drying room is built first followed by the external frame. All frames are best prefabricated while laved out on the ground, temporarily braced and lifted into position. Note that all studs are positioned at 600mm centres and rafters at 900mm centres. When all the frames are up then the building can be checked for correctness, plumbed and squared prior to nailing off all the bracing. All joints in the top plates between walls should be joined using steel frame joining plates, and nailed with spiral shank nails. item No: 30. All steel bracing should be continuous from top to bottom plates. at an angle of 45 degrees, and have two nails per stud.

* The internal or drying room rear wall is constructed first. The layout is given on sheet No: 8. Note that the top plate extends over the screen walls, and the bottom plate is shorter to facilitate the access doors. The top plate is fastened to the bearer on the top of the screen walls, and requires 25mm packing. Detail is given on sheet No: 9.

* The centre wall should be constructed next. Posts should be prepared with bolt holes in the bottom to match post shoes, and a saddle cut in the top to take centre beam which runs the length of the drying room. See Sheet No: 10. The posts can be positioned in their shoes, followed by the central beam which ties in to the internal rear wall, and is fastened with 2 bolts, item No: 35. The centre wall can be temporarily braced in position at the southern end, until rafters are attached. Coach screws, item No: 36, are used to fasten posts in shoes at the bottom of the posts. Similarly screws are used to fasten the posts to the centre beam at the top. At this stage the centre hob can be constructed and sheeted with 19mm ply as shown on sheet No: 6. The bearers for this hob are bolted to the posts, item No: 35, and fastened to the floor joist under the internal end wall, (See Sheet No: 5).

* The rafters of the internal roof should be positioned next. Each rafter is butt joined to the central beam and is fastened to the bearer on the top of the block wall, as shown on sheet No: 9. Note that the rafters are rebated to fit the bearer, and trimmers are fitted between each rafter. At the centre beam, a joist hanger is used to support the join, (See sheet No: 11).

* The southern wall should be constructed next. The layout of the wall is shown on sheet No: 12. Note that the wall has a plate running across its width above the door. Also, the studs should be cut with a 15 degree angle on the top to fit the slope of the roof as shown on Sheet No: 10. Plywood sheet, item no: 20 and 21 is used to clad both sides of the wall, with the treated plywood used on the exterior. The plywood should only be fixed when the wall is positioned and certain to be plumb and square. The wall should also be insulated with polystyrene foam, item No: 52. This is cut to size to fit between the studs in the wall and is sandwiched between the plywood cladding.

- * The centre baffle should be constructed next. The studs are positioned at 621mm centres along the top plate and 600mm centres along the bottom plate, to compensate for the 15 degree slope in the roof. Note that the tallest stud can be cut to length which is given on the plan, and each stud is 161mm shorter than its predecessor. The wall is fastened to the centre beam of the drying room and to the southern wall.
- * On completion of the baffle wall the fan wall should be built. The layout is given on sheet No: 10. Note that this wall and the baffle wall are sheeted one side with 7mm ply after the timber framing is complete.
- * At this stage the drying room roof and end wall should be clad with corrugated iron sheet, item No: 54. The iron can be screwed directly to the rafters and stud wall using roofing screws, item No: 37.
- * The northern end wall is constructed next. Studs should be cut with 30 degree angles on the top to compensate for slopes on the roof and the wall. The wall can then be positioned and temporarily braced awaiting the side walls to be fitted.
- * The side walls are to be constructed next. The layout is given on sheet No: 14. The plates can be built from shorter lengths by cutting half lapped joints and fastening the joints with frame joiner plates. Studs are marked at 600mm centres on the bottom plate and 621mm centres on the top plate to compensate for the roof slope, and each stud is 161mm shorter than its predecessor. Note the positions of plate joiners between stud and plates at bracing points on the side walls. These are required to complete the tie of the roof to the footing. When all the exterior walls are in position, the frame should be plumbed and squared and all braces nailed off.
- * The final stage of frame construction is building the roof. The rafters can either be continuous over two spans, or if 6m lengths are unavailable, they can be butt joined over the centre baffle and fan walls. Triple grip joiners, item No: 31, in left and right hand pairs are used to fasten each rafter to the top plates of the side and centre walls. Having positioned all rafters, trimmers are cut and fitted between each rafter over the side and centre walls as shown on sheet No: 15. A flat iron brace, item no: 27, is used to brace the building to maintain squareness. This brace runs across each diagonal of the roof and ties down on to the top plates of the side walls. Two nails should be used in each rafter, and the brace should be pulled as tight as possible across the roof.
- * To complete the timber construction the internal access doors and the main doors need to be built. The main doors in the southern wall are constructed from a light timber frame sheeted both sides with 7mm ply and filled with styrofoam in the same way as the southern wall. The detail is given on sheet No: 16. The external ply sheeting should be treated to resist decay. A door stop is provided by cutting the external sheet to provide a 20 mm lap over the centre post which is reinforced with a metal internal angle, item No: 51. This angle can be the same material used for bracing the wall frames. The doors are sealed with a door sealing strip along each side and the top. The doors should be hung with a 300mm steel gate hinge and pad bolts used as door latches, item No: 46 & 47. Similar to the main doors, the internal doors are constructed from a light timber frame and sheeted one side with 7mm ply the main doors. They are hung on 100mm butt hinges and pad bolts used as a latch, item No: 48 & 49.

* Having completed all construction excluding fitting the exterior plastic cladding, all surfaces exposed to the sun should be primed and painted with an exterior grade acrylic paint. The final colour should be matt black.

* The exterior polycarbonate plastic cladding is screwed to the frame using galvanised roofing screws 75mm long, item No: 37. The holes in the cladding should be 1mm larger than the screws to allow for a small amount of expansion in the sheet, and the screws should be fitted with a neoprene washer to seal the hole from water and air leakage. All lapped joints in the sheets should be sealed with clear silicone sealant, item No: 53. All joints at corners should be sealed with impregnated, corrugated foam strip, item No: 25, see sheet No: 15 section C - C'. All corners should be further sealed with 100mm X 100mm galvanised iron flashing, item No: 45, excluding the corner between the roof and north wall. This corner should allow run off from the roof, and the sheet on the roof should be extended over the north wall to provide an eave to allow drainage of rain water away from the kiln.

Installation of Polycarbonate sheets

Handling and Storage

- 1) Store the sheets on a flat surface.
- 2) Keep away from direct sunlight during storage.
- 3) Avoid contact with chemicals, paints, adhesives or any other synthetic materials which are incompatible with polycarbonate.

Method of Installation

Always install the material with its sticker. "THIS SIDE UP" facing the sunlight. This is the side that has been treated with a protective coating against radiation.

Purlin Spacing

The spacing should generally be as recommended in the table. For sheets exposed to winds or other high loading, these distances should be reduced. When using longitudinal overlap fasteners, spacing may be increased up to 1200 millimetres.

Roof Pitch

It is recommended that roof pitch should be a minimum of 10 degrees. If smaller pitches are necessary, special flushing or sealing should be used.

Cutting

Polycarbonate plastic cladding can be cut with shears, fine tooth saw blades or fine circular blade saws.

Drilling

Polycarbonate plastic cladding can be drilled using all kinds of bits. Screw holes should exceed screw diameter by at least 2 mm to compensate for material expansion.

Fastening and Fixing

Use only rust-free fasteners to fix the plastic cladding in place. Washers should be made of neoprene rubbers compatible with polycarbonate. Take care not to use soft P.V.C. washers or other materials that are incompatible with P.C. sheets. Depending on wind exposure, the plastic cladding should be fastened at every third or fourth corrugation. Sheet edges at ridge and gutter should always be fastened at each second corrugation.

Roof fastening

When fastening polycarbonate plastic cladding to roofing, it is recommended:

Iron wave/Industrial wave - Fasten the sheets through the "crests" of the sheets, using matching curved washers. Take care not to put the sheets under any stress in the fastening points.

Wall fastening

When mounting polycarbonate plastic cladding sheets on walls, screws may be fixed in the valleys even in iron wave sheets. Purlin spacing can be higher than in roofing applications.

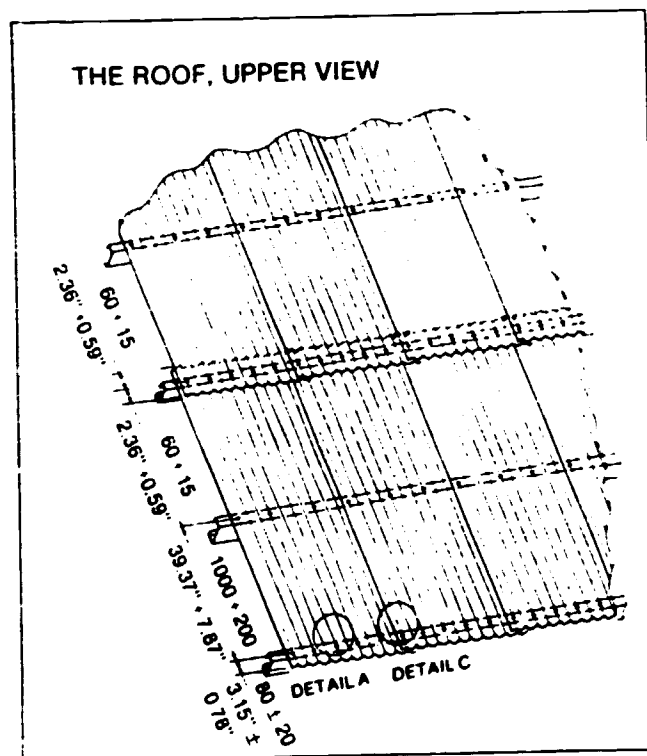

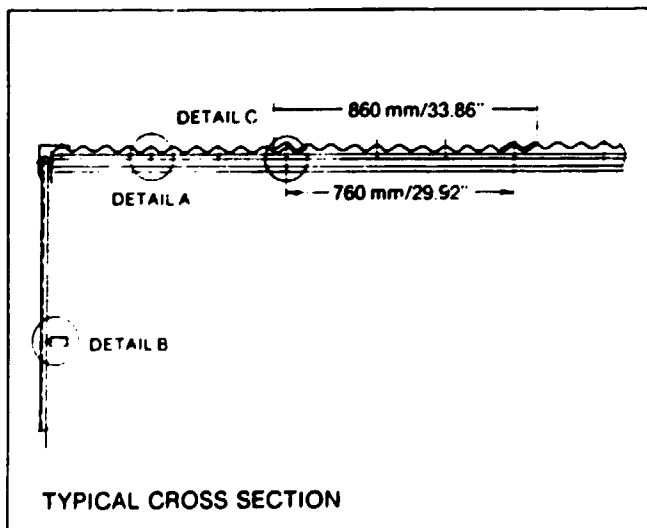
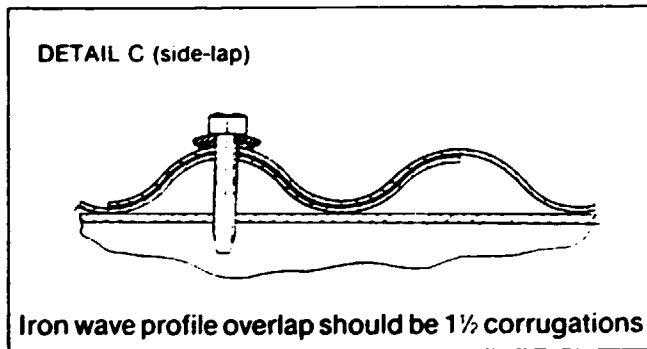
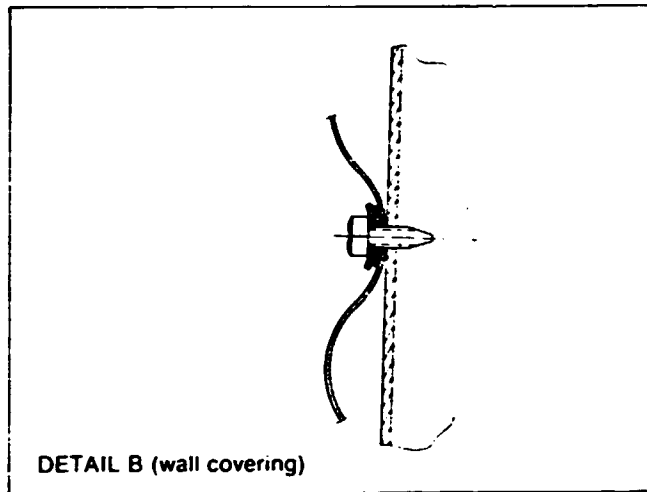
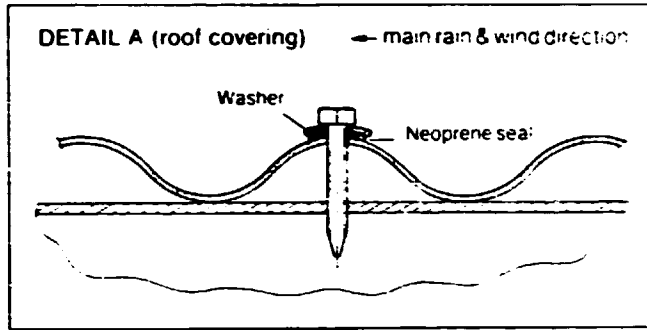

Roofing Fastening

When using the GRECA profile (see detail D) - Fasten the sheets in the "valleys" and tighten the screws with flat washers to avoid leakage.

Overlapping

Also when using the GRECA profile - When overlap fasteners are used, only one corrugation overlap is recommended. Sheet end should overlap for about 120 millimetres (see details E & F). The upper sheet in the overlap should be the upwind sheet.

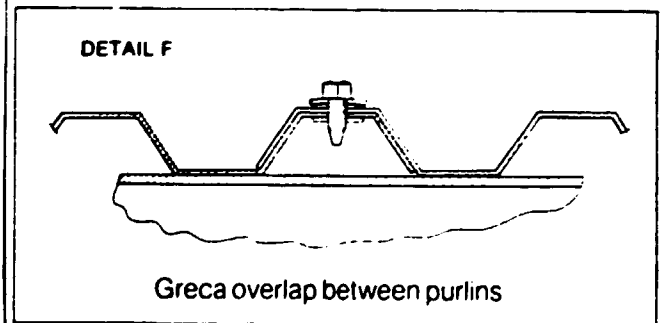
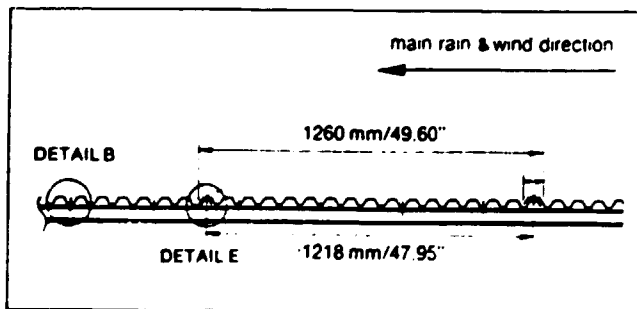
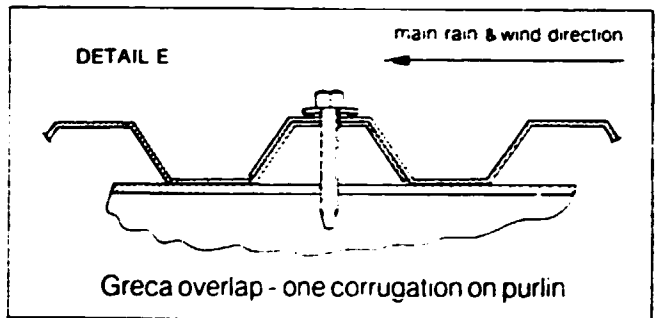
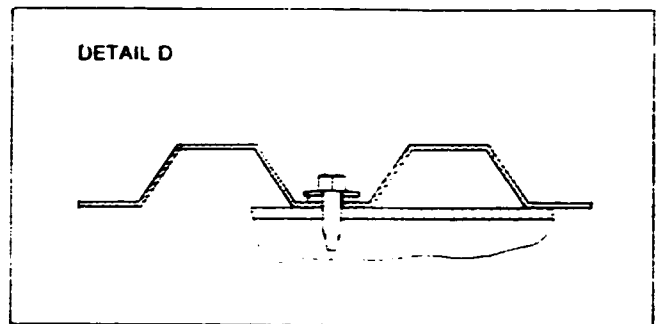
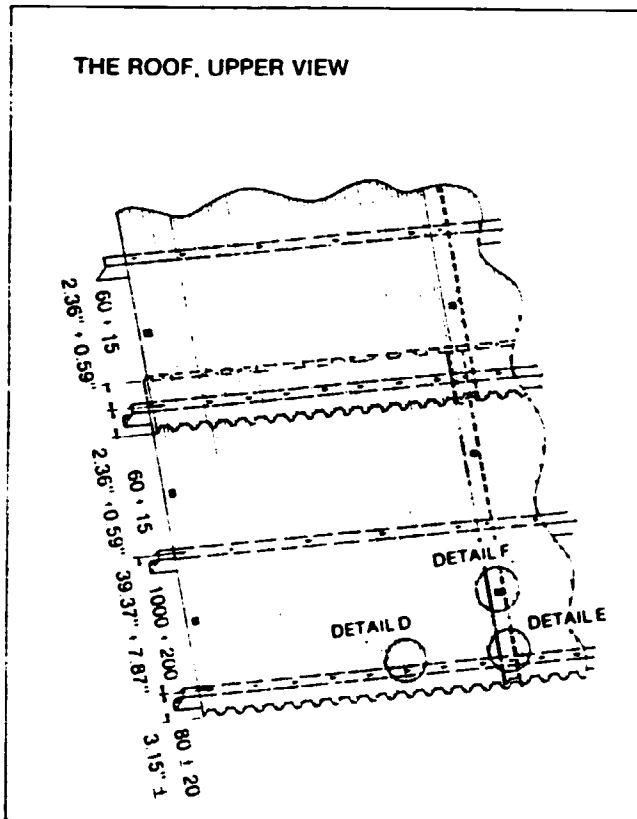

Installation of fan and motor

* The fan and motor can be purchased in combination from suppliers of fan equipment. The fan and motor used should provide a 1 meter per second air velocity through the stack at an estimated static pressure of 6mm water gauge. This corresponds to an air volume of 7 to 8 cubic meters per second through the fan. A recommended combination is a 1.1 kW Motor, with a 960mm diameter fan, with 8 wings at a pitch of 16 degrees, rotating at 700 rpm.

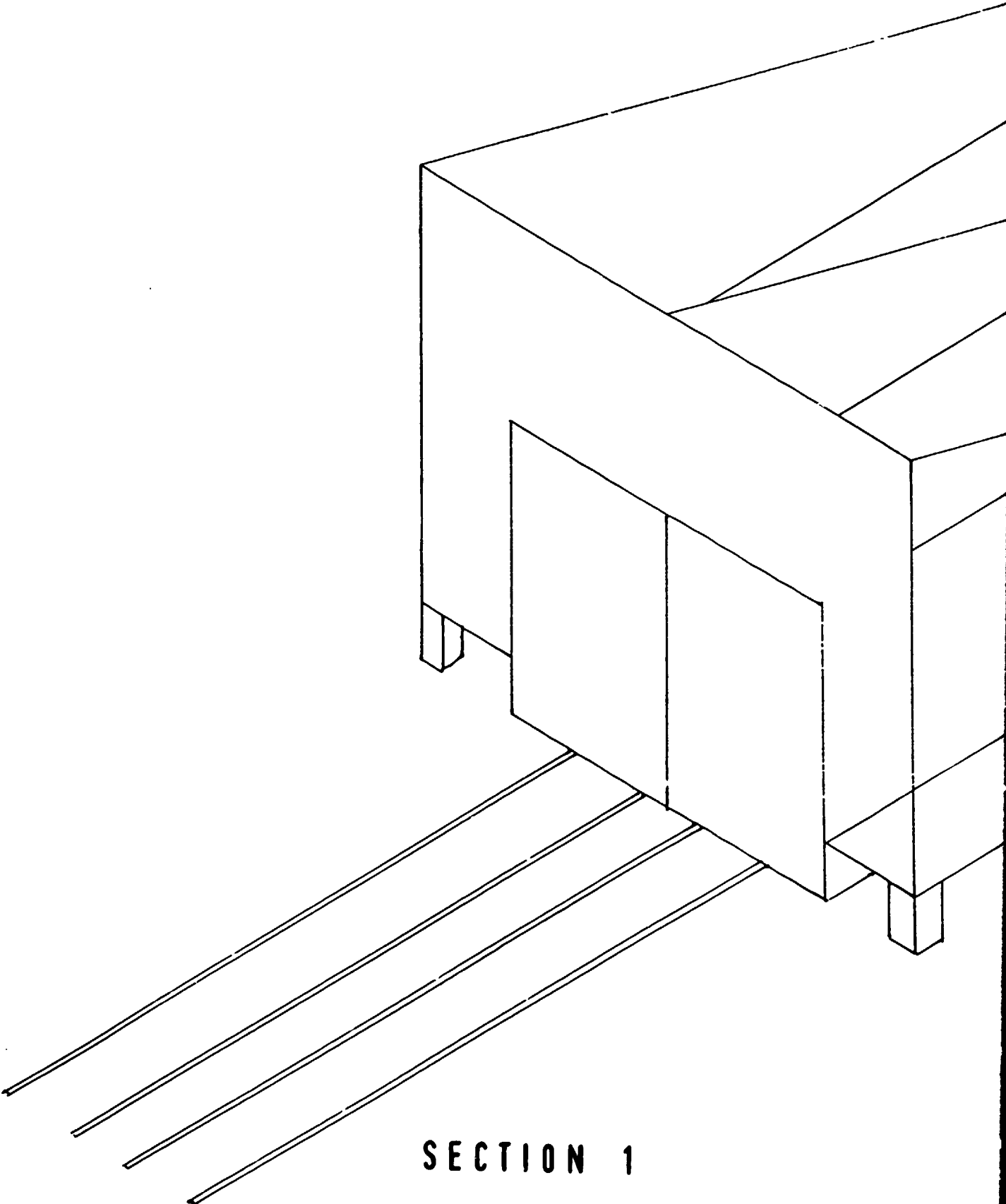

SECTION 1

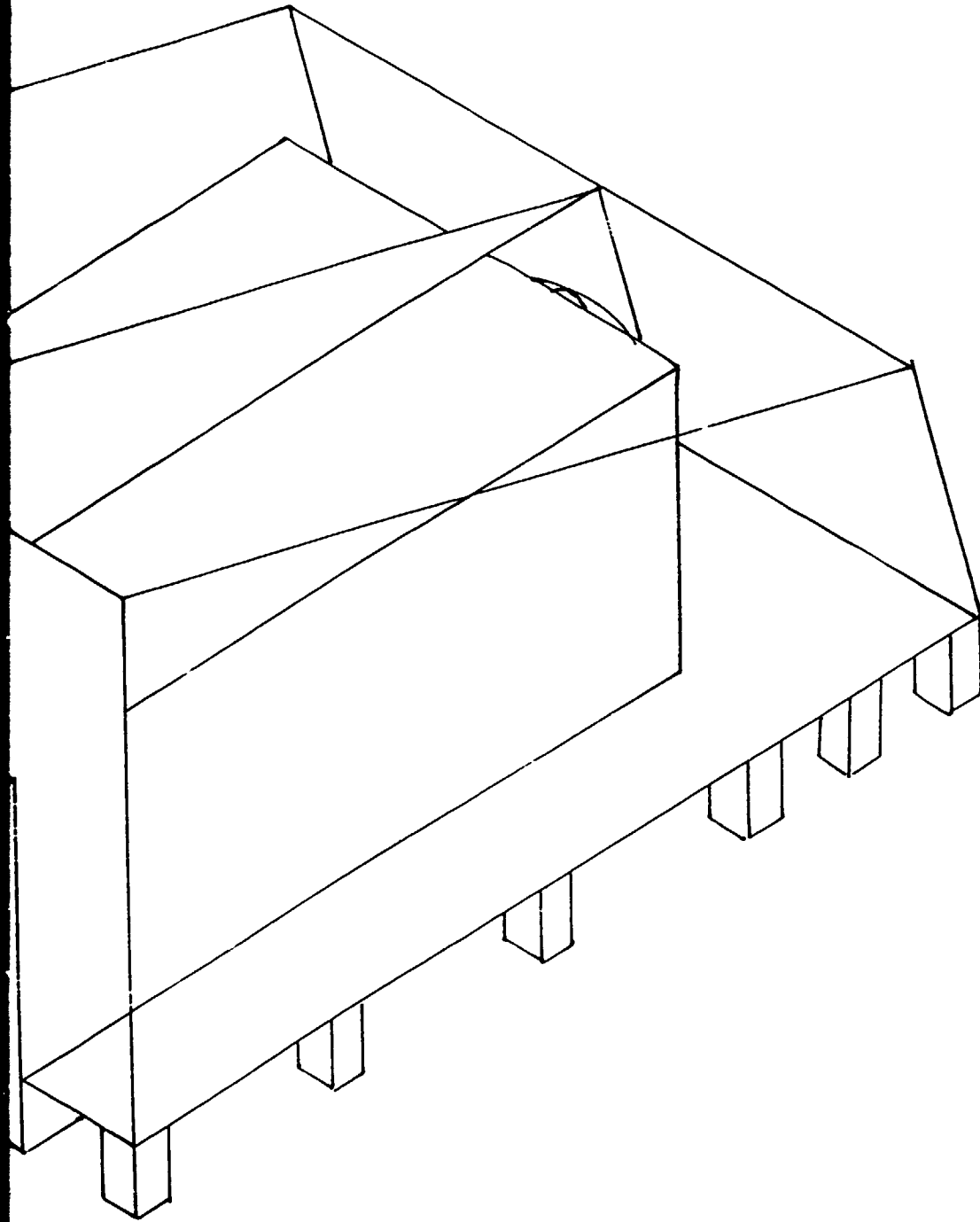

SECTION 2

Projection
Scale Kluw
Sheet No: 1
SCALE 1:50

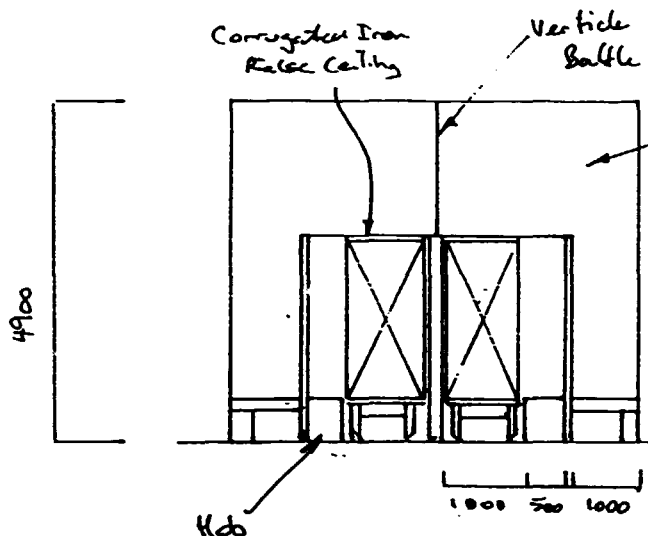

SOUTHERN ELEVATION

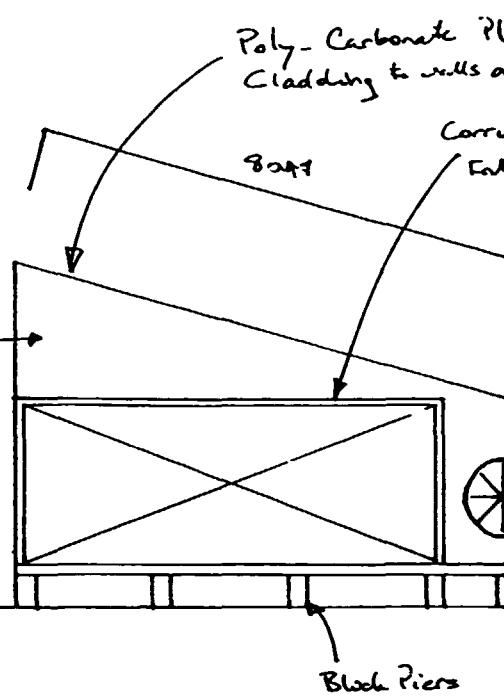

EASTERN ELEVATION

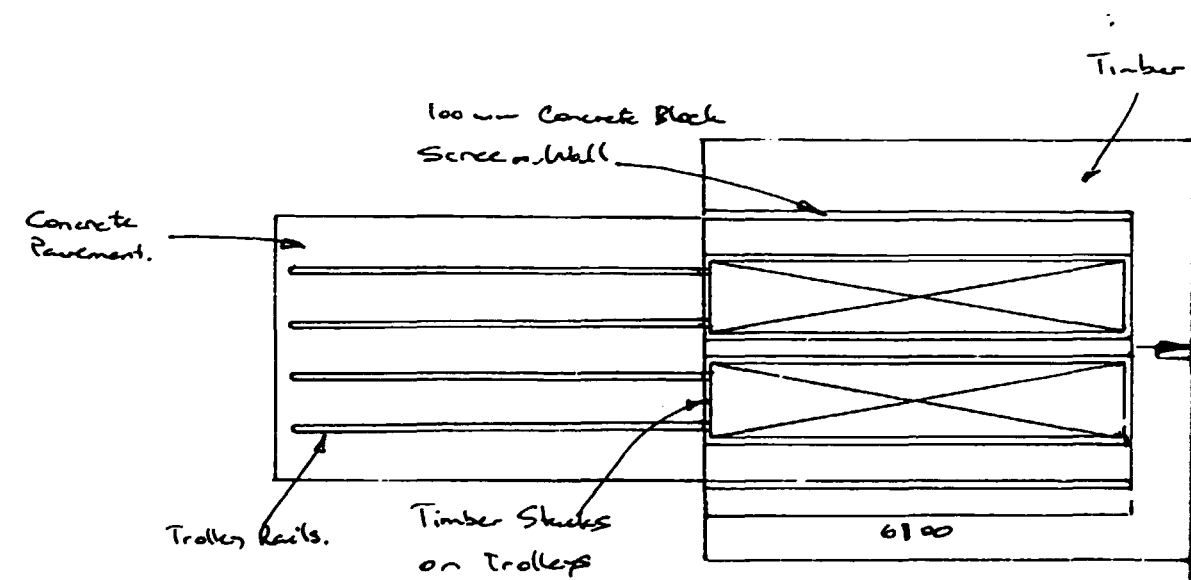

SECTION 1

8300

PLAN

Poly-Carbonate Plastic Cladding to walls and roof

Corrugated Iron false ceiling

Reversible fan 1.1m diameter 1.5 kW motor

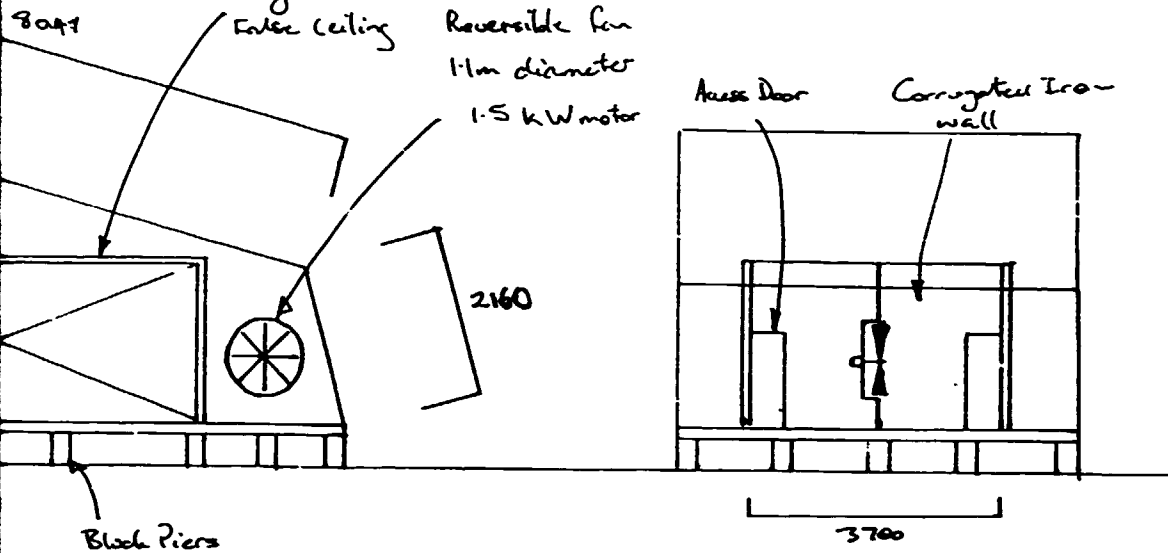

Block Piers

Access Door Corrugated Iron wall

3700

AN ELEVATION

• NORTHERN ELEVATION.

Timber Floor

Fan Wall

5900

Poly-Carbonate Plastic Cladding to walls and roof.

300

SECTION 2

PLAN AND PROFILES
SOLAR KILN
Sheet No. 2.
SCALE 1:100

5.5

8.3

SECTION 1

3

SITE PLAN

SOLAR KILN.
TAGS
N
Sheet No: 3
Scale 1:50

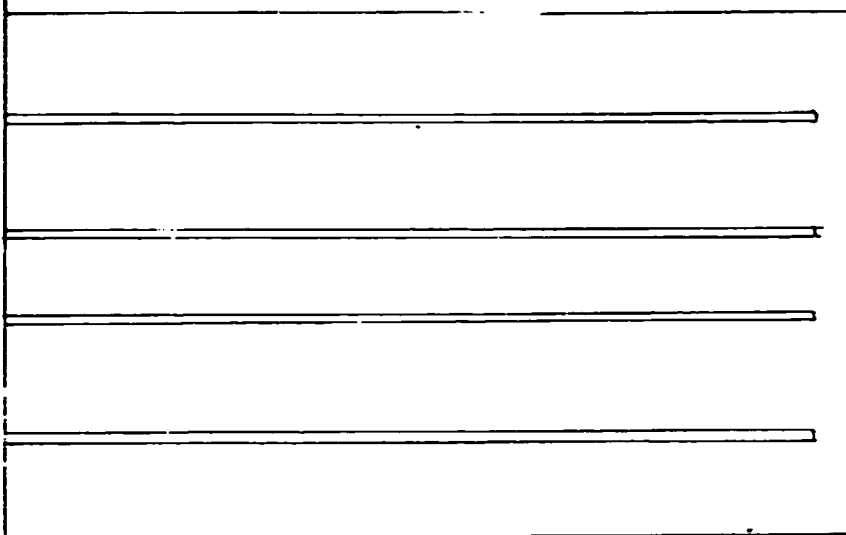

6.2

SECTION 2

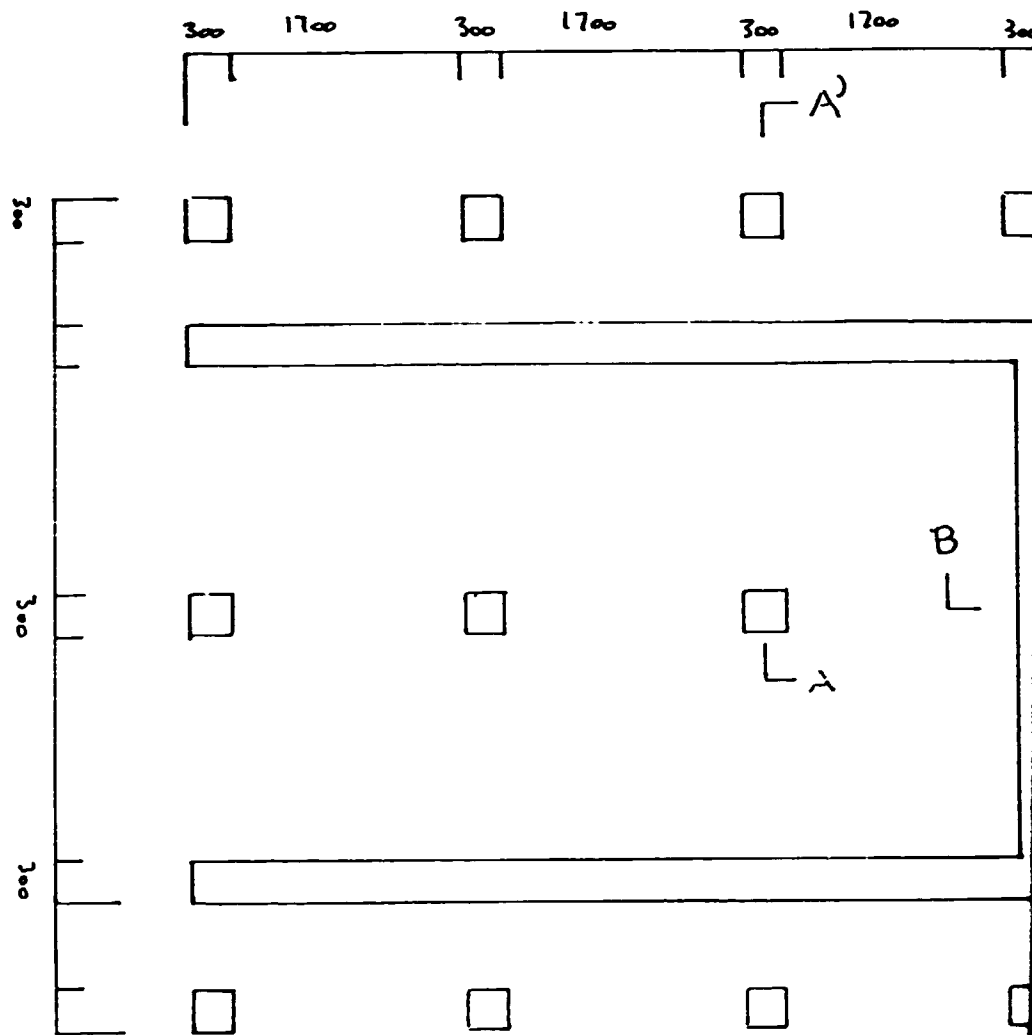

SECTION 1

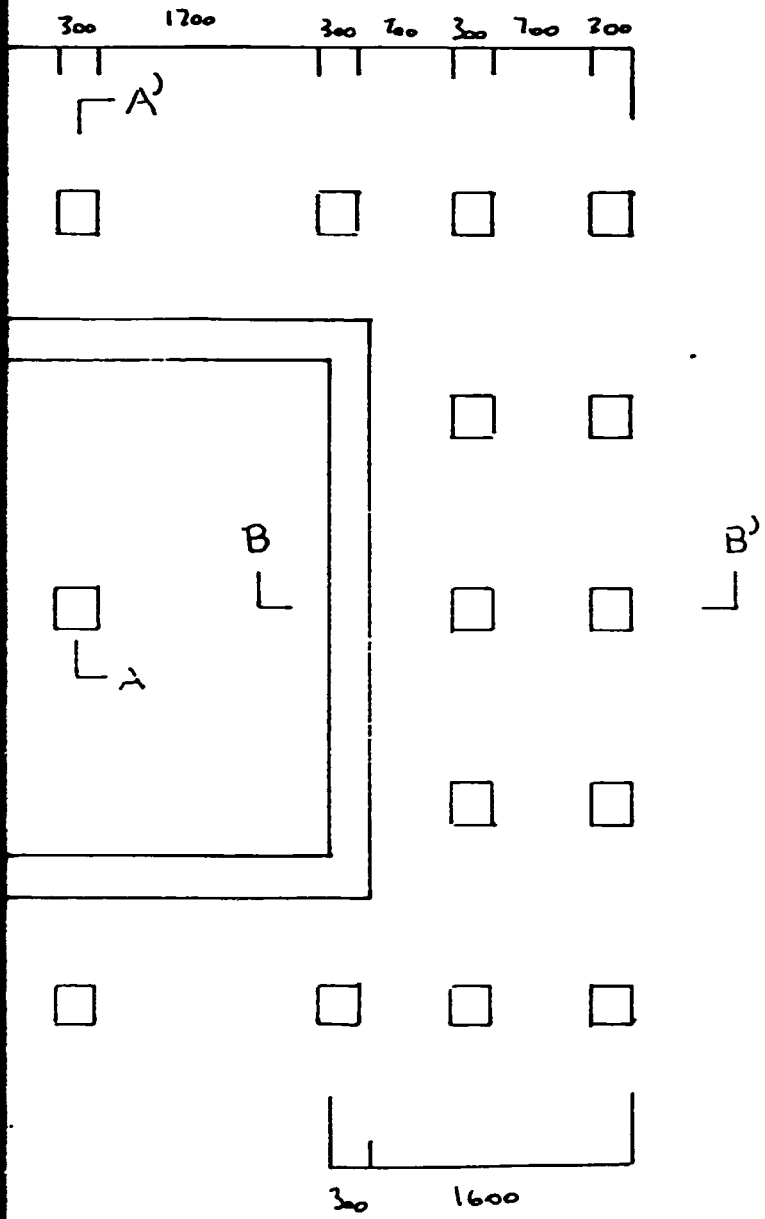

SECTION 2

FOUNDATIONS
Solar Kiln Sheet No: 4 Scale 1:50

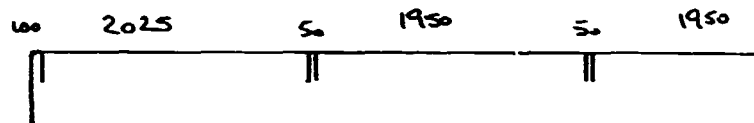

A'

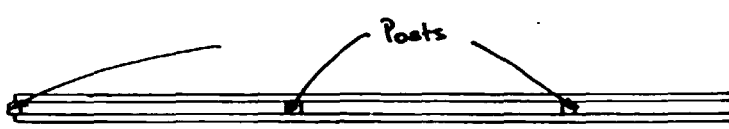
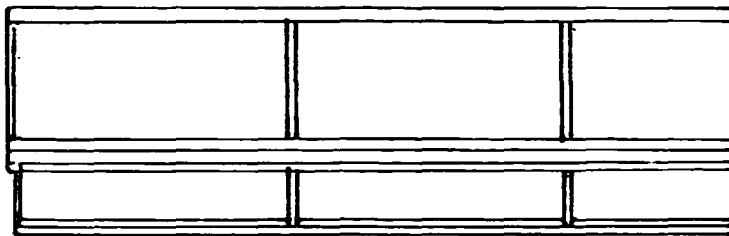

A

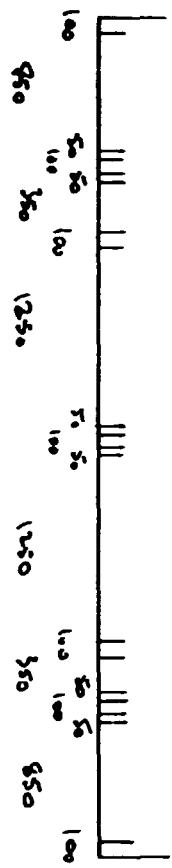
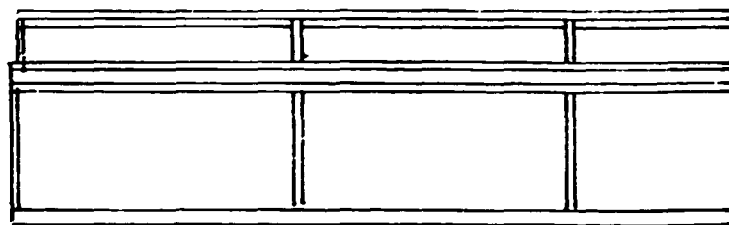

SECTION 1

50 1950 50 925 100 1000 100

A'

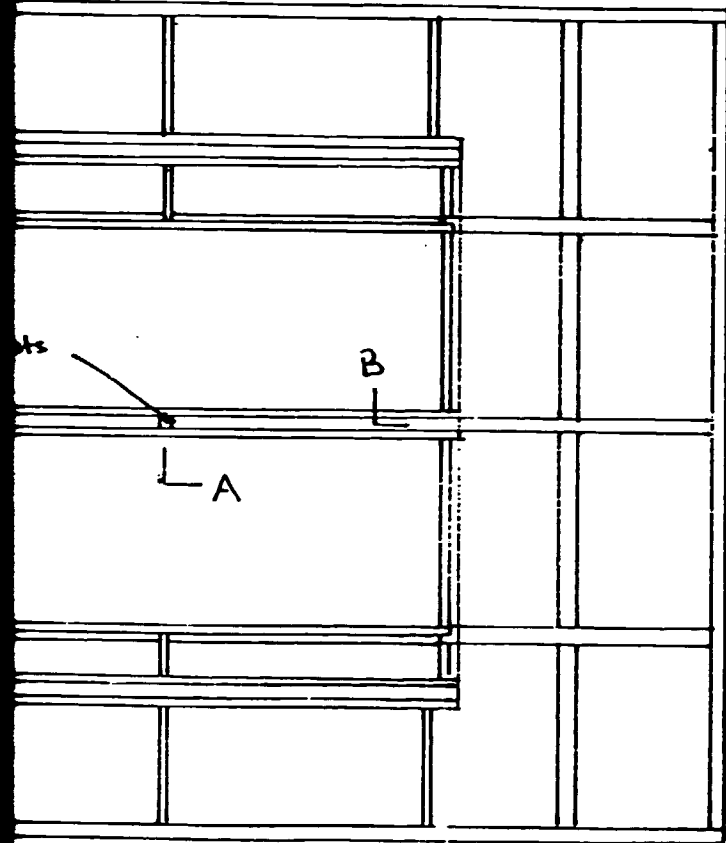

B'

100 1900

SUB-FLOOR

Solar Kiln

Sheet No: 5

SCALE 1:50

SECTION 2

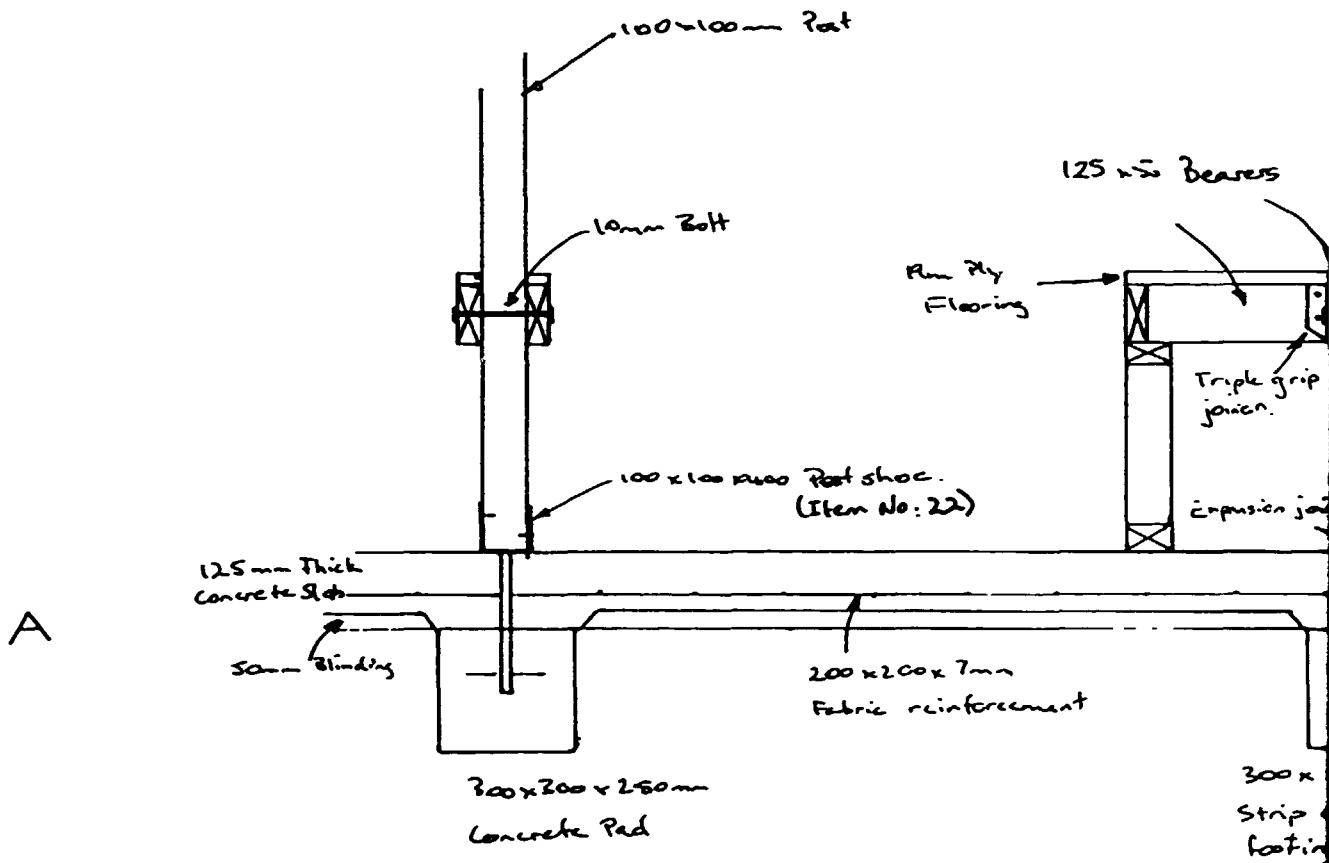

SECTION 1

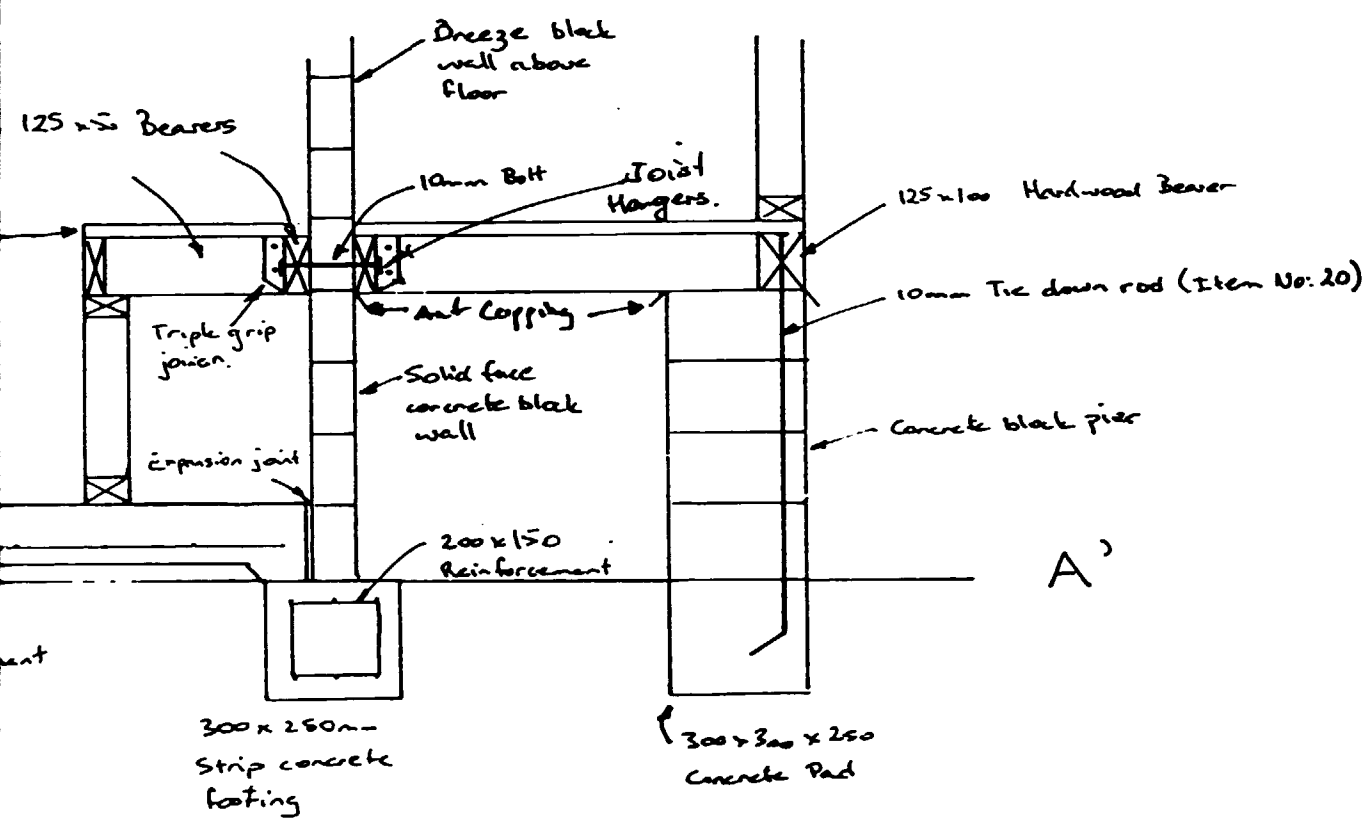

SECTION 2

DETAIL # 1 SECTION A-A'
SOLAR KILN
Sheet No: 6
SCALE 1:15

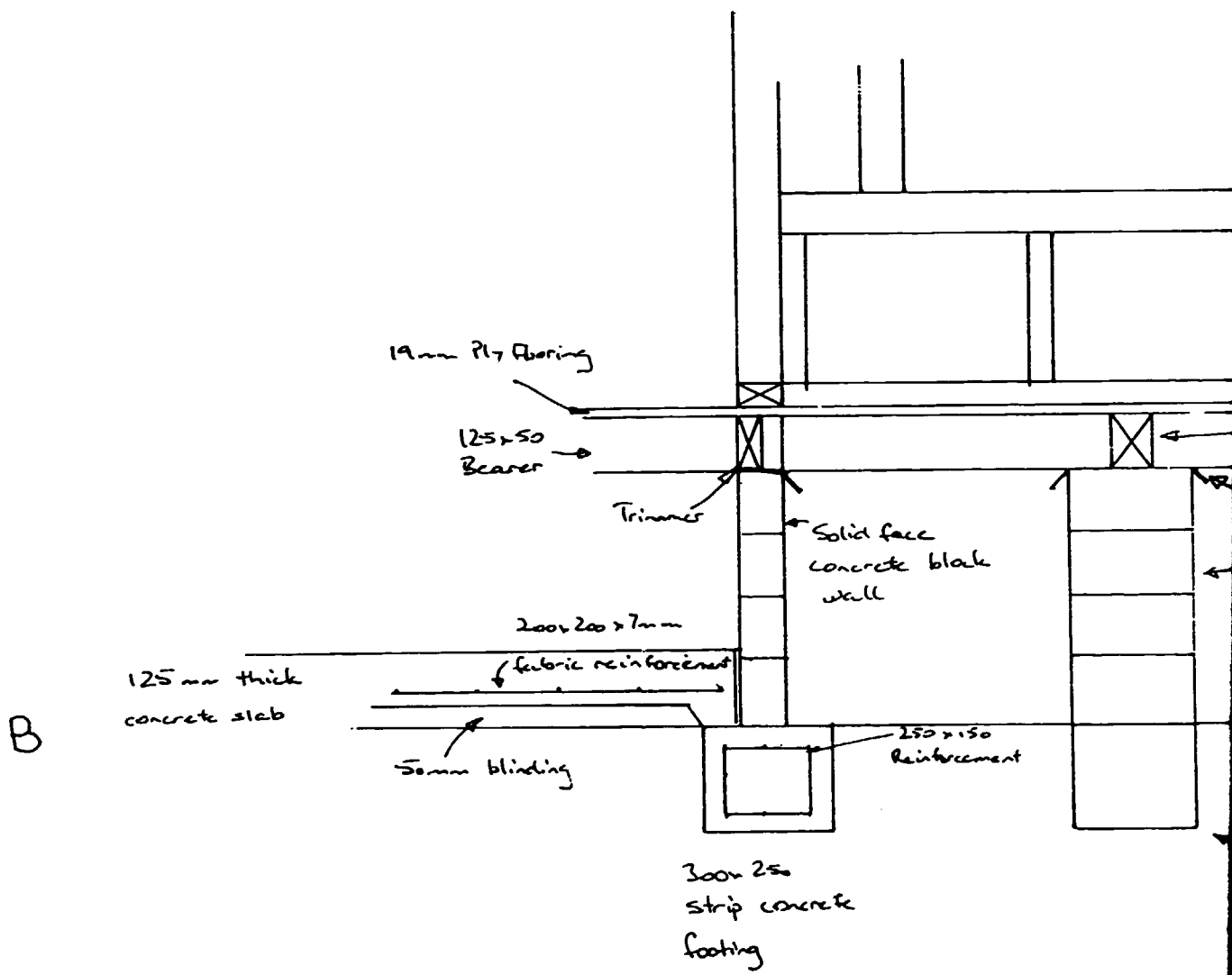

SECTION 1

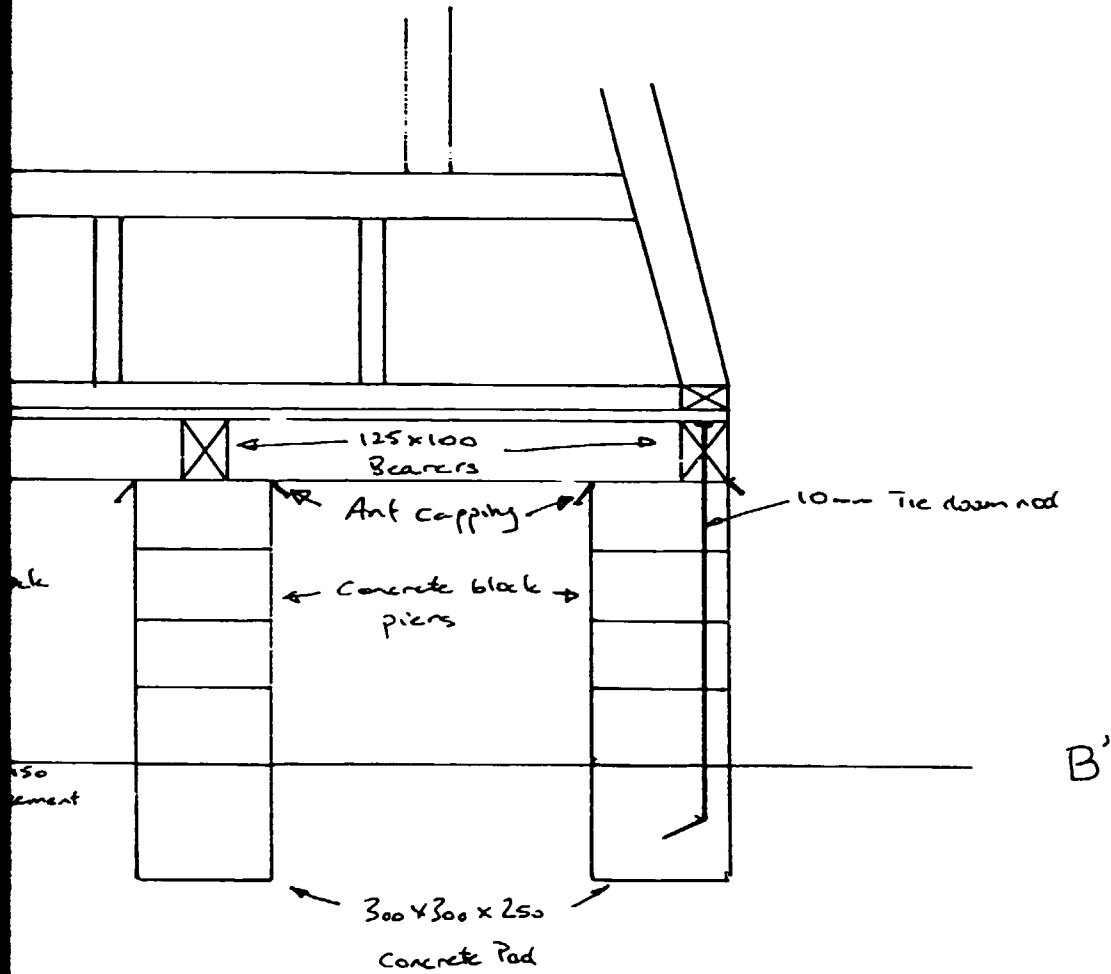

SECTION 2

DETAIL # 2 SECTION B-B'
SOLAR KILN
SHEET NO: 7
SCALE 1:15

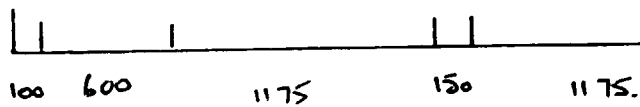
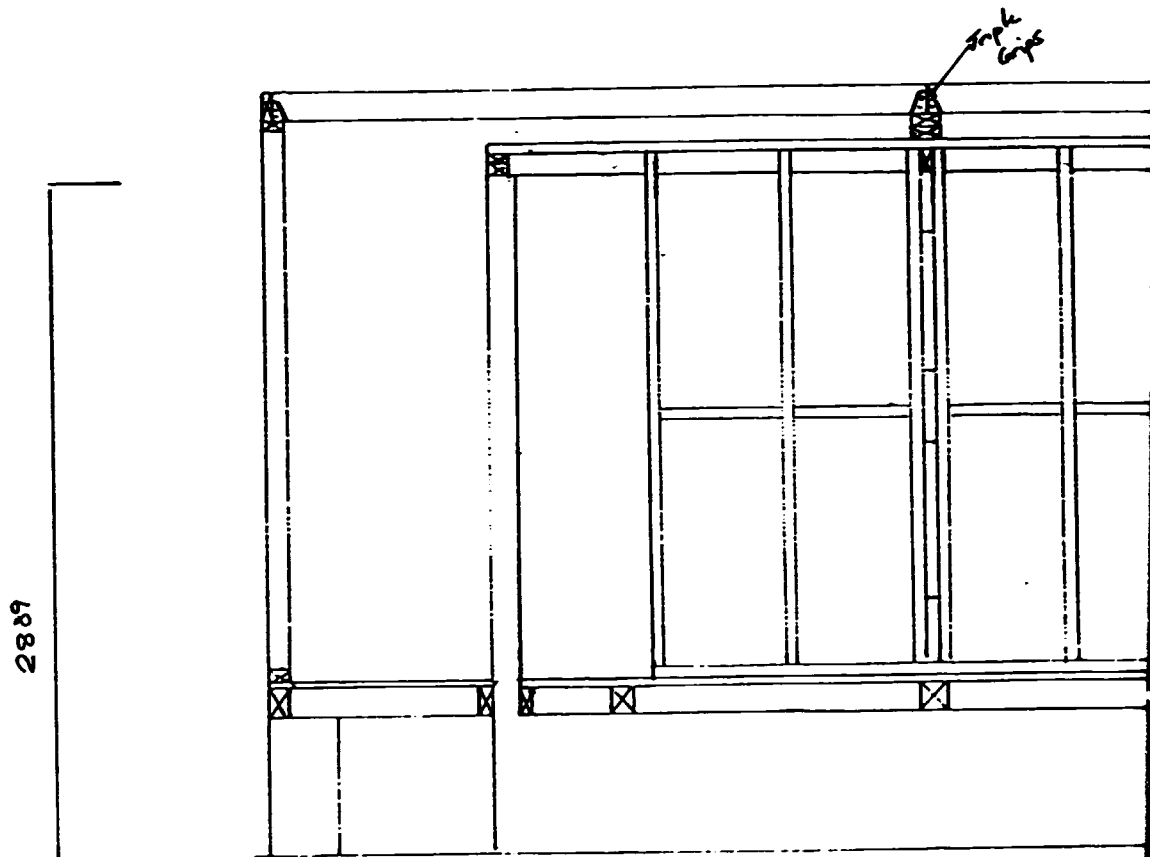

SECTION 1

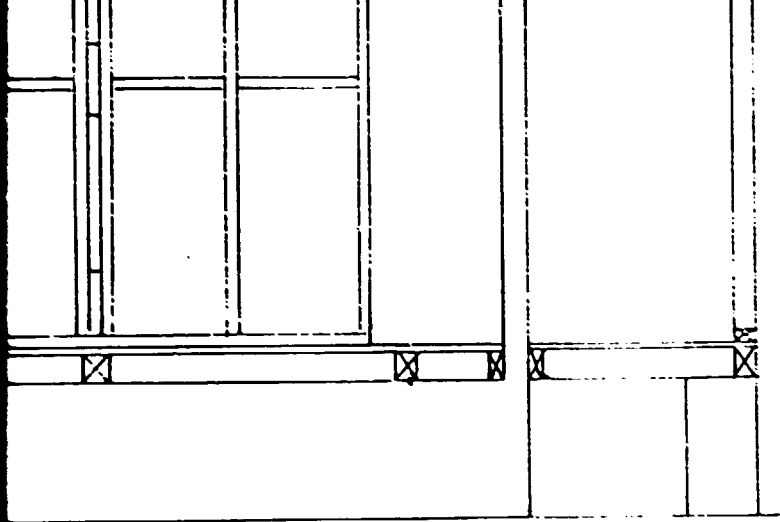

2170
12580
P

150 1175 600 100

SECTION 2

INTERNAL END WALL
SOLAR KILN
Sheet No: 8
SCALE 1:30.

67

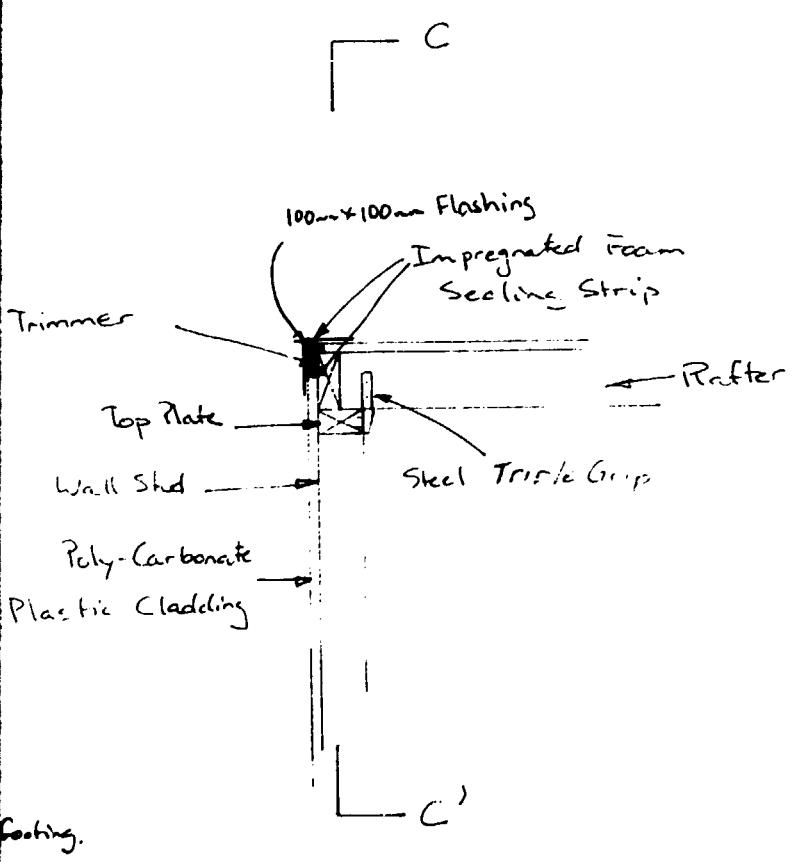

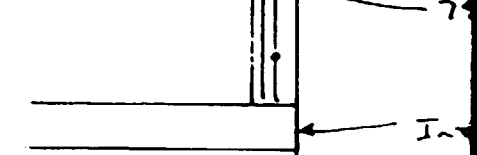

PLAN

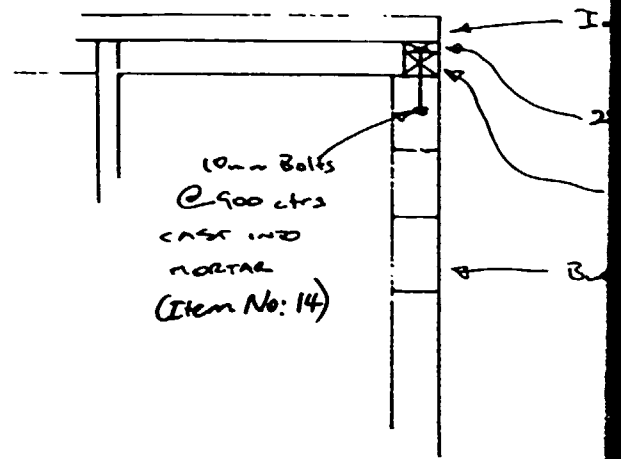

SECTION

SECTION 1

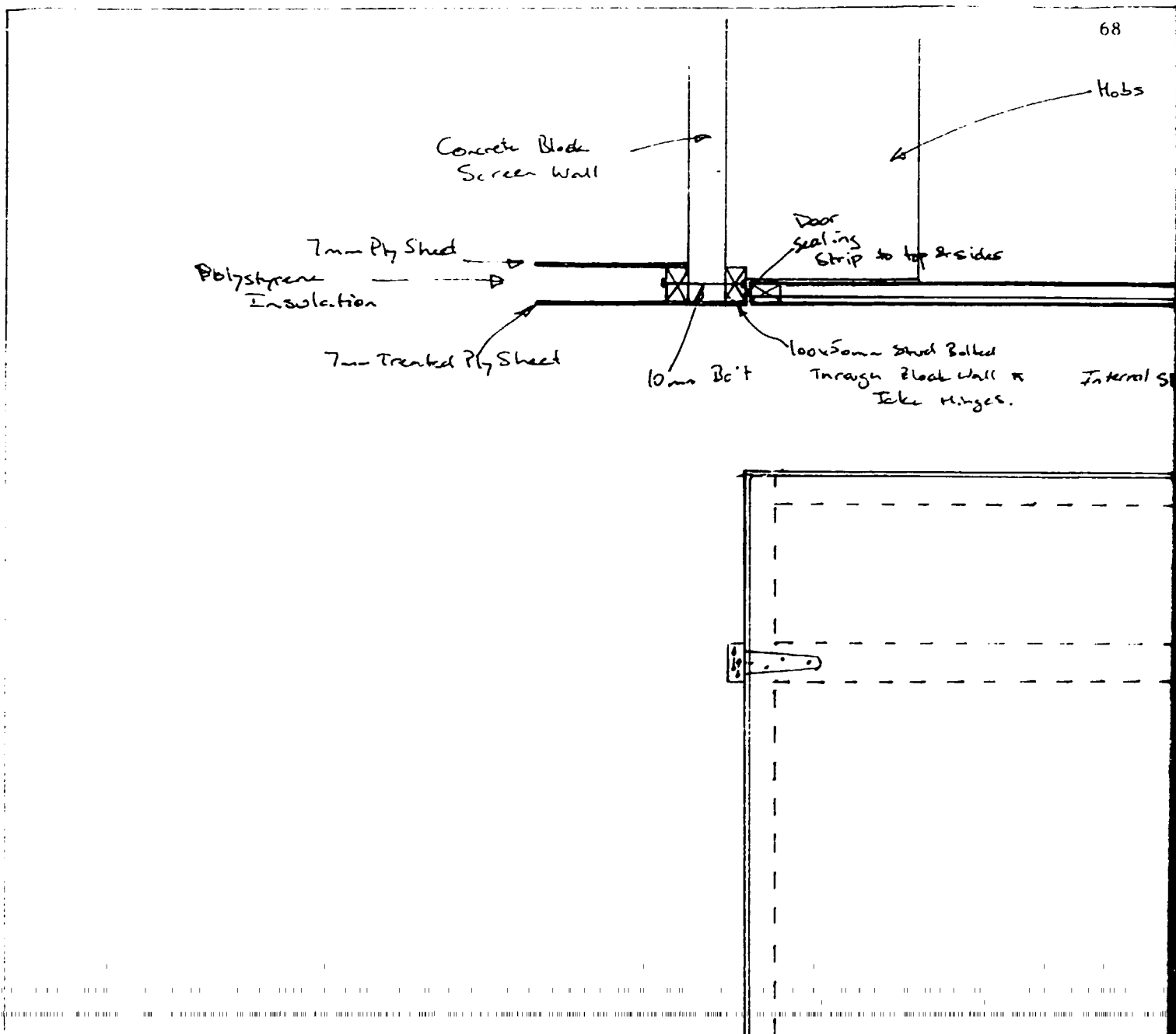

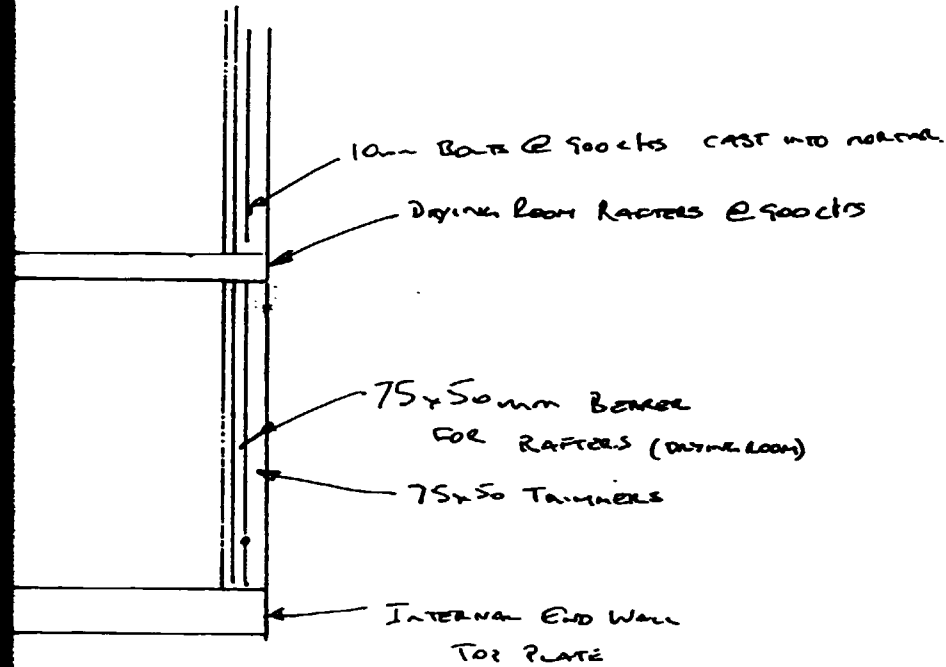

LAN

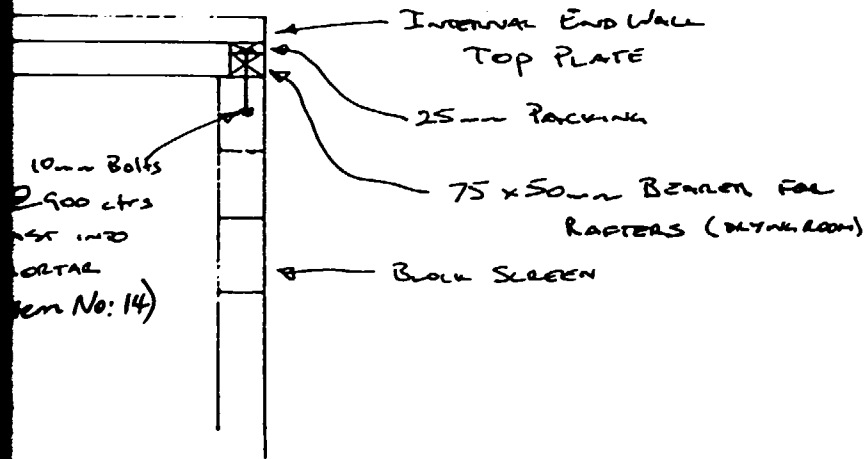

SECTION

SECTION 2

DETAIL #4 SECTION G-G'

SOLAR KILN

SHEET NO: 9

SCALE 1:15

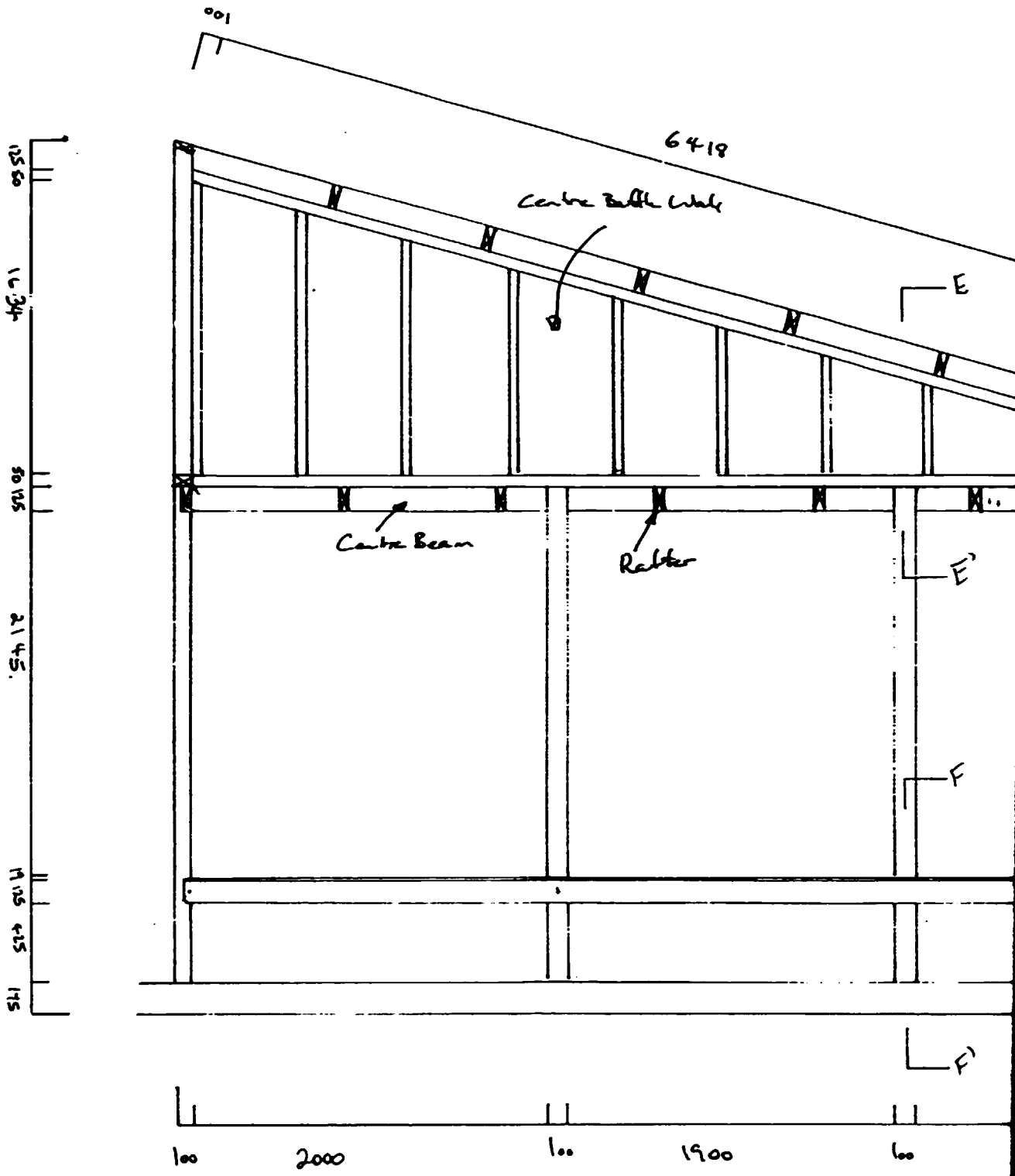

SECTION 1

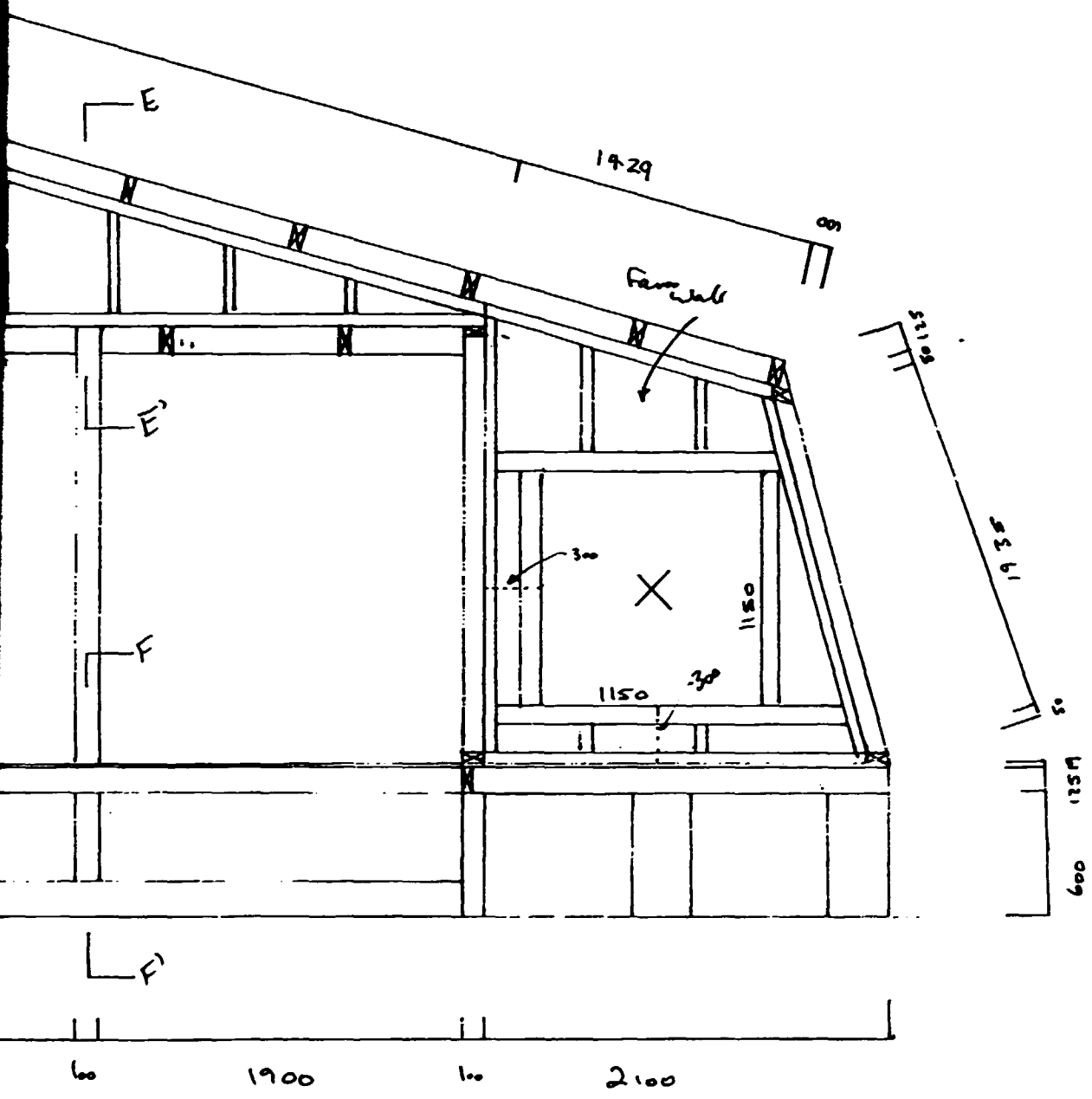

SECTION 2

CENTRE WALL FRAME
SOLAR KILN
Sheet No: 10
SCALE 1:30

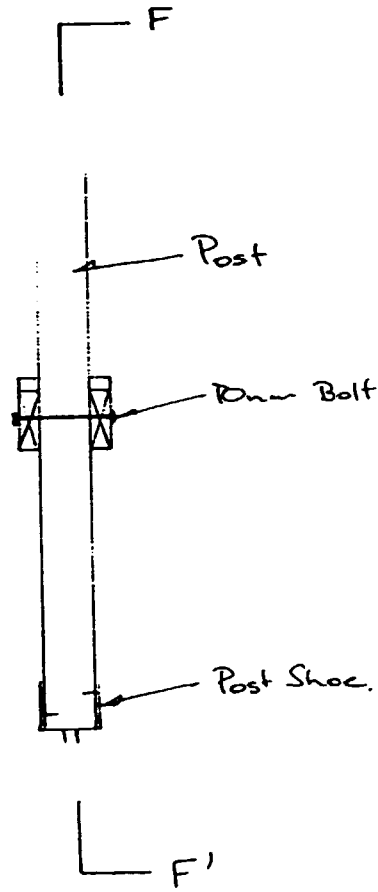

Trimmer

Bearer

SECTION 1

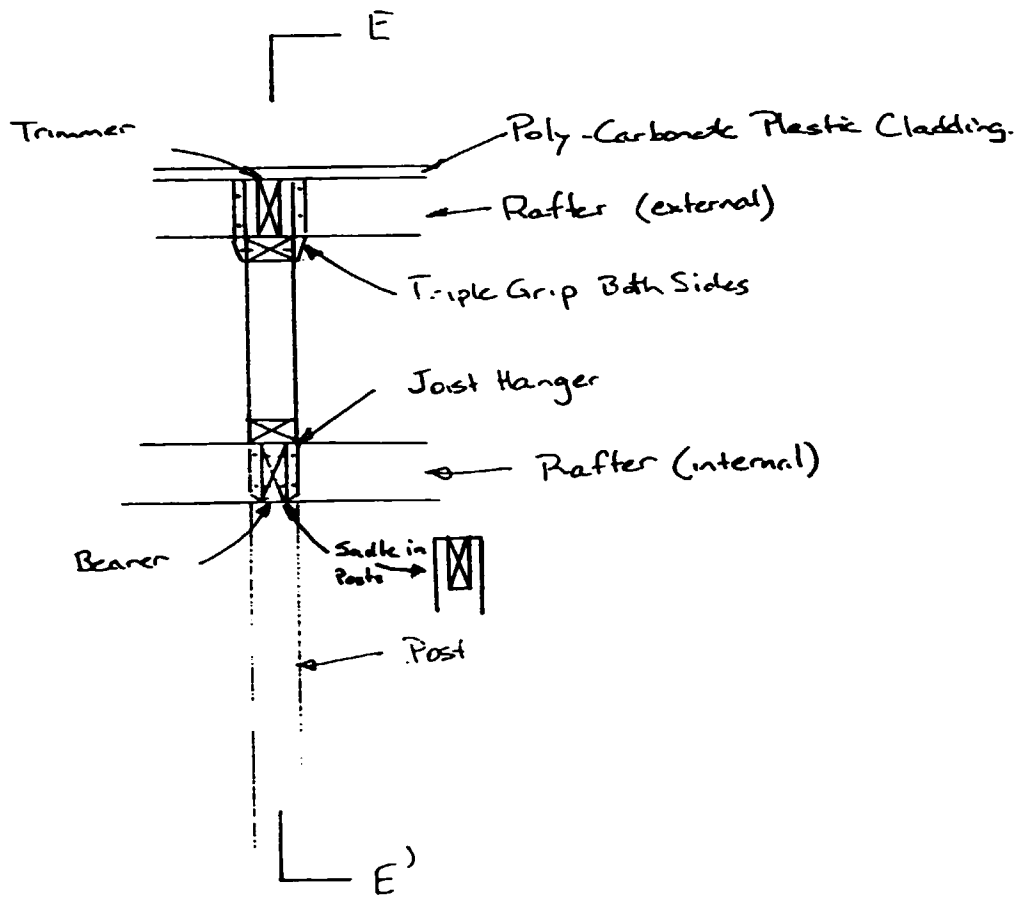

DETAIL # 3 SECTIONS E-E' & F-F'

SOLAR KILN

Sheet No: 11

Scale 1:15

SECTION 2

Centre Wall Baffle
Rafter

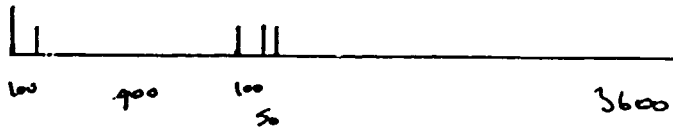
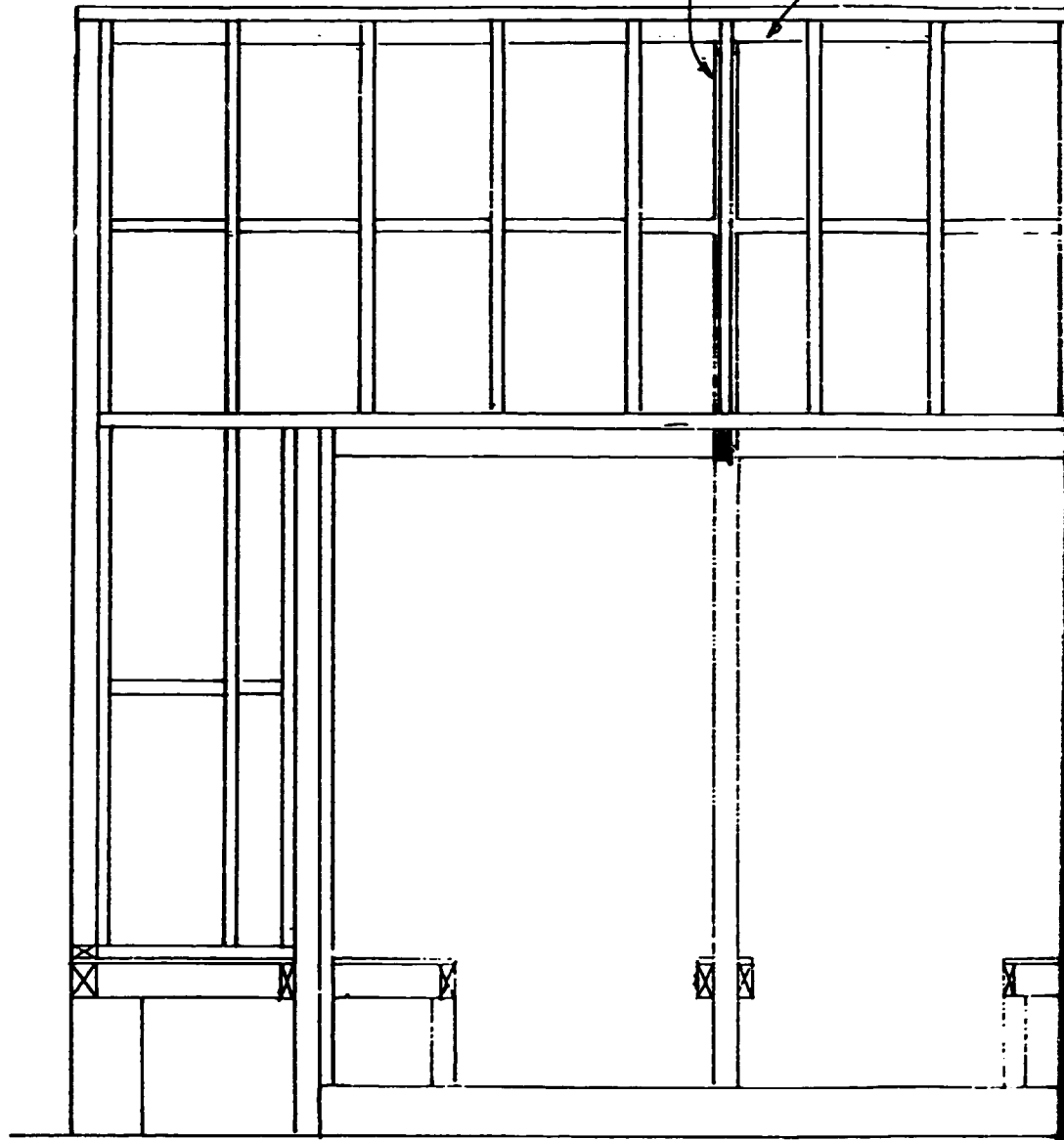

SECTION 1

Centre Wall Baffle
Rafter

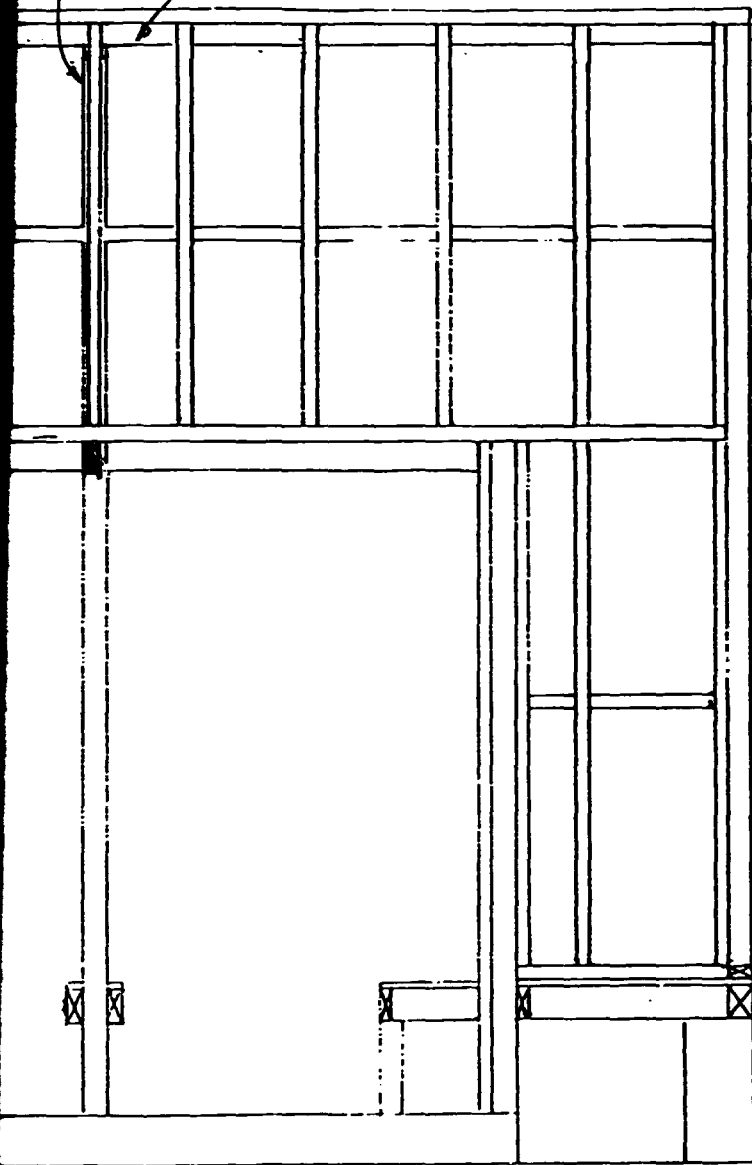

50
1786
50
115
50
2145
50
119
600

3600

50

100

900

130

SECTION 2

Southern End Wall

Solar Kiln

Sheet No: 12.

SCALE 1:30

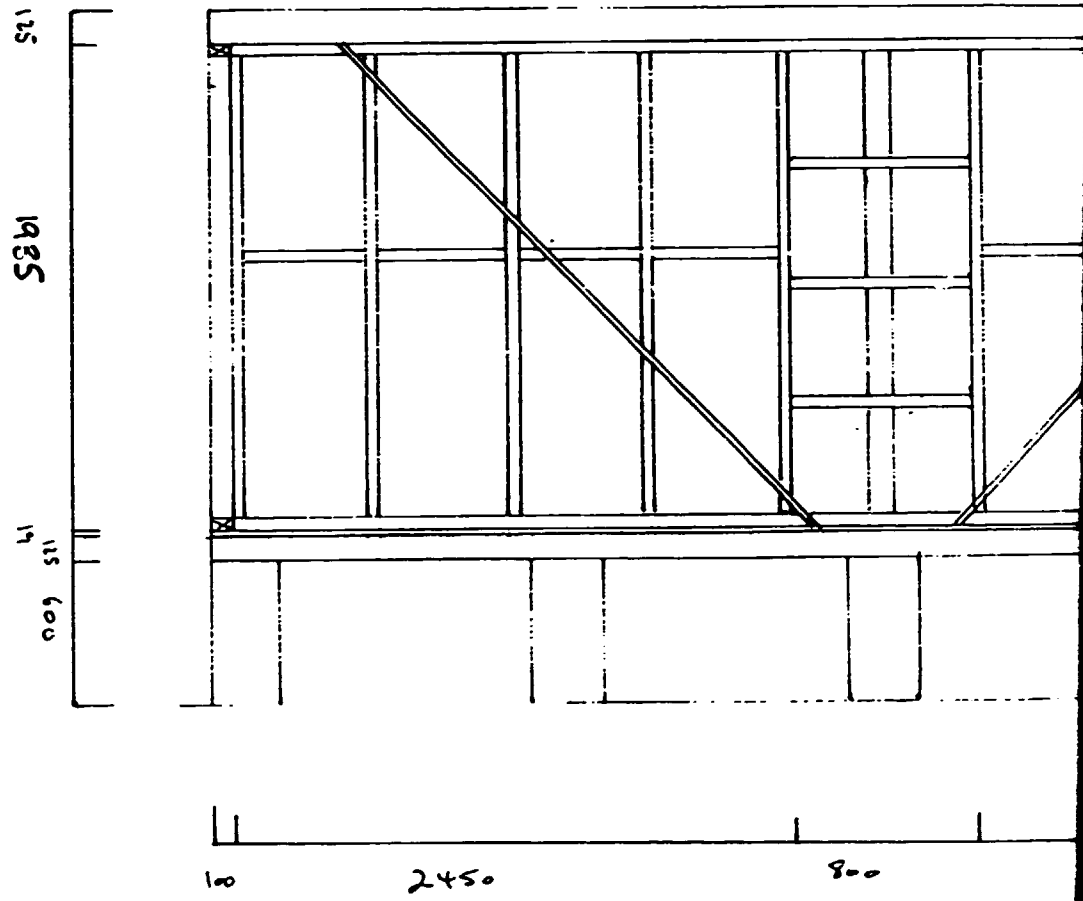

SECTION 1

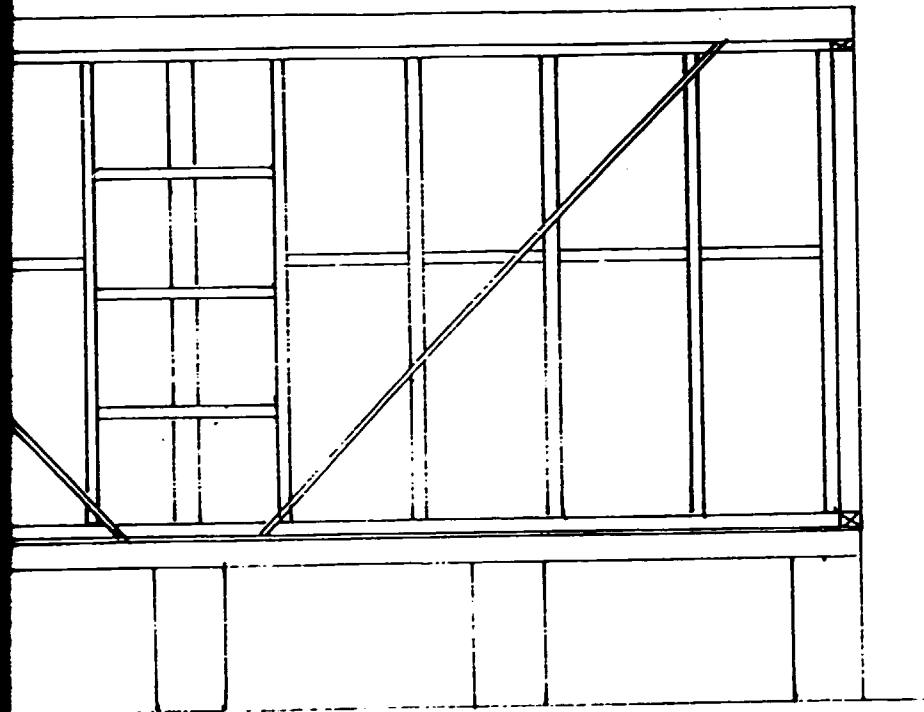

800

2450

60

SECTION 2

NORTHERN END WALL

SOLAR KILN

Sheet No: 13

SCALE 1:30

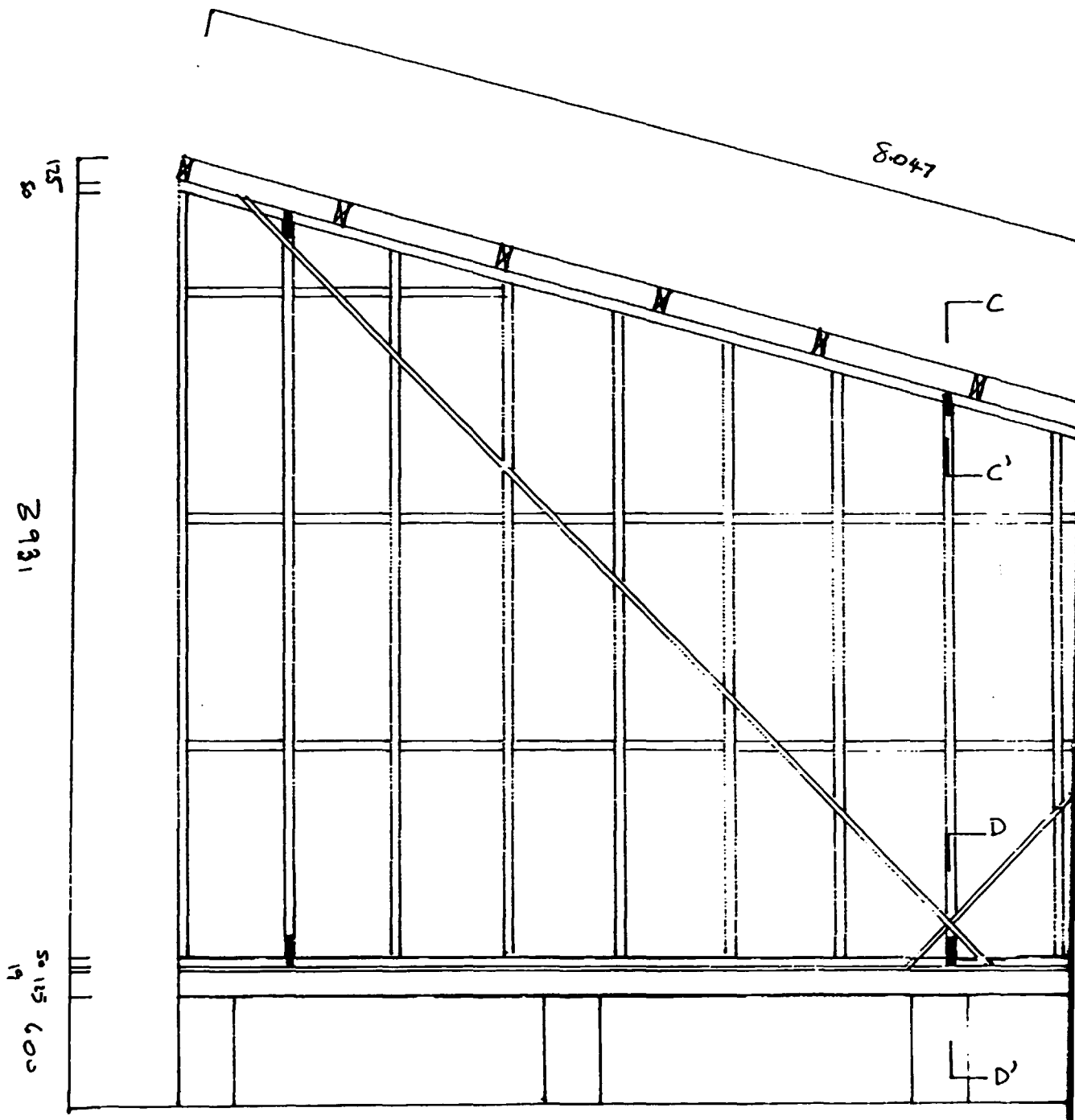

SECTION 1

8-047

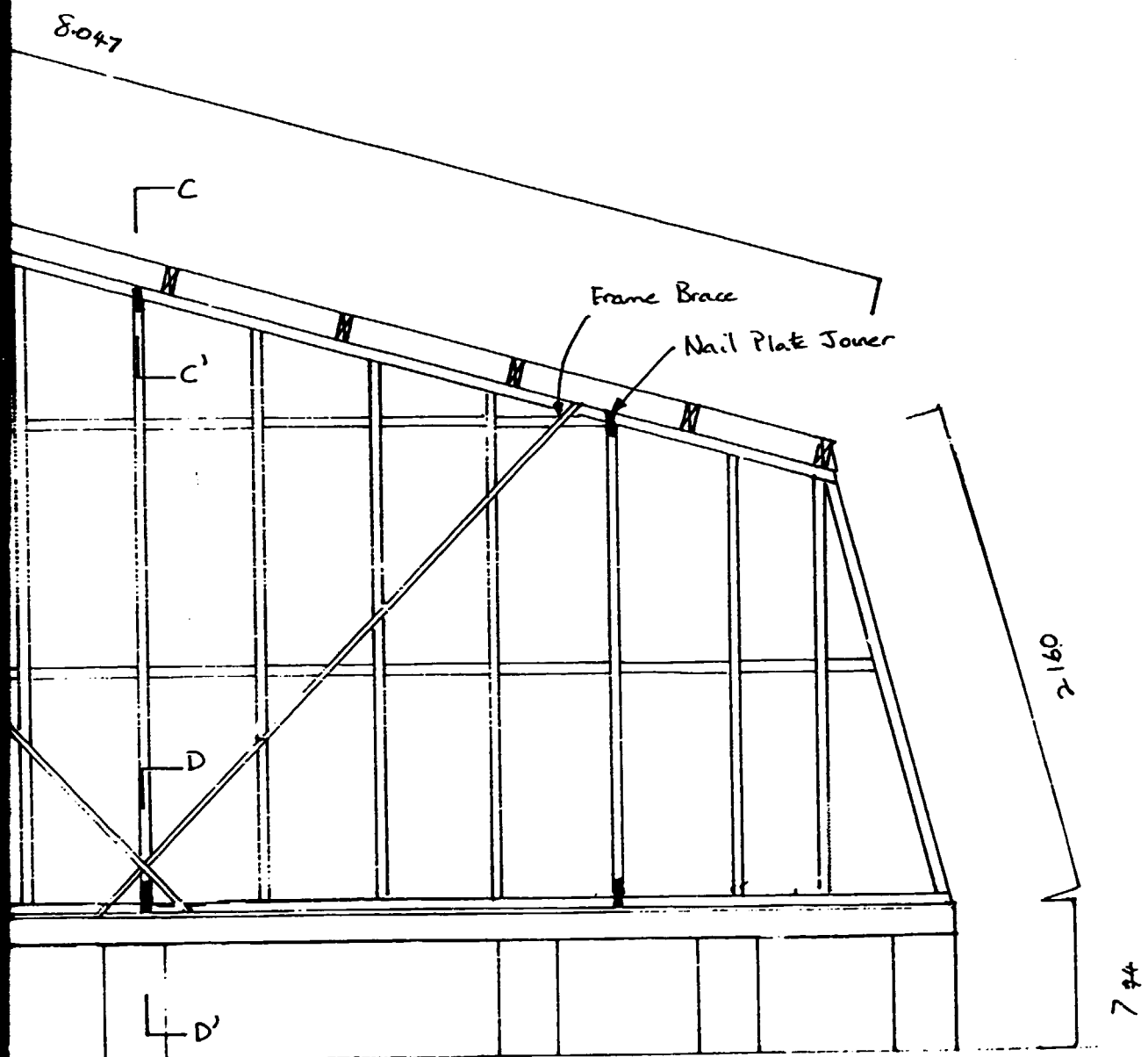

SECTION 2

SIDE WALL FRAME

SOLAR KILN

Sheet No: 14

SCALE 1:30

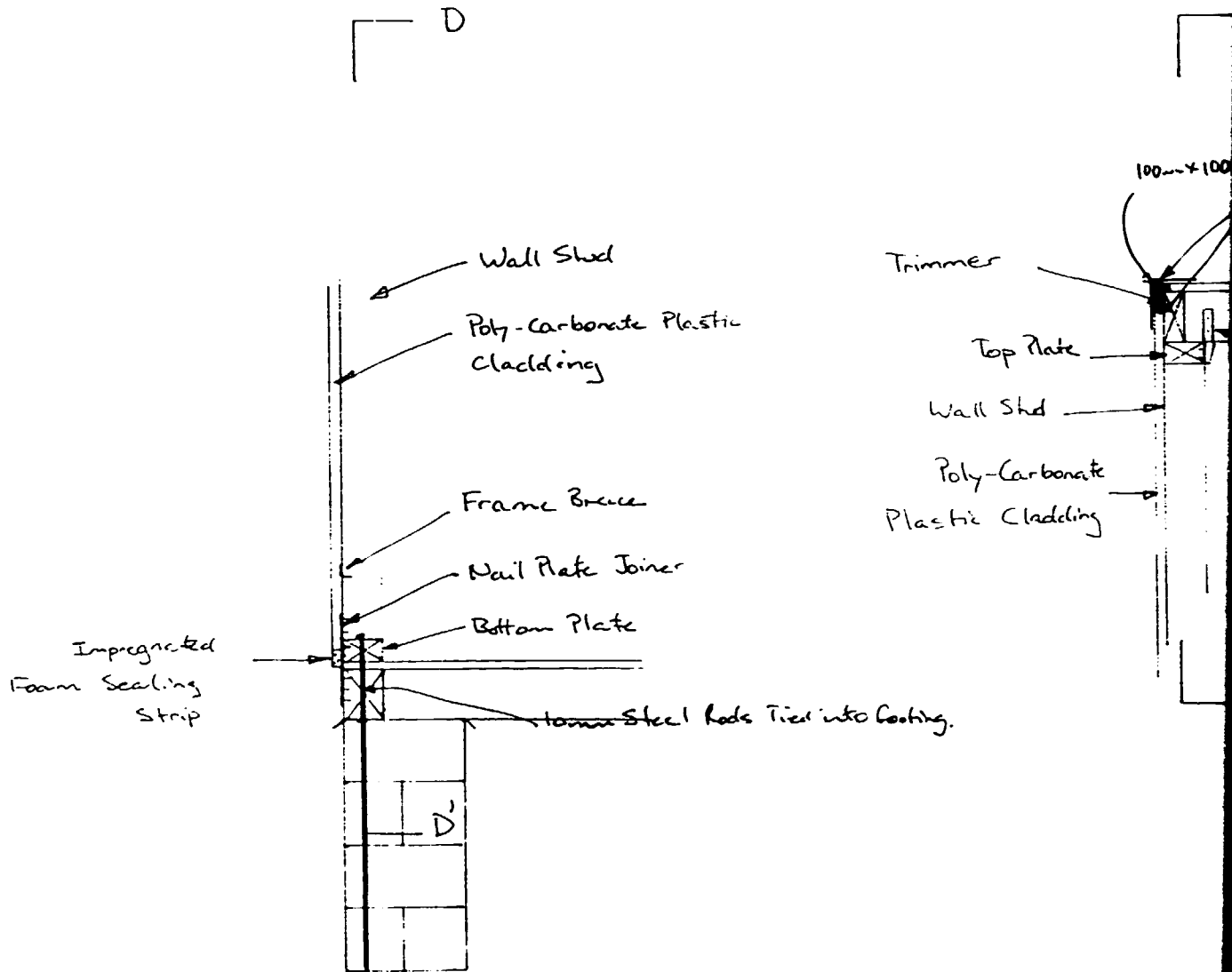

SECTION 1

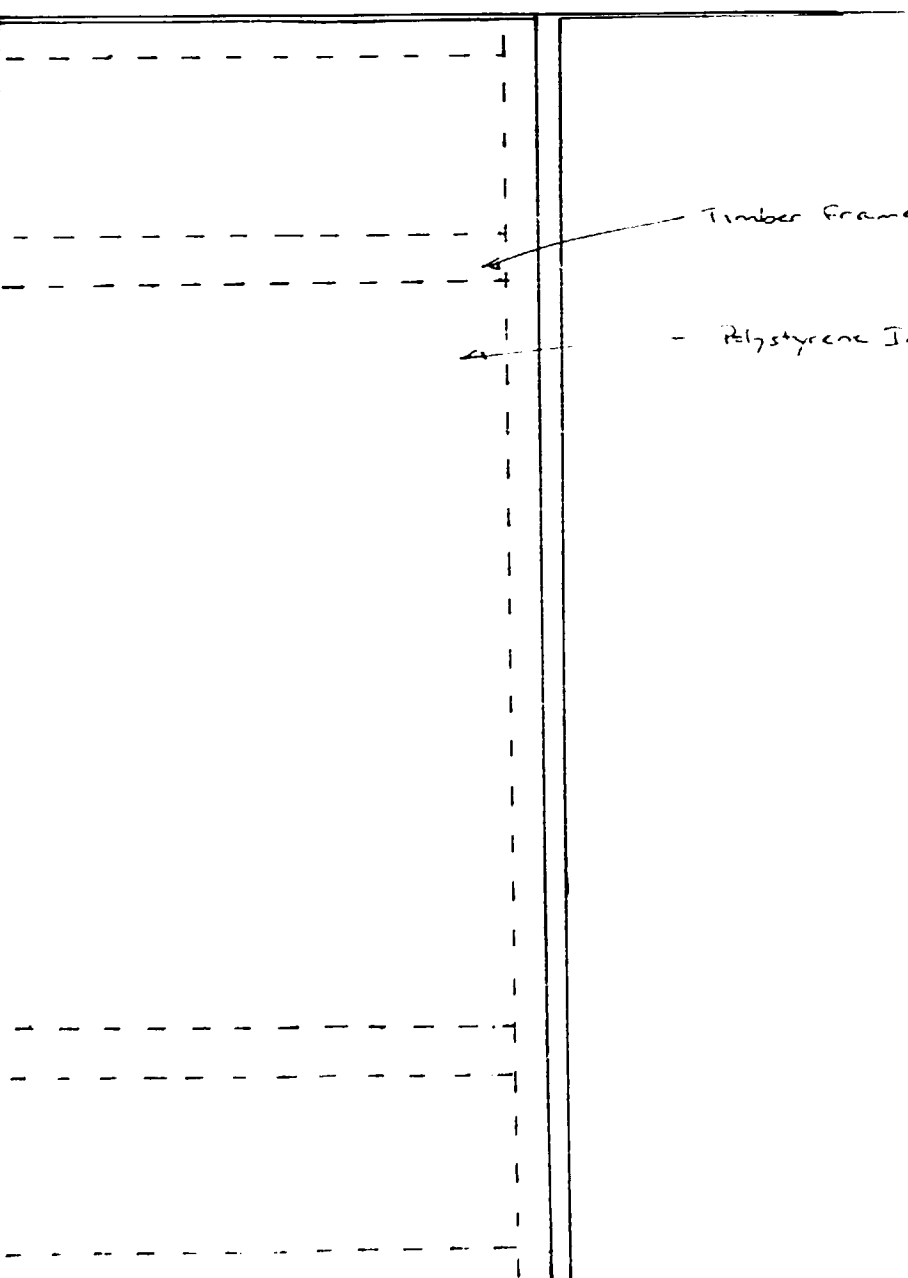
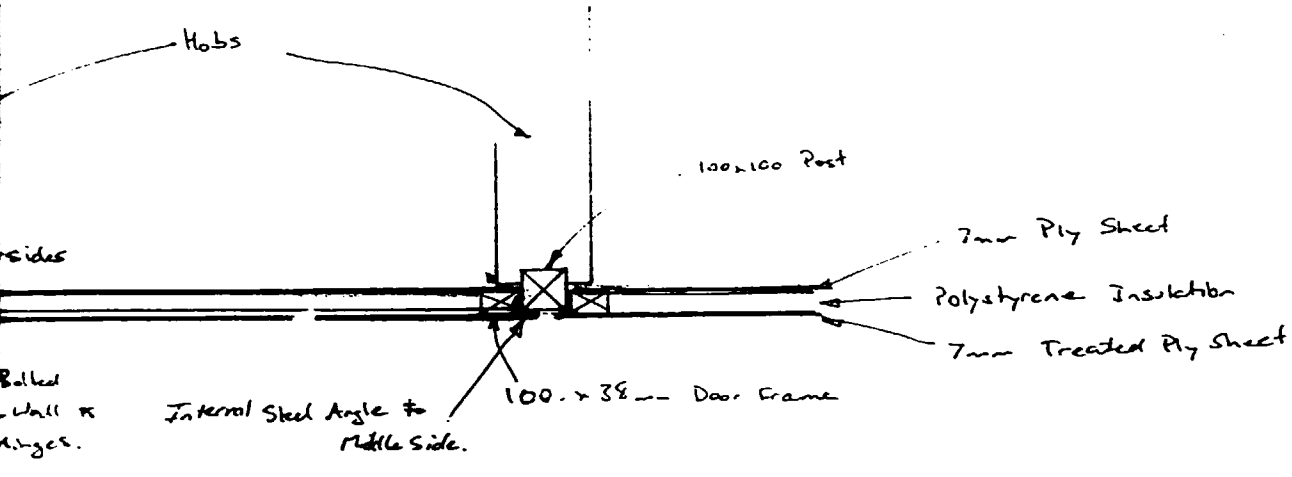

SECTION 2

DETAIL # 6 DOOR SPECIFICATION

Solar Kien

Sheet Nos 16

Scale 1:15

PARTS LIST FOR THE SOLAR KILN

ITEM #	DESCRIPTION	QUANTITY AND UNIT
1	F8TM trench mesh	6 lgths @6 m x 200 mm wide x 8 mm bars
2	Stirrups	18 frames @ 200 mm x 150 mm x 8 mm bars
3	15 Mpa concrete	2 cubic metres
4	Gravel blinding	2 cubic metres
5	Plastic sheet	24 square metres
6	F7Z fabric	2 sheets
7	20 Mpa concrete	3 cubic metres
8	Solid concrete blocks	250 blocks 290 x 190 x 90
9	Solid concrete blocks	31 x 90 x 90
10	Erease blocks	350 blocks 390 x 190 x 90
11	Mortar	
12	Bearers	40 m x 125 mm x 100 mm
13	Bearers	90 m x 125 mm x 50 mm
14	Posts	8 m x 100 mm x 100 mm
15	Block wall bearer	26 x 75 mm x 50 mm
16	Wall framing	2-0 m x 100 mm x 50 mm
17	Roof framing	12- m x 125 mm x 50 mm
18	Door framing	40 m x 100 mm x 50 mm
Note: All timber is to be F" unseasoned or better:		
19	Structural plywood DE 1&2	30 sq. m x 19 mm thick
20	Structural plywood DE	40 sq. m. x 7 mm thick
21	Structural plywood DD treated	30 sq. m. x 7 mm thick
22	Polycarbonate sheet "Suntuff corrugated 860 mm wide"	8 sheets 2.4 m
23	Polycarbonate sheet "Suntuff corrugated 860 mm wide"	24 sheets 3.0 m
24	Polycarbonate sheet "Suntuff corrugated 860 mm wide"	24 sheets 3.6 m
25	Impregnated foam sealing strips	80 x 760 mm
26	Metal angle speed bracing	26 m
27	Flat metal bracing	20 m
28	Clouts	5 kgs x 40 mm x 2.5 mm
29	Bullet heads	25 kgs x 100 mm x 3.75 mm
30	Spiral shank framing nails	1 kg x 50 mm x 3.0 mm 50 mm
31	Triple grips	40 right hand 40 left hand
32	Joist hangers	26

ITEM #	DESCRIPTION	QUANTITY AND UNIT
33	Frame joining plates	30
34	Bolts - block wall	20 x 225 mm x 10 mm
35	Bolts - centre beam	6 x 165 mm x 10 mm
36	Coach screws	12 x 60 mm x 6 mm
37	Roofing screws and gromets	600
38	Paint	Primer and matt black top coat
39	Ant capping	18 square caps
40	Ant capping	18 m strip capping
41	Tie down rods	15 rods
42	Nuts	15 nuts to suit thread
43	Post shoes	5 post shoes
44	Tie wire	1 roll
45	Flashing	29 m x 100 mm x 100 mm
46	Gate hinges	2 pair with screws
47	Pad bolts	2 x 150 with screws
48	Butt hinges	2 pair x 100 mm screws
49	Pad bolts	2 x 100 mm with screws
50	Door sealing strip	15 m
51	Door frame metal angle	15 m
52	Styrofoam insulation	30 sq.m. x 38 mm thick
53	Silicone sealant	3 cartridges
54	Corrugated iron	29 sq.m
55	Fan and motor	
56	Trolleys and rails	

APPENDIX 6

DUTIES OF EXPERT FOR SOLAR KILN INSTALLATION AND TRAINING.

1. Supervise the construction of the kilns.
2. Train local staff in the operation of solar kilns in detail and timber drying in general.
3. Conduct a technical evaluation of the kilns at Samoa Forest Products, Savaii, to assess their current condition, to prepare a maintenance schedule and to conduct operator training.
4. Develop moisture meter correction factors for the range of local commercial species.
5. Document the performance of the solar kilns.

APPENDIX 7

COMMENTS OF THE SUBSTANTIVE OFFICER

1. The consultant did a very thorough job. We concur with all his conclusions and recommendations.
2. We concur with the type of solar kiln he proposes, and with the proposal of erecting additional ones as and when needed both by the sawmillers and the furniture industry - the latter will most probably need their timber dried to a lower moisture content.
3. We also concur with his emphasis on the need for the furniture industry to create, as soon as possible, the Association to negotiate the building of the solar kiln facilities and to administer it. This, to our eyes, is a *sine qua non* condition for any future technical assistance in this field.
4. Since we are not familiar with local conditions, we cannot pass judgement on the relative merits of the site of the Forestry Division and that of the Small Business Centre. However, to our eyes, everything else being equal - or nearly equal - the availability of the Forestry staff to supervise the drying operations (and remedy errors) weighs, initially at least, in favour of the Forestry Department site.