



**TOGETHER**  
*for a sustainable future*

## OCCASION

This publication has been made available to the public on the occasion of the 50<sup>th</sup> anniversary of the United Nations Industrial Development Organisation.



**TOGETHER**  
*for a sustainable future*

## DISCLAIMER

This document has been produced without formal United Nations editing. The designations employed and the presentation of the material in this document do not imply the expression of any opinion whatsoever on the part of the Secretariat of the United Nations Industrial Development Organization (UNIDO) concerning the legal status of any country, territory, city or area or of its authorities, or concerning the delimitation of its frontiers or boundaries, or its economic system or degree of development. Designations such as “developed”, “industrialized” and “developing” are intended for statistical convenience and do not necessarily express a judgment about the stage reached by a particular country or area in the development process. Mention of firm names or commercial products does not constitute an endorsement by UNIDO.

## FAIR USE POLICY

Any part of this publication may be quoted and referenced for educational and research purposes without additional permission from UNIDO. However, those who make use of quoting and referencing this publication are requested to follow the Fair Use Policy of giving due credit to UNIDO.

## CONTACT

Please contact [publications@unido.org](mailto:publications@unido.org) for further information concerning UNIDO publications.

For more information about UNIDO, please visit us at [www.unido.org](http://www.unido.org)



22421

9 August 2000

UNITED NATIONS INDUSTRIAL DEVELOPMENT ORGANIZATION

---

REGIONAL PROGRAMME FOR POLLUTION CONTROL  
IN THE TANNING INDUSTRY IN SOUTH-EAST ASIA  
US/RAS/92/120

WHAT IS THE FUTURE OF (CHROME) TANNING ?  
LEATHER MANUFACTURE IN THE NEW MILLENNIUM

MEET IN AFRICA  
Casablanca, Morocco  
28 September, 2000

**Coordinated by:** A.D. Covington

**Contributions by:** J. Buljan, Project Manager  
T. Ramasami, India  
B. Shi, China  
A.D. Covington, UK  
D.G. Bailey, USA  
W. Frendrup, Denmark

---

*This report has not been edited.*

*The views presented are those of the author and are not necessarily shared by UNIDO.*

*Reference herein to any specific commercial product, process, or manufacturer does not necessarily constitute or imply its endorsement or recommendation by UNIDO.*

## **Preface**

Within its programme of technical cooperation, UNIDO is very seldom involved in developing new technologies. Instead, it sees as its task to transfer well established, proven technologies and assist in having them adjusted to specific local conditions.

Similarly, with medium and small scale tanning units in developing countries as the main recipients of technical assistance, and while trying to keep abreast of the latest innovations, UNIDO is not normally associated with basic research or discussions at an academic level.

Although there are signals that excessive pressures on the tanning industry, concerning the use of chromium salts, have been weakening recently, the issue is likely to continue attracting the special attention of environmental authorities and the general public.

For this reason, in addition to promoting and introducing various good chrome management systems (improved conventional tanning, direct recycling, chrome recovery, high uptake), including safe disposal of chrome containing waste, we felt that it might be worth hearing the competent, even possibly somewhat futuristic and speculative answer(s) to the question:

**"What is the future of (chrome) tanning ?"**

**"Leather Manufacture in the New Millennium"**

**Jakov Buljan  
UNIDO Secretariat,  
Vienna, Austria.  
August 1999**

## **Foreword**

This Workshop came about through discussions between Jakov Buljan and me, concerning new ideas in tanning theory, recently developed within my research group in University College Northampton. Talk centred around the question as to where the future of leather tanning lies, if it is the case that high hydrothermal stability is not confined to chrome and semi metal tanning. This means that organic chemistry is a viable approach to tanning leather. However, there is a big difference between demonstrating the principles of high stability organic tanning and its application on a commercial scale, to produce commercially acceptable leather.

The purpose of this Workshop is to explore the various aspects of current chrome tanning, to attempt to predict the way tanning might change in the coming new millennium, at least during the first half of the new century. Those aspects are:

- Future requirements of leather.
- The future of chrome management.
- Future tanning chemistries.
- Future tanning process technologies.
- The environmental impact of future tanning processes.

To address these topics, we assembled a team of the foremost thinkers in the fields of leather science and technology, from around the world, in order to have a world view of the subjects. Each Expert constructed a Position Paper, which was distributed to all the other members of the team, who provided feedback comments to the authors, who in turn reconsidered their positions and then constructed final Subject Papers, which constitute this document.

This document, the product of long, hard and deep thinking, is offered as a best guess as to how the future of our industry is likely to change. We hope the industry finds it useful and salutary.

**A. D. Covington  
University College  
Northampton, UK  
August 1999**

<b>Contents</b>	<b>Page</b>
Future requirements of leather: a forecast. By Dr. T. Ramasami	5
Future of chrome management By Prof. B. Shi	24
Future tanning chemistries By Prof. A. D. Covington	31
The processing of rawstock in the tannery of the future By Dr. D. G. Bailey	77
Environmental aspects of future tanning methods By Mr. W. Frendrup	96

# Future requirements of leather: a forecast.

**T Ramasami**  
**Central Leather Research Institute**  
**Adyar,**  
**Chennai (Madras) 600 020,**  
**India**

<b>Contents</b>	<b>Page</b>
1.0. Introduction	7
1.1. Future of leather as a unique material	7
1.2. Challenges to leather from synthetics	7
1.3. Challenges to nations with natural abundance of raw materials	7
1.4. Factors driving the future of global leather sector	7
1.4.1. Market forces	7
1.4.2. Technological changes	8
1.4.3. Social pressures	8
1.4.4. Environmental and economic issues	8
1.4.5. Macro changes impacting leather sector	8
1.4.6. Review of process chemistry and tanning technologies: a demand of the hour	9
2.0. Chemistry of tanning: a revisit and forecast	9
2.1. Call for balancing skill and knowledge in science of tanning	9
2.2. Historical perspectives	9
2.3. Chrome tanning: origin of speciality	9
2.4. Rationale in process chemistry of chrome tanning	9
2.5. Post tanning processes for chrome tanned leather: ease of operations	10
2.6. Chemistry of chrome tanning	10
2.7. Molecular basis to chrome tanning: an emerging theme	10
2.8. Improving chrome tanning practices based on scientific approaches	10
2.9. Is total replacement of a tanning system feasible?	11
2.10. Knowledge gaps in developing total alternatives the chromium in tanning	11
2.11. Motivating factors favouring search for alternatives to chromium as a tanning material	12
2.12. Search for inorganic alternatives to chromium as tanning systems	12
2.13. Search for organic alternatives to chromium as a tanning system	12
2.14. Are there non chemical routes to tanning?	13
2.15. Likely trends in beamhouse operations and consequences on tanning operations	13
3.0. Likely changes in process equipment	15
3.1. Some likely directions	15
3.2. Likely innovations in equipment leading to changes in leather processing	16
3.3. New developments to meet new demands	16

3.4.	Some likely directions of equipment modernisation	16
4.0.	Better management of chromium	17
4.1.	Future of chrome tanning: a professional view	17
4.2.	Likely improvements in management of chromium in tanneries	17
4.3.	Likely product innovations to save chrome tanning	17
4.4.	Comprehensive approach to chrome management	17
5.0.	Economic implications of changes in chrome tanning vis-à-vis comparison to process alternatives	18
5.1.	Need to ensure environmental sustainability of processes	18
5.2.	Challenge leading the opportunity in tanning sector	18
6.0.	Tanning technologies: their impact on leather product sector and vice versa	19
6.1.	Challenge on leather for uniformity of product	19
6.2.	Challenge on leather sector for quicker response to market demands	19
6.3.	Product sector in the driving seat	19
6.4.	Changing applications of leather	20
6.5.	Sustainability of technological changes to be decided by market forces	20
7.0.	Concluding remarks	20
	Acknowledgement	21
	References	21

## 1.0 Introduction

**1.1 Future of leather as a unique material:** Leather has remained a unique material for a long time. Visco-elasticity and pore size distributions are two important properties of leather that have rendered it a unique material. The abilities to breathe and readjust to volume fluctuations of the foot have made leather a material of choice in the footwear industry. These properties have not yet been matched. Modern day footwear is nevertheless not dependent on leather. This is in part due to weak coupling between demand and supply of leather.

Whereas the demand for footwear is increasing many fold, global supply of leather has remained more or less constant over several years. It implies that alternatives to leather have met partially the material demand of global footwear industry, although there are no functional synthetic equivalents to leather. A question arises as to the future of leather as a unique material. Will leather become redundant in conventional applications? It seems now that leather may be replaced in several applications [1].

**1.2 Challenges to leather from synthetics:** It is generally believed that in the next millennium, many new materials would be developed and introduced. Synthetic fabrics have not yet fully matched leather in all properties. Wherever functional matching has been possible, leather has already been replaced by synthetic alternatives. A notable example is picking band leathers. Use of leather as a soling material in shoe industry has decreased with the advent of alternative materials. What is the future of leather in the new world of material science and technology? Such questions raise the relevance of natural materials in a challenging environment. It seems highly likely that synthetic equivalents to leather will emerge in the next millennium.

**1.3 Challenges to nations with natural abundance of raw materials:** When the use of copper in transmission of electricity decreased, the importance of nations with natural abundance of the metal decreased as well. It is not unlikely that synthetic alternatives to leather will emerge in the foreseeable future. Nations that enjoy natural abundance of raw materials may not necessarily benefit from the leather industry in the changing global market environment.

**1.4 Factors driving the future of global leather sector:** The likely factors driving the future of the global leather sector need to be discussed prior to discussions on the future of chrome tanning technology. Innovation in both process and product development as well as applications in the polymer industry is one of the important factors driving the future of global leather sector. Competition to leather from synthetics is imminent. When the demand-supply chain is not coupled in the leather sector, competition from synthetics may become even more important than what it would otherwise have been. Factors driving the global leather industry can be considered to arise from market forces, technological changes, social pressures, and environmental and economic issues.

**1.4.1 Market forces:** Currently, in many applications, it is only synthetics that determine the price of leather products and not leather itself. By 2010, the demand for upper materials in the world may increase to 40 billion sq. ft per year at current levels of per capita consumption of footwear [2]. Since the supply of leather in 2010 is not likely to exceed 20 billion sq. ft per year, leather may be able to meet only 25% of the need for upper materials in shoe industry.



The price of shoes will be influenced by the price of materials meeting 75% of the demand. The price of leather used for application as uppers in shoes will be driven by the cost of alternative materials. Similar trends in other applications are also likely. Market competition from synthetic alternatives is one of the most important factors driving the future of leather industry.

**1.4.2 Technological changes:** Leather processing methods have been dominated by traditional practices. Absorption of new technologies in leather sector is slow. Life cycle of technologies in leather processing sector is long. In the current technology regime, development of alternatives to leather is being pursued more vigorously than alternative processes to leather manufacture, to gain cost control and environmental acceptability of processing methods. There appears to be a mismatch in the need for new technologies and its development and applications in leather sector.

**1.4.3 Social pressures:** Leather enjoyed a public perception of being an eco product. In recent times, the environmental constraints of manufacturing methods used in leather processing have challenged the existence of the tanning industry. Social perception of tanning sector is negative, on account of the ecological threat emanating from tanning activity. Pressure groups against tanning activity have emerged in several countries.

**1.4.4 Environmental and economic issues:** The tanning sector in different parts of the world has found it difficult to comply with environmental regulations, when there is strict enforcement of norms. Wherever legal systems are strict about compliance to environmental norms, tanning activity has faced challenges in cost effectivity. Particularly when the price of product is determined by alternatives to leather and supply-demand chain is decoupled, environmental economics in complying with regulatory norms, where enforcement is high, do not seem to favour tanning activity. In the absence of process innovations in tannery sector, environmental economics may disfavour the production of leather.

**1.4.5 Macro changes impacting leather sector:** Water, in the course of time, may become a scarce commodity. The necessity to conserve water will cause changes in many socio-economic activities. Since leather processing is water intensive, almost assuredly, the leather sector will be subjected to serious pressures to conserve water. It is feasible that water consumption in tannery sector may decrease to less than 4 litres of water per kg of leather processed. Zero discharge concepts would force considerable conservation of water in tanning sector.

Land use pattern is another macro economic demand, which may influence the leather sector to conserve space. Land area needed for a tannery is large currently. Waste water treatment plants and solid waste disposal sites add to further demands of land area. With increasing population and demand for food materials, available land for use by the industrial sector is likely to decrease. The return on investments in the industrial sector is likely to be influenced by the costs of land more significantly than presently. It is likely that space saving technologies will dominate the leather sector for gaining economic sustainability.

Land use pattern may also enforce animal stocking policies in developing countries. The farming sector may undergo macro changes, which in turn would influence the leather sector indirectly. Numbers of available hides may decrease due to decreases in animal populations.

**1.4.6 Review of process chemistry and tanning technologies in leather sector: a demand of the hour:** Unless process innovations are made and used, the future of tanning seems challenged. Therefore, a comprehensive and holistic review of the leather sector is in order. The review needs to include a revisit to chemistry of tanning, processing methods as well as emerging better management options for current technologies on the one hand and paradigm shifts towards cleaner technologies and forward and backward integration of tanning sector with up and down stream industries on the other. An attempt has been made to forecast the future of tanning based on an analytical approach.

## **2.0 Chemistry of tanning: a revisit and forecast**

**2.1 Call for balancing skill and knowledge in science of tanning:** To quote from Robert Foerderer in 1899, “ The future of a great leather industry is dependent upon skill and a knowledge of chemical scientific principles. Upon these depend the acceleration and cheapening of the tanning process. Our leather manufacturers must aim to be more than good machinists; they must be practical and thorough chemists” [3]. One hundred years later, the call seems still valid.

**2.2 Historical perspectives:** Tanning as a process has evolved over time. The practice and skill evolved first. Understanding of the underlying chemical principles followed later in the development of the art and science of tanning. The discovery of tanning with plant and organic materials may have been accidental. With increasing demand for aesthetic appeal and softer types of leathers as well as the need for reduction in process time, alternative tanning methods and post tanning operations had to be developed through laboratory experimentation.

The discovery of chrome tanning in 1858 is a landmark in leather processing. Although many alternative mineral tanning materials have been explored, chromium based tanning methods in the manufacture of light and softer types of leathers have stood the test of time. The uniqueness of chromium(III) based tanning materials in leather processing has been much-discussed [4]. The chemistry of chrome tanning has been extensively investigated and reviewed [5-7].

**2.3 Chrome tanning: origin of speciality:** Chrome tanning is easy to practice; but it calls for a deeper understanding, if the activity is to be managed better. Special features of chromium (III) as tanning salt originate from the  $d^3$  electronic configuration as well as the known aqueous chemistry of the metal ion. The stability of the octahedral ligand field geometry of  $d^3$  ion, cationic potential of the trivalent chromium, hydrolytic behaviour of aqua complexes of Cr(III), stability constants of hydroxy bridged polymers of the metal ion and charges and sizes of molecular species in chrome tanning salts make the tanning method unique.

**2.4 Rationale in process chemistry of chrome tanning:** It is generally known that carboxyl sites in collagen, the leather making protein [8], bind chromium. Predominantly, side chain carboxyl residues of side chain amino acids, aspartic and glutamic are implicated in the chemistry of chrome tanning. These carboxyl residues exhibit  $pK_a$  values around 3.5-4.0. This implies that at pH values around 2.5, these residues may be protonated and made unavailable for ready complexation with heavy metal ions. Aqua complexes of chromium(III) also exhibit acid base dissociation behaviour around pH values of 3.5-4.0 in aqueous media [9]. The

process sequence of pickling-chrome tanning-basification has evolved over time, but involves selection of conditions based on scientific principles.

**2.5 Post tanning processes for chrome tanned leather: ease of operations:** Basic chromium sulphate (BCS) salts employed for tanning afford a high degree of hydrothermal stability to the resulting leather [10]. Therefore, mechanical as well as post tanning operations on wet blue leathers can in principle be carried out at higher temperature, without the danger of dimensional stability of the matrix. Chrome tanned leather can be effectively dyed to rich shades using simple and acid dyes. Since chrome tanning renders the collagen fibres cationic, the use of anionic fatliquors to lubricate the fibres and render leather soft is easier. Chrome tanning is primarily a molecular event between collagen and chromium (III) salts. Chrome tanned leather lacks substance or solidity. A need for fibre compaction of final leathers has demanded the use and application of retanning methods. The use of syntans to fill up the void spaces in chrome leather is now a common commercial practice. Large numbers of post tanning auxiliaries suited for chrome tanned leathers as substrates have been developed and are in commercial use already [11]. The performance of chemical formulations employed in post tanning operations in leather sector has been optimised for chrome tanned leather as substrate.

**2.6 Chemistry of chrome tanning:** Although the chemical principles involved in chrome tanning have been extensively investigated and are well understood, an insight into the molecular basis of chrome tanning is still under investigation [12]. A general belief is that the metal ion serves to introduce coordinate covalent crosslinks in collagen [13]. Both intra- and inter-molecular crosslinks have been envisaged. As to whether the metal ion blocks the recognition sites of enzyme-substrate binding or it deactivates the enzymes responsible for degradation of collagenous matrices or the conformation of collagen-chrome complex disfavours enzymatic degradation of chrome tanned leather is not yet known. A deeper and molecular level understanding of chrome tanning is emerging currently [12].

**2.7 Molecular basis to chrome tanning: an emerging theme:** It has now been shown that different molecular species present in basic chromium sulphate salts afford to collagen varying degrees of dimensional stability against heat as well as enzymatic degradation by collagenase. A case for chromium induced long range ordering and assembling of collagen molecules has been made based on recent experimental results [12]. Since a penta fibrillar assembly of collagen presents certain molecular features and polar channels of 7-8 Å unit dimensions, a need to revisit the reported concepts in the mechanism of chrome tanning has arisen. That some specific chromium (III) species present in basic chromium sulphate salts may seem to alter the conformation of collagen, as observed from circular dichroism data, is of interest [12].

**2.8 Improving chrome tanning practices based on scientific approaches:** A study involving reaction of dimer, trimer and a tetramer of chromium (III) species with rat tail tendon fibres reveals that the stability afforded by different species of the metal ion varies with the structure of the complex. A speciation based approach is necessary, prior to any fundamental understanding of the chemistry of tanning. True scientific solutions to the problems faced by the tanning industry are feasible only if the science of tanning is better understood. For instance, a relatively lower degree of utilisation of chromium in chrome tanning needs to be understood in terms of a correlation of molecular structure of Cr(III) species with its affinity to collagen under conditions of tanning [14,15]. If such a structure-

affinity correlation existed, it may be possible to devise technologies for directing the synthesis of basic chromium sulphate towards the preferential formation of high affinity species.

Although alternative and easier methods of better management of chromium may be available, a sound and basic understanding of the chemistry of chrome tanning based on a molecular approach may enable paradigm shifts in tanning technologies based on chromium. The current levels of understanding of chrome tanning may support the development of alternatives to currently used chrome salts and application methods. Chrome tanning can be rendered more efficient based on the current understanding of the method.

**2.9 *Is total replacement of a tanning system feasible?*** The stability of chrome tanned leather against wet heat needs to originate from the increase in long range order induced by the tanning molecule as well as changes in heats of hydration of tanned fibres. Whereas hydrothermal stability of a collagen fibre may be more easily influenced, molecular events involved in tanning with a particular salt or material are not easily reproduced with an alternative tanning system. In other words, through a combination of organic and mineral tanning it may be possible to match the shrinkage temperature of a chrome-tanned leather as in the case of aluminium-mimosa method [16]. However, it may not be possible to match the chemical character of the chrome tanned collagen fibre with respect to charge and molecular stability using alternative methods of tanning.

Matching the functional properties of a tanning system with another is feasible and has been achieved in many previous examples [17]. Nevertheless, replacing chromium by another tanning system without changes in the molecular compositions and mechanisms does not seem possible.

**2.10 *Knowledge gaps in developing total alternatives to chromium in tanning:*** Tanning is more easily described than defined. It has been possible to compare the performance of leathers produced by different methods of tanning and develop practical guidelines for tanning. Each type of tanning method seems to involve different sites in collagen. It is hardly feasible to reproduce all the features of chrome tanning with another material. The emerging insight into the molecular basis and definitions of chrome tanning reveals that different forces may be involved in a stabilisation of collagen against wet heat and enzymes [12]. An assembly of interactive forces may seem to participate in the stabilisation of collagen during tanning. Changes in secondary, tertiary and quaternary structures of collagen during tanning seem likely. Site specificities in the reactions of the tanning species with collagen sites are not well understood. For instance, a given chromium(III) complex may bind to different side chain carboxyl site of collagen but with varying influence on the structure of the collagen assembly as well as stability against heat and degradation by enzymes. The mechanism of chrome tanning has not yet been understood to the required level of resolution for basing the development of alternatives to chromium as a tanning salt on sound and scientific rationales. On the basis of current knowledge, only functional alternatives to chromium (III) salts as tanning systems seem feasible. The development of a chemical alternative to chromium as a tanning system would call for deeper understanding of several and complex issues.

The molecular basis to tanning needs to address various events occurring in Å unit dimensions. Long range ordering induced by the metal ion in molecular assemblies of collagen as well as the changes in surface charges are likely to influence macro properties of the resulting leather

significantly. Especially the interactions of chrome tanned leather with post tanning chemicals are likely to be strongly influenced by surface charges and energies. A suitable theory of tanning needs to explain various observations made at molecular as well as macro dimensions. Alterations in the various hierarchical levels of ordering of collagen and connective tissue fibres need to be explained by a suitable theory of tanning.

Most theories of tanning do not address the changes in structures at varying levels ranging from Å unit to micron level dimensions. Different theories have been proposed for vegetable and mineral tanning systems [18,19]. Organic and inorganic systems seem to implicate different types of interactions to afford stability to collagen. Depending on the types of interactions involved, the stability of the resulting leather also seems to vary with the nature of the tanning system.

Some attempts have been made to develop a unified theory and explain the mechanism of tanning with widely differing materials based on some elementary steps; as for instance changes in hydration behaviour [20]. It is not clear whether a unified theory is feasible and realistic and if so, would such a theory enable the development of alternatives to chromium as a tanning system? It seems that such a development is highly unlikely. In the event a unified theory for tanning is difficult, development of alternative tanning systems to chromium based methods needs to be based on factors other than process chemistry.

**2.11 Motivating factors favouring search for alternatives to chromium as a tanning material:** There has been an ongoing search for alternatives to chromium as a tanning material [21]. The primary motivation for such a search has been due to environmental concerns associated with the discharge of unused chromium and the potential problems in the safe disposal of solid wastes containing the metal ion. Life cycle analysis of chrome tanned leather has not yet been carried out scientifically, but there is sufficient ground to raise questions against the disposal of used chrome tanned leathers through incineration. Since chromium is not a renewable resource, alternative systems are necessary for industrial applications; especially if the metal ion plays a critical role in tanning industry.

**2.12 Search for inorganic alternatives to chromium as tanning systems:** The use of alternative mineral tanning salts based on aluminium, titanium, zirconium, iron, silica has been proposed and attempted with varying degrees of success [22]. Total replacement of chromium by other mineral tanning salts has been attempted without much commercial impact. Any serious changes in tanning would call for significant alterations in both beamhouse and post tanning operations. A phenomenological approach has been adopted to locate alternatives to chromium as a tanning material. Inadequate attention has been paid to matching the chemical features of Cr(III) which render BCS as a mineral tanning salt.

**2.13 Search for organic alternatives to chromium as a tanning system:** Reports have been made that it is possible to match the dyeability as well as softness of chrome based leathers using organic tanning systems in place of chromium(III) [23]. Such methods have involved alterations in post tanning operations. Functional properties of final leathers in terms of softness, richness of dyeing and fullness of leathers have been matched. A serious and viable alternative system should ensure also cost effectivity and greater environmental security compared to chrome tanning. Most of the alternatives based on organic systems have been associated with higher input costs per unit area. In spite of the significant amount of work in

this direction, commercial scale adoption of alternative methods has been limited. There have been claims of eco tanning [24]. These claims are based on a perception that vegetable tanning materials are biodegradable. Although the biodigestion of vegetable tannins is feasible, the influence of biocides on the biodegradation of such tanning materials is not well defined. Eco-criteria for the selection of a tanning system should be based on life cycle analysis as well as the eco-benign nature of all necessary chemical inputs.

**2.14 Are there non-chemical routes to tanning?** Conventional wisdom of tanning technology has mostly employed chemical approaches to long term preservation. If the long term preservation of collagen demands only changes in selected sites and changes in conformation of the protein, in principle, it should be possible to make and break bonds to order within a collagenous assembly and stabilise using only electromagnetic radiation. Earlier attempts with gamma-radiation have not led to much success [25]. With the advent of modern laser technologies, it is not impossible to reorder collagen using irradiation methods. These techniques are not likely to impart the required bulk properties to leather and match the charge characteristics of chrome tanned stock. This would mean redesigning the pre- as well as post-tanning operations. All these are not without cost implications.

**2.15 Likely trends in beamhouse operations and consequences on tanning processes:** It is now recognised that beamhouse operations employed in commercial processes in tanneries need to be audited for their environmental consequences and altered [26]. The negative image suffered by the tanning industry among the public would necessarily force technological changes in the beamhouse operations in tanneries. Alternatives to salt based curing, sulphide and lime based dehairing, ammonium salts in deliming and salt rich pickle methods may emerge. Since the main objective of beamhouse operations is to remove unwanted interfibrillary matter and prepare the stock for tanning, brute force methods based on usage of large amounts of chemicals will have to necessarily yield to other more selective methods. These changes are indicated not only because of environmental considerations, but also due to economic criteria.

The leather industry has remained foot loose during the last fifty years. Drifting and shifting of manufacturing activities to different parts of the world have been general trends during the last twenty years. Manufacturing activities have been shifting to countries with lower wage levels as well as less intense regulatory mechanisms for environmental laws. Developing countries with command over raw material supply have been employing protectionist policies to safeguard the flight of raw hides and skins from their nations. In the World Trade Organisation regime, trade on raw hides and skins may become more global. Technology changes are therefore likely in the leather processing sector.

**Curing:** Curing methods employed for short-term preservation may undergo changes when the leather industry is further globalised. Salt based curing methods would necessarily undergo a change because of the environmental as well as transport related issues. Ambient preservation of raw hides and skins, processing of green hides and skins, return to flint drying and preservation based on biocides seem the likely trend. Technologies based on radiation, controlled drying and other physical rather than chemical methods may become popular.

**Fibre opening and recovery of high value byproducts:** Currently used methods for fibre opening employ primarily osmotic swelling approaches [26]. Osmotic swelling does cause

loss of area. Although osmotic swelling is considered reversible and it is generally believed that area lost during liming is regained in subsequent operations, future approaches may involve the use of bioproducts and lyotropic swelling for fibre opening. Especially when leather is sold on the basis of area, beamhouse methods that ensure fibre opening without loss in area and better still provide an opportunity for gaining in area may become popular. One of the water consuming operations in leather processing is soaking. Soaking is likely to undergo important changes.

Fibre opening at the stage of raw hides and skins may involve the use of novel surface active agents and bioproducts that are capable of selective removal of non-collagenous matrix components. Sulphide may be partially if not totally replaced in leather processing operations. For the removal of hair, an approach to dissolve rather than degrade the cementing substance may be the preferred direction. For dissolution, technologies like supercritical fluid extraction may be explored. In the event non-aqueous systems are employed for dissolution, float recycling will become an integral component of leather processing.

Recovery of value from non-collagenous matrix components will become necessary if leather were to compete favourably in cost with other matrices. Cost effective and clean recovery of proteoglycans and glyco- and lipo-proteins, amino acids from fleshings and hair as well as other proteins are likely to gain significance. Raw hide and skin needs to emerge as a source of multiple products apart from leather.

**Deliming:** It is not impossible that the operation of deliming will be slowly replaced. Since the use of lime in leather processing is likely to be discontinued, deliming may become redundant. A process operation in which pH adjustments are made without the use of conventional delimiting agents based on ammonium salts would become more relevant.

**Bating:** More efficient processes in bating, through the use of more effective enzymes and recovery of products, seems the likely direction. Bating in the future may be carried out in non-aqueous media.

**Pickling:** With increasing recognition that sulphate ions form one of the most serious sources of constraints in tannery waste waters, pickling is likely to undergo significant changes. Pickle free processing is a future direction. The necessary preparation of stock for tanning through pH adjustments may be achieved without the use of salt and large amounts of sulphuric acid.

**Tanning:** The use of chromium in tanning is likely to face further threat. More efficient processes of tanning with near zero waste concepts will be introduced; but the most significant challenge for the chrome tanning is likely to arise from the need to dispose used leather products without the danger of conversion of chromium(III) into the hexavalent state. Total life cycle analysis of chrome tanned leather may indicate a posed threat. Although it may be tempting to return to vegetable tanning and process innovations to render vegetable tanned leather soft may be achieved, it is not likely that mineral tanning will be replaced. Land use pattern in 2050 AD may not favour the large scale cultivation of vegetable tannins, unless new biotechnologies revolutionalise the management of forest products. Organic tanning based on non vegetable sources may emerge; but it is not clear as to whether more than 50% of leather made in the world would be based on organic tanning.

Among the various transition elements with a potential to replace chromium, iron is the most likely contender. The availability of zirconium will be self-limiting. Although aluminium enjoys the advantage of large abundance in the earth's crust, in the long run, tanning salts based on iron may be preferred. Chromium(III) enjoys a unique position based on its electronic configuration and aqueous chemistry. Near total replacement of chromium seems unlikely by virtue of the versatility of wet blue stock. Technologies for better management of chromium in tanneries and utilisation of chromium bearing solid wastes may emerge to sustain the tanning methodology. Unless the incineration route for the disposal of used shoes is overcome, chromium based tanning method may suffer. Plasma technologies for the disposal of solid wastes may emerge as useful, but recovery of chromium from used footwear and other leather products and its utilisation may hold a clue to the survival of the chrome tanning process. Future development may be focussed on better management of chromium, based on a cradle to grave approach in tanning industry.

All the developments in chrome tanning would be sustainable only if technological upgrading in ore dressing is parallel to the advancements in down stream applications of chromium. Unless a safe and secure solution to the problem of disposal of solid wastes in chromium based industries as a whole is developed, chromium based tanning methods cannot be sustained. The most serious challenge to chrome tanning is likely to arise from the environmental unacceptability of currently used methods in leaching of chromium from the ore.

In the absence of developments towards greening of chromium based industries, iron appears to be potential alternative to chromium in tanning sector. Although tanning materials based on aldehyde and other organic compounds may find applications in some special processes, for bulk applications, mineral and vegetable tanning materials may well continue to be dominant.

**Post tanning:** Any change in tanning method would influence directly post tanning operations. New classes of retanning agents, fatliquors and dyes would be introduced to match the changes in other operations in tanneries. The future direction in the development of fatliquors is likely to involve higher lubricity per unit weight of fatliquor. Dyeing as a process is likely to undergo large changes. Drum dyeing may be replaced by other methods of applications.

**Finishing:** It is not impossible that finishing may be shifted away from tanneries. Finishing may be carried out on components and leather products rather than on leather. This would mean that the finishing chemicals would undergo major product innovations. Powder coating technologies in leather finishing are likely.

### **3.0 Likely changes in process equipment**

**3.1 Some likely directions:** Process equipment used in the tannery sector has included vessels and devices for agitation and mixing, reduction of sizes and thickness, drying, and surface coating and finishing. Conventional stirred tank reactors like drums are useful when the float employed can be discharged and is not recovered. When increasing use of zero discharge technologies is made, presently used drums may need to be replaced. In the course of time, the shaving operation may become redundant for economic reasons. Better splitting machines may enable achieving uniformity and closer tolerances in thickness. Drying being the most energy consuming operation in tanneries, better designed dryers and use of non-conventional energies for drying may become more relevant. Surface coating equipment may



concentrate on total utilisation of finishing materials. Powder coating appears to be a future direction. Roller based equipment may replace plating machines due to the ease of process automation.

The level of process automation is bound to increase and materials handling systems would undergo major changes? Leather processing will become progressively less labour oriented. Process rationalisation may demand that equipment performs more than one function. Multiple operations may be performed with most devices. Surface finishing equipment is likely to call for large innovations in machine design and development.

### ***3.2 Likely innovations in equipment leading to changes in leather processing:***

Innovations in fleshing machine may obviate the need to swell using osmotic forces. In current industrial practice, flesh is swollen with copious amounts of water. A paradigm shift in methods of removal of flesh may involve the dewatering of flesh prior to its removal. Special dewatering methods may be developed for fleshings. The removal of flesh from hide or skin therefore may be achieved by use of alternative devices than the currently used fleshing machine, which is designed for shear forces against a swollen mass of fleshings. An approach to increase brittleness of fleshings through special drying mechanisms may emerge. Splitting machines for skins, and dry splitting devices are likely directions. High pressure penetrators may speed up the diffusion of materials and assist in process rationalisation.

Liquid-liquid extraction may find increasing applications in the leather sector. Devices for float recycling and use of new technologies like super critical fluid extraction for recovering high value biochemicals from hide and skins may attract interest.

***3.3 New developments to meet new demands:*** It is now known that currently employed technologies in leather processing lead to a wastage or low value applications of nearly 50% of the protein matter in hides and skins. Due to both environmental and economic reasons, technologies for the near total use of protein matter will emerge. New polymer-collagen and polymer-leather composites may be developed. These would demand a new range of equipment.

Occupational health and safety criteria in the tanning sector would enforce changes in equipment design and fabrication for increased worker safety. Noise levels in tannery equipment would need to be reduced considerably. Materials of construction of equipment in the tanning sector would need a change. It is likely that wooden drums may be replaced in tanneries. Use of robots and devices for process automation and control would be more extensively made.

***3.4 Some likely directions of equipment modernisation:*** Process control systems in leather thus far have faced challenges because of the need to correlate measurements made in the floats with those inside the matrix. Indirect investigations have formed the basis of process monitoring devices. Human intervention has so far not been avoided in quality checks in the leather sector. More objective methods of grading and evaluation, based on solid and liquid-imaging devices, may impact the leather sector. Molecular and ion probes may enable direct monitoring of changes inside leather making processes. It is now possible to obtain information on water structures inside matrices at resolutions of micron level dimensions. With the advent of developments in electronics and data processing methods, it is likely that greater

resolution of distances is feasible. Measurements of pH, temperature, viscosity, density, pressure and volume inside leather matrices using non-invasive and continuous monitoring devices are likely. Grading of leathers using ultra sound scanners and non-destructive and objective testing may bring about marked changes in the leather sector. Tanneries in 2020 AD and beyond may become more capital and equipment and machinery intensive. Equipment infrastructure in tanneries would enable the near or total utilisation of chromium in leather processing, through recourse to both process and equipment innovations.

#### **4.0 Better management of chromium**

**4.1 Future of chrome tanning: a professional view:** Although there have been predictions that chromium would be replaced in tanning by other materials, it is our opinion that total replacement of chromium in tanning may not be required or realistic within the next twenty years. Better management of chromium will be the immediate direction of choice in tanneries.

**4.2 Likely improvements in management of chromium in tanneries:** Chromium recovery and reuse may be extensively followed in the near future. Various modifications to the methodology of chrome recovery processes may be introduced. In the long run, however, cleaner tanning methods may replace a separate chrome recovery step. Through the use of high exhaust chrome tanning practices, direct recycling of spent tanning solutions would become feasible. It is our view that near total utilisation of chromium would be a reality in commercial practice in tanneries.

Product innovations in the chrome tanning salt would enable increase in absorption levels of chromium to more than 90% of the metal ion. New delivery systems for chrome tanning salt inside the protein matrix may emerge. The composition of chrome bearing sludge in tannery wastewater treatment plants may change. Utilisation of such a sludge would become feasible. Chemical and bio-leaching of chromium from solid wastes would be technically attainable.

**4.3 Likely product innovations to save chrome tanning:** Use of new chrome savers, chrome exhaust aids, high exhaust chrome tanning salts and mixed metal tanning systems are likely directions in the better management of chromium. It is now recognised that chromium species contained in BCS enjoy several special features, which render them unique in tanning. A polar charged cavity of about 8Å within the penta fibrillar framework of collagen has been recognised. Dimeric complexes of Cr (III) with dihydroxo structure afford higher hydrothermal stability than other species contained in BCS [12]. This in part has been explained as due to the molecular size of the dimers matching the dimensions needed for crosslinking tropocollagen molecules in the penta fibril assembly. Both the nature and extent of intermolecular interactions feasible with Cr(III) seem unmatched so far by other transition elements. On the basis of structure-activity relations, it is now possible to design BCS salts which would contain mostly species of high affinity [27].

**4.4 Comprehensive approach to chrome management:** Through designed alterations in BCS manufacture, new types of high exhaust tanning salts would become available. Direct recycling of spent tanning solutions from high exhaust tanning method will then be feasible [28]. It is also likely that newer devices would enable rapid penetration of chromium into the skin matrix. Solvents with lower dielectric constants may emerge as chosen reaction media for

chrome tanning. Chrome bearing sludges may be almost totally eliminated in tanneries due to the practice of cleaner tanning technologies. Better management of chromium in tanneries may need to be comprehensive, by the application of technologies for the utilisation of chrome shavings and buffing dust, as well as safe disposal of chrome tanned leather based products. It is believed that for economic reasons, better utilisation of solid wastes would become a standard industrial practice within the next ten years. A holistic solution to the technological problems faced by the leather sector is feasible. Such a solution would involve also the safe recovery of chromium from used leather products. When chrome tanning is challenged, the theory of chrome tanning will be better understood. Newer insights into the special features of chrome tanning may be recognised in the search for process and product alternatives. Technologies for better management of the chrome tanning method may reach industrial practice.

## **5.0 Economic implications of changes in chrome tanning vis-à-vis comparison to process alternatives**

**5.1 *Need to ensure environmental sustainability of processes:*** Environmental consequences of chrome tanning have been extensively investigated [29]. Life cycle analysis of chrome tanning method as practised commercially has been made. The leather processing sector as an industry may undergo major changes due to several reasons during the next fifty years. Changes in beamhouse as well as tanning technologies are bound to occur. Chrome tanning as a method needs to emerge more efficient with respect to process wastages and material loss. Equipment as well as product innovations are certain to impact chrome tanning technologies.

Alternative methods of tanning based on organic materials would undergo simultaneous developments. Organic tanning methods are likely to gain a more eco-friendly image compared to mineral tanning systems. Public perception of eco-friendliness or otherwise of a product and process may influence strongly the technology management systems. Chrome tanning is likely to suffer a negative image compared to alternatives based on organic tanning. It is only through a systematic approach the environmental sustainability of chrome tanning process can be established.

**5.2 *Challenge leading the opportunity in tanning sector:*** Major changes in beamhouse operations may influence organic and chrome tanning methods nearly equally. Life cycle analysis of the changes in beamhouse may not differentiate chrome and organic tanning systems. Marked differences in post tanning inputs for leathers based on chrome and organic tanning technologies cannot be easily avoided. These differences would be attended by both environmental and economic implications. Chrome tanned leather is a better substrate to receive currently used post tanning chemicals. Organic tanning process alternatives may demand chemical inputs for post tanning with higher costs.

A competitive approach for the delivery systems for chrome tanning technologies may involve a detailed analysis of the environmental economics of the mineral tanning method and its process alternatives. Such an analysis would be based on costs of changes required in equipment, materials and safe treatment. Scientific data would be necessary to meet the challenges of the public perception based images. It is believed that a detailed analysis would present chrome tanning as a more economic option to a tanner. Better and total utilisation of

chromium on the one hand and attendant benefits in the reduction of chemical inputs in post tanning chemicals on the other, would favour the continued use of chrome tanning. Benefits in environmental costs would become the driving factor in technological changes. Therefore in our opinion, technological changes may favour chrome tanning and economic implications may be more advantageous. Process alternatives may pose a serious challenge and threat. Such a challenge is likely to present an opportunity for the development of better technologies for chrome tanning. Within the next twenty years an environmentally secure chrome tanning system may be placed on sure ground, after a detailed analysis of the environmental costs of emerging alternatives. It is our considered view that chrome tanning technology may be challenged so hard that new opportunities will emerge.

## **6.0 Tanning technologies: their impact on leather product sector and vice versa**

**6.1 Challenge on leather for uniformity of product:** It is to be expected that major changes in tanning technologies would be introduced in the leather sector. Since leather is an input into the product sector, it is relevant to analyse the impact of such changes on leather product industries. Demands of the product sector may remain the most important driving factor causing changes in the tanning industry,

Alternative materials to leather are bound to multiply in number and improve in performance. Leather may even be replaced in many conventional applications. Leather may also have to undergo changes in processing technologies to meet the quality demands of the product sector. Lower cutting value of leather is one of the most serious limitations pointed out by the product sector. It is therefore likely that leather processing sector would be forced to innovate technologies for increasing the uniformity of the substrate with respect to strength and quality. It is a challenge.

**6.2 Challenge on leather sector for quicker response to market demands:** One of the emerging demands of the product sector is quick response time for the market requirements. Delivery time in the leather product sector is decreasing markedly. These demands may favour the trade between a tanner and product manufacturer on crust and product components rather than finished leather. Finishing may be carried out by the product manufacturer on the product or at the component level. These changes are likely to impact seriously upon the tanning sector.

Changes in leather processing technologies need to present a cost advantage relative to other materials. This may be a difficult task due to the economies of scale of operation in the leather sector. Quality advantages enjoyed by leather sector are being matched by several other materials in some applications. It is our view that the usage pattern of leather may change. Leather would slowly find applications in products of high value such as in automobile industry. The durability of leather may provide a market advantage.

**6.3 Product sector in the driving seat:** Changes in leather processing technology may influence the product sector in terms of cost of leather and eco-acceptability of the manufacturing process. It is our view, however, that the changes in technologies and process chemistry in leather sector would have to necessarily meet the demands of the product industry and may not be able to influence the product sector large enough to cause technological changes in manufacturing of products.

**6.4 *Changing applications of leather:*** The likely trends are that leather would be further replaced in footwear applications. It is not unlikely that only about 50% of the footwear made in the world would contain leather and only 25% of the upper materials used in footwear industry would be based on leather. Versatility of leather to accommodate changes in the material composition of footwear and demands of footwear may be the main development in the sector. Applications of leather in garment industry may decrease further. Sectors where leather may find new avenues are in high price segments of consumer product chain and special applications in industrial sector like automobile upholstery.

**6.5 *Sustainability of technological changes to be decided by market forces:*** Leather needs to perform the functions required in the product sector and in a competitive material world the product sector may not readjust to the performance characteristics of leather. The changes in process technologies in the tannery sector would have to enable leather to meet the property demands of the product sector. Perhaps, only those changes in technologies which enable leather in this requirement may be economically sustainable.

## **7.0 Concluding remarks**

There are many basic questions in the perceived future of the tanning industry as well as chrome tanning. Alarmists predict doom for the chrome tanning practice. It is true that the public perception of chrome tanning is negative [30]. A soft option is to replace the process regardless of merit. A process evolved over nearly 150 years may have limitations, but the strength of chrome tanning remains unmatched to date. It is a benchmark for other tanning methods. Understanding the underlying principles in chrome tanning has vastly improved. It is now possible to design processes and technology management practices, which are devoid of limitations. In summary, it is our considered view that the total replacement of chromium in tanning may take longer than 20 years, if not, 50 years.

The fear of replacement will drive the technological innovations. Better management of chromium will become an industrial practice before long. Major changes in the leather sector in our view would be caused by competition from other lower priced synthetic materials in conventional applications. Leather is no longer in the world of limited range of materials. Newer materials will pose a serious threat to traditional products like leather. This challenge is harder to overcome than those from environmental issues. Technologies could help to overcome problems relating to environmental issues, but several factors are required for combating the challenges from new materials.

The durability and aesthetics of leather are two important selling points. Aggressive marketing of leather in new applications would become necessary. At present, the leather sector is market driven. Probably, in 2020 AD the leather sector may become technology driven. Technological innovations may then drive new applications of leather. The marvel of the architecture of skin would enable the leather sector to present innovative leather products in a competitive world.

There are several pessimists in the leather sector. A pessimist is one who sits in front of a chocolate cake and worries about calories. As an optimist, the author would like to argue that there is an opportunity enforced by the challenge. The opportunity waits to be exploited by the scientific community. Science is too strong to let other priorities drive leather out of the

market and chromium out of tanning in the next fifty years. Problems exist; but so do solutions.

**Acknowledgement:** The author thanks his colleagues for their collaboration and discussions at various times on the subject matter of this paper. He has been able to acknowledge a few through citations to some papers, but it has not been possible to include the names of all his collaborators. The area covered in this work being large, he records his thanks to those several professional colleagues and peers with whom he has held discussions on the subject over two decades.

## REFERENCES

1. "Task force report on Futurology of Leather", Committee on Vision Beyond Mission, Govt. of India, Submitted in 1998.
2. Ramasami T., Bhat K.N., Naidu P.S.R., Rao K.S., Subramanian N. and Moulik T.K. (1994) 'Material resources. In: Indian Leather 2010 – A technology, industry and trade forecast', pp. II. 101-205.
3. Mc Laughlin G.D. and Theis E.R. (1945) Chrome tanning. In: The chemistry of leather manufacture, ACS Monograph Series, Reinhold Publishing Corporation, New York, pp. 415.
4. Chandrasekaran B., Rao J.R., Sreeram K.J., Nair B.U. and Ramasami T., (1999), Chrome tanning: State-of-art on the material composition and characterisation, *J. Sci. Ind. Res.*, **58**, pp.1-10.
5. Covington A.D. (1997) 'Modern tanning chemistry', *Chem. Soc. Rev.* pp.111-126.
6. Santappa M., Ramasami T., and Kedlaya K.J. (1982) Science and technology of chrome tanning, *J. Sci. Ind. Res.*, **41**, 616-627.
7. a) Gustavson K.H. (1956), The chemistry of chromium salts and chrome tanning. In: The chemistry of tanning processes, Academic Press Inc. New York, pp.5-58;  
b) Ramasami T., Chandrababu N.K., Chandrasekaran B., Rao J.R., Kanthimathi M. and Narasimhan V. (1987), Approach towards low waste chrome tanning. In: Trends in mineral tanning and resource potential, (Ramasami T. and Thyagarajan G. eds.) CLRI and COSTED, pp. 167-199;  
c) Wilkinson G. (1987), Comprehensive coordination chemistry, Pergamon, Oxford, **3**, pp. 699-972.
8. Shuttleworth S.G. (1978) The mechanism of chrome tanning. In: The chemistry and technology of leather, (O'Flaherty F.O., Roddy W.T., Lollar R.M eds.), **2** pp 281-322.
9. a) Canon R.D. and Earley J.E. (1965), Aqueous chemistry of chromium(III), *Transition Metal Chem.*, **1**, pp 34-90;

- b) Larkworthy L.F., Nolan K.B. and O'Brien P (1987) Chromium. In: Comprehensive coordination chemistry – The synthesis, reactions, properties and applications of coordination compounds – Main group and early transition elements, (Willkinson G. ed.) **3**, pp 701-969.
10. Heidemann E. (1993) Tanning with metal salts. In: Fundamentals of leather processing, Eduard Roether KG, Darmstadt, pp. 295-340.
  11. Sharpouse J.H. (1989), Finishing. In: Leather technician's handbook, Leather producers association, Northampton, UK.
  12. a) Gayatri R., Rajaram A., Rajaram R., Govindaraju K., Nair B.U., Rao J.R. and T.Ramasami (1997) Chromium induced structural changes in biomolecules, *Proc. Indian Acad. Sci.*, **109**, pp. 307;  
 b) Gayatri R., Rajaram R., Nair B.U., Chandrasekaran F., and Ramasami T., (1999) Chromium-induced molecular assemblies and long range ordering in collagenous tissues: A conceptual insight into chromium tanning, *Proc. Indian Acad. Sci.*, **111**, pp.133-145.
  13. Gustavson K.H. (1952) The effect of esterification of the carboxyl groups of collagen upon its combination with chromium compounds, *J. Am. Chem. Soc.* 4608-4610.
  14. a) Balasubramanian N., Janakiraman M.N., Ramasami T. and Ramaswamy D. (1980), Composition des sels de tannage au chrome et leur affinite pour le collagene, *Rev. Tech. Inds. Cuir.*, **72**, pp. 46-51;  
 b) Slabbert N.P. (1976), Chromium(III) complexes present in basic chromium sulphate, *Das Leder*, **27**, pp. 24-26;  
 c) Takenouchi K. (1997), Reactions of chromium complexes with collagen, *Hikaku Kagaku*, **43**, pp.137-145; d) Rao J.R., Nair B.U., Ramsami T., (1997) Isolation and characterisation of a low affinity chromium(III) complex in chrome tanning solutions, *J. Soc. Leather Technol. Chem.*, **81**, 234-238.
  15. Gotsis A., Spiccia L. and Montgomery K.C. (1992) Application of Cr(III) hydrolytic oligomers in leather tanning. Part 1. Effect of sulphate on the tanning properties of dimer and trimer, *J.Soc.Leaner Technol.Chem.*, **87**, 195-200.
  16. a) Selvarangan R. and Nayudamma Y. (1964), Alum tannages: Part II. Tanning action of basic aluminium salts, *Leather Sci.* **11**, pp. 431-439;  
 b) Slabbert N.P. (1981), Mimosa-Al tannages – An alternative to chrome tanning, *J. Am. Leather Chem. Assoc.*, **76**, pp. 231-244.
  17. Covington A.D., (1998), New tannages for the new millennium, *J. Am. Leather Chem. Assoc.*, **93**, pp.168-182.
  18. Shuttleworth S.G (1950), The theory of chrome tanning, *J.Soc. Leather Technol. Chem.* **34**, pp. 410-435.
  19. Lollar R.M., (1978) The mechanism of vegetable tanning. In: The chemistry and technology of leather, (O'Flaherty F.O., Roddy W.T., Lollar R.M eds.), **2** pp 201-220.
  20. a) Heidemann. E. (1993), Practical and theoretical aspects of tanning. In: Fundamentals of leather manufacture, Eduard Roether KG. pp.269-294;

- b) Covington A.D., Lampard G.S., Hancock R.A. and Ioannidis I.A. (1998) Studies on the origin of hydrothermal stability: A new theory of tanning, *J. Am. Leather Chem. Assoc.*, **93**, pp.107.
21. Covington A.D., (1999) Innovations in processing. In.: Science and technology for leather into the next millennium, Tata McGraw-Hill Publishing Company., New Delhi, pp. 117-133.
22. Kedlaya K.J., (1987), Mineral tannages – Present status, *Leather Sci.*, **34**, pp. 33-41.
23. a) Anuradha B., Samivelu N., Ramesh R., Rathinasami V. and Chandrababu N.K., (1997) Full vegetable upper leather. In: Proceedings of the 32<sup>nd</sup> LERIG<sup>7</sup>, CLRI Chennai, PS-5;
- b) Covington A.D. and Shi B. (1998) High stability organic tanning using plant polyphenols. Part 1. The interaction between vegetable tannins and aldehydic crosslinkers, *J. Am. Leather Chem. Assoc.*, **82**, pp.64-71.
24. Puntener A. (1997) Ecology and modern leather production, *Leather*, Sep. 37-48.
25. a) Cassel J. (1959), Effect of gamma radiation on collagen, *J. Am. Leather Chem. Assoc.*, **54**, pp.432-451;
- b) Strakhov I.P., Levenko P.I. and Shifrin I.C. (1963), Influence of gamma irradiation on chrome upper leather, *Kozh.Obuvn.Prom.*, **5(7)**, pp. 20-23; c) Mohanakrishnan V. and Ramanathan N. (1967), Effect of gamma radiation on tanned collagen, *Leather Sci.*, **14**, pp. 347-359.
26. Ramasami T., Rao J.R., Chandrababu N.K, Parthasarathi K., Rao P.G., Saravanan P., Gayatri R., and Sreeram K.J. (1999) Beamhouse and tanning. Process chemistry revisited, *J. Soc. Leather Technol. Chem.*, **83**, pp.39-45
27. Rao J.R., Chandrasekaran B., Subramanian V., Nair B.U., Ramasami T., (1998), Physico-chemical and structural studies on leathers tanned using high exhaust basic chromium sulphate salt, *J. Am. Leather Chem. Assoc.*, **93**, 139-147.
28. a) Sharp B.W. (1981), Chromium recycling, *J. Am. Leather Chem. Assoc.* **76**, pp.24-34;
- b) Rao J.R., Chandrababu N.K., Rao P.S., Ramesh R., Suthanthararajan R., Nair B.U., Nair K.M., Warriar K.G.K., Rajamani S., Ramasami T., and Langerwerf J.S.A. (1999), Surveillance of chromium in tanning: A revisit. In: Science and technology for leather into the next millennium, Tata McGraw Hill Publishing Company, New Delhi, pp. 295-301;
- c) Money C.A. (1999), Clean technology challenges. In: Science and technology for leather into the next millennium, Tata McGraw Hill Publishing Company, New Delhi, pp. 284-294.
29. Gaughhofer J., (1986), Environmental aspects of tanning with chromium, **70**, pp.11-13.
30. Ramasami T. (1996), Greening of chrome tanning in Indian leather industry, *ILIFO J. Cleaner Tanning*, **1(2)**, pp.12-14.



# Future of Chrome Management

Bi Shi  
Dept. of Leather Engineering  
Sichuan Union University  
Chengdu 610065  
P. R. China

Contents	Page
1. Background	24
2. Principles of future chrome management	25
3. Analyses of current situation of chrome tanning	25
4. Suggestions for minimising environmental impact of chrome tanning	28
5. Preparations for undertaking the procedure	29
References	30

## 1. Background

It is not doubted that chrome tanning, as the preferred tannage, will continue for many years. The opinion is based on the observation that, although a number of alternative options have been suggested over recent several decades, none of them shows comprehensive advantages comparable to the well established chrome tanning process, in consideration of its practical manipulation, processing costs and particularly its versatility in the resultant leathers. On the other hand, even if a perfect alternative emerges in the near future, it might take us a long time to debate whether the new one is a more environmentally friendly choice. Our sector will not stop to wait for the conclusion of the argument. So, objectively, we should still pay attention to efficient management of chrome tanning.

The environmental impacts of conventional chrome tanning are caused by the unexhausted chemicals in the effluent and in leather wastes. This paper concentrates on discussions of solving the former problem.

The main pollutants in waste chrome tanning liquor include chromium(III) and sodium chloride. Using optimised operations in a conventional chrome tannage will still leave about 20-25% of the chromium(III) offer in the bath. Sodium chloride remaining in the float is about 6-8% based on limed pelt weight. These residues are certainly incompatible with

environmental provisions. Alkaline precipitation is an established way of recovering chromium(III). The high cost and slow running effects have resulted in the method effectively being abandoned. Recycling of chrome tanning liquor is working in some tanneries, but the requirements of precise controlling and additional equipment and operations make it difficult to be accepted by most tanneries.

In general, it is unrealistic to reject chrome tanning in the coming millennium, but it is equally true that we have to improve the management of chrome tanning, based on new scientific ideas which create changes acceptable to both the environmental and tannery sectors.

## **2. Principles of future chrome management**

The following three points should be kept in mind when we speculate about the technologies of minimising the environmental impact of chrome tanning.

1. The pollutants chromium(III) and sodium chloride should be, to a great extent, eliminated in the process itself, not by extra treatments.

2. The management of chrome should be combined with the modernisation of our sector. That is, cleaner technology should result in higher production efficiency, including lower cost, shorter operating times and easier control. Indeed, the modernisation of leather making is equally as important as the management of pollution, for the further development of our sector. Leather making is a very traditional industry often running with low productivity. Its potential to compete with other industries in the next millennium largely depends on its level of modernisation. Any cleaner technology, no matter how effectively it may minimise environmental impact, will not come into practice if it results in lower productivity or increases production complexity. From this consideration, neither chrome recovery by precipitation nor direct recycling represents the future of chrome management.

3. The leather produced by cleaner technology should have sound properties matching conventional chrome leathers.

## **3. Analyses of current situation of chrome tanning**

Critical analyses, based on scientific understanding of conventional chrome tanning, is the foundation for predicting new, more practical approaches to minimising the environmental impact of the process.

The predominant pollutants of chrome tanning are chromium(III) and sodium chloride. The latter comes from the conventional technique of pickling. Most of it is left in the float, since there is no substantive reaction between sodium chloride and collagen. Therefore, it is clear that the elimination of sodium chloride refers to a change of technique.

The amount of chromium(III) left in the residual float is due to the fact that typically only 70-80% of the chromium(III) offered associates with the collagen, even when so-called optimised conditions are applied. Such an equilibrium has been determined, by undertaking conventional chrome tanning at pH 2.5 to 4.0 in a way in which the carboxyls of collagen, the groups

responsible for its reaction with chromium(III), are not fully utilised . On the other hand, the kinetic and thermodynamic conditions for the reaction of the chrome tanning agent may not have been truly optimised, for the following reasons.

1. Knowing that only ionized carboxyls coordinate with chromium(III), their reactive probability in conventional chrome tanning-*can* be predicted. All the carboxyls on collagen come from sidechains of aspartic and glutamic acid residues. The pKa values for the carboxyls of aspartic and glutamic acid are 3.65 and 4.25 individually [1], so we can calculate percentages of ionized carboxyls of these two amino acids at different pH values, using the **Henderson-Hasselbach** equation:

$$\text{pH} = \text{pKa} + \log \frac{A}{1-A}$$

where A is the percentage of the ionized carboxyls . The results are shown in Tables I and II. Similarly, the ionisation of gelatine, the pKa of which is 4.15 determined by potentiometric titration, is shown in Table III [2]. The actual situation in pelt collagen should be quite similar to those model situations. That means we may have, on an average, less than 50% of the carboxyls in collagen participating in the reaction in conventional chrome tanning.

**Table I. Degree of ionisation of carboxyl of aspartic acid**

PH	Ionisation of carboxyls (%)	pH	Ionisation of carboxyls (%)
2.50	4.2	4.00	58.0
3.00	12.1	4.50	81.4
3.50	30.4	5.00	93.3
3.86	50.0	6.00	99.3

**Table II. Degree of ionisation of carboxyl of glutamic acid**

PH	Ionisation of carboxyls (%)	pH	Ionisation of carboxyls (%)
2.0	0.56	4.0	36.0
2.5	1.75	4.5	64.0
3.0	5.3	5.0	84.9
3.5	15.1	6.0	98.3

**Table III. Degree of ionisation of carboxyl of gelatin**

PH	Ionisation of carboxyls (%)	pH	Ionisation of carboxyls (%)
2.0	0.70	4.0	41.4
2.5	2.19	4.5	69.1
3.0	6.6	5.0	87.6
3.5	18.3	6.0	98.6

**Table IV. Compositional analyses of chrome tanning liquors during tanning<sup>a</sup>**

Tanning agents	Stage	Composition of chrome complexes (%)				
		negative and nonionic	+1	+2	+3	+4 and above
Chrome liquor <sup>b</sup>	tanning run 5 min <sup>e</sup>	18.6	19.4	9.8	29.4	20.7
	end <sup>f</sup>	33.2	38.5	12.6	10.6	1.0
Chromosal B <sup>c</sup>	run 5 min	45.7	23.4	14.2	12.0	-
	end	36.3	37.8	9.3	8.5	3.2
KMC <sup>d</sup>	run 5 min	80.8	11.4	4.3	-	-
	end	46.4	36.5	6.5	6.0	-

a. determined by ion exchange chromatography, Cr<sub>2</sub>O<sub>3</sub> offer 1.25%

b. b. alkalinity 36%, glucose reduced

c. c alkalinity 33%

d. d. alkalinity 33-36

e. e. start at pH 2.5

f. f. basified to pH4.0.

2. The tanning effect is mainly the result of the interaction between positive chromium(III) complexes and the ionised carboxyls of collagen fibres, particularly crosslinks between fibres. The reaction will seldom occur when the complexes are nonionic or negatively charged, since their probability of approaching carboxyls is less than for cationic species. Compositional analyses of some typical chrome tanning agents during tanning are listed in Table IV. The uptake of chromium(III) is indicated in Table V [2].

**Table V. Uptake of chromium (III)**

Tanning agent	End pH	Uptake of Cr(III) (%)	Cr <sub>2</sub> O <sub>3</sub> in waste float (g/l)	Ts (°C)
Chrome tanning liquor	4.05	67.7	2.02	92
Chromosal B	3.98	76.8	1.45	95
KMC	4.02	83.2	1.05	97

Considerable quantities of negatively, nonionic and +1 charged chromium(III) complexes are left in waste tanning liquors, showing that the kinetic parameters of temperature and pH in conventional chrome tanning are not really optimised as well.

#### **4. Suggestions for minimizing environmental impact of chrome tanning**

Practical cleaner technologies should including both a significant reduction of pollutants and a promise of increasing production efficiency, as emphasised above. Based on a scientific understanding of chrome tanning and comprehensive analyses of current researches and development in leather science, a discernible strategy for future management of chrome tanning is emerging. A future scheme of making chrome leather might be undertaken in the following processes:

**Soaking → Degreasing → Unhairing with H<sub>2</sub>O<sub>2</sub> → Bating → Chrome tanning  
(if necessary)**

The distinct advantages of the procedure are:

1. Chrome tanning at high pH range causes almost complete exhaustion of chromium(III) whilst sound chrome leather is still obtained, demonstrated by research [2-3]. As a result, further treatment of effluent might not be necessary. The option is scientifically reasonable, since ionisation of carboxyls on collagen sidechains is greatly promoted and at the same time molecular size and positive charge of chromium(III) complexes are increased. Both of the changes are favourable for the reaction. We know that only 10% of chromium(III) reacting with collagen forms crosslinks and thereby substantially contributes to the tanning effect in conventional chrome tanning. The distribution of carboxylic groups on collagen fibres is somewhat random. In such a system, it can be assumed that an increase of reactive groups to some extent might lead to an intensive increase in the crosslinking reaction. Consequently, the offer of chromium(III) and hence in the waste float could be further lowered.
2. Sodium chloride, one of the difficult pollutants, is eliminated with the elimination of the pickling process.
3. Hair saving unhairing using hydrogen peroxide not only reduces pollution, but also enhances the quality of leathers, if it is done properly [4-5]. Utilising this oxidant, the effects of both unhairing and swelling of collagen fibres can be achieved at the same time, so

traditionally used sulphide and lime are avoided . Therefore, the utilisation of uncontaminated solid wastes from the process becomes more convenient and versatile. This cleaner unhairing process might also promote uptake and fixing of chromium(III), as some researchers have observed [4-5]. It is understandable, because the unhairing is undertaken at pH 11-13, when the asparagine and glutamine can be hydrolysed into aspartic and glutamic acids. At the same time, some additional reactive groups taking part in coordination of chromium (III) might be derived during oxidising.

4. Water, chemicals, processes and time of processing can be reduced to approximately half, so the pressure on minimising pollution is also reduced. So, this is a method of reducing production costs and the way to modernise our sector.

#### **5. The preparations for undertaking the procedure**

In order for the ideal procedure, set out above, to come into practice as soon as possible, the following scientific and technological obstacles should be investigated.

##### **The mechanism of chrome tanning in high pH value**

The mechanism of conventional chrome tanning is broadly well known , but it might be quite different from that at high pH values. The pH changes roughly from 7.5 to 4.0 in high pH tanning. The compositions of typical chrome tanning liquors and their transforming kinetics in that pH range should be researched. Based on a firm understanding of the principles, proper controlling parameters for producing sound leathers of different styles can be established.

##### **The mechanism of hydrogen peroxide unhairing**

Research should be conducted into the influences of unhairing process on the swelling of collagen fibres, changes to the sidechain groups and damage to collagen. Amino acids and gelatine can be used as model compounds for the investigations. With the help of spectral analysis and histological studies, recognising the rules should not be very difficult.

##### **Equilibria of processes**

Here, the topics include the balances between the new processes, H<sub>2</sub>O<sub>2</sub> unhairing and high pH chrome tanning, and each process itself. Optimised parameters for high pH chrome tanning might be readjusted when used together with hydrogen peroxide unhairing, because the condition of pelts could be different from that of conventional ones. Correspondingly, the process of hydrogen peroxide unhairing faces the same problem. In addition to their fitting each other, extra adjustments can be applied by using suitable enzyme agents, but not only in the bating process.

The balance of each process mainly refers to utilising auxiliaries and pretreatments of the pelt, such as using surfactant for hydrogen peroxide unhairing or pretanning or even modification of collagen for high pH chrome tanning.

##### **Improvement of equipment**

Wooden drums are not appropriate for hydrogen peroxide unhairing as corrosion is rapid under these conditions. Stainless steel or plastic drums should be designed for the purpose,

preferably fitted with a hair separating device.

### References

- [1] Shun Tong, Wang Jinyan, et al. *Biochemistry*. High Education Press, Beijing, 1980:133
- [2] Li Guoying. Mechanism and technology of high exhaustion chrome tanning. Ph.D. Thesis of Sichuan Union University, Chengdu, 1999:17-27
- [3] S. Dasgupta.. Minimizing the environmental impact of chrome tanning with LASRA's "THRUBLU" processes. Proceedings IULTCS Congress, London, 1997:157-174
- [4] J.M. Morera, E.Bartoli, et al. Liming process using hydrogen peroxides. *J. Soc. Leath. Technol. Chem.*, 1997, 81(2): 70-73
- [5] Leather Engineering Department, Sichuan Union University . One Step Beamhouse Processing. Research Report, Chengdu, 1998

# **Future tanning chemistries**

**Anthony D. Covington  
British School of Leather Technology  
University College Northampton  
Boughton Green Road  
Northampton NN2 7AL, UK**

## **Abstract**

Tanning chemistry is discussed, with a view to establishing trends in practical and theoretical understanding, that allow prediction of where the future of tanning chemistry lies.

It is concluded that, whilst some improvements in chrome tanning and semi metal tanning can be envisaged, radical developments for future tanning chemistries will take place in the field of organic tanning. It is suggested that each of those types of tannage can benefit from considering the thermodynamics of interaction between the tanning agent and both the substrate and the solvent.

The options within organic tannage are to develop chemistries based either on the natural plant polyphenolics, including their derivatives, or on synthetic polymers or on a combination of the two. This view is supported and developed by considering the latest views on the theory of tanning, which endeavour to explain all known tanning reactions in terms of the effect of the matrix created around the collagen triple helix.

Some suggestions are presented for polyphenol-based tannages, both natural and synthetic, for synthetic tannages and for new crosslinkers. Speculation on more radical options for new tanning methods is included.



<b>Index</b>	<b>page</b>
Abstract	31
Index	32
1. Introduction	34
1.1. Mineral tanning	34
1.2. Chromium tanning	35
1.3. Semi metal tanning	35
1.4. Polyphenol tanning	35
1.5. Synthetic organic tanning	36
2. Recent advances	36
2.1. Mineral tanning	36
2.2. Chromium tanning	37
2.3. Polyphenol tanning	37
2.4. Semi metal tanning	39
2.5. Synthetic organic tanning	39
3. Tanning theory	39
4. Future tanning chemistries	41
4.1. Chromium tanning	41
4.1.1. Aqueous tanning	41
4.1.1.1. Thermodynamics	41
4.1.1.2. Crosslinking	43
4.1.2. Non aqueous tanning	44
4.2. Natural organic tanning	45
4.2.1. Semi metal tanning	45
4.2.2. Polyphenol tanning	46
4.2.3. Carbohydrate based tannages	47
4.3.4. Other organic reactions	51
4.3. Synthetic tanning	51
4.3.1. Synthetic polyphenol agents	51
4.3.2. Synthetic organic agents	54
4.3.3. Functional tanning agents	56
4.3.3.1. Acid/mordant dyes	56
4.3.3.2. Basic dyes	57
4.3.3.3. Direct dyes	57
4.3.3.4. Disperse dyes	58
4.3.3.5. Sulphur dyes	58
4.3.3.6. Other dye types	59
4.3.4. Crosslinkers	59
4.3.4.1. Aldehydes	60
4.3.4.2. Aldehydic crosslinkers	61
4.3.4.3. Nitromethane derivatives	62
4.3.4.4. Phosphonium compounds	63
4.3.4.5. Aromatic nitrogen heterocycles	64

4.3.4.6. Vinyl derivatives	64
4.3.4.7. Diazo linking	67
4.3.4.8. Oxygen heterocycles	67
4.3.4.9. Other chemical crosslinkers	68
4.3.4.10. Biochemical crosslinkers	69
<hr/>	
5. Future processing developments	70
5.1. Process prediction	70
5.2. Combination processing	70
5.3. Single step processing	71
5.4. Physical processing	71
5.5. Collagen modification	71
5.6. Unstable tannages	72
6. Overview	73
References	75

## 1. Introduction

Leather making is constantly changing, because it is expected to respond to the demands of the marketplace, often fashion driven, and the demands of environmental legislation, often politically driven: both require rapid response, flexibility of approach and an ability to anticipate trends. This paper aims to assist that anticipation, by examining trends and speculating about the future: it is an exercise in attempting to predict the future of the industry, at least for the first part of the new century.

The future of tanning will probably remain with chromium(III), because it is the tannage most suitable for modern leather making: it is versatile, simple, rapid and confers high stability with ease. Nevertheless, for an uncertain future, it is prudent to consider all other options. With the plethora of tannages already available, it is reasonable to query the need to attempt to produce more tannages and even to attempt to revolutionise the industry.

Tanning chemistry is a typical science: it is changing and developing all the time and will continue to do so, as long as there are leather scientists available and capable of undertaking the task. There are always improvements to be found and break throughs to be made. Within the subject of this paper, the challenge is to match the properties of chrome tanned leather; preferably this should be achieved with an organic tannage, in order to minimise environmental impact. Of those properties, high shrinkage temperature is the most difficult to achieve, but without it, modern shoemaking and clothing manufacture would be compromised. Therefore, tanning development is necessarily dominated by hydrothermal stability considerations.

But looking into the future requires an anticipation of the needs of industry and society, based on present trends. An example would be a response to the increasing trend for recycling products at the end of their useful life: a requirement in the 'cradle to grave' management of materials. In the case of leather, it is not clear how it would be recycled, in the conventionally understood sense of the term. Current thinking has not gone beyond the notion of recycling by incineration, to recover chrome and energy, or by partially decomposing the leather in preparation for composting. If high stability tanning by organic reaction develops, then it is possible to contemplate such tannages with built in specified instability to microorganisms. In this way, leather would be truly recyclable back to the earth, in an entirely ecological manner.

This is an apparent anathema to tanners, who have worked for thousands of years to develop tanning methods that confer high stability to collagen, to resist microbial attack. Now, it seems, the future of tanning may lie in the creation of unstable leathers.

### 1.1. Mineral tanning

In any discussion of the future of tanning, the relationship between chromium(III) and other mineral tanning options must be addressed. It can be assumed that a preferred alternative to chromium tannage would confer the familiar mineral tanned character, necessarily including the high hydrothermal stability needed for modern applications. However, such discussions are likely to be limited, since although there appear to be some viable candidates (1), it is recognised that there is no practical alternative (2). By applying the criteria of cost, availability, toxicity, most options are eliminated. If the additional criterion of effectiveness is introduced, the ability to elevate the shrinkage temperature of collagen above 100°C, then all

options fail.

It is possible that some way might be found to exploit the complex chemistry of the transition or the lanthanide elements, such as starting from less stable oxidation states. But there is no evidence that such an approach would work. As an example, titanium(III) is unable to resist forming oxy complexes, which characterise titanium(IV), during oxidation in situ in collagen; therefore, the difference in the chemistries of the different oxidation states is lost as the salt reverts to the stable oxidation state (3).

## 1.2. Chromium tanning

The tanning technology of chromium(III) is well understood, but the chemistry, in terms of the interaction with collagen, is less well understood (4). It is still not known with certainty where, within the hierarchy of structure, the putative 10% of bound chrome crosslinks the protein (5). Indeed, it is not known whether the proportion of crosslinked chrome can be manipulated by changing the tanning conditions, beyond the limited variability of optimising the process using conventional technology (6). It may be that the ratio of multipoint to unipoint fixed chrome is determined more by statistics, which depend on the availability of collagen chemistry reaction sites, than on process chemistry, which operates on chrome speciation and reaction rate. If that is the case, then there is a limit to the improvements that can be made to the tanning reaction, at least with regard to the effectiveness of the reaction.

More fundamentally, it is not certain what reactions take place at the molecular level: it has been assumed that the important reaction takes place at the carboxylates of aspartic and glutamic acids, where the reaction might be equivalent, modified only by the difference in pKa. However, there is evidence that these sites may not be equally reactive (7); reaction seems to be preferred at aspartate, presumably for entropic reasons, due to the longer chain of glutamate.

## 1.3. Semi metal tanning

The combination of metals and vegetable tannins is well established; the preferred reaction is between hydrolysable tannin or mimosa (since the important site is the pyrogallol moiety) and aluminium(III) (2). The reaction is rapid and very effective in producing high hydrothermal stability, so there appears to be little advantage in seeking improvements. However, both the advantage of the inherent stability of the system and the disadvantage of the undesirability of aluminium from perceived environmental impact, prompt some reconsideration.

## 1.4. Polyphenol tanning

Little has changed in recent years in the availability of natural plant extracts and the technology of applying them to collagen. Vegetable tannins are still applied in the conventional manner, with the intention of filling up the collagen structure, to confer weight and firmness, even to light leathers. They are not offered as precisely controlled chemical reagents, perhaps because the extracts are mixtures, not only of tannins, but of low molecular weight species, the non tans, and the high molecular weight species, the gums. Therefore, the tanner has to utilise this mixture, unable to optimise the reaction, for example with metal salts, by applying only the species that give the best reaction chemistry.

It has not been part of the extracting business to make modifications to the composition of the mixture, other than improving the dispersing and solubilising properties and, where necessary, reducing the astringency of the mixture. Nor have the producers of extracts attempted to separate out components of the mixture, other than maximising the tannin content. In this way, the vegetable tanning process has been made orders of magnitude faster than the traditional pit tanning of 'a year and a day'. But the chemistry remains fundamentally the same: the tanner chooses the tannin, whether gallotannin, ellagitannin or condensed tannin, to confer the properties he desires, then applies them at relatively high offer.

There is still some speculation regarding the nature of the reaction between these polyphenolic species and collagen. The latest thinking invokes the notion of preferential binding in the gap region of the quarter stagger structure (8).

### 1.5. Synthetic organic tanning

All tanners are familiar with the wide range of synthetic tannages available in the marketplace: these comprise aldehydes and aldehydic compounds or derivatives, the conventionally understood synthetic tanning agents, whether auxiliary, retanning or replacement syntans, polymers of different types, acrylic, urethane etc. The chemistries of these tanning agents are varied and they have useful variations in effect, but they all have one property in common: they are incapable of conferring a shrinkage temperature higher than about 85°C (9).

Despite developments in the chemistry of aldehydic tanning and the enormous strides in polymer development, no compound in this category of tannins has been found to offer useful solo tanning properties for high hydrothermal stability leather.

## 2. Recent advances

In order to predict the future of tanning, it is necessary to review the recently published advances in tanning science. Strictly, it is only the most recent scientific work that can point the way forward; technology is the application of established scientific principles and consequently lags behind the most innovative thinking, which drives change.

### 2.1. Mineral tanning

With the exception of a new study of iron tanning (10), which offers no advantages, but only the disadvantage of low stability, advances in mineral tanning are confined to mixtures of metal salts. All those mixtures without chrome produce low shrinkage temperature, but mixtures with chrome can have a positive effect on the chrome tanning reaction (11), see Section 2.2.

The only general reaction that has been shown to improve mineral tanning is the modification of collagen reactivity, by incorporating chelating reaction sites, using the triazinyl chemistry of reactive dyes, to fix the new polycarboxylate moieties covalently at amino groups. In this way, Holmes (12) has caused aluminium, zirconium and titanium tannages to produce shrinkage temperatures higher than usual, even reaching 100°C.

## 2.2. Chromium tanning

Developments in chrome tanning have been slow in recent years. Since the reaction is a two component system, there are three options for modifying the tannage. First, there is the option of making collagen more reactive: this can be achieved by incorporating additional carboxylate groups, using for example the Mannich and Michael reactions or glyoxylic acid (13-15). All such modifications of collagen chemistry are likely to cause unacceptable structural damage and the benefits have not been demonstrated, beyond some increase in chrome uptake.

The second approach is to influence the chemistry of the chromium. There was a brief attempt in the 80's to reintroduce an element of the two bath process chemistry into the industry, but that was unsuccessful, despite the effectiveness, because of the presence of chromium(VI). A more acceptable change to chromium reactivity is to use masking. The theory of masking is well understood, in terms of its effect on the technology of tanning. Incorporated into those ideas is the notion of increasing the reactivity of chrome by polymerising the molecular ions with polybasic carboxylate species. In this respect, the most interesting compounds are the aromatic polycarboxylates (16): in particular, mellitate (1,2,4,5-tetra carboxy benzene) can raise the shrinkage temperature of wet blue up to 130°C, a degree of hydrothermal stability that may be useful for future applications of leather.

Thirdly, the reaction itself can be accelerated, by pretreating the substrate: a catalytic effect is observed with aluminium(III) (4) or ethanolamine (17). Since the effect is postulated to depend upon a loose, entropically favoured interaction by the auxiliary species prior to chrome tanning, it is probable that other organic compounds and metal salts can exhibit the same effect. This seems to be the case for even more complicated reactions, involving mixed complexes of chromium(III) with iron(II), zirconium(IV) and titanium(IV) (11). Moreover, such complexes appear to exhibit an additional effect: it is possible to control the overall basicity of the mixture of metal ions, to have a different relationship with pH compared to chromium(III) alone. In this way, it may be possible to reduce the basicity of chrome at a given pH, thereby keeping the species small, whilst maintaining the collagen at reactive pH values.

## 2.3. Polyphenol tanning

The chemistry of the reactions between condensed tannins and aldehydes has been exploited for many years (18), but the first application to leather was described by Das Gupta, in the context of oxazolidine tannage (19). However, the reported results indicated only moderate shrinkage temperature when the reaction was controlled by pH adjustment. Recently, it was shown that, if the reaction is driven by heat at a pH value conducive to reaction by both vegetable tannin and aldehydic reagents, which have mutually exclusive requirements, then very high stability can be easily achieved (20). The reaction applies to condensed tannins, not to hydrolysable tannins: in the former case, the reaction might be considered to be analogous to the crosslinking of hydrolysable tannins by metals, although the chemistries are unrelated. The reaction between hydrolysable tannins and aldehydic reagents is competitive for reaction sites on collagen and the interaction results in a negative synergy (21).

It was shown that the preferred tannin for this organic tannage is mimosa. By making some assumptions about the structure of the reactive species in mimosa extract, it was calculated

that the optimum shrinkage temperature is reached when each triple helix is bound to 75 moles of mimosa and 225 moles of oxazolidine (21). If the triple helix has one twist per three amino acid residues, then there are about 1,000 peptide links on the outside of the structure. If each reactive mimosa species is a pentamer, the polyphenol provides about 380 flavonoid units by which it can be attached to the collagen structure. The stoichiometry is feasible, as is the molar ratio of bifunctional oxazolidine to mimosa. The overall effect means that the collagen is barely covered with polyphenol molecules, each of which is linked to the protein via up to thirty hydrogen bonds and crosslinked to other polyphenol molecules by three crosslinks: so, the resulting polymer is crosslinked in at least two dimensions, rather than linearly in one dimension.

Using catechin as a model for condensed tannins, it has been shown that the crosslinking reaction with oxazolidine takes place exclusively at the 6- and 8-positions in the A ring; no reaction could be detected at the catechol B ring (22). The relative reactivities of these centres were confirmed in a study of model polyphenols (7): the tanning effect of the reaction was studied by crosslinking simple di- and trihydroxy benzene compounds with oxazolidine, in the presence of sheepskin collagen. The results are presented in Table I.

Table I. The tanning reaction of polyhydroxy benzene compounds (0.18 mole% offer, equivalent to 20% dihydroxybenzene) crosslinked with oxazolidine (equimolar offer).

Hydroxy benzene	T <sub>1</sub> <sup>a</sup> (°C)	T <sub>2</sub> <sup>b</sup> (°C)	T <sub>3</sub> <sup>c</sup> (°C)	Predicted T <sub>3</sub> (°C)	Measured T <sub>3</sub> (°C)	Synergy (°C)
Hydroxyquinone (1,4-dihydroxy)	69	16	43	96	79	-17
Catechol (1,2-dihydroxy)	60	7	34	87	77	-10
Phloroglucinol (1,3,5-trihydroxy)	63	10	37	90	97	+7
Pyrogallol (1,2,3-trihydroxy)	58	5	32	85	96	+11
Resorcinol (1,3-dihydroxy)	56	3	30	83	115	+32

<sup>a</sup> effect of hydroxy benzene alone

<sup>b</sup> compared with raw pelt, T<sub>s</sub> 53°C

<sup>c</sup> T<sub>s2</sub> = 27°C, the effect of oxazolidine alone

It is clear that the most reactive moiety is the 1,3-dihydroxy arrangement, affording the greatest degree of tanning synergy, indicating the greatest propensity for crosslinking at the aromatic carbons.

Part of the assumption in the calculation briefly described above concerns the structures of the main components of mimosa tannin, of which there are two: one is the structure of the main component of quebracho, a typical catechol tannin and the other is the gallotannin derivative, ie the B ring contains the pyrogallol group, rather than the catechol group. Since quebracho does not crosslink well with oxazolidine, it may be assumed that the active ingredient is the gallotannin species. It may be further postulated that the enhanced reactivity of mimosa

derives from the presence of the pyrogallol group, allowing additional reaction at the B ring. This reactivity is well known in model compounds and attempts have been made to exploit it for tanning (23,24), but by choosing to use pH rather than temperature to drive the reaction, only moderate shrinkage temperature was achieved. A better result was obtained, again at low temperature but elevated pH, by crosslinking resorcinol with an addition compound of acrolein and formaldehyde (25), producing a shrinkage temperature  $>100^{\circ}\text{C}$ .

#### 2.4. Semi metal tanning

It has recently been shown that titanium(III) has some advantages in this respect compared to aluminium(III) (7), so other less conventional metal salts may prove to be useful in this tanning. Here, the advantage lies in a reduction in strength loss, which typically accompanies these filling tannages. It remains to be seen whether the preliminary indications of advantage extend to stabilising the leather to the action of light and other environmental degradative effects. Furthermore, the introduction of a new metal retannage begs the question as to whether there might be an optimum system of natural or synthetic polyphenol to go with the titanium(III), see below, Section 4.2.1.

#### 2.5. Synthetic organic tanning

Many synthetic organic tannages are familiar to tanners, who recognise that all confer only moderate hydrothermal stability (9). In the case of polymeric resins, this seems to apply both to using the polymer itself or to preparing the polymer in situ in collagen: specifically, this is the observation for melamine-formaldehyde tanning (26).

But it has been shown that some synthetic organic tannages are capable of producing boilfast leather: some melamine-formaldehyde resins can be crosslinked with aldehydic agents, driving the reaction with heat (20,27). Not all resins are suitable and not all aldehydic crosslinkers are effective. There appears to be a particle size requirement and it is a feature of these polymers that they are composed of small particles, aggregated together, which break up upon heating and the particle size distribution depends on the temperature. Therefore, the optimum temperature of the reaction is determined by the temperature at which the dominating particle size is about 80nm. The preferred crosslinker for the reaction is tetrakis hydroxymethyl phosphonium sulphate, see Section 4.3.4.4.

### 3. Tanning theory

An underlying feature of the tannages covered in Sections 1 and 2 is the variation in the effects of different tannages on shrinkage temperature and the apparent paucity of reactions capable of producing high shrinkage temperature. In order to rationalise these differences and to determine if it is true that high shrinkage temperature is a specific or general property of tannages, it is necessary to develop a comprehensive theory of tanning.

Such a theory has been proposed (28), to explain the effects of tanning in terms of the degree of structure imposed by the tanning chemistry. More recently, that view has been revised and extended, to incorporate the concept of matrix formation around the triple helix (29). The principles of the generalised theory can be summarised as follows.



1. Shrinking is a typical chemical reaction, so it can be treated thermodynamically: note, the reaction is thought to involve the breaking of hydrogen bonds, part of the collagen structure, but not breaking the tannin-collagen bonds.

2. The Hammond postulate states that, for an endothermic reaction, the free energy of the reaction is close to the free energy of activation. Therefore, the rate of the shrinking transition, upon which the shrinkage temperature depends, can be related not only to the activation parameters but also to the thermodynamic parameters of the equilibrium, so:

$$-\ln k \approx \frac{\Delta H^\circ}{RT} - \frac{\Delta S^\circ}{R} \quad \text{eqn. 1}$$

This means that the tanning reactions can be analysed in terms of the known chemistries of reaction, defining the products, with the assumption that the changes impact directly on the rate of shrinking and hence on the shrinkage temperature. So it is not necessary to speculate about the nature of the transition state, in order to discuss the kinetics. This simplifies the view of the effect of tanning reactions on the collagen. It can be seen that elevation of the shrinkage temperature depends on an increase in the enthalpy of the system and a decrease in the entropy of the system.

3. The 'reactant' in the shrinking reaction is a 'cooperating' unit of structure: in simple tanning chemistries, the shrinkage temperature is directly proportional to the size of this moiety. For multiply bound species, the shrinkage temperature is independent of the size of the cooperating unit.

4. The entropic contribution to hydrothermal stability is universal for all materials which interact with collagen; the effect operates for a wide range of tanning agents, causing the shrinkage temperature to vary up to about 85°C.

5. The enthalpic contribution to hydrothermal stability is a reflection of the degree of additional structure imposed by the tanning on the collagen. This is the source of high shrinkage temperature.

6. 'Imposed structure' can be defined in terms of obeying the following rules:

- there must be a high energy, non labile interaction between the collagen and the primary reactant: the bonding should be preferably at least partially covalent or multiple hydrogen bonded. The reaction energy must be maximised, consistent with optimising the size of the molecular species.
- the crosslinking should be rigid and short, to impose the highest degree of structure, but in this context, multiple hydrogen bonding does not by itself confer structure.
- in the case of multiple hydrogen bonding (typically for organic tanning), the structure making effect is achieved by creating a rigid matrix, by crosslinking in situ. The criteria for successful crosslinking are the same as for primary crosslinking, with respect to the nature and rigidity of the crosslinking. Hence, the crosslinker must have

greater affinity for the substrate than for itself. This is exemplified by the tendency for aldehydes to form polymeric species, depending on the reaction conditions.

- the nature of the matrix can be generalised in terms of the creation of a rigid matrix around the collagen, which may incorporate the supramolecular water around the triple helix as part of its structure. The matrix can be constructed in the form of a covalently linked meshwork, that may disrupt or even displace the supramolecular water, because of its higher energy reaction with collagen. If there is no extensive meshwork formed by the tanning interaction, then for high hydrothermal stability, the matrix must incorporate the supramolecular water as the additional level of crosslinking.

In this newest form, the theory is entirely inclusive of all known tanning reactions, both inorganic and organic. The rules of the theory allow all known tannages to be rationalised, with regard to their effect in raising the shrinkage temperature of collagen. Conversely, knowledge of the rules allows prediction of many high hydrothermal stability tannages: it is clear that this is not a property of a few specific chemistries, but is a general property of tannages which conform to the rules. In other words, there will be many chemical systems capable of producing leathers with shrinkage temperature  $>100^{\circ}\text{C}$ .

## 4. Future tanning chemistries

### 4.1. Chromium tanning

Improvements to chrome tanning chemistry are likely to occur within two different approaches to the process, based on the role played by the solvent.

#### 4.1.1. Aqueous tanning

##### 4.1.1.1. The thermodynamics of tanning

It has always been assumed that tanning processes (and any other processes involving reactions which chemically bind reagents to collagen) are controlled by the chemistry of the reaction alone; partitioning of reagents between the solvent and the substrate, which incorporates the notion of transport between media, has not been considered. This new factor can be expressed as follows:



The reagent is partitioned between the solvent and the substrate, in the same way as a solute is partitioned between two solvents in the familiar solvent extraction procedure. In a heterogeneous reaction such as tanning, the partition coefficient depends on the relative thermodynamics of the solvation and the affinity of the reagent for the substrate. Therefore, if the solvation is made less favourable, the reagent is forced to interact with the substrate, a prelude to chemical reaction. Another, more rigorous way to look at the system is in terms of the free energy of transfer,  $\Delta G_t^{\circ}$ , from the solvent to the substrate (30). By analogy with the concept of preferential solvation in a mixed solvent system, a reagent can interact with both components of the system, the solvent and the collagen: this should be amenable to a

thermodynamic analysis.

An example of preferential interaction in operation is the selective use of masking agents. It has long been recognised that phthalate masking is a powerful method of making chrome more reactive and enhancing the rate of fixation. It has been assumed, by analogy with crosslinking aliphatic polycarboxylate masking, that the effect is to make the chrome species bigger. However, this is sterically unfavoured, it is easier and entropically favoured for the complex to be a chelate. The effect is indicated in some figures for chrome uptake (31) and in more recent model studies, using aluminium(III) salts, in which higher shrinkage temperature is achieved with phthalate or maleate masking than with fumarate masking (32), shown in Table II.

Table II. The effect of masking agent on metal salt reactivity in tanning.

Masking salt	Relative chrome uptake	Shrinkage temperature of aluminium tanned collagen (°C)	Time of hot resistance of aniline sensitive aluminium tanned collagen (min)
None	1.00	-	-
Fumarate	-	65	5
Maleate	1.40	80	15
Phthalate	1.93	92	20

It can be surmised that phthalate and maleate form chelates, but fumarate is only capable of forming crosslinks between metal ions. The inference is that the reaction is influenced by the hydrophobicity of the complex, which is higher with chelated complexes, causing the metal salt to be driven out of aqueous solution onto the substrate.

The effect might be exploited by varying the hydrophobicity of chrome during the reaction, making the metal more reactive as the reaction proceeds. This could be done by introducing conventional masking agents, familiar to tanners, or by using more novel masking agents which confer a higher degree of hydrophobicity. Alternatively, masking agents which can be applied at the start of tannage or used in the preparation of the tanning salt and become progressively more hydrophobic during the reaction would constitute a 'smart' tanning salt. The mechanism for changes to chrome reactivity is less clear, but the masking agent could include an element of its structure that is hydrolysed during tannage, to reduce the hydrophilicity. Alternatively, this might be achieved by a redox reagent or enzyme attack, for example by an esterase. A putative example of the principle is presented in Fig. 1, in which a hydrophilic, monodentate masking ligand can be converted to a chelating masking agent, which makes the chrome complex more hydrophobic.

Fig. 1. Hydrophobising chromium(III) species.

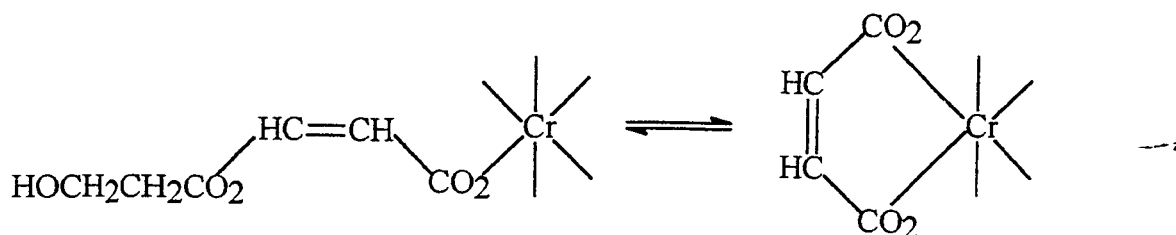

The role of solvent-solute interactions has already found application in dyeing. The rates of reaction of dyes in a mixture are more uniform if their hydrophilic-hydrophobic properties are matched, for example in the Sellaset range. Recently, Zaliauskiene measured the thermodynamic parameters for some dyeing reactions and found energetically more favourable uptake with more hydrophobic dyes: moreover, there was better dyeing when there was some matching of the hydrophilic-hydrophobic properties of the substrate (33).

The role of solvent properties to influence solubility is exploited in other processes. For example, the function of adding sodium chloride to the bath towards the end of the reactive dyeing process is to increase the ionic strength of the aqueous solvent, according to the formula:

$$I = 0.5 \sum_i c_i z_i^2 \quad \text{eqn. 2}$$

where:  $c_i$  is the  $i$ 'th ion, carrying charge  $z_i$ . Increasing the ionic strength of the solution has the effect of making it more polar, consequently driving the relatively hydrophobic reactive dye out of solution onto the substrate.

Efficient manipulation of the ionic strength, possibly also exploiting the properties of multiply charged electrolytes and their pH properties, will form an aspect of future processing procedures. Clearly, such an approach will also embrace membrane and reverse osmosis technologies, because it will be necessary to avoid contributing to the total dissolved solids (TDS) loading in the effluent by recycling the electrolyte.

The converse to this discussion is the influence of the substrate, in terms of its affinity to the solvent and to reagents, which vary in their hydrophilic/hydrophobic characteristics. It may be a fruitful area of research to investigate the relationships between the natures of the reactants in leather making process steps and the efficiency and effectiveness of the reaction. In effect, the processes and products may be significantly improved by more careful choice of the type and addition order of reagents in post tanning processing.

#### 4.1.1.2. Crosslinking in chrome tanning

With regard to more familiar aspects of the chrome tanning reaction, the question of where reaction occurs is worth considering. It has been assumed that reaction takes place at the carboxylate groups of aspartic and glutamic acids and that reaction is equally possible, bearing in mind the small difference in pKa (34). However, there is evidence that reaction is preferred

at the shorter chains of aspartic acid residues (7), presumably for entropic reasons. Therefore, there are two inferences that can be drawn.

1. From the new tanning theory, the reactions that increase the availability of carboxyl groups by reacting compounds with the amino groups of lysine make relatively unreactive sites, because the chain is already four methylene groups long. Furthermore, any crosslinks would not contribute structure to collagen, so would not contribute significantly to raising the shrinkage temperature.

2. The only way to increase the availability of effective crosslinking sites is to increase the number of aspartate carboxylates. This can be achieved in three ways. Firstly, liming causes the amide groups of asparagine and glutamine to be hydrolysed to aspartic and glutamic acids. Typical liming only converts about half of them and it is assumed that they are equally reactive in this respect. But, there is a danger of damaging the collagen if the conventional liming period is extended beyond 24 hours (35). Secondly, general amidases will convert both types of amide group, but the increase in glutamic acid may hinder the improvement in crosslinking opportunities. Thirdly, the specific enzyme asparaginase may be the answer, applied in the earliest stages of processing, during soaking (36).

#### 4.1.2. Non aqueous tanning

Part of the problem of achieving high chrome tanning efficiency, in terms of uptake onto collagen, is the affinity of the tanning salt for the aqueous medium, discussed in Section 4.1.1.1. One way of altering the thermodynamics of the system would be to change the solvent. An extreme example of the partitioning effect is the use of non aqueous solvent for chrome tanning; using paraffin as the tumbling and heat transfer medium for wet pelt, added chrome has no affinity for the solvent, so solubilisation within the pelt is rapid and complete (37).

The drawback to this approach is the use of organic solvent: although it is not impossible to devise an efficient way of handling such solvents, it would be preferable to use an alternative type of solvent. Super critical carbon dioxide is increasingly commonly used in industry for a variety of applications and it has already been used in the leather industry, as a degreasing method for sheepskins (38). It is only a short step to applying this technology to other processes, such as tanning. There are two problems: firstly, the conditions of high pressure require specialised equipment, with attendant hazards, secondly, the equilibrium between water within the pelt and the solvent may result in the reaction taking place under virtually anhydrous conditions. This second point requires investigation, since water plays a part in the complexation mechanism (39). It is possible that this would be an alternative method of getting the chrome into the substrate, but there would be a second step for fixation. It is clearer that such a solvent would have application to those steps which do not rely on an ionic mechanism, particularly some syntan retanning, dyeing and fatliquoring reactions; indeed it is possible to imagine a single step post tanning process, with no effluent, see Sections 5.2 and 5.3.

If non aqueous tanning is a realistic option, it opens up the possibility of radically changing the chrome tanning reaction: for example, chromium(II) may offer benefits as a starting material, since the complex chemistry is significantly different (40). In addition, some otherwise too

reactive organic tannages would become feasible, see Section 4.3.4.

## 4.2. Natural organic tanning

This section refers to those tannages based, however loosely, on plant extracts, that is polyphenol chemistry. Therefore, this covers tannages using intact vegetable tannins, derivatives or models, crosslinked in any way.

### 4.2.1. Semi metal tanning

In this context, improvements relate to the properties of the leather other than shrinkage temperature, since adequate hydrothermal stability is easily achieved. The process might be reviewed, to create a precise chemical process, rather than the conventional, two step process, in which metal retanning follows conventional vegetable tanning. In order to move away from what is now no more than a high stability modified vegetable tannage, it is necessary to be precise in the way the reagents are applied.

The requirements of the reaction are: the presence of pyrogallol groups (the catechol groups of condensed tannins are less effective) and a metal salt with high affinity for phenolic hydroxyl groups. Therefore, all hydrolysable tannins are eligible. But the astringency of these polyphenols can be high, so any reduction in the offer can lead to problems of inadequate penetration; although there are several solutions to the problem, which include sytan or aldehyde pretannage. The exception, with regard to tannin type, is mimosa, which is effective because it contains a major component which has a pyrogallol group as the B ring. Clearly, mimosa would be more efficient if this component was isolated from the rest of the less reactive components. It is possible that the ability of mimosa to react with collagen partially covalently (41) contributes to its powerful semi metal tanning reaction.

The semi metal reaction has not been reviewed extensively with regard to the relative reactivity of the tannins towards metal salts: for example, it is not known whether there is a marked difference between the gallotannins and the ellagitannins and such an experimental comparison might yield useful new tannages.

There are several metals which can be used in this reaction and the literature contains many examples. However, if a future tannage is to rely in any way on a metal salt, the environmental considerations become important. Aluminium(III) is recognised as having the most powerful affinity for phenolic hydroxyls, but from a position of perceived environmental impact, it may continue to be unacceptable. Nevertheless, further study of semi alum chemistry might reveal better tannages that minimise the use of aluminium salts and improve the binding, to minimise leaching of metal from the leather. It is certainly true that the reaction between polyphenols and aluminium(III) is powerful, so it is very easy to achieve shrinkage temperatures greater than 110°C. Consequently, there has been little incentive to examine the parameters of the reaction in any detail. Novel approaches may yield interesting results, for example using the breakdown products of zeolite, sodium aluminium silicate (32), where some control can be asserted on the size and nature of the aluminium species in solution, by controlling the amount and type of acid used to decompose it.

Of the remaining options, it is probable that titanium and zirconium could be used.

Titanium(IV) has a traditional role in this type of leather: potassium titanyl oxalate used to be the preferred retanning agent for making hatbanding leather. Titanium(III), with its acidic nature, is capable of being stabilised by carboxylate masking agents (3) and its simpler structure compared to titanium(IV) have already shown strong indications of offering an improvement to currently familiar semi metal tannages. Zirconium(IV) can react well with polyphenols: toxicity is low, available resources are large, so cost is likely to be controlled by the nature of the salt supplied for the purpose. Although not studied to any great extent, the use of the rare earth sulphate salts may produce useful leathers.

#### 4.2.2. Polyphenol tanning

Conventional vegetable tanning relies for its effect on reacting collagen with polymeric species of the right molecular weight: below 500 daltons the 'non tans' species are too small to interact strongly enough via their limited number of hydrogen bonding sites, above 3,000 daltons the 'gums' (higher polymers, associated with sugars) are too big to diffuse into the structure during the typical tannage, between 500 and 3,000 daltons the 'tans' are highly astringent, but small enough to penetrate and big enough to produce the filling effect that is required for traditional vegetable tanned leathers. Since vegetable tanning has been developed over centuries, it is reasonable to suppose that there are limited options for improving the process.

If we are to consider future processes that can be based on the sustainable resource of plant extracts, then there are several possibilities that may be proposed.

1. Since it has been shown that the pyrogallol group is more reactive than the catechol group, more appropriate condensed tans would be obtained from conventional sources if a way were to be found to oxidise the more common catechol B ring to a pyrogallol ring, perhaps with a phenol oxidase.
2. If the primary requirement is to crosslink small species in situ, it is possible that the non tans might be more useful than the tans in this context. Therefore, it would be an advantage to use those flavonoid extracts that contain high levels of low molecular weight components.
3. The species that might form the basis for high stability tannages are catechin (or epicatechin) or preferably gallicocatechin (or epigallocatechin), see Fig. 2: these species are obtainable from plants, but may also be obtainable from breakdown products of extracts or by synthesis.
4. For crosslinking tannages, it might be an advantage to break down the gums and the tans to lower molecular weight species: this might be done chemically or biochemically. It is known that the interflavonoid bond of the 3,5,7,3',4'-pentahydroxyproanthocyanidins is labile (42), so lower molecular tans can be made and relatively useless high molecular weight gums might be decomposed (split from the sugar) and depolymerised into more useful compounds.
5. The most effective way to exploit the reactivity of these new chemistries would be to find a source of prodelphinidin plant polyphenols. None of the currently well known vegetable tannins are of this type. However, there is a less well known source: pecan nut shell pith (43). Whilst a product has been made from this waste material, the only tannin produced in the

USA, it has not been widely marketed into the world's leather industry. The potential of the extract has not been explored, except as a wood glue. It has low molecular weight, corresponding to 3-5 flavonoid units, containing about 6 moles of prodelphinidin to 1 mole of procyanidin, depending on the extraction procedure, so the potential for organic tanning is enhanced. Although present experience indicates that the preferred crosslinker is oxazolidine, the role of the crosslinker must be reviewed, since it is not certain that optimum crosslinking is independent of polyphenol structure.

Fig. 2. The monomers of condensed polyphenols, the flavonoid structures.

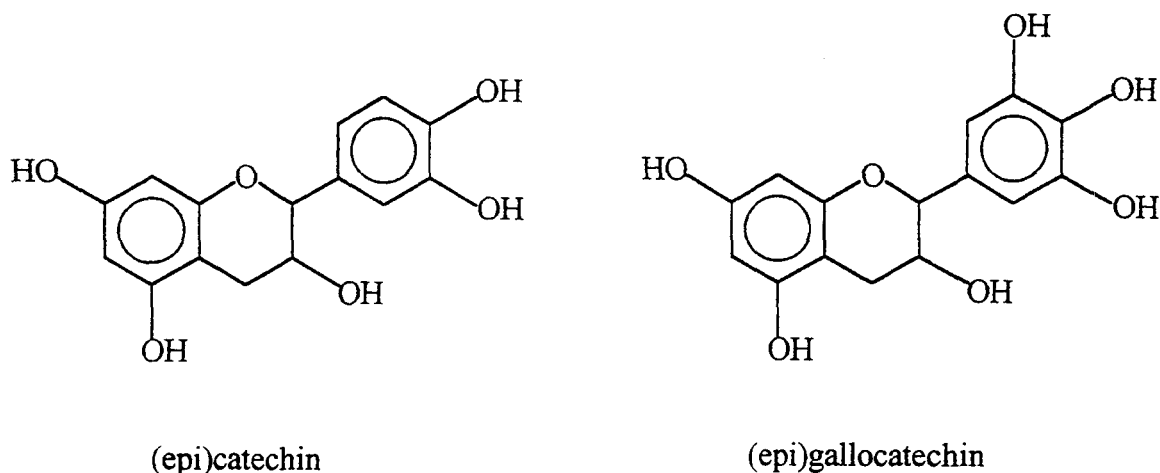

#### 4.2.3. Carbohydrate reactions

This class of tanning reagents starts with aldehyde derivatives of carbohydrates, exemplified by the well known starch dialdehyde, obtained by oxidation of starch with periodic acid (44), illustrated in Fig. 3.

Fig. 3. Ring opening of carbohydrate by periodic acid, to form a dialdehyde derivative.

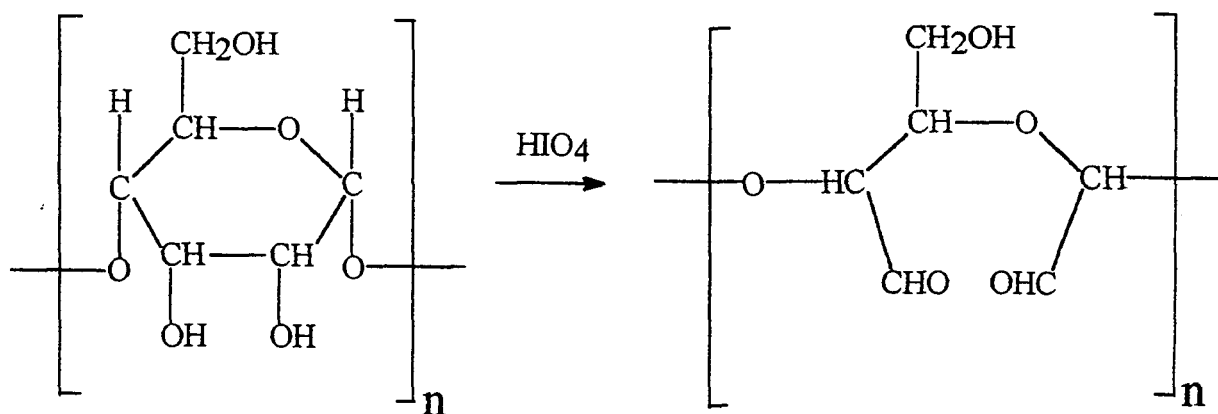



Starch is a large polymer and the eventual length of the dialdehyde compound can be controlled by the degree of oxidation; ultimately the oxidation can achieve 100%, when every glucose unit is opened up to create the shortest chain.

Other carbohydrates can undergo this reaction. Dextrin can be used in this way (45), since it is a carbohydrate chain containing 11-12 glucose units, usually obtained as an intermediate product of the hydrolysis of starch. A comparison of the tanning properties of these reagents claims the following results (45):

dialdehyde starch	Ts	62-74°C
dialdehyde dextrin	Ts	~72°C

Komanovsky has effectively generalised these reactions in his studies of the reactions within collagen at low moisture contents (46). The basis of the formation of permanent bonds is the Maillard reaction, shown in Fig. 4. The reaction depends on reducing the moisture content, in order for the groups to become close enough together to react, and works better at higher temperature and lower pH (in contrast to typical aldehyde tannage, which operates at high pH). It is suggested that sources of the glucosic material for this reaction could be sugars or the glycosaminoglycans, hyaluronic acid and dermatan sulphate proteoglycan. It is assumed that the ketoamine product, shown in Fig. 4, can react further with collagen to form a crosslink, but the structure of such a crosslink is unknown.

Fig. 4. The Maillard reaction, as applied to reaction with collagen.

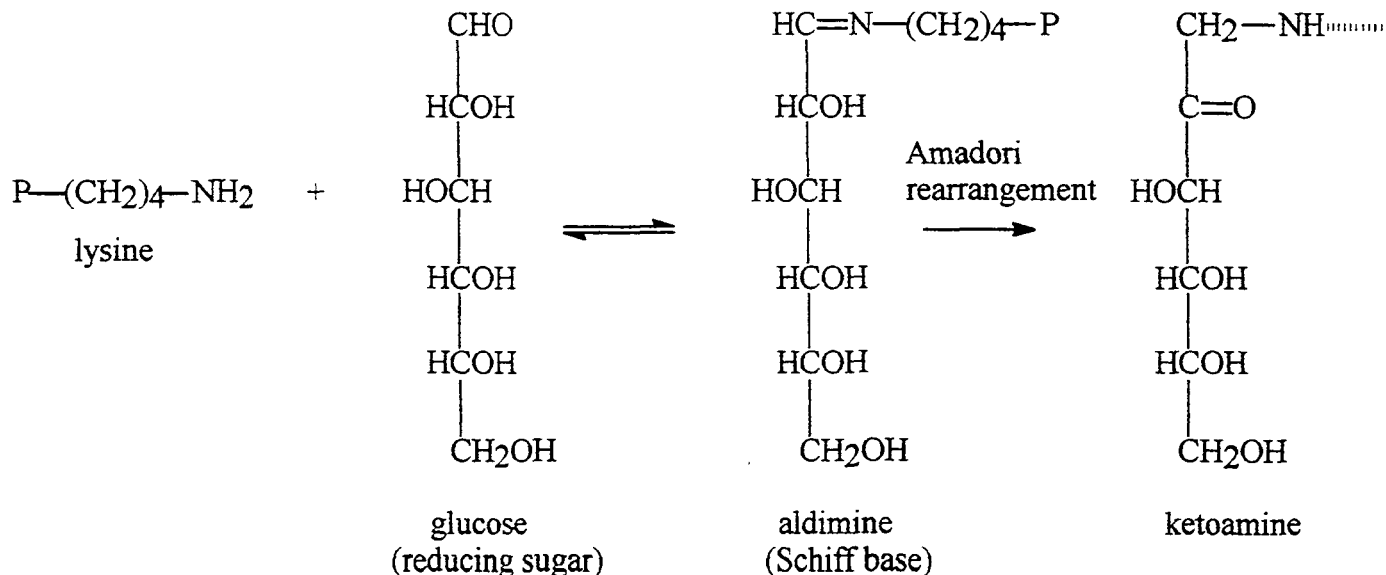

This chemistry raises the possibility of exploiting those components in a new tannage. Glycosaminoglycans are present only in small quantities, a fraction of one per cent on collagen weight, so the effect may not be commercially useful, unless additional compound is used. Dermatan sulphate proteoglycan is less likely to be applicable, because of its structure and

because it is bound within the gap region around fibrils. On the other hand, hyaluronic acid is found in solution within the fibre structure, and takes the form of a polymer, shown in Fig. 5. Tannages based on oxidation products of hyaluronic acid could form the basis for making hypoallergenic leather and modified collagen for sausage casings or modified recovered protein products, including meat products.

Fig. 5. The structure of intact hyaluronic acid.

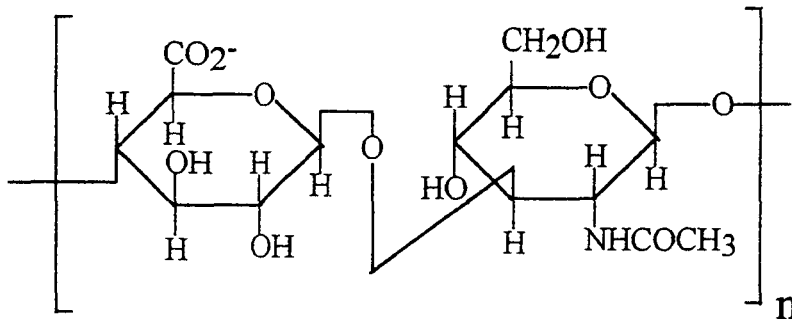

A stabilising process for protein that has not previously been reviewed in a tanning context is the preservation of so called bog bodies (47). Contrary to popular belief, the preservation mechanism is not a version of vegetable tanning. The environment in which the tissues are preserved is typically a sphagnum peat bog; the effect is thought to be due to a Maillard reaction between free amino groups in the proteins and reactive carbonyl groups in a soluble glycuronoglycan, sphagnum, containing residues of D-lyxo-5-hexosulopyranuronic acid (48). Sphagnum is a pectin-like material, bound covalently to cellulosic and amyloid chains in sphagnum moss; it is liberated by hydrolysis, as the moss turns into peat. Sphagnum resembles periodate oxidised polysaccharides: here, the variability in chain length may optimise the crosslinking possibilities, giving rise to effective tanning in terms of effective preservation, although the shrinkage temperature is low. The postulated reaction scheme is presented in Fig. 6.

It can be seen that these apparently different tanning mechanisms are all examples of similar chemistries, which depend for their effect on reaction with the basic sites on collagen. Hence, none of the variations is capable of producing high shrinkage temperature. However, the differences in leather properties may provide additional options for product applications.

Fig. 6. Reactions of decomposition products from sphagnum moss.

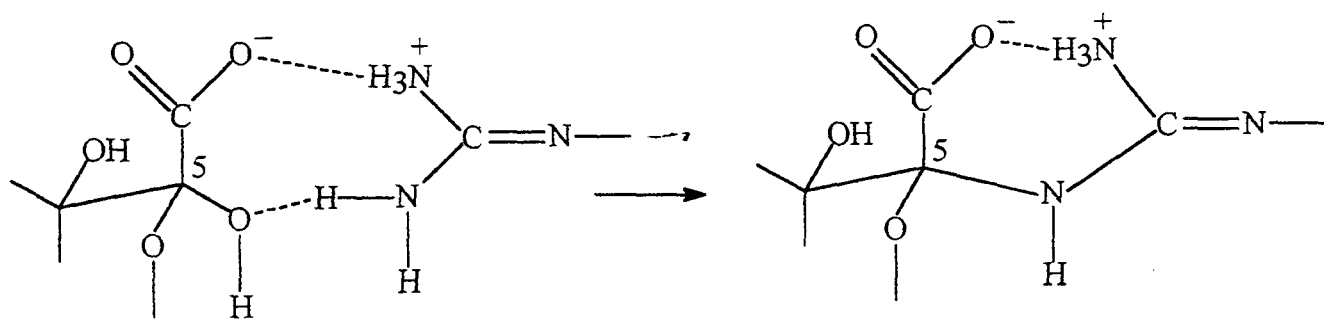

5-position in  
D-lyxo-5-hexosulo-  
pyranuronic acid

guanidino group  
in arginine

glycosylamine

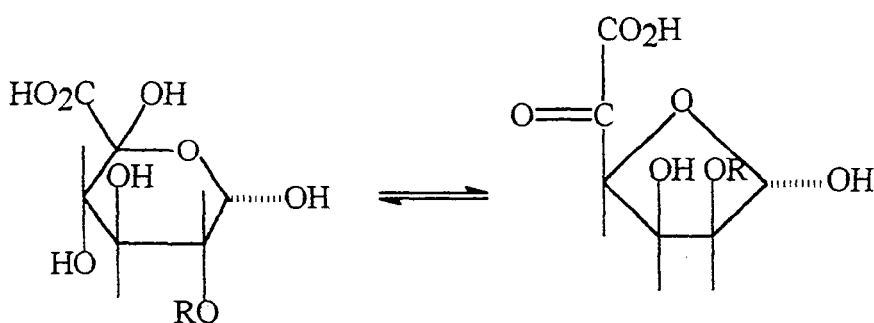

D-lyxo-5-hexosulopyranuronic acid

D-lyxo-5-hexosulofuranuronic acid

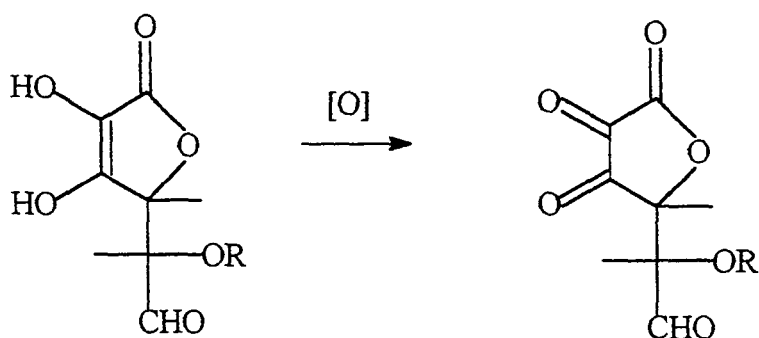

analogue of  
ascorbic acid

analogue of  
dehydroascorbic acid  
- resembles ninhydrin

#### 4.2.4. Other reactions

Another potential source of usefully reactive compounds derived from plant cell walls is ferulic acid (49). Interestingly, ferulic acid is a major breakdown product of lignin, so it may be possible to achieve what has long been sought by the combined efforts of the paper and syntan producers, that is to make a product from lignin that is useful to the leather industry. Ferulic acid itself can be polymerised by laccase, to form insoluble species and this might be the basis for a tanning reaction. Also, ferulic acid is converted by fungal species to other compounds which clearly have reactivity towards collagen, given in Fig. 7. In this case, reactivity does not depend on the basic groups in collagen, but can exploit the covalency aspect of polyphenol tanning.

Fig. 7. Break down products of ferulic acid.

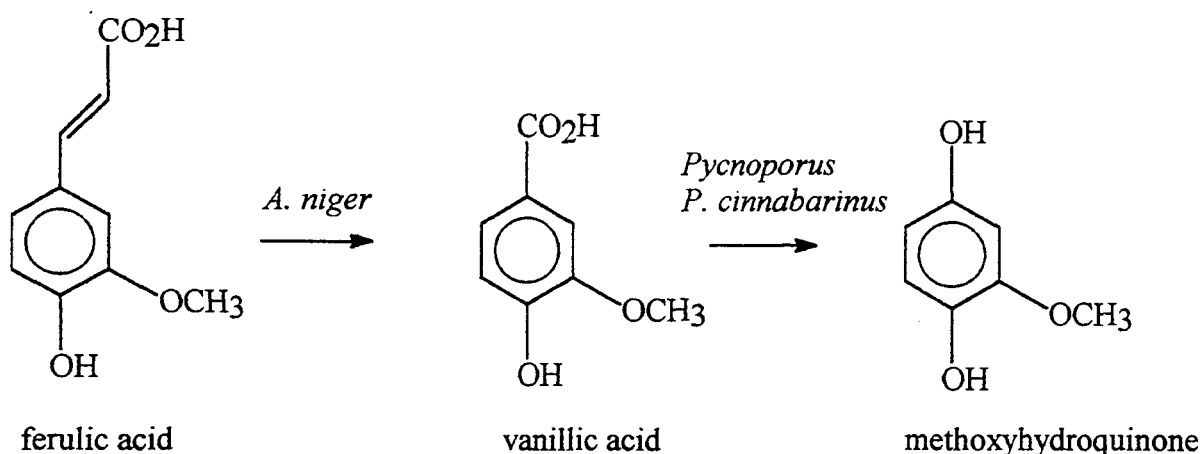

#### 4.3. Synthetic tanning

##### 4.3.1. Synthetic polyphenolic agents

Hydrolysable tannins are a ready source of polyphenols: gallic acid, ellagic acid and chebulic acid, shown in Fig. 8. These might be reconstituted, in a way to control and optimise the molecular weight, through depside esterification: examples are given in Fig. 9.

The alternative is to rethink the structure of phenolic syntans. In Section 2.3 it was clearly demonstrated that, for crosslinking the aromatic nucleus, the most reactive moiety is 1,3-dihydroxy benzene. It is reasonable to suppose that a range of low molecular weight polymers might be made from the appropriate ratios of formaldehyde and phloroglucinol, pyrogallol or resorcinol. The average molecular weight can be predicted from the following table, taken from Thorstensen (50).

Table III. The effect of reactant ratio on polymer size in phenolic coupling.

Molar ratio of formaldehyde to phenol	Average number of phenol molecules per monomer	Average molecular weight of polymer
0.50	2	300 - 350
0.66	3	450 - 500
0.75	4	600 - 700
0.80	5	750 - 900
0.90	10	1500 - 2000
>1.0	theoretically infinite	theoretically infinite

Taken together with the observations made from Table I, it is clear that useful syntans can be made from phloroglucinol, pyrogallol and resorcinol crosslinked with formaldehyde: by keeping the molecular weight below 1000, they should be crosslinkable on collagen, to give high hydrothermal stability tannages.

An alternative approach is to use analogous compounds. Examples might be sulphone compounds, which have been used to elucidate the semi metal reaction mechanism (51), as shown in Table IV and Fig.10. Another option might be to use simpler model polyphenols, other than those referred to above: an example is the tetrahydroxy derivative of naphthalene, shown in Fig. 11, which exhibits the potentially interesting transition to the corresponding naphthaquinone, see Section 4.3.2.

Fig. 8. The components of hydrolysable polyphenolic tannins.

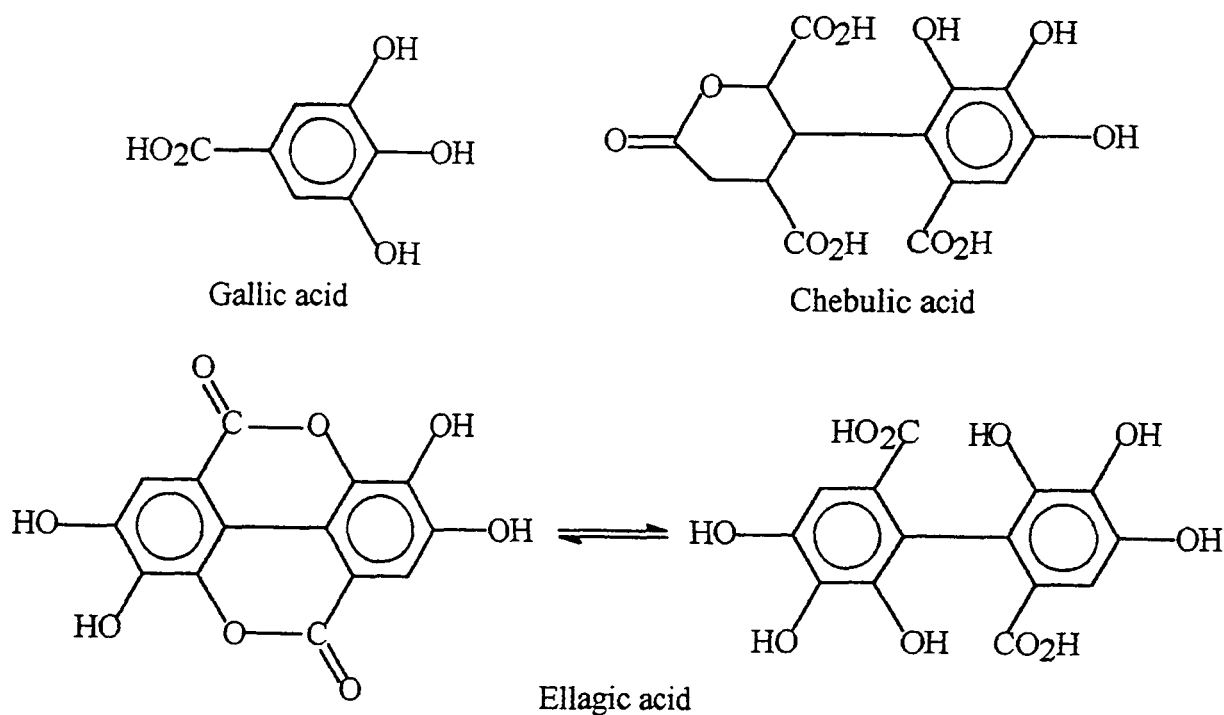

Fig. 9. Ester derivatives of gallic acid.

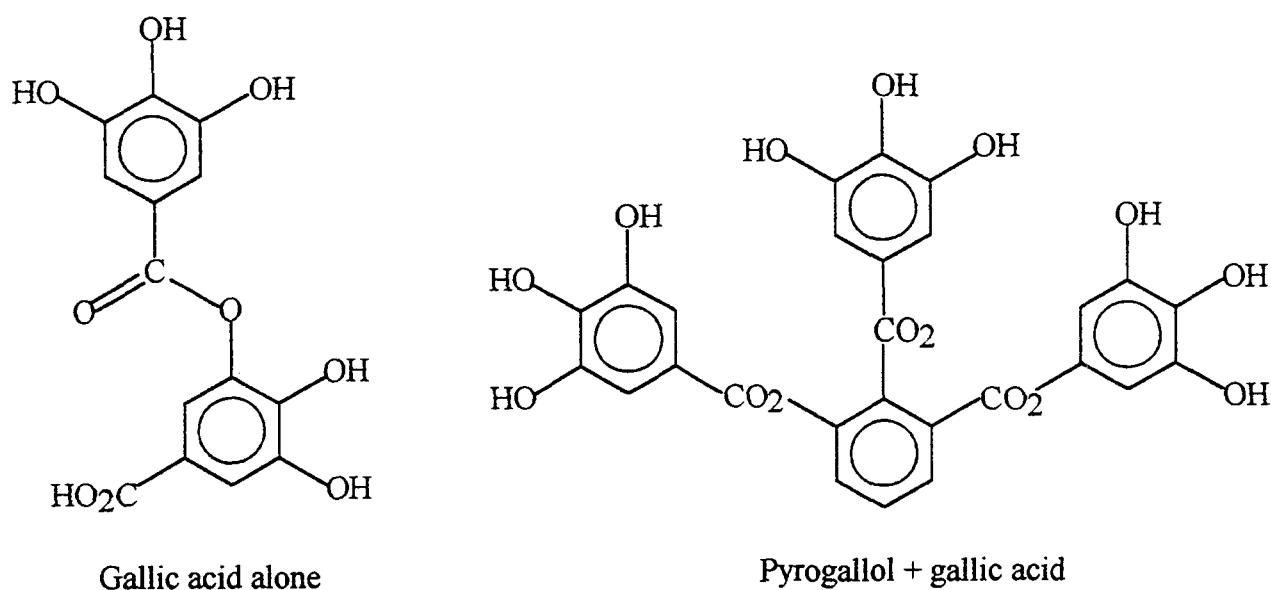

Table IV. The effect of polyphenolic sulphone structure on the shrinkage temperature of model semi alum tannages.

Phenol	Shrinkage temperature (°C)
Catechol, 1,2-dihydroxybenzene	71
Phloroglucinol, 1,3,5-trihydroxybenzene	72
Pyrogallol, 1,2,3-trihydroxybenzene	98
2,3,4,2',3',4'-hexahydroxy diphenyl sulphone*	98
3,4,5,3',4',5'-hexahydroxy diphenyl sulphone*	108

\* see Fig. 10

Fig. 10. Polyphenol sulphones.

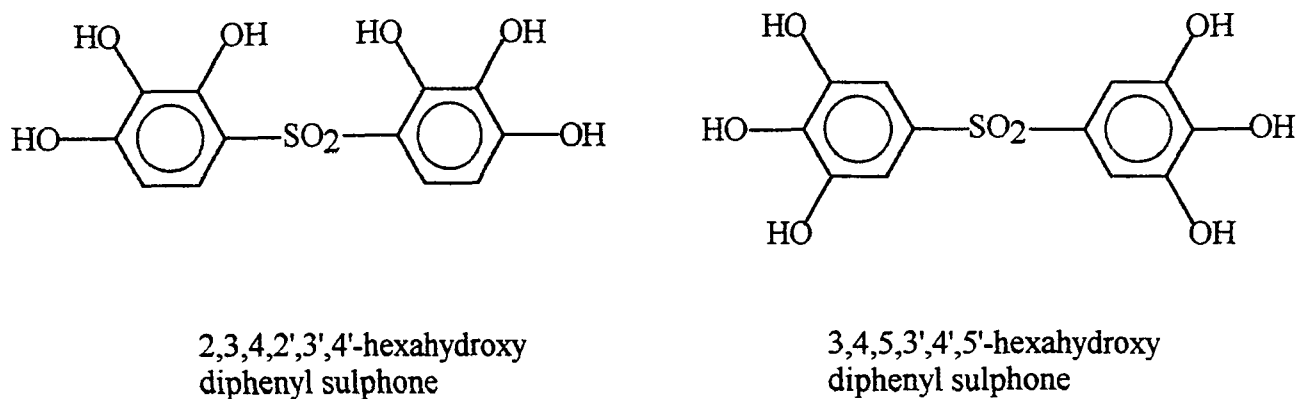
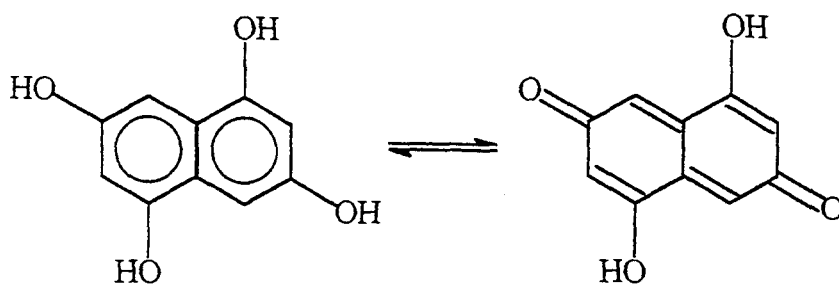

Fig. 11. Structure of a potentially useful tetrahydroxy naphthalene compound.



#### 4.3.2. Synthetic organic agents

It is known that reactions can occur between polyphenols and collagen via quinoid structures, so it is appropriate to examine quinone chemistry. The drawback to the use of the parent compound is its toxicity, but it has been shown to be an effective tanning agent (52). It may prove fruitful to revisit this chemistry, perhaps using simple derivatives to crosslink synthetic oligomeric polymers. Many natural quinoid derivatives are known, but they form the basis of pigments and colouring agents, which would be undesirable in general leather production. Therefore, it is probably more appropriate to utilise the quinoid reactions of polyphenolic compounds.

The successful synthetic tannages to date are two component systems: a primary polymeric tannin and a covalent crosslinker. With regard to the primary tannin, success has been achieved with multiple hydrogen bonded agents, specifically melamine-formaldehyde polymers, Fig. 12a, which are amenable to aldehydic crosslinking. It is useful to consider other options. In the leather field, resin types based on urea, dicyandiamide and urethane are established, both as pure polymers with formaldehyde and as mixed polymers.

Fig. 12. Synthetic polymers.

#### 12a. Melamine-formaldehyde

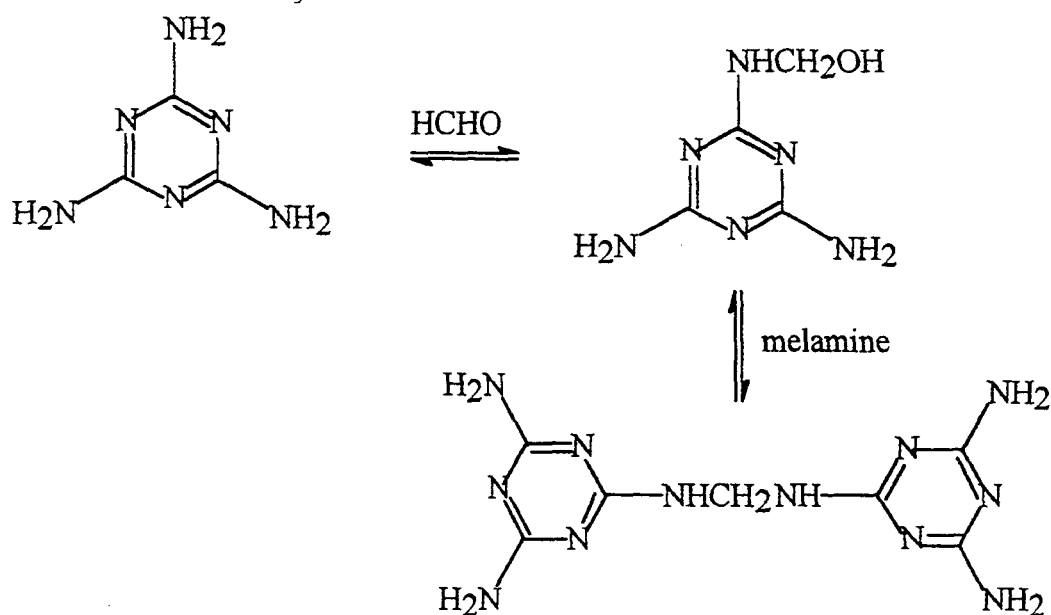

(i). Urea-formaldehyde.

These polymers are effectively simpler versions of melamine-formaldehyde, because the chemistry is exactly the same, see Fig. 12b, although the degree of crosslinking is limited by the availability of reaction sites at which methylol or methylol-type moieties can be formed.

12b. Urea-formaldehyde

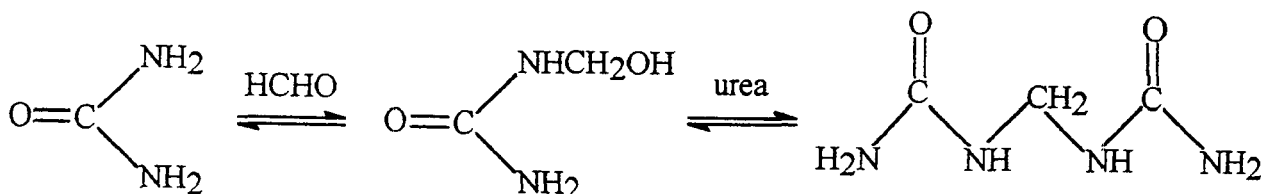

(ii). Dicyandiamide-formaldehyde.

Polymerisation can occur via three different reaction sites, see Fig. 12c, only one of which has similar reactivity to melamine, so it is probable that such polymers will be less reactive in the organic tanning reaction.

12c. Dicyandiamide-formaldehyde

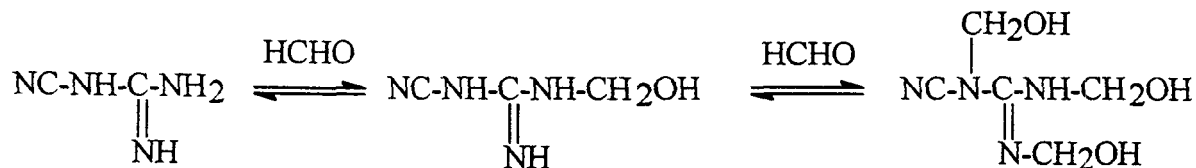

(iii). Polyurethane.

These polymers are amide derivatives, see Fig. 12d, so their reactivity towards aldehydic crosslinkers is much lower than amine derivatives.

12d. Polyurethane



There are two elements of the reactivity of the polymer tannin that must be satisfied: first there must be strong interaction with collagen, which should be by hydrogen bonding, preferably supplemented by covalent reaction, and second the polymer tannins must allow aldehydic crosslinking. There are additional criteria for success. The primary reaction must constitute sufficient interaction, which has not yet been quantified, to constitute additional structure-making, but the size of the species is critical in determining whether or not the subsequent crosslinking confers the required additional structure to produce high hydrothermal stability. This means that the reagent should be astringent, but small.

Developments in this area can be made in combinations and permutations of melamine, urea,



dicyandiamide, probably turned into oligomers with formaldehyde. The choice of crosslinker in this context is determined by the rigidity it can confer to the oligomer: formaldehyde potentially can produce the shortest crosslink. However, the problems of the presence of free formaldehyde, in both the product and the leather, may oblige the industry to use other crosslinking agents; although the situation should be mitigated by using lower amine to formaldehyde ratios to produce lower molecular weight polymers. In any event, the presence of free aldehyde at the end of the tanning process can be eliminated by adding a small amount of reactive flavonoid, such as mimosa tannin.

It may be useful to mix the reactive species, using mixtures of melamine and phenolic compounds, crosslinked to oligomers with formaldehyde. These compounds could be crosslinked in situ on collagen with aldehydic reagents, creating the effective matrix by crosslinking the oligomers via the melamine amino groups or via the phenol aromatic nuclei.

#### 4.3.3. Functional tanning agents

The requirement for structure making is to use discrete small molecules that can react with collagen and then be crosslinked in situ. A class of compounds that fulfill the requirement is dyes. Dyes are not often thought of as tanning agents, but their reactivity is analogous to syntans. Essentially, they are relatively simple structures, although widespread in options, combining aromatic chromophores, often through diazo links, with a multiplicity of auxochromes: it is the latter that confer the reactivity to collagen and consequently offer sites for additional crosslinking. The application of dyes as tanning agents is not confined to a single dye type, it depends only on the availability of reaction sites.

The compounds available to the industry are wide ranging in terms of the chemical types and the structures within the type groups, illustrated in the following sections. The examples presented in this paper are by no means definitive, but serve to offer some indication of the sorts of structures that might be of interest in a tanning context and on which tanning structures could be based.

##### 4.3.3.1. Acid/mordant dyes

This is the largest of the groups, from which most leather dyes are drawn. It could also include premetallised dyes, but these have reactivities dependent upon metal complexation and therefore would be excluded from considerations of organic tanning. However, they may have application in other contexts, see Section 5.2. The reactivity of this class of dyes is dependent upon the presence of sulphonate groups, capable of forming electrostatic bonds with the protonated amino groups of lysine and the partially cationic nitrogen of the peptide link, assisted by the presence of hydrogen bonding from the auxochrome groups. The molecules typically have low molecular weight, in which electron delocalisation is usually dependent upon the presence of at least one diazo link, see Section 4.3.4.7.

Some examples of useful structures are indicated in Fig. 13, in which there are reactive moieties that can be exploited in a tanning context. Note, the difference between acid and mordant dyes is that the former function by themselves, but the latter rely for their effect on additional reaction, typically with a metal salt.

Fig. 13. Examples of reactive acid/mordant dyes.

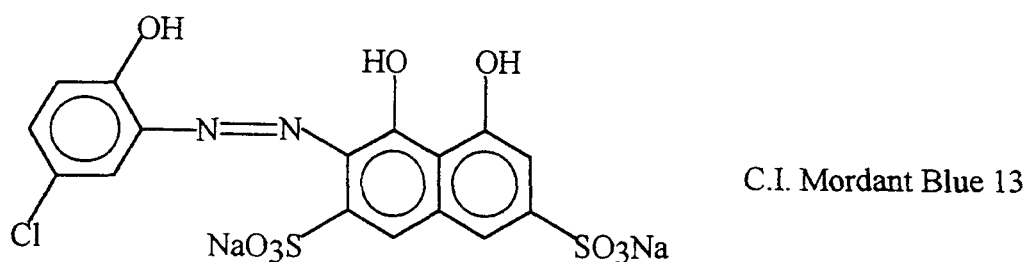
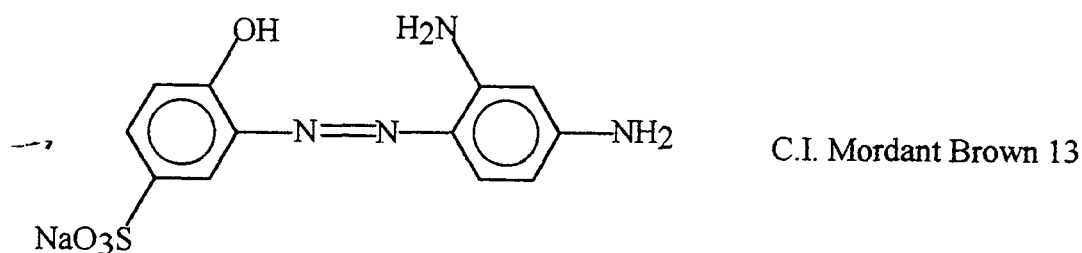

#### 4.3.3.2. Basic dyes.

Basic dyes have similar structures to the acid dyes, but although sulphonate groups may be present, the reactivity is controlled by basic auxochrome groups.

Fig. 14. The structure of a basic dye: C.I. Bismark Brown G

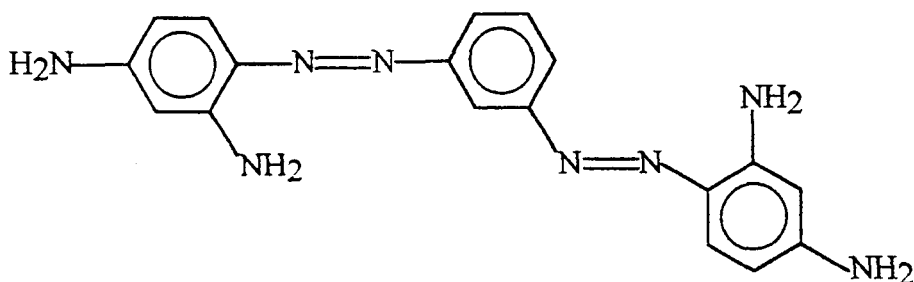

#### 4.3.3.3. Direct dyes.

Direct dyes are so named because of their greater reactivity, because they can react directly with the substrate, without the requirement of fixation by acid. They have higher molecular weight than the usual acid dyes, but the make up of the structures is similar: their surface reactivity may make this class of compounds less attractive as the basis of tanning agents.

Fig. 15. The structure of C.I. Direct Blue 84.

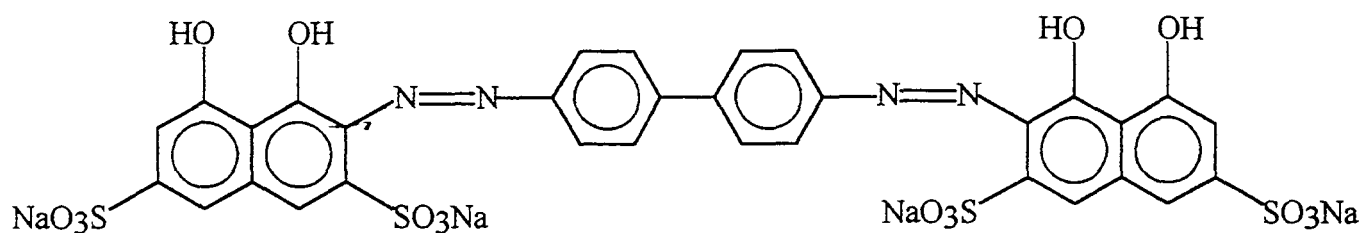

#### 4.3.3.4. Disperse dyes.

The term refers to those dyes whose reactivity can be manipulated by controlling the solubility in the solvent medium. In the light of the new insight into the dependence of processing reactions on the thermodynamics of solvation, see Section 4.1.1.1, this type of chemistry could be a fruitful source of useful new processing reagents.

Fig. 16. The aqueous chemistry of indigo.

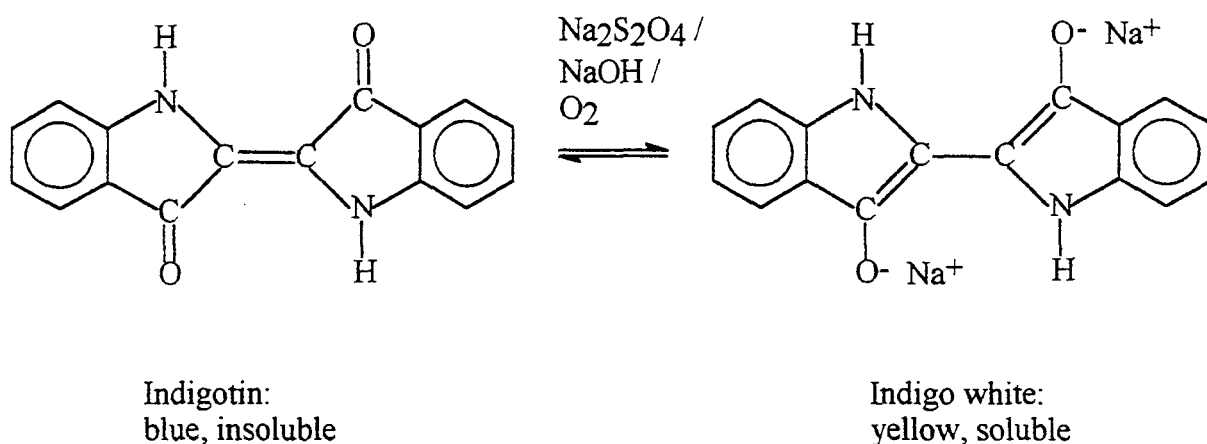

#### 4.3.3.5. Sulphur dyes

Among the dye types, sulphur dyes are a special case, since their structures are usually indeterminate. However, some of the components of the dyes are set out in Fig. 17, indicating the reactive nature of the aromatic moieties, some of which may be capable of being crosslinked like other aromatic polymers.

Fig. 17. Moieties in sulphur dyes.

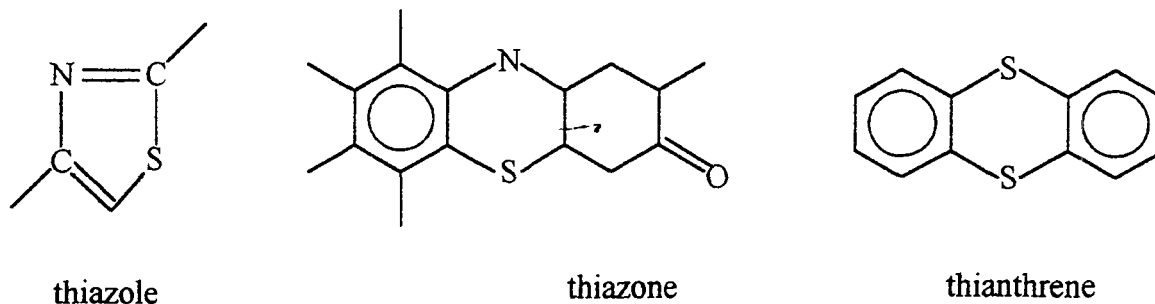

An interesting aspect of sulphur dye chemistry is that the dyes can be split at disulphide bonds by sulphide ion, in a reaction analogous to the attack at cystine in keratin, during conventional hair burning. In the case of sulphur dyeing, the effect is to discharge the colour, by creating the leuco (white) form of the dye. This may be the preferred species for tanning reactions. It should be noted that the colour is reestablished in the sulphur dye by an oxidation reaction, which would have to be inhibited.

#### 4.3.3.6. Other dye types.

The range of dyes available is wide, each with the potential for offering useful tanning chemistries: of the classes not covered by Sections 4.3.3, only one example is presented in Fig. 18, in which the distribution of functional groups is interesting.

Fig. 18. The structure of C.I. Acid Violet 19.

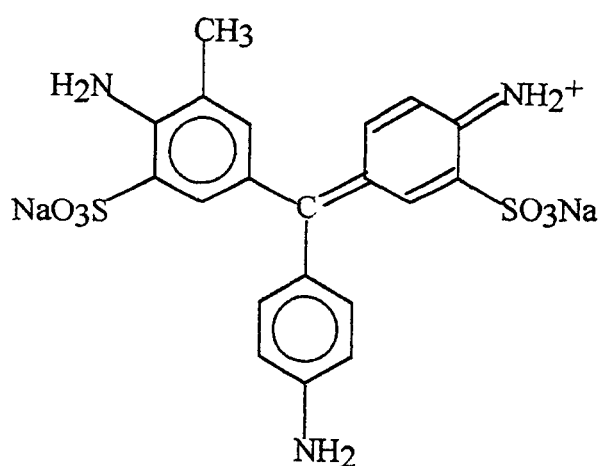

#### 4.3.4. Crosslinkers

The role of the crosslinker in the tanning process reflects the considerations of the polymerisation. At the outset, it should be made clear that attempting to conduct high stability

tannage by simply using multifunctional aldehydic agents is bound to fail. These agents react solely with the amino groups on the amino acid sidechains (53), so the reaction is dominated by lysine. Because the chain either side of the crosslink is four methylene groups long and the crosslinking agent can only increase the length of the crosslink, it can never confer the degree of structure which produces high hydrothermal stability. In addition to that effect is the question of the relative reactivities of the crosslinker, both for itself and for the amino groups: the former typically will result in the crosslinker acting as an oligomer.

It is possible to deactivate the amino groups, either by acylation to amido derivatives or by reaction with nitrous acid to hydroxyls, thereby promoting reaction at the peptide link. However, although the chemistry is feasible, the damage to the collagen structure is severe.

In order to optimise the crosslinking of the primary tannin, it will be necessary to develop additional compounds for this purpose. Options for the future can be classified as follows.

#### 4.3.4.1. Aldehydes

Many aldehydes are commonly available, but typically exhibit lower reactivity than formaldehyde (18). What is needed are aldehydes that have little tendency to polymerise, that have an intramolecular stabilising mechanism, such as is suggested in Fig. 19. An alternative approach might be to utilise compounds starting from less common carbohydrate compounds, to create low molecular weight derivatives.

There are families of dialdehyde compounds that could be developed: for example, from pyrrole, as shown in Fig. 20 (54), where the crosslink would be constrained by the rigidity and stereochemistry of the alicyclic ring.

Fig. 19. Stabilised dialdehyde

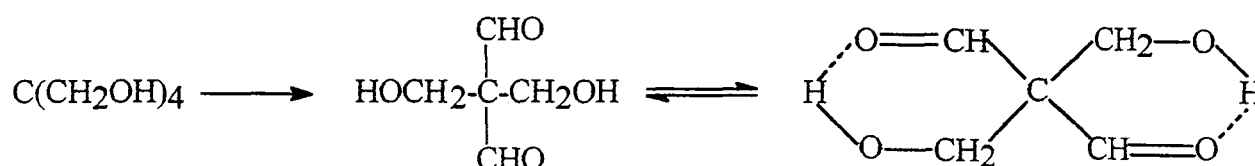
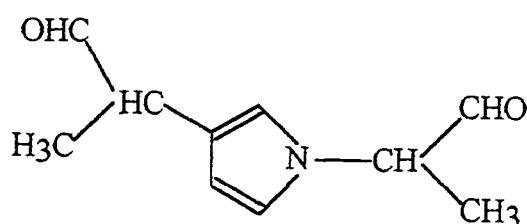

Fig. 20. Pyrrole dialdehyde



#### 4.3.4.2. Aldehydic crosslinkers.

Oxazolidines are examples of aldehydic compounds, since they are derivatives of intermediates in the aldehyde crosslinking reaction mechanism. They can be made from a variety of amino alcohols, cyclised by carbonyl compounds, by the simple reaction of refluxing them together: the general reaction is set out in Figure 21 and examples to illustrate the range of derivatives are presented in Fig. 22. Each of the compounds shown in Fig. 22 is capable of reacting with mimosa tannin on collagen, demonstrated in Table V, in tannages involving 20% mimosa, followed by 10% oxazolidine (55).

Fig. 21. The synthesis of oxazolidines.

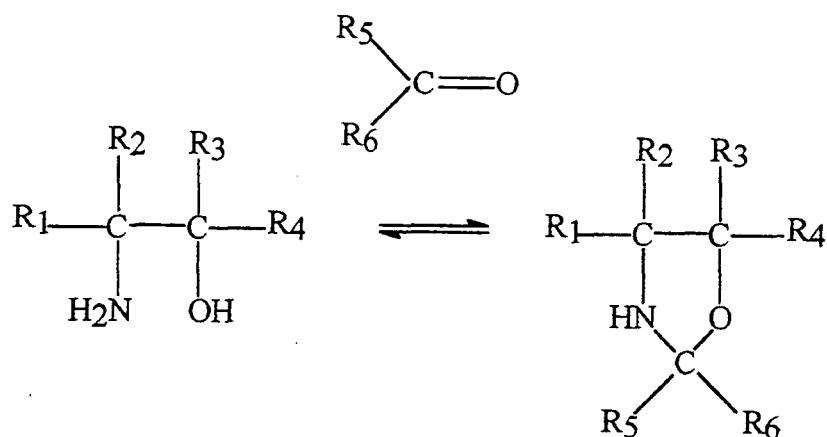

Fig. 22. Oxazolidine derivatives.

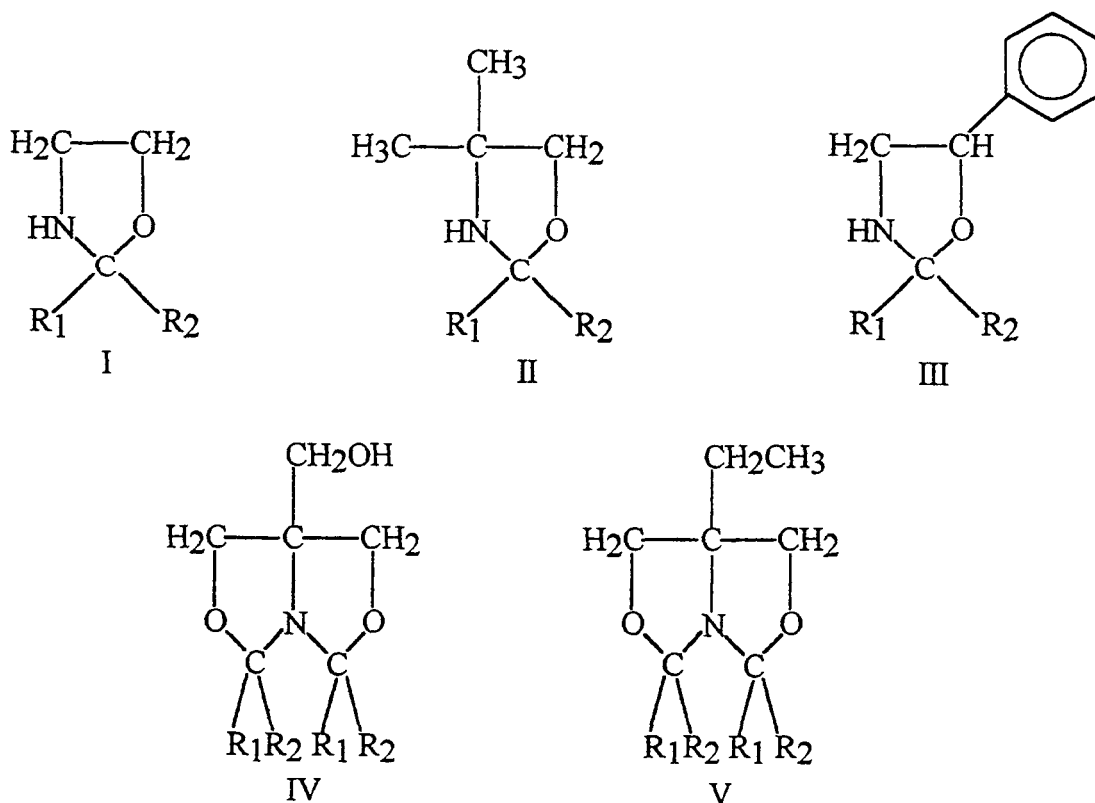

Table V. Shrinkage temperatures<sup>a</sup> of leathers tanned with 20% mimosa and 10% oxazolidine.

Oxazolidine	Formaldehyde crosslinked (R <sub>1</sub> , R <sub>2</sub> = H)	Acetaldehyde crosslinked (R <sub>1</sub> = H, R <sub>2</sub> = CH <sub>3</sub> )	Acetone crosslinked (R <sub>1</sub> , R <sub>2</sub> = CH <sub>3</sub> )
Control: Ts 87°C			
I	102	96	95
II	104	95	92
III	104	98	98
IV	106	101	96
V	103	98	95
Neosyn TX	103		

<sup>a</sup> determined as shrinking onset values by differential scanning calorimetry.

<sup>b</sup> see Figs. 21, 22.

It is noteworthy that there is little difference between the monocyclic and the bicyclic derivatives in their effects on shrinkage temperature. This clearly indicates that the crosslinking mechanism for the monocyclic compounds must involve both the nitrogen and the oxygen of the opened ring. This is in contrast to the results obtained from studying Oxazolidine II (compound V, in Fig. 22), when it was found that crosslinking is dominated by the nitrogens (22).

It is certain that other compounds of this type can be made and some suggestions are presented in Fig. 23.

Fig. 23. Aldehydic compounds

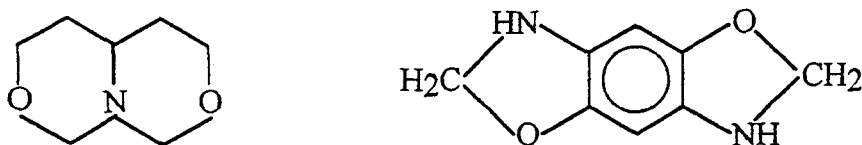

#### 4.3.4.3. Nitromethane derivatives

The aldehydic reaction typically functions through the formation of an active hydroxy species, formed at amino groups, to create the N-methylol derivative, demonstrated in Fig. 12. The reactivity stems from the presence of the nitrogen, with its lone pair, capable of partially donating the electrons towards the hydroxyl and thereby facilitating its ability to leave, which is a requirement in S<sub>n</sub>1 and S<sub>n</sub>2 reaction pathways. The molecular structure is illustrated in Fig. 24, as resonance structures.

Fig. 24. The reactivity of the N-methylol group as a crosslinking moiety.

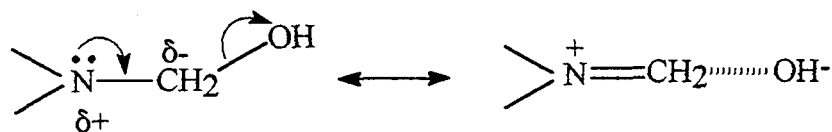

Similarly, any other mechanism that can activate hydroxyl groups in this way will create a crosslinking compound. Happich and Windus (56) showed that the nitro group has the inductive effect of doing this in the compound tris(hydroxymethyl) nitromethane (THNM), shown in Fig. 25.

Fig. 25. The crosslinking activity of tris(hydroxymethyl) nitromethane.

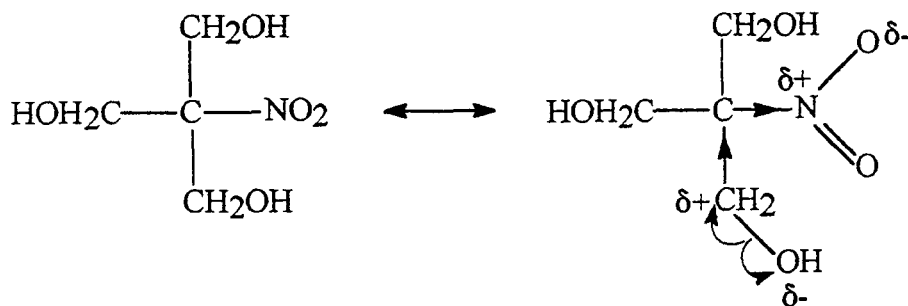

In experiments with resorcinol as the primary reactant, Happich and Windus demonstrated a tanning reaction with THNM, although the highest shrinkage temperature achieved at pH 8.3 and 30°C was only 93°C. It is highly probable that the results would have been improved by adopting Covington's high temperature approach to similar reactions (20, 21).

In comparison, tetrakis(hydroxymethyl) methane (pentaerythritol) was unreactive in these reactions, because the hydroxyls are not activated by the central carbon atom. The principle of hydroxyl activation is clear and other crosslinkers, based on this principle, can be made.

#### 4.3.4.4. Phosphonium compounds.

By analogy with the argument in Section 4.3.4.3., the presence of lone pairs of electron associated with atoms next to the carbon of the methylol group should always activate the hydroxyl group. Just from electronic configuration considerations, that role could be fulfilled by phosphorus, since it is in the same group as nitrogen. The effect has been demonstrated. Phosphonium salts,  $[P(CH_2OH)_4]^+$ , have been shown to be particularly effective crosslinkers for melamine resins: it is reasonable to expect that others will be found for other applications.



Windus reviewed some options, such as tris(hydroxymethyl) phosphine oxide, bis(hydroxymethyl) phosphinic acid, tris(1-aziridinyl) phosphine sulphide or oxide (23): although he found no effect with resorcinol, there is no reason to suppose that they have no crosslinking ability for other reactive systems, using more appropriate conditions that he did not explore.

The argument can be extended to include elements below phosphorus in the periodic table: arsenic, antimony and bismuth. There are arguments against pursuing that line of enquiry:

- a. These elements are toxic.
- b. The hydroxymethyl derivatives would have to be made via the hydrides: arsine, stibine, bismuthine, which are dangerously toxic and increasingly unstable.
- c. The trend towards favouring lower oxidation state with increase in atomic weight, would indicate the diminishing availability of the lone pairs, so there would be a reduced activating affect on the methylol groups.

#### 4.3.4.5. Aromatic nitrogen heterocycles.

The triazinyl chloride moiety (also named cyanuric chloride) has found application in the Procion reactive dyes and other reactions for binding groups covalently to collagen (12). Cater (53) observed that cyanuric chloride itself was more effective than dialdehydes in stabilising collagen. The reactivity is greatest with the first chloro group and progressively less reactive at the other two. This presents the possibility of modifying the crosslinking reactivity, by substituting one of the chlorines and relying on crosslinking by the remaining two reaction sites.

Similarly, reactivity is obtained from other nitrogen heterocycles, as indicated in Fig. 26. Clearly this type of chemistry can be exploited in a tanning context, where the requirement is to balance the rates of reaction with collagen and hydrolysis in solution: this should be controllable by chemical substitution into the aromatic nucleus.

#### 4.3.4.6. Vinyl derivatives.

Taking the example of reactive dyes further, it should be possible to modify the chemistry of other reactive dye systems, which rely for their effect on the presence of a reactive vinyl group, which may be generated in situ. Examples of systems in which the vinyl group is activated by the presence of the sulphone group are shown in Fig. 27. In a dyeing context, there is usually only one reactive centre per molecule, to allow unipoint fixation to the substrate, but clearly these systems could be modified to allow crosslinking at more than one active hydrogen centre on the substrate.

Fig. 26. Examples of reactive dyes based upon aromatic nitrogen heterocycle reactivity.

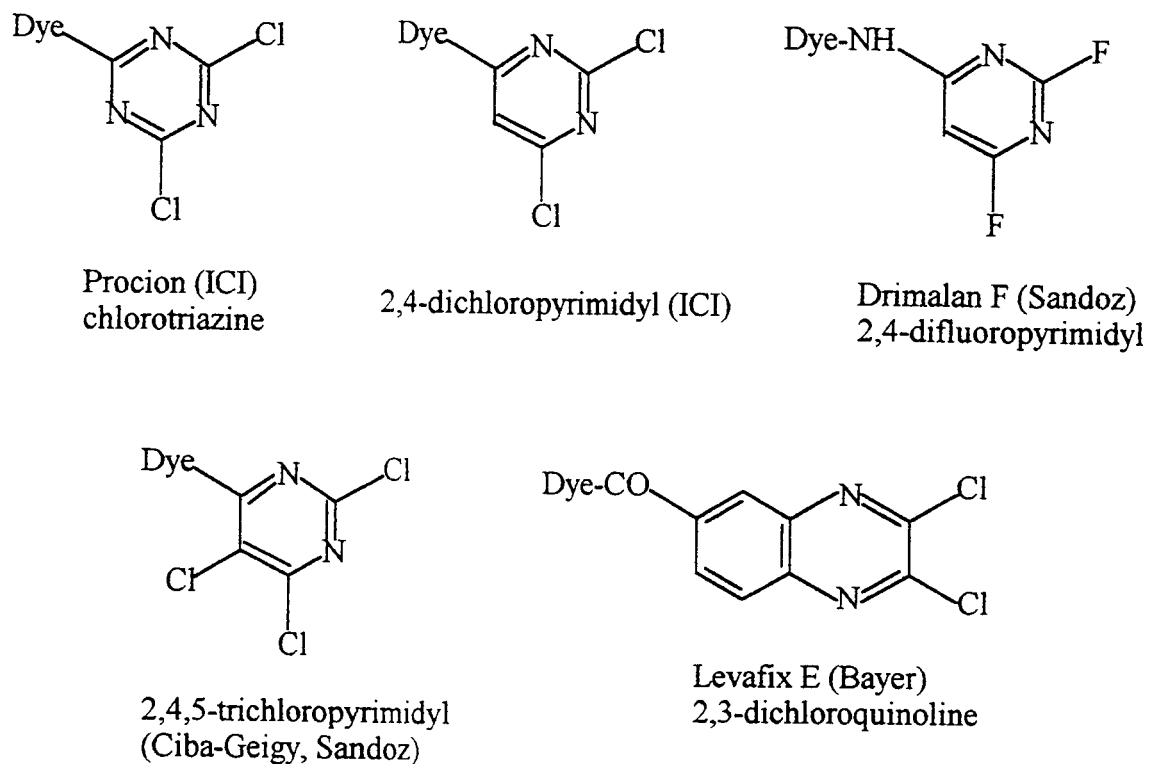
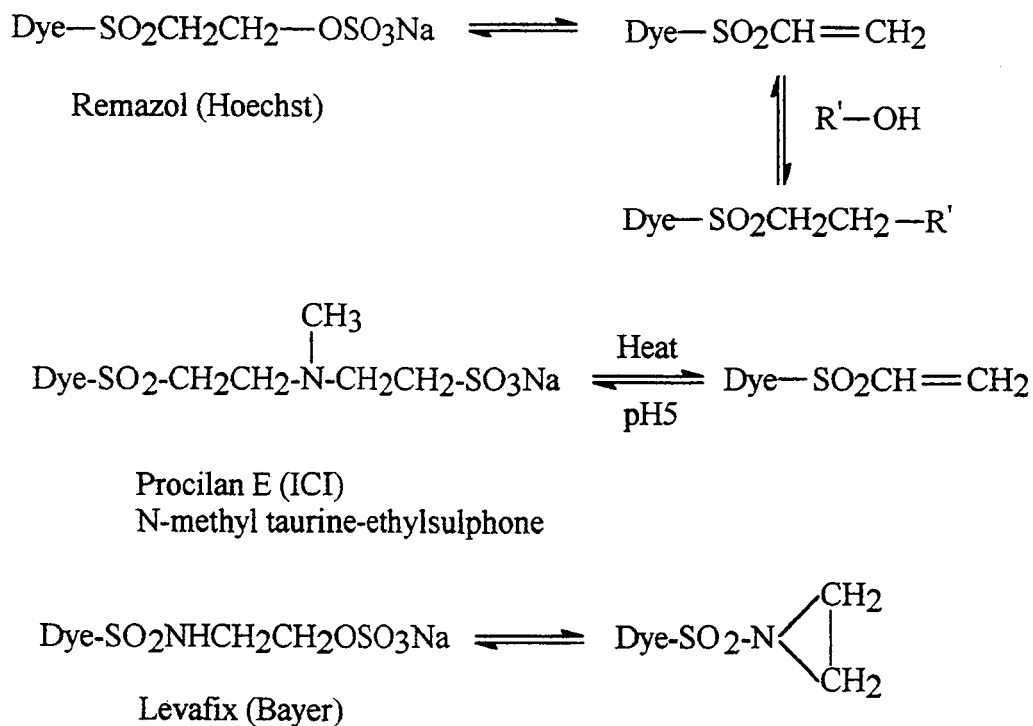
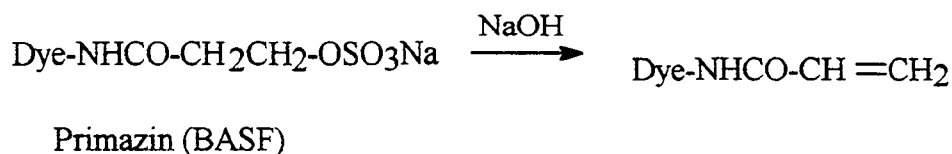
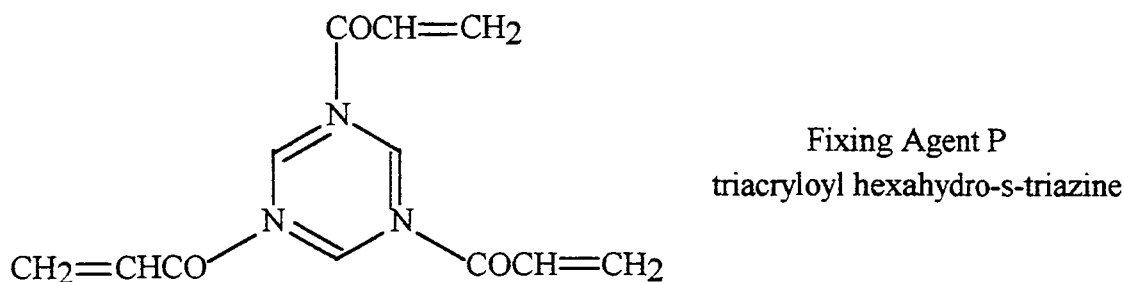

Fig. 27. Covalent reaction based on the vinyl sulphone group.



Another useful feature of the reactivity of the vinyl group is its activation by a carbonyl group, producing the reactivity of the acryloyl group. This has already been exploited in the form of the BASF product Fixing Agent P, used to fix dyes to substrates with active hydrogens, but is also used in types of reactive dyes, shown in Fig. 28. Clearly there is a potential role for compounds of this type in tanning.

Fig. 28. Reactive compounds based on the acryloyl group.



Some advantage might accrue from combining more than one type of crosslinking group into the crosslinking agent, exemplified by the reactive dyes shown in Fig. 29.

Fig. 29. Combinations of reactivities for covalent fixation/crosslinking.

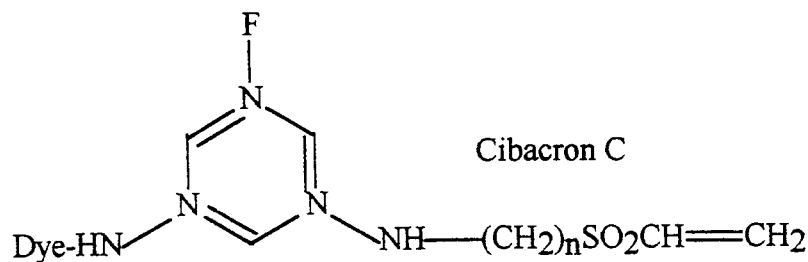
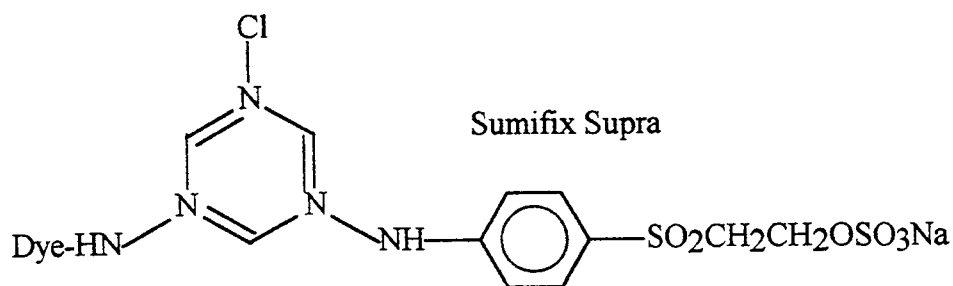

#### 4.3.4.7. Diazo linking

The basis for linking chromophores is primarily via the diazo group: the chemistry is simple, shown in Fig. 30, in which an (aromatic) amino group is converted to the diazonium salt, which can react easily with other aromatic centres.

Fig. 30. Linking by the diazo group.

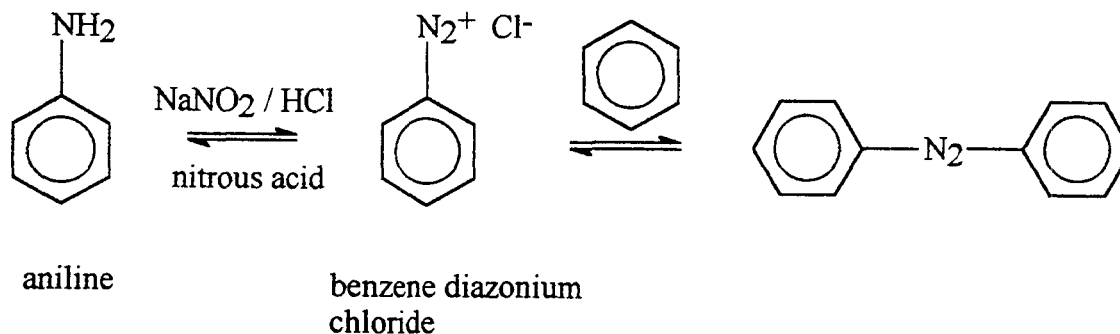

There is a requirement for low temperature in the reaction, since the diazonium salt is readily hydrolysed. It is possible that this reaction might be exploited in tannages where there are free aromatic amino groups available. However, it should be noted that collagen itself has amino groups on its sidechains and these too can be very easily converted to hydroxyl groups by rapid hydrolysis of the unstable aliphatic diazonium salt. That in itself would not appear to cause problems in the chemistry of tanning, but it should be noted that the diazotisation reaction does cause damage to the structure, in the form of swelling by generating nitrogen within the structure and as discolouration.

#### 4.3.4.8. Oxygen heterocycles

The activation of alicyclic and aromatic rings by oxygen provides potential for crosslinking reactions, illustrated in Fig. 31 and other active compounds are presented in Fig. 32.

Fig. 31. Examples of oxygen heterocycle reactivity.

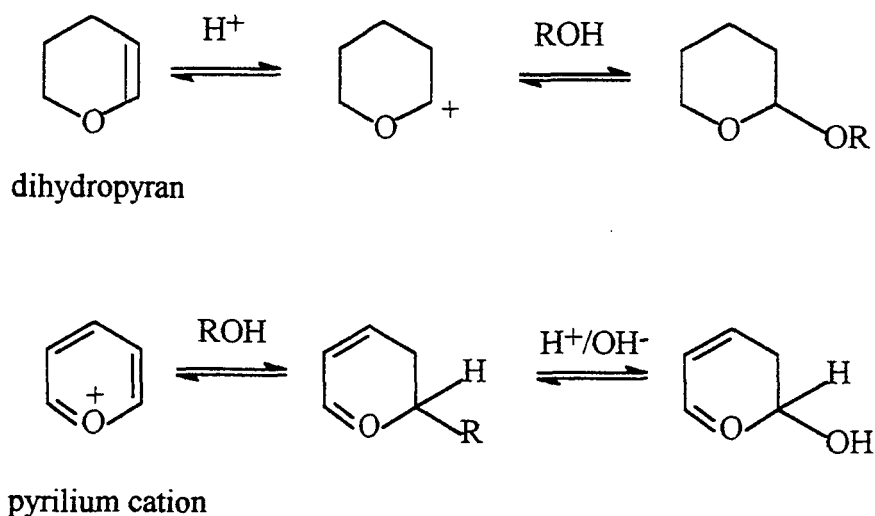
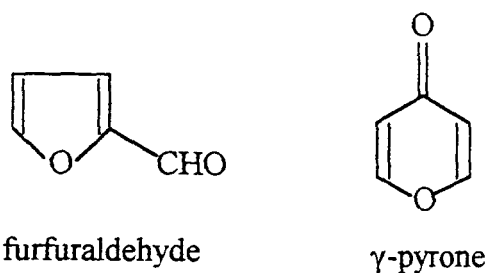

Fig. 32. Active oxygen heterocyclic compounds.



#### 4.3.4.9. Other chemical crosslinkers

There are other covalent crosslinker possibilities, probably more familiar as the basis for polymers, such as those presented in Fig. 12: dimethylol urea, diisocyanates, dicyandiamide. Other crosslinkers are shown in Fig. 33: epoxides and aziridines.

Fig. 34. Structures of crosslinkers, more familiar for applications in non aqueous solvents.

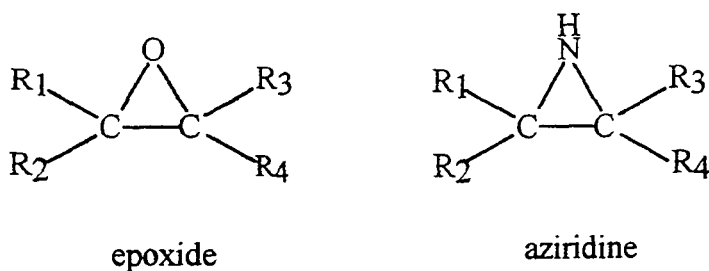

These types of reagent are established in resin chemistry, also established in the leather field as crosslinkers for finishes. Their use is best known in solvent finishing, but now aqueous finishing has been adopted by industry, those crosslinkers developed for non aqueous reactions may find applications in aqueous tanning. In particular, it should be possible to synthesise derivatives that are resistant enough to hydrolysis to be useful in this context, as mentioned in the context of reactive dye systems.

There are two requirements in new crosslinkers: first, they should function efficiently and effectively in the tanning solvent, typically water, second, they should exhibit greater affinity for the substrate than for themselves, so that reaction as monomeric species is thermodynamically preferred to polymerisation, schematically represented as follows.

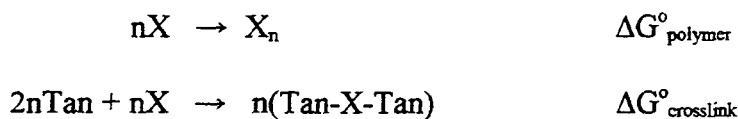

The free energy of crosslinking must be more favourable than the free energy of polymerisation. There is no way of predicting the affinity of the crosslinker for the primary

tannin, it will have to be established experimentally.

#### 4.3.4.10. Biochemical crosslinkers

The notion of using enzymes as crosslinking agents is highly novel. But the wide variety of chemical transformations that they are capable of inducing makes it possible to consider reactions such as polyphenol oxidase in this context. Two examples of chemical transformations by phenol active enzymes are presented in Fig. 34, in which reactive products are formed, capable of reacting with collagen.

Fig. 34. The enzymatic production of reactive aromatic species.

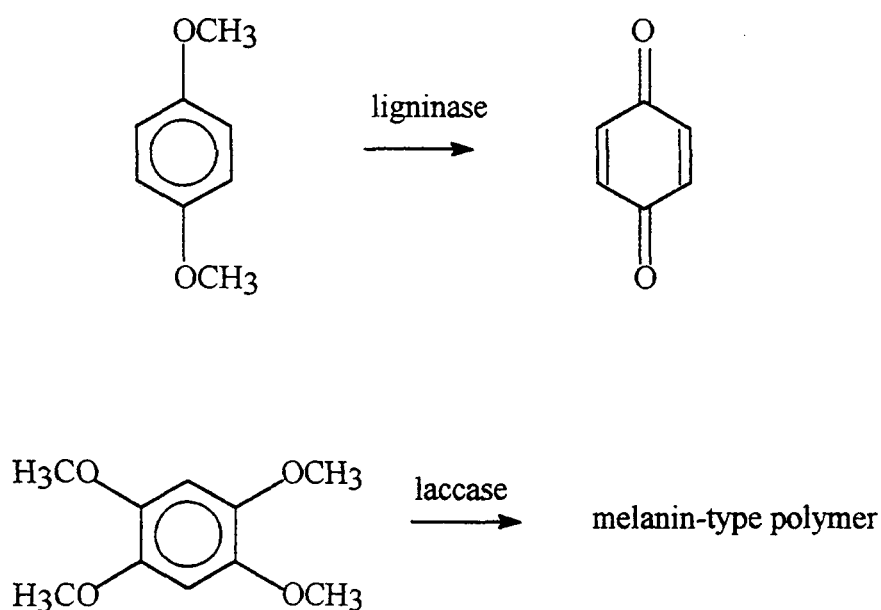

Indeed, it is feasible to consider that some enzymes might be employed to induce useful crosslinking transformations of the collagen structure itself, to induce additional hydrothermal stability. Reaction sites of interest here are aspartic acid, Coll-CH<sub>2</sub>-CO<sub>2</sub>H, and serine, Coll-CH<sub>2</sub>-OH.

Transglutaminase is an enzyme that can create a crosslink between the sidechains of glutamic acid and lysine. It is not known whether the nature of the crosslink, with regard to the length and rigidity, and the number of crosslinkable sites constitute enough imposed structure to produce a useful elevation of hydrothermal stability.

## 5. Future processing development.

### 5.1. Process prediction.

A fundamental and controlling parameter in the leather making process is the isoelectric point: this is defined as the pH at which the collagen or leather has zero net charge. The relationship between iep and pH determines the charge on the substrate and this, in turn, determines the interaction between the substrate and charged reagents. The iep can be defined as follows:

$$\text{iep} = \frac{\sum f_i [\text{NH}_2]_i}{\sum f_j [\text{CO}_2\text{H}]_j} \approx \frac{[\text{NH}_2]_{\text{total}}}{[\text{CO}_2\text{H}]_{\text{total}}} \quad \text{eqn. 3}$$

where:  $f$  is a function of concentration and  $\text{pK}_a$  of each species contributing to the total quantities of acid and basic groups.

The function applied to each species will include a contribution from the equilibrium thermodynamics, to account for the partial nature of any hydrogen bonding or electrostatic interaction, resulting in only a proportion of the base or acid function being removed from the calculation of iep. In order to calculate the charge from the iep, it is necessary to know how processing and process reagents affect the iep, in terms of total or partial effects on either component of the ratio in equation 2. This should be possible, by direct measurement of the thermodynamics of model reactions and the application of fuzzy logic (57). The outcome would be the ability to predict the result of a chemical process, in terms of affinity effects (uptake efficiency, penetration rate) and the effect on subsequent processing. This is because almost all processes are not only affected by the iep, but also have some implications for the iep, and hence each process will influence subsequent process steps.

### 5.2. Combination processing.

There has been a recent trend towards combining process steps: obvious examples are the binding of dyes to vegetable tanning agents (Forestal Quebracho), to achieve retanning and dyeing in one step, and the use of partially esterified acrylate resins (Rohm and Haas), to provide retanning and fatliquoring and even water resistance treatment in one step. It is likely that this trend will continue, in order to simplify the post tanning procedures.

It is possible to predict other combinations of reactions:

- retanning resins modified by reactive dyes,
- fatty acid esterified polyphenols, partially sulphated/sulphonated
- fatty acid derivatives of dyes, as fatliquors or as reactive dyes.

In the limit, it is feasible to envisage a single reagent post tanning process, achieved by a single multifunctional polymer, which might be crosslinked to the collagen structure. In this way, fastness of all post tanning materials can be optimised.

### 5.3. Single step processing.

The problem with the approach set out in Section 5.2 is that the choice of processing options is entirely in the hands of the supply houses; there would be limited choice, compared to the wide range of variations in reagent combinations presently used in the industry as a whole. An alternative approach would be to simplify post tanning, even to include prime tanning, by having a single step process.

The drawback to rapid processes, introduced to provide a Just in Time service to customers, such as dyeing of blue crust, is that the substrate has to be extremely hydrophilic to absorb the aqueous dye solution. An obvious solution would be to use alternative solvent, such as super critical carbon dioxide, see Section 4.1.2. In this way, the leather could be hydrophobic and the dyeing step might be combined with additional lubrication and even retanning agents. It is not a great leap in logic to imagine combining those reagents with retanning materials. Indeed, if neutral hide in the delimed condition could be successfully crusted or alternatively freeze dried economically, the whole process of chrome or organic tanning and post tanning might be accomplished in a single step.

### 5.4. Physical processing.

The processes by which raw collagen is turned into saleable leather are chemical in nature, because chemicals are applied and reacted with the collagen, according to their ground state affinities. Another approach to inducing useful changes to collagen and to chemicals in situ is by free radical reaction. Such species can be obtained by breaking up unstable compounds and thereby creating fragments with at least one unpaired electron: the disadvantage is that a lot of free radical generator would be required to be useful. However, the production of single and diradicals might be more efficient by using flash photolysis (58). The reactions achieved depend on the energy and duration of the radiation exposure. It is possible that some useful reactions could be obtained in this way: it could be considered to be the logical extension of the more familiar UV curing for finishes.

Directly influencing the thermal stability and mechanical integrity of collagen by applying radiation has been investigated using electron beams and gamma radiation (59). However, the effects are more damaging than useful, in this context.

### 5.5. Collagen modification

Collagen modification is typically damaging, when chemical changes are induced. Even the hydrolysis of amido sidechains is accompanied by substantial (but acceptable) damage to the collagen structure. Therefore, it is unlikely that the types of chemistry that could alter the sidechains would find application in industry. Therefore, desired chemical reactions have to be sought in biochemistry. There is a 'shopping list' of reactions that can be predicted to be useful: these all centre on creating reaction sites as acid or basic groups, but on short sidechains, illustrated in Fig. 35.



Fig. 35. Desirable collagen sidechain conversions.

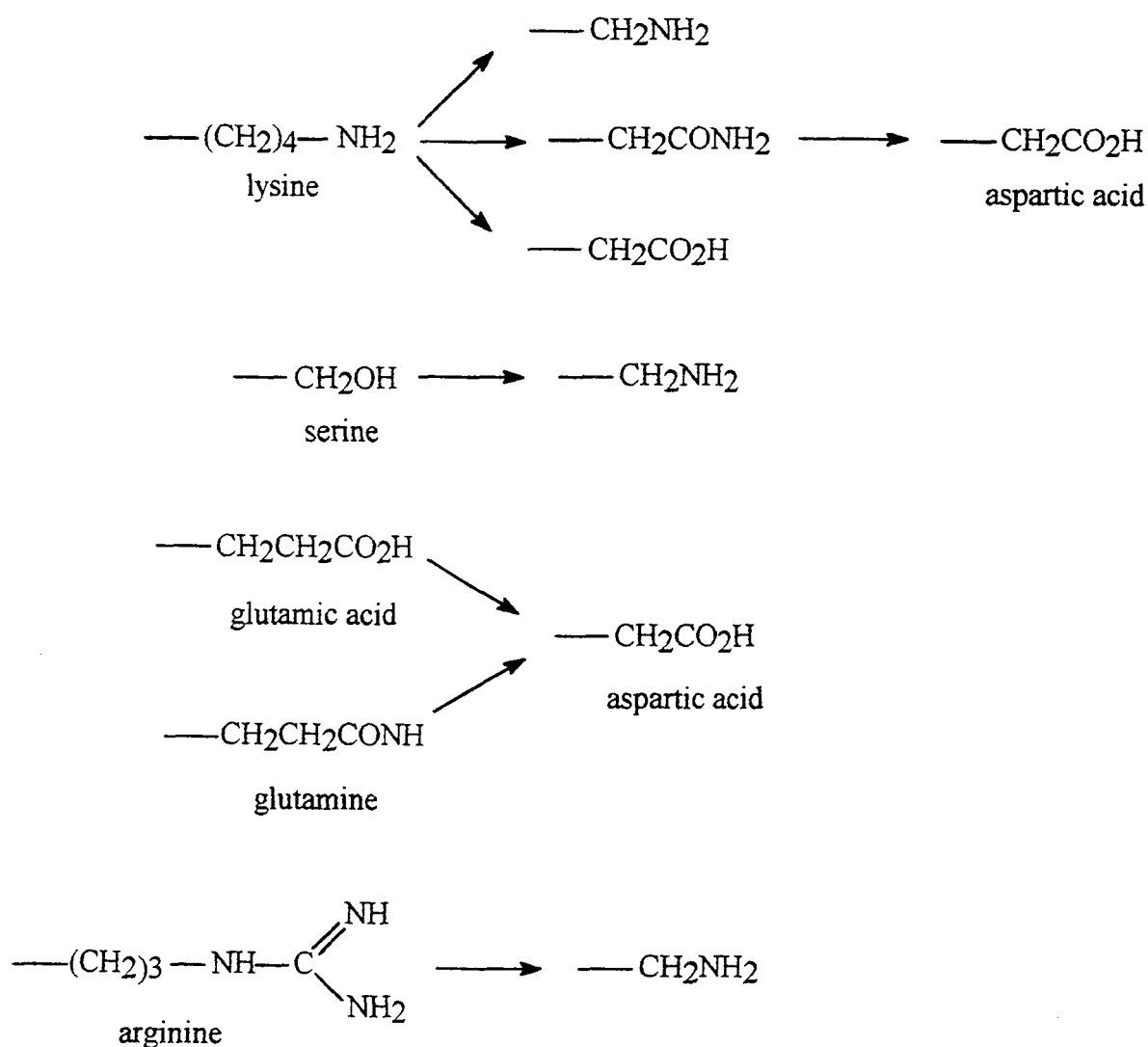

### 5.6. Unstable tannages

The known range of tanning chemistries has the property of exhibiting a range of chemical stabilities, which are not necessarily related to the shrinkage temperatures conferred by the tannages: some examples are given in Table VI.

Table. VI. Indicative stabilities of some tannages.

Tanning	Shrinkage temperature	Chemical stability
Chromium(III)	high	high
Aldehyde	medium	very high
Polyphenol	medium	low
Metal salt	low	very low

Despite these differences in the effects of the tanning processes, they all have one property in common: resistance to microbiological attack, although differences in that regard have not been qualified or quantified. If tanned leather is to have vulnerability to enzyme degradation, which is the prerequisite for decomposition in the earth, then the principle cannot be based upon the nature and reversibility of the tanning reaction.

The only recourse is to include the possibility of breaking down the crosslink itself. The obvious candidates are the tannages based on carbohydrate aldehydes, where the carbohydrate is more vulnerable to attack than the collagen itself. However, the technology must be investigated practically, since it is not certain that even this approach will work. That suggestion is made on the basis that there are known tannages that function solely by unipoint fixation, ie there is no crosslinking, exemplified by sulphonyl chloride derivative tanning for a synthetic version of oil tanning. This is a leathering reaction, that does not elevate the shrinkage temperature of collagen, but still confers the fundamental property of stabilisation against microbial attack.

The alternative approach is to investigate the limits of leather stability towards degrading enzymes, based on the degree of intactness of the collagen. This is a property that depends on the extent to which the beamhouse processing has damaged the fibre structure. In addition, the fibre structure can be easily damaged by hydrogen bond breakers, such as urea, but it may not be necessary to invoke complete denaturation before the leather becomes vulnerable enough for enzyme induced decomposition to set in. This would be a way in which the protein content could be made vulnerable to damage. However, the tanning compounds would remain intact, unless a decomposition mechanism for them is included in the overall process. Therefore, the tannage itself would have to be organic, but biodegradable, which is not the case for polyphenol or polymer resin based tannins.

The conclusion must be that, if a solution cannot be found within conventional tanning systems, it may be necessary to include in the leather a mechanism by which the structure is damaged by some activating reaction. For example, this might be achieved by including a species that can produce free radicals inside the collagen fibre structure, in the way some plastics can be made rapidly biodegradable.

## **6. Overview**

It can be assumed that there will always be a future for chrome tanning: it is equally certain that operating the chrome tanning process will become harder, with regard to meeting environmental legislation requirements. Therefore, it is necessary to maintain a programme of research and development in this field, in order to offer the industry improved methods of processing. It is clear that the reaction must be approached in a new way, taking into account all the thermodynamic parameters that impact on the uptake and effectiveness of the outcome. By understanding the reaction in a fundamental way, it should be possible to control it more effectively, in terms of both the uptake efficiency and the crosslinking element of fixation.

The most recent studies of the chrome tanning reaction, using synchrotron X-ray radiation for extended X-ray absorption fine structure (EXAFS) examination have shown that the bound

chrome is dominated by linear  $\text{Cr}_4$  species (60). It may be a feature of the specific efficacy of chromium(III) that it forms linear ions, rather than three dimensional species. An important consequence of this particular programme of study is that it has been demonstrated that useful results can be obtained by applying the most modern, high-tech. analytical methods to the study of mineral tanning. For example, these studies have highlighted the basification reaction as being crucial to chrome tanning efficiency, because of the variations in species that can be produced. This is a problem that can be addressed by exploiting the latest techniques in magnetic resonance (60).

At the same time, it is prudent to seek alternative tannages, which must necessarily be organic in nature. Whilst there is still some benefit in considering advances in conventional semi metal processing, there is a limit as to how far this technology can go. The main area for development is pure organic tanning. Recent advances have opened up this subject, previously thought to be effectively a closed field of study. However, it has been demonstrated that high hydrothermal stability is achievable by many chemical systems, as long as they adhere to the required rules of stable matrix formation.

It is less clear that a real alternative to chromium(III) will be developed: organic tanning operates in a different way, using different chemistries and may result in a different mechanism of raising the hydrothermal stability, with regard to the involvement of the supramolecular solvent, although the formation of matrices means that the mechanism of stabilisation is fundamentally the same. However, even the difference in molar offers will result in a reduction in versatility when organic agents are used. Nevertheless, properties like fullness can be minimised, handle can be modified in post tanning, hydrophilicity can be overcome. The important thing is that new leathers should be capable of being used in applications that have hitherto only been satisfied by chrome.

From the observations made in the review set out here, it is not difficult to predict the most likely directions for new, high stability organic tannages:

- a. natural polyphenol derivatives, with reagent-like specificity, crosslinkable in situ with oxazolidine type reagents.
- b. synthetic polymers based on melamine and phenols, crosslinked with formaldehyde or other simple compounds, to produce specified low molecular weight resins, crosslinkable in situ with phosphonium salt or other aldehydic compounds.

It is clear from the most recent developments in tanning theory that tannages which rely for their effect on reaction with the basic groups of collagen are unlikely to form the basis for future tanning chemistries, unless those basic groups can be made available on shorter sidechains. The future lies in chemistries that involve reaction and interaction with the collagen backbone or can exploit the involvement of the solvating species.

The overall conclusion from this brief review and analysis is that leather science has not reached an impasse through lack of support (61) or that the subject is complete. On the contrary, it is about to have a new lease of life, based on fundamental principles, developed by fundamental research.

## References

1. H. P. Chakravorty and H. E. Nursten, *J. Soc. Leather Trades Chem.*, 42(1), 2, 1958.
2. A. D. Covington, *Chem. Soc. Rev.*, 26(2), 111, 1997.
3. A. D. Covington, G. S. Lampard and P. O'Brien, unpublished results.
4. A. D. Covington, *J. Soc. Leather Technol. Chem.*, 70(2), 33, 1986.
5. K. H. Gustavson, *J. Amer. Leather Chem. Assoc.*, 48(9), 559, 1953.
6. A. D. Covington, *Chrome Management*, UNIDO Workshop, Ljubljana, Slovenia, June 1995.
7. A. D. Covington, *Proc. IULTCS Congress*, Chennai, India, January 1999.
8. E. Haslam, *J. Soc. Leather Technol. Chem.*, 81(2), 45, 1997.
9. G. Reich, *Das Leder*, 47(7/8), 157, 1996.
10. E. Heidemann et al., *Das Leder*, 41(1), 8, 1990.
11. C. Gaidau, F. Platon and N. Badea, *J. Soc. Leather Technol. Chem.*, 82 (4), 143, 1998.
12. J. M. Holmes, *J. Soc. Leather Technol. Chem.*, 80(5), 113, 1996.
13. J. H. Bowes and R. G. Elliott, *J. Amer. Leather Chem. Assoc.*, 57(8), 374, 1962.
14. S. H. Fearheller et al., *J. Amer. Leather Chem. Assoc.*, 83(11), 363, 1988.
15. K. Fuchs et al., *AQEIC Boll. Tec.*, 37(6), 195, 1986.
16. S. Das Gupta, *J. Soc. Leather Technol. Chem.*, 63(4), 69, 1979.
17. W. Prentiss et al., *J. Amer. Leather Chem. Assoc.*, 77(2), 84, 1982.
18. A. Pizzi et al., *J. Polymer Sci. Polymer Chem. Ed.*, 18, 3323, 1980.
19. S. Das Gupta, *J. Soc. Leather Technol. Chem.*, 61(5), 97, 1977.
20. A. D. Covington and S. Ma, UK Patent 2,287,953, June 1996.
21. A. D. Covington and B. Shi, *J. Soc. Leather Technol. Chem.*, 82(2), 64, 1998.
22. A. D. Covington and B. Shi et al., *J. Soc. Leather Technol. Chem.*, 83(1), 8, 1999.
23. W. Windus, *J. Amer. Leather Chem. Assoc.*, 47(2), 87, 1952.
24. W. Windus and W. F. Happich, *J. Amer. Leather Chem. Assoc.*, 58(11), 638, 1963.
25. W. Windus and M. V. Hannigan, *J. Amer. Leather Chem. Assoc.*, 60(10), 581, 1965.
26. W. Windus, *J. Amer. Leather Chem. Assoc.*, 48(8), 513, 1953.
27. A. D. Covington and S. Ma., *Proc. IULTCS Congress*, London, September 1997.
28. A. D. Covington et al., *J. Amer. Leather Chem. Assoc.*, 93(4), 107, 1998.
29. A. D. Covington. *Atkin Memorial Lecture*, SLTC Annual Conference, September 2000, *J. Soc. Leather Technol. Chem.*, in press.
30. A. K. Covington, K. E. Newman and T. H. Lilley, *J. Chem. Soc.*, *Faraday Trans. I*, 69, 973, 1973.
31. H. C. Holland, *J. Int. Soc. Leather Trades Chem.*, 24(5), 152, 1940.
32. F. Chiardelli, N. Costantini and A. D. Covington, *J. Amer. Leather Chem. Assoc.*, in press.
33. A. Zaliauskiene, PhD thesis, Kaunas University of Technology, Lithuania, 1999.
34. A. D. Covington, *J. Amer. Leather Chem. Assoc.*, 93(6), 168, 1998.
35. M. J. Collins, A. D. Covington, O. Menderes and E. Waite, *J. Soc. Leather Technol. Chem.*, 83(2), 107, 1999.
36. M. J. Collins, A. D. Covington and O. Menderes, *J. Soc. Leather Technol. Chem.*, unpublished results.
37. F. Sylvestre, C. Rocrelle and A. Gaset, *J. Soc. Leather Technol. Chem.*, 78(1), 1, 1994.
38. B. Vulliermet, *Proc. IULTCS Congress*, Friedrichshaven, Germany, May 1995.
39. R. E. Hamm et al., *J. Amer. Chem. Soc.*, 80, 4469, 1958.

40. L. F. Larkworthy, K. B. Nolan and P. O'Brien, in *Comprehensive Coordination Chemistry*, Pergamon Press, 1987.
41. K. H. Gustavson, *J. Amer. Leather Chem. Assoc.*, 50(12), 445, 1966.
42. R. W. Hemingway and J. J. Karchesy (eds.), *Chemistry and significance of condensed tannins*, Plenum Press, New York, 1989.
43. R. W. Hemingway, A. H. Conner and S. J. Branham (eds.), *Adhesives from renewable resources*. ACS, Symposium Series no. 358, Washington DC, 1989.
44. E. M. Filachione et al., *J. Amer. Leather Chem. Assoc.*, 53(2), 77, 1958.
45. R. Sugiyama, Y. Chonan and H. Okamura, *Hikaku Kagaku*, 43(1), 55, 1997.
46. M. Komanovsky, *J. Amer. Leather Chem. Assoc.*, 84(12), 369, 1989.
47. T. J. Painter, *Bog Bodies*, British Museum Press, 1955.
48. T. J. Painter, *Carbohydrate Polymers*, 15, 123, 1991.
49. C. Faulds, B. Clarke and G. Williamson, *Chemistry in Britain*, 36(5), 48, 2000.
50. T. C. Thorstensen, *Practical Leather Technology*, Krieger Publishing Co., Florida, 4th ed. 1993.
51. R. L. Sykes, R. A. Hancock and S. T. Orzulik, *J. Soc. Leather Tech. Chem.*, 64(2), 32, 1980.
52. H. C. Stecker and J. H. Highberger, *J. Amer. Leather Chem. Assoc.*, 36(5), 226, 1942.
53. C. W. Cater, *J. Soc. Leather Trades Chem.*, 49(12), 455, 1965.
54. R. Lazzaroni, University of Pisa, personal communication.
55. K. Riaz, MSc thesis, University College Northampton, August 1997.
56. M. L. Happich and W. Windus, *J. Amer. Leather Chem. Assoc.*, 65(3), 135, 1970.
57. A. D. Covington and P. Picton, unpublished results.
58. C. Westrup, *Reactive Molecules*, John Wiley and Sons, 1984.
59. A. J. Bailey, D. N. Rhodes and C. W. Cater, *Radiation Research*, 22(4), 606, 1964.
60. A. D. Covington et al., unpublished results.
61. M. H. Mayer, *J. Soc. Leather Technol. Chem.*, 79(1), 1, 1995.

# **The processing of rawstock to leather in the tannery of the future.**

**David G. Bailey**  
**Hides, Lipids and Wool Research Unit**  
**Agricultural Research Service, U. S. Department of Agriculture**  
**600 E. Mermaid Lane**  
**Wyndmoor, PA 19038**  
**USA**

## **Abstract**

The bovine animal hide is a valuable resource that is still used very inefficiently. As little as forty percent of the hide is used for grain leather manufacture and a large fraction of the remaining hide substance ends up in land fill or effluent waste treatment plants. The future process technologies of the tanning industry will be strongly impacted by changes in the meat packing industry that will fully recover the potential of this valuable raw material. Further process improvements will come from advances in microprocessors, that will make it possible to maintain the identification and history of an animal from birth to slaughter and even permit fine process control in the tannery from soaking through finishing. For this element of the presentation the assumption is that the dominant tanning agent fifty years from now will be chromium but the predicted changes will occur regardless of the future tanning agent of choice.

<b>Contents</b>	<b>Page</b>
Abstract	77
Contents	78
1. Introduction	79
1.1. The value of the hide	79
1.2. The bovine meat packing paradigm shift	79
1.3. The tanners industry paradigm shift	80
2. Mechanical changes in hide processing	81
2.1. Fleshing to scanning to splitting to shaving	81
2.2. Benefits to the tanner	81
3. Process evolution	82
3.1. Micro processors	82
3.2. Process controls	82
3.3. Fatliquor, colour, retan	83
3.4. Drying	84
3.5. Finishing	84
3.6. Tannery – general	84
4. Conclusions	85
Acknowledgement	85

## 1. Introduction

### 1.1. The value of the hide

A bovine hide consists of two layers, the grain layer and the corium. The corium consists almost entirely of the protein collagen. The grain layer contains some collagen but many other proteins as well. The grain layer along with a portion of the corium is the traditional starting material for leather. The grain layer contributes the aesthetic value to leather and the corium contributes the strength, flexibility and comfort values. The grain leather raw material accounts for only about forty percent of the hide.

Depending on how the hide is processed to manufacture grain leather, the remainder of the corium layer can end up in a variety of end uses. Most of these are of lower value than the grain leather. These uses include split leather, collagen casings, collagen based medical products, cosmetics, dog chew bones and reconstituted leather board products. The high value end uses, such as medical products and cosmetics, consume only a small fraction of the available collagen. What has not really been exploited is the high value food potential for the corium or collagen layer. While a portion of lime splits from leather manufacture ends up in casings for sausage and hot dogs, this too is only a fraction of the total available. And every year a large amount of the corium ends up in landfills as chrome shavings.

Research performed jointly by Oklahoma State University and the USDA investigated food uses of collagen. Comminuted collagen was incorporated into a variety of foods including breads, pasta and meatloaf. Collagen was a satisfactory extender for breads and pasta. Interestingly, when meatloaf was prepared by incorporating ten percent collagen along with the red meat, it was the consumer taste panel favourite by far. The use of hide collagen for casings already proves the acceptability of this material for food use. The taste panel studies demonstrate that the taste and mouth feel is more than just acceptable.

In the next fifty years, as food protein needs increase, it is likely that a large proportion of the hide corium will end up in high value food products.

### 1.2. The bovine meat packer's paradigm shift

'Paradigm shift' is an over used phrase, as we go into the new millennium. However, I would like to try and make the case that in this prediction the use of the word is appropriate.

Food safety is an ever-increasing concern in the United States and Europe. As populations increase and the size of the food supply and the magnitude of distribution problems increase as well, the issue of food safety will only become greater throughout the world.

In line with this concern to produce safer foods, our laboratory began a joint research project with Monfort Beef, now a division of Con-Agra. The project was directed towards a reduction of bacterial contamination on beef cattle carcasses. This project was initiated by Monfort long before the well publicised *E. coli* problems occurred. The objective was to remove the hair from the carcass before the hide was opened up to remove the meat. It had to be done quickly between stunning and bleeding the animal. The method chosen was to apply a



concentrated solution of sodium sulfide to the carcass immediately after the animal was stunned. Within five minutes it was possible to remove 95 to 98% of the hair, neutralize the alkalinity and oxidize the remaining sulfide. The result is a manure and dirt free, clean and virtually sterile hide to be removed from the carcass after it is bled. No discernible swelling of the grain occurred. At the time, it was felt that successful implementation of this process in packing houses would have a tremendous impact on food safety in the red meat industry.

Early in 1999 the National Cattleman's Beef Association and Con-Agra held a joint meeting to which they invited other meat packers that had not been involved in the project. They presented in detail what was known about a practical unhairing procedure that had been developed and tested on one hundred animals on a pilot plant scale. Complete blueprints for a mechanical design had been completed for the installation of the system in a new meat packing plant several years ago. That installation was never constructed because a solution to handling the effluent from the unhairing system had never been worked out. Our laboratory at the USDA is currently working on such a system and a solution appears to be on the horizon. But even if we do not find the answer this year or next, there is no doubt that the solution will be worked out in the relatively near future. The need for such a system to improve food safety is too great for it to be ignored.

This is great for the meat packing industry but how does it affect the tanner?

### 1.3. The tanning industry paradigm shift

The bovine hide may be split during one of two different steps in today's tanning process. When it is split in the lime, the corium split may be used for many of the applications cited above. If it is split in the blue (after tanning) then the dominant end use of the split is suede leather. Alternative uses, in this latter case, are very limited.

Splitting in the lime means splitting the hide in a swollen condition. This creates a greater thickness variation in the blue crust leather than when splitting is done in the blue. This means that the amount of chrome shavings produced to manufacture uniform thickness blue stock is even greater.

Why not split the hide raw? Raw splitting is controversial right now but in truth it is being done routinely in a variety of locations. And tanners who are using the raw grain splits claim that the thickness of the raw stock you tan is what you get in the final leather. This will actually reduce the accumulation of chrome shavings from the shaving portion of the process.

Up to now the problem has been that the manure and hair on the hide prevent accurate raw hide splitting. Too many thin areas or even holes would be produced in areas where something adheres to the hair side of the hide. This will not be the case with this new raw material that will be produced by the packer. Who will split the raw hide? Most likely the meat packer because he is in the best position to make maximum use of the corium split, particularly in the area of potential food uses for the corium.

## **2. Mechanical changes in hide processing with this new raw material**

### **2.1. Fleshing to scanning to splitting and shaving.**

This continuous first step process will reduce labour, measure area, weight, thickness, the presence of large scars, cuts or brands – with hide specific information that can be carried all the way to the finish area. It will allow correlation of the incoming hide with cutting yield. Computer correlation of the grain image will permit pre-scanning that can become predictive of cutting yield and allowing the tanner to move each individual hide into its most profitable potential product.

Traditional splitting has improved over the years so that the machines can automatically flex in thinner areas of the hide creating more even uniformity in the grain split. This in turn means less shavings are produced in the shaving machine. In the future, this ability to split evenly will only improve.

As mentioned before, one of the advantages of splitting raw hides is that “what you split is what you get” in the thickness of the final leather. This will be further improved in the future, by using a new hide shaving concept. The hide will be drawn tightly against a roll in the shaving machine, similar to the way it is done today, to allow a metal blade to remove the uneven layers of the corium. Only in this case instead of a metal blade, a high-pressure water jet will be used to do the same thing. Thus the production of chrome shavings will be eliminated and at the same time more corium protein (collagen) will be available for food use. These corium shavings resulting from this process could be used in the same way as flaked red meat mechanically recovered from bones.

### **2.2. Benefits to the tanner**

Up to now, the packer seems to be getting the most benefit from the new hide handling process. However, the new raw material will also benefit the tanner. The grain splits from the hides will be received with less than five percent of the original hair and when the system is running optimally probably less than one percent. Hair stubble still remains in the hide and a standard hair burn process will be required to remove all the hair. However, the BOD in the effluent from the beamhouse will be reduced dramatically. In the past, some tanneries recycled the hair burn solutions for several days to a week. With this kind of raw material it may be possible to recycle the unhairing bath indefinitely, with minimal filtering and periodically making up a little sodium sulfide. After unhairing the running time for liming should be significantly shortened because of the thinner and more uniform starting material.

In the tanyard: All running times will be faster because of the shorter distances chemicals will have to move into the stock. This may even help chrome alternatives that otherwise could not compete because of penetration problems.

In all cases up to the blue: A saving of two thirds of the chemicals normally used to produce blue and either smaller or fewer drums would be needed for the same production. This new lighter weight starting material will translate into energy savings and reduce labor costs as well.

Beyond the blue, there will be a few additional differences due to the change in processing at the meat packers but that story will be told later. If the food uses of corium expand, it may even start to compete in value with leather. If, as a result of an expanding corium collagen market, leather then becomes scarcer, its price will rise until there is a balance between the value for food use for the split and the value of leather.

### **3.0. Process evolution**

In the next 25 to 50 years processing equipment for the leather industry will take advantage of new developments in chemistry, materials science, physics, and biochemistry. Developments that are only starting to be researched in 1999 will have been perfected in the next 25 to 50 years. The fact is that some technologies that are in early development stages, in terms of automated processing systems, are beginning to be adopted today. These tanneries do not constitute the 'norm' in terms of making leather at the close of the 20th Century. However, in 25 to 50 years, we should expect that almost all tanneries worldwide will be using these methods. There certainly will continue to be attrition and consolidation among the world's industrialised tanneries - but there will always be a place for the artisan-scale tanning operation, nevertheless using modern technology.

One of the most important problems in the tannery is uniformity of processing from batch to batch, from week to week and from year to year. There are many reasons for variability, from variations in the raw material, to inconsistent chemical quality and non-reproducibility of processing conditions. This latter problem will be solved over the next fifty years by advances in microprocessor control of processing.

#### **3.1. Microprocessors**

The microprocessor only gets better and better. It will be possible to implant or inject a microprocessor in the skin of a young animal that will allow a complete health and growth history of the animal to be recorded. Perhaps in only a few years, but certainly in twenty five these microprocessors will be readable from an airplane or even a satellite. Ranchers will know the health and location of every animal in his herd instantly during the worst of conditions. This chip will continue into the packing plant to allow the meat and the hide to be permanently associated with the rancher and the feed lot that produced them. This will permit the packer to reward the producer for high quality animals. This concept is only being talked about today, but if the red meat industry is to survive, it must begin to reward quality in their raw material and not just final weight.

In the tannery, this chip will continue on through processing with the same result. Identification of the source of high quality hides at the final leather stage will result in higher prices for those hides. Producers who are rewarded will learn what is required to get a higher return on their animals and if it makes good business sense, they will continue to do it. This will begin a cycle that can only improve leather quality in the long run.

#### **3.2. Process Controls**

There are perhaps between 5,000 and 8,000 tanneries in the world today. Maybe there are

3,000 that produce over 200 hides a day. Of all of these, only about 30 have installed automated process controls. Process controls dispense water and chemicals in a reproducible way day in and day out. Reproducible conditions lead to product uniformity and product uniformity leads to customer satisfaction. The end result is more profit both in terms of higher quality product and reduced wastage of chemicals. Without doubt the number of tanneries will decrease even though leather production in square feet will increase. However, in twenty five years all tanneries producing even just 200 hides a day will have some degree of process controls.

The first major breakthrough in process control will be a pH electrode that is well improved over those available in 1999. An electrode must be able to measure a wide range of pH, stabilise in seconds, and last for six months without being poisoned by the usual chemicals used in the tanning process. Other sensors, besides pH electrodes, will be developed that will be able to sense solution absorbance. These sensors will be able to sense the exhaustion of dyestuffs or the uptake of chrome or vegetable tannins.

Sophistication of process controls will go well beyond just measuring chemicals. Microprocessors will be located in the drum along with the stock keeping track of temperature, pH and even chemical concentration. Initially these microprocessors will warn the operators if any of these parameters get out of line. By the turn of the century they will control the process to make the adjustments without using the operator. It goes without saying that these new microprocessors must be able to withstand the usual drum environments of high and low pH and the physical pressure of stock moving in the drum. These sensors will be able to accurately follow the concentration of chemicals in process-vessels (drums), so that the end-point of a process step is not time-related, but depends on the concentration of chemical. This means that the process will be run until all the chemicals are in the leather rather than for a set time period. Instruments will be able to identify the hide with a microchip inserted 0.2-0.4mm under the grain and will carry a complete record of all the processes the hide was exposed to. This chip would resist the shaving, splitting, and setting out operations and be set deep enough to avoid being buffed away in corrected grain leather.

These same instruments will be able to remotely monitor information on the chip and relay it to the control room, for process and production control and automatic adjustment of subsequent processes. This would mean for example that during the dyeing process acid could be automatically added until exhaustion was complete.

### 3.3. Fatliquor, colour, retan

One of the most important advances in the area of fatliquor/colour/retan will be in understanding how to control the affinity of dyes for leather, and how to make the colour 'thrown' by a dye on leather independent of the substrate. This will allow the use of colour matching using a calibrated spectrophotometer assisted by a computer to accurately colour match leather. This is standard technology in the textile industry, but variable results on varying retannages are a source of great difficulty in predicting shades on leather. Continuous monitoring of the drum contents will enable adjustments to be made before drying to further increase uniformity of colour. In the future there is a good possibility of a mechanical assist to accelerate these processes. Ultrasound had been shown to speed up the penetration of

fatliquors and dyes. Speeding up the diffusion of these chemicals into the hide would make the development of feed through processes more realistic.

### 3.4. Drying

Moisture analysis through techniques like infra-red spectroscopy will allow the technician on the floor to know instantly and accurately the amount of moisture in a pack of leather. Knowing the average moisture content of a pack of leather will bring much greater consistency to wet-end processing. This will provide the tanner with the ability to rapidly and accurately dry leather to very low moisture, then "condition" the leather to a target percentage moisture (e.g. 24%) before softening during physical staking or dry milling. Today's methods are imperfect in a number of ways, either allowing for incomplete equilibration of moisture throughout the thickness (throughout the pack) or just drying the leather down to the target value. This does not recognize that leather has to be dried well below the desired final moisture content and then humidified for leather to be made soft and to stay soft.

### 3.5. Finishing

Spray finishing, roller or curtain coating equipment will be developed to automatically adjust the colour of the finish. The output of colour on the leather will be measured automatically and compared to a standard. The mix of pigments in the spray gun or in the other equipment's header tank will be continuously adjusted to maintain the proper colour. Finishing equipment will use ink-jet technology (like current computer printers) to reproduce the beauty of a natural grain or a corrected grain, or low-grade leather. Not forgetting that the need for this kind of solution will diminish, as better animal husbandry is introduced and better care is applied in post-mortem handling of hides. However, this kind of solution will also be applied to materials which are competitive to leather, therefore the industry had better concentrate on producing a high quality, aesthetically attractive version of the "real thing".

Finishing equipment will be designed to finish pre-cut pieces, panels and patterns of leather rather than whole hides or sides. This will reduce the required amount of finish used, reducing VOC emissions and reduce the amount of tanned leather scraps to go to landfills and incineration in trimmings. Recycling of finished leather scraps is one of the most difficult areas in solid waste management in the tannery. A partial solution and probably future development is that some of the leather good manufacturers will finish component pieces themselves. This will assist JIT deliveries for new colours for example.

The last of radiation curing has not been heard of yet either. This process presents some health and safety problems that need to be solved, because of the cross-linking materials used in them. However, as the cost of VOC containment becomes higher, the installation of worker safety equipment for radiation curing becomes more reasonable.

### 3.6. Tannery - general

Completely integrated production systems will be developed. These systems will monitor exactly the quantities of chemicals, dyes and finishes that are being used, correlate this usage

to the physical characteristics of the leather, maintain the output, quality and appearance on database so that cutting values can be accurately known and estimated in future leather batches. These databases will be used in the production planning of the cutting operation, even before the leather has completed the wet processing.

New automated 'instant' methods of determining the quality of leather, using modern physical-chemical means (for example, the already existing use of mass-spectroscopy to determine the amount of chrome in leather) will be developed. This will be expanded to cover other quality characteristics, to minimise the use of trained labour, shorten the time of laboratory determinations, and enable many, many more samples of leather to contribute to the estimate of the quality of a pack. Presently, the low sample rate has little statistical significance, contributing to a feeling of the production staff that the information obtained is almost 'random' from which little can be deduced.

Finally, non-destructive physical property tests will be developed that can be done with much larger numbers of leather sides or hides. Current random statistical testing of leather does not weed out all of the weak leather. Continual testing of acoustic emissions of leather being stretched will become part of routine quality testing.

#### **4. Conclusions**

A large proportion of the chrome tanned leather produced in the world today is of bovine origin. In this area, there will be a major change in the available raw material. The complete value of the hide will be realised in the future, making the packer's most valuable byproduct even more so. Only that portion of the hide that becomes leather will be tanned. The remainder of the corium will go to alternative uses. In the next twenty five years or less, food use is likely to be a major outlet.

This change will not, of course, have great impact on the small skin tanner. However, there will also be major changes in the processing of leather as we know it today. Those changes are not likely to be in terms of new chemistries for tanning, but in improved process control. These changes will improve consistency and quality for all types of animal hides and skins.

#### **Acknowledgement:**

A number of individuals contributed ideas to this paper and I thank them all. In particular, however, I wish to acknowledge the astute and futuristic thinking of John C. Crowther, President of the Swystem Logic Think-Tank.

## **Environmental aspects of future tanning methods.**

**W. Frendrup  
Danish Technological Institute  
Gregersensevej  
PO Box 141  
DK-2630 Taastrup  
Denmark**

<b>Contents</b>	<b>Page</b>
Contents	87
1. The background situation by the year 2050	88
2. Environmental challenges	89
3. Chromium	89
3.1. Environmental regulation and the philosophy behind	89
3.2. Future development and environmental consequences of chrome tanning	90
4. Neutral salts	93
5. Non chrome tannages	94
5.1. General	94
5.2. Mineral tannages	94
5.3. Organic tannages	95
5.3.1. General	95
5.3.2. Vegetable tanning	95
5.3.3. Synthetic organic tannages	97
5.4. Economy	98
6. Environmental management	98
6.1. Environmental management schemes, life cycle assessments, and eco-labelling	98
6.2. Perspectives for leather marketing	99
7. References	101



## 1. The background situation by the year 2050

If in the year 2050 anyone should happen to read this, (s)he certainly is going to wonder and to smile. Predictions of this kind are bound to be more or less perspicacious extrapolations of present trends, other things being equal. But other things are never equal.

In the following, I sometimes use the first person to indicate that the scenario is based on subjective considerations.

We have to think of a world with approximately 10 billion ( $10^{10}$ ) inhabitants. This implies a strong pressure on the global food resources and consequently a strong demand for agricultural area and effectivity as well as sustainability of the agricultural production. This sustainability includes an effective preservation of e.g. the rain forest.

Probably around 2050, energy problems have been more or less solved, as fusion energy is being put into practical use (although there still will be an upper limit for how much energy it is acceptable to produce).

These factors will leave their mark on environmental measures and regulation. In many respects, environmental demands are going to be tightened up, in other respects alleviated. For instance, the use of sludge in agriculture is going to get a high priority, leading to stricter limits for some parameters and, on the other hand, repealing of limits and restrictions without any scientific justification.

Secondary or even more extensive waste water treatment will be obligatory for towns as well as for tanneries discharging into surface waters. This, added to the population increase, leads to a drastic increase in the amount of sludge generated. To some extent, this will be counteracted by cleaner production in the industry, as well as preventive measures concerning waste water from other sources.

Environmental regulation as well as its enforcement has become uniform around the globe, with due consideration for local conditions. Generally, the required efficiency of environmental measures is going to be substantially higher than today, and costs are increasing with the efficiency more or less exponentially.

The leather industry is going to exist as long as meat is eaten. It is only going to disappear if the world goes vegetarian or animal protection activists gain power.

However, the population and the demand for e.g. shoes is growing faster than meat consumption and hide production, and leather products become luxury items. This should leave room for the necessary environmental expenditure. High efficiency of environmental measures presupposes a high level of technological competence, which will be found in all tanneries existing in 2050.

## **2. Environmental Challenges**

Problems which have to be solved satisfactorily are:

Sustainable raw materials (hides, chemicals, etc.)

Satisfactory utilisation or disposal of all kinds of wastes (waste water, sludge, solid wastes from the production), not only from the tannery itself but also from the leather consuming industries.

For all kind of wastes it is true that prevention is better than utilisation and utilisation better than disposal.

Occupational safety.

No health risks to consumers (allergies, etc.)

Environmentally acceptable disposal of final products (waste leather articles).

General good housekeeping is a matter of course in all tanneries existing in 2050.

## **3. Chromium**

### **3.1. Environmental regulation and the philosophy behind**

*Present limit values (cf. (1)) are very strict:*

	Most strict values	Median values
	(ppm Cr)	
Discharge to sewer	0.8	3.5
Discharge to surface water	0.05	1.5
Sludge to agriculture	100	600

The limit values refer to Cr(III) where valency is specified, otherwise to total Cr.

To this must be added the fact that in some cases when a tannery discharges its waste water into a municipal treatment plant, and the municipality is not allowed to apply the sludge to agricultural soil, due to its chromium content, the tannery will have to pay the surplus costs arising from this. Already, a Danish tannery has to pay 150 USD per kg Cr discharged, besides the normal waste water tax (approx. 3 USD/m<sup>3</sup>). In another Danish municipality, the payment is 675 USD per kg Cr discharged.

Problems motivating this strictness towards Cr(III) are to a great extent without any risk based on justification, but mainly of psychological nature. The psychological reasons are:

1. Cr is classified as a heavy metal and by many authorities considered to be similar to e.g. mercury.
2. While scientists almost uniformly recognise the important distinctions between trivalent and hexavalent Cr, environmental authorities often do not.
3. Waste Cr does not disappear and, due to modern techniques of analysis and relatively low background values, it is easy to demonstrate even a small introduction from outside.

This overshadows the fact that according to overwhelming evidence in the scientific literature, Cr(III) has a very low toxicity, is only slightly soluble, and shows no biomagnification, but on the contrary a biominimisation, as it is very poorly absorbed by plants or animals.

Only in acid, sandy soils may a risk for ground water contamination exist.

The question of oxidation of Cr(III) to Cr(VI) on agricultural soil, which was raised some 20 years ago, has now lost its importance. Under certain circumstances, a small part of Cr(III) may become oxidised (on the surface of alkaline soils in the presence of manganese), but Cr(VI) is reduced back to Cr(III) by organic substances in the soil, and Cr(III) complexed by high molecular weight organic ligands is not readily dissociated and oxidised.

Concerning regulation of Cr content in sludge applied to agricultural soil, two philosophies exist: one is that limits (if any) must be risk based (cf. the decision of the United States Court of Appeals concerning Cr limits), the other, widespread in Europe, is that the concentration of Cr in any soil ought to remain what has been provided by nature.

Personally, I am sufficiently optimistic to assume that in the long run the first mentioned attitude is going to prevail. In a world with 10 billion people, it will be considered bad housekeeping not to utilise all sludge in agriculture, which has not been demonstrated harmful by scientific evidence. Any kind of fertilisers and soil improvers will be in great demand. Under these circumstances, chrome tanning will regain its importance. (Also restrictions on chromium in water and waste water may be alleviated, but in this case the impetus will be less strong). In this context, the fact that chromium is an essential micronutrient may be of limited importance only.

The crucial question is: What is going to happen in the meantime? In the worst case, tanners will have to learn chrome tanning technology once more.

### **3.2. Future development and environmental consequences of the chrome tanning**

Anyhow, the specific chromium discharge is going to be further reduced. The future belongs to high exhaustion tanning rather than precipitation and recovery, if not of other reasons, then because of the neutral salts discharge (cf. section 4) and because the high exhaustion tanning also reduces the amount of Cr leaching out during the wet aftertreatments. Certainly, the high exhaustion tanning methods are going to be improved, but any further reduction of the chromium discharge can be of limited importance, as a high exhaustion is already achievable, and a degree of exhaustion which makes it possible to comply with a limit of e.g. 100 ppm in sludge, will hardly ever become a reality.

From a global perspective, the greatest improvement in this respect will consist in the gaining ground of the high-exhaustion tanning (from approximately 25 to 90% of all chrome tanned leather), supplemented with more extensive use of other known technologies such as lime splitting, reduction of the chrome offer (achieving boil resistance only when necessary), and adequate pH control and a suitable selection of chemicals for the wet aftertreatments.

The technological competence necessary for carrying out all this is found in all tanneries existing in 2050.

With regard to environment, combination tannages that include Cr have no specific advantages, as the reduction of chrome discharge obtained is of minor environmental importance. Environmentally, wet white technology may solve problems connected with solid wastes disposal, or be used in non chrome leather production.

Taking a look at chrome tanning, according to the list of environmental challenges found in Section 2, may be a useful yardstick for an evaluation of alternative tannages:

a) Sustainable raw materials

Although chromium is not a renewable resource strictly speaking, the commercially extractable reserves are sufficient for several centuries, and the chromium consumption of the leather industry counts for only approximately 2.5% of the total consumption. On the basis of (2), the consumption of the tanning industry can be calculated to approximately 85,000 tonnes Cr per year (referring to 1996).

b) Utilisation or disposal of wastes

b1) Waste water

With the use of high-exhaustion tanning and secondary waste water treatment, chrome content in the discharge to recipient creates no problem.

b2) Sludge

The obvious way to dispose of the sludge is to utilise it in agriculture. Other utilisations, e.g. as raw material for the building industry, are not promising. Incineration of the sludge should be avoided, as the sludge by becoming alkaline during the incineration furthers the oxidation to Cr VI, but incineration will hardly be of interest in 2050.

For a tannery with its own waste water treatment, it is impossible to comply with a limit of 100-200 ppm Cr in the sludge dry matter. Under present conditions, the absolute minimum achievable would be 1200 ppm, and that only in a few, optimal cases (3). Presumably, this figure is not going to be lower in 2050, as reduction of the chromium discharge and of the suspended solids discharge are probably going to keep pace.

If the tannery discharges into a municipal plant, compliance may indeed be possible, according to the dilution.

Under the conditions prevailing in 2050, authorities and tanneries can probably agree on a concentration limit acceptable for both, say 3,000 ppm.

What is said above (b1 – b2) refers to tanneries with a complete processing from rawhides to crust or finished leather. For tanneries processing wet blue, the situation is somewhat different.

### b3) Solid leather waste

Unfinished chrome leather waste will be utilised. Probably, leatherboard production will still exist and still consumes only a part of the waste. Most of the remaining will be hydrolysed, and the fractions of the hydrolysate utilised. A substantial percentage of the protein hydrolysate is going to be used as an organic fertiliser.

Composting of chrome leather waste is not realistic, as it is too resistant towards biological degradation.

It is more difficult to convert finished leather waste into usable products, and probably part of this waste will still have to be incinerated. The incineration must be carried out in a way that generation of Cr(VI) is avoided. (Experience shows that when smaller amounts of chrome leather are incinerated with domestic refuse, oxidation does not take place to any demonstrable extent).

- c) Occupational health and safety. No problems which have not been overcome.
- d) Health risks to consumers. No demonstrable traces of Cr(VI) are allowed in the finished leather, as Cr(VI) may provoke allergies. As persons with a chrome allergy in many cases cannot use chrome leather articles, non chrome leather articles must be available.
- e) To sum up, the most important environmental drawback of chrome tanning is the solid wastes disposal (except perhaps the neutral salts discharge, see section 4). A minor problem is that chromium is not a renewable resource strictly speaking (see above). Even, when the attitude to chromium has become less negative, the disposal of leather waste may be more difficult when containing chrome.

Of the two life cycle assessments (LCA's) concerning chrome tanning, known to the author (4) (5), the first compares chrome tanning to vegetable tanning. The conclusion is: "Vegetable tanned leather generates less environmental impact through its life cycle than chrome tanned leather. However, the difference is not great and is mainly a

consequence of the chromium emission and the high energy consumption in the production of chrome tanning agents". As mentioned above, both these factors will have lost much of their importance in 2050.

In the second LCA, rather to be called an ecological comparison comprising only the leather production, waste water, sludge, and leather wastes; chrome tanning is compared to glutaraldehyde plus chrome tanning, and to purely vegetable tanning. In this case, it is concluded that each method has its own advantages and drawbacks, and that chrome tanning must be considered an environmentally not very harmful method. Also in this case, the major drawback is considered to be chrome in the sludge.

#### **4. Neutral salts**

Without any doubt, neutral salts are going to become a more serious problem than chromium. Restrictions on the discharge of dissolved solids are becoming a reality, not only in dry climates but generally, in order to protect the fresh water resources of the earth. This development is relevant not only for chrome tanning, but also for any kind of tanning.

Already at present, the discharge limits necessitate cleaner production. On the basis of (1), present limits can be summarised as follows:

		<b>SO<sub>4</sub><sup>2-</sup></b>	<b>Cl<sup>-</sup></b>	<b>COD</b>
		<b>mg/l</b>	<b>mg/l</b>	<b>mg/l</b>
Discharge to Surface water	Most strict values	40	200	30
	Median values	1000	1000	225
Discharge to sewer	Most strict values	100	300	100
	Median values	300	2250	850

The limits are inevitably going to be lowered.

Any kind of salt removal by membrane technology or otherwise must include a utilisation or at least an environmentally acceptable way of disposal of the concentrate or residue. Even if a technology of this kind becomes technically and economically viable for tanneries, the discharge of neutral salts from the production must be minimised, and to the greatest possible extent, the rawhides delivered in a salt free condition.

Chrome tanning must be carried out with a salt free pickling or without any pickling. Any concomitant increase of the COD must be avoided. Furthermore, the content of surplus sodium sulphate in the tanning agent preparation must be phased out. Concerning the chrome tanning agent itself, a substitution of sulphate complexes with basified chromium salts of an organic acid is desirable, although it entails an increase in the COD. Also the discharge of neutral salts deriving from basification must be minimised.

Some relocation of the tanning industry to sites near the open sea is going to take place.

## **5. Non chrome tannages**

### **5.1. General**

In reality, as stated in Section 3.2, chrome tanning has only a few ecological drawbacks. This means that any alternative tanning must have a low environmental impact and, compared to chromium, make the solid waste disposal easier.

All tanning agents react by definition with protein. However, at the same time as they have to react strongly with collagen, they should ideally not react at all with human tissue or micro- and macroorganisms. The keyword is selectivity, a quality chrome tanning agents possess to a high degree. As far as possible, any other tanning agent must be comparable to chromium in this respect.

Another important aspect is the environmental consequences of producing the tanning agent in question.

### **5.2. Mineral tannages**

The only other practical possibilities seem to be aluminium, titanium, and zirconium.

Compared to chromium, aluminium has two psychological advantages: It is not a heavy metal and it is ubiquitous in nature, which means that an introduction of aluminium is less easily observable than is the case for chromium. Aluminium is used as a coagulant for waste water.

However, the use of aluminium raises its own environmental problems. Aluminium is substantially more soluble than chromium; in water with pH <5.5, where it is found in naturally acid waters or in regions with acid rain, it can be dissolved in concentrations toxic to fish or with harmful effects on plant roots.

The generation of acid rain has probably been eliminated by 2050, but nevertheless a weighing of the environmental advantage of aluminium (generation of sludge without chromium) against its drawback (higher solubility and toxicity) will show that there is nothing to be gained environmentally by substituting chromium with aluminium.

In some countries, limits for aluminium concentration in waste water, surface water, or drinking water, are lower than the corresponding limits for chromium(III).

Neither titanium nor zirconium compounds have any known biological significance. Generally, they have a low solubility, are poorly absorbed and retained by plants and animals, and have an extremely low toxicity when in contact with human or animal tissues.

From an environmental point of view they are ideal tanning agents, but the low reactivity which make them harmless in the external and internal environment, at the same time reduces their practical value as tanning agents.

### **5.3. Organic tannages**

#### **5.3.1. General**

Contrary to mineral tanning agents, organic tanning agents “disappear” when reacting with collagen, with activated sludge, or with substances in the soil. Consequently, leather waste and tannery sludge do not appear substantially different from other organic wastes. Furthermore, organic tanned leather is normally more easily biodegradable than chrome leather.

#### **5.3.2. Vegetable tanning**

Tannins are not regarded as hazardous, as they occur in the nature, in plants as well as in soil. However, they are produced by plants as a protection against biological enemies, which implies that they are toxic towards these organisms. They are reasonably compatible with the human physiology (as an inveterate tea drinker I can bear witness to that).

Vegetable tannins are only going to be qualified as a renewable resource, insofar as they are obtained either within eco-compatible plantation programmes or by harvesting from natural species (fruits, leaves, etc.). As far as possible, remaining parts of trees felled or material harvested must be utilised for other purposes. Because of the great need for area for food production, production of vegetable tannins will necessarily get a lower priority and is



probably going to be concentrated in areas which cannot be otherwise utilised. Thus, the production of vegetable tannins is hardly going to increase, rather the opposite.

Use of genetically modified species for increased tannin production is a possibility. In 2050, genetic engineering is going to be a normal and necessary practice in agriculture and is consequently not considered ecologically negative. However, it is doubtful whether tannin production will be judged important enough for a development of this kind.

According to Germann (7), the present consumption of vegetable tanning agents is approximately 250,000 tonnes/year. A complete substitution of chrome with vegetable tannins would entail a yearly consumption of 2-3 mill. tonnes/year, which is totally unrealistic.

Environmental pollution, occupational health problems, and energy consumption by the production of the tanning agent are less than is the case with chrome tanning agent.

Vegetable leather is easily biodegradable and compostable; vegetable tannins are ubiquitous in decaying plant materials in or upon the soil, and vegetable tannins in sludge or decaying leather make no difference in this respect.

However, the waste water is problematic. The colour may be difficult to eliminate, and COD before and after waste water treatment is higher than is the case for chrome tanning, and a third treatment stage, e.g. with activated carbon, is going to become necessary.

Most problematic is the discharge of neutral salts, deriving from the salt content of the extracts as well as from the pretreatments. It is desirable or probably necessary to optimise the tanning itself, to eliminate non-tannins from the extracts (this might be possible through membrane technologies, but would the costs be viable, and again, what about the concentrate?), and to eliminate pretreatments of the hide or pelt with sodium sulphate or phosphorus compounds.

In the environmental analysis (5), vegetable tanning was found to result in the highest loads of waste water, sludge and other solid wastes. The advantage, indeed, was the easy disposability of the solid wastes.

The argument heard in the present time, that it is a positive property of vegetable leather that it is "natural", has no real value. As Heidemann rightly points out (6), the natural

function of the vegetable tannins is to defend the plant by killing other organisms; and in general, “nature” comprises not only life and death, but also killing and murder. Probably the fascination of the notion “natural products” is going to lose its force.

Vegetable tanning is never going to be an alternative to chrome tanning. If anything, its relative importance is going to decline, due to supply as well as waste water problems. However, in 2050 it will probably still be used for some purposes.

### **5.3.3. Synthetic organic tannages**

Real alternatives to chrome tanning must be found among the synthetic organic tanning methods. All crosslinkers for proteins are potential tanning agents and it must be expected that in 2050 organic substances and reactions which nobody as yet have thought of for this purpose will be used for tanning.

Also these tannages must fulfil the same requirements as chrome tanning (high exhaustion, low discharge of neutral salts and COD, and a low occupational health risk).

Problems with regard to the internal and external environments, following from the production of synthetic tanning agents, are too varied to be discussed here.

The problem is occupational health and safety risks. Tanning agents should at the same time crosslink proteins and have no negative physiological effects, a more or less self-contradictory demand.

Monomer organic tanning agents are toxic and consequently demand protective measures in the working place. On the other hand, polymers used in the tanning process are in most cases physiologically harmless, but can only be used as auxiliary tanning agents.

Probably, before 2050 systems with a satisfactory tanning effect but at the same time less hazardous have been developed. Nevertheless, more extensive – and expensive – protection measures than in the case of chrome tanning will probably still be necessary.

Many syntans in the classical sense are polymers and at the same time fully satisfactory

tanning agents due to their phenolic and sulphonic acid groups. Syntans, making possible the production of high quality leather with minor environmental consequences, are probably still going to be used in 2050.

The syntans found at present are of a strongly varied biodegradability in waste water. Syntans with a low biodegradability and a low efficiency of COD elimination are going to be phased out.

Of the four tanning methods compared in (5), glutaraldehyde pretanning followed by a main tanning with syntan had the lowest discharge of neutral salts, but a significantly higher COD discharge than the chrome tanning.

Even if, as I suppose, chromium has been rehabilitated by 2050, is it hardly going to regain its market completely, as in all probability synthetic organic tannages will be developed which can compete with or surpass chromium tannage with regard to leather properties and/or process technology.

#### **5.4. Economy**

A Danish upholstery leather tannery has converted the production to non chrome leather exclusively. The costs of tanning agents is 20% higher, the total production costs 2-5% higher than the corresponding costs for chrome leather (8).

Other information indicates surplus production costs in the magnitude of 30% (9) or even 150% (10). This is probably a question of the choice of tanning agent and the production scale.

### **6. Environmental management**

#### **6.1. Environmental management schemes, life cvclus assessments, and eco-labelling.**

Environmental management schemes have come to stay; future schemes are going to resemble EMAS (EU Eco-Management and Audit Scheme) rather than ISO 14000 (International Standards Organisation), i.e. including independent verification, demands to the environmental standard of subcontractors and a continuous improvement of the environmental standard. Public environmental accounts of companies will become a normal

feature.

Life cyclus assessments (LCA's) are certainly going to be important, also in 2050. However, in the last resort a LCA is a subjective evaluation, as selection and weighing of the various parameters forming parts of a LCA are subjective, depending on the prevailing scientific opinions, a priori assumptions, practical circumstances, and political correctness at the time the LCA is carried out (e.g. does the "greenhouse" problematic turn out to be real or a hoax, and if real, is a warming of the atmosphere going to be evaluated as positive or negative, all things considered, in 2050? Furthermore, is the energy produced from fossile fuel or by fission at that time?). Nobody can tell how the weighing is going to be carried out in 2050, and consequently it is hardly possible to predict the impact of LCA's on the leather industry at that time.

Whether eco-labelling does still exist in 2050 depends indeed on the consumers' interest. Eco-labelling may become obsolete when environmental regulation and its enforcement have reached a uniform high level around the world, but it is also very well possible that there still exists a demand for articles produced even more environmentally friendly than prescribed. The attitude of customers is if possible even more difficult to predict than the weighing of parameters in LCA's.

Anyhow, the attitude of customers is going to become more uniform around the world.

The buy and throw away mentality discourages the interest for eco-labelling, but the trend towards leather becoming a luxury item will make leather articles belong to the categories of goods whose quality, durability, and probably also ecological properties distinguish them from cheaper materials.

Sooner or later, at least before 2050, the leather industry will have to provide for removal of discarded leather articles and their utilisation for some purpose or other. Incineration must be the last resort. This raises the question whether a chromium content is a hindrance for any potential utilisations.

## **6.2. Perspectives for leather marketing**

In all probability, leather has a future as an ecologically sound material, not least because the hides are a renewable resource and a byproduct which is best utilised for leather production.

From a rational point of view, the non chrome tanning methods should provide the tanner with a useful alternative, but not to replace chromium completely. The main ecological advantage of the non chrome tannages is that they open up far more possibilities with regard to utilisation or disposal of solid wastes, important in at least the nearer future.

If non chrome leather is marketed as environmentally preferable, it follows by implication that chrome leather is environmentally unfriendly.

The Danish tannery, referred to above, developed their non chrome leather, not because of marketing reasons, but because they had to pay an exorbitant tax for their chromium discharge (cf. section 3.1). Only very few of their customers ask for a non chrome, "ecological" leather; most customers are only interested in the leather itself; some customers even demand that the tanning method is not mentioned, as they also use chrome leather in their production.

Within some years, the tannery may be compelled to stop the production of chrome leather and then market their leather as "eco-leather".

The situation may arise that in some part of the world (e.g. Europe) predominantly non chrome leather is demanded, whereas in other parts of the world, chrome leather is in greatest demand. In 2050, however, the situation has probably stabilised in the way that both leather types are appreciated according to their respective inherent qualities.

## 7. References

1. J. Buljan: Pollution limits for discharge of tannery effluents into water bodies and sewers. *World Leather* Nov. 1996, p.65.
2. G. Reich: Theorie und Praxis der organischen Gerbstoffe. *Das Leder* 47, 74-83, 157-171 (1996).
3. W. Frendrup: Practical possibilities for cleaner production in leather processing. Danish Technological Institute, 1999.
4. C.T. Mikkelsen: Life cyclus analysis of the leather industry. Project report, Danish Technical University, 1993 (in Danish).
5. B. Trommer, H.J. Kellert: Ecological comparison of various tannage types. *Leder- und Häutemarkt* No. 6, 25-36 (1999).
6. E. Heidemann: Comment to a paper by Leelapriya et al., *Das Leder* 44, 21-25 (1993).
7. H.P. Germann: State-of-the-art research for an ecological leather production and development trends. *Leder- und Häutemarkt* 47, No. 9. (5/5 1995).
8. Personal communication, Swewi Svendborg A/S.
9. J.P. Schomisch: Why not with rhubarb? *Leder- und Häutemarkt* 49, No. 2. (24/1 1997).
10. Eco-friendly line from Portugal. *Leather News*, Expo Center Sharjah 3, No.4. (1998).