



TOGETHER
for a sustainable future

OCCASION

This publication has been made available to the public on the occasion of the 50th anniversary of the United Nations Industrial Development Organisation.



TOGETHER
for a sustainable future

DISCLAIMER

This document has been produced without formal United Nations editing. The designations employed and the presentation of the material in this document do not imply the expression of any opinion whatsoever on the part of the Secretariat of the United Nations Industrial Development Organization (UNIDO) concerning the legal status of any country, territory, city or area or of its authorities, or concerning the delimitation of its frontiers or boundaries, or its economic system or degree of development. Designations such as “developed”, “industrialized” and “developing” are intended for statistical convenience and do not necessarily express a judgment about the stage reached by a particular country or area in the development process. Mention of firm names or commercial products does not constitute an endorsement by UNIDO.

FAIR USE POLICY

Any part of this publication may be quoted and referenced for educational and research purposes without additional permission from UNIDO. However, those who make use of quoting and referencing this publication are requested to follow the Fair Use Policy of giving due credit to UNIDO.

CONTACT

Please contact publications@unido.org for further information concerning UNIDO publications.

For more information about UNIDO, please visit us at www.unido.org

22238

OFFICE : No. 201
Mahestan Bld.
Enghelab Sqr.
TEHRAN IRAN
Tel. 00 98 21 6432854
Fax 00 98 21 6420759

ICRC

Industrial Control
Research Center

Yazd Arg Metal Final Report (Page 1)

REPORT

CONVERSION OF

YAZD ARG METAL Co.

HOT CHAMBER

FINAL REPORT

Contract No. 99/131P

UNIDO's PROJECT No. MP/IRA/98/087

30 Oct 99

Factory : No. 4 Street Iraqui Street Rajaii. TEHRAN IRAN
Telfax 0098-21-5052836 Po.Bo. 18915-133

OFFICE : No. 201
Mahestan Bld.
Enghelab Sqr.
TEHRAN IRAN
Tel. 00 98 21 6432854
Fax 00 98 21 6420759



Yazd Arg Metal Final Report (*Page 2*)

TABLE OF CONTENTS

1-SYNOPSIS

2-INTRODUCTION

3-ICRC HOT CHAMBER CHARACTERISTICS

4- PLANT HOT CHAMBER, TECHNICAL CHARACTERISTICS

5- CENTER HOT CHAMBER TECHNICAL CHARACTERISTICS

6-ACTIVITIES

7 SUPPLY PARTS AND MATERIALS

8-CONCLUSION

9-RECOMMENDATION

10-ATTACHMENTS

Factory : No. 4 Street Iraqui Street Rajaii. TEHRAN IRAN
Telfax 0098-21-5052836 Po.Bo. 18915-133

OFFICE : No. 201
Mahestan Bld.
Enghelab Sqr.
TEHRAN IRAN
Tel. 00 98 21 6432854
Fax 00 98 21 6420759



Yazd Arg Metal Final Report (*Page 3*)

SYNOPSIS

Under supreme supervision of **UNIDO** the **CFC** phase project has been implemented in Iran to phase out 100 % ODS in some Iranian White Industries

The project No. **MP/IRA/98/087** has been nominated to Islamic Republic of Iran for the Multilateral Fund for the implementation of The Montreal Protocol Financing.

The project was approved by Montreal Protocol Multilateral Fund executive committee. The project was actually started in November 1994, but the implementation of the project has been already started from January 1994, by recommendation of Montreal Protocol and request of Government of Islamic Republic of Iran, the refrigerant R134a was finally approved and selected by **UNIDO** as an alternative for refrigerant R12.

Yazd Arg Metal Co. As a home appliance manufacturer in Iran the main activities of *Yazd Arg Metal Co.* , is producing refrigerators and freezers,

Factory : No. 4 Street Iraqui Street Rajaii. TEHRAN IRAN
Telfax 0098-21-5052836 Po.Bo. 18915-133

OFFICE : No. 201
Mahestan Bld.
Enghelab Sqr.
TEHRAN IRAN
Tel. 00 98 21 6432854
Fax 00 98 21 6420759



Yazd Arg Metal Final Report (*Page 4*)

INTRODUCTION

According to **UNIDO** contract No. **99/131P** with Industrial Control Research Center Co. (**ICRC**) the existing *Yazd Arg Metal Co.* hot chambers facilities shall be converted and modified to phase out CFC-12 and suitable for **R134a** refrigerant to perform functionality and performance test of converted refrigerators and complying with ISO standards 7173, 8187, and 5155.

- 1 This proposal has been prepared based on the requirements of Islamic Republic of Iran indicated in the country program no *UNEP/OZL.PRO/EX COM/10/24* dated 27 May 1993 prepared by **UNDP**.

Factory : No. 4 Street Iraqui Street Rajaii. TEHRAN IRAN
Telfax 0098-21-5052836 Po.Bo. 18915-133

OFFICE : No. 201
Mahestan Bld.
Enghelab Sqr.
TEHRAN IRAN
Tel. 00 98 21 6432854
Fax 00 98 21 6420759



Yazd Arg Metal Final Report (*Page 5*)

- 2 The CFC phase out project in *Yazd Arg Metal Co.* will enable *Yazd Arg Metal Co.* to convert the existing production line facilities and existing hot chambers into Non CFC production line, using R134a refrigerant.

- 3 The converted Hot Chamber Installations will provide more than 20 data points in the refrigeration circuit this means more information and the ability of analyzing refrigeration system and new refrigerant effect.

- 4 The reconstructed Hot Chamber will be able to check and test 2 refrigerator and/or ref.-freezers units at the same time. The same equipment and data processing system, as will be used at plant test room will be installed in this chamber.

- 5 The immediate effect of this project at *Yazd Arg Metal Co.* is to perform all required check and tests, suitable for Refrigerator & Freezers using Ozone Friendly Gases. The existing test facilities in *Yazd Arg Metal Co.* are not adequate for check and testing, converted ref. and freezer units, in addition to that the hot rooms are not able to perform Energy Consumption and Optimization Program.

Factory : No. 4 Street Iraqui Street Rajaii. TEHRAN IRAN
Telfax 0098-21-5052836 Po.Bo. 18915-133

OFFICE : No. 201
Mahestan Bld.
Enghelab Sqr.
TEHRAN IRAN
Tel. 00 98 21 6432854
Fax 00 98 21 6420759



Yazd Arg Metal Final Report (Page 6)

ICRC Hot Chamber Characteristics

In order to convert *Yazd Arg Metal Co.* hot rooms facilities , ICRC shall provide following services:

- Supply of new equipment.
- Redesign of old equipment
- Delivery of technical drawings and software.
- Installation and commissioning.
- Start-up of the equipment and the technology.
- On-the-job training of the plant personnel.

With respect to **ISO** standards test requirements, and for the purpose of functionality and performance tests of the new redesigned Refrigerator and Ref.-Freezers using R134a refrigerants. The existing hot room in *Yazd Arg Metal Co.* is being converted and equipped in such a way to enable *Yazd Arg Metal Co.* to check and test at least one different models of refrigerators and freezers at ambient temperature 32 to 43 degree centigrade at one hot room chambers . In addition to these services is providing. But the hot room is capable to test eight refrigerators and freezers in case of adding more transducers and sensors in the main panel in the hot room:

- a) Procurement of new test measurement and data processing equipment.
- b) Redesign and rebuilding of presently used equipment and installation.
- c) Installation, commissioning, trial operation, start-up and on-the-job training

Factory : No. 4 Street Iraqui Street Rajaii. TEHRAN IRAN
Telfax 0098-21-5052836 Po.Bo. 18915-133

OFFICE : No. 201
Mahestan Bld.
Enghelab Sqr.
TEHRAN IRAN
Tel. 00 98 21 6432854
Fax 00 98 21 6420759



Yazd Arg Metal Final Report (Page 7)

YAZD ARG METAL HOT CHAMBER TECHNICAL SPECIFICATION

As previously mentioned , *Yazd Arg Metal Co.*'s plant is producing 50 refrigerator daily . And subsequently the hot chamber should have been able to cover plant daily test requirement as well as other activities. Therefore, the converted hot chamber should respond to all test requirement and be able to meet ISO standards numbers 7371, 5155, 8187 as set forth in the contract and IJISI, Iranian standards numbers 254, 2482, 2818. The plant hot chamber technical specification are as follows:

- Hot Chamber Dimension about 3 mt. by 3 mt.
- Refrigerator test ability simultaneously, 2 units and ability to test 6 sample out of the room
- Ability to perform following operational tests and report:
 - 1 - Pull down test.
 - 2 - Continuous run test.
 - 3 - Cyclic run test.
 - 4 - Ice Freeze test.
 - 5 - Energy consumption test

Factory : No. 4 Street Iraqui Street Rajaii. TEHRAN IRAN
Telfax 0098-21-5052836 Po.Bo. 18915-133

OFFICE : No. 201
Mahestan Bld.
Enghelab Sqr.
TEHRAN IRAN
Tel. 00 98 21 6432854
Fax 00 98 21 6420759



Yazd Arg Metal Final Report (*Page 8*)

- 20 Measuring points, including. (for each applia.)

- 1 - Humidity, one point for one hot room.
- 2 - Compressor Power, 2 point
- 3 - Motor current, 2 point.
- 4 - Supply Voltage, 2 point.
- 5 - Hot chamber air temperature reading, one point.

160 points for eight models in case of improving the system by spending very low costs.

- Computerized graphical diagram of the refrigerator performance data sheet.
- Test measurement tolerance for temperature reading 0.3 degree centigrade.
- Computerized data processing system.
- Full color test sheet system reporting.

Factory : No. 4 Street Iraqi Street Rajaii. TEHRAN IRAN
Telfax 0098-21-5052836 Po.Bo. 18915-133

OFFICE : No. 201
Mahestan Bld.
Enghelab Sqr.
TEHRAN IRAN
Tel. 00 98 21 6432854
Fax 00 98 21 6420759



Yazd Arg Metal Final Report (*Page 9*)

- On screen and data reporting system ability with following characteristics;

- 1 - Test number.**
- 2 - Product name.**
- 3 - Product model**
- 4 - Product internal volume**
- 5 - Compressor name**
- 6 - Compressor model**
- 7 - Compressor cooling capacity**
- 8 - Compressor current**
- 9 - Thermostat setting**
- 10 - Thermostat type.**
- 11 - Total test running time.**
- 12 - Ambient temperature.**
- 13 - Voltage rating**
- 14 - Working percentage**

Factory : No.4 Street Iraqui Street Rajaii. TEHRAN IRAN
Telfax 0098-21-5052836 Po.Bo. 18915-133

OFFICE : No. 201
Mahestan Bld.
Enghelab Sqr.
TEHRAN IRAN
Tel. 00 98 21 6432854
Fax 00 98 21 6420759



Yazd Arg Metal Final Report (*Page 10*)

- 15 - Evaporator mean air temperature**
- 16 - Cabin mean temperature**
- 17 - Evaporator bulb temperature**
- 18 - Crisper temperature.**
- 19 - Actual compressor running time**
- 20 - Energy consumption**
- 21 - Compressor motor winding temperature**
- 22 - Compressor shell temperature.**
- 23 - Compressor discharge temperature.**
- 24 - Condenser inlet temperature.**
- 25 - Condenser out let temperature.**
- 26 - Condenser mid temperature**
- 27 - Evaporator inlet temperature**
- 28 - Evaporator outlet temperature.**
- 29 - Freezing temperature.**
- 30 - Refrigeration system condition display.**

Factory : No. 4 Street Iraqui Street Rajaii. TEHRAN IRAN
Telfax 0098-21-5052836 Po.Bo. 18915-133

OFFICE : No. 201
Mahestan Bld.
Enghelab Sqr.
TEHRAN IRAN
Tel. 00 98 21 6432854
Fax 00 98 21 6420759



Yazd Arg Metal Final Report (Page 11)

ACTIVITIES

The following activities were accomplished so far toward achievement of the contract requirement as set forth by **UNIDO** and the counterpart.

- 1 - Planning for;
 - a) Hot chambers system management.
 - b) Hot chambers graphic display management.
 - c) Hot chambers calibration setting parameters.
 - d) Hot chambers test standards management
- 2 - Preparing material requirement list.
- 3 - Component and material supply source evaluation.
- 4 - Technical data collecting.
- 5 - Engineering drawing for electronic and electrical system
- 6 - Hot chamber design review.

Factory : No. 4 Street Iraqui Street Rajaii. TEHRAN IRAN
Telfax 0098-21-5052836 Po.Bo. 18915-133

OFFICE : No. 201
Mahestan Bld.
Enghelab Sqr.
TEHRAN IRAN
Tel. 00 98 21 6432854
Fax 00 98 21 6420759



Yazd Arg Metal Final Report (*Page 12*)

- 7 - Data processing software planning.
- 8 - Data processing hardware planning.
- 9 - Thermal amplification electronic cart design
- 10 - Preparation of timer 1 flow chart..
- 11 - Initial test of data loggers electronic cart.
- 12 - Initial connection of data loggers to the computers.
- 3 - Interface electronic cart design for PC and operating system.
- 4 - RTX3 electronic diagram design.
- 5 - RTX electronic diagram design.
- 6 - UNIDO, CRC - 386 design.

U [REDACTED]

J [REDACTED]

[REDACTED]

[REDACTED]

OFFICE : No. 201
Mahestan Bld.
Enghelab Sqr.
TEHRAN IRAN
Tel. 00 98 21 6432854
Fax 00 98 21 6420759



Yazd Arg Metal Final Report (*Page 13*)

20 - Visits and coordination;

20/1 :

- Visiting plant One day, One engineer, one time.
- Visiting and coordinating with UNDP office .
- Technical negotiation with *Yazd Arg Metal Co.* engineers and hot chamber in order to coordinate activities.
- Advising for the necessary modification on the Room .

20/2 :

- Visiting plant 3 days , 5 engineer and Technician, one time.
- Installation Electronic Panel
- Installation Electrical Panel
- Completing The Room
- Starting Test
- Controlling Condition Of the Room
- Testing 2 Samples for Energy Consumption
- Testing 2 Samples for Performance Test
- Testing 2 Samples for Fume Quality
- Teaching the technical Test

Factory : No. 4 Street Iraqui Street Rajaii. TEHRAN IRAN
Telfax 0098-21-5052836 Po.Bo. 18915-133

OFFICE : No. 201
Mahestan Bld.
Enghelab Sqr.
TEHRAN IRAN
Tel. 00 98 21 6432854
Fax 00 98 21 6420759



Yazd Arg Metal Final Report (*Page 14*)

- Visiting and coordinating with **UNDP** office .
- Technical negotiation with *Yazd Arg Metal Co.* engineers and hot chamber in order to coordinate activities.
- Advising for the necessary modification on the Samples .

21 - Soft Ware :

- data gathering
- calibrating
- printing
- editing
- humidi curving
- self checking

All software are installed and Started

Factory : No. 4 Street Iraqui Street Rajaii. TEHRAN IRAN
Telfax 0098-21-5052836 Po.Bo. 18915-133

OFFICE : No. 201
Mahestan Bld.
Enghelab Sqr.
TEHRAN IRAN
Tel. 00 98 21 6432854
Fax 00 98 21 6420759



Yazd Arg Metal Final Report (Page 15)

SUPPLY PARTS AND MATERIALS

In order to fabricate components and electronic kits following material and parts have been purchased so far.

- 1 - Semiconductor sensors for measuring temperature from - 30 to + 110 degree centigrade. 32 each
- 2 - Electronic humidity measurement sensor 1 each
- 3 - Electronic data logger cart for temperature measurement 2 each
- 4 - Electronic data logger cart for humidity Calibration 1 each
- 5 - ADC912 Converter IC for system conversion management.
- 6 - Electronic parts consist of resistor. IC, capacitor, and diode.
- 7 - Main Electronic Data Log
- 8- (2*24) Electronic Sensors for Thermal Measuring
- 9- (2*4) Electronic Sensors for Thermal Measuring of Condenser
- 10-Heater Controller contractors

Factory : No. 4 Street Iraqui Street Rajaii. TEHRAN IRAN
Telfax 0098-21-5052836 Po.Bo. 18915-133

OFFICE : No. 201
Mahestan Bld.
Enghelab Sqr.
TEHRAN IRAN
Tel. 00 98 21 6432854
Fax 00 98 21 6420759



Final Report (Page 16)

Dim Black, Blue, Green
Dim Cyan, red, Magenta, YELLOW
Dim gray, L_Blue, L_Green
Dim L_cyan, L_red, L_Magenta, L_yellow

Dim prn_color As Integer 'False=Black & White ; True=Color

Dim printcolor As Integer
Dim Y, Repstr\$, Rot_Txt_no%
Dim printerdrawwidth As Integer
Dim offset, PageNo
Dim Lb_Tmp As Label
Dim FirstKey

Dim Rec_Max%
Dim SegEn
Dim ActiveFrame As Integer
Dim ActiveLabel As Integer
Dim Seg_n As Integer

Dim PrnPageNo As Integer
Dim ActivePage As Integer

Dim sl%, st%, sw%, sh%, dw%
Dim a30 As String * 30

Dim rr() 'Extracted Results

Factory : No.4 Street Iraqui Street Rajaii. TEHRAN IRAN
Telfax 0098-21-5052836 Po.Bo. 18915-133

OFFICE : No. 201
Mahestan Bld.
Enghelab Sqr.
TEHRAN IRAN
Tel. 00 98 21 6432854
Fax 00 98 21 6420759



Final Report (Page 17)

'
Sub cmd_click (Index As Integer)

Select Case Index

```
Case 0                                'print
    screen.MousePointer = 11
    Cmd(0).Enabled = False
    Cmd(1).Enabled = False
    DoEvents
    Call Print_All
    Call Save_Spec
    screen.MousePointer = 0
    Cmd(0).Enabled = True
    Cmd(1).Enabled = True
    'Unload Me

Case 1                                'Save
    nn = Variable("Prnt", "Write")
    nn = Variable("Prnt", "Read")

Case 2                                'cancel
    Unload Me

Case 3
    Me.Hide
    Paper.Show
```

End Select

Exit Sub

End Sub

'
Sub Color_chk_Click (Value As Integer)

```
' If color_chk.Value = False Then
'     prn_color = False
```

Factory : No. 4 Street Iraqui Street Rajaii. TEHRAN IRAN
Telfax 0098-21-5052836 Po.Bo. 18915-133

**OFFICE : No. 201
Mahestan Bld.
Enghelab Sqr.
TEHRAN IRAN
Tel. 00 98 21 6432854
Fax 00 98 21 6420759**



Final Report (Page 18)

```
' color = 0
'   Black = color
'   Blue = color
'   Green = color
'   Cyan = color
'   red = color
'   Magenta = color
'   YELLOW = color
'   gray = color
'   L_Blue = color
'   L_Green = color
'   L_cyan = color
'   L_red = color
'   L_Magenta = color
'   L_yellow = color
'
' Else
'   prn_color = True
'   Black = QBColor(0)
'   Blue = QBColor(1)
'   Green = QBColor(2)
'   Cyan = QBColor(3)
'   red = QBColor(4)
'   Magenta = QBColor(5)
'   YELLOW = QBColor(6)
'   gray = QBColor(8)
'   L_Blue = QBColor(9)
'   L_Green = QBColor(10)
'   L_cyan = QBColor(11)
'   L_red = QBColor(12)
'   L_Magenta = QBColor(13)
'   L_yellow = QBColor(14)
' End If
```

End Sub

**Factory : No. 4 Street Iraqui Street Rajaii. TEHRAN IRAN
Telfax 0098-21-5052836 Po.Bo. 18915-133**

OFFICE : No. 201
Mahestan Bld.
Enghelab Sqr.
TEHRAN IRAN
Tel. 00 98 21 6432854
Fax 00 98 21 6420759



Final Report (Page 19)

Sub crv (mode\$, Rec1, Rec2)

Select Case mode\$

Case "prn"

```
printer.ForeColor = Black
printer.FontName = "Arial"
printer.FontSize = 10
obj = ActiveObj

'print x_axis
printer.DrawWidth = 3 * printerdrawwidth
printer.Line (Rec1, 0)-(Rec2, 0)'axis
printer.DrawWidth = 1
printer.DrawStyle = 2'=Dot 3=Dash-Dot 4=Dash_Dot_Dot
For i = -300 To 1000 Step 100
    printer.Line (Rec1, i)-(Rec2, i)
Next i
rec = zoom(Seg_n).X1
printer.DrawWidth = 3 * printerdrawwidth
printer.ForeColor = IIf(prn_color = False, Black,
    zoom(Seg_n).BorderColor)
printer.Line (rec, -300)-(rec, 1000)
printer.DrawStyle = 0 'Solid
printer.DrawWidth = 1 * printerdrawwidth

printer.CurrentX = rec - RecLb(Seg_n).Width / 2
printer.CurrentY = 1030
printer.Print RecLb(Seg_n).Caption

n = -1
R1 = (Rec1 \ 10 + 1) * 10
R2 = (Rec2 \ 10) * 10
```

Factory : No. 4 Street Iraqui Street Rajaii. TEHRAN IRAN
Telfax 0098-21-5052836 Po.Bo. 18915-133

OFFICE : No. 201
Mahestan Bld.
Enghelab Sqr.
TEHRAN IRAN
Tel. 00 98 21 6432854
Fax 00 98 21 6420759



Final Report (Page 20)

```
printer.FontSize = 5
printer.ForeColor = Black
For rec = R1 To R2 Step 10
    printer.Line (rec, 10)-(rec, -10), Black
    n = n + 1
    If n Mod 3 = 0 Then
        b$ = Right$("0" & rec \ 60, 2) & ":" & Right$("0" &
rec Mod 60, 2)
        printer.CurrentX = rec - 2'offset / 13
        printer.CurrentY = -12
        printer.Print b$
    End If
Next rec

'graph
For n = 0 To 1
    For d = 1 To 6
        If curve_Item(n, d) < 50 Then
            z = curve_Item(n, d)
            If curve_color(n, d) = 15 Then col = 0 Else col =
curve_color(n, d)
            printer.ForeColor = IIf(prn_color = False, Black,
QBColor(col))
            For rec = Rec1 To Rec2 - 1
                bool1 = grf(26, rec) = 789
                bool2 = grf(26, rec + 1) = 789
                If bool1 And bool2 Then
                    Y1 = grf(z, rec)
                    Y2 = grf(z, rec + 1)
                    printer.Line (rec, Y1)-(rec + 1, Y2)
                End If
            Next rec
        End If
    Next d
Next n
```

Factory : No.4 Street Iraqui Street Rajaii. TEHRAN IRAN
Telfax 0098-21-5052836 Po.Bo. 18915-133

OFFICE : No. 201
Mahestan Bld.
Enghelab Sqr.
TEHRAN IRAN
Tel. 00 98 21 6432854
Fax 00 98 21 6420759



Final Report (Page 21)

```
Case "grfall"
  On Error Resume Next 'Note:Karim
  obj = ActiveObj
  grafall.Cls
  grafall.DrawMode = 7 ' (7=xor 13=copy)
  RecAll_End = UBound(grf, 2) - 1
  If Err = 9 Then
    Rec_Max = 0
    Exit Sub
  End If
  Rec_Max = RecAll_End
  screen.MousePointer = 11
  sw = IIf(RecAll_End < 100, 100, RecAll_End)
  grafall.ScaleWidth = sw + recall_end \ 10
  grafall.ScaleLeft = 0
  recall_start = 1
  grafall.Line (recall_start, 0)-(RecAll_End, 0), QBColor(3)

  For n = 0 To 1
    For d = 1 To 6
      If curve_Item(n, d) < 50 Then
        z = curve_Item(n, d)
        If Hr.lbt(z).Visible = True Then
          grafall.ForeColor = QBColor(curve_color(n, d))
          For rec = recall_start To RecAll_End - 1
            If grf(26, rec) = 789 And grf(26, rec + 1) = 789 Then
              grafall.Line (rec, grf(z, rec))-(rec + 1, grf(z, rec
+ 1))
            End If
          Next rec
        Else
          curve_Item(n, d) = 50
          Hr.lbt(z).ForeColor = QBColor(0)
        End If
      End If
    Next d
  Next n
```

Factory: No. 4 Street Iraqui Street Rajaii. TEHRAN IRAN
Telfax 0098-21-5052836 Po.Bo. 18915-133

**OFFICE : No. 201
Mahestan Bld.
Enghelab Sqr.
TEHRAN IRAN
Tel. 00 98 21 6432854
Fax 00 98 21 6420759**



Final Report (Page 22)

```
End If
Next d
Next n
screen.MousePointer = 0
Case "grfzoom"
On Error Resume Next
obj = ActiveObj

zoomarea = 30
zoomarea2 = zoomarea \ 2
grafzoom.ScaleWidth = zoomarea
'X = Int(zoom.X1 + .5)
'If X > Rec_Max Then Stop
grafzoom.ScaleLeft = X - zoomarea2

Rec_Start = IIf(X - zoomarea2 > 0, X - zoomarea2, 0)
Rec_end = IIf(X + zoomarea2 < Rec_Max, X + zoomarea2, Rec_Max)

'Rec_Start = Seg(ActiveSeg).Left
'Rec_End = Rec_Start + Seg(ActiveSeg).Width
'grafzoom.ScaleWidth = Seg(ActiveSeg).Width
'grafzoom.ScaleLeft = Rec_Start

grafzoom.Cls
grafzoom.DrawMode = 7 '(7=xor 13=copy)
grafzoom.Line (Rec_Start, 0)-(Rec_end, 0), QBColor(3)
For n = 0 To 1
For d = 1 To 6
If curve_Item(n, d) < 50 Then
z = curve_Item(n, d)
If Hr.lbt(z).Visible = True Then
grafzoom.ForeColor = QBColor(curve_color(n, d))
For rec = Rec_Start To Rec_end - 1
If grf(26, rec) = 789 And grf(26, rec + 1) = 789 Then
grafzoom.Line (rec, grf(z, rec))-(rec + 1, grf(z,
```

**Factory: No. 4 Street Iraqui Street Rajaii. TEHRAN IRAN
Telfax 0098-21-5052836 Po.Bo. 18915-133**

**OFFICE : No. 201
Mahestan Bld.
Enghelab Sqr.
TEHRAN IRAN
Tel. 00 98 21 6432854
Fax 00 98 21 6420759**



Final Report (Page 23)

```
rec + 1))  
        End If  
    Next rec  
Else  
    curve_Item(n, d) = 50  
    Hr.lbt(z).ForeColor = QBColor(0)  
    Hr.lbt(z).BackColor = &H202020  
End If  
  
    End If  
Next d  
Next n  
screen.MousePointer = 0  
Call ResultsGrf_click  
End Select
```

End Sub

,
,

Sub CrvZoom ()

```
On Error Resume Next  
grafzoom.Cls.  
If ActivePage < 1 Then  
    Call ResultsGrf_click  
    Exit Sub  
End If  
obj = ActiveObj  
zoomarea = 30  
zoomarea2 = zoomarea \ 2  
grafzoom.ScaleWidth = HourPerPage * 60  
grafzoom.ScaleLeft = Seg(ActivePage).Left  
Rec_Start = grafzoom.ScaleLeft + 1
```

**Factory : No. 4 Street Iraqui Street Rajaii. TEHRAN IRAN
Telfax 0098-21-5052836 Po.Bo. 18915-133**

OFFICE : No. 201
Mahestan Bld.
Enghelab Sqr.
TEHRAN IRAN
Tel. 00 98 21 6432854
Fax 00 98 21 6420759



Final Report (Page 24)

```
Rec_end = Rec_Start + grafzoom.ScaleWidth - 1
If Rec_end > UBound(grf, 2) Then Rec_end = UBound(grf, 2)
grafzoom.Cls
grafzoom.DrawMode = 7 ' (7=xor 13=copy)
grafzoom.Line (Rec_Start, 0)-(Rec_end, 0), QBColor(3)
For n = 0 To 1
  For d = 1 To 6
    If curve_Item(n, d) < 50 Then
      z = curve_Item(n, d)
      If Hr.lbt(z).Visible = True Then
        grafzoom.ForeColor = QBColor(curve_color(n, d))
        If Rec_Start < 1 Then Rec_Start = 1
        For rec = Rec_Start To Rec_end - 1
          bol1 = (grf(26, rec) = 789)
          bol2 = (grf(26, rec + 1) = 789)
          If bol1 And bol2 Then
            Y2 = grf(z, rec + 1)
            Y1 = grf(z, rec)
            grafzoom.Line (rec, Y1)-(rec + 1, Y2)
          End If
        Next rec
      Else
        'curve_Item(n, d) = 50
        'hr.lbt(z).ForeColor = QBColor(0)
        'hr.lbt(z).BackColor = &H202020
      End If
    End If
  Next d
Next n
z = Int(zoom(ActivePage).X1)
zoomzoom.X1 = z
zoomzoom.X2 = z
zoomzoom.BorderColor = zoom(ActivePage).BorderColor
Grfzoom_pnl.BackColor = zoomzoom.BorderColor
a$ = Right$("0" & z \ 60, 2) & ":" & Right$("0" & z Mod 60, 2)
RecLb(ActivePage).Caption = a$
Call ResultsGrf_click
```

Factory: No. 4 Street Iraqi Street Rajaii. TEHRAN IRAN
Telfax 0098-21-5052836 Po.Bo. 18915-133

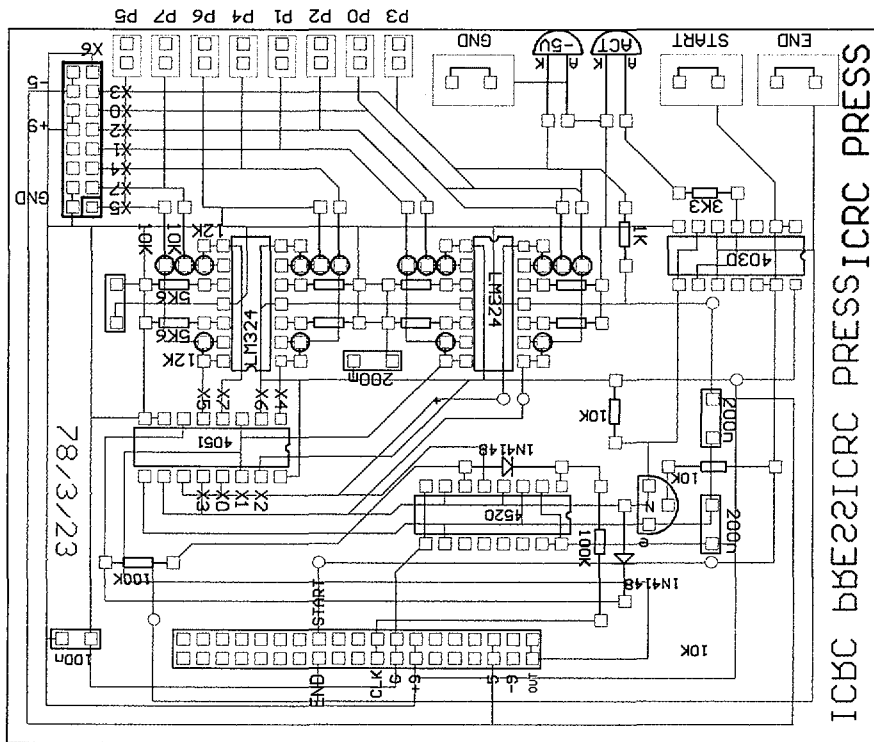

ICBC BBE22ICRC PRESS

78/3/23

P3 P0 P2 P1 P4 P6 P7 P5