



TOGETHER
for a sustainable future

OCCASION

This publication has been made available to the public on the occasion of the 50th anniversary of the United Nations Industrial Development Organisation.



TOGETHER
for a sustainable future

DISCLAIMER

This document has been produced without formal United Nations editing. The designations employed and the presentation of the material in this document do not imply the expression of any opinion whatsoever on the part of the Secretariat of the United Nations Industrial Development Organization (UNIDO) concerning the legal status of any country, territory, city or area or of its authorities, or concerning the delimitation of its frontiers or boundaries, or its economic system or degree of development. Designations such as “developed”, “industrialized” and “developing” are intended for statistical convenience and do not necessarily express a judgment about the stage reached by a particular country or area in the development process. Mention of firm names or commercial products does not constitute an endorsement by UNIDO.

FAIR USE POLICY

Any part of this publication may be quoted and referenced for educational and research purposes without additional permission from UNIDO. However, those who make use of quoting and referencing this publication are requested to follow the Fair Use Policy of giving due credit to UNIDO.

CONTACT

Please contact publications@unido.org for further information concerning UNIDO publications.

For more information about UNIDO, please visit us at www.unido.org

21109

UNIDO
UNITED NATIONS INDUSTRIAL DEVELOPMENT ORGANIZATION

**REPORT OF THE
EXPERT GROUP MEETING ON
IN-USE MOTOR VEHICLE INSPECTION FOR
EMISSION CONTROL IN THE ASIA-PACIFIC REGION**

**organized by UNDP, UNIDO and
Korea Institute of Science and Technology (KIST)**

Seoul, 20-22 October 1992

TABLE OF CONTENTS

I. Introduction	1
II. Agenda	2
III. Participants	2
IV. Presentation of the Consultant's Paper	2
V. Presentation of the Country Papers	11
VI. Review of the draft of "Guidelines" and Adoption of Its Terms	14
VII. Venue of Next Meetings	15
VIII. Conclusions and Recommendations	16
Annex 1 Agenda	18
Annex 2 List of Participants	20
Annex 3 National Focal Points	24
Annex 4 Country Paper of China	26
Annex 5 Country Paper of Hong Kong	41
Annex 6 Country Paper of India	76
Annex 7 Country Paper of Korea	97
Annex 8 Country Paper of Singapore	112
Annex 9 Country Paper of Sri Lanka	125
Annex 10 Country Paper of Thailand	136
Annex 11 Country Paper of Malaysia	149
Annex 12 Country Paper of Philippines	174
Annex 13 Country Paper of Indonesia	193
Annex 14 Country Paper of Iran	233

I. INTRODUCTION

In accordance with Project Document DP/RAS/89/057 "Regional Network on Control and Regulatory Measures Concerning Motor Vehicle Emissions" UNIDO/UNDP in cooperation with Korea Institute of Science and Technology(KIST) organized an Expert Group Meeting on In-Use Motor Vehicle Inspection for Emission Control in the Asia-Pacific Region. The meeting was held on October 20-22, 1992 in Seoul at the premises of KIST.

The meeting was the first in the series of four meetings to be held under the project DP/RAS/89/057. It was devoted to problems of in-use vehicle inspection for emission control to which top priority is given in the first phase of the project.

Main objectives of the Meeting were as follows:

1. Development objective

To initiate, develop and promote the cooperation among the countries of the region in the field of motor vehicle emission control and to set up the nucleus of the regional network for the development and promotion of recommendations concerning exhaust emission standards and practical policy measures.

2. Immediate objectives

- a) to provide a forum for exchange of experience and information among countries of the region in the field of in-use motor vehicle emissions,
- b) to assess options for the inspection of in-use motor vehicles for emission control, in particular test procedures and emission limits, and to identify options and common approaches which are most appropriate for the participating countries,
- c) to review the draft of "Guidelines for In-use Motor Vehicle Inspection for Emission Control in the Asia-Pacific Region" and to adopt its terms.

II. Agenda

The agenda of the meeting is inclosed in Annex 1.

III. Participants

Participants were:

- the representatives of the following countries which have already declared their participation or their interest in the project: China, Hong Kong, India, Indonesia, Iran, Korea, Malaysia, Philippines, Singapore, Sri Lanka and Thailand,
- UNDP/UNIDO staff,
- a technical consultant.

The full list of participants is given in Annex 2. The updated list of the national focal points for the projects is enclosed in Annex 3.

IV. Presentation of the Consultant's Paper

The consultant presented his draft of "Guidelines for In-use Motor Vehicle Inspection for Emission Control in the Asia-Pacific Region", composed of two parts.

The first part included:

- the status of in-use vehicle inspection for emission control around the world,
- the status of in-use vehicle inspection in countries of the region visited during his fact-finding mission: India, Korea, Malaysia, Singapore, Sri Lanka, Thailand,
- a technical background on pollutant emissions from SI engine-driven vehicles and their measurement methods,
- a technical background on smoke measurement of diesel-driven vehicles.

In the second part of his paper, the consultant presented:

- an outline of the motor vehicle emission control system common for

countries participating in the project, comprising general description of the system, functions of its main components, organizational structure of technical services for emission control,

- proposals for common test procedures for in-use vehicles equipped with both SI and diesel engines, including emission limits, measurement methods and required equipment,
- recommendations for implementation of in-use vehicle inspections for emission control.

In the motor vehicle emission control system proposed for countries participating in the project the emission control consists in:

- legislation empowering competent authorities to carry out control and specifying its rules and procedures,
- standards (regulations) for new - and in-use vehicles and standards for fuel quality, specifying limits and test methods,
- network of test centres and inspection stations,
- supportive and enforcement elements such as vehicle registration system, economic measures: e.g. taxation, custom-duties, incentives etc.. enforcing measures: e.g. sanctions and penalties, maintenance and repair network.

Inspections of in-use vehicles for emission control include:

- a) mandatory periodical inspections,
- b) random on-road checks.

There should be a good cooperation between services conducting periodical inspections on one hand and random on-road checks on the other. These services often report to different authorities. They, in particular, should:

- use the same test methods,
- use the same "passed" and "failed" criteria,
- exchange informations.

On-road check results should be used to monitor the performance of

individual inspection stations. Stations for which the failure rate during these checks is high are to come under special surveillance. Their equipment is to be checked for malfunctions and calibration. Penalties should be introduced for violation.

In principle, in a long term the periodic inspection should be mandatory for all vehicle categories. The exception to this rule can only be categories whose contributions to air pollution is marginal e.g. mopeds, motorcycles in some countries. As the frequency of periodical inspection depends on many variables different for countries participating in the project, general recommendations in this respect can not be given. It should be determined to some extent by the method of "trial's and errors", cost effectiveness being, among others, a factor. One of the criteria for the efficiency of periodical inspection is the discrepancy between its failure rate and that of on-road checks. A high discrepancy shows that this efficiency, among others because of insufficient frequency, is too low.

It is recommended that the periodical inspection is conducted on "test only" basis. Any repairs should not be performed by inspection stations. The only exception to this rule is the CO adjustment for uncontrolled-and reduced-emission vehicles if the limit is exceeded.

The annual share of vehicles checked during on-road checks should be at least 5% of total number. If this share is lower, the efficiency of the emission reduction suffers. Two kinds of limits are recommended:

- basic limits,
- "prohibition" limits.

The vehicle which fails the periodical inspection, among others because it exceeds the basic limit, is given a repair order. The owner is obliged to have the defects repaired and to submit the vehicle for reinspection within the specified period, usually a fortnight. If the vehicle fails the reinspection it is given a "prohibition of use" order. Such an order is also issued if the emission during the periodical inspection exceeds the "prohibition" limit. In this case it is only permitted to drive the

vehicle the shortest way to a repair station and back to the inspection station.

If the vehicle fails a road-side check, its inspection certificate is cancelled. It should be submitted for inspection within the prescribed period. If the emission level exceeds:

- basic limit for diesel vehicles,
- "prohibition" limit for vehicles equipped with SI engines, the driver/owner is fined. They are also fined when:
 - the vehicle is submitted for inspection (after road-side checks) or for reinspection (if it has failed the periodical inspection) after the prescribed date,
 - full load stop screw sealing is removed (in diesel vehicles).

The basic and "fine" limits for smoke are the same as in this case the owner/driver is able to see that the vehicle is in poor technical conditions. However, it is recommended to set the "fine" limit at "prohibition" limit for vehicles equipped with SI engines.

Countries participating in the project differ very much in respect of conditions affecting the emission level. Consequently, the implementation of one common emission standard for in-use vehicle in the initial phase of the project does not seem to be realistic. Therefore three levels of requirements are recommended:

- for uncontrolled vehicles,
- for reduced-emission vehicles,
- for low-emission vehicles.

The ultimate goal is, however, to harmonize requirements and to introduce common standards at least for groups of countries having similar conditions.

The following scope of in-use vehicle inspections and limits were proposed for vehicles equipped with SI engines.

Uncontrolled vehicles

A. Visual checks:

- exhaust system,
- inlet system,
- ignition system,
- oil and fuel leaks.

B. Check of carbon monoxide (CO) concentration at (low) idle speed.

Basic limit: 4.5% vol. (6% vol.),

Prohibition limit: 8% vol.

If the CO concentration at idle exceeds 4.5% vol., the idle adjustment should be performed by means of the components provided for this purpose and specified in the owner's manual. If the idle can not be adjusted properly, the vehicle is given a repair order (see point 5.2.4.). However, if the engine operation below 4.5% vol. is not smooth (vibrations, stalling, speed fluctuations) with the mixture needle not fully turned in and visual checks have not detected any defects, the vehicle is given the "grace" limit 6.0% vol.

Reduced-emission vehicles

A. Visual checks:

- exhaust system,
- inlet system,
- ignition system,
- oil and fuel leaks.
- crankcase ventilation system,
- anti-pollution devices.

B. Check of CO concentration at idle speed

Basic limit: 4.5% vol. within the engine idle speed range specified by the manufacturer and approved during the type certification.
Prohibition limit: 8.0% vol.

If the measured CO value exceeds 4.5% vol. or the engine idle speed is not within specified range, the idle adjustment should be performed by means of components provided for this purpose and specified in the owner's manual. If the idle can not be adjusted properly, the vehicle is given a repair order (see point 5.2.4.).

Low-emission vehicles

A. Visual checks:

- exhaust system,
- inlet system,
- ignition system,
- crankcase ventilation system,
- anti-pollution devices, in particular catalytic converter and λ - probe.

B. Checks of pollutant concentrations

Two steps of requirements for low-emission vehicles are set:

- step I - basic requirements,
- step II - enhanced requirements.

The details are given in Table 1. For low-emission vehicles any idle adjustments are not performed. If the vehicle fails to meet any requirements, a repair order is given.

Requirements for low-emission vehicles

Table 1

Specification	Step I	Step II
1. CO concentration at low idle* (% vol.):		
- basic limit	1.2	0.5
- prohibition limit	4.5	4.5
2. HC concentration at low idle* (ppm as hexane):		
- basic limit	220	100
- prohibition limit	800	800
3. CO concentration at raised idle speed 2500 rpm (% vol.):		
- basic limit	---	0.3
- prohibition limit	---	4.5
4. HC concentration at raised idle speed of 2500 rpm		
- basic limit	---	100
- prohibition limit	---	800
5. Air fuel equivalence ratio at raised idle speed of 2500 rpm	---	1 + 0.03

* Low idle speed should be within the range specified by the manufacturer and approved during type certification.

The proposed scope of emission inspections and limits for vehicle equipped with Diesel engines are as follows.

A. Visual checks:

- exhaust system,
- injection system,
- inlet system,
- oil and fuel leaks.

- anti-pollution devices.

B. Check of smoke intensity by free acceleration method from low idle speed.

Uncontrolled vehicles

Basic limit: - 65HSU (2.3m^{-1})

Prohibition limit: - 80HSU (3.7m^{-1})

Reduced-emission vehicles

Basic limit: - 50HSU (1.6m^{-1})

Prohibition limit: - 80HSU (3.7m^{-1})

Low-emission vehicles

Basic limit: value measured and approved during the type certification increased by a lump figure of 10HSU (0.4m^{-1}) but not higher than 1.6m^{-1} (50HSU)

Prohibition limit: - 80HSU (3.7m^{-1})

The above limits are expressed in HSU. However, it does not mean that only Cartridge smokeometers can be used. Other types, including filter-type instruments, can be applied providing the limits are equivalent to those specified above.

In periodical inspections, the full-load stop adjustment screw of the injection pump governor is sealed after the vehicle has passed the test. The sealing makes it difficult to decrease the fuel delivery before the inspection and to increase it, and therefore the smoke level, after the

inspection which is sometimes the case. If any repair of the injection pump requiring the removal of sealing is performed between two consecutive inspections, the vehicle must be taken to an inspection station, immediately after the repair has been completed, for a smoke check and sealing. Vehicles can not be used without the screw properly sealed.

The consultant recommended the following equipment for checks of pollutant concentrations for mandatory periodical inspections and random on-road inspections:

- a) for vehicles equipped with SI engines:
 - mono-component(CO) analysers for uncontrolled and reduced-emission vehicles,
 - bi(CO,HC)- and multi-component analysers (CO, HC, CO₂, O₂) for low-emission engines,
- b) for vehicles equipped with Diesel engines:
 - partial flow opacimeters.

The main conclusions of consultant's paper were as follows:

1. The situation in the region with regard to in-use vehicle technical conditions and their inspections varies from country to country. In the majority of countries participating in the project the potential of in-use vehicle inspections with regard to emission reduction is not taken sufficient advantage of.
2. It is possible to considerably reduce emissions from motor vehicles by:
 - upgrading the standard of current inspections,
 - extending the inspection on further vehicle categories significantly contributing to total air pollution.There is a need for the introduction of such enhanced inspections in the majority of countries participating in the project.
3. The reduction of emission through enhanced inspections can be achieved with lower costs of initial investment than other reduction options. On the average, it may be in many cases cost-neutral to

motorists as additional costs of inspections and repairs are compensated by lower fuel costs resulting from an improvement in vehicle fuel economy.

4. In order to upgrade the technical standard of current inspections the following main steps should be taken up:

- to specify in detail and/or to correct test methods,
- to enforce inspection stations to conduct test according to specifications through trainings of inspectors, supervision and sanctions,
- to introduce checks and certification of test equipment.

In the first place this upgrading should apply to smoke measurements in diesel vehicles.

5. One or two centres for training of senior technical inspectors from countries participating in the project are badly needed in the region. The region as a whole has sufficient expertise and facilities for this purpose.

6. A reliable data base for the assessment of motor vehicle emission reduction options and for the identification of the most suitable ones is required. For this purpose, motor vehicle emission inventories under actual conditions should be established for individual countries and for the region as a whole.

The consultant's paper is not enclosed to this Report as it was distributed to all participating countries in August, 1992.

V. Presentation of the Country Papers

The country papers were presented by the country representatives. They are listed below in the order in which they were presented, all papers being enclosed as Annexes.

China (Annex 4)

Title: General View of Motor Vehicle Inspection for Emission Control in

China

Authors: Mr. Piao Zhongxuan, Mr. Li Guoxiang and Mr. Ye Huihai,

Highway Research Institute, Ministry of Communications.

Presented by: Mr. Ye Huihai.

Hong Kong (Annex 5)

Title: Vehicle Emission Control in Hong Kong

Presented by: Mr. Kong Ha

Vehicle Emission Control Section, Hong Kong Environmental
Protection Department.

India (Annex 6)

Title: Country Paper on Inspection of In-Use Motor Vehicle Emissions in
India

Authors: Dr. B. P. Pundir, Mr. N. Bagchi, Mr. B. Sengupta

Presented by: Mr. N. Bagchi.

Korea (Annex 7)

Title: Vehicle Emission Standard and Control Strategies in Korea

Author: Dr. Kil-Choo Moon

Environment Research Center, Korea Institute of Science and
Technology (KIST)

Presented by: Dr. Kil-Choo Moon.

Singapore (Annex 8)

Title: Country Paper of Singapore

Presented by: Mr. Ng Yook Koong

Registry of Vehicles.

Sri Lanka (Annex 9)

Title: Country Paper of Sri Lanka

Presented by: Mr.D.D.T.Wijesundara

Commissioner of Motor Traffic.

Thailand (Annex 10)

Title: In-use Motor Vehicle Inspection for Emissions Control in Thailand.

Authors: Mr.Preecha Orprasirth,

Deputy Director General, Land Transport Department,

Mr.Suvidh Voravisuthikul,

Director of Transport Engineering Division, Land Transport

Department

Presented by: Mr.Preecha Orprasith.

Malaysia (Annex 11)

**Title: Country Report of Malaysia. Control and Regulatory Measures
Concerning Motor Vehicle Emissions**

Authors: Mr.Marzuki Mokhtar

Environmental Control Officer, Mobile Sources Section,

Department of Environment

Mr.Yacob ismail

Assistant Director, Technical Division, Road Transport Division.

Presented by: Mr.Marzuki Mokhtar.

Philippines (Annex 12)

**Title: Status of In-use Motor Vehicle Inspection for Emission Control in
the Philippines**

Authors: Mrs.Cirila S.Botor, Att.Percival Cendana, Mr.Emanuel

Gutierrez

Presented by: Mrs. Cirila S. Botor.

Indonesia (Annex 13)

Title: Country Paper of Indonesia

Author: Mr. Dwi Wahyono Syahudi

Directorate General of Land Transport, Ministry of Communications

Presented by: Mr. Dwi Wahyono Syahudi.

Iran (Annex 14)

Title: Motor Vehicle Pollution in Iran

Author: Mrs. Paimaneh Hasteh

Teheran Traffic Control Centre

Presented by: Mrs. Paimaneh Hasteh.

VI. Review of the Draft of "Guidelines" and Adoption of Its Terms.

The Meeting reviewed in great detail the draft of "Guidelines for In-use Motor Vehicle Inspection for Emission Control in the Asia-Pacific Region" prepared by the consultant. The main proposals for amendments made and accepted were as follows.

- 1) Amendments with regard to the form and content of the draft:
 - a) to include findings of the consultant's mission to China, Hong Kong, Philippines, Indonesia and Iran to be held after the Meeting into Annex 1,
 - b) to consider the possibility of combining chapters 4.4 and 7,
 - c) to prepare "Executive Summary" and to include chapter 7 "Conclusions" into it.
- 2) Amendments with regard to the motor vehicle emission control system:
 - a) certificate of fitness of the equipment used for emission inspections

should be issued not by technical centers or by regional inspection stations, but by an independent authority.

3) Amendments with regard to emission limits:

a) to set up the basic smoke limit for low-emission vehicles equipped with Diesel engines at 40 HSU instead of at 50 HSU as recommended in the draft, because particulates and smoke emissions are a very important environmental problem in the whole region,

b) to reduce the "prohibition" limits:

- for reduced-emission vehicles equipped with Diesel engines from 80 HSU to 70 HSU,

- for low-emission vehicles equipped with Diesel engines from 80 HSU to 60 HSU,

- for low-emission vehicles equipped with SI engines (step II) from 4.5% vol. to 3% vol.,

c) to introduce two steps of requirements for reduced-emission vehicles equipped with SI engines:

- step I: CO limit 4.5% vol. (as recommended in the draft),

- step II: CO limit 4.5% vol., HC limit 1000ppm (NDIR analyser expressed as hexane),

4) Amendments with regard to test methods:

a) to specify "at least" four accelerations for the measurement of smoke level at free acceleration from low idle: at least 2 for cleaning the exhaust system and combustion chamber and 2 for actual measurement.

The Meeting adopted the amended terms of "Guidelines" with regard to:

a) motor vehicle emission control system,

b) inspection procedure,

c) test methods,

d) emission limits,

e) equipment.

VII. Venue of Next Meetings

The next workshops will be devoted to:

- 1) new motor vehicle type approval procedures with regard to emissions,
- 2) motor fuel and lubricant specifications for low emissions,
- 3) practical policy measures for the reduction of vehicle emissions.

In order to strengthen the activities and cooperation under the project and to extend the exchange of experience, the Meeting recommended to organize the workshop listed under 1) in a country where testing facilities for type approval exist and the workshop 2) in an oil producing country with well-developed petrochemical industry. The Meeting suggested that the workshop 1) be hosted by Indonesia and the workshop 2) by Singapore. The national focal points of these two countries and also other interested countries are requested to inform UNIDO by the end of December about their readiness to host the workshops.

VIII. Conclusions and Recommendations

1. The gradual harmonization of inspection procedures for in-use motor vehicle emission control is required in the region, with a view to introducing, as the ultimate goal, common test methods, equipment and emission limits at least for groups of countries having similar conditions. The harmonization will assist in the reduction of motor vehicle emissions, among others, by increasing the market power and volume and by making it easier for vehicle suppliers to meet common standards specific for the region.
2. It is recommended to phase in the harmonization in lines with the amended terms concerning control system, inspection procedures, test methods, equipment and emission limits specified in "Guidelines for In-use Motor Vehicle Inspection for Emission Control in the Asia-Pacific Region" adopted at the Meeting.
3. In the majority of countries participating in the project the potential of in-use vehicle inspections with regard to emission reduction is not taken sufficient advantage of. It is possible to considerably reduce

emissions by upgrading the standard of current inspections. This reduction can be achieved with lower costs of initial investments than other reduction options. On the average, it is also cost-neutral for vehicle owners. The detailed recommendations given in "Guidelines" for measures to be taken in individual countries are very useful for this purpose.

4. In order to harmonize inspection procedures and to upgrade the standard of current inspections for in-use motor vehicle emission control a centre for training of senior technical men in charge of motor vehicle emission problems in countries participating in the project is needed in the region. The main focal point for the project is expected to play an active role in the training.

AGENDA

of Expert Group Meeting
on In-Use Motor Vehicle Inspection
in the Asia-Pacific Region

20 October 1992, Tuesday

- 9:00 - 9:30 Registration at KIST
- 9:30 - 10:20 a) Opening Remarks by Mr. Jacob Guijt,
 UNDP Resident Representative
 b) Welcome Address by Vice-president of KIST, Dr. Oh-kwan,
 kweon
 c) Welcome Address and Project Objective Description
 by Dr. Hans Seidel, UNIDO Senior Industrial Development
 Officer
- 10:30 - 12:00 Presentation of the draft guidelines by UNIDO
 Consultant, Dr. S. Radzimirski
 Part I: Status of the In-Use Vehicle Inspection for
 Emission Control
- 14:00 - 15:30 Presentation of the draft guidelines by UNIDO
 Consultant, Dr. S. Radzimirski
 Part II: In-Use Vehicle Emission Inspection System
 for the Region
- 15:45 - 16:15 Country Paper of China
- 16:15 - 16:45 Country Paper of Hong Kong
- 16:45 - 17:15 Country Paper of India
- 17:15 - 17:45 Country Paper of Korea

21 October 1992, Wednesday

9:00 - 9:30 Country Paper of Singapore

9:30 - 10:00 Country Paper of Sri Lanka

10:00 - 10:30 Country Paper of Thailand

10:45 - 11:15 Country Paper of Malaysia

11:15 - 11:45 Country Paper of Philippines

11:45 - 12:15 Country Paper of Indonesia

12:15 - 12:45 Country Paper of Iran

14:15 - 18:00 Review of the draft of "Guidelines" and
adoption of its terms.

22 October 1992, Thursday

9:00 - 12:00 a) Review of the draft final report of
the meeting and its adoption
b) Venue of next Expert Group Meetings
c) Discussion on common problems, prospects and ideas for
additional activities.
d) Closing remarks by UNIDO representative, Dr. Hans Seidel

14:00 - 18:00 Technical Visit to North Inspection Station in Seoul.

LIST OF PARTICIPANTS
DF/RAS/89/057 Expert Group Meeting on
In-use Motor Vehicle Inspection for Emission
Control in the Asia-Pacific Region
Seoul, Rep. of Korea, 20-22 October 1992

- China
- (1) Mr. Piao Zhongxuan
Highway Research Institute
48 Bei San Huan Zhong Rd.
Beijing 100088, P.R. China
 - (2) Mr. Li Guoxiang
Highway Research Institute
48 Bei San Huan Zhong Rd.
Beijing 10008, P.R. China
 - (3) Mr. Ye Huihai
Highway Research Institute
48 Bei San Huan Zhong Rd.
Beijing 100088, P.R. China
- Hong Kong
- (4) Mr. Raymond P.M. Leung
Principal Environmental Protection Officer
Environmental Protection Department
Group Head, Air Service Group
28th Floor, Couthorn Centre
130 Hennessy Rd.
wan Chai, Hong Kong
Fax : 827 8040
Tel : 594 6414
 - (5) Mr. Kong Ka
Sen. Environmental Protection Officer
Vehicle Emission Control Section
28th Floor, Conthorn Centre
130 Hennessy Rd.
Wan Chai, Hong Kong
Fax : 827 8040
Tel : 594 6414
 - (6) Mr. Yat-shing Yam
Environmental Protection Officer
Vehicle Emission Control Section
28th Floor, Couthorn Centre
130 Hennessy Rd.
Wan Chai, Hong Kong
Fax : 827 8040
Tel : 594 6414

-
- India (7) Mr. N. Bagchi
Director
Ministry of Environment and Forest
703 Paryavaran Bhavan
C.G.O. Complex, "B" Block, Lodhi Road
New Delhi - 110 003
Tel : (9111) 362 663
- (8) Mr. B Sengupta
Central Pollution Control Board
c/o UNDP New Delhi
- (9) Mr. P. Pundir
Indian Institute of Petroleum
c/o UNDP New Delhi
- Indonesia (10) Mr. Dwi Wahyono Syamhudi
Subdirector for Vehicle Safety and Environment
Directorate General of Land Transport
Ministry of Communications
Directorate Llajr
JL Taman Fatahillah No.3
Jakarta Kota
Tel : (62-21) 677746
- Iran (11) Mrs. Piaman Haszeh,
Tehran Municipality
- Malaysia (12) Mr. Marzuki Mokhtar
Environmental Control Officer
Dept. of Environment
Ministry of Science, Technology and Environment
12th + 13th Floor, Wisma Sime Darby
Jalan Raja Laut
50662 Kuala Lumpur
Fax : 603-293 6006
Telex : Mostec Ma 28154
Tel : 293 8955
- (13) Mr. Yacob bin Ismail
Technical Director
Road Transport Department
Ministry of Science, Technology and Environment
12th + 13th Floor, Wisma Sime Darby
Jalan Raja Laut
50662 Kuala Lumpur
Fax : 603-293 6006
Telex : Mostec Ma 28154
Tel : 293 8955

-
-
- Philippines (14) Mr. Percival Acosta Cendana
Land Transportation Office
Dept. of Transportation and Communications
c/o UNDP Manila
- (15) Mrs. Cirila Botor
Bureau of Product Standards
Dept. of Trade and Industry
c/o UNDP Manila
- (16) Emmanuel Gutierrez
Supervising Environmental Management Specialist
National Capital Region, DENR
c/o UNDP Manila
- Singapore (17) Mr. Tan Wee Hock
Executive Engineer
Pollution Control Department
- (18) Mr. Ng Yook Koong
Head, Vehicle Engineering Division
Registry of Vehicles
- Sri Lanka (19) Mr. D.D.J. Wijesundera
Commissioner of Motor Traffic
Ministry of Transport and Highways
- Thailand (20) Mr. Preecha Orprasirith
Deputy Director-General (Technical)
Department of Land Transport
Ministry of Transport and Communication
c/o UNDP
Bangkok
- (21) Mr. Suvidh Voravisuthikul
Director of Transport
Department of Land Transport
Ministry of Transport and Communication
c/o UNDP
Bangkok
- UNIDO Mr. Hans Seidel
Senior Industry Development Officer
- Dr. S. Radzimirski, Consultant

Rep. of Korea

Won Hoon Park
Environment Research Center Korea Institute of Science and
Technology P.O.Box 131, Cheongryang KOREA
Tel : 962-8801 Ext. 4642
Fax : 969-0230

Kyu Hong Ahn
Environment Research Center Korea Institute of Science and
Technology P.O.Box 131, Cheongryang KOREA
Tel : 962-8801 Ext. 4642
Fax : 969-0230

Kil-Choo(K.C.) Moon
Environment Research Center Korea Institute of Science and
Technology P.O.Box 131, Cheongryang KOREA
Tel : 962-8801 Ext. 4642
Fax : 969-0230

Kang-Lae Cho
Environmental Protection Institute
280-17 Bulkwang-Dong Eunpyeong-Gu, Seoul KOREA

Myoung-Do Eom
National Institute of Environmental Research
Motor Vehicle Emission Research Laboratory

Chang-Beom Ahn
Planning Department, Hyundai Motors
140-20 Kye-Dong Chongro-Gu, Seoul

Dong-Soo Kim
The central research laboratory, Kia Motors
781-1 Soha-Dong Kwangmyeong City Kyeonggi-Do

Kiwon Ko
Daewoo Motors
199 Cheongchem-Dong Buk-Gu, Incheon

Seung-Yong Hong
The management Section, Asia Motors
406-28 Mok1-Dong Yangcheon-Gu, Seoul

Soo-Seob Choe
SSangyong Motors, 448-2 Togok2-Dong Kangnam-Gu Seoul
The Department of Certificatory technical authentication
technology

Kiwung Baek
Hyundai Motors Co.
140-2 Kye-Dong Changro-Gu, Seoul

Seongwon Lee

Weon-Guk Kang

Moon-Soo Ahn
Songpa-Gu,
Ministry of Environment

NATIONAL FOCAL POINTS

- CHINA
 Mr. Piao Hehong & Mr. Piao Zhonguan
 Deputy Director
 Highway Research Institute
 Ministry of Communications
 48 Bei San Huan Zhong Road
 Beijing 100068
 Tel : 201 3399(Ext. 2903)
 Fax: 201 4130
- HONG KONG
 Mr. Kong Ha
 Senior Environmental Protection Officer
 Vehicle Emission Control Section
 Environmental Protection Department
 Air Services Group
 33/F., Wanchai Tower 3
 5 Gloucester Road
 Wanchai, Hong Kong
 Tel : (852)594 6414
 Fax: (852)827 8040
- INDIA
 Mr. N. Bagchi
 Director
 Ministry of Environment and Forest
 703 Paryavaran Bhavan
 C. G. O. Complex, "B"Block, Lodhi Road
 New Delhi - 110 003
 Tel : (9111) 436 2663
 Fax: (9111) 436 0678
- INDONESIA
 Mr. Dwi Wahyono Syamhudi
 Deputy Director for Motor Vehicles Technology
 and Road Worthiness
 Directorate General of Land Transport
 Jl. Jend. Sudirman 77 - Jakarta Selatan
 Indonesia 12190
 Tel : (62-21) 5706674, 5225007
 Fax: (62-21) 5706624
 Telex: 44723 DJPD IA
- KOREA
 Mr. Kyu-Hong Ahn
 Environment Research Center
 Korea Institute of Science and Technology
 39-1 Hawolgok-Dong, Sungbuk-Gu
 Seoul 136 - 791
 Tel : (822) 962 8801 Ext. 4642
 Fax: (822) 969 0230
 Telex: KISTROK K27380

MALAYSIA Mr. Tan Meng Leng
Dept. Director General (Operation)
Dept. of Environment
Ministry of Science, Technology and Environment
13th Floor, Wisma Sime Darby
Jalan Raja Laut
50662 Kuala Lumpur, Malaysia
Tel : (603) 2938955
Fax: (603) 2931480

PHILIPPINES Mr. Percival A. Cendana
Head Executive Assistant, Office of the Assistant Secretary
Vice - Chairman, LTO Task Force on Legal Affairs
Dept. of Transportation and Communication
East Avenue
Quezon City
Tel : (632) 921 9071
Fax: (632) 921 9072

SINGAPORE Mr. NG Yook Koong
Head
Vehicle Engineering Division
Sin Ming Drive
Singapore 2057
Tel : 4509260
Fax: 4522661

SRI LANKA Mr. D. D. J. Wijesundara
Commissioner of Motor Traffic
Dept. of Motor Traffic
Elvitigala Mawatha
Colombo 05
Tel : (941) 698 717
Fax: (941) 694 547

THAILAND Mr. Suvidh Voravisuthikul
Director
Transport Engineering Division
Land Transport Department
Phaholyothin Rd. Bangkok
Bangkok 10900
Tel : (662) 271 3053
Fax: (662) 271 3037

**General View of Motor Vehicle Inspection
for Emission Control in China**

**Piao Zhongxuan, Li Guoxiang and Ye Huihai
Highway Research Institute
The Ministry of Communications**

Beijing, China

September 1992

General View of Motor Vehicle Inspection for Emission Control in China

I. Current situation of in-use motor vehicle inspection for emission control

In pace with the rapid growth of economic development in China, motor vehicles of all kinds are increasing all over the country. However, most of them are running in medium and large cities, for instance, there are some 600 thousand of motor vehicles in Beijing accounting for 1/10 of the total. Therefore, emphasis of motor vehicle inspection for emission control is naturally laid upon medium and large cities.

The Government attaches grave importance to environmental air quality control. At present, an air quality monitoring and detecting network at all levels has been set up, under unified planning, by the competent environment protection authority. Meanwhile, carbon mono-oxide (CO), nitrogen oxides (NO_x) monitoring and detecting posts are assigned in some traffic lines, and particularly in arteries such as those in the Beijing urban districts and such posts have come up to 30 in number to seek air pollution control. It is informed that, in the period of 1986-1990, the mean environmental NO_x and CO concentrations of the Capital area are both up to the corresponding national standards. The municipal government has adopted measures of restraining the urban-district-oriented traffic facilities and establishing a purificating system in order to alleviate the congestion and to decrease the pollution emissions.

Motor vehicle inspection for emission control should be strictly undertaken by all motor vehicle manufacturers, refitting works, users, maintenance and repair stations and importers to comply with the emission regulation stipulated in the relevant national legislation. The Ministry of Communications (M. O. C) and the Ministry of Public Security (M. P. S) will jointly carry out periodic check-out and supervision works over running and overhauled motor vehicles. In-use motor vehicle inspection for emission control are carried out by the motor-vehicle-performance-inspection stations and competent maintenance and repair workshops which have been formally authorized by the governmental department in charge.

At the moment, there are over 300 motor-vehicle-performance-inspection stations of all kinds in the country, and half of them are belong to M. O. C. Motor-vehicle-performance-inspection stations should at least undergo such safety and environment tests upon vehicles once a year to enforce a faithful compliance with the corresponding national standards and to issue and withdraw a motor or business licence accordingly.

'Regulations for technical control on motor vehicles' issued by the Ministry of Communications stipulates corresponding clauses for in-use motor vehicle inspection for emission control and emphasizes a mandatory maintenance and repair system of periodic inspection, enforced maintenance and careful repair for in-use motor vehicles. China is now applying a two-class maintenance system which consists of the first and the second. The first class maintenance mainly performs operations on fastening and lubricating and the effective running period is generally between 1,800-2,200 km while the second class maintenance lays stress upon check and adjustment and the running period can last between 13,000-15,000 km. On completion of the second class detection courses, measurements of the exhaust gas up to the present legal standards must also be ascertained.

Together with second-class maintenance and tests made by repairer, mainly with appropriate checking and adjusting processes, the motor owners must make their motor vehicles 2-4 times of inspection against exhaust gas per year to keep them under the national threshold.

At the moment, medium and large scale road transportation corporations in China are generally provided with inspection facilities for exhaust emission control. The Government requires those not having such facilities to adopt most vigorous steps for meeting the demand as soon as possible and will resort to harsher measures to those who fail to implement the above-mentioned requirements on a deadline, or their business should be suspended by order.

As for quality checking on completed products of overhaul works (or on overhauled engine assemblies only), the Government has stipulated compulsory inspection on exhaust emission for a long time. Now, the overhaul life of domestic motor vehicles generally last for about 150,000 km, implying that a normally operated motor vehicle can run for 3-4 years before its next overhaul. Exhaust emission test is a significant item on the list of product conformity and exhaust should carefully be measured and then adjusted with precision instruments until the national threshold of the emission is attained, or no product is allowed to leave workshop.

In addition to the annual testing at standing inspection stations of supervised by public security authorities, on-the-road random checks are also carried out by inspection team authorized by public security department and environment protection department. Drivers found to run a motor whose exhaust emission level beyond limits should be fined and ordered to get over the problem within a definite time.

As above mentioned, the motor vehicle users and the administrative departments attach major importance to in-use motor vehicle inspection for emission control, which, as a result, has contributed to a progressive exhaust emission control so far.

II. Institutional structure of motor-vehicle emission control

In order to conduct supervision and control over motor vehicle emissions, the National Environment Protection Bureau (NEPA), China Motor Industry Corporation (C. M. I. C.), the Ministry of Communications (M. C.), the National Import & Export Commodity Inspection Bureau (NIECIB) and the Ministry of Public Security (M. P. S.) have jointly released a document in which the working scheme and mutual relations are demonstrated as follows:

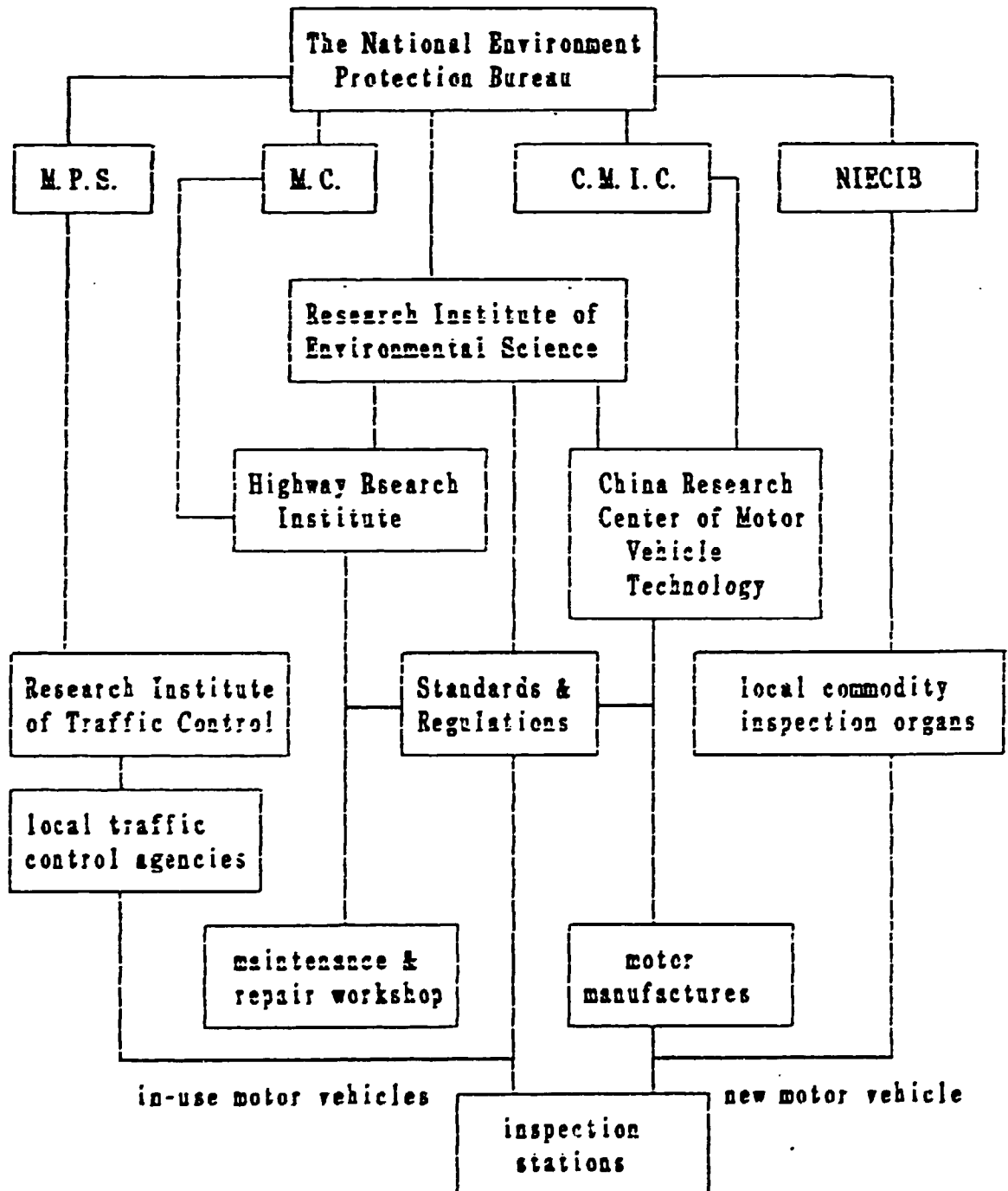

(1) The National Environment Protection Bureau (NEPB)

The National Environment Protection Bureau entrusts China Research Center of Motor Vehicle Technology and Highway Research Institute to draw up the emission standards and the inspection procedure on the basis of the relevant air-quality standards and the air pollution control regulations. The bureau is in charge of approving and publishing those standards and responsible for the supervision and implementation activities.

(2) China Motor Industry Corporation (C.M.I.C.)

Various motor vehicle research institutes under China Motor Industry Corporation undertake the studying programs on reducing the emission level of motor vehicles and the preparation of the related emission control standards and the alike standards and regulations for the motor industry, particularly for the newly manufactured motor-vehicles.

(3) The Ministry of Communications (M.C)

Highway Research Institute under the Ministry of Communications is responsible for research works on technical measures for the emission control and takes over the charge assigned by NEPB to draw up the related standards, regulations and inspection processes. In addition, the institute also assumes the responsibility of developing various detecting methods, devices and equipments during maintenance and repair, mainly for the purpose of the emission control of in-use motor vehicles.

(4) The Ministry of Public Security (M.P.S.)

Traffic control department of the Ministry of Public Security is in charge of traffic safety which means sufficient enforcement of the relevant laws and regulations. A newly manufactured motor vehicle must be subject to the check-out before the registration and licensure for being assured that it is a product of a legal manufacturer and sold by a legal sale-agency. In-use motor vehicle must be subject to a course of annual inspection at any of the traffic control agency authorized inspection stations. Unqualified motors have to be adjusted or repaired until the requirements are conformed in a subsequent inspection.

Carbon mono-oxide and hydrocarbons emissions of motor-vehicles equipped with SI engine should be measured at idling and smoke intensity of diesel powered vehicles should be measured at free acceleration.

In the light of 'Administrative regulations for motor vehicle exhaust control', the environment protection administrative sections of the Government at all levels are bodies obligated to enforce unified supervision on motor exhaust emission control and to instruct and coordinate works of the emission control branches.

The environmental protection administrative sections of the Government at levels of province, autonomy and municipality directly

under the central Government and cities under the jurisdiction of provincial Government should enforce motor exhaust emission control over motor vehicles and the engine assemblies produced by in their districts respectively. Traffic departments of public security organs under the Government at all levels should map out and implement concrete controlling regulations governing in-use motor vehicle exhaust emission. The national import & export commodity inspection organs and their branches bear the responsibility of enforcing the special controlling regulations over motor exhaust of the import products. Administrative departments of military motor vehicles should carry out the special controlling regulations over the exhaust emissions from military motors in accordance with the national environmental protection law.

III. Emission control standards for in-use motor vehicles

In August 1990, the National Environment Protection Bureau presided over a conference with working groups on preparation and revision of the comprehensive emission standards of motor-vehicles/motorcycles. At the moment, the to-be-examined manuscript of the first revised standards of 'The exhaust emission limits on idling conditions and measuring method for gasoline motor vehicle/motorcycle' and 'The exhaust emission limits and measuring methods for gasoline motor vehicles above 3.5T on 9-modes cycle test' have all been reported to the leadership for examination and approval. In addition, the conference decided to set up a nation-wide system of the emission control standards and regulations, to draw up diesel emission control standards and the standards for inspection, the limits of gasoline motor vehicle evaporative emissions and the standards of lead-free fuels.

The 'First revised standards of gasoline motor-vehicle exhaust emissions on idling conditions' set by the China national standard GB3842-83 lists respective allowable limits in the attached table 1. (papers of the solicited opinions and ideas have not been published) and the allowable limits of the original standards GB3842-83 are shown in attached table 2.

IV. Inspection methods and instruments

Beside the standards of the emission control and the inspection methods and processes, technical specifications for the inspection instruments have been laid down accordingly to assure the measurement accuracy, such as, 'Technical specifications for carbon monoxide and hydrocarbons analyzers of gasoline motor vehicle exhaust emission on idling condition' and 'Technical specifications for diesel smoke intensity detectors'.

Briefs of usual inspection instruments for motor emissions at present in China are given in attached table 3.

The oxygen analyzer indicates the oxygen content of exhaust, with which the operator can indirectly determine whether the CO and HC emissions have come up to relevant national standards and the carburetor can be adjusted to the optimized state as to achieve economical running and dynamic performance of a motor vehicle. Moreover, engine failures can there by diagnosed as well. The inspection procedure is briefed as follows:

1) Inspection and adjustment of exhaust emissions at idling

Run an engine at idling speed and preheat it to the designed operational temperature (70-80°C).

Measure the oxygen content of exhaust with the analyzer. The oxygen content should be kept within 8-15% at idling. The CO and HC concentration can be held around <8% and <3000ppm respectively. In case the oxygen content is <8%, the gas mixture should be too dense to conform with the national CO, HC emission limit and the adjustable stop screw of the carburetor should then be adjusted as to restore idling stability of the engine and to keep the oxygen content within 8-15% as stipulated.

The oxygen content within the range of 4-6.3% indicates the carburetor has been adjusted properly and the economic and dynamic performances have been achieved. If the range is exceeded, the liquid level of the carburetor and the carburetor balance should be readjusted up to the specified oxygen limit.

V. Motor vehicle fuels and two-stroke engine oil

1. General gasoline

- (1) The research octane numbers fall into 3 grades, No. 90, No 93 and No. 97.
- (2) The anti-knock index is one half the sum of the RON and MON (The research octane number and motor octane numbers).
- (3) The specification can be seen in attached table 4.

2. Lead-free gasoline

The specifications can be seen in attached table 6.

3. Light diesel fuel

- (1) The fuel only applies to high speed diesel engines in full-load operation where the running speed exceeds 16 r/sec..
- (2) The specifications can be seen in attached table 6.
- (3) •Light diesel fuel No.10 applies to high speed diesel engines equipped with a preheater.
 - Light diesel fuel No.0 applies to vehicles operated in districts where the lowest ambient temperature is above 4°C and the risk rate is 10%.
 - Light diesel fuel No.-10 applies to vehicles operated in districts where the and the lowest ambient temperature is above -5°C and the risk rate is 10%.

- Light diesel fuel No. -20 applies to vehicles operated in districts where the lowest ambient temperature is between 5°C -14°C and the risk rate is 10%.
- Light diesel fuel No. -35 applies to vehicles operated in districts where the lowest ambient temperature is between -14°C -29°C and the risk rate is 10%.
- Light diesel fuel No. -50 applies to vehicles operated in districts where the lowest ambient temperature is between -29°C -44°C and the risk rate is 10%.

4. Natural gas

China has not fueled any motor-vehicle with liquified natural gas so far and using compressed gas to power motor vehicles is still on trial. In order to save energy resources and to reduce the exhaust emission, those districts and provinces which are rich in natural gas like Sichuan province have adopted compressed natural gas as an alternative fuels for the vehicles which are specially mounted with a large storage bag on the top.

5. Lubricating oil for two-stroke petrol engine

In China, no national standard of lubricating oil for two-stroke petrol engine has been worked out till now. The internal standards of the lubricating oil manufactured by China National Petro-chemical Corporation for two-stroke petrol engine can be seen in attached table 7.

VI. Executive strategy for improving in-use motor vehicle inspections for emission control

1. On the basis of the air quality and the technical level of motor vehicle, motorcycle and vehicle engine manufacturers in China, CO and HC emissions from gasoline engines and smoke emission from diesel powered engines are of first emergency among the items of exhaust emissions to be controlled. Nitrogen oxides in the exhaust emissions from motor vehicles, motorcycles and vehicle engines, and CO, HC and No_x from diesel powered vehicles and vehicle diesel engines are to be controlled gradually in the next place.
2. The exhaust emission control should closely link with energy-saving activities.
3. The maintenance and repair service industry should be well equipped with diagnostic devices for the engines and the operators should know how to use them properly. The maintenance and repair service system should be improved to create the normal technical conditions of an engine and to assure it up to the required national emissional level.
4. The emissions of in-use motor vehicles are controlled on the idling or free acceleration conditions. In order to implement a perfect control of the entire air pollution emissions step by step, in-use motor vehicle should, at the moment, be prevented from crankcase linking and fuel vaporizing with help of forced-equipment method. That

means in-use motor vehicles (except those of which engines take the crankcase in stead of the function of an in-let system) should be equipped with a closed system of forced draft system of fuel vapor control.

5. Motor vehicles and motorcycles should only use such fuels which are of the designed requirement and with an officially marked grade or an officially certificated substitute. Developments of low-lead or lead-free petrois are encouraged.
6. Standard system of the emission control consisting of standards on the testing methods, limit, analysis, sampling, correction and calibration should be completed in stages under a unified program.
7. Research subjects of motor vehicle emission control in the coming days are:
 - A. Research on diesel engine particulates emission control.
 - B. Research and development on the fuels and the lubricating oils.
 - C. Research and development on the analyzers and testing equipments.
 - D. Research and development on the electronically controlled ignition and the lubricating system.
 - E. Research and development on the three-way catalytic converter.

VI. Conclusion

Motor vehicle emissions control and regional air-quality improvement are particularly of benefit to the regional ecological system as a whole. Through an effort of interanational or interregional cooperation network, it is possible in seeking scientific, rapid and effective approaches of motor vehicle emission control to protect regional and even global atmosphere environment. We are always willing to cooperate closely with international or interregional organizations and the experts to make a contribution to the effective improvement of global ecologic environment, and are ready to carry on any necessary organizing and technical works thereby.

SI engine exhaust emission standard

Table 1

Items of detection & measurement	On normal idling conditions		1500-2500r/min idling speed	
	CO%	HC•ppm		
Motor-vehicle (M.V.) classified & date of implementation			4 stroke	2 stroke
Date of issue				
New-model M.V.	4	1500	5500	2.5
Newly manufactured M.V.	4.5	2000	6500	3
In-use M.V.	5.5	2500	7500	4
After Jan, 1. 1995				
Newly manufactured M.V.	4	1500	6000	2.5
In-use M.V. delivered after Jan. 1. 1995	4.5	2000	7000	3.5
After 2000				
New-model M.V.	3.5	1000	5000	2
In-use M.V. delivered before Jan, 1. 1995	5	2500	7500	4

Remark: HC concentration is calculated as (n)-hexane equivalent.

SI engine exhaust emission standard

Table 2

terms of inspection & measurement	M.V. classified	limit
CO	Newly manufactured M.V.	<5%
	In-use M.V.	<6%
HC•	Newly manufactured M.V.	<2500ppm
	In-use M.V.	<3000ppm

Remark: HC concentration is calculated as (n)-hexane equivalent.

Inspection instrument

Table 3

Name of instrument	uses and scope of application	principle of Technical detection parameters	Manufacturer & model
M. V. emission analyzer	For CO and HC concentrations measurement on 4 stroke or 2 atroke-engines and motorcycle emissions. widely used at the standing inspection stations for M. V. performances	INFRAD (NDIR) Measuring range: CO: 0-2%; 0-8%; HC: 500; 2000; 4000; 8000; ppm tability: zero drift $< \pm 3\%$ (full scale/3h) span drift $< \pm 3\%$ (full scale/3h) reproducibility : $< 2\%$ full scale	Model: MEIA-324 Fushan analytic instrument plant
Smokemeter	For smoke intensity measurement of diesel engine on free acceleration and full load conditions	Filter-type Measuring range: Rb0-10 suction capacity: $330 \pm 15\text{ml}$ sampling time: 0.25-1.0s. airtightness: inlet air less than 15ml/min.	Model: FQD-201 Wenzhou instrument plant
Smokemeter	same as above	Filter-type Measuring range: Rb0-10 precision: less than 3% of the full scale suction capacity: $330 \pm 15\text{ml}$ Reproducibility: 2% of the full scale. zero drift: $< \pm 3\%$ after a prehcating of 6min.	Model: FBY Foshan analytic instrument plant
M. V. oxygen analyzer	For gasoline engine exhaust gas oxygen content measurement	Portable basic measuring range: 0-5%, 0-25% Indicating precision: $\pm 5\%$ of the full scale Response time: 20sec.	Model: DJ-11 Tianjin electric condenser plant

general gasoline

table 4

Items of detection & measurement	quality index			Testing
	No. 90	No. 93	No. 97	method
Antiknock performance: Research Octane Number (RON), >	90	93	97	GB5487
Antiknock index $\{(RON+MON)/2\}$, >	85	87	92	GB5487
Lead content, g/l, not more than	0.35	0.45	0.45	GB6536
Distillation range: 10% vaporized at a temp., in °C, >		70		GB6536
50% vaporized at a temp., in °C, >		120		
90% vaporized at a temp., in °C, >		190		
Final boiling point, in °C, >		205		
residue, %, not higher than		2		
Vapour pressure in Kpa. from 1 Sept. till 29 Feb., >		88		GB8017
From 1 Mar. till 31 Aug., >		74		
Actual gum, mg/100ml, not more than		5		GB8019
Inductive phase, min., >		490		GB256
Sulfur content, %, not higher than		0.15		GB380
Copper corrosion grade, >		1		GB5096
water-soluble acid or alkali		none		GB259
Acidity, mg. as KOH/100mg, >		3		GB379
Mechanical impurities & water		none		
Deceit test		pass		IRE31002

Remark: The alkylated antiknock petrol should be strikingly marked with the lead indication colour. these data come from the national standard GB484-85.

lead-free gasoline

table 5

Items of detection & measurement	quality index			Testing method
	No. 90	No. 93	No. 97	
Antiknock performance: Research Octane Number (RON), >	90	93	97	GB5487
Antiknock index $\{(RON+MON)/2\}$, >	85	89	92	GB5487 GB503
Lead content, g/l, not more than	0.013			GB8020
Distillation range: 10% vaporized at a temp., in °C, >	70			GB6536
50% vaporized at a temp., in °C, >	120			
90% vaporized at a temp., in °C, >	190			
Final boiling point, in °C, >	205			
residue, %, not higher than	2			
Vapour pressure in Kpa. from 1 Sept. till 29 Feb., >	88			GB8017
From 1 Mar. till 31 Aug., >	74			
Actual gum, mg/100ml, >	5			GB8019
Inductive phase, min., >	480			GB256
Sulfur content, %, not higher than	0.15			GB380
Copper corrosion grade, >	1			GB5095
water-soluble acid or alkali	none			GB259
Acidity, mg, as KOH/100mg, >	3			GB379
Mechanical impurities & water	none			
Doctor test	pass			IRE31002

Remark: The standard sets a limit for lead content and should not be added consciously up to the limit anyway.

light diesel fuel

Table 6

Items of detection & measurement	Quality	firrst grade	Qualified	testing method	
Iodine number, I ₂ g/100g, >	6	-	-	SY2114	
Colour, colourity, >	3.5	3.5	-	GB5540	
Acclerating stablized deposit, mg/100ml, >	-	2.0	-	SY2150	
Actual gum, mg/100mg, >	-	-	7.0	GB509	
Sulfur content, % >	0.2	0.5	1.0	GB380	
sulfur content in thio-alcohols, %, not higher than	0.01	0.01	-	GB1792	
water, %, not higher than	trace	trace	trace	GB260	
Acidity. mg. KOH/100ml. >	5	5	10	GB268	
10% Distillation, Carbon residue, %, >	0.3	0.3	0.4	0.3	GB268
Ash, %, not higher than	0.01	0.01	0.02	GB508	
Copper corrosion grade, (50°C, 3h), not higher than	1	1	1	GB5096	
water soluble acid or alkali	none	none	none	GB259	
Mechanical impurities	none	none	none	GB511	
Hexadecane number	45	45	45	GB386	
Distillation range: 50% vaporized at a temp., °C, not higher than	300	300	300	GB6536	
90% vaporized at a temp., °C, not higher than	355	355	355		
96% vaporized at a temp., °C, not higher than	365	365	365		
Density (20°C), kg/m ³				GB1884	

Table 6 continued

Items of detection & measurement	for all grades of fuel						testing method
	3.0-5.0		2.5-5.0		1.5-7.0		
Kinematic viscosity (20°C), mm ² /s	3.0-5.0		2.5-5.0		1.5-7.0		GB265
Condensation point, °C, not higher than	10	0	-10	-20	-30	-50	GB510
Condensing point, °C	12	4	-5	-14	-29	-44	SY2413
Closecup flashpoint, °C	55			45			GB261

Data resource : GB252-87.

2-stroke SI engine oil standard

Table 7

Items of detection & measurement	Quality index	Testing method
Appearance	Brownish-red oily liquid	by eye
Kinematic viscosity (100°C), mm ² /s	9.3-12.5	GB265
Open-cup flashpoint, °C, not lower than	150	GB267
Condensation point, °C, not higher than	-10	GB510
Ash, %, not higher than	0.40	GB508
Carbon residue, %, not higher than	0.50	GB268
Mechanical impurities, %, not higher than	0.01	GB511
Maximum load on smooth operation conditions (P ₃), N	report	GB3142
Diameter of abrasion spot, D (30kg/30min.), mm	report	GB3142
Density (20°C), kg/m ³	report	GB1864

Data resource: Internal standard for China National Petrochemical Corporation.

COUNTRY PAPER
VEHICLE EMISSION CONTROL IN HONG KONG

UNDIO
United Nations Development Programme

Presented to the Expert Meeting on
In-use Motor Vehicle Inspection for Emission Control
20-22 Oct 1992, Seoul, Rep. of Korea

Presented by: Mr. Kong Ha
Vehicle Emission Control Section
Hong Kong Environmental Protection Department

1	Summary	1
2	National Focal Point	1
3	Organisation Chart	1
4	Control of Air Borne Emission from Motor Vehicles	
	-List of Related Ordinances and Regulations	2
5	Vehicle Classifications in Hong Kong	3
6	Status of Control of Vehicular Emission in Hong Kong	3
7	Some Background of Air Quality in Hong Kong	4
8	Fleet Population and Vehicle-kilometre Travelled	4
9	Estimated Tonnage of Emission from Motor Vehicles	5
10	Short, Intermediate & Long Term Solutions to Tackle Vehicle Emission .	5
11	Brief Information on the Smoky Vehicles Control Program	6
12	The Way Forward	8

Attachments:

-National Focal Point

-Charts

-Comments on the Guidelines for In-use Motor Vehicle Inspections

1. Summary

This country paper briefly describes the vehicle emission related air quality problems experienced in Hong Kong.

The current control status, both regulatory and enforcement issues, are also described. The most pressing problems of particulate and NOx pollution are identified. Draft 1994 and 1998 emission standards are proposed to tackle the problems.

Short, intermediate and long terms draft strategies are laid out in this paper.

Finally this short draft paper shares some of the operational experience learned from the last 4 years of operation of smoky vehicles control program.

2. Nation Focal Point

In relation to the matters of vehicle emissions with respect to legislations, policies and controls, the national focal point for Hong Kong is:

Mr. Kong HA

Senior Environmental Protection Officer
Environmental Protection Department
33/F, Wan Chai Tower 3,
5 Gloucester Road,
Wan Chai,
Hong Kong.

Country code: 852
Tel: 594 6414
Fax: 827 8040

3. Organisation Chart

The Vehicle Emission Control Section of the Hong Kong Environmental Protection Department is responsible for the matters of formation of policies, development and introduction of control technologies and implementation of emission control program. The section is headed by a Senior Environmental Protection Officer, and assisted by 3 Environmental Protection Officers and a team of 15 technical and clerical supporting staff.

The work of the section is divided into three major areas:

- 1) Policy and development of emission control strategies and legislation, including standards on fuel properties and vehicle emission;
- 2) Technical services and introduction of new technologies in vehicle emission control, including applications on-new and in-use vehicles;
- 3) Enforcement of vehicle smoke control program.

The senior officer reports to the Principal Environmental Protection Officer, head of the Air Services Group, who reports to the Assistant Director of the Air and Noise Division, AD(AN). AD(AN) is held responsible by the Director of Environmental Protection.

Draft policies will be put forward to the Policy Branch of Planning, Environment and Lands for decision making.

(See attachment chart 1)

4. Control of Air Borne Emission from Motor Vehicles - List of Related Ordinances and Regulations

Automotive Fuels

Fuel Type	Effective Date	Regulations/Ordinance	
Unleaded Petrol	Apr 1991	Air Pollution Control (Amendment) Ordinance 1991	*
Diesel	Proposed 1994 & 98	Draft proposed specifications	

Emission Standards (New Register Vehicles)

Present:	Air Pollution Control (Vehicle Design Standards (Emission) Regulations 1991	*
1994:	Draft Emission Standards for Heavy Duty Vehicles	
1998:	Draft Emission Standards for Heavy Duty Vehicles	

Emission Standards (In-use Vehicles)

Present:	Road Traffic (Construction and Maintenance of Vehicles) Regulations	*
1994:	Draft In-use Emission Standards for ALL Vehicles	

Inspection of In-use Vehicles

Present:	Road Traffic (Amendment) Ordinance	*
----------	------------------------------------	---

*(These documents in gazette form are available from the nation focal point)

Our regulations reflect that the approach we are taking is technology complying, not forcing. However in future we don't want to be too far behind from the most advance applicable technology.

5. Vehicle Classifications in Hong Kong

(Ref: Road Traffic (Construction & Maintenance of Vehicles) Regulations

Class	Maximum Passenger Seating Capacity	Maximum Gross Vehicle Weight (kg)
Passenger Carrying Vehicles:		
Private Car	7	3,000
Taxi	5	3,000
Public/Private Light Bus	16	4,000
Public/Private Bus	17+	24,000
Goods Carrying Vehicles:		
Light Goods Vehicle	5	5,500
Medium Goods Vehicle	5	24,000
Heavy Goods Vehicle	5	38,000

6. Status of Control of Vehicular Emissions in Hong Kong

1) Petrol engined vehicles

Under the Air Pollution Control (Vehicle Design Standards) (Emission) Regulations 1991, Cap. 311 of Law of Hong Kong, all petrol engined vehicles registered on or after 1.1.92 must use unleaded petrol.

The regulation also lay down the design standards of passenger cars and light duty vehicles below 2500kg GVW to conform to the current US and/or Japanese emission standards.

2) Diesel engined vehicles

Under the aforementioned regulation the design standards of passenger cars and light duty vehicles below 2500kg GVW are required to conform to the current US and/or Japanese emission standards.

The aforementioned regulations are being amended to incorporate the latest 91/441/EEC directive.

3) Unleaded petrol specifications

Unleaded petrol of Hong Kong, as defined in the Air Pollution Control Amendment Ordinance, is of minimum RON and MON of 95 and 85 respectively. Lead and sulphur contents are also limited to maximum of 0.013 g/L and 0.1% respectively.

7. Some Background of Air Quality in Hong Kong

Background of local air quality in relation to vehicular emissions

Ambient air quality objectives (AQOs) are being implemented in Hong Kong which are of similar stringency as in the US. (Table 2)

Among the pollutants being specified, the Total Suspended Particulates (TSP), Respirable Suspended Particulates (RSP) and Nitrogen Dioxide (NO₂) are of concern. In urban areas, the TSP and RSP level are consistently exceeding their respective AQOs while the NO₂ level is at the marginal level. It was estimated that vehicular emission contributed approximately 75% of both particulate and nitrogen oxides (NO_x) emissions and, thus, are the major source of pollution.

Further information can be obtained from the Principal Environment Protection Officer of the Air Services Group of the Hong Kong Environmental Protection Department.

8. Fleet Population and Vehicle-kilometre Travel

(See attachment figures 3 & 4)

The city state of Hong Kong is a dense development comprising residential, commercial and industrial activities. In most places, situations of mixed goods and passenger transports can be found. The situation is even worse with the "old towns" where traffic flow volume, passenger and goods embarkment are difficult to manage in terms of minimizing emission from vehicles and its impact on people in the area.

The terrain of Hong Kong varies significantly, with high rise buildings along main roads, forming typical street canyons. Dispersion modeling on situations like this is difficult, and, although new town planning being exercised is improving the air pollution impacts on people, such benefit is not shared by the people living in the old towns.

9. Estimated Tonnage of Emission from Motor Vehicles

Trend of pollutant emission from motor vehicles

It is estimated that by 2001, there would be some 65% increase in particulate and NOx emission as compared with 1992 level due to the expected increase in traffic volume. (See figures 5 & 6)

Figures 7 & 8 shows the breakdown of the pollutant contribution by class for 1992 and 2001. It can be observed that goods vehicles and buses are the major contributors and they are primarily Diesel engined vehicles.

With the expected growth in traffic volume, the situation will get worse and hence the "at source" control of vehicular emission is a must as a solution to improve air quality of Hong Kong. This requires stringent control on emissions from new and in-service vehicles.

Of course one should not ignore the important role of proper planning on transportation arrangements in the areas of demand, utilization, routing etc. not only to minimize the impact of emission on the environment, but also to emit as little pollutant as possible to assist the global environment.

10. Short, Intermediate and Long Term Solutions to Tackle Vehicle Emission

See chart 9.

All the light duty petrol vehicles would be regulated using the most stringent standards feasible.

A program to upgrade the medium and heavy duty Diesel vehicle regulations is being formulated in the draft proposal aiming at US standards or equivalent of 0.6 g/bhp-hr particulate and 5 g/bhp-hr NOx standards by 1994 and 0.1 g/bhp-hr particulate and 4 g/bhp-hr NOx standards by 1998. Feasibility of accelerated program for urban buses to advance the 98 standard to 96 is also being considered.

In parallel with the Diesel program, the required low sulphur Diesel fuel supply is under negotiation with the oil industry targeting at 0.2% by 1994 and 0.05% by, or, no later than 1998. The objective is to have low sulphur fuel standards set in parallel with the requirements of particulate emission standards.

The draft will also propose all new vehicles be required to carry emission warranty. The warranty will form the foundation of implementing in-use emission standards and inspection and maintenance programs.

To address the problem of nuisance of Diesel black smoke and the resulting higher particulate emission, this office will propose that all Diesel vehicles must maintain below HSU 40 at tailpipe, as measured with accessory load, throughout its useful life. In fact the HSU 40 may be a convenient point to define useful life!

Also the possibility of retrofitting of particulate trap oxidizer (PTO) on some existing heavy duty Diesel vehicles such as urban buses, where they usually last for about 20 years, is being considered. Feasibility study/demonstration programs are being looked into.

In short, there does not seem to be an overnight solution to directly tackle emissions from various classes of vehicle and address the requirements by the air quality objectives. Introduction of unleaded petrol (ULP) and three way converter (TWC) technology was a corner stone for the development of vehicle emission control, which the solution for Hong Kong lays more in the proposed intermediate and long term strategies of most stringent light duty petrol and heavy duty Diesel emission standards, and the technology development in light duty Diesel vehicles.

11. Brief Information on the Smoky Vehicles Control Program

Implementation of the Smoky Vehicles Control Program in Hong Kong

(Reference chart 10 and table 11)

Under the Road Traffic (Construction and Maintenance of Vehicles) Regulations of Hong Kong, vehicle emitting excessive smoke is illegal. The regulation defined excessive smoke as 60 HSU as tested by Hartridge Mark 3 smoke meter.

Hong Kong Environmental Protection Department is running a spotter program where some 450 trained volunteers will report smoky vehicles spotted to the enforcement agency. In 1988 the program started to test smoky vehicles by one testing centre operated by Environmental Protection Department alone. The testing capacity was then expanded by adding designated private testing centers in 1991. Currently there are 20 such private centres.

Data of the reports received from spotters would be verified by comparing with the vehicle register via a computer link. Incorrect data or vehicles under action by the authority would be screened out. Typically the wastage rate is about 40%.

An emission testing notice would then be issued according to the actionable reports. The notices are sent to the registered owners of vehicles concerned by registered mail. At the same time a computer code will be added to the vehicle register to prevent vehicles under action from licence renewal or transfer. The notice will require the vehicle owner to correct any defect of the vehicle and have it presented to any one of the 20 designated centres for emission testing.

Free acceleration test procedure is adopted for testing with maximum limit set at 60 HSU. Vehicle being tested would be put in neutral transmission, with clutch engaged, at idle and the accelerator pedal would be depressed to its maximum travel until the engine speed achieve its governed maximum speed and then release immediately. The process would be repeated for 3 times to clear any loose soots inside the exhaust system. The same free acceleration procedure would be repeated for 3 time and a Hartridge Mark 3 smoke meter is used for the smoke measurements. Maximum allowable deviation of the measured results is 5 HSU and the average of 3 valid measurements would be taken as the test result.

A limited time period (currently 18 days from the date of notice) would be given to the owners to obtain an emission certificate of compliance from the testing centres. Owners whose vehicle failed to comply to the HSU 60 standard or fail to present the vehicles for testing, would result in the vehicle licences being cancelled.

Training is provided to the testers of the testing centres by the Environmental Protection Department. Also their operations are guided by the authority in the form of code of practice.

Following are some enforcement statistics:

(Refer to table 12)

Some experience in the operation of the smoke control program

In parallel to the smoke control program, Environmental Protection Department also conducts a roadside survey to monitor the trend of the percentage of smoky vehicles. Data collected so far is not sufficient to draw any solid conclusion, but the results seems to show:

- a) there are fewer 100HSU smoky vehicles as it was,
- b) the program tends to be more effective for light buses and taxis which most of our spotters are active,
- c) a higher awareness to the public and to Diesel vehicle owners of the smoke problem.

An estimation was made to check how effective the smoke test is in rectifying smoke defects and to maintain the vehicle in the state of tune (i.e. no excessive smoke) within 12 months after the inspection. It was revealed that on average only 33% of vehicles tested will remain in an "acceptable" smoking level within 12 months after passing an inspection. The percentage varies with vehicle classes. Light duty vehicles such as taxis and light buses exhibit more frequent smoke problems. Technical report is available from the national focal point on request.

The variation between the passing rate of 80% and the estimated effectiveness of 33% indicates that the inspection procedure

itself is not stringent enough to reflect the actual on load operation conditions. It is also believed from field experience that tampering of fuel injection equipment to pass inspections and reset to a higher fuelling level afterward does exist among some operators to avoid actual maintenance work on the engine. Hence physical inspection on the injection equipment may be one of the solutions to the smoke problem.

The other problem with the free acceleration test procedure is that it failed to reflect the on-load road running operation condition and may not able to rectify some defects. Therefore the application of artificial loading such as air-conditioning and electric loading during the test is being investigated and considered.

The second issue is the leniency provided by the private inspection centres in reporting smoke test results. Figures 13 & 14 shows the frequency and cumulative frequency of the smoke test results respectively. It was noted that most results falls within the band from 40-60 HSU. In figure 14, the cumulative frequency for results from private centre exhibit a hump for HSU just below 60, while for results from EPD centre is smooth throughout. It is obvious that testers will most likely report results slight above 60 HSU as below 60 HSU to allow a pass, though the average passing rate for private centres is just a couple percentage points above EPD's results.

12. The Way Forward

The discussion above had unfold the problems of smoke nuisance, particulate and NOx pollution in Hong Kong.

The analysis has en-vised the primary objective of the Vehicle Emission Control Section to enact on the "at source" control of vehicular emissions.

Heavy duty vehicles, whom were identified to has contributed majority of urban air pollutions, must relay on the medium and long term strategies in introducing the world most stringent emission standards and best available control technology for Hong Kong.

Standards for light duty petrol vehicles will be kept upgrading as long as it is required. The development in transitional low emission vehicles (TLEVs), low emission vehicles (LEVs) and the zero emission vehicles (ZEVs) would then become the backbone of our control tools.

The two aforementioned items of air-conditioning and electric loading will be added to the smoke test procedure.

An emission warranty would be required for all new cars, which would define the responsible parties and liabilities, coupling with an I&M program would keep the deterioration of petrol vehicle to a minimum. Such approach would become the future shape of our in-use vehicle emission control.

While there is little development in light duty Diesel emission control technology worldwide, our targeting classes of vehicles such as taxis and light buses may have an unknown future. Until there is a clear indication or break through of real possibility of smokeless as well as odorless light duty Diesel vehicles, we will keep working on the strategy of reduce reliance on light duty Diesel vehicles, which may include a forced shift to alternative fuels.

END

With respect to the Guidelines for In-use Motor Vehicle Inspection for Emission Control in the Asia-Pacific Region, we, the Hong Kong Environmental Protection Department would like to make comments as follow:

1. **Certification of small quantity production vehicles:**
For small city states such as Hong Kong where vehicle supplies are solely depended on importation, it would be difficult to make special arrangement for small quantity production cars. Our opinion is that if the vehicle manufacturers concerned is not able to fulfill COP requirements, then individual emission certificate should be required for each vehicle to be registered.
2. **Limit or tax on the age of second hand vehicles:**
Currently there is favourable taxation rate on First Registration Tax (FRT) for used vehicles, working to the depreciation of the value of the vehicles. Limit on vehicle age or added tax may violate the spirit of free port Hong Kong is adopting.

Furthermore some vintage cars are of economical value while actually making less pollution due to their limited on road running mileages.

In fact Hong Kong has adopted the regulation such that all vehicles to be registered after 1.1.1992, both new or used, must conform to the current emission standard which will require TWC technology and must use ULP. The only exceptions are vintage cars of 20+ years old and private imports for expatriates.

3. **COP requirements and inspection for registration and licence renewal:**
There is no COP requirement for Hong Kong. Pre-registration inspections are only limited to goods and passenger service vehicles.

Annual inspection on smoke is limited to taxis and buses. No emission check on petrol vehicles is required.

This office holds the view that regular inspection on emission related items must be adopted in future so that the deterioration of the emission control systems could be kept under control.

4. **Fines and licence cancellation on violation of emission limits:**
Licence cancellation is being enforced in Hong Kong. However if the fine is too low, then offenders would just pay the fine instead of maintaining/repairing their vehicles.
5. **Maintenance, spare parts, mechanic cost and equipment level:**
We believe the use of non genuine parts is a problem impacting on emission performance. Hence using certified parts of critical effect on emission performance should be a direction to go. Generally speaking the cost of equipments for smoke and CO checking at engine idle condition is not substantial.
6. **Inspection functional groups:**
Mobiles: must clarify the objective of roadside checking since it is highly manpower intensive and probably create traffic slow down. Deterrent effect?
Local stations and repair shops: a comprehensive code of practice must be straightly observed.
7. **Inspection methods:**
smoke - related to particulate. Accessory and air conditioning load suggested.
CO & HC - recommend to determine the conversion efficiency and Lambda of the catalyst.
NOx - a problem for Hong Kong, how to check?

☐☐☐ National Focal Point:

In relation to the matters of vehicle emissions with respect to legislations, policies and controls, the national focal point for Hong Kong is:

Mr. Kong HA
Senior Environmental Protection Officer
Environmental Protection Department
33/F, Wan Chai Tower 3,
5 Gloucester Road,
Wan Chai,
Hong Kong.

Tel: (852) 594 6414
Fax: (852) 827 8040

Organisation Structure of Hong Kong Environmental Protection Department on Vehicle Emission Control

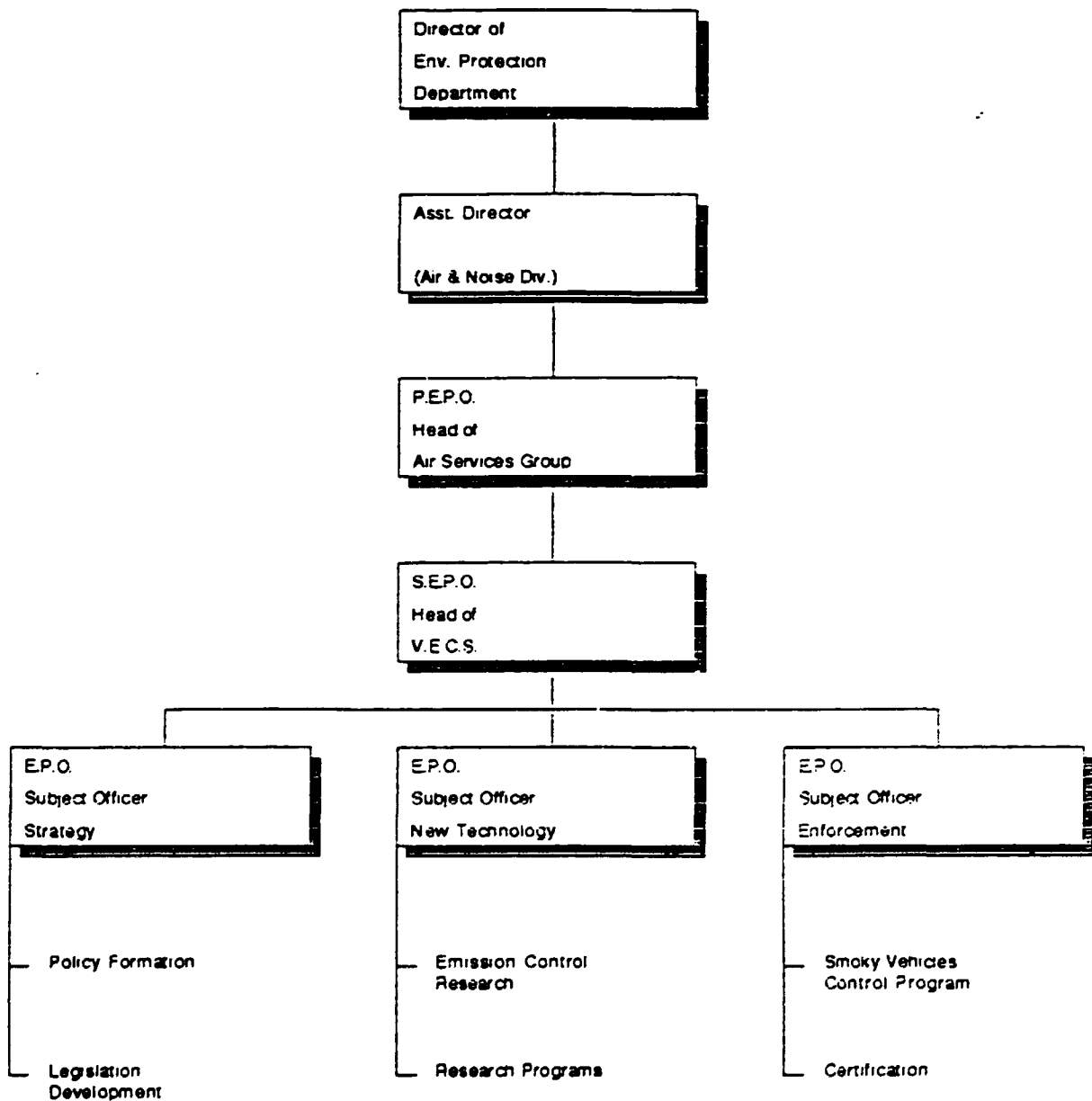

V.E.C.S. - Vehicle Emission Control Section
 PEPO/SEPO - Principal/Senior Environmental Protection Officer
 EPO - Environmental Protection Officer

CHART 1

Air Quality Objectives (AQOs) of Hong Kong

<u>Pollutant</u>	<u>1 hr</u>	<u>8 hrs</u>	<u>24 hrs</u>	<u>3 mths</u>	<u>1 yr</u>
Sulphur Dioxide	800	-	350	-	80
Total Suspended Particulates	-	-	260	-	80
Respirable Suspended Particulates	-	-	180	-	55
Nitrogen Dioxide	300	-	150	-	80
Carbon Monoxide	30000	10000	-	-	-
Ozone	240	-	-	-	-
Lead	-	-	-	1.5	-

All units in micro gram per cubic metre

Table 2

Total Vehicle Population as at Sept 92

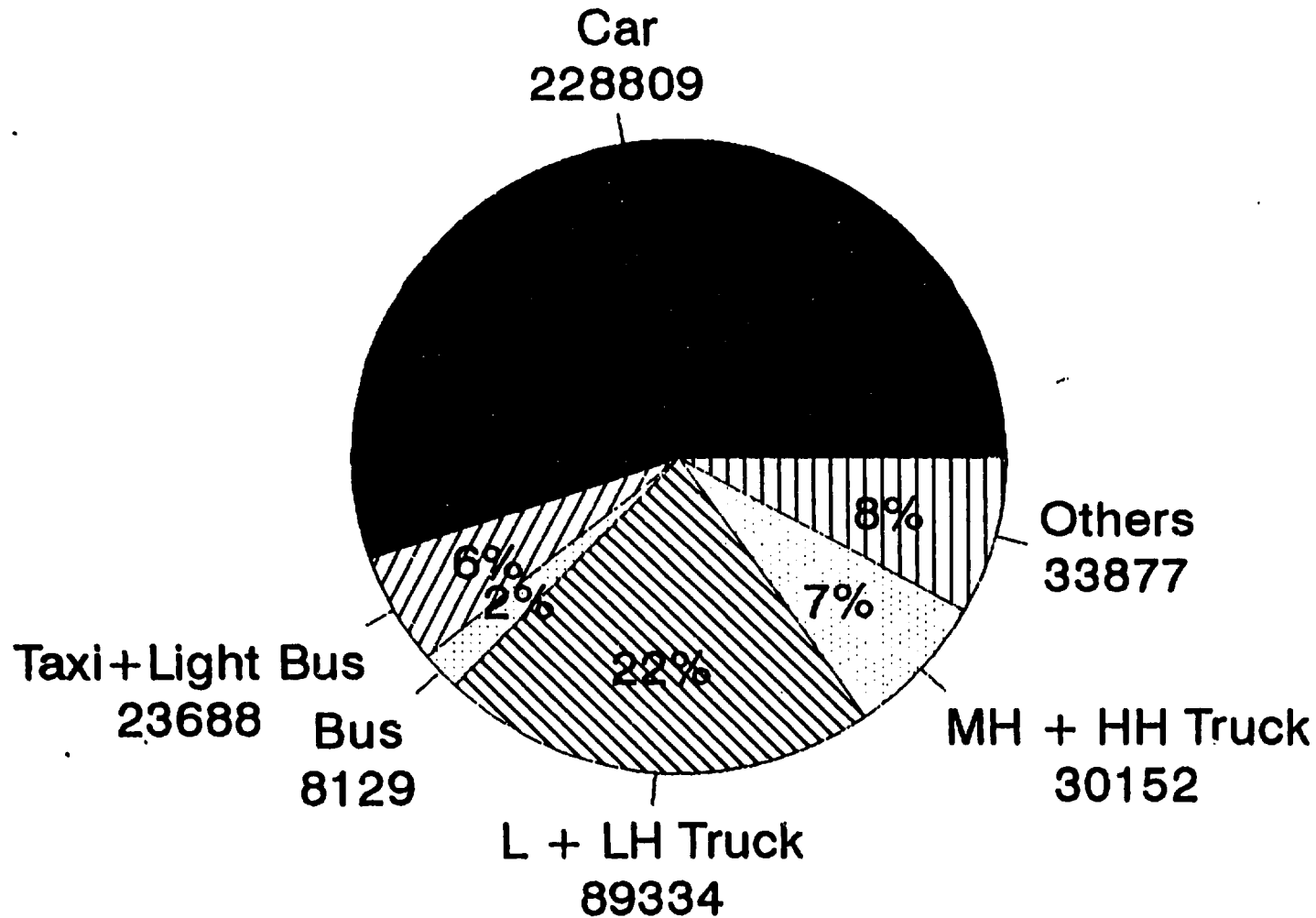

Data from Vehicle register
L - Light LH - Light Heavy
MH - Medium Heavy HH - Heavy Heavy

Figure 3

Petrol & Diesel Vehicle Population as at Sept 92

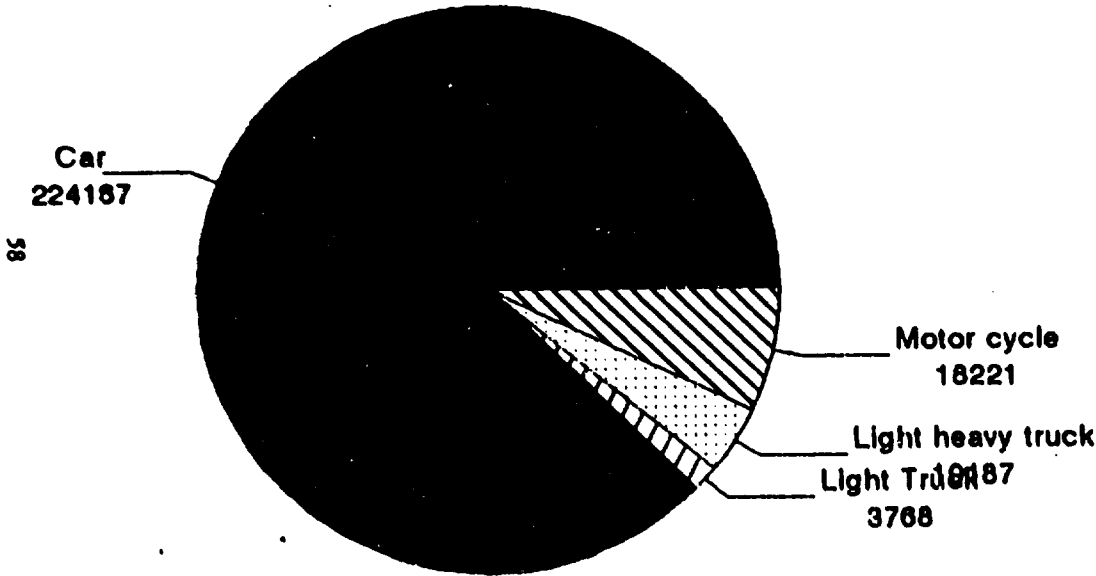

Petrol

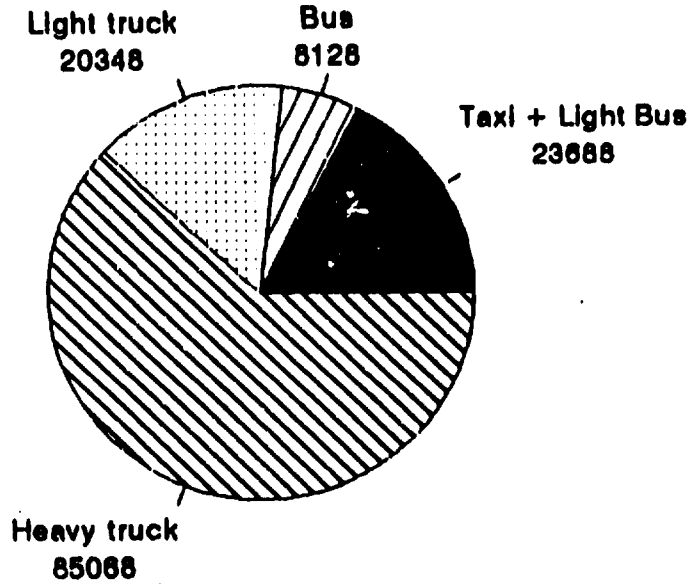

Diesel

Figure 4

Estimated Total Particulate Matters Emission From Motor Vehicles (Current Control Measures)

Normalized Total PM Emission

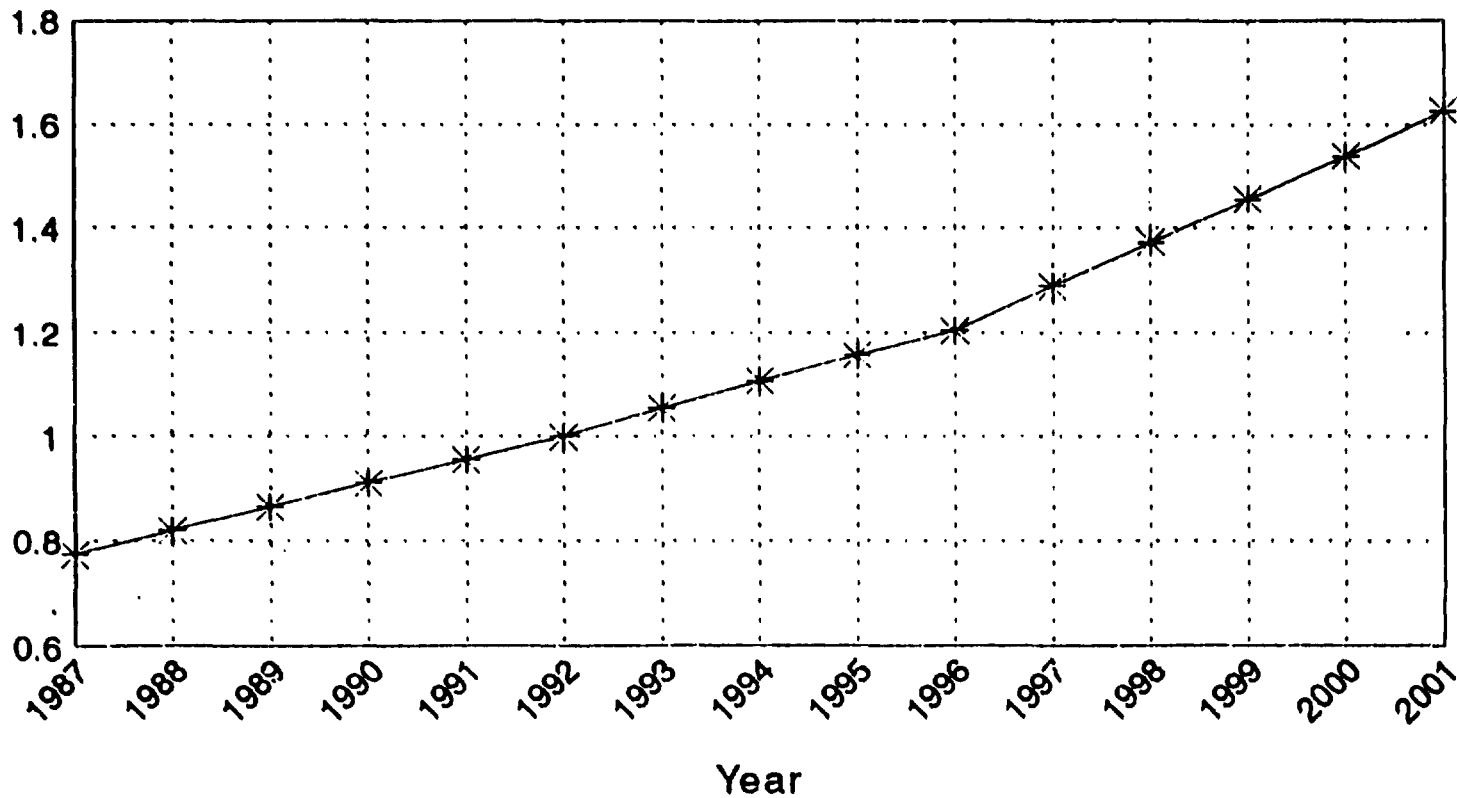

For light duty cars and trucks < 2500kg GVW
PM std. equivalent to current US Federal std.
No PM control on vehicles > 2500kg GVW

Figure 5

Estimated Total Nitrogen Oxides Emission From Motor Vehicles (Current Control Measures)

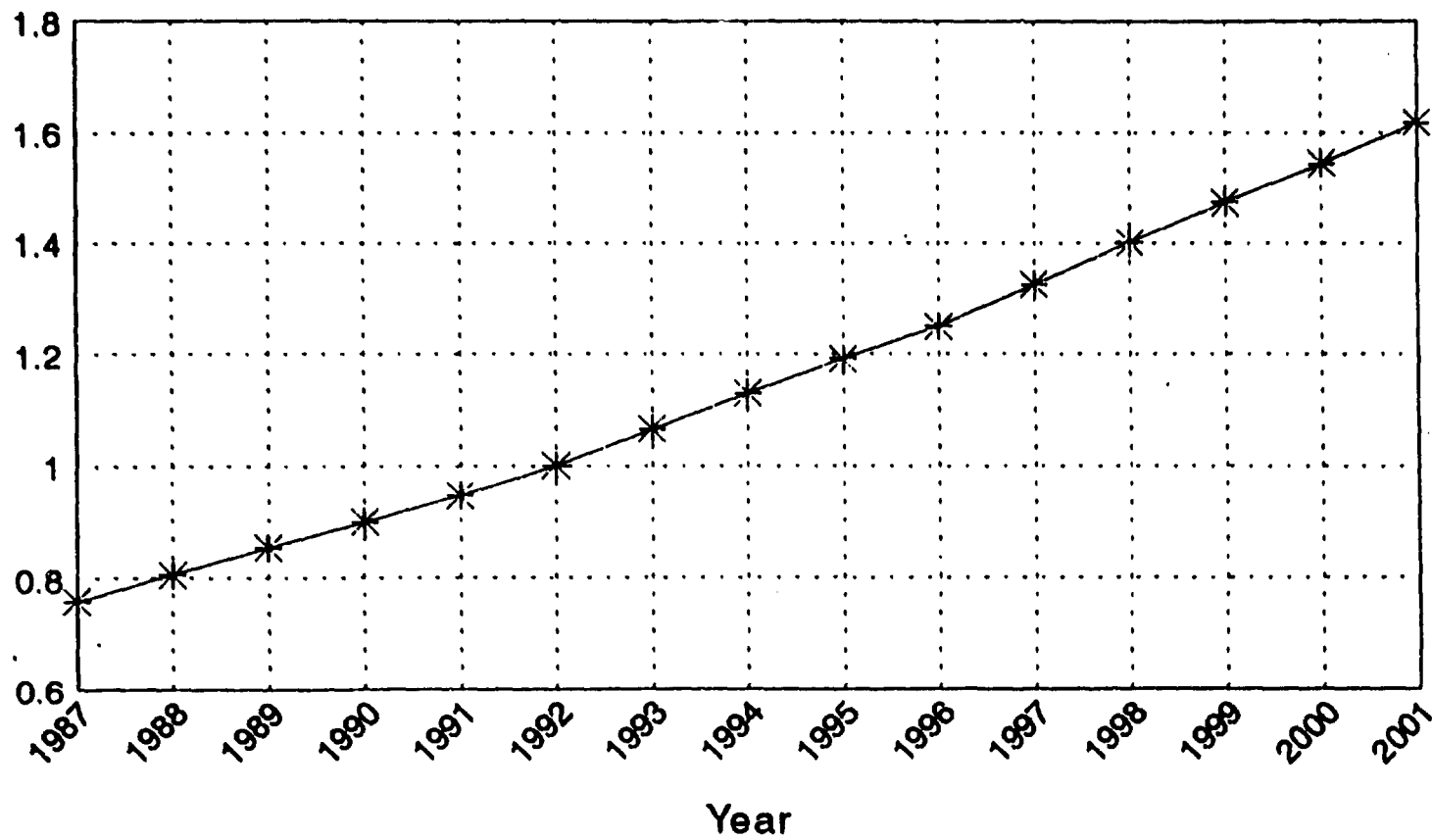

For light duty cars and trucks < 2500kg GVW
NOx std. equivalent to current US Federal std.
No NOx control on vehicles > 2500kg GVW

Figure 6

Particulate Contribution Breakdown by Vehicle Class for 1992 and 2001

19

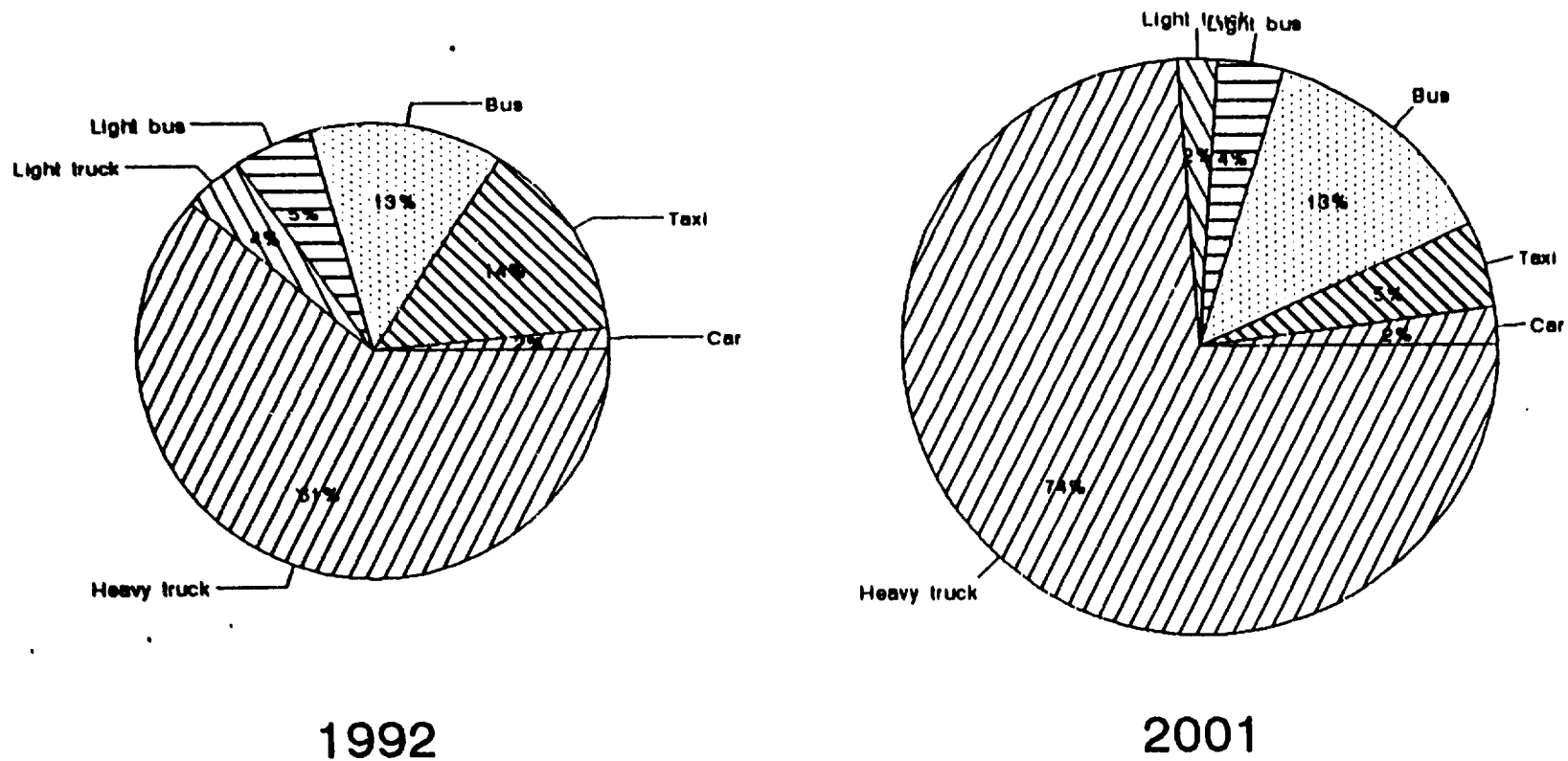

Figure 7

Nitrogen Oxides Contribution Breakdown by Vehicle Class for 1992 and 2001

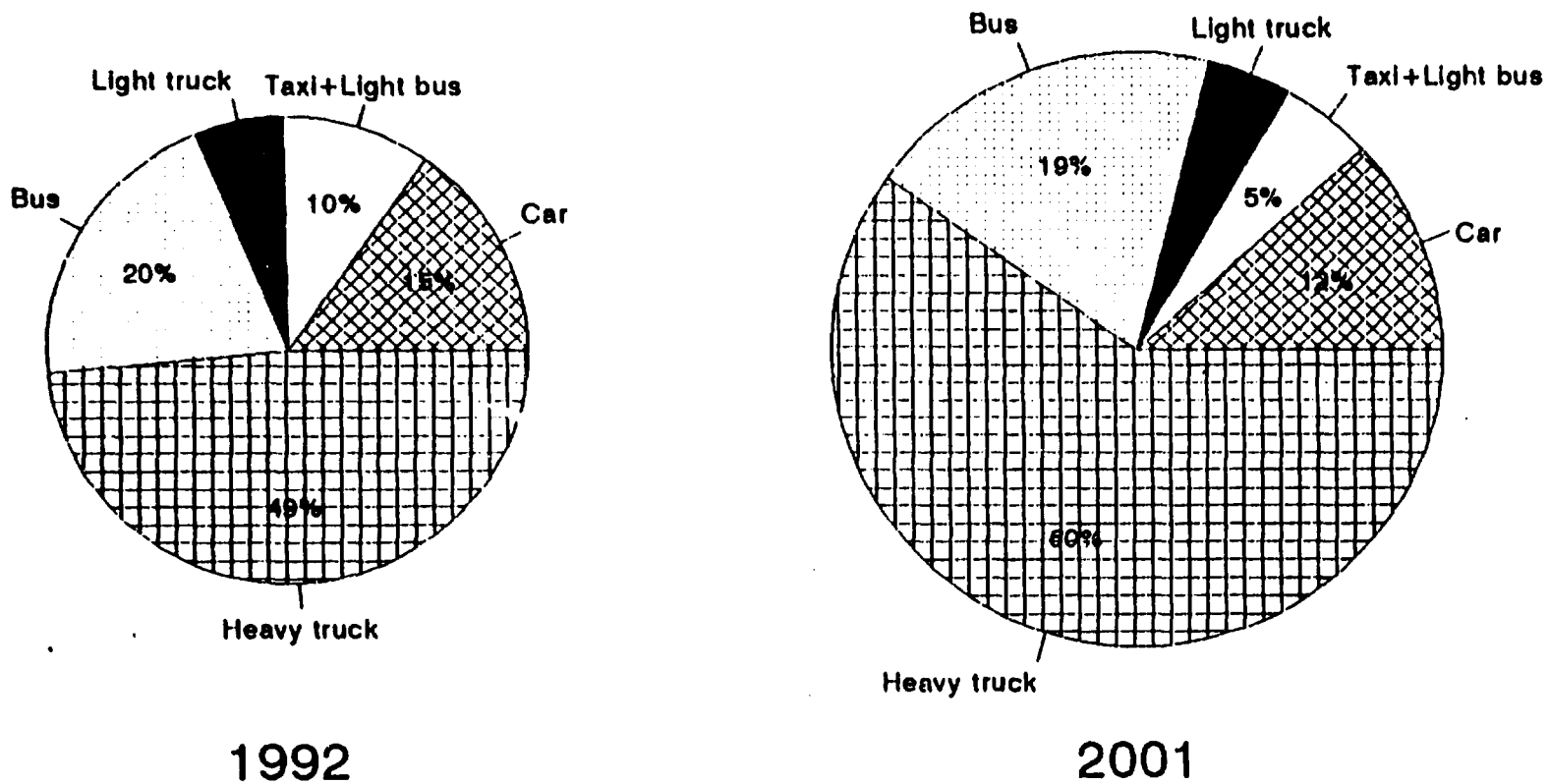

Figure 8

Proposed Motor Vehicle Emission Control Strategy for New Vehicles

Vehicle Class	Approx. Popu. as of Sep 92	Short 92-94	Intermediate 94-97	Long 98 and after
► Diesel				
Car	4600	ULP & TWC	I&M	LEV's
Taxi	17000	Smoke Ctrl. Prog.	91/441/EEC + stringent I&M	ULP & TWC ? (Alt. fuels)
Light Van	20000	Smoke Ctrl.	91/441/EEC + I&M	ULP & TWC ?
Light heavy truck	55000	Smoke Ctrl.	US 90 or equiv.	US 98 or Equiv.
Medium heavy truck	27000	-ditto-	-ditto-	-ditto-
Heavy heavy truck	1000	-ditto-	-ditto-	-ditto-
Light bus	4000	Smoke Ctrl.	91/542/EEC + stringent I&M	ULP & TWC ? (Alt. fuels)
Bus	5000	Smoke Ctrl. + Retrofit	US 90 or equiv.	US 98 or Equiv.
Others	minimal	-	-	-

63

All new standards will be complemented with emission warranty
 Alternative fuels: reformulated gasoline, LPG, NG etc.

Proposed Motor Vehicle Emission Control Strategy for New Vehicles

Vehicle Class	Approx. Popu. as of Sep 92	Short 92-94	Intermediate 94-97	Long 98 and after
▶Petrol				
Car	230000	ULP	TLEVs	LEV's
Light Van	4000	ULP	TLEVs	LEV's
Light heavy truck	10000	ULP	TLEVs	LEV's
Medium heavy truck	minimal	-	-	-
Heavy heavy truck	minimal	-	-	-
Light bus	minimal	-	-	-
Bus	minimal	-	-	-
M/C+Others	18000	-	-	-

All new standards will be complemented with emission warranty

Organisation of Control Setup of Smoky Vehicle Control Program

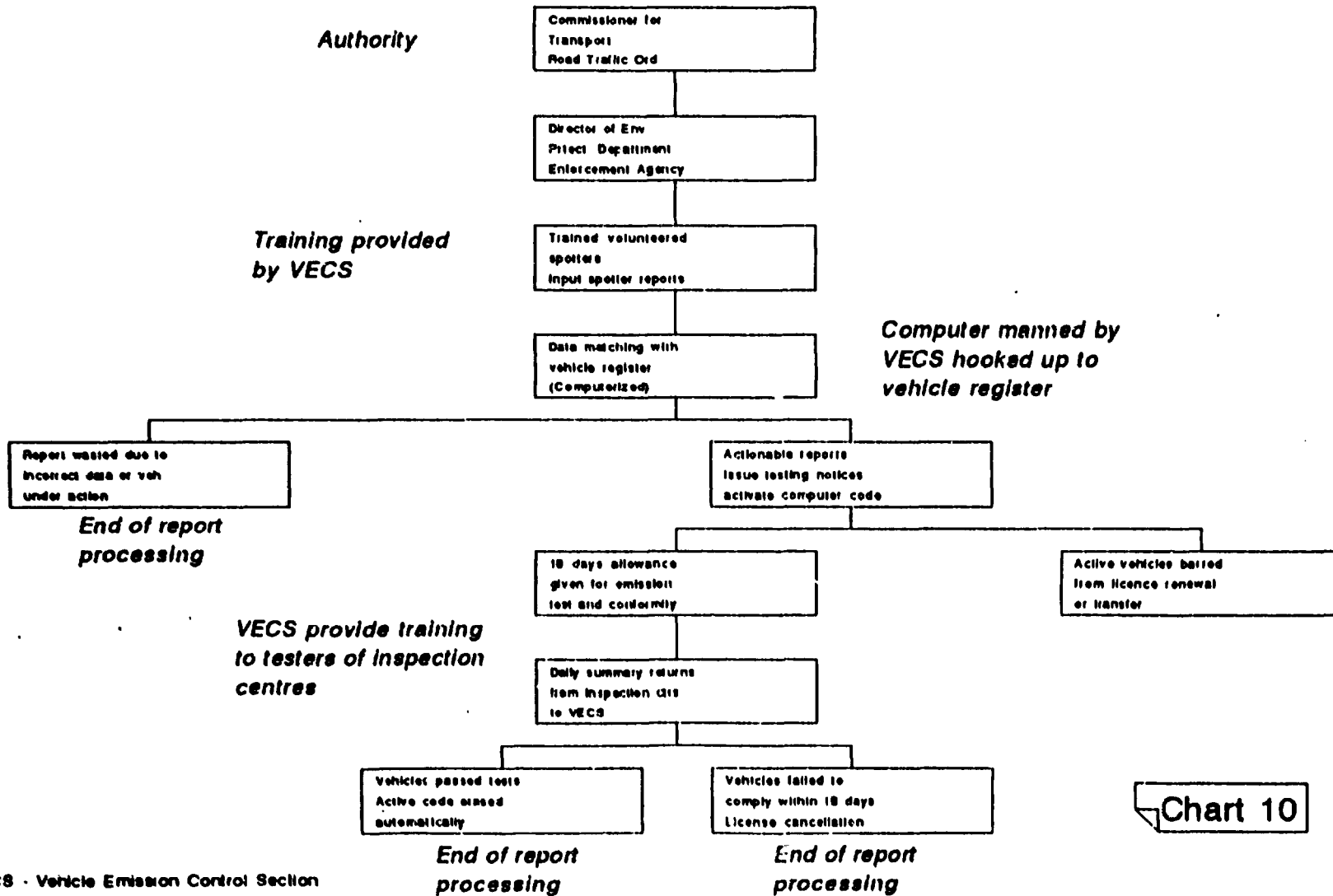

Chart 10

Smoky Vehicles Spot and Inspect Program Operated by the Hong Kong Environmental Protection Department

- ▶ **Objective:** To encourage vehicle owners to maintain their vehicles regularly
- ▶ **Target:** Vehicles emitting excessive smoke while operating on the road
- ▶ **Control mode:** Trained spotters to spot smoky vehicles for excessive smoke, subsequent inspection(s) at designated centres until vehicles passes in-use emission standard (HSU 60 tested by free acceleration method)
- ▶ **Status:**
 - Program started: 1988
 - Number of spotters: 450
 - Number of inspection centres: EPD (1)
 - Designated private (20)
 - Estimated number of inspection for 1992: 43,000 vehicle-inspections
 - Test fee: HK\$140 per every and subsequent inspections
 - Current passing rate: 80%
- ▶ **Functional groups:**
 - Enforcement regulations:** In-use emission standard (60 HSU smoke) (Road Traffic Regulations)
 - Enforcement agency:** Environmental Protection Department
 - Control mode:** Requiring the vehicle owners to serve inspection notice issued by the authority
 - Initiation mode:** Reports from trained volunteered spotters
 - Call up mode:** Inspection notices to vehicle owners by registered mail
 - Inspection mode:** decentralized
 - Inspectors:** Testers trained by the enforcement agency
 - Control of inspectors:** Code of practice issued by the agency
 - Penalty of non-conformity of standard:** Cancellation of vehicle license 18 days after notice issued
- ▶ **Organisation of control setup:** see chart
- ▶ **Test procedures:** No load free acceleration
 - Authorized equipment:** Hartridge Mark 3 partial flow meter
 - Limit:** 60 Hartridge smoke unit (HSU)
- ▶ **Enforcement statistics:** see charts
- ▶ **Effectiveness:** 33% of inspections results in no reappearance of smoke problem within 12 months
- ▶ **Experience of enforcement:**
 - centralized Vs decentralized: reservation in marginal readings (see charts)
 - testing method: insufficient to rectify problems
 - inspection items: unable to prevent tampering of fuelling equipments

Statistics of the Smoky Vehicles Control Program

	1988	1989	1990	1991 Jan-Sept	1992 Jan-Jun
# of reports received	16418	25145	29032	23623	28665
# of exam. performed	8256	16938	17648	11885	18184
Passing rate	86%	72%	71%	78%	83%
# of licence cancellations recommended	467	1092	1390	561	797
# of vehicles scrapped	208	456	602	110	159

Table 12

47

Comparison of Passing Rate between EPD and Private Centres

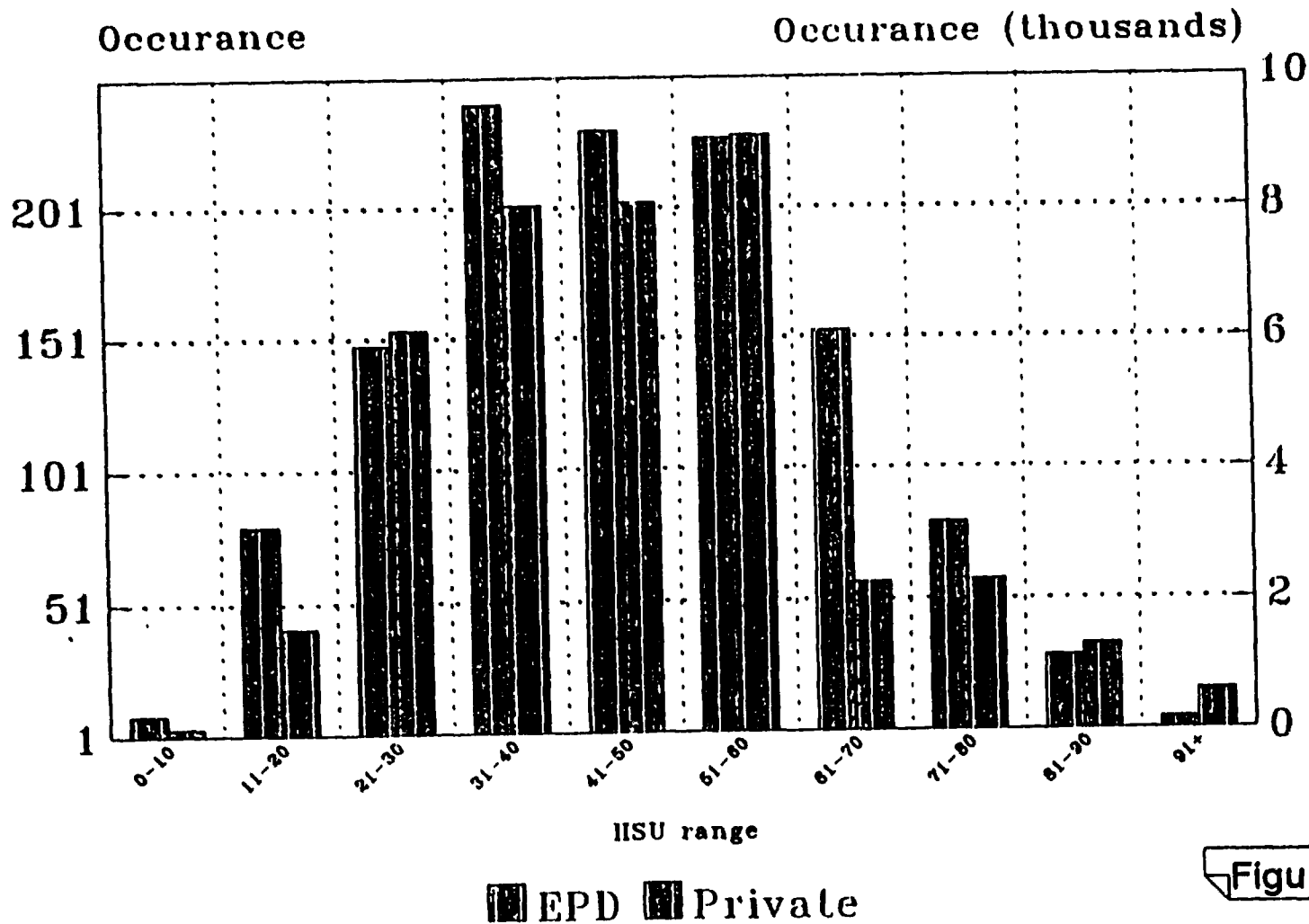

Figure 13

Comparison of Passing Rate between EPD and Private Centres

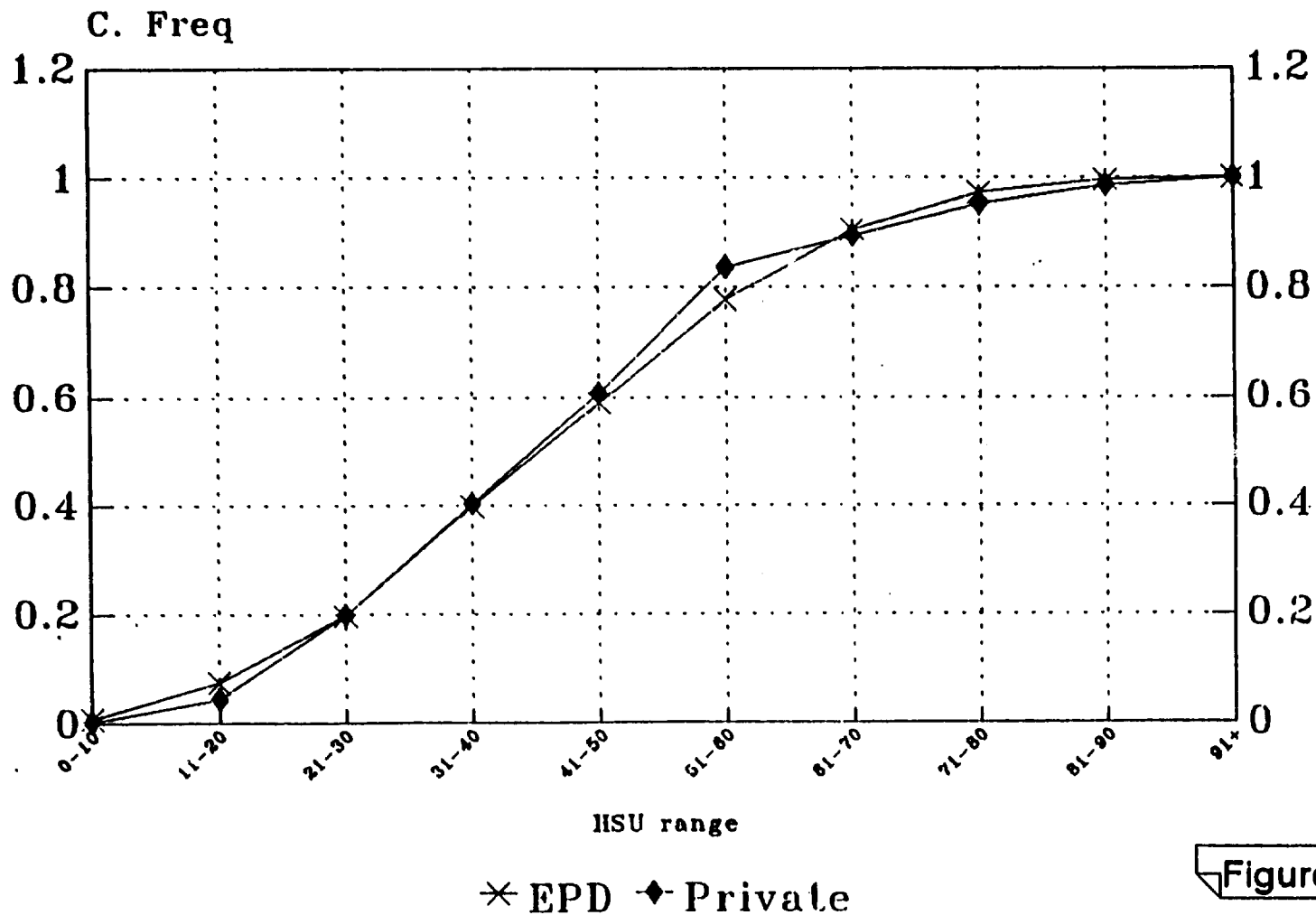

Figure 14

Proposed Motor Vehicle Emission Control Strategy for New Vehicles

Vehicle Class	Approx. Popu. as of Sep 92	Short 92-94	Intermediate 94-97	Long 98 and after
>Petrol				
Car	230000	ULP & TWC	I&M	LEVs
Light Van	4000	ULP & TWC	I&M	LEVs
Light heavy truck	10000	ULP & TWC	I&M	LEVs
Medium heavy truck	minimal	-	-	-
Heavy heavy truck	minimal	-	-	-
Light bus	minimal	-	-	-
Bus	minimal	-	-	-
M/C+ Others	18000	-	-	-
>Diesel				
Car	4800	ULP & TWC	I&M	LEVs
Taxi	17000	Smoke Ctrl. Prog.	91/441/EEC + stringent I&M	ULP & TWC ? (Alt. fuels)
Light Van	20000	Smoke Ctrl.	91/441/EEC + I&M	ULP & TWC ?
Light heavy truck	55000	Smoke Ctrl.	US 90 or equiv.	US 98 or Equv.
Medium heavy truck	27000	-ditto-	-ditto-	-ditto-
Heavy heavy truck	1000	-ditto-	-ditto-	-ditto-
Light bus	4000	Smoke Ctrl.	91/542/EEC + stringent I&M	ULP & TWC ? (Alt. fuels)
Bus	5000	Smoke Ctrl. + Retrofit	US 90 or equiv.	US 98 or Equv.
Others	minimal	-	-	-

All new standards will be complemented with emission warranty
 Alternative fuels: reformulated gasoline, LPG, NG etc.

Chart 9

Growth Trend of Vehicle-kilometre Travelled (VKT)

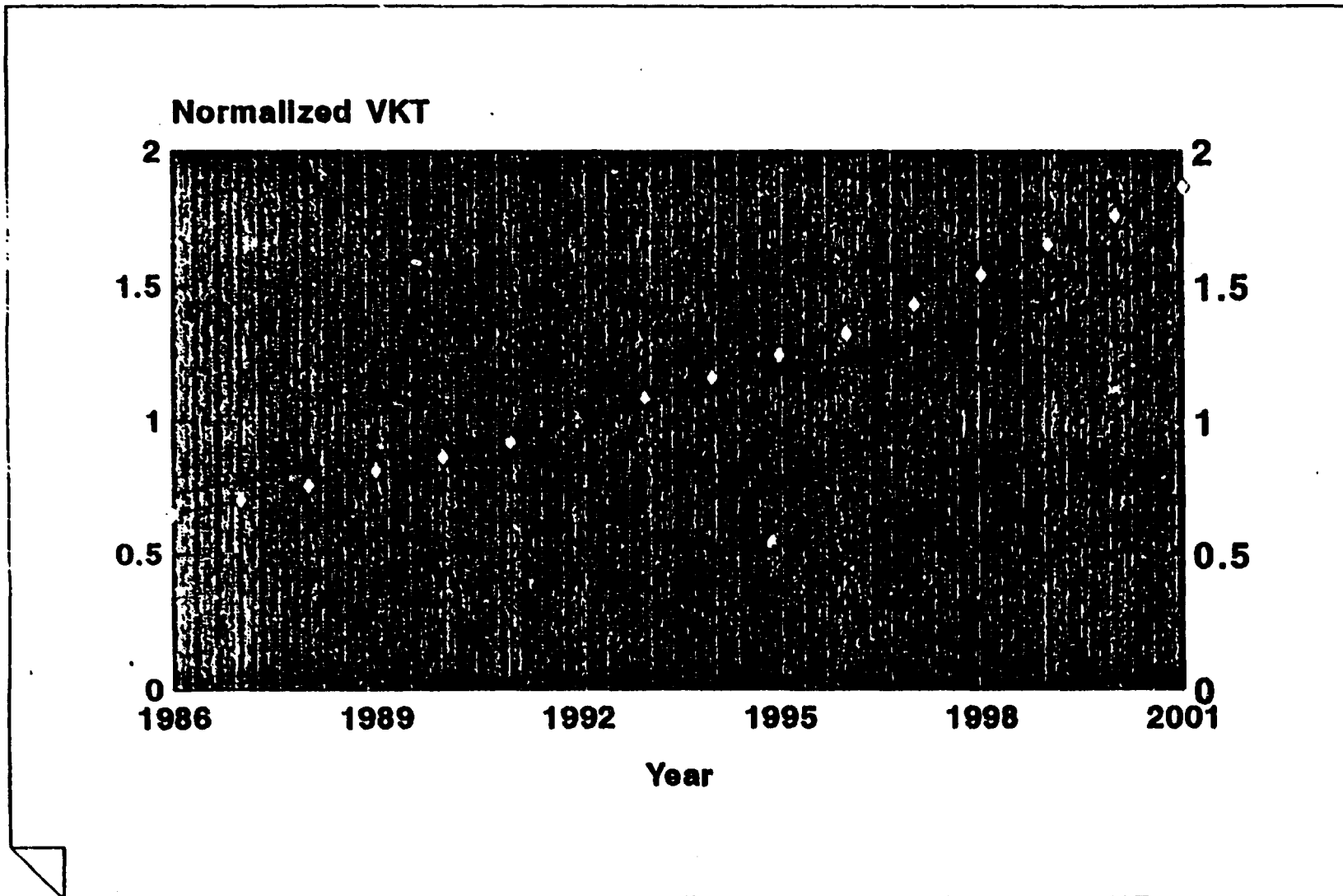

Proposed I&M Concept

- Diesel Vehicles (i.e. Commercial Vehicles)
 - Smoke Control Program. Spotting at HSU 60
 - Test by Free Acceleration method, with accessory load
 - Pass at HSU 40
- Petrol Vehicles (Passenger Cars)
 - Annual emission test after 4 years
 - Test with accessory load
 - Mainly test for converter efficiency
- Petrol Vehicles (Commercial Cars)
 - Annual emission test
 - May require annual rebuild / catalyst replacement

Proposed Motor Vehicle Emission Control Strategy for Current Vehicles

- **Smoke Control Program**
- **Enhanced Smoke Test Procedures**
 - add air-conditioning load
 - check governor setting
- **Bus Retrofit**
 - trap
 - catalyst
 - repower

Proposed Motor Vehicle Emission Control Strategy for New Vehicles

- **Emission Standards**
 - emission level
 - emission warranty
 - tamper proof
- **Reduced reliance on Light Duty Diesel Vehicles**
 - alternative fuels
 - reformulated diesel
 - reformulated petrol
 - LPG
 - NG
 - Electric

Proposed I&M Concept

- Diesel Vehicles (i.e. Commercial Vehicles)
 - Smoke Control Program. Spotting at HSU 60
 - Test by Free Acceleration method, with accessory load
 - Pass at HSU 40
- Petrol Vehicles (Passenger Cars)
 - Annual emission test after 4 years
 - Test with accessory load
 - Mainly test for converter efficiency
- Petrol Vehicles (Commercial Cars)
 - Annual emission test
 - May require annual/rebuild catalyst replacement

COUNTRY PAPER
ON
INSPECTION OF IN-USE MOTOR VEHICLE EMISSIONS
IN INDIA

B. P. Pundir, N. Bagchi & B. Sengupta

Presented at
Expert Group Meeting on In-Use Motor Vehicle
Inspection for Emission Control in the Asia-Pacific Region,
seoul, South Korea
October 20-22, 1992

1.0 INTRODUCTION

The vehicle population in India, particularly of motorcycles, scooters and mopeds has increased at a rapid rate in the last decade. The capital city of Delhi has the largest population of two wheelers of all the metropolitan cities of India. The daily discharge of carbonmonoxide (CO) and nitrogen oxides (NO_x) by transport, industrial and domestic activities in Delhi projected upto the year 2000 are shown in Figs. 1 and 2, respectively. By the end of this century, 1050 tonnes CO and about 300 tonnes of NO_x will be emitted everday in Delhi.

The air quality is being monitored at several points in many major cities. At a busy intersection of roads in Delhi, ambient CO and NO_2 concentrations are shown in Figs 3 and 4, respectively. Although, upto 1990, both Carbon monoxide and Nitrogen dioxide are still within acceptable limits, but if vehicle emissions are not controlled, these may reach the values well above the ambient air quality standards.

Emission standard for vehicles were formulated for the first time in India by the Indian Standard Institution (ISI), now known as the Bureau of Indian Standards (BIS). Indian Standard, 'Smoke Emission Levels for Diesel Engines (IS:8118-1976)' and Indian Standard, 'Emission Limits for Carbon Monoxide for Vehicle Powered by Spark Ignition Engines (IS: 9057 - 1979)' were published in 1976 and 1979, respectively. Based on these standards, the State of Maharashtra amended the Bombay Motor Vehicle Rules in 1984 introducing in-use

vehicle inspection for emission control particularly in Bombay in view of fast growing problem of pollution in this biggest city of India. Later, other Indian states also, adopted the same standards during the period 1986-88.

2.0 EMISSION LIMITS FOR IN-USE VEHICLES

The emission limits for in-use vehicle inspection specified from time to time in India are given in Table-1. IS : 8118-1976 specified separate smoke limits for urban and non-urban areas. The smoke limits were specified both under 'Free Acceleration' and 'Full Load on Road or Chassis Dynamometer'.

Carbon monoxide emissions from petrol vehicles were specified under 'engine idle'. Two different limits were first specified in 1979, viz. (i) For vehicles less than 5 years old and (ii) For vehicles having completed 5 years or 80,000 kms.

Later, both the standards were amended by CPCB and notified by Ministry of Environment and Ministry of Surface Transport, Govt of India (Motor Vehicle Rule 115). The revised limits are also given in Table-1. For the diesel smoke emissions, in the amended standards no distinction is made for vehicles used in urban or non-urban areas. Secondly, for the smoke limits in addition to Hartridge smoke units and Bosch units, the equivalent light absorption coefficient was also specified.

As regards idle CO emissions, the in-use vehicles were grouped in three categories viz (i) 2 and 3 wheelers with

engine capacity $\leq 50 \text{ cm}^3$, (ii) 2 and 3 wheelers with engines other than in category (i) and (iii) the passenger cars, jeeps and light commercial vehicles.

TABLE-1
IN-USE INSPECTION LIMITS OF VEHICLE EMISSIONS IN INDIA

Year		Vehicle Description	Emission	Limits
----- Reg.	Impl.			
PETROL VEHICLES			Idle CO	
1979	1984	< 5 Yr Age		3.0%
		> 5 Yr Age or 80,000 Km		4.5%
1986	1987-88	(i) 2 & 3 Wheelers $\leq 50 \text{ CC}$	-do-	5.0
		(ii) 2 & 3 wheelers > 50 CC	-do-	4.5%
		(iii) Cars, LCV's	-do-	4.0%
DIESEL VEHICLES				
1976	1984 -88	Urban Vehicle	Free Accn	65 HSU
		Non Urban Vehicles	Free Accn	70 HSU
1986	-	All	Free Accn	65 HSU or 2.3 m ⁻¹
			Full Load at 60 to 70% of Rated Engine speed	75 HSU or 5.2 Bosch or 3.1 m ⁻¹

These limits have been now adopted by the different Indian States.

3.0 EMISSION MEASURING EQUIPMENT

Emission equipments specified and being used are given below :

Table-2

EQUIPMENT TYPES FOR IN-USE VEHICLE EMISSION INSPECTION

Pollutant	Test Method	Principle of Measuring Equipment	Typical Makes
Diesel Smoke	Free Accn Acceleration	Light Extinction	Hartidge AVL
		Smoke Impingement on a specified white paper	IIP*
	Full Load	Light Extinction	Hartridge AVL
	Full Load	Filteration	Bosch
CO from Petrol vehicles	Idle	NDIR	Horiba Riken

* This smokemeter although not specified in the standards is being used by several organisations due to simplicity of its operation and low cost and a good correlation with Hartridge smoke meter under free acceleration.

4.0 ORGANISATIONAL STRUCTURE FOR IMPLEMENTATION OF IN-USE VEHICLE EXHAUST EMISSION STANDARDS IN DELHI

The organisation structure for implementation of inuse vehicle exhaust emission standards in Delhi is given in Annexure I. Central Pollution Control Board, Ministry of Environment & Forests & Bureau of Indian Standard are responsible for development of exhaust emission standard and Ministry of Surface Transport after examining the same notified the standard under Motor Vehicle Act. The Transport Authority Department of Delhi Administration is responsible for registration of vehicles and issuing certificate of 'pollution under control' at the time of registration. The inspection team checks the emission from in-use vehicles on road periodically and sometimes at random. These team also give the 'pollution under control' certificate after checking. This team also charges fine if the vehicle under test is not passing the test. The matter may be sent to court if required. The Transport Department also recognises testing agency such as petrol pumps, workshops and garrage where the vehicle owners are required to check their vehicles and get the 'pollution under control' certificate. The motor driving school of this department gives training for driving vehicles and also maintains calibrate and repair the monitoring instrument. The Ministry of Petroleum ensures that the fuel supplies for the vehicle is upto the standard. The office of Deputy Commissioner of police checks the licence, registration, insurance and 'pollution under control' certificate and also maintains traffic discipline. The integrated approach to control vehicular pollution in Delhi is given in Annexure II.

5.0 EMISSION LEVELS FROM INDIAN VEHICLES

In addition to inspection tests being carried out by the concerned State Government Authorities, emission surveys on in-use vehicles have been carried out by the Indian Institute of Petroleum, Dehra Dun at the instance of the Ministry of Environment and Forests, Government of India, the Central Pollution Control Board and other organisations.

5.1 STUDIES BY IIP

Two surveys were carried out by the Indian Institute of Petroleum in 1984 and 1991-92 in Delhi. The number of vehicles monitored in the two surveys are given in Table-3.

Table-3

Number of In-Use Vehicles Surveyed for Emissions

Sl. No.	Vehicle Type	Pollutant	Vehicle Nos	
			1984	1991
1.	Diesel	Smoke (Free Accn)		
(i)	Buses		364	367
(ii)	Trucks		70	591
(iii)	LCV's		74	108
2.	Petrol Vehicles	Idle CO & HC		
(i)	Passenger Cars		253	1092
(ii)	Two Wheelers		194	496
(iii)	Three wheelers		143	254
Total			1098	2908

5.1.1 IDLE CO EMISSIONS

Idle CO emissions from Indian passenger cars as measured in 1984 and 1991 are compared in Figs. 5 and 6. Fig.5 shows, the percent of vehicles giving CO emissions in different ranges i.e. between 0-1%, 1-2%, 2-3% and so on. In Fig.6, commulative frequency distribution for different levels of CO emissions are compared.

During 1984 only 20% cars met 3% idle CO limit while in 1991 about 46% cars met this limit. This is perhaps, largely due to introduction of a large number of new model passenger car after 1985 (production of cars more than doubled after 1985).

Idle CO emissions of two wheelers observed during 1984 and 1991 are compared in Fig.7. It is seen that while in 1985 about 67% of vehicles met the 4.5% idle CO limit, in 1991 only about 57% vehicles met this limit. It may however, be mentioned here that the sample size in 1984 was relatively small.

CO emissions from three wheelers observed in 1984 and 1991 are compared in Fig.8. In 1991 survey no improvements over emission levels of 1984 were observed.

5.1.2 IDLE HC EMISSIONS

Although no limits on idle HC emissions have been specified in India, these emissions were also measured using an NDIR hydrocarbon analyser. These results for the

passenger cars, two and three wheelers are shown in Fig.9 to 11. Idle HC emissions from two and three wheelers were not measured in the 1984 survey. It may be noted that most Indian two and three wheelers are powered by the crankcase scavenged, air-cooled, two-stroke SI engines. Only three makes of motor cycles (one was introduced only in 1992) are currently powered by 4-stroke engines and production of these amounted to only about 8% of the total production of two-wheelers during 1989-90. Of the total population of two-wheeler (approx. 13 million) in the country, 4-stroke engine powered motor cycles are estimated to amount of about 0.5% only.

5.2 DIESEL SMOKE EMISSIONS

Free acceleration smoke emissions measured from diesel vehicles during 1984 and 1991-92 surveys are compared in Fig.12. Practically all diesel vehicles in India are powered by naturally aspirated diesel engines and hence free acceleration smoke test may be considered adequate for inspection of emissions due to ease of its implementation. A slight reduction in smoke emissions is observed during 1991-92 compared to 1984. During 1991-92 about 47% of diesel vehicles surveyed gave smoke below 65 HSU compared to only 38% in 1984.

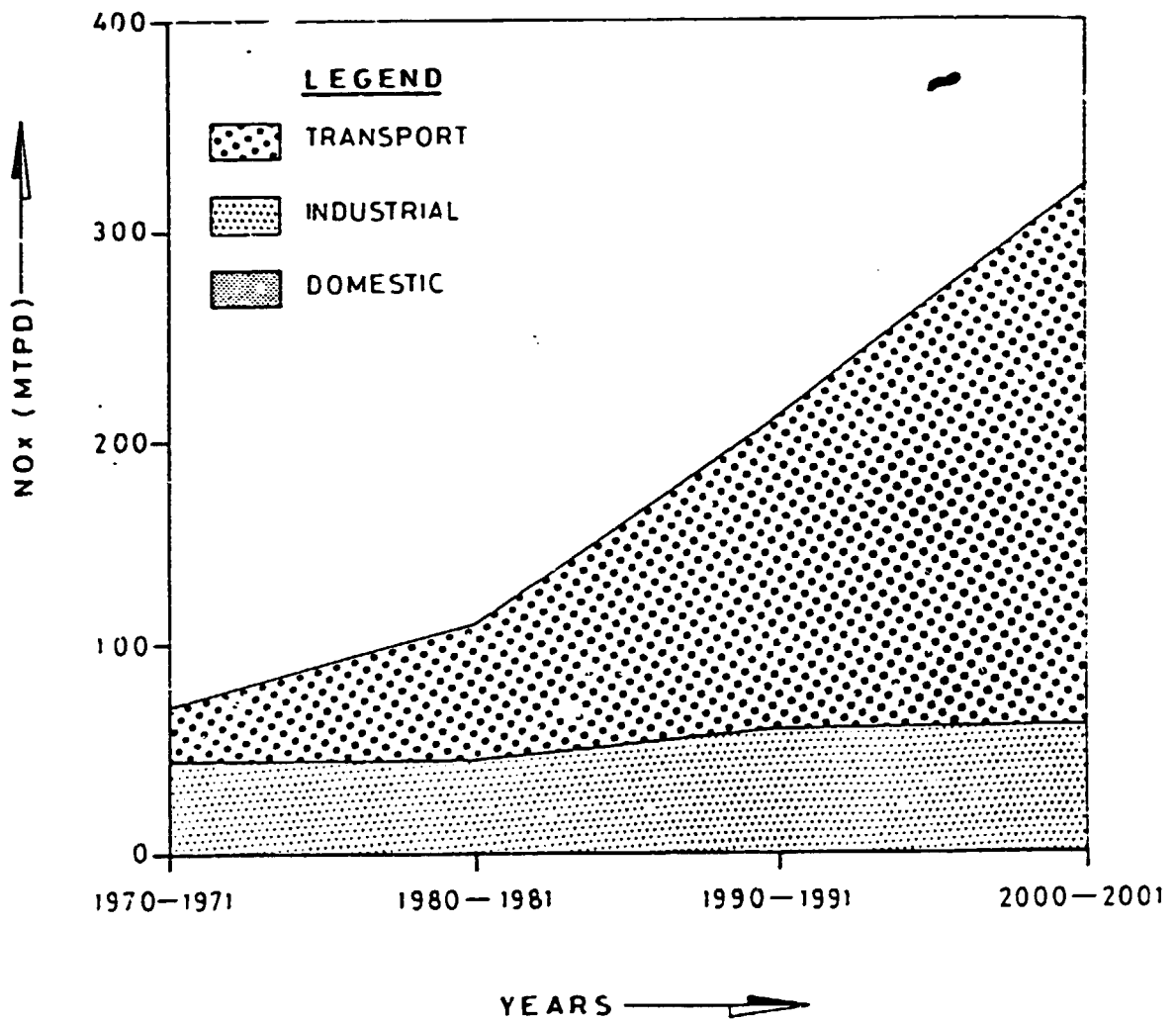

FIG. 1 NO_x EMISSIONS IN DELHI 1971-2001

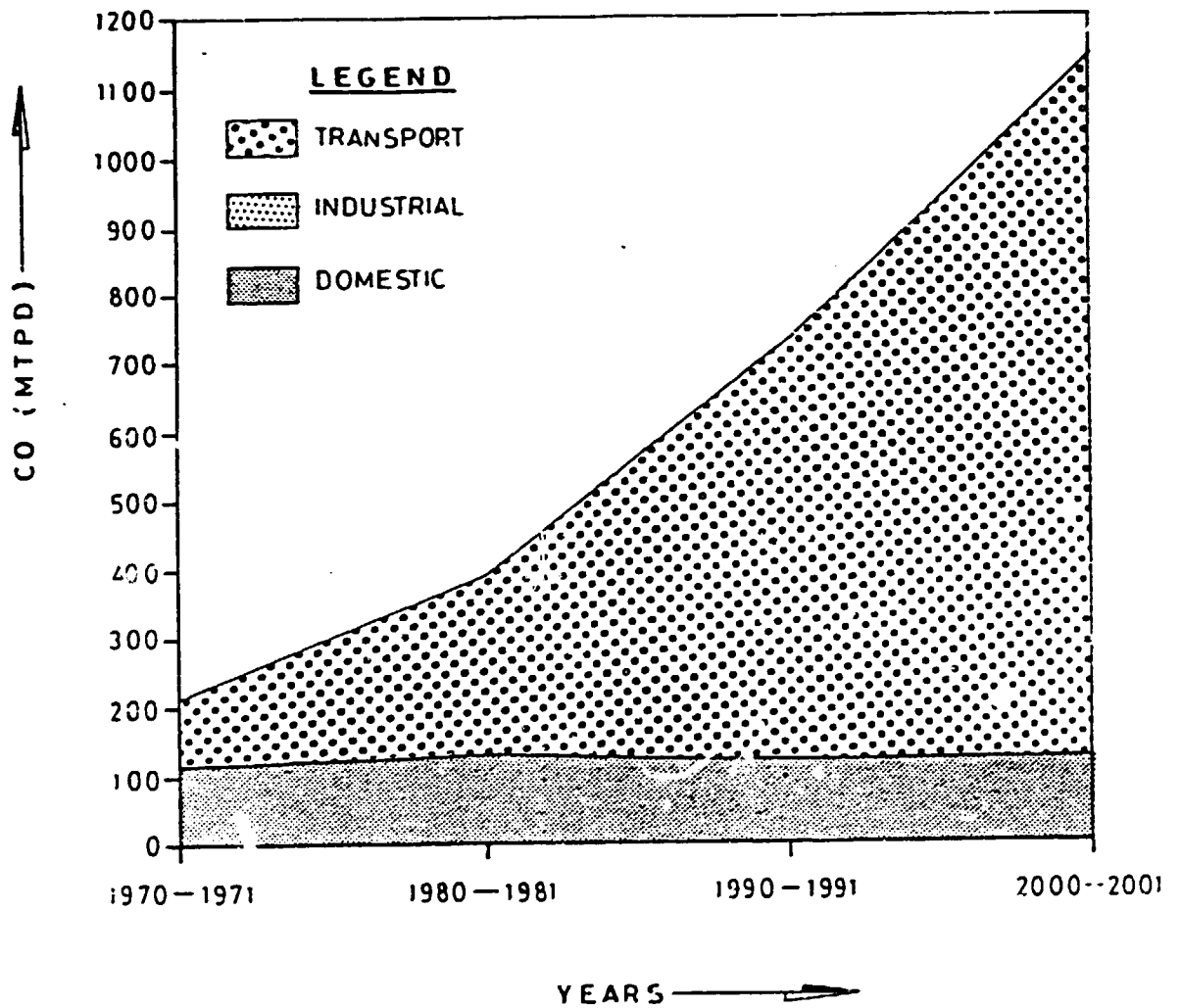

FIG. 2 CO EMISSIONS IN DELHI: 1971-2001

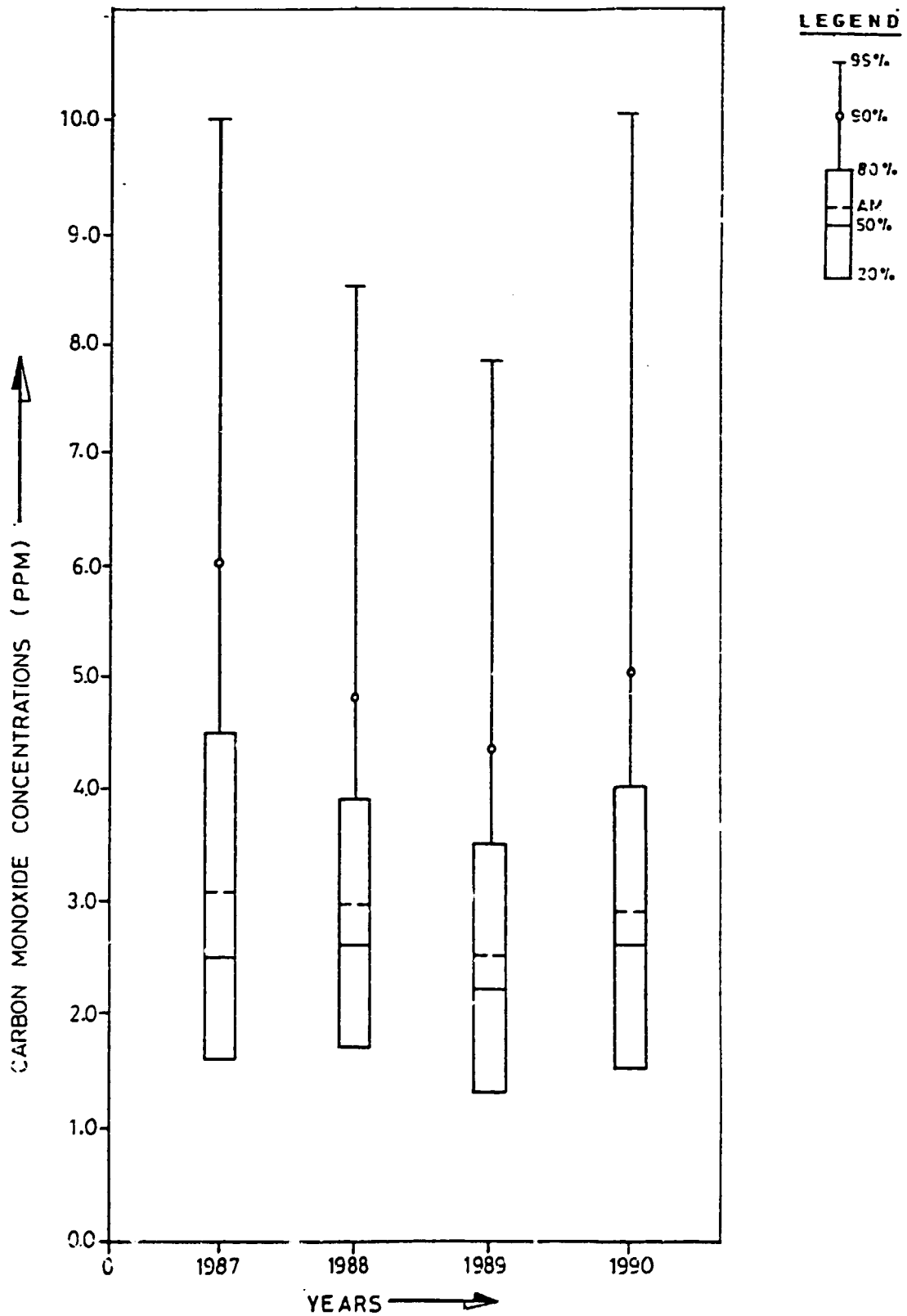

FIG. 3 TREND OF CARBON MONOXIDE CONCENTRATIONS AT INTEGRATED MONITORING STATION, BAHADUR SHAH ZAFAR MARG DELHI FROM JULY 1987 TO DECEMBER 1990

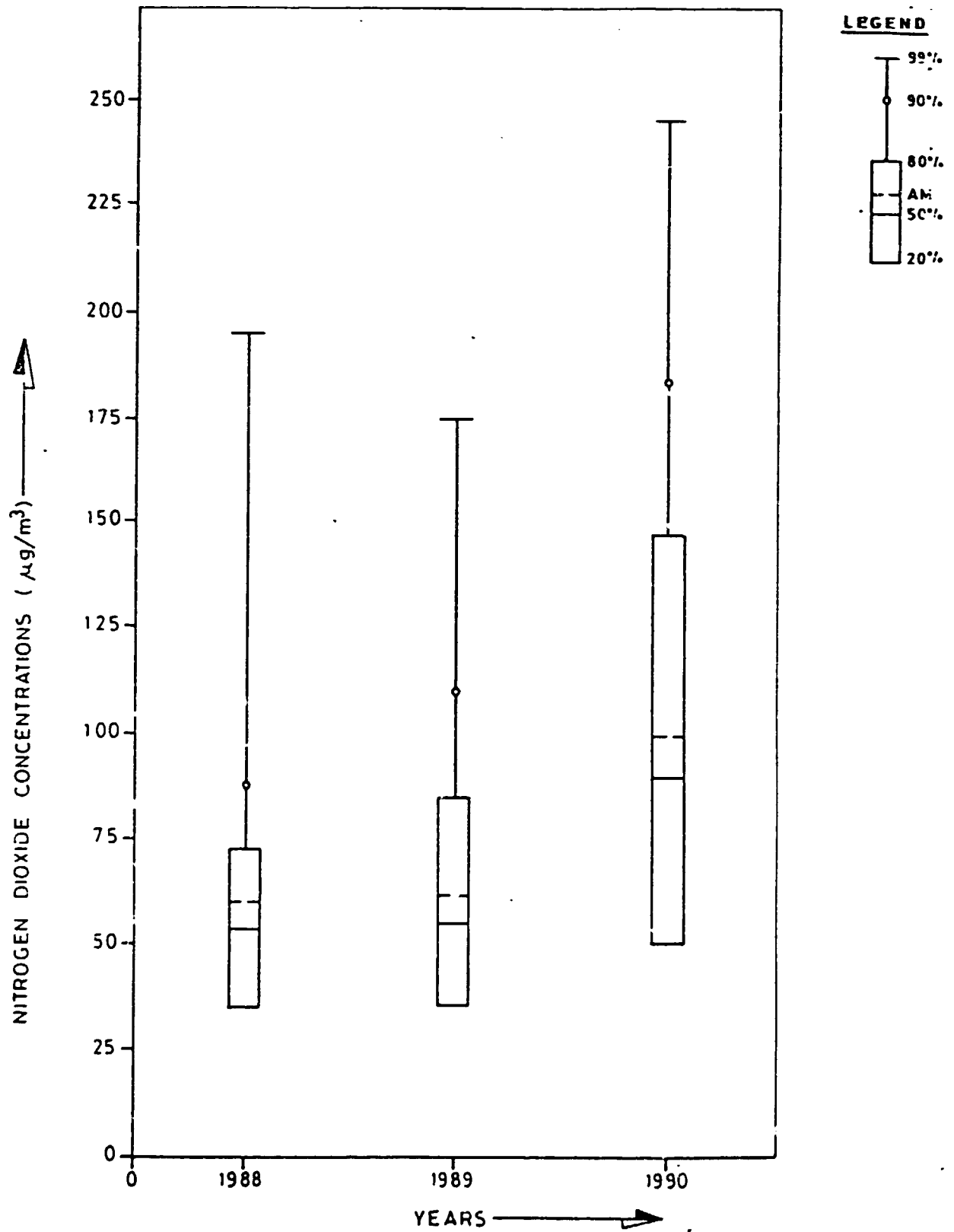

FIG. 4 TREND OF NITROGEN DIOXIDE (NO_2) CONCENTRATIONS AT INTEGRATED MONITORING STATION, BAHADUR SHAH ZAFAR MARG DELHI FROM SEPTEMBER 1988 TO DECEMBER 1990

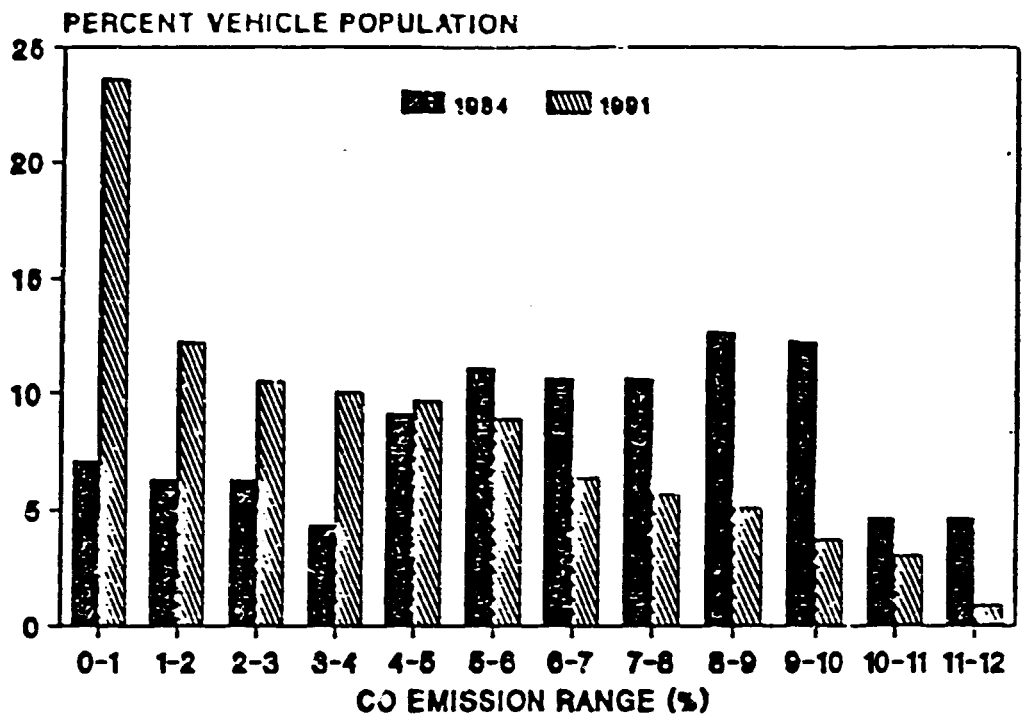

FIG. 5 COMPARISON OF 1984 AND 1991 CO EMISSION TRENDS FOR PASSENGER CARS - FREQUENCY DISTRIBUTION

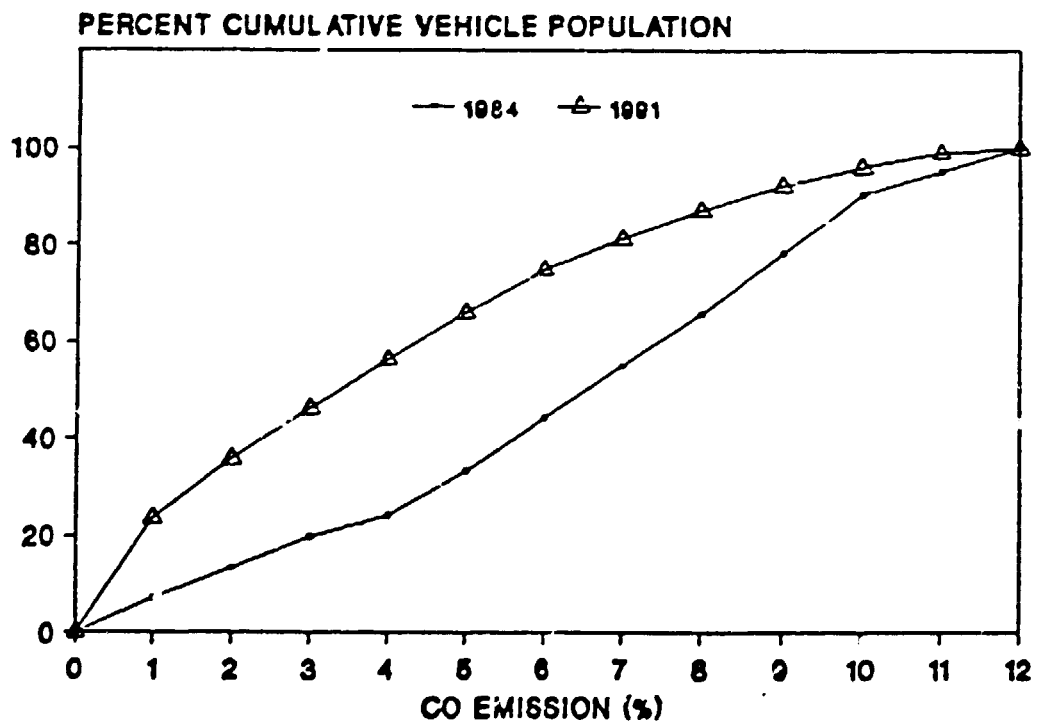

FIG. 6 COMPARISON OF 1984 AND 1991 CO EMISSION TRENDS FOR PASSENGER CARS - CUMULATIVE FREQUENCY DISTRIBUTION

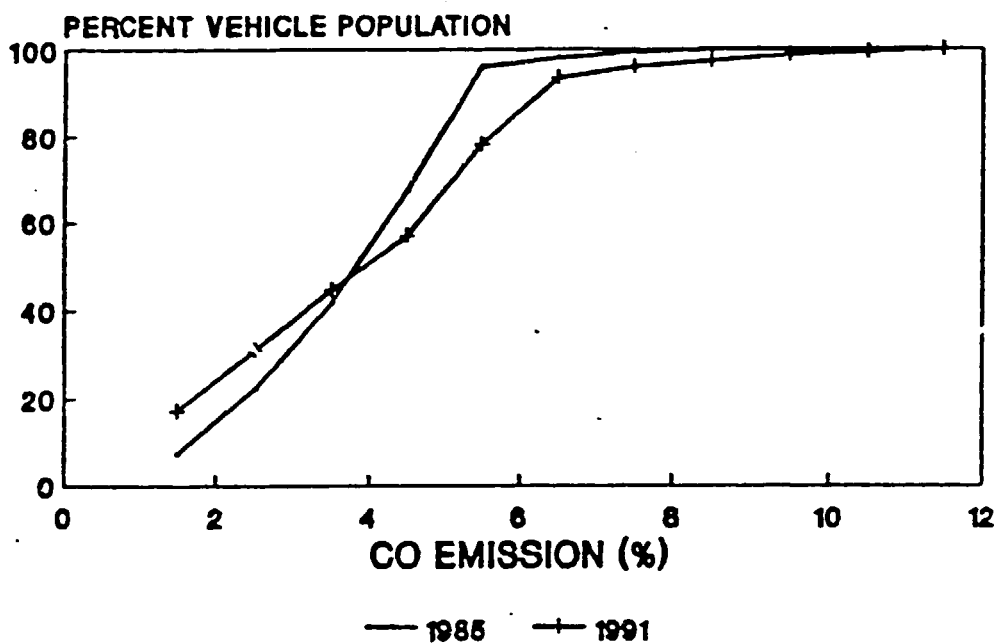

FIG.7 COMPARISON OF CUMULATIVE FREQUENCY DISTRIBUTION OF 1985 AND 1991 CO EMISSION TRENDS FOR TWO WHEELERS

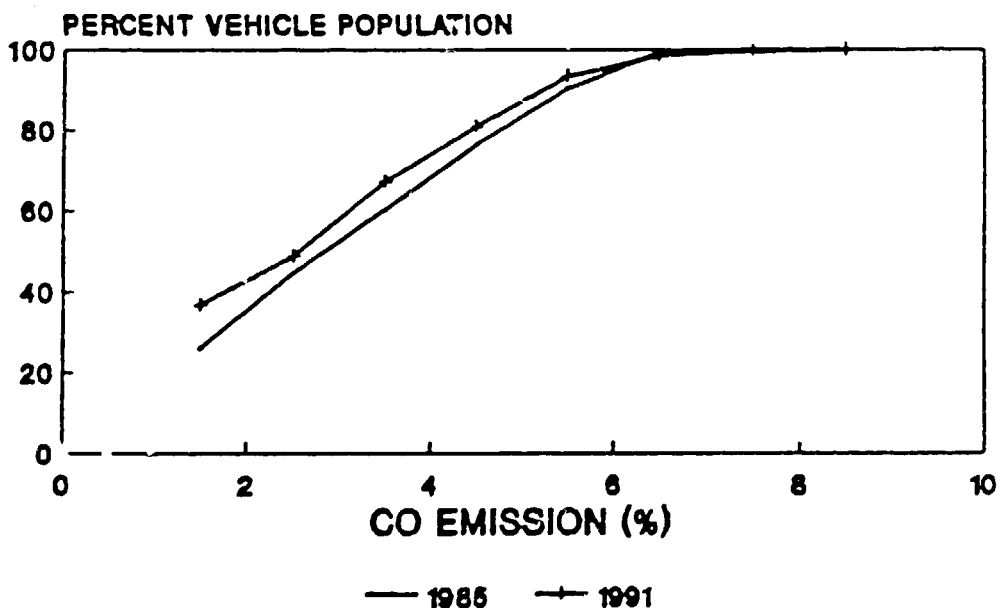

FIG.8:COMPARISON OF CUMULATIVE FREQUENCY DISTRIBUTION OF 1985 AND 1991 CO EMISSION TRENDS FOR THREE WHEELERS

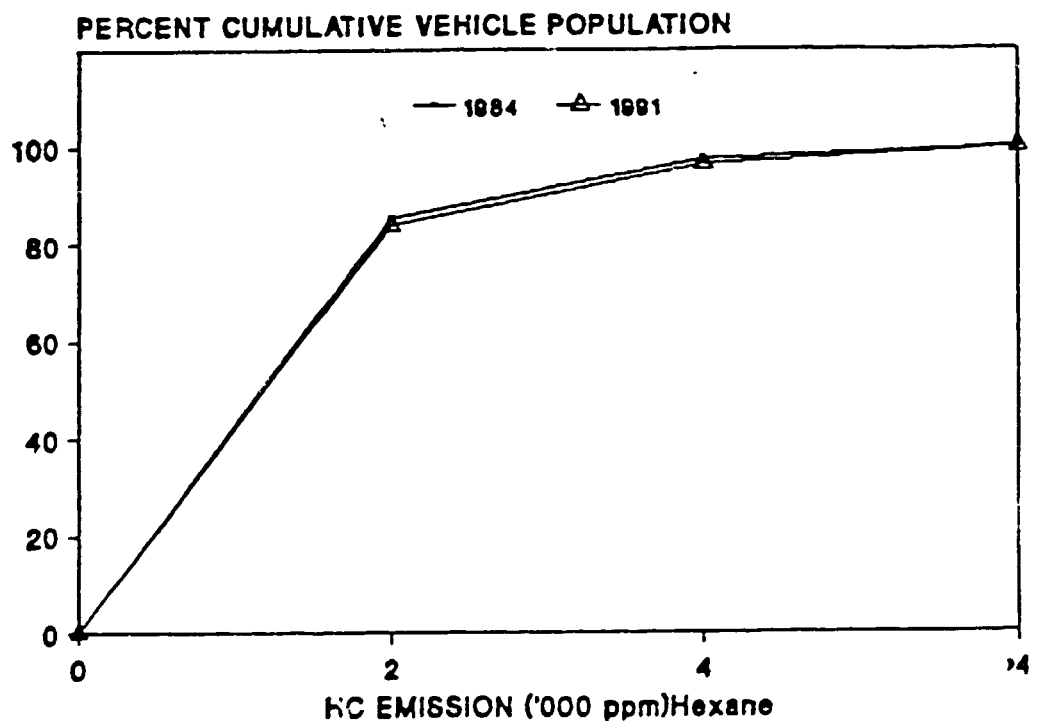

FIG. 9 COMPARISON OF 1984 AND 1991 HC EMISSION TRENDS FOR PASSENGER CARS - CUMULATIVE FREQUENCY DISTRIBUTION

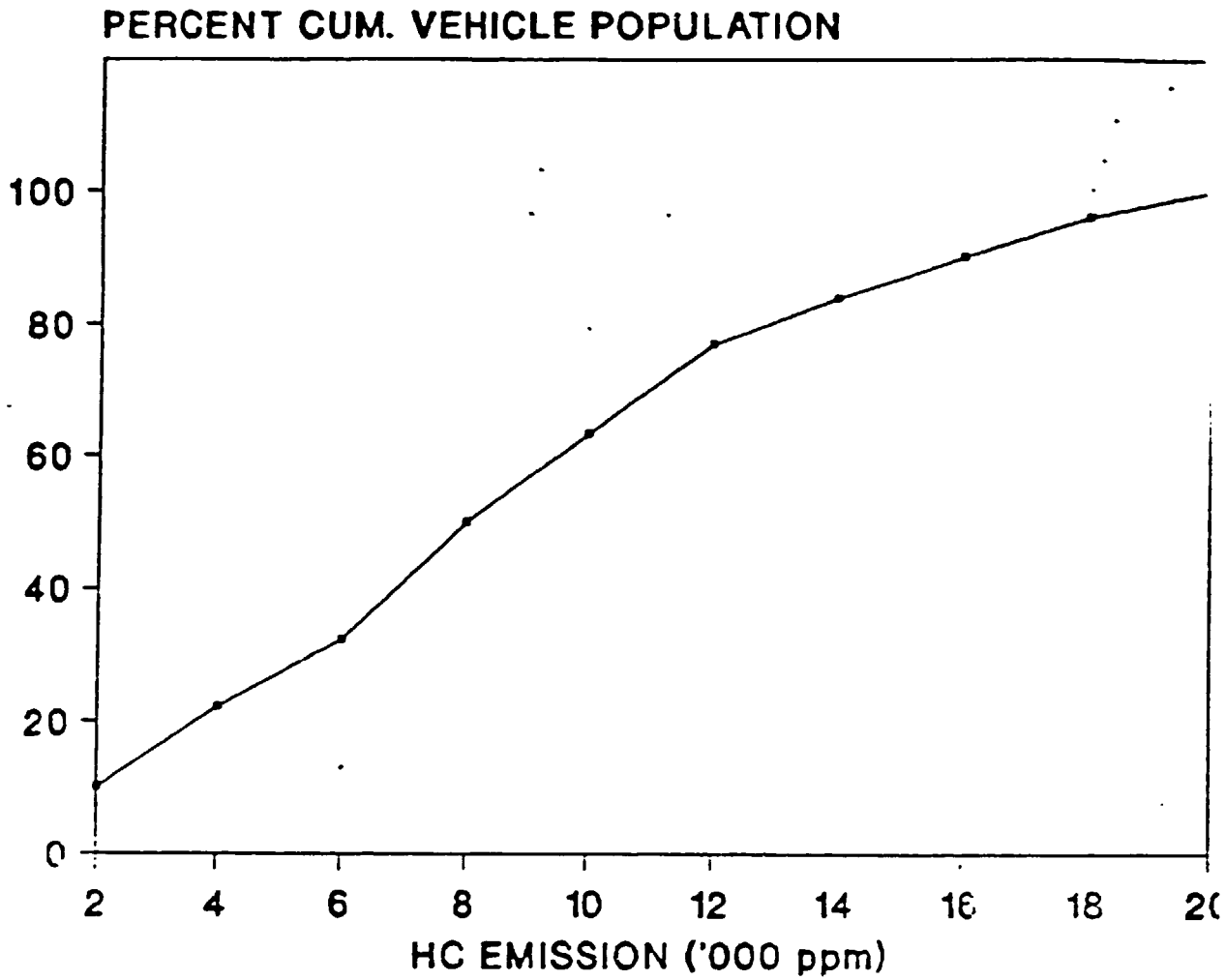

FIG. 10 CUMULATIVE FREQUENCY DISTRIBUTION OF SCOOTERS AND MOTORCYCLES FOR DIFFERENT RANGES OF HC EMISSION LEVELS

PERCENT CUM. VEHICLE POPULATION

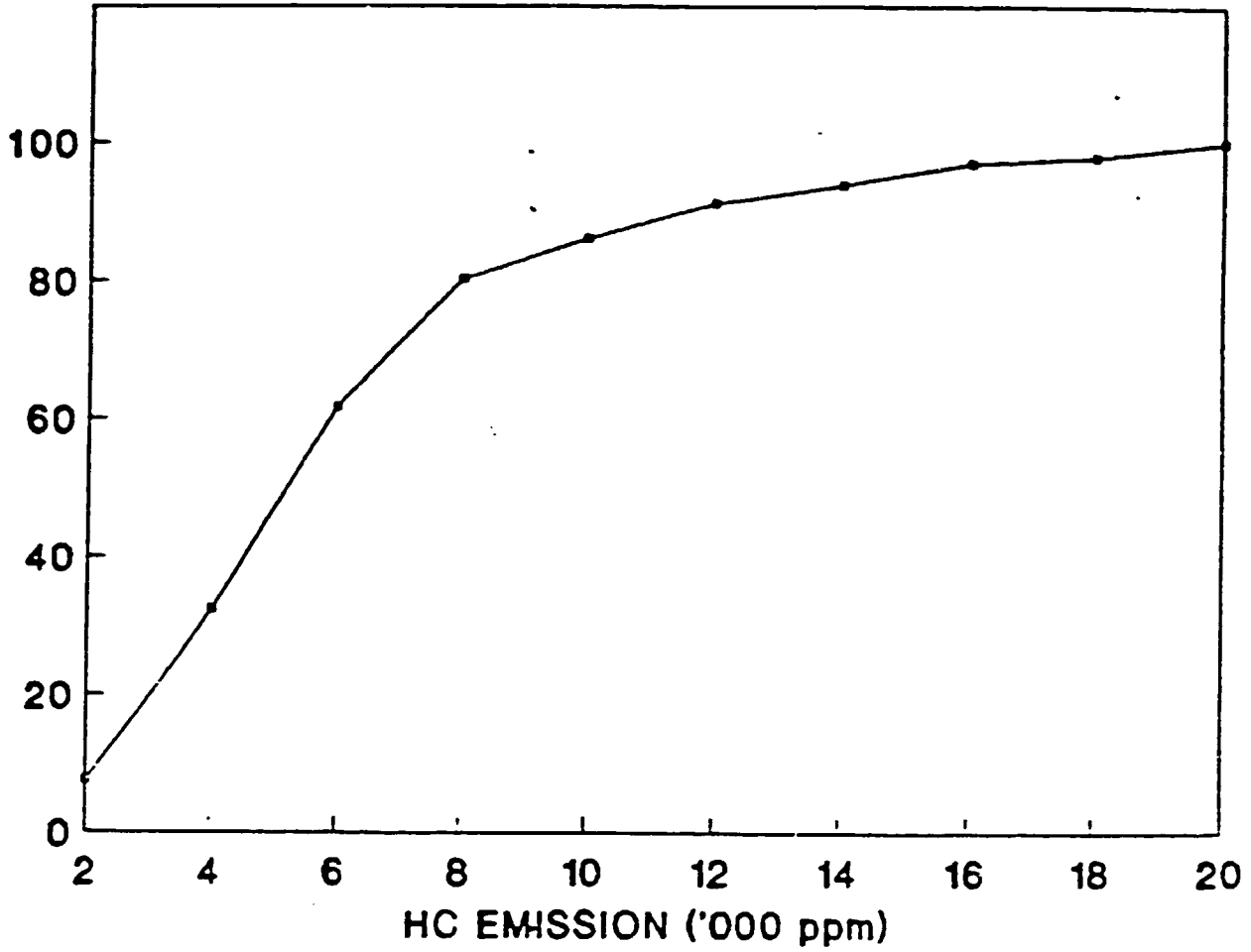

FIG. 11 CUMULATIVE FREQUENCY DISTRIBUTION OF THREE WHEELERS FOR DIFFERENT RANGES OF HC EMISSION LEVELS

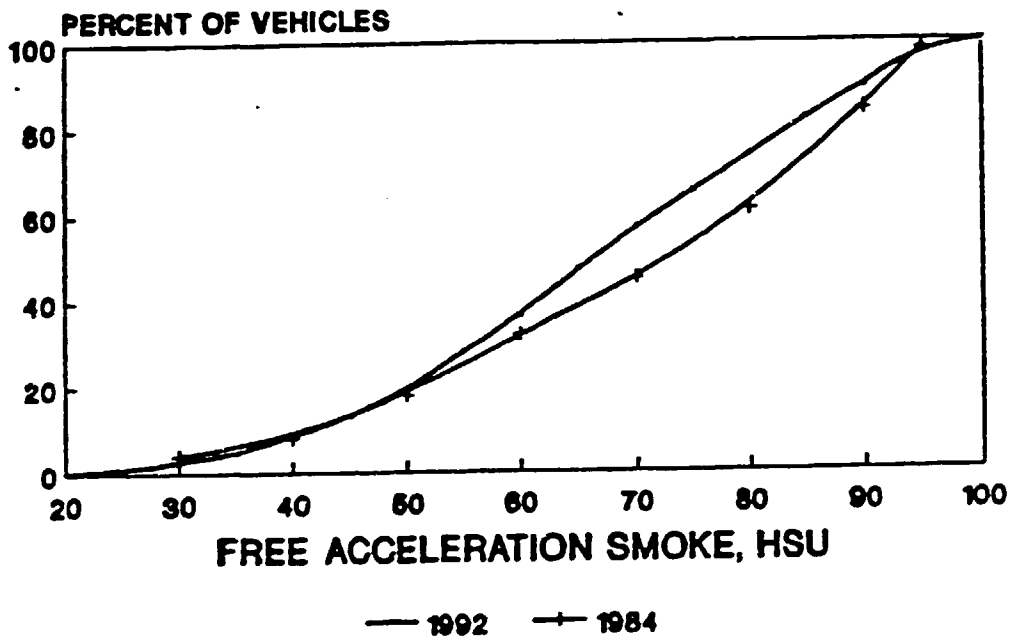
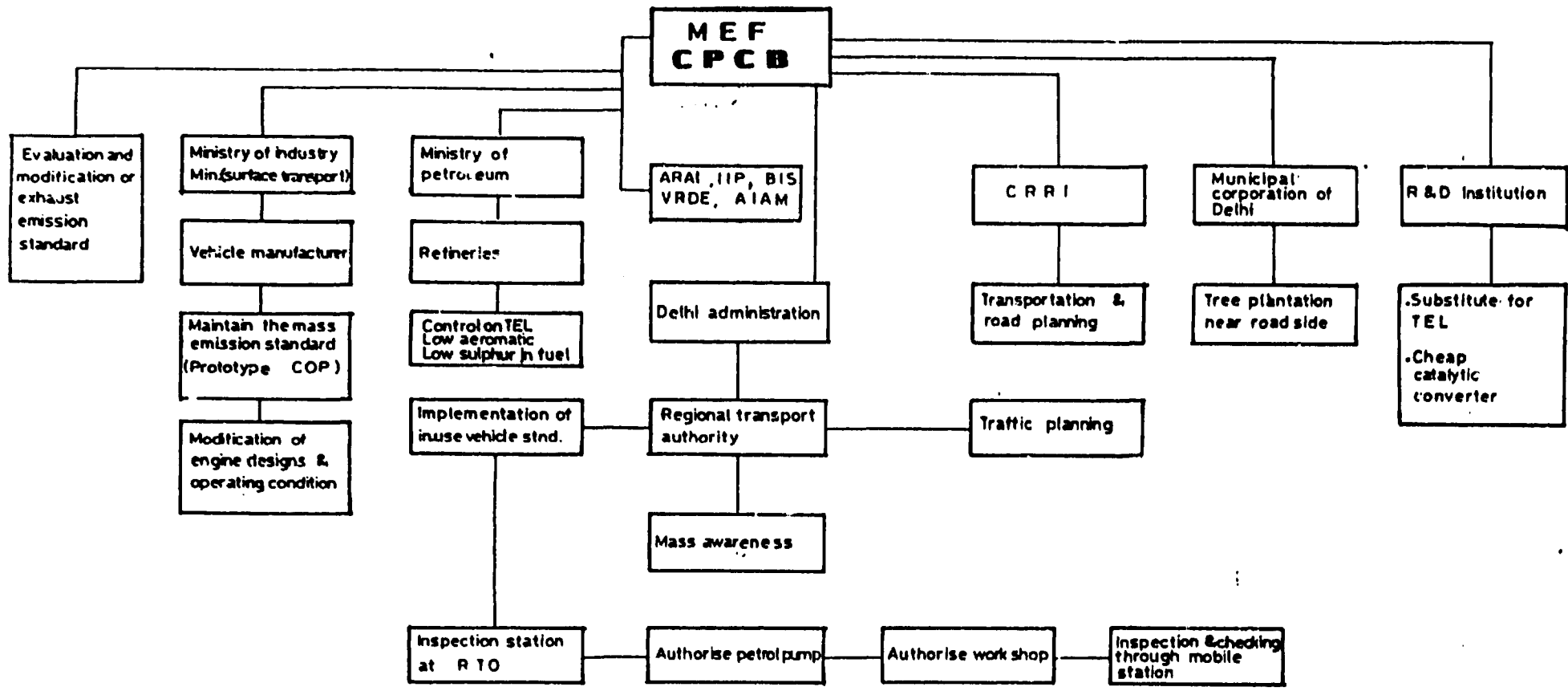
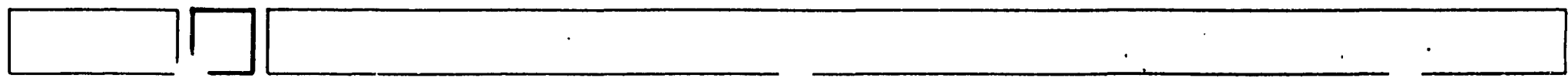
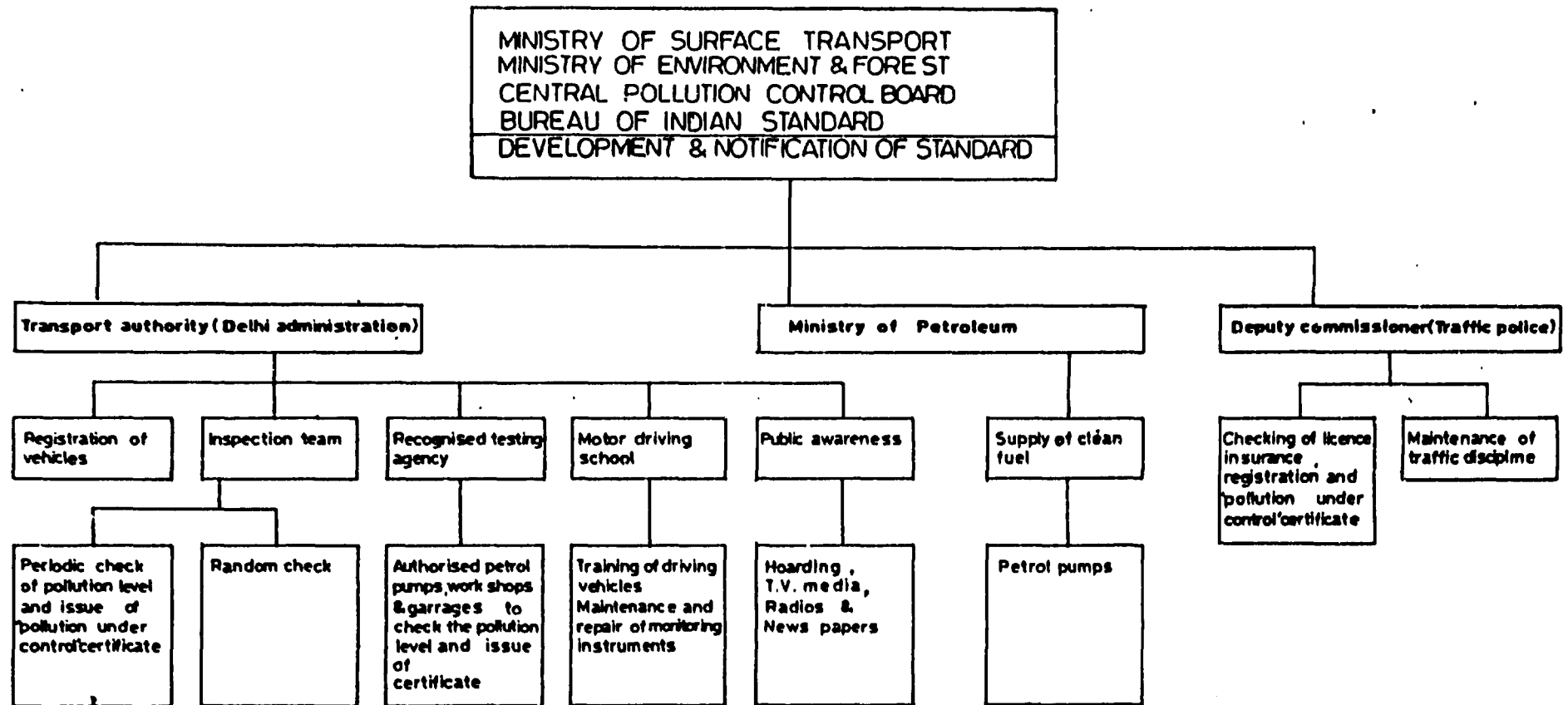

FIG. 12 : COMPARISON OF SMOKE EMISSION TRENDS OF DIESEL VEHICLES - 1991-92 AND 1984 SURVEYS.



INTEGRATED APPROACH TO CONTROL VEHICULAR POLLUTION IN DELHI





**ORGANISATIONAL STRUCTURE FOR IMPLEMENTATION OF
IN-USE VEHICLE EXHAUST EMISSION STANDARD IN DELHI**

**VEHICLE EMISSION STANDARD
AND
CONTROL STRATEGIES IN KOREA**

by

**Kil-Choo (K.C.) Moon
Environment Research Center
Korea Institute of Science and Technology (KIST)**

**Presented
at
United Nations Industrial Development Organization (UNIDO)
in cooperation with
Korea Institute of Science and Technology (KIST)
Seoul, Korea
20 - 22 October 1992**

It is an honor and a special privilege for me to have been invited to represent the UNIDO Motor Vehicle Expert Group at the 1992 Seoul Meeting. In this presentation I address the current standards and control strategies for new and in-use motor vehicle and over all environmental issues. I also outline some of the approaches to environmental policy which are developing within Korea.

INTRODUCTION

Last twenty years, Korea has been experiencing a rapid economic growth with an average annual GNP growth rate of more than 8 %. So Korea is now one of industrializing country with many other Asian countries. As a result, air pollution problems in Korea mainly arise in large cities and industrial complexes. In conjunction with rapid economic development, the population of large cities has increased with an enormous inflow from rural areas, leading to an acceleration of air, water and waste pollution problems in urban areas. For example, the number of automobile in Korea increased to over 5 million in year 1992 from 0.5 million in 1980. The number of automobiles increase more than 2700 vehicles per day in 1992, most of them (about 80%) are passenger cars. Seoul itself has more than 1.5 million automobile including many diesel vehicles. The number vehicle ratio of different fuel using are 55% for gasoline, 44% for diesel and 5% for liquefied petroleum gas (LPG).

Automobile exhaust gas has become one of the major air pollution sources in Korea. The automobile industry and the related industries have also given rise to various environmental problems. In the case of Seoul, the sulfur dioxide and particulate (TSP) concentrations in air have frequently exceeded the air quality standard in winter and summer months, respectively since 1980. Visibility is often poor due to automobile emissions, suspended particulate matters and smog throughout the year in large cities.

REGULATION

Since 1963, Korea has an environment relate law such as the Public Nuisance Prevention Law (PNPL) by the Environmental Sanitation Division in the Ministry of Health and Social Affairs. However, there was no serious pollution and control activities at that time. As a consequence of national growth and industrialization, Korea's environment began to deteriorate. In 1971, the PNPL was revised. However the revised law could not successfully cope with the increasing environmental problems occurring as a result of the rapid economic development.

In 1977, the Comprehensive Environmental Preservation Law (EPL) was founded, replacing the previous PNPL. The EPL was amended in 1979, and authority for implementation transferred from the Ministry of Health and Social Affairs to the Administrator of the Environment Administration. In 1981, the EPL was strengthened through the introduction of a pollution charge system, and the promotion of an environmental pollution prevention fund. However the vehicle emission charge system was not enforced.

This law was amended again in 1986 to strengthen emission standards for ambient. And the vehicle emission standard did not revised until July 1987, especially for diesel vehicles.

For example, the Air Quality Control Law (AQCL) included continuous monitoring of air quality; authorization procedure for air pollutants emission facilities; establishment of emission standards; use of low sulfur fuel and prohibition of solid-fuel use; inspection and improvement orders for automobiles; and establishment of special emissions standards in the special countermeasure areas.

STANDARDS

i) Ambient Air Standard

Current ambient air quality standards of Korea and United State are shown in Table 1. The TSP standard is in process to changing to PM-10.

Table 1: Ambient Air Quality Standards

Pollutant	Averaging Time	Korea (ppm)	U.S.A. (ppm)
SO ₂	Annual Avg.	0.05	0.03
	24-Hours	0.15	0.14
CO	Monthly Avg.	8.0	na
	8-Hours	20	9.0
	1-Hour	na	35
NO ₂	Annual	0.05	0.053
	1-Hour	0.15	na
O ₃	Annual	0.02	na
	1-Hour	0.10	0.12
HC	Annual	3	na
	1-Hour	10	na
TSP for Korea	Annual	150 µg/m ³	50 µg/m ³
PM-10 for U.S.	24-Hours	300 µg/m ³	150 µg/m ³
Pb	Quarter	1.5 µg/m ³	1.5 µg/m ³

ii) Automobile Emission Standard for Gasoline and LPG Vehicles

The vehicle emission becomes one of the major air pollution source since 1980 and Korea becomes automobile manufacturer to export the vehicles. Government set the new vehicle emission standard as similar U.S.A.

In 1990, the emission contribution from motor vehicles in Seoul showed that 56% for CO, 82% for HC 12% for SO₂ and 30% for particulate are from vehicles. Also in 1992 statistical data showed that more than 50% of visibility reduction in Seoul due to the vehicles, especially diesel vehicles.

The following Table 2 shows emission standards for new gasoline and LPG Vehicles. Automobile manufacturers must meet the emission standard to produce new vehicles produce in domestic and export to foreign countries. The test procedure also are shown in the Table 2. As shown in the table, the test procedure and emission standard have been changed since year 1980, and will change in near future, again. For example, the test procedure for passenger car changed in 1987 from 10-Mode to CVS-75 test procedure which is very similar to FTP-75 test procedure of U.S.A..

The emission life (standard) was set for 80,000 km or 5 years after customer purchased. Also the "recall program" was introduced in Korea since 1990. The recall system means if the emission control system failed before the warranted year (80, 000 km or 5 years), the manufacturer must replace or fix the exhaust control system.

iii) Diesel Vehicle Emission Standard and Distribution in Korea

Diesel emission standard for new vehicle is different than gasoline car as other countries. The standard shows in Table 3 including test procedure. Especially the diesel standard is very important for air pollution prevention in Korea, because Korea has more diesel vehicles in percentage than any other developed countries. The diesel in-use vehicle is about 40 percent of total number of vehicle and 55 % and 5% for gasoline, and liquefied petroleum gas (LPG), respectively.

The test procedure for diesel vehicles are similar as gasoline cars except smoke and particulates. Also the test procedure are updated a few times in several years. The particulate exhaust emission standard will be started in 1993 for new vehicles. However the control regulation for in-use vehicles are not tough enough which creates severe air pollution problems.

The one of major visibility problem in Seoul is due to the diesel particulates, because each diesel vehicle emits more than 30 to 50 times particulates than gasoline cars. Also the driving distance of diesel vehicle is about 49% of total distance, and 35% and 16% for gasoline and LPG, respectively. This shows that the pollution contribution by diesel vehicle is much higher than other vehicles. Especially for particulates.

The CO and HC are from gasoline and LPG fuel using vehicles, and NO_x, SO_x and particulates are from diesel vehicles. The HC and CO pollutants can be controlled by catalytic converter, however the NO_x, SO_x and particulates are not well controlled now in Korea. As environmentalist point of view, the exhaust emission control standard for diesel vehicle should be updated to tougher than now, and the basic transportation network system must change to less use diesel vehicles.

Table 2. Emission Standards for New Gasoline and LPG Vehicle

Type of Vehicle	Model Year	Test Procedure	CO	NOx	HC		Smoke (%)
					Exhaust	Evaporative (g/test)	
Small Car ¹⁾	1987. 7. 1.	CVS-75(g/km)	8.0	1.5	2.1	4.0	-
	2000. 1. 1.	CVS-75(g/km)	2.11	0.62	0.25	2.0	-
Passenger Car	1980. 1. 1.	10-Mode(g/km)	26.0	3.0	3.8	-	-
	1984. 7. 1.	10-Mode(g/km)	18.0	2.5	2.8	-	-
	1987. 7. 1.	CVS-75(g/km)	2.11	0.62	0.25	2.0	-
	2000. 1. 1.	CVS-75(g/km)	2.11	0.25	0.16	2.0	-
Light-Duty Truck	1987. 7. 1.	CVS-75(g/km)	6.21	1.43	0.50	2.0	-
	2000. 1. 1.	CVS-75(g/km) ²⁾	2.11	0.62	0.25	2.0	-
		CVS-75(g/km) ³⁾	6.21	1.43	0.5	2.0	-
Heavy-Duty Vehicle	1980. 1. 1.	6-Mode(ppm)	1.6%	2200	520	-	-
	1987. 7. 1.	Transient	15.5	10.7	1.3	4.0	-
		(g/b.hp-hr)					
	1991. 2. 1.	G-13 Mode (g/KWH)	33.5	11.4	1.3	-	-
2000. 1. 1.	G-13 Mode (g/KWH)	33.5	5.5	1.3	-	-	
Motor Cycle	1991. 8. 1.	Idling(%)	5.5	-	1.1/0.45 ⁴⁾	-	-
	1993. 1. 1.	Idling(%)	4.5	-	1.1/0.45 ⁴⁾	-	-
	1996. 1. 1.	Idling(%)	3.6	-	0.45/0.40 ⁴⁾	-	-

1) Less than 800cc of displacement

2) Loaded weight 1.5 ton or less of truck and passenger car capable of seating 15 persons or less

3) Light duty truck except 2)

4) 2 stroke/4 stroke

Table 3. Emission Standards for New Diesel Vehicles

Type of Vehicle	Model Year	Test Procedure	CO	NOx	HC	Particulate	Smoke (%)
Passenger Car	1980. 1. 1.	Full Load	-	-	-	-	50%
	1984. 7. 1.	6Mode(ppm)	980	1000/590 ¹⁾	670	-	50%
	1988. 1. 1.	6Mode(ppm)	980	850/450 ¹⁾	670	-	50%
	1993. 1. 1.	CVS-75(g/km)	2.11	1.25	0.25	0.25	-
	1996. 1. 1.	CVS-75(g/km)	2.11	0.62	0.25	0.12	-
	2000. 1. 1.	CVS-75(g/km)	2.11	0.62	0.25	0.05	-
Light Duty Truck	1980. 1. 1.	Full Load	-	-	-	-	50%
	1984. 7. 1.	6Mode(ppm)	980	1000/590	670	-	50%
	1988. 1. 1.	6Mode(ppm)	980	850/450	670	-	50%
	1993. 1. 1.	6Mode(ppm)	980	750/350	670	-	40%
	1996. 1. 1.	CVS-75(g/km)	6.21	1.43	0.5	0.31	-
	2000. 1. 1.	CVS-75(g/km) ²⁾ CVS-75(g/km) ³⁾	2.11 6.21	0.62 1.43	0.25 0.5	0.05 0.16	- -
Heavy Duty Vehicle	1980. 1. 1.	Full Load	-	-	-	-	50%
	1984. 7. 1.	6Mode(ppm)	980	1000/590	670	-	50%
	1988. 1. 1.	6Mode(ppm)	980	850/450	670	-	50%
	1993. 1. 1.	6Mode(ppm)	980	750/350	670	-	40%
	1996. 1. 1.	D-13Mode(g/KWH)	4.9	11.0	1.2	0.9	40%
	2000. 1. 1.	D-13Mode(g/KWH)	4.9	6.0	1.2	0.25 ⁴⁾ (0.10)	25%

1) Direct Injection/Indirect Injection

2) Loaded weight 1.5 ton or less of truck and passenger car capable of seating 15 persons or less

3) Light duty truck except 2)

4) () City Bus

iv) Fuel Quality Standard

The fuel quality standard followed the ambient air quality standard, especially the sulfur content in fuel. The detailed standard shows in Table 4. Moreover the lead will not be contained in gasoline from 1993, and phosphorous has also been introduced in the fuel for a function of catalytic medium.

As shown in the table, the regulation for diesel fuel will be reduced to 0.2% of sulfur in 1993 from 0.4%, and to maximum 0.1% in 1996. However the sulfur contents in diesel fuel is still too high to compare the other developed countries.

Table 4: Standard for Automobile Fuel Additives

Model Year		Feb. 2, '91	Jan. 1, '93	Jan. 1, '96
Fuel Type of Automobile		Dec. 31, '92	Dec. 31, '95	
Gasoline	Aromatics Compound(Vol. %)	-	Max. 55	Max. 55
	Benzene(Vol. %)	-	Max. 6	Max. 5
	Lead(g/liter)	Max. 0.013	Max. 0.013	Max. 0.013
	Phosphorous (g/liter)	Max. 0.0013	Max. 0.0013	Max. 0.0013
	Oxygen (Weight %)	-	Min. 0.5	Min. 0.5
Diesel	10% Residual Carbon (%)	Max. 0.20	Max. 0.20	Max. 0.15
	Sulphur (Weight %)	Max. 0.4	Max. 0.2	Max. 0.1

The oil for 2-stroke engines standard does not established in Korea, yet. National Institute of Environment Research (NIER) of the Ministry of Environment is planning it now. However the number of 2-stroke engine in-use (small size motobike) is relatively small percentage in Korea. The 2-stroke engine using bike is about 20% of total number of the bike, and it is usually smaller than 150 C³ engine size. Also the tendency of using bike becomes to 4-stroke engine in Korea which means prefers large bikes.

INSPECTION AND MAINTAINS PROCEDURE

The inspection and maintains program for in-use vehicle was adapted a long time ago in Korea. However, the emission standard for in-use vehicle was not well classified until 1984, and the standard was classified for different vehicles in 1987. The detailed exhaust emission permissible standards are shown in below Table 5.

Table 5. Emission Standards for In-use Cars

Type of Vehicle	Pollutants	CO	IIC	Smoke	Remark
Gasoline and LPG Cars	1979 - 1984. 6	4.5%	-	-	
	1984. 7 - 1987. 7	4.5%	1200ppm	-	
	As of July 1987.	4.5%	1200ppm	-	Old model car
		1.2%	220ppm	-	New model gasoline car
		1.2%	400ppm	-	New model LPG car
Diesel Cars	1979 - 1990	-	-	50%	
	As of Jan.1991	-	-	40%	

* Test Method : CO / HC : Idling (NDIR)
Smoke : Free Acceleration (opacity)

Table 6 shows interval of inspection. The interval of inspection for in-use vehicle depends a type of motor vehicle and used age. For example, private passenger cars are inspected every 2 years until 10 year old, after that it should be inspected every year.

Table 6. Types of Motor Vehicle Subjected to Inspection and the Interval of Inspection

Classification		Period of Validity of Motor Vehicle Inspection Certificate
Private Passenger Cars	Used vehicles less than 10 years	2 years
	Used vehicles not less than 10 years	1 year
Commercial Passenger Cars		1 year
Light Duty Trucks	Used vehicles less than 2 years	1 year
	Used vehicles not less than 2 years	6 months
Other Motor Vehicles	Used vehicles less then 2 years	1 year
	Used vehicles not less than 2 years	6 months

Also the in-use vehicle can be inspected randomly on roadside for exhaust emission and maintenance records by government inspection team. The inspection team belongs to an inspection and maintenance branch of the Ministry of Environment or special inspection team of city or/and local government, and prosecuting authorities. The roadside inspection penalty provision is shown in Table 7.

Table 7. Penalty Provision of Roadside Inspection Program

Pollutant	Model Year	Kind of Fuel	Model Year	Standards	Penalty Provision		
					Maintenance Order	Suspension of Operation	Fine
Smoke	All Model	Diesel Fuel	All Vehicles	40%	4%	60-70%: 1day 70-80%: 2days Min. 80%: 5days	4%
CO	87 Model Year or Old	Gasoline and LPG	All Vehicles	4.5%	4.6%	Excess % of standards - 400-500% : 2days - min. 500%: 3days	9.1%
	88 Model Year or New	Gasoline and LPG	Passenger Cars	1.2%	1.3%		4.5%
			Others	4.5%	4.6%		9.1%
HC	87 Model Year or Old	Gasoline and LPG	All Vehicles	1200ppm	1201ppm		- min. 500%: 3days
	88 Model Year or New	Gasoline	Passenger Cars	220ppm	221ppm	881ppm	
		LPG	Passenger Cars	400ppm	401ppm	1601ppm	
		Gasoline and LPG	Others	1200ppm	1201ppm	4801ppm	

If roadside inspection shows exceed than the exhaust permissible standard. Then the vehicle is subject to maintenance order with or without accusation. The driver of the accused vehicle is fined to the maximum of 2,000,000 won (about U.S. \$2500) for it. In case of a company owned vehicle, both the owner and the driver of the vehicle are fined to the maximum of 4,000,000 won (about U.S. \$5000) in total.

In addition to the roadside inspection, the emission effects on air pollution and health risk were educated to the drivers and mechanics in regular base . Also government gives many public seminar and education in order to reduce the smoke emission. However the government uses diesel vehicles as a basic public transportation system and not enough enforcements are exercising.

The roadside check can be performed in two different ways such as actual measurement and video tapes methods. The detailed enforcement procedures show in Figures 1 and 2 for actual measurement and video tapes inspection, respectively.

PUBLIC ENVIRONMENTAL EDUCATION

Public awareness is essential for the improvement and maintenance of environmental quality. Basic policy on public awareness of the Korean government is to help establish ethical base relating to nature conservation and environmental protection.

The efforts to increase public awareness of the value of nature began in the mid-1970's. In 1978, the government instituted a "Charter for Nature Conservation", and invested on promoting the development of a native-wide nature conservation movement.

Environmental education is essential for the heightened environmental consciousness. However, the importance of environmental education had been largely neglected in Korea. After the air was polluted, the government and the higher education sector were concerned the public education to restore the clean environment.

Enforcement Procedure for Accusation

Figure 1: Roadside

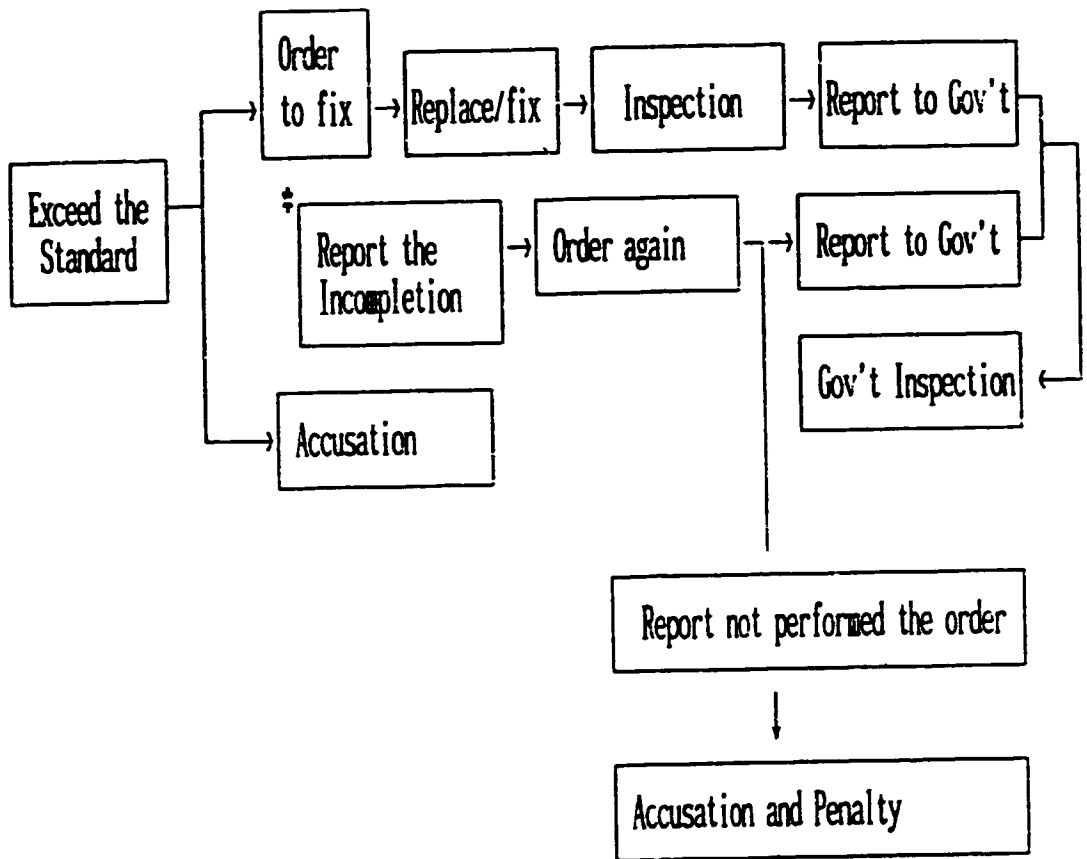

* Do not Performed the Order

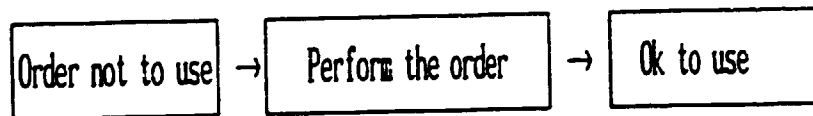
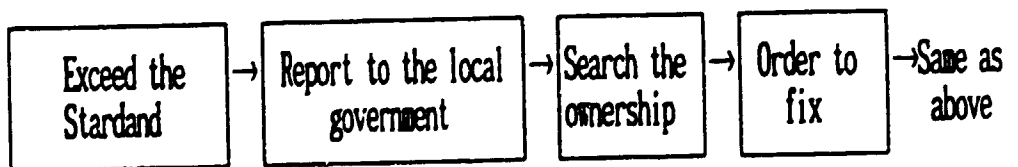

Figure 2: Video Inspection



FUTURE AUTOMOBILE EMISSION AND CONCLUSION

As already stated in earlier, Korea has been developed very rapid growing rates in several years including automobiles without proper pollution prevention policy. As a result, one of the major air pollution source is from vehicle emission, such as 50% of the visibility reduction metropolitan area of Seoul due to the diesel particulates.

As shown already in above, Korea has well developed emission standard and regulation for in-use and new vehicles. However, the enforcement for the violated vehicles and basic transportation policy are not well planned, especially using diesel vehicles for public transportation. The diesel vehicles which occupied more than 40% of total travel miles, and the most of the vehicles are large and heavy duty engines.

In order to reduce vehicles emission problem, the government must change the transportation system and basic fuel supply policy, such as apply same or more amount of tax on diesel fuel. Actually the diesel fuel is applied very low tax to compare gasoline, so the price of the diesel is less than half of the gasoline in Korea. Also the government must develop control technology for particulate & gases, and improve the quality of fuel and reinforce the inspection practices of in-use vehicle.

Thank you for your attention and I hope you have very good time in Korea.

COUNTRY REPORT FOR EXPERT GROUP

MEETING ON IN-USE

MOTOR VEHICLES INSPECTION

FOR EMISSION CONTROL

IN THE ASIA-PACIFIC REGION

20 OCTOBER 1992 TO 22 OCTOBER 1992

I INTRODUCTION

1.1 Singapore consists of the island of Singapore and some 58 islets within its territorial water. The total land area, including the islets is about 639 square kilometres. The main island is about 42 km in length and 23 km in breadth.

1.2 Due to its size, land is a very scarce resource in Singapore. Land-use is therefore very intensive. The proportion of land set aside for roads and related uses in Singapore is one of the highest in this region.

1.3 The population is about 2.76 million growing at an annual rate of about 2.1 percent. Population density is about 4323 persons to a square kilometre.

1.4 Singapore's per capita Gross National Product (GNP) has grown rapidly from S\$9,854 in 1981 to S\$20,031 in 1991.

1.5 The development of transport infrastructure played an important role in the overall economic development of Singapore.

II TRANSPORTATION IN SINGAPORE

2.1 By virtue of its small size, Singapore is a highly urbanised city-state. Hence, road transport is the major mode of transport within Singapore. The Registry of Vehicles (ROV), a department under the Ministry of Communications, is the authority in charge of registration and licensing of all vehicles in Singapore.

2.2 Motor Vehicle Population

At the end of 1991, there are about 559,300 motor vehicles registered with the ROV. Of these about 285,300 are cars and stationwagons, 121,200 are motorcycles and scooters, 120,800 are goods vehicles and 22,000 are public service vehicles (please see Annex 1 for details). Annex 2 shows the motor vehicles by type of fuel used.

III MOTOR VEHICLES EXHAUST EMISSION CONTROL IN SINGAPORE

3.1 Singaporeans have a relatively wide range of choice of make and models of vehicles for their transport needs. There are no import restriction and the vehicles in Singapore are mainly imported from Europe and Japan. However, all vehicles must be registered with the ROV before they can be used on the roads.

3.2 The ROV assists the Ministry of the Environment (ENV) in vehicular pollution control. ROV adopts a 3-pronged approach to ensure that all vehicles comply with the local rules and requirements including the exhaust emission standard set by the ENV. Compliance of these requirements is ensured through:-

- a) Type Approval Inspection
- b) Periodic Inspection
- c) Enforcement Inspection

3.3 Type Approval Inspection

3.3.1 All new models of vehicles imported into Singapore must pass a type approval inspection at ROV before they can be registered for use on our roads. The type approval inspection ensures that these vehicles meet constructional and safety standards including exhaust emission standard set by the ENV.

3.3.2 The current exhaust emission standards and the requirement of fuel used for all vehicles are as follows:-

3.3.2.1 Petrol-driven vehicles except motorcycles and scooters

- i) With effect from 1st Jul 91, all petrol-driven vehicles are required to be able to use unleaded petrol before they can be registered for use in Singapore.

- ii) With effect from 1st Jul 1992, all petrol-driven vehicles must comply with the ECE 83 or the Japanese Safety Regulations for Road Vehicles (Article 31) emission standards before they can be registered for use in Singapore. A more stringent revised version of the ECE 83 standard known as the consolidated ECE 83 standard (Directive 91/441/EEC) is currently being considered by the ENV to replace the ECE 83 emission standard.

3.3.2.2 Diesel-driven vehicles

- i) With effect from 1st Jan 1991, all diesel-driven vehicles must comply with the UN/ECE Regulation 24.03 before they can be registered for use in Singapore.

- ii) With effect from 1st Jan 1992, all used diesel-driven vehicles must comply with the UN/ECE Regulation 24.03 before they can be registered for use in Singapore.

3.3.2.3 Motorcycles and scooters

- i) With effect from 1st Jul 1991, all motorcycles and scooters must be able to use unleaded petrol before they can be registered for use in Singapore.
- ii) With effect from 1st Oct 1991, all motorcycles and scooters must comply with the United States Code of Federal Regulation (40CFR 86.410-80) emission standard before they can be registered for use in Singapore.

3.4 Periodic Inspection

All in-use vehicles are required to undergo compulsory mechanical inspection periodically. This is to ensure that vehicles on public roads are maintained properly in a roadworthy condition and that they do not pollute the environment. The stationary exhaust emissions are checked during these inspections. The schedule of inspection is given in Annex 3.

3.5 Enforcement Inspection

3.5.1 Enforcement inspection is conducted daily by spot checking on vehicles running on the road. This will ensure that the vehicles are being maintained regularly and not only during the periodic inspection.

3.5.2 The enforcement standard and penalties imposed on smoky diesel vehicles are as follows:-

<u>Smoke Level</u>	<u>Penalty</u>
a) 51 - 70 HSU	Fines (Owner \$100; Driver \$100)
b) 71 - 85 HSU	Fines (Owner \$100; Driver \$100) Vehicle prohibited from the road until faults are rectified.
c) 86 HSU and above	Owner and driver will be charge in court. Vehicle prohibited from the road until faults are rectified.

IV Conclusion

4.1 Vehicular exhaust emission have a significant impact on the ambient air quality of Singapore. To improve our ambient air quality, we need to keep abreast with the latest developments in automotive technology and vehicular exhaust emission controls and to implement suitable control measures.

4.2 Besides imposing legislative measures such as setting of emission standards and carrying out enforcement action, educating the owners on the proper usage and maintenance of their vehicles is also important. It is hoped that with our in-use vehicle inspection program, owners will maintain their vehicles regularly so that eventually the air quality is enhanced through less emissions from vehicles

dsk_lp0992/korea

Annual Report 1991

TABLE 1 MOTOR VEHICLE POPULATION 1982 - 1991

ITEM	1982	1983	1984	1985	1986	1987	1988	1989	1990	1991
1 CARS										
1 Private cars & station wagons	160,757	162,120	195,973	200,032	200,163	201,651	216,928	234,436	247,606	261,050
2 Company cars & station wagons	16,044	16,962	16,248	18,106	17,566	17,868	18,859	20,010	20,361	19,678
3 Traction cars & station wagons	920	1,090	1,065	1,104	910	656	957	654	663	904
M Private hire cars & station wagons	4,515	4,168	4,159	4,030	3,314	3,081	3,140	3,135	3,243	3,665
Sub-total	182,236	233,370	219,555	233,271	221,945	223,256	239,694	259,937	272,675	285,238
2 MOTORCYCLES										
1 Motorcycles and scooters	135,359	140,267	133,482	126,337	119,241	115,476	116,476	119,897	121,336	121,164
Sub-total	135,359	140,267	133,482	126,337	119,241	115,476	116,476	119,897	121,336	121,164
3 BUSES										
1 Omnibuses	3,219	3,287	3,354	3,597	3,530	3,482	3,410	3,304	3,220	3,145
2 School buses	2,736	2,733	2,645	2,573	2,427	2,345	2,207	2,047	2,011	1,959
3 Private hire buses	648	666	1,062	1,232	1,271	1,354	1,478	1,615	1,766	1,916
M Private hire buses	507	616	687	778	862	944	1,039	1,174	1,208	1,234
V Excursion buses	327	338	336	356	383	459	697	865	1,063	1,068
Sub-total	7,437	7,640	8,184	8,917	8,473	8,633	8,789	8,665	8,739	9,342
4 TAXIS										
1 Public taxis	10,276	10,068	11,058	10,836	10,677	10,552	10,473	10,692	12,239	12,705
2 School taxis	5	5	4	3	0	0	0	0	0	0
Sub-total	10,281	10,073	11,062	10,839	10,677	10,552	10,473	10,692	12,239	12,705
5 GOODS AND OTHER VEHICLES										
1 Goods - van - passenger vehicles	555	6,757	6,959	6,781	6,634	6,562	6,525	6,466	6,344	6,202
2 Light Goods Vehicles	63,831	59,208	59,940	57,915	55,442	64,211	53,833	53,825	53,065	52,272
3 Heavy Goods Vehicles	29,173	33,188	35,436	39,208	38,241	39,756	43,183	48,481	52,941	56,573
M Others	3,744	4,061	4,042	3,711	3,446	3,519	2,940	2,969	3,294	3,756
Sub-total	97,003	105,214	111,577	107,615	105,363	109,654	109,681	119,724	127,644	139,803
6 EXEMPTED VEHICLES										
1 Cars and station wagons	1,914	1,690	1,913	2,036	1,935	2,112	1,957	1,969	2,042	2,113
2 Motorcycles and scooters	1,540	1,302	1,201	1,227	1,146	1,068	1,094	1,099	1,187	1,246
3 Buses	164	164	179	180	185	180	196	131	150	156
M Goods Vehicles	1,373	1,370	1,296	1,182	1,112	1,114	1,202	1,156	1,186	1,163
V Others	2,967	3,168	3,333	3,372	3,203	3,565	4,117	4,328	4,783	5,335
Sub-total	7,958	7,614	7,922	7,861	7,581	8,091	8,659	9,663	10,693	11,813
ALL MOTOR VEHICLES (TOTAL)	440,276	476,208	491,322	486,760	473,659	471,124	491,698	530,537	542,352	559,304

TABLE 2 MOTOR VEHICLE ANNUAL GROWTH RATE 1982 - 1991

TYPE OF VEHICLES	1982	1983	1984	1985	1986	1987	1988	1989	1990	1991
CARS	11.6%	12.1%	7.3%	1.6%	-0.6%	0.7%	6.9%	6.2%	5.4%	4.7%
MOTORCYCLES	7.1%	3.6%	-4.8%	-5.4%	-5.6%	-3.2%	0.9%	2.9%	1.2%	-0.1%
BUSES	9.3%	5.4%	3.4%	5.3%	-0.7%	1.3%	2.4%	2.4%	3.4%	0.5%
TAXIS	4.2%	3.6%	3.6%	-1.1%	-2.4%	-1.2%	-0.7%	1.7%	14.9%	3.6%
GOODS AND OTHER VEHICLES	10.4%	6.5%	5.6%	-1.5%	-3.6%	-0.7%	3.4%	4.6%	3.4%	2.7%
EXEMPTED VEHICLES	5.2%	-0.6%	0.1%	0.6%	-5.1%	5.9%	6.2%	2.1%	7.6%	6.6%
ALL MOTOR VEHICLES (TOTAL)	9.6%	8.2%	3.2%	-0.9%	-2.7%	-0.5%	4.4%	5.8%	4.2%	3.1%

121

TABLE 3 MOTOR VEHICLES BY TYPE OF FUEL USED 1982 - 1991

YEAR	CARS		BUSES		GOODS & OTHER VEHICLES	
	Petrol	Diesel	Petrol	Diesel	Petrol	Diesel
1982	182,230	6	492	6,945	63,000	33,943
1983	204,365	5	671	7,169	67,260	37,964
1984	219,362	3	619	7,265	70,117	41,290
1985	223,269	2	948	7,569	68,552	41,153
1986	221,943	2	996	7,477	66,222	39,540
1987	223,454	2	1,060	7,523	65,447	39,601
1988	238,990	4	1,159	7,629	66,346	42,236
1989	256,535	2	1,252	7,743	67,549	46,224
1990	272,474	1	1,350	7,948	67,872	49,772
1991	265,294	4	1,396	7,944	67,952	52,850

Note: Exclude motorcycles, taxis and exempted vehicles.

SCHEDULE OF COMPULSORY MOTOR VEHICLE INSPECTION

<u>Type of Vehicle</u>	<u>Frequency</u>		
	Below 3 years	3 to 10 years	10 yrs & above
All motorcycles and scooters	Nil	Annually	Annually
All cars and station-wagons	Nil	Biennially	Annually
All tuition cars	Annually	Annually	Annually
All private hire cars	Annually	Annually	NA
All public service vehicles			
Taxis	6-monthly	6-monthly	NA
SBS buses	6-monthly	6-monthly	6-monthly
TIB buses	6-monthly	6-monthly	6-monthly
CSS buses	6-monthly	6-monthly	6-monthly
Other buses	Annually	Annually	6-monthly
All light goods vehicles (MLW 3000 kg and below)	Annually	Annually	6-monthly
All heavy goods vehicles (MLW 3001 kg & above)	Annually	Annually	6-monthly
All other heavy vehicles	Annually	Annually	6-monthly

dsk17/inspctrs

PROCEDURE FOR DIESEL VEHICLE EXHAUST SMOKE TEST

(A) BEFORE COMMENCEMENT OF TEST

- (1) The smokemeter should be switched on for at least 2 minutes before any test is carried out.
- (2) The accelerator must be depressed a few times to clear the exhaust system.
- (3) The manometer must be zero-checked before switching on.

(B) TESTING

- (4) Insert the probe into the exhaust pipe.
- (5) Zero check the smokemeter.
- (6) Close "gate valve" and open by-pass valve fully. Depress accelerator to full extent, and open gate valve until the manometer pressure is 50 mm. Release accelerator and close by-pass valve.
- (7) Open by-pass valve fully, and depress accelerator uniformly (not too slow nor too quickly) to full extent until the engine attains its full governed speed and release accelerator. Read off the highest SD reading on the microammeter.
- (8) The above test is to be repeated the required number of times in quick succession within 5 seconds to obtain at least 2 consistent readings (ie. reading within 3 HSU of each other).

(C) AFTER TESTING

Check that the meter still reads zero at the end of the test.

(Please ensure (1) & (2) is carried out)

disk 24/smkprcde

PETROL VEHICLE EMISSION TEST PROCEDURE (Crypton Model 270)

- 1 Switch on the analyser and allow it to warm-up (about 10 minutes) before conducting any test.
- 2 Operate the black rocker switch to start the gas pump. The pump may be switched on at other times if required but the switch should normally be left in the OFF position when not required to maximise the life of the pump assembly.
- 3 Check the condition of the gas flow indicators. If the red lamps are ON, filter need servicing. The green lamps indicate that the system is clear for test.
- 4 Warm up the engine to normal operating temperature and ensure that all components essential to performance, i.e. spark plugs, contact points, etc. are in good condition.
- 5 Connect the gas sampler pipe to the inlet pipe on the rear panel of the analyser and insert the probe into the vehicle exhaust tailpipe.
- 6 Start the engine and check that the engine is at the correct idling speed.
- 7 Check the readings.

dsk25/petroleum

**Expert Group Meeting on in - use vehicle inspection for
Emission Control in the Asia - Pacific Region. South Korea**

20 - 22 October 1992

**Presentation by
D.D.J. Wijesundara
Commissioner of Motor Traffic
Sri Lanka.**

The Government of Sri Lanka has embarked on a programme of industrialisation, which would result in urbanisation. Due to this change there has been a rapid growth of almost a four-fold increase in the vehicle population during the last 12 years. The present vehicle population is over 950,000. The Motor Traffic Act is the guiding legislation for the registration, construction, prohibition, cancellation, etc. of motor vehicles and framing of regulations with regard to vehicle emission control. The implementing authority is the Department of Motor Traffic which comes under the Ministry of Transport and Highways. The vehicles in use in Sri Lanka are gasoline and diesel operated vehicles.

The Ministry of Transport & Highways and the Department of Motor Traffic in conjunction with the Ministry of Policy Planning and Implementation have launched on a Metropolitan Environmental Improvement Programme. A country workshop on Air Quality Management was conducted for one day in August 1991 in association with the Central Environmental Authority. The workshop covered areas of : vehicular emission, pollution control, testing, monitoring, and enforcement measures. Prior to the above programme, the technical, legal, policy and institutional aspects of Air Quality Management were discussed. A short course on Air Quality Management was conducted by the Metropolitan Environment Improvement Programme (MEIP) which was implemented by the Ministry of Environment and Parliamentary Affairs and approved by the World Bank, United Nations Development Programme, United States Agency for International Development (NAREPP - IRG) the Japanese International Cooperation Agency coordinated by the staff of the Ministry of Policy Planning & Implementation from 6th to 10th July 1992.

The Metropolitan Environment Improvement Programme, UNDP and World Bank funded initiative is being executed in five Asian Metropolitan cities : Beijing, Bombay, Colombo, Jakarta, and Manila.

Sri Lanka did not have regulations to control vehicle emissions. But a recent Gazette Notification has given new regulations with regard to the change of petrol engines ^{to diesel} engines (Annexure I). The Government has enforced a special registration fee of Rs. 35,000/- (approx. US \$ 580) for motor cars and dual purpose vehicles converted

(2)

from petrol to diesel. This is to discourage people from converting petrol cars to diesel, as most of the engines are discarded and over 3 years old.

The Ministry of Transport & Highways spearheaded a campaign to eliminate excessive vehicle emission and remove pollution caused by defective vehicles on roads during the first fortnight of June 1992. This vehicle emission control campaign (VECC) was carried out by the Ministry of Environment and Parliamentary Affairs with the assistance of State sponsored organisations such as the Department of Police. It was intended to educate motorists as well as the general public through the media and other agencies.

Environmental dangers caused by motor vehicle emission have adverse effects on public health. Carbon monoxide, lead, particulate nitrogen oxide, toxic hydro carbon are some of the elements which cause a variety of adverse effects. The Department of Motor Traffic and the Central Environmental Authority took up the initiative to obtain unleaded petrol through the Ceylon Petroleum Corporation. Catalytic converters are available in most of the new used gasoline operated cars imported from Japan, but this is of no use as the petrol available in Sri Lanka is leaded. Uncontrolled diesel engines emit more particulate than gasoline engines. Diesel exhaust accounts for a major portion of the pollution of ambient air. More than 90 per cent of carbon monoxide emitted come from Motor Vehicles.

The organisational structure of the motor vehicle emission control in Sri Lanka is comprised of the following institutions:-

1. Ministry of Transport & Highways
2. Ministry of Environment & Parliamentary Affairs
3. Department of Motor Traffic
4. Department of Police

The Department of Motor Traffic is empowered under the Motor Traffic Act to prohibit unroadworthy motor vehicles.

A Cabinet Tender Board headed by the Secretary, Ministry of Environment and Parliamentary Affairs has been appointed to consider the purchase of 65 smoke meters for the purpose of inspecting diesel vehicles regarding emission. The other members of the Tender Board are representatives of the Ministry of Policy Planning & Implementation and the Department of Motor Traffic.

Contd.....03

(3)

The measuring standard proposed is the I.S.O. standard. The Department of Motor Traffic conducts road checks with the assistance of the Police regarding road worthiness of vehicles. The Government would take strict measures to curb the use of unroadworthy belching vehicles on all roads as the vehicle population will be double the present number over the next 10 to 15 years. The standard of motor cycles will have to be improved to eliminate pollution. For this purpose the two stroke motor cycles will have to be eliminated and the four stroke motor cycles encouraged as pollution is much less in the latter category. Necessary steps will be taken to control pollution from motor vehicles, as given below:-

1. Various steps could be taken to reduce vehicle emission in Sri Lanka by way of prohibition, cancellation of registration of high polluting vehicles. This could be easily done at the time vehicles are taken for mandatory inspection for issue of fitness certificates, which are issued by approved garages.
2. An awareness programme of vehicle emission control will be launched in cooperation with the Ministry of Environment and Parliamentary Affairs to educate vehicle owners, road users and school children.
3. The Constitution of the Socialist Democratic Republic of Sri Lanka, Article 28, states that it is the duty of every citizen of Sri Lanka to protect nature and conserve her riches. For the implementation of this task Sri Lanka has Statutes directly or indirectly important for Natural Resources Management and Environment Protection.
4. The fuel used in Sri Lanka is a contributory factor for air pollution. The Ceylon Petroleum Corporation, which imports crude oil purifies it in its refineries. Lanka Petrol is classified into 3 categories as :
2 star & 3 star, Lanka Auto Diesel and Lanka Super Diesel. Approximately 150,000 metric tons of 2-Star Petrol, 2,000 metric tons of 3-Star Petrol, 550,000 metric tons of Lanka Super Diesel are

Contd.....04.

(4)

produced by the Ceylon Petroleum Corporation, which are of good standard.

(Annexure)

5. Sri Lanka has no law to establish emission standards. It is necessary to make decisions about phasing of the various strategies. The early stages of the programme should be devoted for laying down firm foundations regarding performances. The preliminary steps would be the adoption of necessary and feasible standards. The Department of Motor Traffic has recommended the I.S.O. Standards to be adopted for vehicle emission. Imports of vehicles should also be limited. The present regulation that motor cars over 3 years old should not be imported is necessary to be ^{re-}considered. The Government is going ahead with the decision to stop import of second-hand diesel engines which are over 3 years old. Sri Lanka could profit by the adoption of current and appropriate policies and technologies which continue to develop in other countries. The experience of other countries could be usefully adopted in Sri Lanka. Many countries have shown that by reducing the lead content in gasoline and sulphur in diesel, the noxious emission in vehicles could be lowered considerably. The same problems which led to the adoption of tight standards in the highly industrialised countries have to be taken into consideration by developing countries like Sri Lanka.
6. Most countries are moving towards clearer options, such as, lead-free gasoline and lo-sulphur diesel in most of the industrialised world. Unleaded gasoline has been the norm in these countries for more than a decade. The substitute clearer burning alternative fuel as liquified petroleum gas could reduce belching. However, Sri Lanka is not producing this alternative fuel.

Contd.....05.

7. Root causes for vehicle emission have to be understood and addressed as a part of a long term strategy. Penalties have to be imposed for the control of high pollution. Overloading of vehicles, which causes pollution of air, has to be stopped. Suitable action has also to be taken against violators of the Emission Control Campaign.

LANKA PETROL

(2 star)

Code : 011, C24

SPECIFICATION

METHOD

Appearance	Clear and free from water and soluble impurities	-
S.G. 60/60 ^o F	To be reported	IP 160
Total Sulphur, % wt.	Max. 0.10	IP 243
<u>Distillation:</u>		ASTM 86/IP 123
IBP, °C	To be reported	
10 %, °C	45 - 70	
50 %, °C	80 - 125	
90 %, °C	Max. 180	
PBP, °C	Max. 205	
Res. % V	Max. 2	
R.V.P. @ 100 ^o F Lbs,	Max. 9	IP 69
Octane Number °F-1	Min. 90 - 92	ASTM - 908
Existent gum mg/100 ml.	Max. 2	ASTM 381/IP 131
TEL, ml/IG.	Max 3.0	IP 96
Cu-strip	Max. IB	ASTM 130/IP 154
Dr. Test	Neg. or less than 15 ppm. RSH	IP 30
Ind. period @ 212 ^o F	Min. 500 minutes	ASTM 525/IP 40

If a mogas blending component is transferred to Kolonnawa it should meet all specifications besides octane number.

Marketing Colour - White

Revised : 19/08/1982

kg./- /can

LANK AUTO DIESEL OIL

Cc : 013

	<u>Specification</u>	<u>Method</u>
Appearance.	Clear and free from water and visible impurities.	-
Colour	max. 3.5	ASTM D 1500/IP 196
S.G. 60/60°F	Max. 0.870	IP 160
Flash Point PH cc, °F	Min. 140	ASTM D 93/IP 34
Min. Viscosity cs at 100°F	1.6 - 6.0	ASTM D 445/IP 71
Cloud Point, °F	Max. 55	ASTM D 2500/IP 219
Carbon residue, Conradson carbon on 10% bottoms		
% wt.	Max. 0.2	ASTM D 189/IP 13
Ash, % wt	Max. 0.02	IP/4
Sulphur, % wt.	Max. 1.1	ASTM D 129/IP 61
Distillation :		ASTM D 86/IP 123
INP, °c	To be reported	
10%, °c	To be reported	
50%, °c	To be reported	
90%, °c	To be reported	
FBP, °c	Max. 400	
Rec. at 315°c % V.	Min. 50	
Rec. at 350°c % V.	Min. 80	
Diesel Index	Min. 45	IP 21
Cu - Strip	Max. IB	ASTM D 130/IP 154
Total Acid No. KOH mg/g	Max. 0.2)	
Strong Acid No. KOH mg/g	Nil)	IP 1
Calorific Value	Min. 10,556	IP 12
Gross, Kcal/kg.		
Marketing Colour:	Amber	

Revised: 19/08/1982

UP/bgs./cns

LANKA SUPER DIESEL OIL

Code : 016

	<u>SPECIFICATION</u>	<u>METHOD</u>
Appearance	Clear and free from water and visible impurities	
Colour	Max. 3.5	ASTMD 1500
S.g. 60/60°F	Max. 0.870	IP 160
Flash Point PM cc°F	Min. 140	ASTMD 93/IP 34
Viscosity Redwood - 1 @ 100°F, Sec.	30 - 43	ASTMD 445/IP 71
Cloud Point, °F	Max. 55	ASTMD 2500/IP 219
Carbon residue, Conradson Carbon on 10% bottom, % wt.	Max. 0.2	ASTMD 189/IP 13
Sulphur, % wt.	Max. 0.5	ASTMD 129/IP 61
Diesel Index	Min. 45	IP 21
Cu - strip	Max. IB	ASTMD 130/IP 154
Calorific Value Gross, Kcal/kg.	Min 10,556	IP 12

DISTILLATION:

IBP, °c	To be reported	
10%, °c	To be reported	
50%, °c	To be reported	
90%, °c	To be reported	
FBP, °c	Max. 400	
Rec @ 315° C%V	Min. 50	
Rec @ 350° C%V	Min. 80	
Ash, % wt.	Max. 0.02	IP 4
Acid No. Total KOH mg/g.	Max. 0.2	IP 1.
Strong Acid No. KOH mg/g.	Nil	
Marketing Colour	Amber	

Revised : 19.08.1982

.bgs/-/cns

REGISTRATIONS OF NEW MOTOR VEHICLES

1977 - 1992 , JANUARY , JUNE

YEAR	PETROL		DIESEL	NON-FUEL	KEROSENE	TOTAL
	MOTOR CYCLES	OTHER VEHICLES				
1977	1106	3280	3677	69696	67	8826
1978	5257	7941	9669	1306	41	24214
1979	15459	11917	12374	2463	181	42394
1980	34725	7374	17726	3851	100	63776
1981	17160	7024	12036	1135	36	37391
1982	10847	8554	9453	606	21	29481
1983	14431	9246	12722	769	8	37176
1984	16873	6437	14691	846	16	38863
1985	22782	7287	15184	647	1	45903
1986	26593	7533	12169	678	-	46974
1987	29041	7102	10065	676	-	46884
1988	27837	7525	9062	401	-	44825
1989	66696	7837	9574	338	-	84445
1990	84424	9426	12094	280	-	106224
1991	58643	5083	20344	376	-	84446
1992 Jan-June	33485	3042	13167	258	-	49952
Total	465359	116608	194007	15326	474	791774
		581967				
%	58.8	14.8	24.5	1.9	-	100.0

TOTAL VEHICLE POPULATION END OF 1976 - 199660

TOTAL VEHICLE POPULATION END OF JUNE 1992 - 954330

TOTAL NO. OF VEHICLES CANCELLED IN THIS PERIOD - 37139

Registration of new motor vehicles, 1977 to 1992 (Jan-June)
(By fuel type)

Year:	Cars	M/Cyc:	Buses	D/Purpose:	Lorries	L/Trac!	L/Trac!	L/V/Trac!	L/V/Trac!	Total	G/Total									
:	Petr:	Dies:	Petr:	Dies:	Petr:	Dies:	Petr:	Dies:	Petr:	Dies:	Non	Ker:	All	Types						
1977:2895:	379:	-:	1106:	44:	995:	-:	231:	824:	1:	16:	9:	211476:	67:	680:	4386:	3677:	69:	67:	6826	
1978:5925:	958:	-:	5257:	184:	689:	-:	1688:	1237:	22:	47:	143:	-1763:	41:	1259:	13198:	9669:	1336:	41:	24214	
1979:9059:	1711:	82:	15459:	1005:	1318:	-:	1836:	14628:	-:	40:	16:	-14717:	101:	2423:	27376:	112374:	2463:	181:	42394	
1980:4828:	1854:	48:	34725:	495:	2951:	-:	2033:	17378:	39:	156:	18:	215502:	50:	3695:	142099:	11726:	3851:	100:	63776	
1981:4377:	1383:	-:	17160:	252:	2102:	-:	2359:	15482:	1:	194:	36:	-13068:	36:	941:	24104:	112036:	1135:	36:	37391	
1982:4907:	760:	-:	10847:	112:	2976:	-:	3508:	2845:	2:	103:	27:	-12869:	21:	503:	19401:	9453:	606:	21:	29481	
1983:4789:	681:	-:	14431:	572:	3677:	-:	3858:	4271:	4:	58:	27:	-14069:	8:	711:	23672:	112722:	769:	8:	37176	
1984:4124:	991:	-:	16873:	132:	4119:	-:	2164:	15935:	-:	128:	17:	-13646:	16:	718:	23310:	114691:	846:	16:	38863	
1985:5723:	1255:	-:	22782:	46:	3602:	401:	720:	11081:	604:	1:	104:	9:	-13603:	3:	543:	30069:	115184:	647:	3:	45903
1986:6245:	1052:	-:	26593:	39:	1996:	1219:	2573:	1313241:	-:	96:	17:	-13207:	1:	582:	34126:	112169:	678:	1:	46974	
1987:6453:	1242:	-:	29041:	4:	1232:	617:	2617:	2212870:	-:	9:	6:	4412060:	-:	667:	36143:	10065:	676:	-:	46884	
1988:6974:	1057:	-:	27837:	-:	1108:	521:	2481:	1412445:	-:	30:	16:	-11971:	-:	371:	35362:	9062:	401:	-:	44825	
1989:7304:	1468:	-:	6696:	4:	700:	514:	2635:	1112427:	-:	19:	4:	1012334:	-:	319:	74535:	9574:	338:	-:	84445	
1990:8757:	1074:	-:	84424:	3:	1234:	637:	4588:	2912747:	-:	38:	-:	2112430:	-:	242:	93850:	112098:	280:	-:	106224	
1991:4745:	1875:	-:	58643:	2:	3446:	283:	18173:	4013107:	10:	43:	13:	6313670:	-:	333:	63726:	120344:	376:	-:	84446	
1992:2739:	1690:	-:	33485:	-:	1514:	75:	5390:	281835:	-:	24:	-:	13112607:	-:	234:	36527:	113167:	258:	-:	49952	
Tot:	10430:	130:	45550:	2894:	3679:	4267:	4927:	18942:	90:	1165:	358:	273:	5191:	344:	58195:	19400:	15326:	474:	79115	

**IN-USE MOTOR VEHICLE INSPECTION
FOR EMISSIONS CONTROL IN THAILAND**

by

Preecha Orprasirth

Deputy Director General

Land Transport Department

Suvidh Voravisuthikul

Director of Transport Engineering Division

Land Transport Department

ABSTRACT

Air pollution situation in Thailand is serious in Bangkok and major cities, from the high levels of particulate matter, carbonmonoxide and hydrocarbon. Lead level has been relatively constant despite the increasing use of gasoline, due to the government's reduction of lead in the fuel. This report shows the motor vehicle emissions problem in Thailand and the ways that government performs to solve the problems.

INTRODUCTION

The situation of air pollution in Thailand is considered critical in Bangkok and major cities. The recent surveyed conducted by JICA in 1987 revealed that the particulate matter in Bangkok consisted of about 40% black smoke from Diesel-engine vehicles, which was the largest contributor.

In addition, surveys conducted by ONEB's air quality monitoring stations located in Bangkok have particulate matter at an annual average of more than 100 micrograms per cubic metre, which is the ambient air quality standards of Thailand.

The cause of air pollution described is motor vehicles, and in Bangkok alone there are about 2.5 million of them on which about 1 million are two strokes engine motorcycles. With the traffic congestion problem, and the rapid annual increase of new motor vehicles including about 600,000 motorcycles from 5 manufacturers and 200,000 cars from 12 manufacturers per year. In addition, lack of proper inspection for emissions from these motor vehicles, poor maintenance and operation of the engines, make the air pollution condition in Bangkok become even worst.

MOTOR VEHICLE POPULATIONS

(As of Dec. 31, 1991)

TYPE OF MOTOR VEHICLE	BANGKOK METROPOLIS	OTHER PROVINCES	WHOLE KINGDOM
ALL TYPE	2,111,284	6,315,802	8,427,086
MOTORCYCLES	887,289	4,634,102	5,521,391
TRUCKS AND BUSES	102,366	359,751	462,117

REGULATIONS AND ORGANIZATIONS CONCERNED WITH MOTOR VEHICLE EMISSIONS

All motor vehicles, under the Land Transport Act, must be registered and inspected by the Land Transport Department (LTD) , Ministry of Transport and Communications (MOTC). Buses, trucks and commercial vehicles will have to undergo inspection including the black smoke and/or carbon monoxide.

For motor vehicles under Motor Vehicle Act, motor vehicles are not required to have inspection except for the one which has not renewed its registration for more than one year, taxi, public motor tricycle, business service car, chartered vans and for hire car.

In use motor vehicles on street are subjected to random spot checks, conducted by the police and Land Transport Department ; the violated vehicles in black smoke for Diesel-vehicles or carbonmonoxide for gasoline-vehicles face a fines of 500 BAHT and vehicles must be corrected before the fines are paid. For motorcycles, a fine of 100 BAHT is enforced. At the present, there are about ten random check points per day and more than 25,000 arrests have been made last year.

MEASURES TAKEN TO SLOVE AIR POLLUTION PROBLEMS

Since the air pollution from motor vehiles in Thailand is considered as a serious environmental problem, the Royal Thai Government

has set up policies for relevant organization concerning the solution to solve this problem. The important measures are :

1. Emission standard for new motor vehicle. The Technical Committee 697 (TC 697) was appointed to determine emission standard for new motor vehicle. Two standards for gasoline engine (leaded and unleaded gasoline) and two stroke cycle engine for motorcycle are finished. The standard for diesel engine (small and large engine) is expected to be finished within this year.

2. The requirement of inspection for private car and motorcycle. The Land Transport Department has studied and planned to have an inspection for private car such as passenger car, light truck, and motorcycle. These car must have an inspection before renew annual registration. The Land Transport Department will authorize the private sector to make an inspection of these cars. At the beginning, the car at the age of 10 or more will be inspected. If everything go well, the car at the age of 3, 5, 7, 9 will be inspected. For the car that is more than 10 years will be inspected every year.

3. Exhaust emission control device. The Royal Thai Government announced that the passenger car which has 1600 c.c. engine or more must equip a catalytic convertor beginning from January 1, 1993. For the passenger car less than 1600 c.c. must equip a catalytic converter beginning from September 1, 1993.

LIMIT FOR IN-USE PETROL/DIESEL MOTOR VEHICLES

The Land Transport Department has established the emission standard measuring instrument by referring to the announcement of ONEB and the Ministry of Science, Technology and Environment. The summary of measuring method is shown in the below table.

BLACK SMOKE AND CARBONMONOXIDE EMISSIONS STANDARD FORM MOTOR VEHICLES

POLLUTANTS	MEASURING SYSTEM	EMISSION STANDARD	SUMMARY OF MEASURING METHOD	REMARKS
Black smoke	- BOSCH	50 %	- No-load at rapid acceleration maximum rotating speed.	Maximum value of the two measurements
	- BOSCH	40 %	- On test bench, running with full-load at 60% of the maximum rotating speed	Average value of the two measurements
	or HARTRIDGE	52 %		
Carbon monoxide	- Non-dispersive infrared detection	6 %	Idling	Average value of the two measurements

CONCLUSION

It is not possible to solve the air pollution problem in the country without cooperation from the public. The year 1989 have been designated by the government to be the year for protection of the environment, The theme is on atmospheric pollution with some emphasis on global change. Public campaign has been launched on black smoke and carbonmonoxide from motor vehicles. Even as the economic growth in the country has been rising more than 10 percent in the past three years, with even greater growth rates of motor vehicles, transportation and industry in the cities and countryside, the air pollution in Thailand and Bangkok is not proportionally increased. The government is taking the right direction by facing the problem with may produce the actual decrease of pollution in the next few years. Some pollutants, however, will be more difficult to solve. Suspended particulate matter will still be a major problem until the traffic problem can be solved.

Details of the Appendix of the Announcement of Ministry of Commerce No.2

on the Quality Standard of Gasoline

Item	Max./Min.	Regular gasoline	Leaded:Premium		Unlead:Premium		Test Method
			1st. Kind	2nd. Kind	1st. Kind	2nd. Kind	
1. Octane Number							
1.1 Research Octane Number (RON)							ASTM D 2699
(1) Producer	Min.	87.0	95.0	95.0	95.0	95.0	
(2) Distributor	Min.	86.6	94.6	94.6	94.6	94.6	
1.2 Motor Octane Number (MON)							ASTM D 2700
From 1 Jan.1994							
(1) Producer	Min.	76.0	84.0	84.0	84.0	84.0	
(2) Distributor	Min.	75.6	83.6	83.6	83.6	83.6	
2. Lead Content , g/l							ASTM D 2700
							ASTM D 2700
2.1 Before 1 Jan. 1995	Max.	0.15	0.15	0.15	0.013	0.013	
2.2 From 1 Jan. 1995	Max.	0.013	0.15	0.15	0.013	0.013	
3. Sulphur Content, % wt	Max.	0.15	0.15	0.15	0.10	0.10	ASTM D 1266
4. Phosphorus Content , g/l	Max.	-	-	-	0.0013	0.0013	ASTM D 3231
5. copper Strip corrosion, number	Max.	1	1	1	1	1	ASTM D 130
6. Oxidation Stability, minutes	Min.	360	360	360	360	360	ASTM D 525
7. Existent Gum, g/100 ml	Max.	0.004	0.004	0.004	0.004	0.004	ASTM D 381
8. Distillation							ASTM D 86
8.1 Temperature c							
(1) Evaporated, 10% vol.	Max.	70	70	70	70	70	

Item	M x./Min.	Regular gasoline	Leaded:Premium		Unleaded:Premium		Test Method
			1st. Kind	2nd. Kind	1st. Kind	2nd. Kind	
(2) Evaporated, 50% vol.	Min.	70	70	70	70	70	
	and.						
	Max.	110	110	110	110	110	
(3) Evaporated , 90% vol	Max.	170	170	170	170	170	
(4) End Point	Max.	200	200	200	200	200	
8.2 Residue, % vol	Max.	2.0	2.0	2.0	2.0	2.0	
9. Vapor Pressure @ 37.8°C , kPa.							
9.1 Non-Oxygenate Blends	Max.	62	62	62	62	62	ASTM D 323
9.2 Oxygenate Blends	Max.	62	62	62	62	62	ASTM D 4953
10. Benzene, % vol	Max.	3.5	3.5	3.5	3.5	3.5	ASTM D 3606
11. Aromatic , % vol							
11.1 From 1 Jan. 1994	Max.	-	50	50	50	50	
11.2 From 1 Jan. 2000	Max.	-	35	35	35	35	
12. Colour							
12.1 Hue		Red	Light Yellow	Light Yellow	Green	Green	
12.2 Dye Content , mg/l	Min.	10.0	-	-	4.0	4.0	
12.3 Intansity	Min.	-	0.5	0.5	-	-	
	and						
	Max.	-	1.0	1.0	-	-	
13. Water , % wt							
13.1 Non-Oxygenate Blends	Max.	none	none	none	none	none	
13.2 Oxygenate Blends	Max.	0.7	0.7	0.7	0.7	0.7	ASTM E 203

Item	Max./Min.	Regular gasoline	Leaded:Premium		Unleaded:Premium		Test Method
			1st. Kind	2nd. Kind	1st. Kind	2nd. Kind	
14. Oxygenated Compounds , % vol	Min and Max.	- 10.0	- 10.0	5.5 10.0	- 10.0	5.5 10.0	ASTM E 4815
15. PFI/TVDC Additive							
15.1 Before 1 Jan. 1995	Min.	-	X	X	X	X	
15.2 From 1 Jan. 1995	Min.	X	X	X	X	X	
16. Appearance		Clear Liquid and No Suspended Particle					

Government Gazette : Vol.109 Section 119 Dated 17 September 1992

**Detail of the Appendix of the Announcement of Ministry of Commerce No.3
on the Quality Standard of Diesel**

Item	Max./Min	1st kind	2-3 kind	Test Method
1. Specific gravity at 15.6/15.6 °C	Min. and Max.	0.81 0.87	0.81 0.87	ASTM D 1298
2. Cetane Number or Calculated Cetane Index	Min. Min.	47 47	47 47	ASTM D 613 ASTM D 976
3. Viscosity at 40 °C , cSt	Min. and Max.	1.8 4.1	1.8 4.1	ASTM D 445
4. Pour Point , °C	Max.	10	10	ASTM D 97
5. Sulphur Content , % wt.				ASTM D 129 or Equivalent
5.1 Before 1 Sep. 1993	Max.	1.0	0.5	
5.2 From 1 Sep. 1993	Max.	-	0.5	
5.3 From 1 Jan. 1996	Max.	-	0.25	
5.4 From 1 Jan. 2000	Max.	-	0.05	
6. Copper Strip Corrosion, number	Max.	1	1	ASTM D 130
7. Carbon Residue , % wt.	Max.	0.05	0.05	ASTM D 189
8. Water and Sediment , % vol.	Max.	0.05	0.05	ASTM D 2709
9. Ash , % wt.	Max.	0.01	0.01	ASTM D 482
10. Flash Point , °C	Min.	52	52	ASTM D 93
11. Distillation (90% recovered , °C)	Max.	357	357	
12. Colour	Max.	4.0	4.0	ASTM D 1500
13. Detergent Additive	-	X	X	

The currently used oils for 2 stroke engines in Thailand must has the physical and chemical properties of Thai Industrial Standard 1040-1991 (TIS 1040-1991)

Item	Characteristics	Limit
1	Viscosity at 100 °C , cSt	5.6 to 16.3
2	Viscosity Index , not less than	95
3	Flashing Point , °C not less than	70
4	Pour Point , °C not exceed	-5
5	Sulphali Ash , % wt. not exceed	0.5
6	Metal*, % wt. not less than	X

Note : * only principle metal have to specified.

X Figured by the maker and report to TISI or consuær.

REGISTRATIONS OF NEW MOTOR VEHICLES

1977 - 1992 , JANUARY , JUNE

YEAR	PETROL		DIESEL	NON-FUEL	KEROSENE	TOTAL
	MOTOR CYCLES	OTHER VEHICLES				
1977	1106	3280	3677	69696	67	8826
1978	5257	7941	9669	1306	41	24214
1979	15459	11917	12374	2463	181	42394
1980	34725	7374	17726	3851	100	63776
1981	17160	7024	12036	1135	36	37391
1982	10847	8554	9453	606	21	29481
1983	14431	9246	12722	769	8	37176
1984	16873	6437	14691	846	16	38863
1985	22782	7287	15184	647	1	45903
1986	26593	7533	12169	678	-	46974
1987	29041	7102	10065	676	-	46884
1988	27837	7525	9062	401	-	44825
1989	66696	7837	9574	338	-	84445
1990	84424	9426	12094	280	-	106224
1991	58643	5083	20344	376	-	84446
1992 Jan-June	33485	3042	13167	258	-	49952
Total	465359	116608	194007	15326	474	791774
		581967				
%	58.8	14.8	24.5	1.9	-	100.0

TOTAL VEHICLE POPULATION END OF 1976 - 199660

TOTAL VEHICLE POPULATION END OF JUNE 1992 - 954330

TOTAL NO. OF VEHICLES CANCELLED IN THIS PERIOD - 37139

Registration of new motor vehicles, 1977 to 1992 (Jan-June)
(By fuel type)

Year	Cars	M/Cyc	Buses	D/Purpose	Lorries	L/Trac	L/Trail	Ambu/Hers	L.V/Trac	L.V/Trail	Total	G/Total										
Petr	Dies	Ker	Petr	Petr	Dies	Petr	Dies	Petr	Dies	Dies	Non	Petr	Dies	Dies	Ker	Non	Petr	Dies	Non	Ker	All Type	
1977	2895	379	-	1106	44	995	-	-	231	824	1	16	9	2	1476	67	680	4386	3677	696	67	812
1978	5925	958	-	5257	184	689	-	-	1688	3237	22	47	143	-	4763	41	1259	13198	9669	1306	41	2421
1979	9059	1711	82	15459	1005	1318	-	-	1836	4628	-	40	16	-	4717	101	2423	27376	12374	2463	181	4239
1980	4828	1854	48	34725	495	2951	-	-	2033	7378	39	156	18	2	5502	50	3695	42099	17726	3851	100	6377
1981	4377	1383	-	17160	252	2102	-	-	2359	5482	1	194	36	-	3068	36	941	24184	12036	1135	36	3739
1982	4907	760	-	10847	112	2976	-	-	3508	2846	2	103	27	-	2869	21	503	19401	9453	606	21	2918
1983	4789	681	-	14431	572	3697	-	-	3858	4271	4	58	27	-	4069	8	711	23672	12722	769	8	3717
1984	4124	991	-	16873	132	4119	-	-	2164	5935	-	128	17	-	3646	16	718	23310	14691	846	16	3880
1985	5723	1255	-	22782	46	3602	401	720	1108	6004	1	104	9	-	3603	3	543	30069	15184	647	3	4590
1986	6245	1052	-	26593	39	1996	1219	2673	13	3241	-	96	17	-	3207	1	582	34126	12169	678	1	4697
1987	6453	1242	-	29041	4	1232	617	2617	22	2870	-	9	6	44	2060	-	667	36143	10065	676	-	4681
1988	6974	1057	-	27837	-	1108	521	2481	14	2445	-	30	16	-	1971	-	371	35362	9062	401	-	4402
1989	7304	1468	-	66696	4	700	514	2635	11	2427	-	19	4	10	2334	-	319	74535	9574	338	-	8444
1990	8757	1074	-	84424	3	1234	637	4588	29	2747	-	38	-	21	2430	-	242	93850	12098	280	-	10622
1991	4745	1875	-	58643	2	3446	283	8173	40	3107	10	43	13	63	3670	-	333	63726	20344	376	-	8444
1992	2939	1690	-	33485	-	1514	75	5390	28	1835	-	24	-	131	2607	-	234	36527	13167	258	-	4995
tot:	20177	19430	130	465359	2894	33675	4267	29277	18982	59277	80	1105	358	273	51991	344	14221	581967	194007	15326	874	79177

COUNTRY REPORT OF MALAYSIA

**CONTROL AND REGULATORY MEASURES
CONCERNING MOTOR VEHICLE EMISSIONS**

by

MARZUKI MOKHATAR
Environmental Control Officer
Mobile Sources Section
Department of Environment Malaysia

and

YACOB ISMAIL
Assistant Director
Technical Division
Road Transport Department, Malaysia

SEOUL 20-22 OCTOBER 1992

CONTROL AND REGULATORY MEASURES CONCERNING
MOTOR VEHICLE EMISSIONS

Marzuki bin Mokhatar *

&

Yacob bin Ismail **

INTRODUCTION

1. Malaysia, as a developing country is now moving towards industrialisation by the year 2020. As a result, transportation has become more essential and important for daily activities especially in urban areas. At present, the growth rate of motor vehicles is 10 - 12 % a year.
2. In Malaysia, motor vehicles had been identified as the major contributor to air pollution problems, particularly in urban environment. Studies and prediction based on local conditions conducted by the Department of Environment (DOE), showed that more than 70 per cent of the emission load are due to motorised vehicles. (Figure 1 and Table 1)
3. The type of fuel used determines the type of air pollutants emitted by the motorised vehicles. Particulate matters (black smoke) and SO_x are the type of pollutants normally associated from diesel-

*

Environmental Control Officer
Mobile Sources Section
Department of Environment, Malaysia

**

Assistant Director
Technical Division
Road Transport Department, Malaysia

powered vehicles. Lead oxides, carbon monoxide (CO), hydrocarbons (HC) and nitrogen oxides (NOx), are the air pollutants emitted from gasoline-powered motor vehicles.

VEHICLE STATISTICS

4. As at 30th June 1992, there are about 6 million registered vehicles in Malaysia of which 91.5 % of the vehicles were petrol driven while the remaining 8.5 % are diesel powered vehicles. Most of the diesel powered vehicles are for commercial use such as lorries, taxis and buses. (Table 2)
5. Motorcycles represented about 5.5 % of the whole population, all petrol driven. Smaller motorcycles up to 150 c.c dominated the market although there are some bigger c.c, the volume is small.
6. As for private vehicles , Malaysian national car is a common sight on the road. It is petrol driven vehicle with engine capacity of 1.3 litre and 1.5 liter. Japanese models such as Toyota , Mazda , Honda etc are also popular.

REGULATORY CONTROLS

Present Motor Vehicle Legislations

Control of Emission from Diesel Vehicles

7. Motor Vehicle (Control of Smoke and Gas Emission) Rules, 1977 came into force in 1978 in order to control the emission of black smoke from diesel

in which 50 Hartridge Smoke Units (HSU) is a limit to be complied .At present Hartridge smokemeter is used to measure the smoke density.

8. Enforcement officers of the Department of Environment, the Road Transport Department and the Traffic Police are empowered to enforce the Rules. The Department of Environment together with the Police have conducted numerous enforcement campaigns throughout Malaysia. The campaign consisted of kerbside smoke test, whereby at strategic points along the road, diesel-powered vehicles visually found to be emitting dark smoke will be tested and summoned will be issued if the smoke density is found to exceed the stipulated standard. Table 3 summarise the enforcement activities undertaken by the Department of Environment. Figures 2 and 3 further analysed the percentage of compliance according to type of vehicle .

Control of Lead Concentration in Motor Gasoline

9. In order to limit the level of lead emission from petrol-driven vehicles, the Department of Environment has introduced and enforced the Environmental Quality (Control of Lead Concentration in Motor Gasoline) Regulations, 1985. Under these Regulations, all petroleum refiners and importers in Malaysia are required to reduce the lead content in petrol from the initial 0.84 grams/litre to 0.4 grams/litre by July 1985 and to further reduce it to 0.15 grams/litre by January 1, 1990. Gasoline (petrol) samples from all oil refineries or storage depots and selected petrol kiosks throughout the country were taken for analysis to ensure compliance to the stipulated limit.

10. In 1991, a total of 105 samples of both Premium and Regular grades of petrol were taken for analysis. 24 were taken from petrol refineries and storage depots, while the remaining 81 samples were from petrol kiosks, selected at random. All the samples complied with the new level of 0.15 grams/litre as required by the Regulations.

VEHICLE INSPECTION

11. As stated in Road Transport Rules of Malaysia, the Director General of Road Transport Department of Malaysia has the power to inspect all motor vehicles at any time before registration.
12. The purpose of the vehicle inspection carried out is to check the road safety and worthiness of the vehicle concerned and compliance to the Malaysian Road Transport Act and Regulations. Inspection carried out is for commercial vehicle only such as lorries, taxis and buses.
13. Basically there are 5 different types of Vehicle Inspection being carried out namely :
 - a) Initial Inspection
 - b) Routine Inspection
 - c) Vehicle Re - inspection
 - d) Special Inspection
 - e) Accident Inspection

a) Initial Inspection

This inspection is for new vehicles imported from overseas or new vehicles manufactured from local assembly plant in Malaysia. It includes inspection

of weight, measurement , physical body inspection and fitting such as lamps, number plate etc. Only then the vehicle is allowed for registration.

b) Routine Inspection

These are inspections carried out every 6 months after the initial inspection. Checks are carried out especially on certain parts such as engine, brake , ball and steering joints, axles and tyres. Smoke test is also carried out to determine emission level.

c) Vehicle Reinspection

Any vehicle that fails during the initial inspection has to rectify the failure before clearance is given.

d) Special Inspection

The inspection is for vehicles involved in certain modification of the body or upgrading the engine.

e) Accident Inspection

These inspection are for vehicles involved in accident in order to determine the extent of damage for valuation purposes.

Summarised checklist format during inspection are as in appendix.

FUEL QUALITY

14. At present there are 2 types of petrol available in Malaysia market, leaded and unleaded petrol. Lead content for leaded regular and leaded premium are the same (0.15 gram/litre) but with different Octane Number (RON) of 85 and 97 respectively and red in colour. For unleaded petrol the octane number is 97 with lead content of 0.013 gram/litre and yellow in colour.

For diesel, the minimum and average value for cetane number is 47 and 51 respectively with sulphur content of 0.5 % by volume.

FUTURE PLAN

15. In order to effectively control the emission from motor vehicles, several approaches and strategies preventive in nature have been formulated.

Introduction of New Regulations to Control Emission from Gasoline and Diesel Engines

16. A set of regulations concerning gasoline engine has been proposed. The draft regulations is based on United Nations Economic Commission for Europe , UN/ECE R 15-04. Another set of regulations have been proposed for diesel engine based on UN.ECE R 24 and R 49.

17. Both these proposed regulations cover new and in-use vehicles with particular emphasis on type approval system for new vehicles. For new motor vehicles, installation of catalytic converters will be made compulsory.
18. Several discussions have also been initiated with motorcycle assemblers and traders for the purpose of introducing a set of regulations to control emission from motorcycles.

Clean Fuel

19. Of late, the use of unleaded gasoline (ULG) has been aggressively promoted by the Government. The oil industries responded favourably to the call and almost all of them have introduced lead-free gasoline by the end of 1991. At present the retail sale of unleaded gasoline is 31% of the total sale of gasoline in Malaysia.
20. The use Compressed Natural Gas (CNG) or Natural Gas for Vehicles (NGV) has also been encouraged by the Government. By the end of this year, the first 200 petrol engine will be fitted with dual fuel converter as a pilot project by PETRONAS, the National Oil Company of Malaysia.

With the incentive price of NGV 50% of the petrol price and conversion cost US \$950 the owner can recover the initial conversion cost within one year.

CONCLUSION

21. The air pollution problems in Malaysia are mainly due to the rapid development of manufacturing activities and urbanization. Emission from motor vehicles is the major contributor to the deterioration of air quality especially in urban areas.

30. The need to control vehicular emission is serious and require urgent attention not only from the Government but also from the private sectors.

MOEA/REPORT/MY/1/13102

REFERENCES

1. Dr. Abu Bakar Jaafar , Mohd Izzuddin Ghani,
Enviromental Impact of Automotive Exhaust Emissions
And Regulations for control.
2. Environmental Quality Report, 1991.
3. Road Transport Rules.

Table 4.

Malaysia : Summary of Emission of Pollutant (Uncontrolled) to the Atmosphere
by Sources ('000 MT), 1987-1991

Sources Emission	Mobile	Stationary Sources				Open Burning Practice	
		Power Station	Industrial Fuel	Domestic	Industrial Processes	Municipal Disposa	Industrial Waste
Particulate							
1991	3.6	2.60	7.40	1.12	15.76	18.3	13.60
1990	5.0	2.57	9.64	1.126	15.58	4.6	9.20
1989	3.7	2.42	6.44	0.88	15.4	1.3	5.96
1988	3.3	2.44	8.9	0.001	23.7	3.0	1.21
1987	3.0	1.1	10.4	0.002	-	4.4	1.85
SO_x							
1991	4.4	32.00	33.78	3.21	0.05	1.1	0.72
1990	3.2	31.24	39.21	3.0	0.04	0.1	0.01
1989	3.0	30.31	31.79	2.64	0.03	0.1	0.0009
1988	2.7	182.1	53.3	0.06	9.5	0.2	0.086
1987	2.7	195.0	54.1	0.04	-	0.1	0.084
NO_x							
1991	47.2	38.40	26.00	1.7	1.23	3.4	0.72
1990	43.2	40.02	26.55	1.6	1.15	1.0	0.01
1989	29.4	38.47	21.37	1.23	1.1	0.5	0.004
1988	35.9	36.9	21.6	0.008	1.9	1.0	0.523
1987	35.6	41.9	25.9	0.011	-	1.0	0.442
CO							
1991	595.5	1.10	5.45	0.169	0.32	26.3	7.1
1990	551.4	3.28	7.35	0.166	0.31	8.2	4.2
1989	510.9	1.67	1.75	0.13	0.3	6.4	0.6
1988	475.9	0.3	1.8	0.004	1.2	4.7	17.0
1987	506.1	0.2	4.7	0.016	-	8.2	21.5
HC							
1991	30.3	2.7	5.48	0.18	0.15	20.4	9.60
1990	28.0	1.13	1.667	0.177	0.14	4.0	2.10
1989	25.94	0.29	1.59	0.12	0.2	3.2	0.03
1988	24.3	1.7	1.7	0.02	0.2	14.2	2.21
1987	23.7	1.9	3.0	0.02	-	16.9	0.45
TOTAL							
1991	681.0	76.8	78.11	6.378	17.51	19.5	31.94
1990	630.8	78.24	84.41	6.069	17.22	17.9	15.52
1989	572.7	73.26	62.94	5.0	17.0	11.5	6.59
1988	542.1	223.4	87.3	0.093	36.5	23.1	20.976
1987	571.1	240.1	98.1	0.089	-	30.6	26.24
Percentage							
1991	70.9	8.0	8.1	0.7	1.8	7.2	3.3
1990	74.20	9.2	9.9	0.8	2.0	2.1	1.8
1989	76.5	9.8	8.4	0.7	2.3	1.5	0.9
1988	58.1	23.9	9.4	0.001	3.9	2.5	2.2
1987	59.1	24.8	10.2	0.009	-	3.2	2.7
Percentage Compared 1987							
	+11.8	-16.8	-2.1	+0.8	+1.8	+4.0	+0.6

Table 2

**Registered Motor Vehicles In Malaysia
As At 30th June 1992.**

Type of Vehicle	Gasoline	Diesel	Total
	No. of Vehicles	No. of Vehicles	
Motorcycles	3,363,287		3,363,287
Passenger Cars	1,970,542	68,177	2,038,719
Buses	1,617	27,624	29,241
Taxis	16,997	22,371	39,368
Lorries/Truck	167,540	258,994	426,534
Other (excluded Trailer)	17,017	149,227	166,244
Total	5,537,000	526,393	6,063,393

Table 3

Malaysia: Enforcement of Motor Vehicles (Control of Smoke and Gas Emission) Rules 1977, 1989-1991

Subject	Year														
	1989					1990					1991				
Total Number of Diesel Vehicles Registered ¹	298,913					332,080					367,895				
Number of Enforcement Campaigns	448					439					465				
Total Number of Vehicles Stopped for Inspection	42,284					38,322					40,487				
Type of Vehicles	L	B	T	O	PC	L	B	T	O	PC	L	B	T	O	PC
Number of Summons Issued	2470	1726	1205	1165	519	2506	1900	1160	1175	458	4344	2085	1259	1350	406
Total Number of Summons Issued	7,085					7,199					9,444				
Type of Vehicles	L	B	T	O	PC	L	B	T	O	PC	L	B	T	O	PC
Percentage of Compliance	89	78	75	78	74	87	76	71	76	66	81	73	70	73	65
Overall Percentage of Compliance	83							81					77		

¹ Source: Road Transport Department, Malaysia.

Note:

Type of Vehicles

- L - Lorry
- B - Bus
- T - Taxi
- O - Others
- PC - Private Car

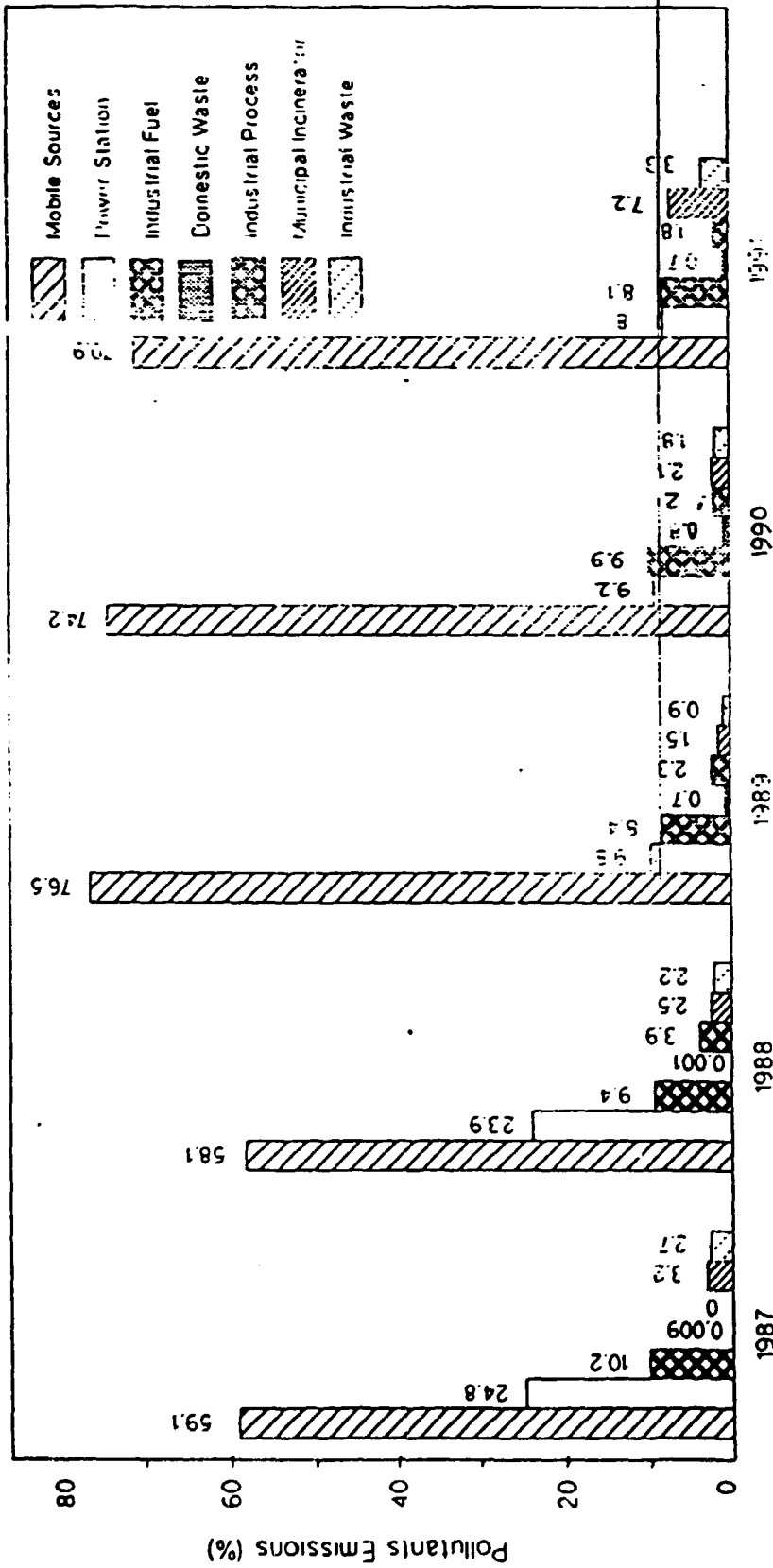

Figure 3.1, Malaysia: Trend of Emission of Pollutants to the Atmosphere by Sources, 1987-1991

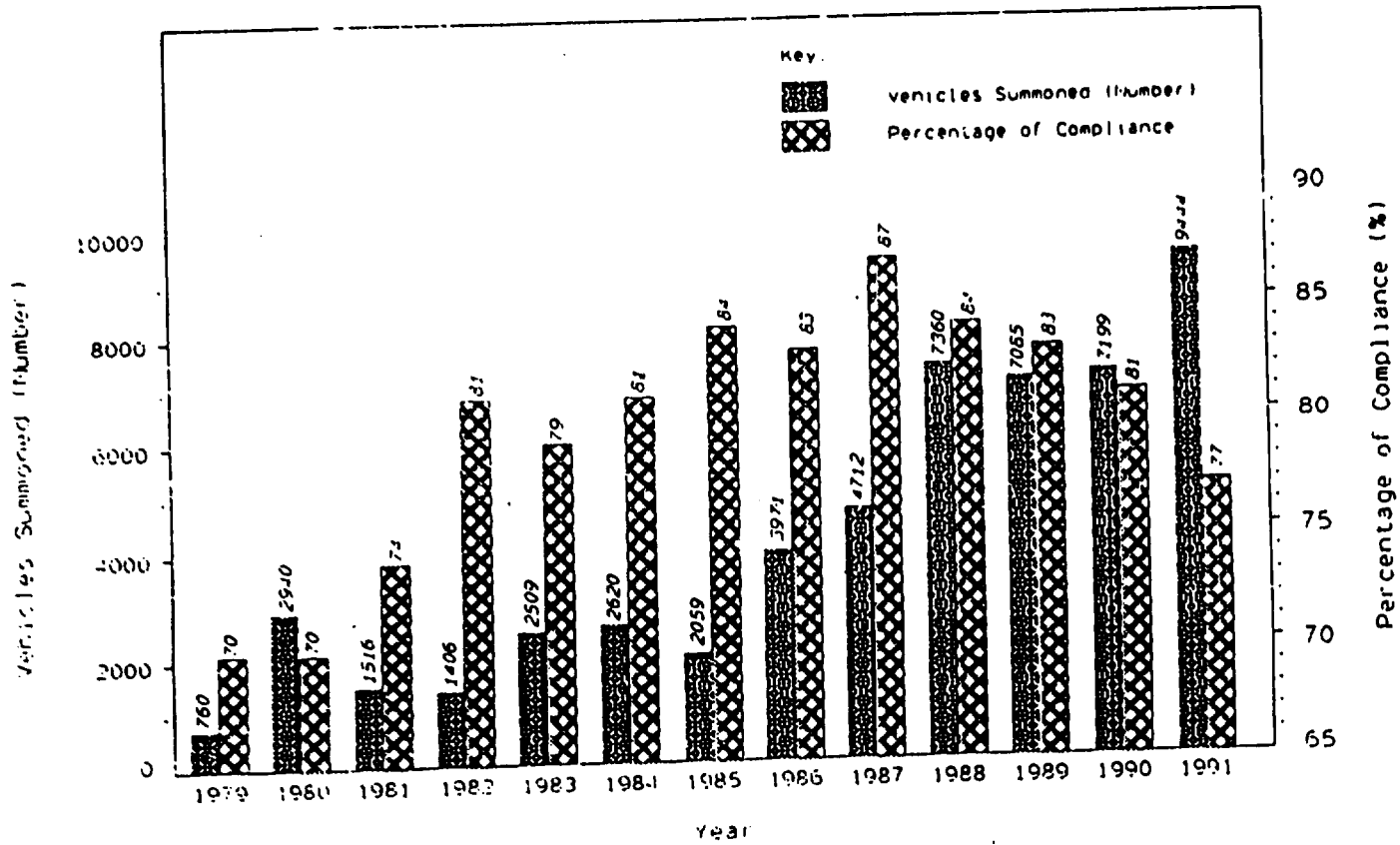

Figure 12: Malaysia: Enforcement of Motor Vehicles (Control of Smoke and Gas Emission) Rules 1977. Vehicles Summoned and Percentage of Compliance, 1979 - 1991.

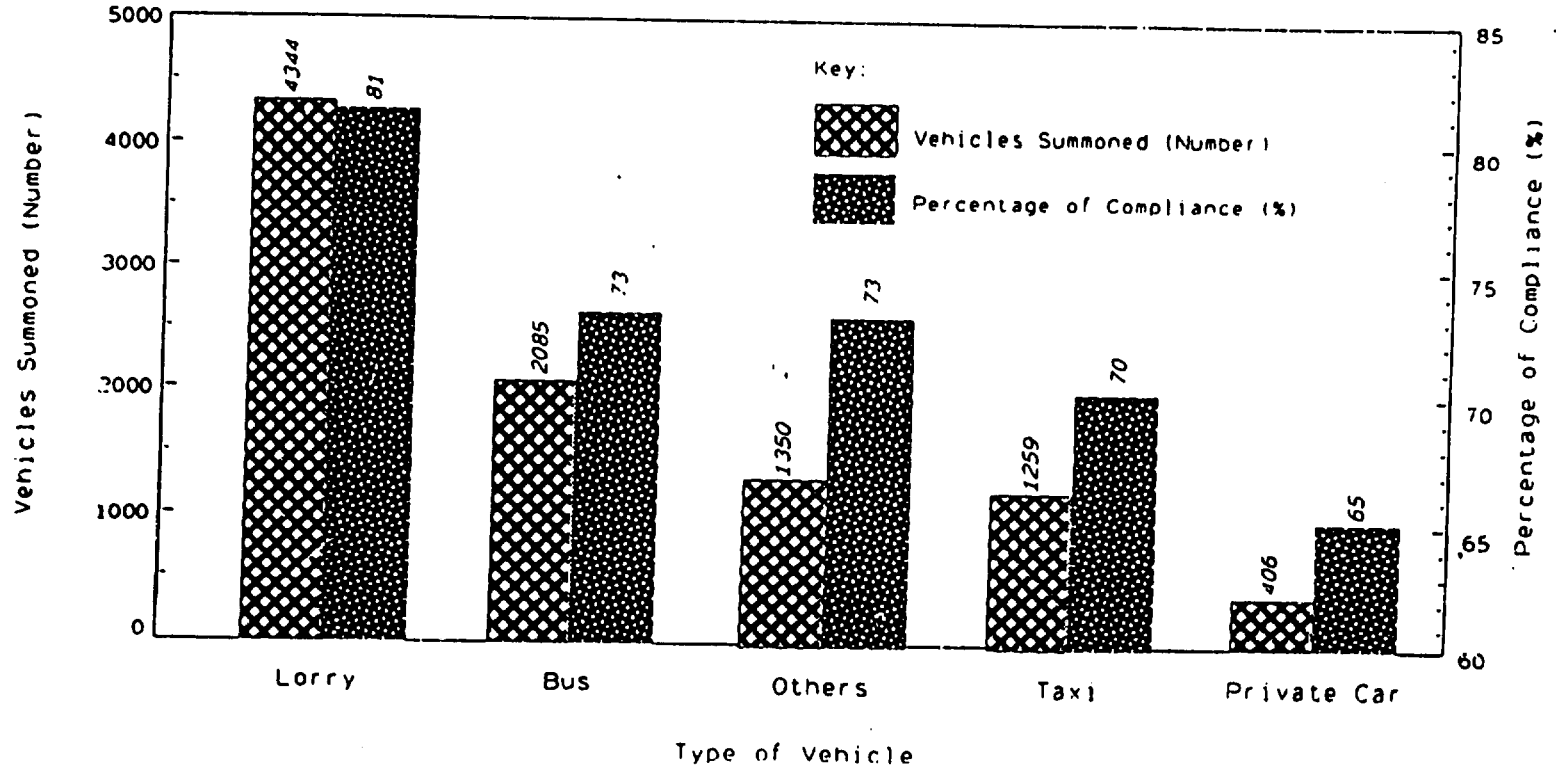

Figure 3. Malaysia: Enforcement of Motor Vehicles (Control of Smoke and Gas Emission) Rules 1977. Vehicles Summoned and Percentage of Compliance According to Type of Vehicle, 1991

INSPECTED ITEM DURING VEHICLE INSPECTION

STATIC INSPECTION

Engine & Chasis No.
F/Wheel Bearing, K/Pin & Bushes
Rad. Grill & Engine Bonnet
H/Lamps & Driec. Indicators Cond.
W/Screen glass, wiper & washes & R/Vision Mirrors
Dvr. Seats, Dvr Cab & Floorboard Condition
Crash Barrier & Link Chains
Coup. Gears, K/Pin, Sty Pin, Chains & L/Gear
Anti-Lighting Chain & Fire Shield
Tipping Equipt & Tipping Pivot Cond.
Semi Treler No. Plate
Ext. & Int. Body Marking & Paintwork
Base Marking, Roof Sign & Yellow Top
Entrence Door & Exit
Rear Bumper & Reg. No. Plate
Mudguards & Mudflaps Cond.
R/Lamps, D/India, Reflec & Pass Ligh Cond.
Body Panel, Wooden D/S & D/TB Cond.
Luggage Booth & Compartment
Passengers Seat Cond.
S/Window, Glass, Seals, Winders & Door Lock
S/First Aid, W/Instrument & Lighting
Floor-board & Closet Cond
Sty/Belt, Ref/Tri, F/Ext & Lift/Jack
Steering Joints & Connection
Steering Box & Mounting
Ft/Brake & H/Brake Linkages Cond.
Oil, Leaks, Engine Mounting & Cond.
Ft/Brake M/Pump. W/Cyls & Air Vacuum Tank
F/R/Spring Assy S/absobers & Axle
Main Chasis Frame & Subframe Cond.
Body Mounting & Connection
Prop. Shaft U/Joints & Connection.

SMOKE AND ROAD TEST

Smoke Emmision HSU
Elect. Wring, Wst. Sys & Audible Warning
Air/Vacum Warning, Build Up & Control
Mech. H/Brake Condition
Foot Brake Performance
Cluth Pedal & Operation
Transmission & Gear Level Shift
Engine Performance
Ste/alignment, Dve. Control & S/meter
Taximeter Operation & Condition.

**ENVIRONMENTAL QUALITY (CONTROL OF LEAD
CONCENTRATION IN MOTOR GASOLINE)
REGULATIONS, 1985***

In exercise of the powers conferred by section 51 of the Environmental Quality Act, 1974, the Minister after consultation with the Council, makes the following regulations:

1. Citation.

These Regulations may be cited as the Environmental Quality (Control of Lead Concentration in Motor Gasoline) Regulations, 1985.

2. Interpretation.

In these Regulations, unless the context otherwise requires—

“authorised officer” means such officer appointed under section 3 of the Act or any other officer to whom the Director General has delegated his power under section 49 of the Act.

3. Restriction on import or manufacture.

No person shall import or manufacture any motor gasoline which contains lead or lead compounds expressed as lead in excess of 0.40 gramme per litre on and after the date following the date of publication of these Regulations in the *Gazette*.

4. Restriction on possession, etc.

No person shall be in possession, offer or exhibit for sale, sell, deliver for use or exchange for use any motor gasoline which contains lead or lead compounds expressed as lead in excess of 0.40 gramme per litre on and after the 1st January 1986.

5. Restriction on import, etc.

Notwithstanding the provisions in regulations 3 and 4, no person shall import, manufacture, possess, offer or exhibit for sale, sell, deliver for use or exchange for use any motor gasoline which contains lead or lead compounds expressed as lead in excess of 0.15 gramme per litre on and after the 1st January 1990.

6. Manufacture for export.

Regulations 3, 4 and 5 shall not apply if the motor gasoline is manufactured for export outside Malaysia provided prior notice on the date of manufacture, quantity, place of storage, name of customers and anticipated date of export have been communicated to the Director General.

* Published as P.U. (A) 296/1985. Came into force on 1.8.1986.

7. Waiver of notification.

(1) For the purpose of effecting exemption under regulation 6 the Director General may establish a recording procedure to be followed by the manufacturer.

(2) Where an application has been made to the Director General by the manufacturer to adopt such procedure the requirement to give prior notice as prescribed under regulation 6 may be waived.

8. Authorised officer to produce identification and issue receipt.

Every authorised officer shall produce his identification before the collection of samples of motor gasoline and shall issue receipt for such quantity of sample collected.

9. Collection, sampling and analysing procedures.

For the purpose of determining the lead contents prescribed in these Regulations, the motor gasoline shall be collected, sampled and analysed in accordance with the procedures specified in the First Schedule.

10. Obstruction of authorised officer.

No person shall obstruct or delay any authorised officer in the collection and sampling of motor gasoline under regulation 8.

11. Licence required to contravene conditions.

No person shall, unless licensed, contravene the conditions specified in regulations 3, 4 and 5.

12. Granting of licence.

(1) Where the Director General is satisfied that—

(a) (i) the motor gasoline with higher lead concentration is needed for the investigation or research relevant to pollution problems; or

(ii) the motor gasoline with higher lead concentration is required for the operation of certain vehicles for rallies or racing purposes; or

(iii) the motor gasoline with higher lead concentration is required for specific uses which in the opinion of the Director General are not contrary to the intent and spirit of these Regulations; and

(b) that the use of such motor gasoline is confined to a small segment of the environment; and for such period that the accumulated level of lead is not likely to cause adverse effect on the environment,

he may grant a licence to contravene the conditions in regulation 3, 4 or 5.

(2) Application for such licence shall be made in such forms as may be prescribed by the Director-General.

13. Compounding of offences.

Offences against regulations 3, 4, 5 and 10 shall be offences which may be compounded by the Director-General, or any officer specifically authorised by the Director-General.

14. Fees payable.

(1) Every application for a licence under regulation 12 shall be accompanied by the necessary fees specified in the Second Schedule provided that such fees shall not be required in respect of plant, facilities or vehicles wholly owned by the Government of Malaysia.

(2) Payment of fees shall be made by cash, money order, postal order bank draft payable to the Director General who shall issue a receipt upon realisation of the payment.

FIRST SCHEDULE

**COLLECTION, SAMPLING AND ANALYSING PROCEDURES
(Regulation 9)**

Parameters	Methods
Lead Concentration	Malaysian Standards MS 118 and MS 912 or ASTM D3341

ASTM – American Society for Testing and Materials, U.S.A.

SECOND SCHEDULE

**FEE PAYABLE TO OBTAIN LICENCE
(Regulation 14)**

1. Application under regulation 12 (1) (a) (i) and 12 (1) (a) (iii)–
\$300.00
2. Application under regulation 12 (1) (a) (ii)–
\$500.00

Dated the 27th June 1985.

DATUK AMAR STEPHEN K.T. YONG,
*Minister of Science, Technology and
Environment*

MOTOR VEHICLES (CONTROL OF SMOKE AND GAS EMISSION) RULES, 1977*

In exercise of the powers conferred by sections 57, 73 and 135 of the Road Traffic Ordinance 1958, the Minister makes the following rules:

1. Citation and commencement.

These rules may be cited as the Motor Vehicles (Control of Smoke and Gas Emission) Rules, 1977 and shall come into force on such date as the Minister may by notification in the *Gazette* appoint.

2. Interpretation.

In these Rules—

“authorised officer” means a road transport officer, police officer or any officer duly authorised in writing by the Director General of Environmental Quality;

“free acceleration test” means a test for smoke emission of a motor vehicle with the transmission disengaged (in neutral gear) when the engine thereof is tested on full throttle from its lowest to its highest engine speed;

“Ringelmann Smoke Chart” means a miniaturised version of the Standard Ringelmann Smoke Chart as shown in Schedule A to these Rules;

“smoke limit” means the highest acceptable smoke density or opacity for any volume of gas that a motor vehicle may at any time emit into the atmosphere at or near the point of smoke discharge;

“smoke meter” means—

- (a) the Hartridge Mk. 3 smoke meter which is constructed to receive a volume of exhaust gas of a motor vehicle within a pressure range of 40 mm-65 mm of water and a temperature range from 140 degrees Centigrade-210 degrees Centigrade and to measure the density or opacity of its smoke content from 0 to 100 Hartridge Smoke Units (H.S.U.);
- (b) a device constructed to receive a volume of exhaust gas from a motor vehicle within specified pressure and temperature ranges and to measure the complete range of density or opacity of its smoke content in Absolute Units of Light Absorption from clear to total darkness or in such other correlated light absorption units;
- (c) any other equivalent device which may from time to time be prescribed by the Minister as a smoke meter.

* Published as P.U. (A) 114/1977. Came into force on 15.3.1978.

3. Prohibition on emission of excessive smoke.

(1) No person shall use or cause to be used any motor vehicle which emits smoke of a density which exceeds 50 Hartridge Smoke Units or its equivalent.

(2) For the purpose of this rule, the smoke emission capability of a motor vehicle found on a free acceleration test conducted by an authorised officer and in accordance with Schedule B to these Rules shall be taken as an indication that the vehicle has discharged and will continue to discharge smoke of an equivalent density when in use on the road and test results shall be recorded as shown in Schedule C to these Rules.

(3) A Ringelmann Smoke Chart may be employed in conjunction with the Hartridge/Ringelmann Correlation Chart as shown in Schedule D to these Rules to check density of smoke emissions for the purpose of detention of a motor vehicle for inspection and test on a smoke meter.

(4) A motor vehicle may be detained for inspection and test if it is only seen to discharge smoke of a darkness which is apparent to an authorised officer that the smoke limit therefore has been exceeded.

(5) In this rule "motor vehicle" means a motor vehicle fitted with a compression ignition engine.

4. Crankcase ventilation.

Every motor vehicle powered by a four-stroke petrol engine (other than a motor cycle) first registered for use on or after the coming into force of these Rules shall be so constructed or equipped with such device as to prevent the escape of gas from the crankcase of such motor vehicle into the atmosphere.

5. Exemption.

The Director General for Road Transport may, with the prior agreement in writing from the Director General of Environmental Quality, exempt any person or class or type of vehicle from the full compliance of any or all of these Rules.

6. Penalty.

Every person who fails to comply with the requirement of any of these Rules is guilty of an offence and is liable to a fine not exceeding five hundred ringgit or to a term of imprisonment not exceeding two weeks for a first offence and to a fine not exceeding one thousand ringgit or to a term of imprisonment not exceeding one month for a subsequent offence.

**SCHEDULE A
(Rule 2)
RINGELMANN SMOKE CHART**

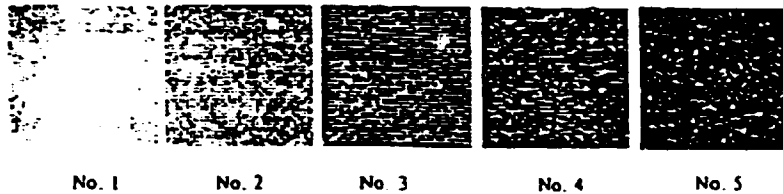

This chart is a direct facsimile reduction of the Standard Ringelmann Chart as issued by the United States, Bureau of Mines, in Information Circular 8333 of May 1967.

INSTRUCTION FOR USE

1. Hold chart at arm's length to view smoke at source.
2. Source of light or sun should be behind the observer.
3. Match smoke as closely as possible to corresponding shade on chart.

**SCHEDULE B
(Rule 3 (2))**

**PRESCRIBED TEST FOR SMOKE EMISSION OF A MOTOR VEHICLE
FITTED WITH A COMPRESSION IGNITION ENGINE**

1. The test shall be carried out with a smoke meter.
2. The smoke meter including its accessories shall be regularly serviced and maintained in accordance with the manufacturer's instructions. It shall have undergone tests and calibration not more than 12 months before the date of its use, by a competent authority appointed by the Director General for Road Transport, and be issued with a certificate of fitness recording the date on which as a result of those tests and calibration, the smoke meter was found to be in good working order.
3. Smoke test results provided by a smoke meter complying with the requirements of paragraph (2) shall be deemed to be accurate.
4. Test results shall be recorded on a Test Certificate as in Schedule C.

**SCHEDULE C
(Rule 3 (2))**

MOTOR VEHICLE SMOKE EMISSION TEST CERTIFICATE

Serial No.....

Registration No. of Motor Vehicle.....

Time.....Date.....

Make of Vehicle..... Testing Station.....

Class..... at.....

Type.....

Make Model and serial number of Smoke Meter used for test.....

Date last calibrated.....

Type of Test: *Free Acceleration.*

RECORD OF SMOKE EMISSION TEST

Test No. 1..... Smoke Units =

Test No. 2..... Smoke Units -

RESULTS:

Average Test No. () and Test No. ().....Smoke Units

I certified that the above-mentioned motor vehicle has been tested for smoke emission capability and found to emit a smoke density of.....Smoke Units which does not exceed/*exceeds the smoke limit of.....Smoke Units permitted under paragraph (1) of rule 3 of the Motor Vehicle (Control of Smoke and Gas Emission) Rules, 1977.

Issued and Signed by.....

Name (Block letters)

and

Designation of Testing Officer.....

TEST CERTIFICATE ISSUED TO

Owner/*driver of motor vehicle (name).....

of (Address).....

Time..... a.m./* p.m. Date..... Place.....

To whom issued: Owner/*driver (signature).....

Driving Licence No..... Expiring.....

** Delete where applicable.*

SCHEDULE D
(Rule 3 (3))

HARTRIDGE/RINGELMANN CORRELATION CHART

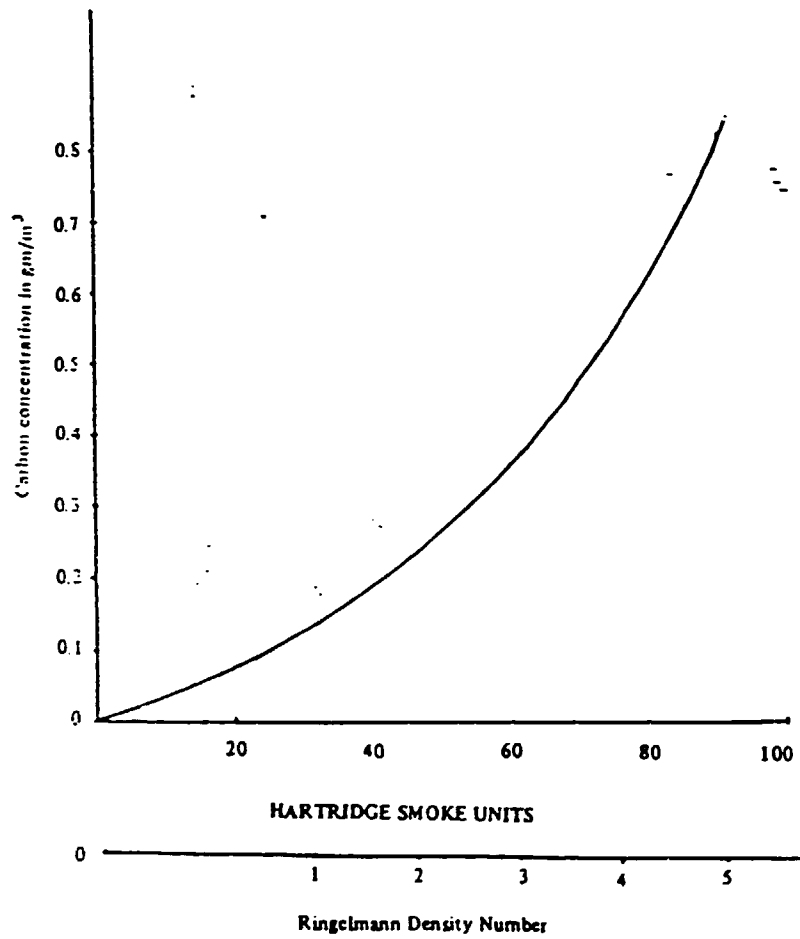

Made this 14th day of December 1977.

DATUK HAJI ABDUL GHANI GILONG,
Minister of Works and Utilities

**STATUS OF IN-USE
MOTOR VEHICLE INSPECTION
FOR EMISSION CONTROL
IN THE PHILIPPINES**

Prepared by:

*Mrs. Cirila S. Botor
Atty. Percival Cendana
Mr. Emmanuel Gutierrez*

STATUS OF IN-USE MOTOR VEHICLE INSPECTION FOR EMISSION CONTROL IN THE PHILIPPINES

Environmental and air pollution control legislation in the Philippines dates back to the 1960s, with several enactments and decrees occurring since that time.

The earlier rules merely addressed particulate emissions for motor vehicles while the more recent issuances also address gaseous emissions from gasoline-powered vehicles. Early legislations lumped vehicular emission control with regulation of horns and mufflers and empowered the then Land Transportation Commission (LTC) as the enforcement agency. Later the Philippine Environment Code (PDC 1152) gave the LTC responsibility for Motor Vehicle Emission regulation and to deputize other agencies as needed. The National Pollution Control Commission (NPCC) was designated as the standard setting agency with the LTC as the enforcement arm. Presidential Decree 1181 (PD 1181) later modified the Environmental Code to give the NPCC enforcement power over motor vehicle emissions with the LTC and the other agencies rendering supportive roles.

Executive Order 192 in 1987 subsequently eliminated the NPCC and passed the powers functions of that agency to the Department of Environment and Natural Resources. The DENR/National Capital Region then became responsible for enforcing PD 1181 motor vehicle emission control in Metro Manila.

Present enforcement activities focus on control of particulate emissions (black smoke) from existing diesel-fueled vehicles using the Metro Manila Road System.

The DENR/NCR has teams in the field each day on key Metro Manila routes to identify and stop suspected excessive smoke emitters. The team members visually test the vehicles and failed vehicles receive "citations" and the license plates thereof are confiscated until a certificate of DENR clearance is issued to the said vehicles.

Pursuant to Republic Act No. 4136, an administrative order numbered AO-91-005 was issued in 1991 by the Land Transportation Office establishing the New Motor Vehicle Inspection System. The motor vehicles covered are:

- a) All for hire motor vehicles except tricycles
- b) All for hire provincial buses where authorized routes include Metro Manila
- c) All private trucks, buses and mini-buses
- d) All motor vehicles found to have been operated without properly registered or with delinquent registration except tricycles and motorcycles.

Inspection of motor vehicles under the NMVIS cover the following:

- a) Identity and Construction
- b) Engine and Power Train System

- c) Frame and body
- d) Lamp/Light
- e) Brake System
- f) Steering System
- g) Buffer System
- h) Running System
- i) Safety devices
- j) Fuel System
- k) Exhaust Emission Control System
- l) Electrical System

The inspection with regard to emissions and general safety are combined. This is conducted in 5 stages as:

Stage 1 The vehicle is identified and various information is fed into the computer. The first inspection is done to check the vehicle's body condition, safety devices, lights and light signal system and other exterior body parts.

An HC-CO Exhaust Gas Test is conducted on the vehicle. A probe is inserted into the exhaust pipe to check HC-CO emissions from the vehicle.

Stage 2 This consists of three tests namely:

The side-slip test which checks the front and rear wheel;

The brake tests; and

The speedometer test.

Stage 3 The third stage is the headlight test. The vehicle is made to stop at a specified position which automatically activates the headlight tester.

Stage 4 In this stage the vehicle is driven to the pit where the undercarriage checking is done. The inspection is conducted visually to check under chassis systems.

Stage 5 Finally, the results from all the previous tests are tabulated and the verdict is handed over to the vehicle owner in official computer forms. In case of failure re-inspection may be scheduled

Inspections are conducted by the North MVIS and South MVIS in the National Capital Region. There is one inspection station each in Region 3 and Region 4.

EXHAUST EMISSION TEST

A Non-dispersive Infrared Analyzer (NDIR) type test is employed to measure the volumetric concentration of CO and HC of the vehicle being inspected with the following standards:

For gasoline-fueled engines:

CO: up to 6%

HC: up to 1200 ppm for vehicles with 4-stroke engines;
up to 7800 ppm for vehicles with 2-stroke engines; and
3300 ppm for vehicles with rotary and specialized engines.

For diesel-fueled engines

Smoke-up to 50%

Readings for CO and HC are taken at idle speed by inserting the probe into the tail pipe to a depth of 20-25 cm.

Readings for smoke are taken with pressed pedal.

Vehicles which fail the test are not allowed to register unless the deficiency is corrected.

Since the North MVIS started operation on May 15, 1992 the percentage of failure of inspected vehicles is shown as follows:

	<i>Inspected</i>	<i>Failed</i>	<i>%</i>
<i>May 15-29, 1992</i>			
HC-CO	55	15	27
Diesel smoke	192	13	7
<i>June 1992</i>			
HC-CO	167	52	31
Diesel Smoke	484	16	3
<i>July 1992</i>			
HC-CO	389	32	8
Diesel Smoke	1165	15	1
<i>August 1992</i>			
HC-CO	253	23	9
Diesel Smoke	744	18	2
<i>September 1992</i>			
HC-CO	187	5	3
Diesel Smoke	694	39	6

TEST FEES

The NMVIS charges a fee of P 50.00 and P 75. 00 for the inspection of a light vehicle and bus unit, respectively. A reinspection fee in the same amount is collected once only if the vehicle which failed in the initial test is reinspected.

TWO-STROKE MOTORCYCLES

Motorcycles represent a large and growing portion of the Metro Manila vehicle population. Since these are equipped with two-stroke engines (which combine the fuel and lubricant in the combustion process) their contribution to the overall air pollution burden of the city is disproportionate to their numbers.

It has been estimated that these motorcycles emit up to three times as much hydrocarbons per kilometre driven than do much larger passenger cars. For particulate they emit almost twice as much as jeepneys per kilometre driven.

FUEL STANDARDS IN THE PHILIPPINES

The Bureau of Product Standards has formulated the following Philippine National Standards for fuels:

- PNS 19:1990 - Specification for Motor Gasoline
- PNS 20:1992 - Specification for Diesel Oils
- PNS 21:1992 - Specification for Fuel Oils
- PNS 22:1994 - Specification for Liquefied Petroleum Gas
- PNS 235 - Specification for Two-Stroke Cycle Gasoline Engine Oil

The existing levels of lead in gasoline are as follows:

	<u>Regular</u>	<u>Premium</u>
up to 1993	0.40 g/L	0.60 g/L

It has been proposed that for the coming years lead levels shall be as follows:

	<u>Regular(g/L)</u>	<u>Premium(g/L)</u>
1994-1995	0.20	0.40
1996 onward	0.15	0.20

For Fuel Oils

Sulfur

up to 1994	3.8 %
1995	3.5 %

For Diesel Oil

up to 1994	0.8 %
1995	0.5 %

TABLE 4.5

DISTRIBUTION OF VEHICLES ACCORDING TO FUEL TYPE (1990)

CARS	Gas	292,527	95.30%
	Diesel	14,432	4.70%
	Total	306,959	
UV	Gas	137,357	54.59%
	Diesel	114,278	45.41%
	Total	251,635	
TRUCKS	Gas	5,898	13.75%
	Diesel	36,994	86.25%
	Total	42,892	
BUSES	Gas	349	6.65%
	Diesel	4,898	93.35%
	Total	5,247	
MOTORTRICYCLES	Gas	66,577	100.00%
	Diesel	0	
	Total	66,577	

Source: DOTC-LTO
MIS Data for 1990

LAND TRANSPORTATION OFFICE

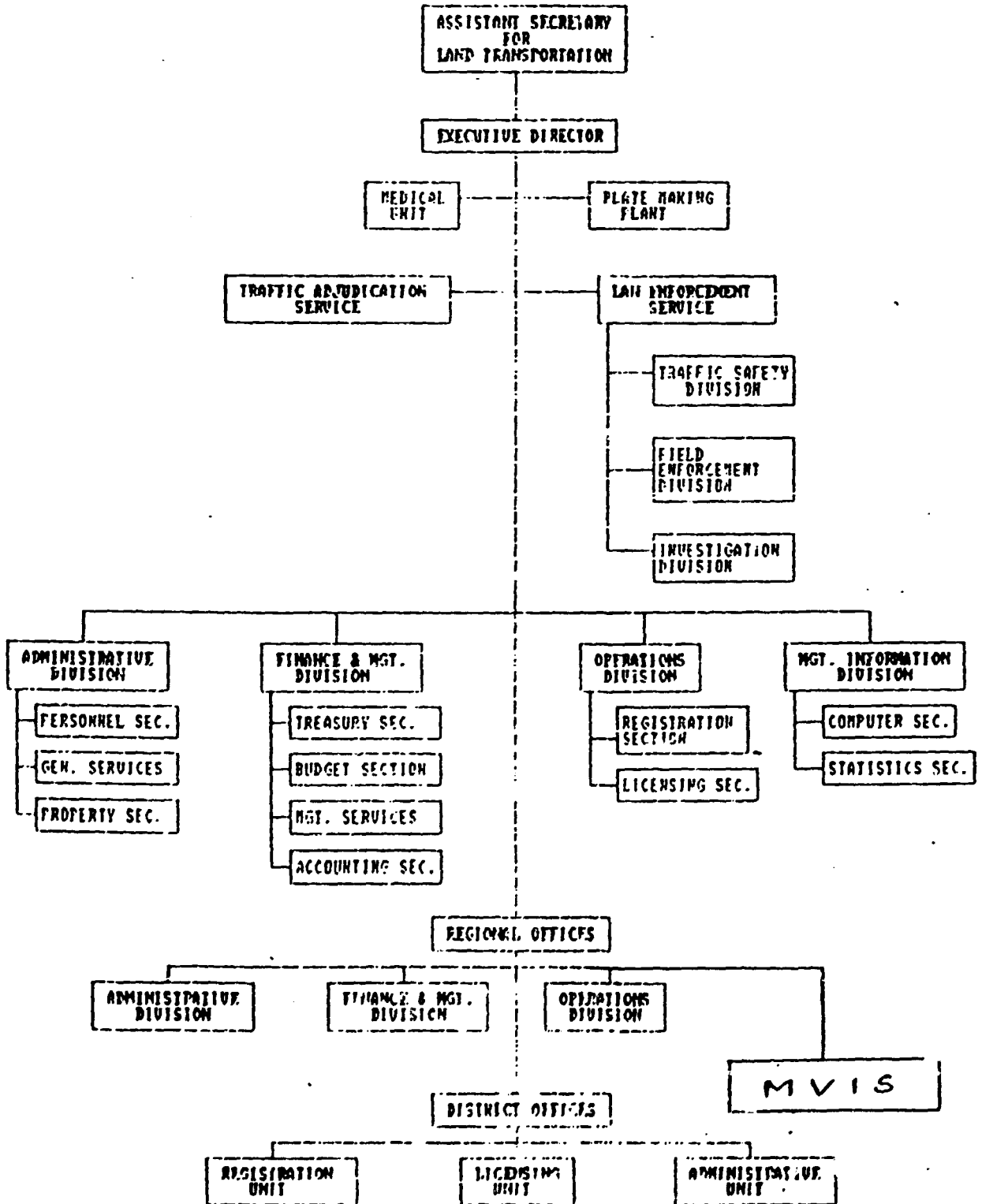

STATUS OF MOTOR VEHICLE POLLUTION CONTROL
IN THE PHILIPPINES
(In- use Motor Vehicle)

Motor vehicle pollution in the Philippines is highly localized. It is commonly found in the cities, like Metro Manila where there is a big volume of traffic. For this reason, pollution control in the country particularly for the in-use vehicles are concentrated in Metro-Manila.

Metro Manila's explosive population increase in recent decades has been accompanied by significant growth in the number of motor vehicles. Metro Manila has become notorious for its extreme traffic congestion and motor vehicles caused air pollution. Diesel powered vehicles, which include cars (primarily taxis), jeepneys, other utility vehicles, buses and trucks make up a major portion of the vehicle kilometer driven. Many of the diesel engines undersized for their loads and characteristically emit large quantities of black smoke (particulate matter). Many of the diesel engines are either worn out or poorly maintained, adding to their tendency to emit air pollutants.

Motor vehicle emissions not only degrade overall urban air quality, in Metro Manila but also expose the cummuting public, comprising a significant portion of the population each business day to the hazards of high doses of air pollutants. The people walking on the streets and sidewalks, those waiting on the streets for public transportation, and those riding in jeepneys and buses likewise receive relatively undilluted concentrations of these motor vehicle exhaust pollutants. The results of the air quality measurements conducted before and during this project in Metro Manila indicate that the public is exposed to ambient particulate matter concentrations of as much as two (2) to three (3) times the accepted standards established to protect health. Pollutants aside from particulate matter, are of less importance, although lead measurements also indicate ambient levels in excess of health based andards.

The Philippine Congress passed Republic Act No. 3931, known as the "Pollution Control Law", in 1964 creating the National Water and Air Pollution Control Commission (NWAPCC). The NWAPCC in 1967 published Rule No: 59, which

limited exhaust emission to a specified Ringleman number (degree of blackness) for no less than a "reasonable period". This law was amended by Presidential Decree No. 984, creating the National Pollution Control Commission (NPCC) which subsequently revised the above rule in 1978 by prescribing visible emission standards for registered diesel-engine. It prohibited visible emission from gasoline vehicles for a continuous period of no more than ten (10) seconds. Recognizing that increasing motor vehicles use was fast becoming a major cause of air pollution in the country, particularly in urban areas, P.D. 1181 was issued in 1977 specifically to control vehicular air pollution. In 1980, P.D. 1181 implementing rules and regulations were promulgated, superseding previous rules. These rules provided revised emission standards for both registered and non-registered, diesel and gasoline-fueled vehicles, i. e., smoke opacity standards for diesel vehicles and carbon monoxide and hydrocarbon exhaust emission standards for gasoline vehicles.

The above latest rules are now enforced by the Department of Environment and Natural Resources (DENR) pursuant to Executive Order No. 192, issued in 1987, integrating the NPCC powers and functions into DENR-Environmental Management Bureau. Presently, enforcement of these rules is done by the DENR/National Capital Region-DENR-NCR (please see Annex 1 for the organizational chart).

The opacity rule, applied almost exclusively to diesel vehicles, is currently enforced by the Anti-Smoking Teams operating out of four (4) offices in Metro-Manila. These teams identify potential offending vehicles, pull them over for a more formal visual check using a Ringlemann Chart, and if the vehicle fails the test, the team issues a ticket instructing the driver to have the vehicle properly tuned-up or repaired, and require the driver to report to the DENR-NCR Motor Vehicle Test Center in Quezon City for final testing using a Hartridge Smoke Meter. Vehicles failing this test are imposed an appropriate penalty and are required to report for re-test before they can receive a Certificate of Compliance. Below is the 15-Year Accomplishment of the Anti-Smoke Belching Campaign.

YEARLY SUMMARY OF ANTI-SMOKE
BELCHING CAMPAIGN
1977-1991

YEAR	No. of Motor Vehicle Apprehension	No. of Motor Vehicle Complied	Penalty Collected
1977	657	319 P	75,800
1978	5,060	1,860	521,200
1979	5,780	1,730	265,400
1980	3,096	809	109,720
1981	9,948	2,173	340,200
1982	18,054	3,543	477,870
1983	16,224	5,366	649,680
1984	12,584	3,160	548,349
1985	13,371	5,297	859,150
1986	7,520	1,726	409,280
1987	9,190	2,047	454,945
1988	2,436	1,484	617,575
1989	26,551	19,592	5,049,175
1990	12,088	16,827	7,554,251
1991	27,781	16,609	4,716,180

**SUMMARY OF STANDARDS AND
TEST PROCEDURES**

I. Non registered Light-duty Gasoline Fueled Vehicle

A. STANDARDS:

Weight GW (Kg.)	CO g/km.	HC g/km.
-----	-----	-----
1,000 or less	25	2.5
1,001 - 1,500	30	3.0
1,501 - 3,000	35	3.5

B. TEST PROCEDURES:

1. CVS System using LA-4 mode of driving
2. ECE Type-1 Test

**II. Non-registered Diesel-Fueled Vehicle
Test Procedures and Standard**

- A. British Standard BS AU 141 (a); 1971
- B. European Economic Community Directive 72/306/EEC Economic Commission for Europe
- C. Australian Design Rule No. 30 Regulation No. 24
- D. U.S.A. EPA Federal Regulations Part 85 or Federal Regulation Part 86
- E. NPCC Rules and Regulations Implementing P.D. 1181
- F. Non-Registered Diesel-Fueled Vehicles with Reconditioned Engines
 1. Test Procedures - Free-Acceleration
 2. Standard - 2.5 m-1 light absorption coefficient

III. Registered Gasoline-Fueled Vehicles

A. STANDARDS:

Inclusive Model Year	Carbon Monoxide Percent	Hydrocarbon ppm
1976 - 1981	4.5	1000
1971 - 1975	5.0	1000
1965 - 1970	5.5	2000
1964 - older	6.0	2000
2 stroke engine	6.0	7800

B. TEST PROCEDURES:

Idling Speed

IV. Registered Diesel-Fueled Vehicles

A. STANDARD:

2.5 m-1 light absorption coefficient

B. TEST PROCEDURE:

Free Acceleration

**PROCEDURE/FLOW CHART FOR
PAYMENT OF PENALTIES AND ISSUANCE OF
COC AND GO FOR SMOKE BELCHING**

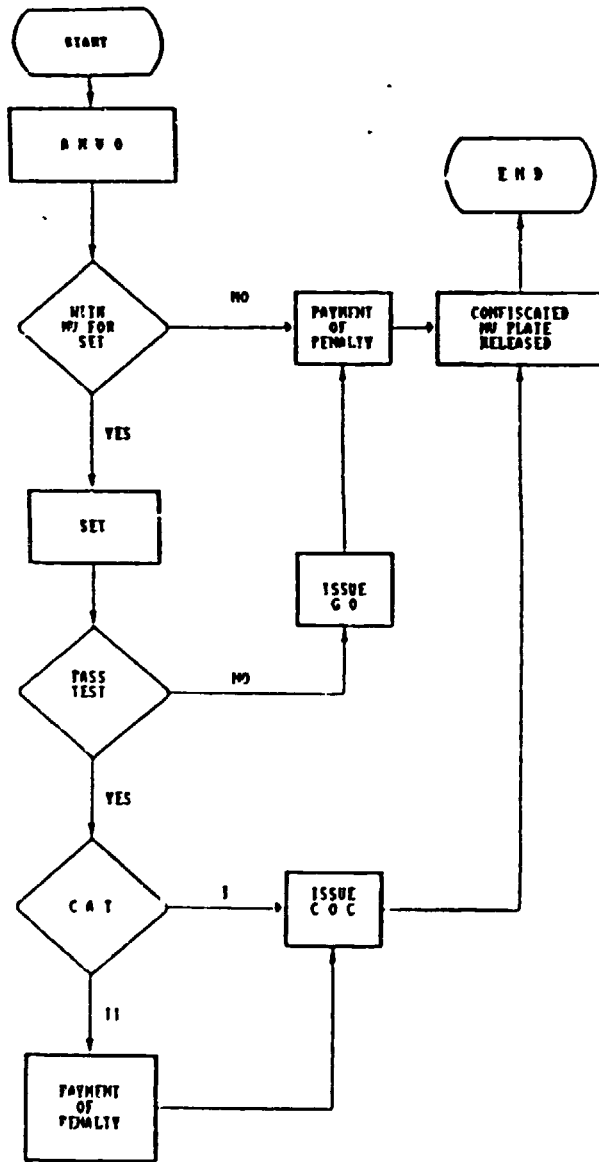

LEGEND:

- A M V O - Apprehended Motor Vehicle Owner
- SET - Smoke Emission Test
- COC - Certificate of Conformity
- GO - Grounding Order
- CAT I - Reported for Testing within 24 hours after apprehension
- CAT II - Reported for Testing after 24 hours after apprehension

STATUS OF MOTOR VEHICLE POLLUTION CONTROL
IN THE PHILIPPINES
(In- use Motor Vehicle)

Motor vehicle pollution in the Philippines is highly localized. It is commonly found in the cities, like Metro Manila where there is a big volume of traffic. For this reason, pollution control in the country particularly for the in-use vehicles are concentrated in Metro-Manila.

Metro Manila's explosive population increase in recent decades has been accompanied by significant growth in the number of motor vehicles. Metro Manila has become notorious for its extreme traffic congestion and motor vehicles caused air pollution. Diesel powered vehicles, which include cars (primarily taxis), jeepneys, other utility vehicles, buses and trucks make up a major portion of the vehicle kilometer driven. Many of the diesel engines undersized for their loads and characteristically emit large quantities of black smoke (particulate matter). Many of the diesel engines are either worn out or poorly maintained, adding to their tendency to emit air pollutants.

Motor vehicle emissions not only degrade overall urban air quality, in Metro Manila but also expose the commuting public, comprising a significant portion of the population each business day to the hazards of high doses of air pollutants. The people walking on the streets and sidewalks, those waiting on the streets for public transportation, and those riding in jeepneys and buses likewise receive relatively undiluted concentrations of these motor vehicle exhaust pollutants. The results of the air quality measurements conducted before and during this project in Metro Manila indicate that the public is exposed to ambient particulate matter concentrations of as much as two (2) to three (3) times the accepted standards established to protect health. Pollutants aside from particulate matter, are of less importance, although lead measurements also indicate ambient levels in excess of health based standards.

The Philippine Congress passed Republic Act No. 3931, known as the "Pollution Control Law", in 1964 creating the National Water and Air Pollution Control Commission (NWAPCC). The NWAPCC in 1967 published Rule No. 59, which

limited exhaust emission to a specified Ringleman number (degree of blackness) for no less than a "reasonable period". This law was amended by Presidential Decree No. 984, creating the National Pollution Control Commission (NPCC) which subsequently revised the above rule in 1978 by prescribing visible emission standards for registered diesel-engine. It prohibited visible emission from gasoline vehicles for a continuous period of no more than ten (10) seconds. Recognizing that increasing motor vehicles use was fast becoming a major cause of air pollution in the country, particularly in urban areas, P.D 1181 was issued in 1977 specifically to control vehicular air pollution. In 1980, P.D. 1181 implementing rules and regulations were promulgated, superseding previous rules. These rules provided revised emission standards for both registered and non-registered, diesel and gasoline-fueled vehicles, i. e., smoke opacity standards for diesel vehicles and carbon monoxide and hydrocarbon exhaust emission standards for gasoline vehicles.

The above latest rules are now enforced by the Department of Environment and Natural Resources (DENR) pursuant to Executive Order No. 192, issued in 1987, integrating the NPCC powers and functions into DENR-Environmental Management Bureau. Presently, enforcement of these rules is done by the DENR/National Capital Region-DENR-NCR (please see Annex I for the organizational chart).

The opacity rule, applied almost exclusively to diesel vehicles, is currently enforced by the Anti-Smoking Teams operating out of four (4) offices in Metro-Manila. These teams identify potential offending vehicles, pull them over for a more formal visual check using a Ringlemann Chart, and if the vehicle fails the test, the team issues a ticket instructing the driver to have the vehicle properly tuned-up or repaired, and require the driver to report to the DENR-NCR Motor Vehicle Test Center in Quezon City for final testing using a Hartridge Smoke Meter. Vehicles failing this test are imposed an appropriate penalty and are required to report for re-test before they can receive a Certificate of Compliance. Below is the 15-Year Accomplishment of the Anti-Smoke Belching Campaign.

**YEARLY SUMMARY OF ANTI-SMOKE
BELCHING CAMPAIGN
1977-1991**

YEAR	No. of Motor Vehicle Apprehension	No. of Motor Vehicle Complied	Penalty Collected
1977	657	349 P	75,800
1978	5,060	1,860	521,200
1979	5,780	1,730	265,400
1980	3,096	809	109,720
1981	9,948	2,173	340,200
1982	18,054	3,543	477,870
1983	16,224	5,366	649,680
1984	12,584	3,160	548,349
1985	13,371	5,297	859,150
1986	7,520	1,726	409,380
1987	9,190	2,047	454,945
1988	2,436	1,484	617,575
1989	26,551	19,592	5,049,175
1990	42,088	16,827	7,554,251
1991	27,781	16,609	4,716,180

**SUMMARY OF STANDARDS AND
TEST PROCEDURES**

I. Non registered Light-duty Gasoline Fueled Vehicle

A. STANDARDS:

Weight GW (Kg.)	CO g/km.	HC g/km.
1,000 or less	25	2.5
1,001 - 1,500	30	3.0
1,501 - 3,000	35	3.5

B. TEST PROCEDURES:

1. CVS System using LA-4 mode of driving
2. ECE Type-1 Test

**II. Non-registered Diesel-Fueled Vehicle
Test Procedures and Standard**

- A. British Standard BS AU 141 (a); 1971
- B. European Economic Community Directive 72/306/EEC Economic Commission for Europe
- C. Australian Design Rule No. 30 Regulation No. 24
- D. U.S.A. EPA Federal Regulations Part 85 or Federal Regulation Part 86
- E. NPCC Rules and Regulations Implementing P.D. 1181
- F. Non-Registered Diesel-Fueled Vehicles with Reconditioned Engines
 1. Test Procedures - Free-Acceleration
 2. Standard - 2.5 m⁻¹ light absorption coefficient

III. Registered Gasoline-Fueled Vehicles

A. STANDARDS:

Inclusive Model Year	Carbon Monoxide Percent	Hydrocarbon ppm
1976 - 1981	4.5	1000
1971 - 1975	5.0	1000
1965 - 1970	5.5	2000
1964 - older	6.0	2000
2 stroke engine	6.0	7800

B. TEST PROCEDURES:

Idling Speed

IV. Registered Diesel-Fueled Vehicles

A. STANDARD:

2.5 m⁻¹ light absorption coefficient

B. TEST PROCEDURE:

Free Acceleration

**PROCEDURE/FLOW CHART FOR
PAYMENT OF PENALTIES AND ISSUANCE OF
COC AND GO FOR SMOKE BELCHING**

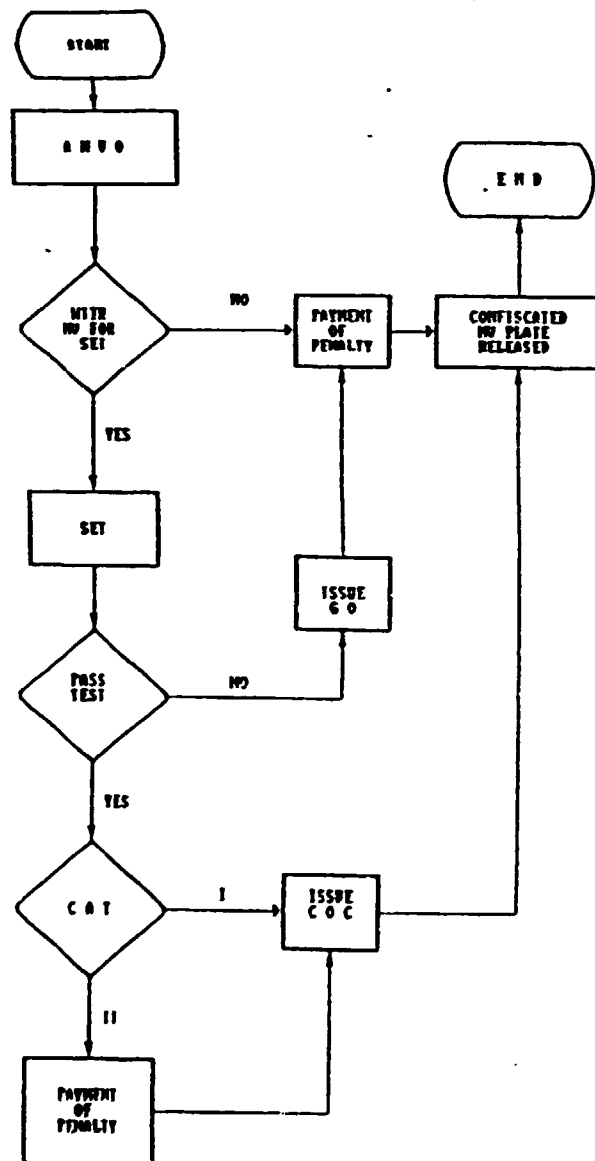

LEGEND:

- AHVO - Apprehended Motor Vehicle Owner
- SFT - Smoke Emission Test
- COC - Certificate of Conformity
- GO - Grounding Order
- CAT I - Reported for Testing within 24 hours after apprehension
- CAT II - Reported for Testing after 24 hours after apprehension

COUNTRY PAPER OF INDONESIA

EXPERT GROUP MEETING ON IN-USE MOTOR VEHICLE INSPECTION
FOR EMISSION CONTROL IN THE ASIA-PACIFIC REGION
SEOUL, REPUBLIC OF KOREA
20-22 OCTOBER 1992

Organized by

United Nations Industrial Development
Organization (UNIDO)

in co-operation with

Korea Institute of Science and Technology (KIST)

Prepared by

DWI WAHYONO SYAMHUDI

DIRECTORATE GENERAL OF LAND TRANSPORT
MINISTRY OF COMMUNICATIONS
REPUBLIC OF INDONESIA

COUNTRY PAPER OF INDONESIA

1. INTRODUCTION

1.1 LAND AND POPULATION

Land

Total the Indonesia's area is 5,193,250 square kilometres, consist of land and sea. Total of land area is 1,919,317 square kilometres. Number of island is around 13,579 islands. The big five are Irian (the western part of Irian), Kalimantan (the major part of the island of Borneo), Sumatera, Sulawesi and Java Island.

Population

Total Indonesia's population is 179,378,946 (Data 1990). Population that live in urban area is 55,433,790 and rural area is 123,813,993. Population distribution and growth by province/island, and population density per square kilometer by province/island can be seen in Table 1 and 2.

1.2 ROAD CONDITIONS

According to the road function, these are classified into 3 classes, they are :

- Arterial road
Arterial road is roads that service high traffic flows to connect main cities or production centres to export harbours or harbour to distribution centre areas.
- Collector road
Collector road is purposed to service middle traffic flows to connect big cities to smaller cities and service the area around.
- Local road
Local area is purposed to service local activity and as connection between isolated area to activity centre in a region.

Based on data of Ministry of Public Work, the total length of road in Indonesia is 50,050 km. Detail data can be seen on Table 3.

1.3 NUMBER OF VEHICLE

The total number of motor vehicle operated on road in 1991 included motor cycle is 9,537,557. The data indicates that the growth rate of motor vehicle number tends to rise in years. In 1991, the growth rate of vehicle number rises 23.37 % compared by 1986. The number of vehicle in 1985 - 1991 can be seen on Table 4.

2. AIR QUALITY STANDARDS AND POLLUTION

2.1 BACKGROUND

A general tendency of rapid urbanization exists in Indonesia are not exempted, especially at 6 (six) big cities in Indonesia, i.e Jakarta, Medan, Semarang, Bandung, Surabaya and Ujungpandang. The urban air pollution problem in many big cities could, to some extent, be correlated to the development of activities in the sectors of transportation and industry, although commercial and residential sectors still contribute significantly.

Examination of available data concerning ambient air quality, vehicle intensity in the roadways, the number and the type of the vehicle in certain period of time and in a certain area where the pollutant concentrations exceed the standard air quality, may provide indication of areas sensitive to air pollution.

The growing demand for better road transportation encourages construction of urban highway and toll road, or access-limited highways of higher standards. However, these have adverse effects on urban life. For example, plans for future expansion of highways and toll road to ease the heavy flow of traffic will encourage more motorists to utilize these roads, increase the amount of noxious fumes emitted from motor vehicle and, in turn, worsen pollution problems already existing in the area.

Jakarta as the biggest and the capital city of Indonesia confronted with various environmental problems, e.g., air and

noise pollution caused in part by proliferation of motor vehicle. Therefore, the Jakarta has been chosen as a first big city to be observed and studied their air quality.

Bearing this in mind, the methodology has considered the temporal and spatial evolution of air pollutant, as it is emitted from the source and dispersed and diffused in the atmosphere. This consideration implies the control method to be selected in preventing air pollution problem. Two simulation models therefore have been developed in this study to simulate the air pollution spatial and temporal characteristics in the urban area. One model deals with micro scale pollution in the roads and highways within the city, and the other will be aimed at identifying the meso scale characteristics of the air pollution problem in the urban area as a whole. The two models consider and were based on the emission and meteorological data as the input. These data were made available during the course of the study.

Using these models, air pollution prediction for a given area or for the whole urban area has been obtained through simulations. Isopleth of each pollutant concentration have been constructed in the regional map. Emphasis has been given to areas suspected as being sensitive, i.e. areas with high intensity of emission or those with dense vehicle volume (vehicle kilometer as basic unit). Assessment of the reliability of the models has been done by means of validation procedures, by which ambient air measurement data acquired from predetermined number of points has been calibrated to those resulted by the models. Correction factors, such as power factor, a new method proposed to be used for air quality modeling, obtained during the validation process has been used to refine the models. Examination of air pollution data both from field measurements and model simulations will provide indications of air pollution condition in the area. This information will eventually lead to determination of monitoring points, either permanent or non permanent.

The modeling results will, on the other hand, provide all necessary and useful information required for the policy analysis in the managemet system of vehicle emission control in Jakarta area.

Isopleth each pollutant in Jakarta is attached.

2.2 POLLUTANTS SOURCES

The main source of air pollution in DKI Jakarta area is assumed to be generated by motor vehicle traffic. The magnitude of influence of this source closely related to the urban activities, i.e. trade and business. The increase of the number of vehicle of about 10 % per year is only one of the reason causing the worsening of pollutant emission. The increase of traffic volume, travel distance and travel time in the area of dense traffic especially in the center of city will be other factors which increase the exhaust emission. The later situation is closely related with the unbalance of the development of infrastructure and transportation system). Due to the uneven distribution of urban activities the traffic tends to concentrate on certain locations. This transportation pattern will cause traffic congestion, so that the magnitude of emission injected in those location, will also increase. That is why spatial distribution of pollutants concentration created in the Jabotabek area is not uniform.

Beside that, concentration of pollutants are caused by industry, solid waste burning and residential area. Increase in activities coming from industrial sector will be accompanied also by the use of energy and commodities traffic. This situation will increase the emission of pollutants especially in industrial areas which in some cases will contribute as specific pollutants emission.

Solid waste burning is a result of increase of population and industries. This activity will contribute to the pollutants emission.

Residential area allows to contribute pollutants emission from the use of commercial energy.

Figure 1 to 4 show the contribution of pollutants emission coming from industry, transportation, residential area and solid waste burning.

Contribution of each sector in detail (figure) can be seen on Table 5 as follows.

TYPE OF POLLUTANT	TOTAL EMISSION TON/YEAR	INDUSTRY (%)	HOUSEHOLD (%)	SOLID WASTE (%)	TRANSPORTATION (%)
CO	325578	0.10	0.10	1.00	98.80
HC	14593	1.20	2.20	7.70	88.90
NOx	20465	15.90	9.60	1.10	73.40
Particulate Matter	7071	14.60	33.10	8.40	44.10
SOx	24710	62.70	10.70	0.20	26.50

2.3 AIR QUALITY STANDARDS

2.3.1 QUALITY STANDARD OF AMBIENT AIR

To control the ambient air, the Government of Indonesia has issued regulations as followed :

- a. Law Number 9 of 1960 on the National Public Health Legislation, regulates the importance of a clean environment, these cover air and water, to the public health.
- b. Law Number 4 of 1982 on The National Environment Legislation, regulates the management of environment in the Republic of Indonesia.
- c. The Decree of State Minister of Population and Environment Number 02/MENKLH/I/1988 which is a directive to regional Authorities in determining the pollutants levels, these cover air, water and sea water in their territories.
- d. The Decree of the Governor of DKI Jakarta Number 587 of 1990 for ambient air quality and noise.

The quality standards of ambient air are presented in Table 6.

2.3.2 MOTOR VEHICLE EMISSION STANDARDS

The motor vehicle emission standards have been issued by Minister of Communications Decree. These regulations are valid to all over Indonesia, they are :

- a. The Decree of Minister of Communications Number KM 483/AJ.401/Phb-84 on April 25, 1984 about roadworthiness inspection of motor vehicle production, trailer, semi trailer, caroseri and its components.

The Decree states that all kind of new vehicle which was imported or assembled in domestic have to get approval of roadworthiness requirements before being produced or imported, including on this roadworthiness requirements is exhaust gas emission inspection.

- c. The Decree of Minister of Communications Number KM 8 of 1989 on February 20, 1989 about requirements of maximum limit of roadworthiness against motor vehicle, trailer, semi trailer and its components. This Decree also states the maximum-level of emission content of Carbon monoxide (CO), Hydrocarbon (HC) and the opacity of smoke of exhaust gas of motor vehicle.

The maximum value/level are as follows :

- The content of CO with premium fuel (\geq 87 RON) is determined maximum 4.5 %
- The content of HC with premium fuel (\geq 87 RON) is determined maximum 1200 ppm.
- The opacity of smoke with diesel fuel (\geq 45 cetane number) is determined maximum 50 %.

- c. The Director General of Land Transport issued the guideline of procedure of roadworthiness inspection for motor vehicle, especially on exhaust gas emission and opacity of smoke.
- d. To implementing the regulation concerning emission and smoke abovementioned, The Governor of DKI Jakarta issued

policy to control pollutant and smoke emitted from motor vehicle.

The maximum levels of these pollutants are presented in Table 7.

3. MOTOR VEHICLE EMISSION AND SMOKE TEST

3.1 EMISSION TEST

According to the Law Number 14 of 1992 about Traffic and Road Transport, all motor vehicles, trailer, semi trailer and special purpose vehicle will be operated on the road compulsory to be inspected. These are including motor vehicle emission and smoke:

Vehicle inspection abovementioned divided into 2, i.e. type approval inspection and regular inspection. Type approval inspection to be done by Directorate General of Land Transport, against each type of new vehicle before the vehicles are produced or imported.

Regular inspection to be done by Local Government twice a year against each vehicle operated on road. For time being vehicle to be inspected limited on public passenger cars, bus, goods motor vehicles, special purpose vehicles, taxis, trailers and semi trailers.

3.2 PROCEDURE OF MOTOR VEHICLE EMISSION INSPECTION

The procedure of motor vehicle exhaust gas emission and smoke inspection has been issued by Director General of Land Transport Decree Number AJ.402/8/5 on September 11, 1990. This procedure is used for type approval inspection and regular inspection, covered inspection procedure of carbon monoxide (CO), hydrocarbon (HC) and opacity of smoke.

The procedure can be explained as followed :

- a. The procedure of testing to measure carbon monoxide (CO) and hydrocarbon in exhaust gas of motor vehicles in idling position

1) Scope

This procedure covers the method to determine the carbon monoxide (CO) and hydrocarbon (HC) content which is contained in exhaust gas of fire ignited internal combustion engines of motor vehicle in the position of idling rotation.

2) Definition

- a) The concentration of CO is the ratio of the volume of carbon monoxide (CO) which is contained in the exhaust gas and expressed in percents (%).
- b) The concentration of HC is the ratio of the volume of hydrocarbon (HC) equalized with normal hexane (C₆H₁₄) in the exhaust gas and expressed in ppm.

3) Test condition

- a) The surrounding condition (outside)
The outside air temperature for the testing vehicles and the measuring (testing) equipment should be around 25 ± 5 °C. The testing equipment should not be exposed to direct heat of the sun, rain or wind.
- b) The condition of the motor vehicle
- (1) The vehicle to be tested should be on a flat place
 - (2) All additional equipment except the standard operational accessories of the engine must be removed and be in a position without load.
 - (3) A vehicle with a normal transmission, the position of the gears must be in neutral and the clutch at a free position.
Vehicles with an automatic transmission, the transfer lever must be at neutral (N) or at position of parking (P).

(4) The engine hood must be in a properly close condition and the additional cooling fan should not be used

c) Preparation of the vehicle to be tested

(1) The propelling engine must first be warmed up to the working temperature.

The choke should not be in operation.

The warming up of propelling engine should be conducted in line with the instructions from the manufacturing plant if such instruction is available in the operating manual or other manuals.

A thermometer or other measuring device should be used to measure whether the working temperature of the engine has been reached, which means that the warming up is sufficient.

(2) The idling rotation of the propelling engine must be stable and the ignition period in line with the specification from the factory.

d) Fuel oil

The fuel oil used fulfill the requirements issued by the Government.

4) Testing equipment

a) The testing equipment must be capable of measuring the CO and HC content continuously at the tested vehicle in idle rotation.

b) The operation of the testing equipment must adhere to the procedure of operating the testing equipment.

5) Testing procedure

a) Investigate whether there is a leakage at the propelling engine exhaust gas system and the testing equipment.

b) After the warming up has been completed, the rotation of the engine should be increased to the medium rotation during 15 minutes without load and then back to the idling rotation.

- c) Immediately after the rotation of the engine has returned to the idling, attach the equipment (probe) into the exhaust gas disposal pipe as deep as 30 cm.

After approximately 20 seconds, the measurement of the CO and HC content can be carried out in line with the SOP of the testing equipment.

If the vehicle has 2 or 3 exhaust gas disposal pipes, it should be arranged that the exhaust gas is discharged through 1 pipe.

If the disposal can not be made through 1 pipe, the measurement must be conducted at each disposal pipe, in this way, the connection must be calculated by way of finding the average value.

Notes :

- a) In 4 stroke engine, the probe must be placed minimum 30 cm inside the exhaust gas pipe, in so far as the testing is not influenced by the surrounding air.

- b) If the probe can not be placed inside the exhaust gas pipe as required, then we must extend the exhaust gas pipe.

- b. The procedure for measuring the opacity diesel of smoke content of motor vehicles

1) Scope

This procedure explains the steps of testing the opacity of smoke content of diesel motor vehicles at a stationary rotation.

2) Testing condition

- a) Condition of the propelling engine and test vehicle.

- (1) The seal on the engine must be in accordance with the factory specifications.
(2) The exhaust gas system must not be leaking.

- (3) Before being warmed up until the working temperature in line with the specifications of the manufacturing factory, in particular, the cooling water and oil must reach the working temperature determined by the manufacturing factory requirements.

The warming up of the propelling engine should be carried out in line with the instructions of the manufacturing factory, if it is available in the operating manual or in another manual for the propelling engine.

The thermometer or other measuring equipment used for measuring whether the working temperature of the propelling engine has been reached, in the meaning of the warming up is sufficient.

b) Fuel oil

The fuel oil used must fulfill the requirements issued by the Government.

c) Testing equipment

- (1) The equipment is constructed in such a way that it is capable of sucking exhaust gas as much as (330 ± 15) ml within 1.4 ± 0.2 seconds through a filter paper.

- (2) The installation of the probe in the exhaust gas pipe must be parallel to the axis of the pipe. If it is impossible for the probe to be parallel, an addition must be used.

- (3) The quality of the filter paper used must be in line with the class 5A filter paper shown at JIS P3801 or the equivalent.

- (4) To know the opacity of the filter paper and to ensure the reflection of the smoke tester in line with the type Bosch (JIS D8004). The calibration of the smoke meter is carried out in line with the requirements issued by the manufacturing factory of the equipment as an example of the deflection type.

d) Condition of the testing place

The absolute temperature of the testing place (T) expressed in degrees/kelvin and the atmospheric pressure H expressed in mm Hg must be measured and the factor F can be calculated with the formula :

$$F = (750/H)^{0.65} \times (T/298)^{0.5}$$

To measure the value of F as correcting factor of the testing place can be taken : $0.98 < F > 1.02$.

3) Testing procedure

- a) The transmission transfer lever must be place at the neutral position, and the position of the clutch must be free.
- b) Before starting the measurements, clean the disposal system by pressing the accelerator 2 or 3 times without load.
- c) After the cleaning as mentioned in point 2 above, leave the propelling engine at an idle rotation during 5 to 6 seconds, and then press the accelerator pedal slowly so that there will be maximum injection from the injection pump.

This condition is maintained 4 seconds so that a maximum rotation will be reached and the governor will be working.

After 4 seconds release the accelerator pedal and the engine will return to idle rotation and leave it until the subsequent measurement.

The period of each measurement must be 15 seconds. The working of the gas collection by the equipment started simultaneously with start of the working of the accelerator pedal so that the equipment will collect the exhaust gas when the accelerator pedal is pressed down.

- d) The measurement is repeated 3 times and for each measurement must be used a new filter paper.

e) The sequence of the exhaust gas measuring shall be conducted.

4) Test results

The opacity of the 3 pieces filter paper during the testing, the average value is taken and final result obtained by comparing it with the value limit.

4. AUTOMOTIVE FUELS

The automotive fuels in Indonesia can be classified into 3 categories :

- a. Gasoline
- b. Diesel fuel
- c. Gas fuels

Gasoline

Gasoline is fuel for otto engine. It can be classified based on octane number. The fuel of standard octane 100 is 2,2,4 trimetil-pentana and the fuel of standard octane 0 is n-heptana. The number of octane in gasoline that is used mostly is between 85 to 95. Some gasoline premium have octane number more than 100. It is the result of using lighter hydrocarbon and or adding additive substances such as tetraetil lead (TEL).

Table 8 presents typical test figure of commercial gasoline (premium) in Indonesia.

Diesel Fuel

Standard fuel for diesel vehicle/motor is classified into octane number. Its cetane 100 standard is n-heksaoktana (C₁₆H₃₄), sometimes called n-cetane and standard cetane 0 is alfa-metilnaf-talena (C₁₁H₂₀). Most of diesel fuel have cetane number beteen 30 to 60. Quality of the burning of diesel fuel can be determined by adding few certain chemical substance like organic nitrates and peroxide i.e amylnitrate, acetoperoxide. Addition of 0.5 % - 4 % amylnitrate will rise cetane number 7 to 30 and addition of 0.5 % - 4 % acetoperoxide will rise cetane number 10 - 35.

Table 9 presents the Indonesia specification for diesel

fuels (PERTAMINA).

5. PROPOSAL TO MINIMIZE AIR POLLUTION DUE TO MOTOR VEHICLES

To minimize air pollution due to motor vehicles, there are many actions can be done. The actions that proposed to minimize air pollution are as follows :

1) Relating to engine of motor vehicle

a. The engines must be good conditions, i.e

- The ignition system should be tuned properly according to factory specification, otherwise bad combustion will result
- Air filter must be cleaned. A dirty filter may choke air inlet
- The driving style should be improved; less acceleration and deceleration. Acceleration needs extra power, thus producing more pollutants.
- The use of wide thread tires should be discouraged, for examp'e by special taxation.

b. Fundamental changes on the engines

- The use of conventional two cycle engine vehicles should be minimized.
- Fuel injection system for gasoline engines is better than carburetor, and therefore the use of it must be encouraged.
- Improved design, closer manufacturing tolerances and accurate adjustments are necessary for any components which affect combustion, viz. carburetor or injection system; inlet manifold; combustion chamber; cam profile and valve timing; all ignition components.
- The heavier the vehicle, and the bigger its engine, the more likely it is for the need of other control devices to meet HC and NOx limitations.

- 2) Alternative policies on city mass transportation
- a. Replacing diesel or gasoline engines used as prime movers for city mass transport (busses) by electric motors to become electric trolley busses, or even electric train commuting on elevated railway system; it has the advantages of :
 - Free from road traffic
 - Large carrying capacity
 - Fast
 - Air pollution free
 - More economical (one third of the fuel consumption per ton kilometer of conventional bus)
 - b. Promoting the use of smaller and lighter motor vehicles in the city by drastic changes in the vehicle taxation system.
 - c. Improving other communications facilities (telephone, telefax) to reduce people leaving their domiciles by driving cars to meet each others, thus saving fuels, reducing traffic load and air pollution.
- 3) The quality of fuels has an important role in the exhaust gas pollutant constituent and content, and are influenced by :
- a. Fuel volatility, which affects the richness of the fuel/air mixture, its homogeneity and also on its repartition in each cylinder.
 - b. Chemical composition of fuel, which influences the nature of pollutants constituent and content.
 - c. TEL content, which may produce lead containing particulates.
 - d. The use of multifunctional additives, which may produce new pollutant to be observed.
- 4) The use gaseous fuel (Compressed Natural Gas or Liquefied Petroleum Gas) instead of gasoline or diesel fuel

Almost any conventional motor vehicle can be converted to gas fuel operation which will contribute to decreasing the air pollution. The most common of such a conversion is the

conversion to CNG (compressed natural gas). Typically a 90 % reduction in CO and a 40 % in HC (from that of gasoline) is expected to be achieved when the conversion system is tuned correctly. Since the gas fuel is in a gaseous state when entering the carburetor the fuel-air mixture are more uniform than gasoline, thus allowing the engine to run on much leaner mixtures. The repartition of the charge to the cylinders is more uniform and the combustion is expected to be more complete.

Using of CNG in high millege city fleets not only will help to reduce air pollution in areas where the pollution levels are already high, but it has also an advantage of gaining premium due to its lower price.

6. CONCLUSIONS

From the explanation abovementioned, it can be concluded that :

- a. The biggest contribution against pollution in several big cities of Indonesia especially in Jakarta due to exhaust gas and smoke of motor vehicle.
- b. Generally level of air ambient pollution as well as emission in Indonesia are still below quality standard. However this level will increase and increase rapidly, and at certain area of big cities have already exceeded. Therefore it must be handled and controlled early to prevent level of air pollution exceeding air quality standards.
- c. Maximum limit of pollutants of motor vehicle exhaust gas have already determined by Ministry of Communications. Therefore all motor vehicle operated on road must fulfill these limit.
- d. To control and minimize air pollution due to motor vehicle there are many actions to be done, i.e :
 - Good maintenance of motor vehicle
 - Improve engine technology
 - Using better fuel quality
 - Improve mass transportation especially in urban area
 - Using additional equipment to reduce emission and smoke level

TABEL
1
Table

PERSEBARAN PENDUDUK INDONESIA DAN PERTUMBUHANNYA
MENURUT PROPINSI/PULAU
Population Distribution and Growth by Province/Island

1971, 1980 & 1990

PROPINSI/PULAU Province/Island	Penduduk/Population *) (x 1 000)						Rata-rata Pertumbuhan Penduduk/Average Annual Population Growth	
	1971		1980		1990		1971-1980 (%)	1980-1990 (%)
	Penduduk/ Population	%	Penduduk/ Population	%	Penduduk/ Population	%		
(1)	(2)	(3)	(4)	(5)	(6)	(7)	(8)	(9)
1. Jawa-Madura	76 086,3	63,0	91 269,5	61,9	107 581,4	60,0	2,02	1,66
a. DKI Jakarta	4 579,3	3,8	6 503,4	4,4	8 259,3	4,6	3,93	2,47
b. Jawa Barat	21 623,5	18,1	27 453,5	18,6	35 384,4	19,8	2,66	2,59
c. Jawa Tengah	21 887,1	18,4	25 372,9	17,2	28 520,6	15,9	1,64	1,16
d. D.I. Yogyakarta	2 489,4	2,1	2 750,8	1,9	2 913,1	1,6	1,10	0,35
e. Jawa Timur	25 517,0	21,4	29 188,9	19,8	32 504,0	18,1	1,49	1,08
2. Sumatra	20 808,1	17,5	28 016,2	19,0	36 506,7	20,3	3,32	2,71
3. Kalimantan	5 154,8	4,4	6 723,1	4,5	9 099,9	5,1	2,96	3,11
4. Sulawesi	8 526,9	7,1	10 409,5	7,1	12 520,7	7,0	2,22	1,86
5. Kepulauan Lain/ Other Islands	8 632,1	7,2	11 072,0	7,5	13 670,2	7,6	2,77	2,05
INDONESIA	119 208,2	100,0	147 490,3	100,0	179 378,9	100,0	2,32	1,97

*) Termasuk penduduk tidak bertempat tinggal tetap (tuna wisma, awak kapal, penghuni perahu/rumah apung dan masyarakat terpencil).
Including non permanent resident (homeless people, sailor, boat people and remote area community).

TABEL
: 2
Table

KEPADATAN PENDUDUK PER KILOMETER PERSEGI
MENURUT PROPINSI/PULAU
Population Density per Square Kilometer by Province/Island

1971, 1980 & 1990

PROPINSI/PULAU Province/Island	Luas (Km ²)/ Area (sq.km)	Persentase/ Percentage	Kepadatan Penduduk Per Kilometer/ Population Density per sq.km.		
			1971	1980	1990
(1)	(2)	(3)	(4)	(5)	(6)
1. Jawa-Madura	132 186	6,89	576	690	814
a. DKI Jakarta	661	0,03	7 796*)	11 017*)	12 495
b. Jawa Barat	46 229	2,41	466*)	592*)	765
c. Jawa Tengah	34 206	1,70	640	742	833
d. D.I. Yogyakarta	3 169	0,17	789	884	915
e. Jawa Timur	47 921	2,50	532	609	670
2. Sumatra	473 481	24,67	44	59	77
3. Kalimantan	539 460	28,11	10	12	17
4. Sulawesi	189 216	9,85	45	55	66
5. Kepulauan Lain/ Other Islands	584 974	30,48	15	19	23
INDONESIA	1 919 317	100,00	62	77	93

*) Kepadatan penduduk sebelum perubahan luas wilayah (DKI Jakarta 590 Km² dan Jawa Barat 46.300 Km²).
Population density before expanded (DKI Jakarta 590 Km² and Jawa Barat 46,300 Km²).

TABLE 3 :TOTAL LENGTH OF ROAD THROUGHOUT INDONESIA
ACCORDING TO ITS FUNCTION AS ARTERIAL
COLLECTOR AND LOCAL ROAD.

NO.	PROVINCE	TOTAL (Km)	FUNCTION OF ROAD		
			ARTERIAL (Km)	COLLECTOR (Km)	LOCAL (Km)
1	DISTA. ACEH	2,087.65	778.80	1,220.59	88.26
2	SUMATERA UTARA	3,612.71	633.51	2,835.63	93.57
3	SUMATERA BARAT	1,860.25	381.90	1,455.51	22.84
4	R I A U	1,975.57	275.16	1,700.41	0.00
5	J A M B I	1,601.01	124.45	1,467.74	8.82
6	BENGKULU	970.71	186.46	784.25	0.00
7	SUMATERA SELATAN	3,265.08	621.63	2,568.47	74.98
8	LAMPUNG	1,723.30	343.27	1,356.32	23.71
9	D.K.I JAKARTA	56.10	56.10	0.00	0.00
10	JAWA BARAT	3,053.89	674.17	2,271.13	108.59
11	JAWA TENGAH	2,857.36	625.66	2,204.07	27.63
12	D.I YOGYAKARTA	498.12	70.87	384.60	42.65
13	JAWA TIMUR	3,614.63	622.33	2,732.84	258.96
14	KALIMANTAN BARAT	2,271.85	491.53	1,780.27	0.00
15	KALIMANTAN TENGAH	943.17	118.79	824.38	0.00
16	KALIMANTAN TIMUR	1,297.56	115.00	1,166.56	16.00
17	KALIMANTAN SELATAN	1,037.17	275.56	811.61	0.00
18	B A L I	795.57	306.90	446.27	42.40
19	NUSATENGGA BARAT	1,189.43	356.91	813.61	18.91
20	NUSATENGGA TIMUR	2,720.67	592.09	1,823.55	305.03
21	TIMOR TIMUR	1,301.38	138.02	1,163.36	0.00
22	SULAWESI UTARA	1,748.04	489.99	1,234.03	24.02
23	SULAWESI TENGAH	2,581.50	235.74	2,415.08	30.68
24	SULAWESI SELATAN	2,572.06	550.44	1,969.16	52.46
25	SULAWESI TENGGARA	1,081.39	169.39	843.45	69.01
26	MALUKU	1,581.49	381.38	1,160.70	39.41
27	IRIAN JAYA	1,601.84	648.40	934.44	19.00
TOTAL INDONESIA		50,050.00	10,315.00	38,368.07	1,366.93

Source : Ministry of Public Work, 1991

TABLE 4 : TOTAL NUMBER OF MOTOR VEHICLE THROUGHOUT
INDONESIA ACCORDING TO ITS TYPE

No.	PROVINCE	1985	1986	1987	1988	1989	1990	1991
1	D.I. ACEH	122,256	131,395	139,459	141,930	149,521	154,036	158,000
			6.96%	5.78%	1.74%	5.08%	2.96%	2.48%
	Passenger Car	6,715	7,340	10,598	13,511	12,793	13,400	13,867
			8.51%	30.74%	21.75%	-5.86%	4.53%	3.37%
	Bus	3,632	4,093	1,706	1,493	1,867	2,063	2,354
			11.26%	-159.92%	-14.27%	20.03%	9.50%	12.36%
	Goods Vehicle	12,403	12,826	14,432	12,570	15,650	16,179	16,456
			3.30%	11.13%	-14.81%	19.68%	3.27%	1.68%
	Motor Cycle	99,506	107,136	112,724	114,324	119,211	122,444	125,323
			7.12%	4.96%	1.40%	4.10%	2.64%	2.30%
2	SUMATERA UTARA	514,201	542,557	594,991	631,438	657,061	686,018	730,650
			5.23%	8.31%	5.77%	3.90%	4.22%	6.11%
	Passenger Car	46,775	50,424	56,068	66,414	72,824	60,899	63,640
			7.24%	10.07%	15.58%	8.80%	-19.58%	11.23%
	Bus	24,647	27,974	30,016	30,551	33,335	35,496	37,721
			11.89%	6.80%	1.75%	8.35%	6.09%	5.90%
	Goods Vehicle	62,537	65,501	68,059	72,037	76,917	83,096	85,935
			4.53%	3.76%	5.59%	6.28%	7.44%	3.30%
	Motor Cycle	380,242	398,628	440,848	462,356	474,005	506,527	528,354
			4.63%	9.56%	4.66%	2.45%	6.42%	5.91%
3	SUMATERA BARAT	140,767	150,516	159,224	137,094	142,804	149,862	156,452
			6.48%	5.47%	-16.14%	4.00%	4.71%	-4.21%
	Passenger Car	14,174	15,776	17,376	11,694	12,128	12,872	14,326
			10.15%	9.21%	-48.59%	3.58%	5.78%	10.15%
	Bus	6,148	6,794	7,763	9,097	10,121	11,442	12,756
			9.51%	12.48%	14.66%	10.12%	11.55%	10.58%
	Goods Vehicle	20,124	21,417	23,300	21,557	22,471	23,769	25,548
			6.04%	8.08%	-8.09%	4.07%	5.46%	6.96%
	Motor Cycle	100,321	106,529	110,785	94,746	98,084	101,779	103,782
			5.83%	3.84%	-16.93%	3.40%	3.63%	1.93%
4	RIAU	132,902	142,744	155,967	167,134	144,480	158,242	166,112
			6.90%	8.43%	6.68%	-15.68%	8.70%	4.74%
	Passenger Car	11,452	13,009	15,507	17,271	11,869	14,224	15,119
			11.97%	16.11%	10.21%	-45.51%	16.56%	5.92%
	Bus	1,823	2,103	2,750	3,241	3,478	4,354	4,827
			13.31%	23.53%	15.15%	6.81%	20.12%	9.71%
	Goods Vehicle	15,007	16,304	17,720	19,054	11,059	13,352	14,596
			7.96%	7.99%	7.00%	-72.29%	17.17%	8.52%
	Motor Cycle	104,620	111,328	119,990	127,568	118,075	126,311	131,575
			6.03%	7.22%	5.94%	-8.24%	6.52%	4.00%

5	SUMATERA SELATAN (1)	476,627	521,669	606,573	643,462	658,229	676,064	692,198
			8.63%	13.97%	5.76%	2.24%	2.54%	2.33%
	Passenger Car	48,750	55,729	71,541	78,071	79,980	83,362	86,209
			12.52%	22.10%	8.56%	2.59%	4.06%	3.30%
	Bus	13,585	14,022	29,385	30,334	31,349	31,886	33,296
			3.12%	53.03%	3.08%	1.64%	1.63%	4.23%
	Goods Vehicle	72,175	73,745	86,520	99,793	101,751	104,617	107,142
			2.13%	14.77%	13.30%	1.92%	2.74%	2.36%
	Motor Cycle	342,117	378,173	418,426	434,764	445,149	456,199	465,551
			9.53%	9.62%	3.76%	2.33%	2.42%	2.01%
6	DKI JAKARTA	1,236,608	1,374,896	1,384,461	1,435,731	1,515,299	1,649,037	1,795,090
			3.62%	3.58%	3.57%	5.25%	8.11%	8.14%
	Passenger Car	340,177	356,188	379,076	398,869	434,659	485,844	534,210
			4.50%	6.04%	4.96%	8.23%	10.54%	9.05%
	Bus	99,078	111,147	124,840	136,851	150,077	169,027	191,973
			10.86%	10.97%	8.78%	8.31%	11.21%	11.95%
	Goods Vehicle	149,781	154,498	159,749	164,331	175,170	189,980	208,851
			3.05%	3.29%	2.79%	5.10%	8.85%	9.04%
	Motor Cycle	697,572	713,063	720,796	735,680	757,393	804,186	860,056
			2.17%	1.07%	2.02%	2.87%	5.82%	6.50%
7	JAWA BARAT	847,402	885,986	785,319	793,869	788,774	847,100	887,795
			4.55%	-12.52%	1.08%	-0.65%	6.89%	4.58%
	Passenger Car	160,147	169,251	151,160	148,728	155,120	170,573	176,436
			5.40%	-11.99%	-1.64%	4.12%	9.22%	3.15%
	Bus	25,797	25,672	31,808	40,552	39,604	49,295	49,714
			10.03%	9.56%	21.56%	-2.39%	19.66%	0.84%
	Goods Vehicle	157,293	140,216	120,353	111,547	111,706	120,610	125,568
			2.05%	-15.01%	-8.55%	0.32%	7.38%	3.95%
	Motor Cycle	524,165	547,817	481,488	493,242	482,344	506,322	536,077
			4.32%	-13.78%	2.35%	-2.26%	4.74%	5.55%
8	JAWA TENGAH (2)	965,109	1,035,258	1,062,296	1,131,667	1,371,386	1,395,367	1,470,845
			6.78%	2.55%	6.13%	17.48%	1.72%	5.13%
	Passenger Car	92,289	99,571	101,303	111,565	141,608	148,859	157,151
			7.31%	1.71%	9.20%	21.22%	4.87%	5.28%
	Bus	14,337	15,521	15,484	16,688	18,741	20,135	22,723
			7.63%	-0.24%	7.21%	10.95%	6.92%	11.39%
	Goods Vehicle	98,507	104,180	100,511	106,118	125,421	137,122	144,172
			5.45%	-3.65%	5.28%	15.39%	8.53%	4.89%
	Motor Cycle	759,976	815,936	844,998	897,296	1,085,616	1,089,251	1,146,799
			6.86%	3.43%	5.83%	17.35%	0.33%	5.02%

9	JAWA TIMUR	1,320,427	1,439,241	1,348,059	1,470,866	1,519,429	1,711,613	1,977,612
			8.26%	-6.76%	3.55%	3.20%	11.23%	13.45%
	Passenger Car	164,155	184,218	91,572	109,088	121,960	149,940	182,431
			10.59%	-101.17%	16.06%	10.55%	15.66%	17.81%
	Bus	7,875	11,440	53,386	52,497	98,905	100,062	102,137
			31.16%	78.57%	35.29%	16.59%	1.16%	2.03%
	Goods Vehicle	138,122	145,002	131,368	144,075	146,929	158,429	183,770
			4.74%	-10.38%	8.82%	1.94%	7.26%	13.79%
	Motor Cycle	1,010,275	1,098,581	1,071,733	1,135,205	1,151,635	1,303,182	1,509,274
			8.04%	-2.51%	5.59%	1.43%	11.63%	13.66%
10	BALI (3)	255,407	278,878	317,446	338,554	374,540	442,037	475,851
			8.42%	12.15%	6.23%	9.61%	15.27%	7.11%
	Passenger Car	22,752	23,230	28,901	34,607	40,644	47,472	52,692
			2.06%	19.62%	16.49%	14.85%	14.35%	9.91%
	Bus	6,169	6,535	6,719	6,270	7,369	8,390	7,957
			9.74%	-1.73%	-7.16%	14.91%	12.17%	-5.44%
	Goods Vehicle	30,091	32,553	36,275	37,472	40,744	46,595	45,569
			7.51%	10.32%	3.19%	8.03%	12.56%	-2.25%
	Motor Cycle	196,395	216,280	245,545	260,205	285,783	339,580	369,643
			9.19%	11.92%	5.63%	8.95%	15.84%	8.13%
11	KALIMANTAN BARAT	73,881	81,747	87,987	100,667	111,450	119,475	130,875
			9.62%	7.09%	12.60%	9.68%	6.72%	8.71%
	Passenger Car	4,685	5,274	6,032	8,751	9,390	10,209	11,289
			11.17%	12.57%	31.07%	6.81%	8.02%	9.57%
	Bus	2,346	2,874	2,915	2,183	2,263	2,172	2,289
			18.37%	1.41%	-33.53%	3.54%	-4.19%	5.11%
	Goods Vehicle	5,856	6,471	7,515	8,402	9,174	9,530	10,637
			9.50%	13.89%	10.56%	8.42%	3.74%	10.41%
	Motor Cycle	60,994	67,128	71,525	81,331	90,623	97,564	106,660
			9.14%	6.15%	12.06%	10.25%	7.11%	8.53%
12	KALIMANTAN SELELATAN (4)	104,570	137,962	153,285	162,468	170,999	189,482	202,600
			24.20%	10.00%	5.65%	4.99%	9.75%	6.47%
	Passenger Car	12,207	12,184	15,011	15,719	16,485	24,979	27,081
			-0.19%	18.83%	4.50%	4.65%	34.00%	7.76%
	Bus	4,905	757	817	921	1,024	902	2,091
			-547.95%	7.34%	11.29%	10.06%	-13.53%	56.86%
	Goods Vehicle	9,441	9,507	11,404	12,314	13,088	18,154	20,549
			0.69%	16.63%	7.39%	5.91%	27.91%	11.66%
	Motor Cycle	78,017	115,519	126,053	133,514	140,402	145,447	152,878
			32.46%	8.36%	5.59%	4.91%	3.47%	4.86%

13	KALIMANTAN TIMUR	111,333	110,069	114,593	121,102	128,331	139,359	141,591
			-1.60%	3.95%	5.37%	6.04%	7.52%	1.58%
	Passenger Car	12,635	11,995	11,959	13,142	14,170	17,413	15,746
			-5.34%	-0.30%	9.00%	7.25%	18.62%	7.11%
	Bus	5,058	5,221	5,851	6,092	6,452	5,404	5,211
			3.12%	10.77%	3.96%	5.58%	-19.39%	-3.70%
	Goods Vehicle	15,755	15,917	16,276	17,574	18,516	19,599	19,821
			1.02%	2.21%	7.39%	5.09%	5.53%	1.12%
	Motor Cycle	78,385	76,936	80,507	84,294	89,743	96,943	97,813
			-1.88%	4.44%	4.49%	6.07%	7.43%	0.89%
14	SULAWESI UTARA (5)	104,312	119,723	119,234	111,241	137,015	152,097	136,052
			12.46%	-0.37%	-7.23%	18.81%	-3.72%	2.91%
	Passenger Car	14,248	16,961	15,752	17,672	22,137	19,526	20,192
			16.00%	-7.68%	10.36%	20.17%	-13.37%	3.30%
	Bus	4,965	6,581	6,702	5,658	10,403	7,784	8,233
			24.56%	1.81%	-18.45%	45.61%	-33.65%	5.45%
	Goods Vehicle	14,997	16,712	15,335	17,513	24,552	20,065	21,313
			10.26%	-5.54%	9.58%	28.67%	-22.36%	5.96%
	Motor Cycle	70,602	79,473	80,995	70,398	79,922	84,723	86,314
			11.16%	1.85%	-15.05%	11.92%	5.67%	1.84%
15	SULAWESI SELATAN (6)	302,633	324,100	333,846	306,818	316,200	330,561	343,040
			6.62%	2.92%	-8.31%	2.97%	4.34%	3.64%
	Passenger Car	27,570	29,569	30,881	18,717	20,258	24,901	28,341
			6.76%	4.25%	-64.99%	7.61%	18.65%	12.14%
	Bus	8,487	9,402	10,772	9,002	9,854	10,315	11,865
			9.73%	12.72%	-19.66%	8.65%	3.89%	8.35%
	Goods Vehicle	27,532	50,509	51,823	38,849	40,754	22,421	45,698
			5.89%	2.54%	-33.43%	4.70%	3.93%	2.92%
	Motor Cycle	219,044	234,620	240,370	240,260	245,334	252,424	259,136
			6.64%	2.39%	-0.05%	2.07%	2.81%	2.59%
16	MALUKU	26,386	30,988	21,278	23,271	23,266	26,202	27,183
			14.85%	-45.63%	8.57%	-0.02%	11.20%	3.61%
	Passenger Car	1,826	2,173	1,715	2,157	1,157	3,006	3,290
			15.97%	-26.71%	20.49%	-86.43%	61.51%	8.63%
	Bus	854	921	772	851	4,817	5,277	1,205
			7.27%	-19.30%	9.28%	82.33%	8.72%	-337.93%
	Goods Vehicle	5,495	6,290	4,485	4,317	851	1,110	5,589
			12.64%	-40.25%	6.89%	-466.04%	23.33%	80.14%
	Motor Cycle	18,211	21,604	14,307	15,446	16,446	16,808	17,101
			15.71%	-51.00%	7.37%	6.08%	2.15%	1.71%

No.	PROVINCE	1985	1986	1987	1988	1989	1990	1991
17	IRAIN JAYA	37,276	40,666 8.34%	42,305 3.87%	44,113 4.10%	44,147 0.08%	44,138 -0.02%	45,599 3.20%
	Passenger Car	6,632	6,929 4.29%	6,390 -0.57%	7,098 2.93%	7,059 -0.55%	6,056 -16.56%	6,157 1.32%
	Bus	1,757	2,217 20.75%	2,228 0.49%	2,950 24.47%	2,302 -26.15%	4,127 44.22%	4,625 10.83%
	Goods Vehicle	4,212	4,456 5.48%	4,742 6.03%	4,717 -0.53%	4,546 -3.76%	4,729 3.87%	5,129 7.64%
	Motor Cycle	24,675	27,064 8.83%	25,445 4.85%	29,348 3.08%	30,240 2.95%	29,226 -3.47%	29,714 1.64%
	INDONESIA	6,823,677	7,308,433 6.64%	7,426,175 1.59%	7,761,427 4.32%	8,253,564 5.96%	8,550,743 6.75%	9,537,557 7.20%
	Passenger Car	987,139	1,059,851 6.86%	1,011,342 -4.80%	1,073,106 5.76%	1,174,241 8.61%	1,293,835 9.24%	1,416,157 8.64%
	Bus	231,463	256,574 9.79%	334,414 23.28%	385,731 13.30%	431,961 10.70%	468,631 7.82%	501,015 6.46%
	Goods Vehicle	539,328	876,084 4.20%	870,830 -0.60%	892,581 2.43%	937,299 4.77%	1,009,357 7.14%	1,084,334 6.91%
	Motor Cycle	4,765,117	5,115,925 6.56%	5,209,538 1.80%	5,410,007 3.71%	5,710,005 5.25%	6,078,916 6.07%	6,556,050 6.99%

- (1) Including Province of Jambi, Bengkulu and Lampung
- (2) Including Province of Yogyakarta
- (3) Including Province of Nusa Tenggara Barat, Nusa Tenggara Timur and Timor Timur
- (4) Including Province of Kalimantan Tengah
- (5) Including Province of Sulawesi Tengah
- (6) Including Province of Sulawesi Tenggara

Source :

Directorate of Traffic, Police Department, Republic of Indonesia, April 1992.

TABLE 6 :

QUALITY STANDARD OF AMBIENT AIR

NO	PARAMETER	MEASUREMENT TIME	QUALITY STANDARD	ANALYSIS METHODS	EQUIPMENT	REMARKS
1.	Sulfur dioksida (SO ₂)	24 jam	0,10 ppm (160. µg/m ³)	Parasoulita	Spektrophotometer	
2.	Karbon monoksida (CO)	8 jam	20 ppm (2260. µg/m ³)	NDIR	NDIR Analyzer	
3.	Oksida nitrogen (NO ₂)	24 jam	0,05 ppm (92,50 µg/m ³)	Saltzman	Spectrophotometer	
4.	Oksidan (O ₃)	1 jam	0,10 ppm (200. µg/m ³)	Chemiluminescent	Spectrophotometer	
5.	Debu	24 Jam	0,26 mg/m ³	Gravimetric	HI - Vol	
6.	Timah hitam (Pb)	24 jam	0,06 mg/m ³	- Gravimetric - Ekstraktf, pengakuan	- HI - Vol - AAS	
7.	Hidrogen sulfida (H ₂ S)	30 menit	0,03 ppm (42 µg/m ³)	Mercurithiocyanate	Spectrophotometer	
8.	Amoniak (NH ₃)	24 jam	2 ppm (1360 µg/m ³)	Nessler	Spectrophotometer	
9.	Hidrokarbon	3 jam	0,24 ppm (160 µg/m ³)	Flame Ionization	GC	

Note : - Measurement time is averaging time and for measurement each hour is to be done count by Geometric Mean

- Standard H₂S not valid for regions which contains natural H₂S

- *): suggested

- NDIR : Non-dispersive Infrared

- HI-Vol : High Volume Sampling Method

- AAS : Atomic Absorption Spectrophotometer

- GC : Gas Chromatograph

TABLE 7 : QUALITY STANDARD OF AIR EMISSION

NO	TYPE OF VEHICLES	TYPE OF FUEL	EMISSION AIR QUALITY			
			CO (%)	NOx (ppm)	HC (ppm)	SMOKE (%)
1.	Passenger car	- gasoline or premix	4.5	1,200	1,200	-
		- diesel fuel	-	1,200	1,200	50
		- gasoline 2 tax	4.5	1,200	1,200	50
2.	Goods vehicle	- CNG *)	3.0	-	-	-
		- gasoline or premix	4.5	1,200	1,200	-
		- diesel fuel	-	1,200	1,200	50
3.	Bus	- CNG *)	3.0	-	-	-
		- gasoline or premix	4.5	1,200	1,200	-
		- diesel fuel	-	1,200	1,200	50
4.	Motorcycle	- CNG *)	3.0	-	-	-
		- gasoline or premix	4.5	2,800	2,400	-
		- gasoline 2 tax	4.5	3,600	3,000	-

*) CNG : Compressed Natural Gas

Analyses			Methods
Distillation			ASTM D 85
10% vol.evap.	°C	72	
50% vol.evap.	°C	107	
90% vol.evap.	°C	142	
End point	°C	172	
20% - 10% evap.temp.	°C	10	
Reid Vapour Pressure at 100°C	psi	5.5	ASTM D. 323
Octane Number, F-1		86.5	ASTM D. 2699-70
Octane Number, F-2		80.7	ASTM D. 2700-70
Lead Content	g/l	0.8	ASTM D. 526
TEL Content	ml/AG	2.7	Calculated
Existent Gum	mg/100 ml	1.4	ASTM D. 381
Sulphur Content	% wt	0.007	ASTM D. 1255
Corrosion Cu-strip		ASTM No. 1	ASTM D. 130
Spec.Gravity 60/60°F		0.7424	ASTM D. 1298
API Gravity at 60°F		58.9	
Colour, Visual		yellow	
Odour		marketable	

TABLE 8 : TYPICAL TEST FIGURE OF COMMERCIAL MOTOR FUEL IN INDONESIA (PREMIUM)

Characteristics	Gas Oil (HSD) AGO	Diesel Fuel IDO
Specific Gravity 50/60 ^o F	0,820-0,855	0,850-0,920
Flash Point (P.M.CC) ^o F	154 (68 ^o C)	154 (68 ^o C)
Viscosity Kinematic at 100 ^o F	1,6 - 5,8	-
Viscosity Redwood I at 100 ^o F see S	-	35 - 45
Pour Point max. ^o F	55	55
Cloud point max. ^o F	60	-
Sediment content % wt	max. 0,01	max. 0,02
Water content % wt	max. 0,55	max. 0,25
Colour ASTM	max. 2,0	-
Ash content % wt	max. 0,01	max. 0,02
Carbon residue (Conradson) % wt	max. 0,05	max. 1,00
Sulphur content % wt	max. 0,3	max. 1,5
Copper strip corrosion	max. No. 1	-
Strong acid number mg KOH/gr	nil	nil
Total acid number mg KOH/gr	max. 0,6	-
Cetane number	min. 45	-
Recovery at 300 ^o C % vol	min. 40	-

SOURCE : PERCAMINA.

TABLE 9 : THE INDONESIAN SPECIFICATION FOR DIESEL FUELS.

SOx Jakarta Total 24,710 ton/year

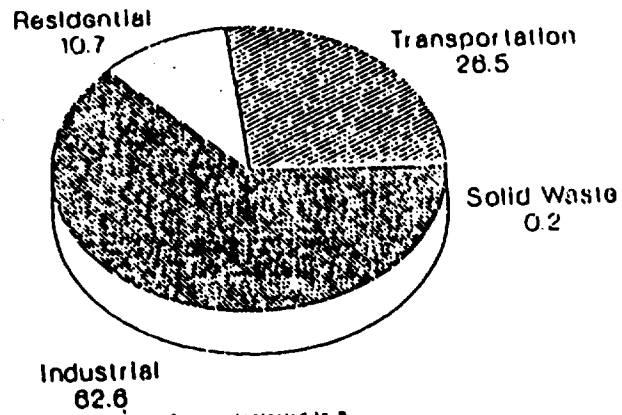

Figures indicated in %

Figure 1

Particulate Jakarta Total 7,071 ton/year

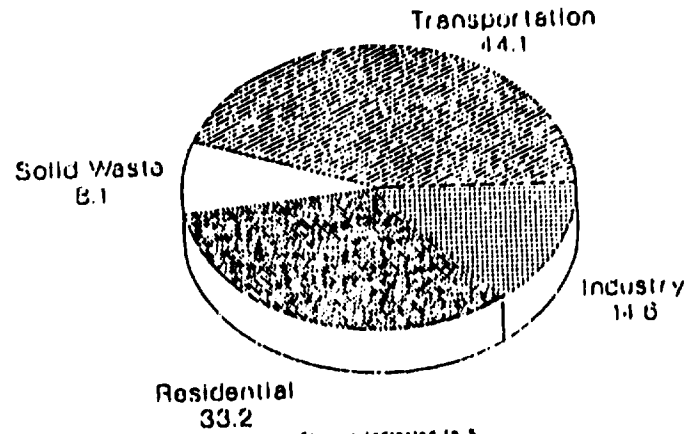

Figures indicated in %

Figure 2

NOx Jakarta
Total 20,485 ton/year

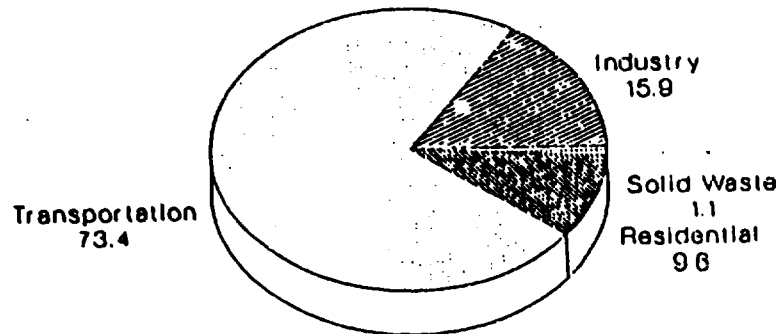

Figure indicated in %

Figure 3

CO Jakarta
Total 325,578 ton/year

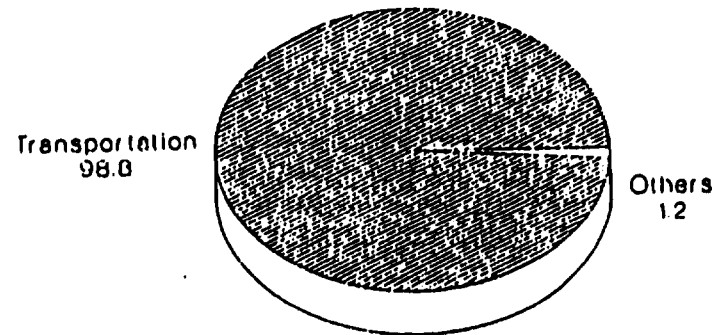
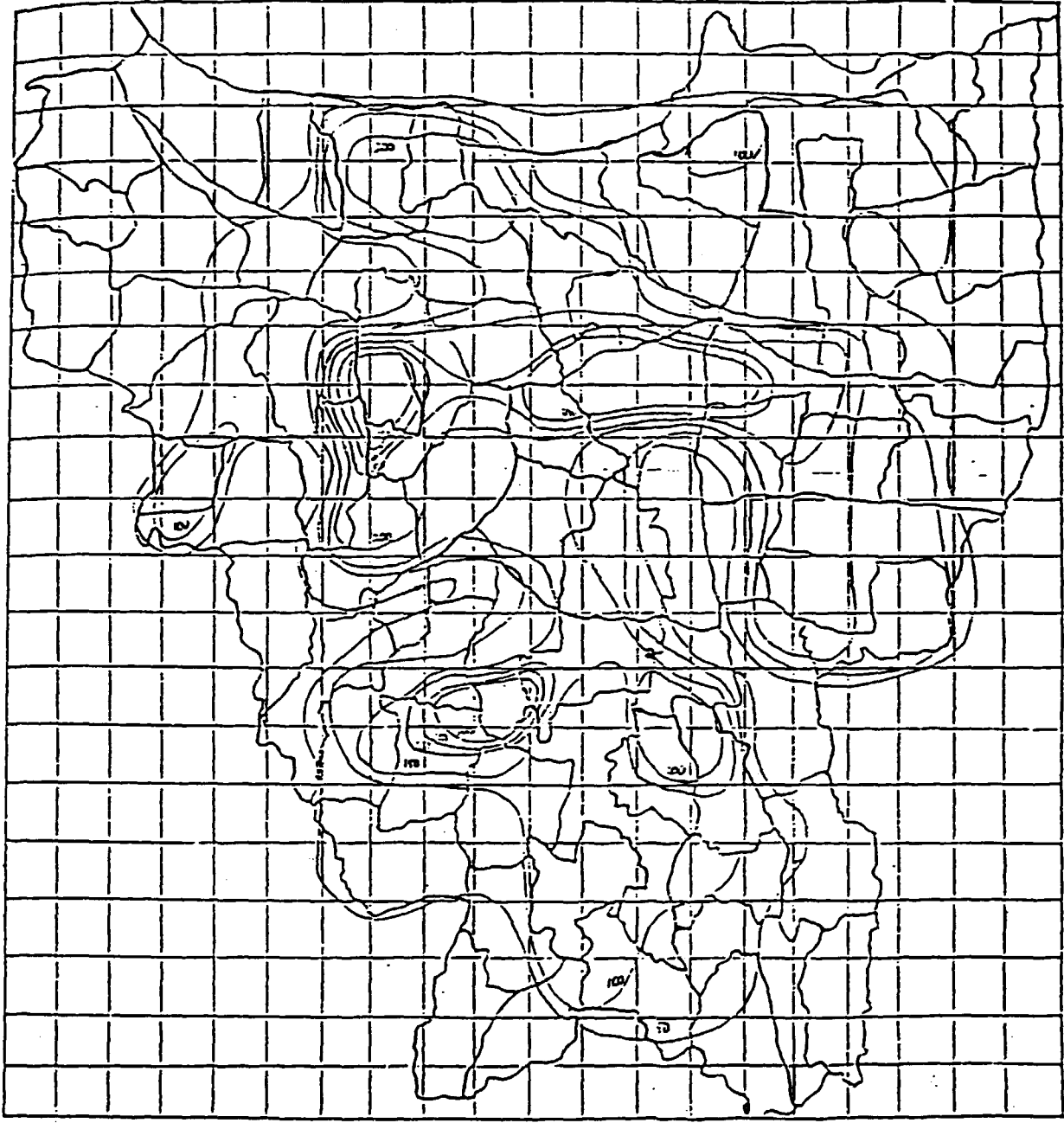

Figure indicated in %

Others = Residential, Industry, Solid Waste

Figure 4

0-1000000



ISOPLETH OF PARTICULATE POLLUTANT IN THE DKI JAKARTA ANNUAL 1989 (ug/m3)

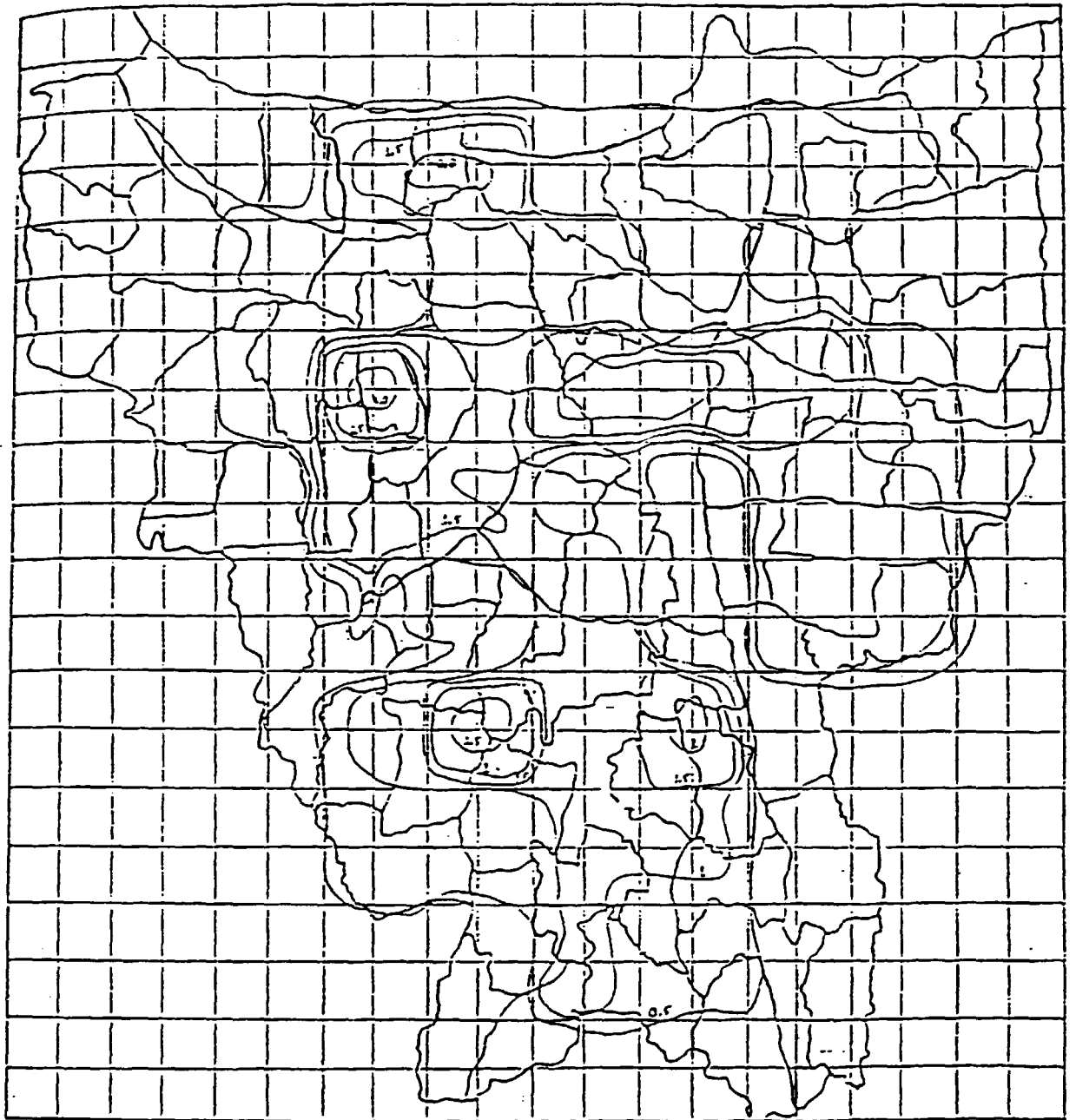

ISOPLETH OF LEAD POLLUTANT IN THE DKI JAKARTA
ANNUAL 1989 ($\mu\text{g}/\text{m}^3$)

4

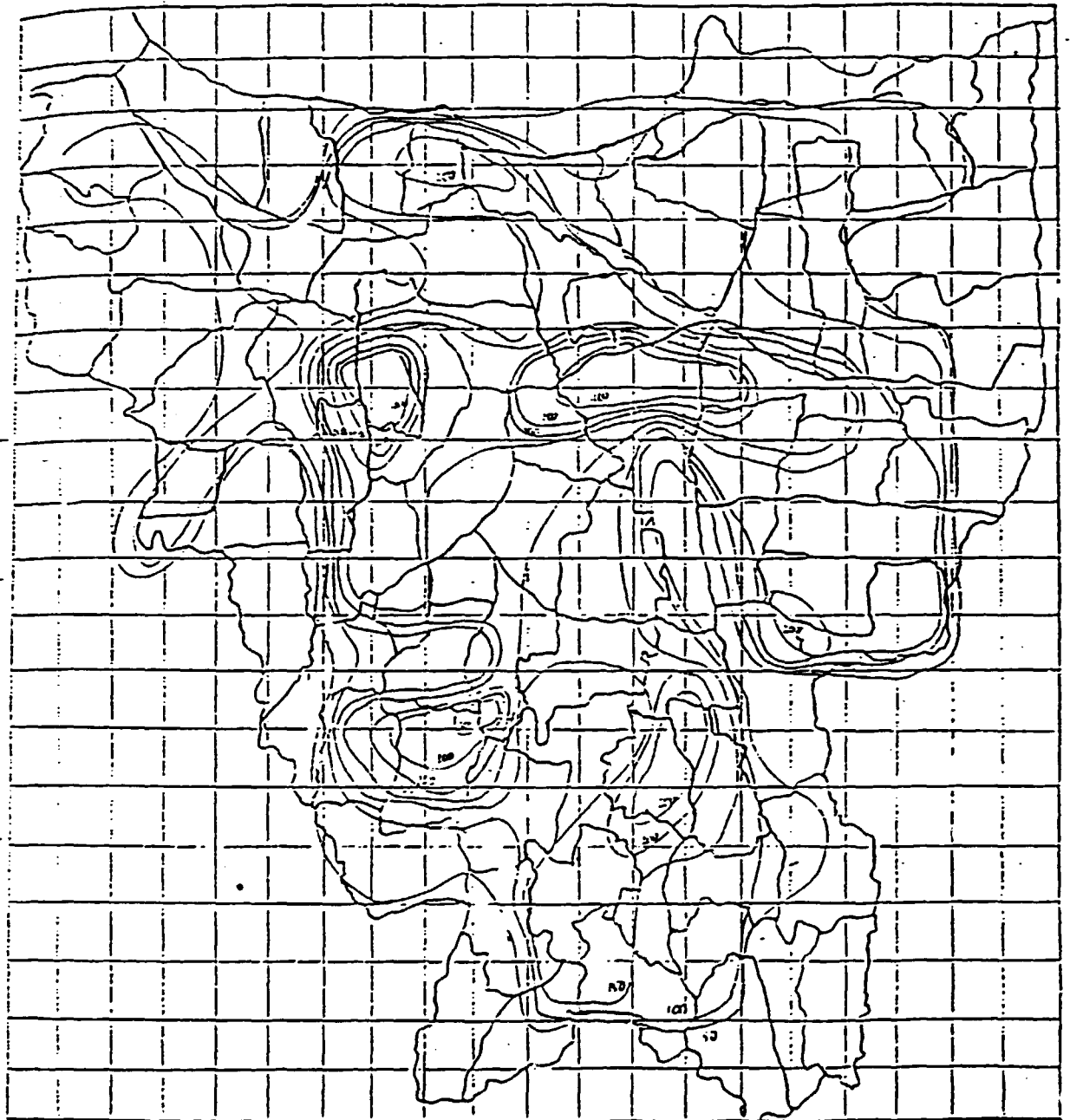

ISOPLETH OF UN-BURNED HYDROCARBON POLLUTANT IN THE DKI JAKARTA
ANNUAL 1989 (ug/m³)

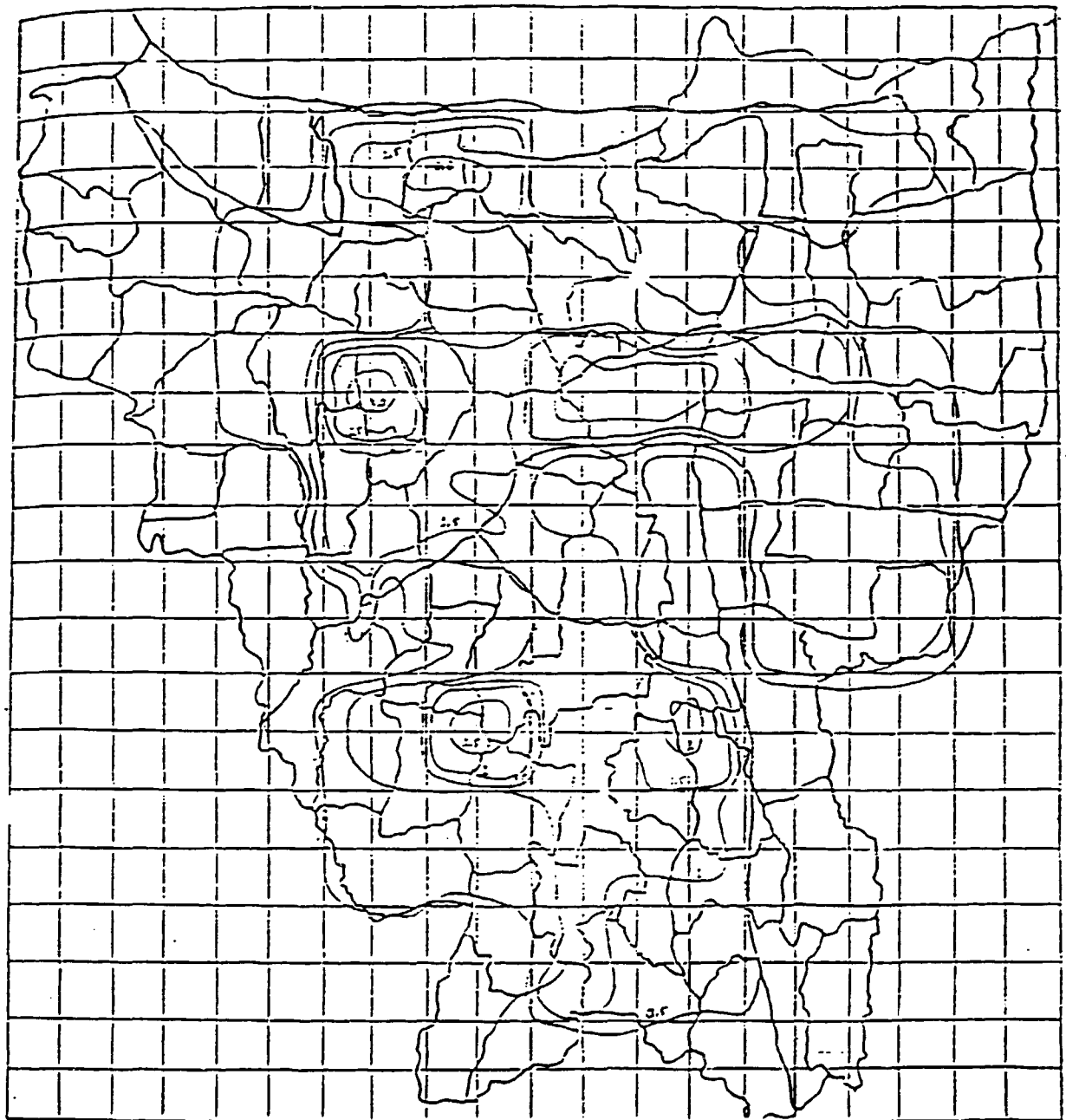

ISOPLETH OF LEAD POLLUTANT IN THE DKI JAKARTA
ANNUAL 1989 ($\mu\text{g}/\text{m}^3$)

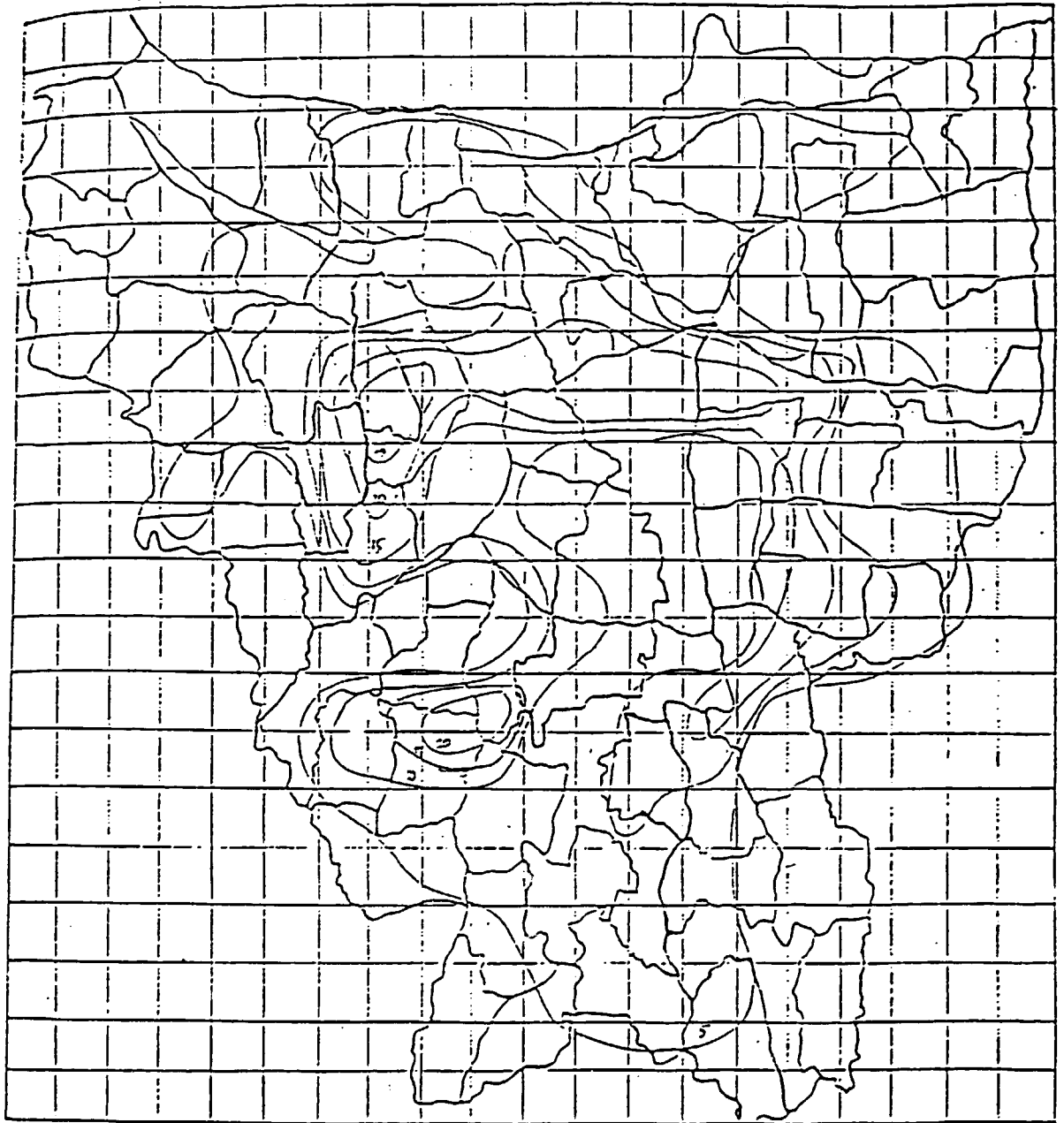

ISOPLETH OF SO₂ POLLUTANT IN THE DKI JAKARTA
ANNUAL 1989 (ug/m³)

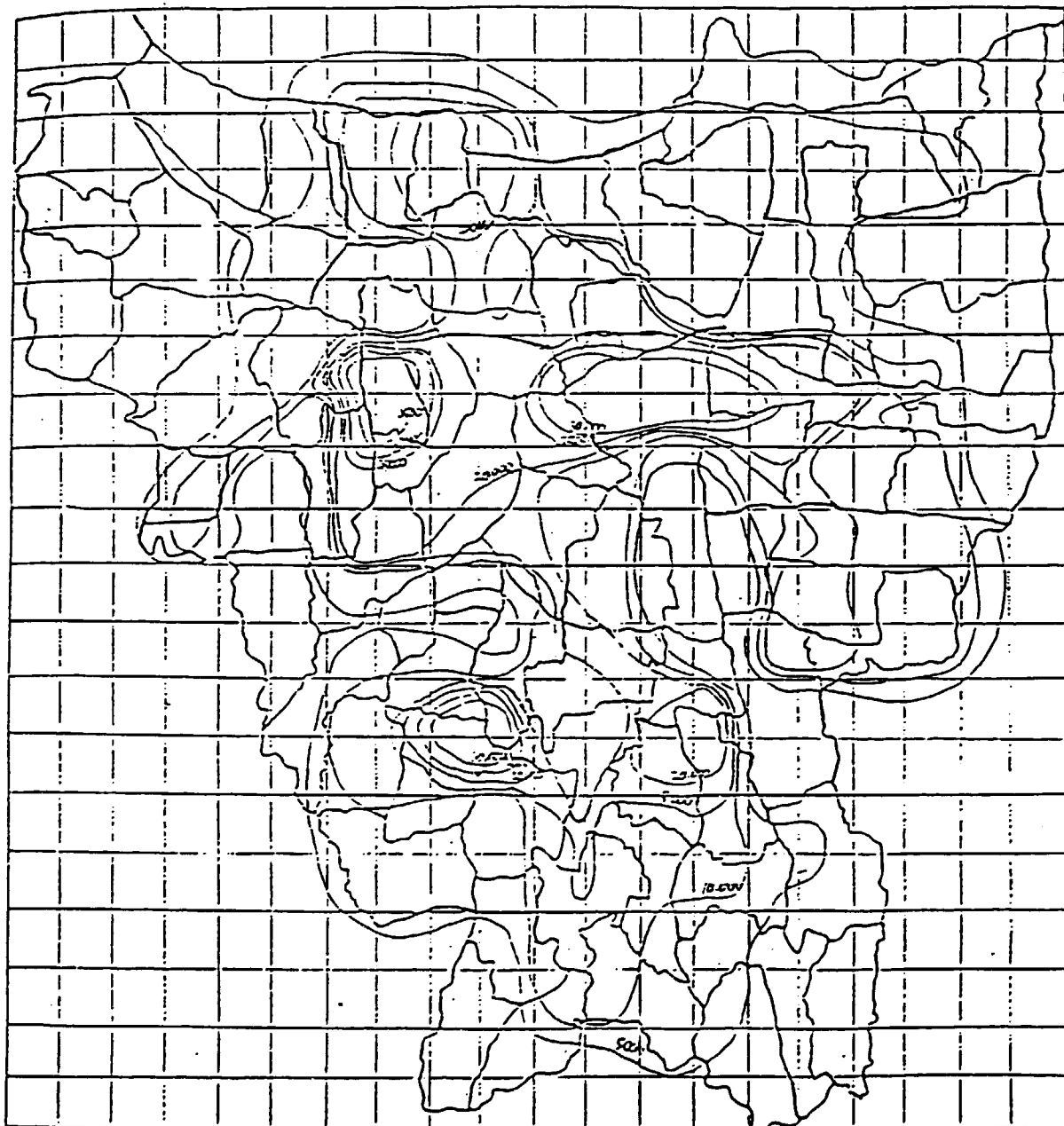

ISOPLETH OF CO POLLUTANT IN THE DKI JAKARTA
ANNUAL 1989 (ug/m3)



ISOPLETH OF NO_x POLLUTANT IN THE DKI JAKARTA
ANNUAL 1989 (ug/m³)

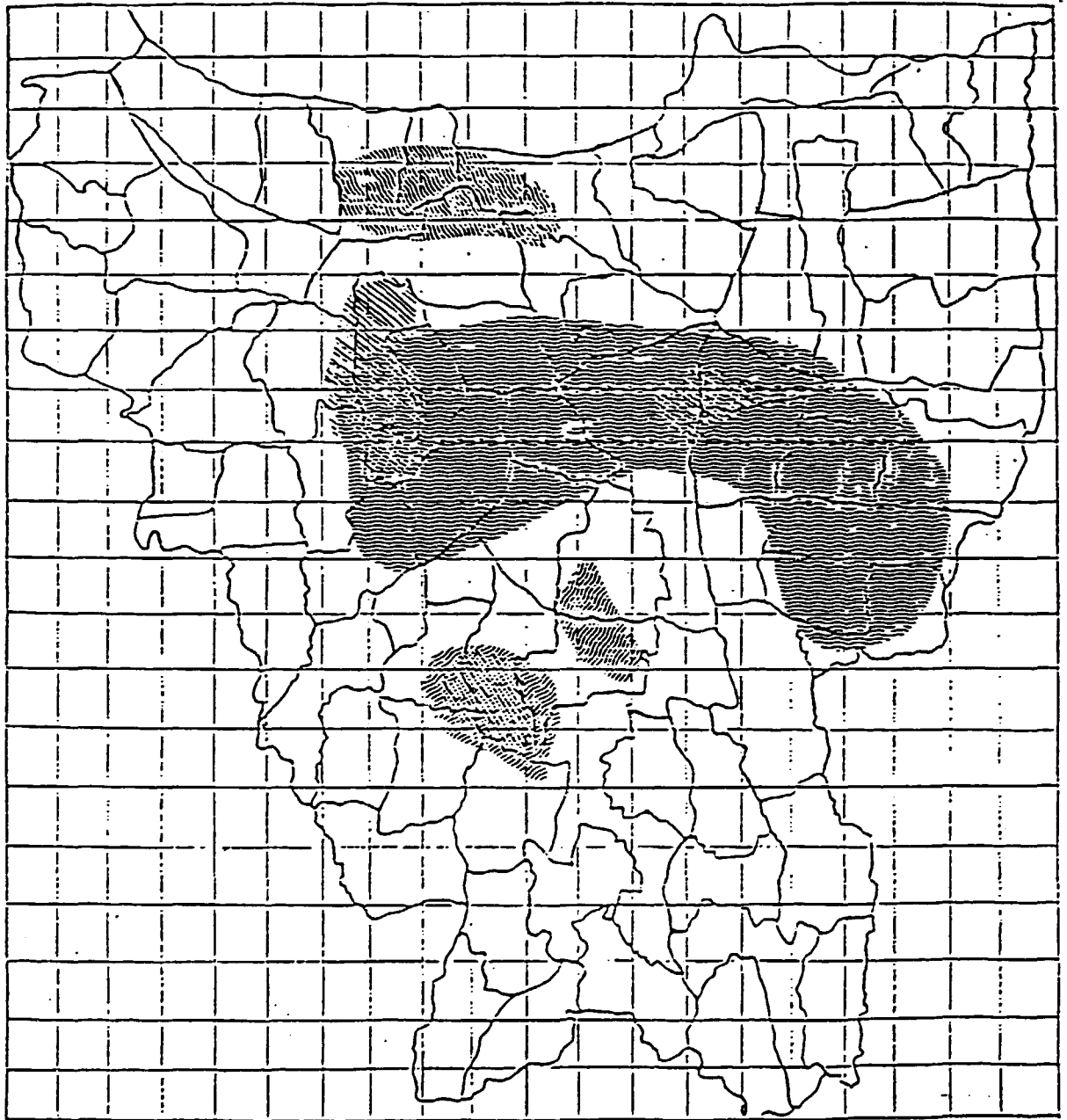





= periodically exposed high concentration than standard
(especially on January, February 1989)

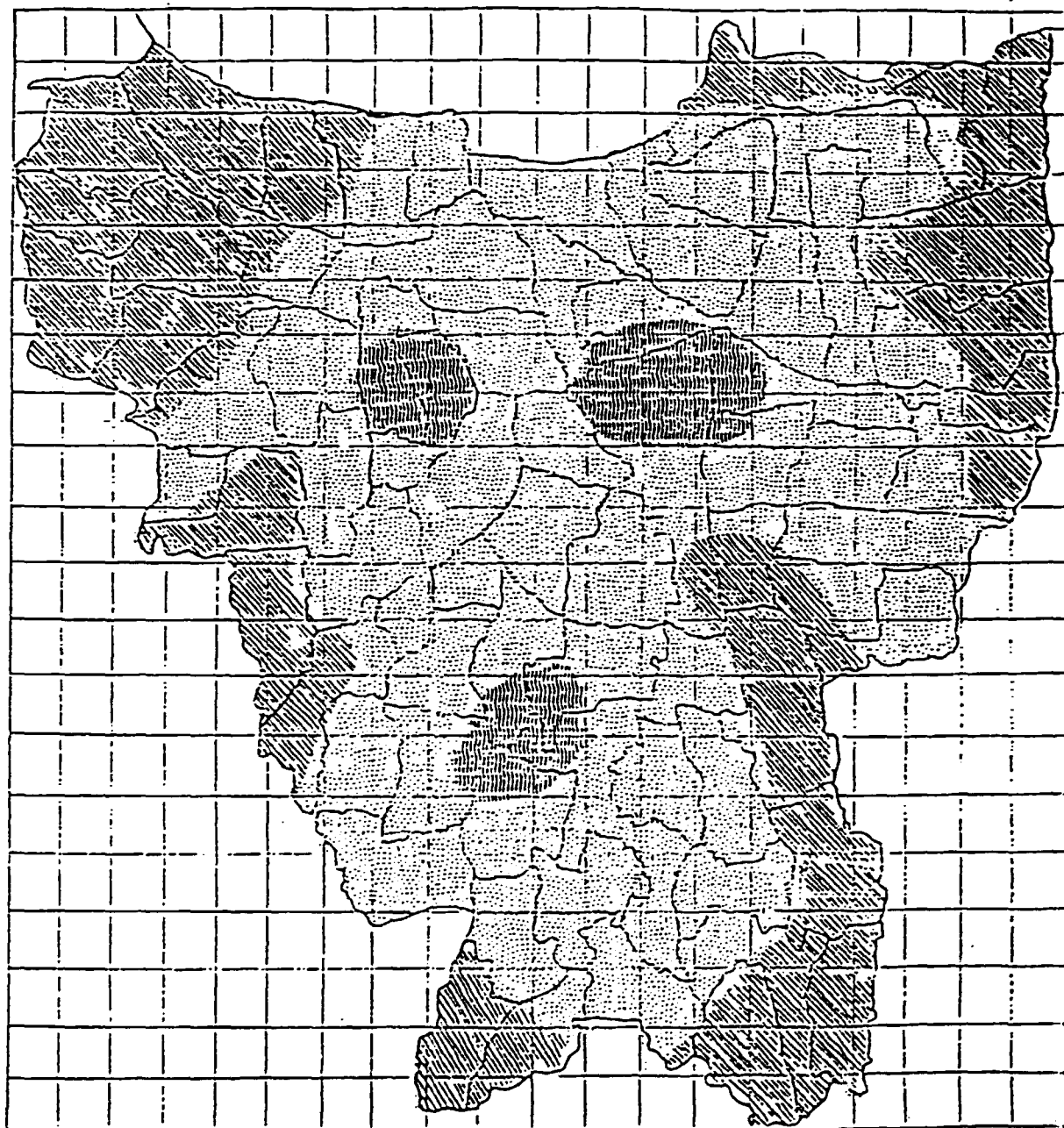

= all year exposed to high level than standard

8.16 SENSITIVES AREAS IN THE DKI JAKARTA



-  = concentration equal with concentration of background area
-  = concentration higher than air ambient standard quality
-  = concentration lower than air ambient standard quality, but concentration higher than concentration of background area

.17 DISTRIBUTION OF POLLUTANTS CONCENTRATION
IN THE DKI JAKARTA

MOTOR VEHICLE POLLUTION
IN IRAN

COUNTRY PAPER
prepared by
Mrs Paimaneh Hasteh
Teheran Traffic Control Centre

1. The Present Situation

2. Urban transport is generally believed to be responsible for between 70 to 80 percent of the emissions causing air pollution in the greater Tehran area. While automobiles are responsible for a majority of these emissions, urban buses and a large number of motorcycles also contribute to the problem. Tehran Municipality is therefore actively pursuing the development of alternate, less polluting transport modes such as a metro and trolley buses.

A. Tehran's Urban Transport System

3. It is estimated that there are about 0.75 million passenger cars and light duty trucks (< 3.5 t) in the Greater Tehran area. Around 0.5 million passenger cars, on average, are operating on any given day, each making 8.9 trips/day with an occupancy of 1.96 passengers, and the total passenger trips generated is around 8.5 million pax-trips/day. Light duty trucks number about 60,000, and make on average 5.4 trips/day with an occupancy of 1.6, generating an additional 0.5 million pax-trips/day. In total, passenger cars and light duty trucks account for about 9 million (51%) of an estimated total of about 17.5 million pax-trips generated each day in the city.

4. In addition to the above passenger cars, there are about 20,000 taxis which operate either as share taxis on a fixed route, or as regular taxis. The former charge a fixed fare per passenger (Rials 200) irrespective of distance. It was estimated (1990) that there are on average 9000 active taxis operating on a given day, with each generating 1/5 pax-trips/day, for a total of 1.6 million pax-trips/day. Passenger cars, light trucks and taxis therefore account for about 60 percent of all passenger trips in the city.

5. The number of motorcycles in the city is not known precisely; there are about 350,000 registered motorcycles, but it is estimated that the total number could be as high as 600,000. Based on an average of 7.5 trips/day and an occupancy of 1.5, it is estimated that motorcycles generate about 2.7 million pax-trips each day.

6. Buses and mini-buses account for an additional 4.2 million pax-trips per day. There are about 3500 buses and a similar number of mini-buses, though the latter are planned to be phased out as larger buses become available. Public transit services (bus and mini-bus) therefore account for less than a quarter (24%) of total passenger trips.

7. It is estimated that there about 20,000 heavy trucks in the Greater Tehran area, and about 2000 of these are government owned. About 60% of goods imported to Iran pass through Tehran for distribution to other parts of the country. Much of the truck traffic can be bypassed around the city, and heavy trucks can be kept away from the city center by using smaller trucks for urban goods delivery. Several distribution centers for goods are currently being planned for construction along the periphery of the city. For instance, one such center for fruit & vegetable distribution is being located to the south of the city.

B. Urban Transport Operations

8. Congestion Levels: At present little or no data exist on capacities or traffic volumes on various road sections in the city. However, visual observations indicate that a high level of congestion takes place during most of the day, particularly in the city center. Average vehicle speeds are said to be below 18 kmph in this Central Business District (CBD) area. There are several E-W and N-S arteries that operate at or near capacity, with the E-W corridors carrying somewhat more traffic. Bottlenecks are common at intersections which are not designed for high volume flow, and many major intersections are roundabouts.

9. Traffic Management: In order to manage the spiralling growth of traffic in Tehran, the city center was designated as a restricted traffic area about a decade ago. This area, covering about 23 sq.km. (see map attached), is the focus of current and planned traffic management schemes. Presently, about 10 percent of the vehicles in Tehran have been issued stickers which allow them to access this area during restricted hours (0630 to 1330 hrs). About two-thirds of these permitted vehicles are Government owned vehicles, another 12% are physician's cars and the remainder include taxis and other vehicles. Each permit costs between Rials 30,000 and 300,000 per year depending on the type of user. A survey conducted 5 years ago indicated that about 3.5 million daily passenger-trips were either originated or destined in this area. In addition, there is a larger area, covering about half the city, where truck restrictions apply. In this area only about 10% of the truck fleet can enter during restricted hours (0500 to 2100 hrs). No restrictions are placed on motorcycles throughout the city. Although no data exist, traffic personnel of TM believe that these restrictions have significantly reduced automotive traffic in the city center.

10. Demand Management: In order to manage peak demand on road facilities, a staggered work hours program was instituted in Tehran about two years ago.

The program called for separation of educational (school), government, and commercial start times (0700, 0800, 0900 hrs respectively), but was abandoned when found to be too rigid for most needs (eg. dropping school children off could not be combined with the work trip). Alternative programs can be pursued, particularly employer based and flexi-time programs, which have been found to be successful in many countries.

11. Parking Management: A major component of an urban transport system is parking, and this aspect appears not to have received much attention in Tehran so far. Much can be accomplished through careful controls on the amount and pricing of parking facilities. At present, most of the streets in the city center allow on-street parking, and zoning codes discourage or even prevent the construction of multi-storey off-street parking. As a result considerable road space is lost, and traffic separation/discipline is adversely affected. Any future program of traffic management should include development of a detailed parking management scheme for the city center as a high priority.

12. Bus Operations: Urban bus services in Tehran are provided by the United Bus Co. (UBC), a government subsidised public sector company. There are 3500 buses in the UBC fleet, 73% of which are 16 or more years old. All units are diesel powered (see LPG conversion below). The number of buses operating each day on the road is about 2500. The level of maintenance, as evidenced by observed emissions, of most of the buses is poor. The age, poor condition, along with overcrowding and high N-S gradients found in the city, cause the buses to emit a high level of air pollutants, mostly particulates. There are 151 bus routes with a total route length of 1800 km. Average bus speed is about 10 kmph. Total current ridership is about 3 million passengers/day which is up 32% since last year. A Park & Ride facility (2000 cars), served by express bus service, located to the east of the restricted CBD area has proved successful, and three more such facilities are planned to the north, south and west. Bus fares currently are very low, Rls 10 for regular service and Rls 50 for express service. Parking in the Park & Ride costs Rls 200. The operating cost of regular bus service has been estimated at Rls 60 per passenger trip, and therefore the tariff covers only one-sixth of costs. There are about 3500 mini-buses in Tehran. However, they are being phased out and replaced with regular buses in view of the difficult congestion situation in the city. The current public transport system is poorly integrated, and in the future it is hoped that with the development of other mass transit modes (see below) a more integrated service can be offered to effect a significant shift away from private automobile use.

C. Vehicle Technology

13. Fleet Characteristics: The major characteristic of all vehicle sub-fleets in Tehran is their high average age. The mission estimated the average age of the passenger car fleet to be 15 years, and the trend is to higher average age. According to data from the United Bus Co., the average age of the bus fleet is also high, exceeding 16 years. As regards the composition of the passenger car & light duty truck fleet, there are a limited number of vehicle types: based on domestic production data about 73% of the fleet is medium size cars (1.4 to 2.0 lt engine), mostly Paykan (1600 cc Hillman Hunter engine), and 20% small size cars, mostly Saipa/ Renault 5 (1100 cc engine). The rest being distributed among a number of other locally produced vehicles (eg. Mazda pick-ups, Land Rover, Peugeot 504, etc.). About 90% of the

motorcycles in use are of domestic manufacture, and of those larger than 50 cc, most are Honda (4-stroke) or Yamaha (2-stroke), while those less than 50 cc are all 2-stroke (eg. Vespa, Bravo, Peugeot, etc.). The bus fleet consists mainly of locally produced Iran-Mercedes Benz (UJUZ) which make up 65% of the total, and imported vehicles (Mercedes Benz, Ikarus, Volvo) make up the remainder. Three types of mini-buses (FIAT, IVECO, Mercedes Benz) are locally produced. No data exist on the composition of the heavy duty truck fleet, however, the fleet consists of a large variety of imported and locally produced trucks.

14. Engine Technology, Emission Controls and Levels: As more than 90% of Tehran's vehicle fleet consists of the above-mentioned types produced locally under license, the engine technology of the in-use fleet is mostly of European technology from the early 1960s (the Paykan produced since 1966, the Renault since 1977). This means that no emission controls at all are used, and fuel efficiency is poor (low compression, no engine modifications). Therefore it is believed that the so-called pre-ECE emission levels of the European cars are most representative of the actual emissions of the Tehran fleet. A preliminary calculation using EC COMPUTER¹ suggests the following representative emission and fuel consumption factors for the light vehicle fleet of Tehran:

CO: 63 g/km HC: 5.2 g/km NOx: 1.7 g/km Fuel Cons: 18.1 lt/100km

The above assume an average speed of 18 kmph and includes cold start and evaporative emissions (in the case of HC) and do not account for altitude and slope effects. The CO, HC, and fuel consumption figures above are particularly disturbing: a well tuned conventional engine of the 1970s could generate about 40% less CO and HC, and the fuel consumption could be on the order of 12 lt/100 km.

15. Domestic Automotive Production: In Iran there are 10 manufacturers of road vehicles, and 3 manufacturers of engines. As regards the production of light vehicles, while capacity exists to produce 150,000 vehicles per year, the actual yearly output now is about 25,000. Also, plans are underway to manufacture more modern vehicles: Peugeot 405 and 205 (Iran Khodro Co.), Renault 21 (Saipa Co.), and soon Mercedes, Citroen, Daiwo, and Volkswagen. It was noted that these vehicles are of the latest European conventional technology with regard to emission controls, i.e. they can comply with the ECE 15-04 emission standards.

16. Fuels: The mission estimated fuel consumption in Greater Tehran to be 1.5 million tonnes of normal (87 octane rating) gasoline and 250,000 t of diesel for transportation. Only a minor quantity (about 6000 kl) of super (high octane number) gasoline was consumed, which is a further indication of the poor fuel efficiency of the in-use vehicle fleet. The quality of fuels is also rather poor: 2.11 g/gal (or 0.56 g/l) lead content in the gasoline, and 1% by weight sulphur content in the diesel. Fuel volatility is also high, and the mission estimated the Reid Vapor Pressure to be 90/80 kPa. (winter/summer). A recent attempt to introduce unleaded gasoline was not

1/European Community's "Computer Program to Calculate Emissions from Road Traffic"

accepted by the public probably because the fuel had a low octane rating which caused engine knocking.

D. Air Pollution Situation

17. Overall Air Quality: According to available air quality data, the city of Tehran faces severe pollution from CO, suspended particulates, SO₂, airborne lead (7 ug/m³ yearly average) and NO₂, the levels often exceed WHO guidelines. Although no recent measurements of ozone are available, it is strongly believed that photochemical episodes occur frequently. The topography of the city (mountains to the north and east, and flat terrain to the south and west), wind direction and speed (calm most of the time with mild winds from the west/northwest), sunshine (35.4N latitude), and frequent temperature inversions (about 260 in one year, usually occurring during the night and lasting till mid-morning) provide the necessary conditions for photochemical transformation of the high VOC and NOx concentrations.

18. Emission Sources: To date no emission inventory exists for Tehran. Apart from road traffic, all of the "traditional" emission sources are to be found around the city: industries (metal and chemical factories situated mostly upwind to the west of the city, and a refinery to the south), as well as small factories located throughout the city. The city authorities, based on a theoretical approach, estimate that road traffic is responsible for 70 to 80% of the overall emissions, while the rest is attributed to industrial and residential emissions.

19. Local Pollutants: The mission, based on the assumptions laid down in Annex 11, made the following estimates of the annual road traffic emissions for Tehran (reference year 1990): CO 750 kt; VOC 90 kt; NOx 25 kt; Lead 1 kt; SO₂ 5 kt; and Particulates 0.9 kt.

20. Greenhouse Gases: Based on the fuel consumption (including industrial activities) in the urban agglomeration of Tehran in 1989, and taking into account the above estimates with regard to road traffic, the mission estimated the following emissions of CO₂:

	Consumption kt	CO ₂ Emissions kt
Gasoline	1459	3200
Diesel	2473	7800
of which transport	250	800
Kerosene	1099	3500
Heavy Fuel	984	3000

Note: No data for natural gas consumption are included.

The above indicates that road traffic accounts for approximately 23% of the CO₂ emissions, however, the total does not include natural gas which is used by nearly three quarters of Tehran households for cooking and heating. Apart from CO₂, the other greenhouse gases are also emitted in minor quantities by road traffic in Tehran, eg. CH₄ 3.7 kt, N₂O 0.1 kt.

21. Health Impacts: Studies have shown high lead concentrations in the blood of Tehran's residents. The relatively frequent occurrence of temperature inversions (as many as 260 days in a year), would indicate that

the health impacts of air pollution are significant. However, specific information on other health impacts were not available to the mission.

22. Air Pollution Monitoring: Ambient concentrations of a number of pollutants are systematically monitored by the following institutions:

- * The Department of Environment operates one (used to be 5 in 1991) station measuring CO, NOx and SO₂ ambient concentrations (until recently THC and suspended particulates were also measured).
- * Ministry of Health operates 13 stations, monitoring SO₂, suspended particulates and lead.
- * Ministry of Oil operates 2 stations (one mobile), monitoring SO₂, NO₂, particulates, sulfation rates, haze, and meteorological data.
- * The Atomic Energy Organisation of Iran measures trace elements (eg. lead, etc.).

E. Policies Affecting Urban Transport

23. Fuel Pricing: Fuel prices in Iran have historically been set at extremely low levels. Presently, gasoline is priced at Rls. 50 /litre (US\$ 0.14 /gallon), and diesel at Rls. 10 /litre (US\$ 0.03 /gallon). These low-fuel prices have several implications for urban transport and air pollution in Tehran. Automobile use is favored over public transit, since the latter cannot compete at such extremely low fuel prices. Further, fuel efficiency is not an important consideration, and the continued use of extremely inefficient and obsolete vehicles (about 40% of Tehran's automobile fleet can no longer be tuned-up) is the major cause of high vehicle emission factors, and the consequent high contribution of urban transport to air pollution in Tehran. Introduction of unleaded gasoline has also been hindered by the low prices which make the cost of producing such fuels uneconomic.

24. Provision of Public Transit: Public policy has long favored automobile ownership over the provision of public transport. In fact, previous governments had made the ownership of one automobile per family an objective of public policy. As a result, development of public transport services in Tehran was not, until recently, accorded much priority, and even today public bus services are generally regarded as a socially inferior form of transport. Bus tariffs have accordingly, and in line with the low cost of automobile use, been kept extremely low (Rls. 10 /trip) with the result that the public bus company recovers about one-sixth of costs, and on some routes only minimal services are provided. The Municipality is now actively pursuing a number of public transport initiatives such as express buses from Park & Ride locations, the Metro and Trolley Bus (see below), however the success of these efforts will depend to a large extent on either rectifying the distortions caused by low fuel prices, or reliance on heavy subsidies for public transport.

25. Land Use Policies: Tehran has grown rapidly from a city of less than one million people in 1946, 4.5 million in 1976, to over 6 million in 1986. The resident population now is estimated to be about 7.2 million, and including the people who come into the city during the day, the population

served by the urban transport system is estimated to approach 10 million. This rapid growth in demand has led the city to increase zoning densities in the downtown areas, with densities being tripled in some cases. These increases in densities have not been coupled with increased provision of competitive public transport facilities, and even though the city is adequately endowed with road space (24% of land area), the resulting increase in vehicular traffic has caused severe congestion in the downtown area. Agglomeration diseconomies may already have set in: there now appears to be a net out-migration from the city, with the urban growth rate, which was over 4 % pa. recently, declining to 1.8 %, which is below the rate of natural increase for the nation.