



TOGETHER
for a sustainable future

OCCASION

This publication has been made available to the public on the occasion of the 50th anniversary of the United Nations Industrial Development Organisation.



TOGETHER
for a sustainable future

DISCLAIMER

This document has been produced without formal United Nations editing. The designations employed and the presentation of the material in this document do not imply the expression of any opinion whatsoever on the part of the Secretariat of the United Nations Industrial Development Organization (UNIDO) concerning the legal status of any country, territory, city or area or of its authorities, or concerning the delimitation of its frontiers or boundaries, or its economic system or degree of development. Designations such as “developed”, “industrialized” and “developing” are intended for statistical convenience and do not necessarily express a judgment about the stage reached by a particular country or area in the development process. Mention of firm names or commercial products does not constitute an endorsement by UNIDO.

FAIR USE POLICY

Any part of this publication may be quoted and referenced for educational and research purposes without additional permission from UNIDO. However, those who make use of quoting and referencing this publication are requested to follow the Fair Use Policy of giving due credit to UNIDO.

CONTACT

Please contact publications@unido.org for further information concerning UNIDO publications.

For more information about UNIDO, please visit us at www.unido.org

RESTRICTED

21057

DP/ID/SER.A/1723
13 April 1995
ORIGINAL: ENGLISH

ASSISTANCE IN THE ESTABLISHMENT
OF A PILOT FURNITURE PLANT

DP/DRK/86/011

THE DEMOCRATIC PEOPLE'S REPUBLIC OF KOREA

Technical report: Training manual on veneer trimming and joining

Prepared for the Government of the Democratic People's Republic of Korea
by the United Nations Industrial Development Organization,
acting as executing agency for the United Nations Development Programme

Based on the work of Radmilo Malis,
expert in furniture production

Backstopping officer: Antoine V. Bassili,
Agro-based Industries Branch

United Nations Industrial Development Organization
Vienna

* This document has not been edited

V.95-53019

TABLE OF CONTENTS

	Page
PREFACE	iii
1. Introduction	1
2. Utilization of veneer and veneer cutting list	4
3. Veneer clippers	5
4. Veneer trimming tools	6
5. Operating instructions for veneer clipper	6
6. Safety measures for veneer trimming operations	7
7. Veneer joining machines	12
8. Thermoplastic thread for joining veneer	13
9. Organization of work area	14
10. Operating instructions for veneer joining machine	14
11. Safety measures for veneer joining operation	15
12. Veneer controlling table	15
13. Inspection of veneer sheets and repairing defects	15
Figures	
1. Pyramid figure used when the grain direction of the veneer is vertical	1
2. Straight and narrow stripped veneer used when the grain direction of veneer is horizontal	2
3. The symmetry of figures is achieved by opening packs of veneer like a book	2 3
4. Veneer cutting list	3
5. Veneer trimming with double cut	5
6. Knife for the veneer trimming machine model NG-28	8
7. Principles of joining veneer with paper tapes	8
8. Principles of joining veneer with a thermoplastic thread	9
9. Zigzag veneer joining machine	10
10. Governing and controlling panel for veneer joining machine	11
11. Working head of the veneer joining machine	12
12. Thermoplastic thread pressing roller	13
13. Organization of the work area	13
Annex I	16
Annex II	20

PREFACE

This training manual is one of a series prepared by a UNIDO Furniture Production Expert, Radmilo Malis, while serving as Chief Technical Adviser of a UNDP financed and UNIDO executed project in the People's Democratic Republic of Korea, to assist in the establishment of a Pilot Furniture Plant in Pyongyang (Project DP/DRK/86/011).

This manual deals with veneer trimming and joining.

These manuals were written to achieve two major goals, first: to give trainees a broader view of an industrial system and second: to serve as a practical guide to machine operators and assemblers, thus enabling them to better perform their duties.

A particular attention has been devoted to materials and their correct utilization, to the design and quality of products, to the organization of the work areas and to safety measures.

The description of the machines is based on those bought for the Pilot Furniture Plant.

These manuals have been written in such a way that they can also apply to other similar factories and to vocational training institutions.

The entire scope of the training envisaged to be given, with the intended audience for each topic is given in Annex I.

The syllabus, namely the topics, the duration of lectures (theory) and practical work and the level of competence attained after completion of the course on this topic is given in Annex II.

1. Introduction

The surface of low grade wood products (particle board, plywood, fibreboard, etc.) are decorated with slices of decorative timber of thicknesses ranging between 0.5 and 1 mm. Veneer trimming and joining operations deal with the preparation of veneer sheets which are used for the surfacing of the panels.

2. Utilization of veneer and veneer cutting list

Wood having the required quality to serve as a raw material for decorative veneer is becoming scarce and expensive. With the trend towards natural rather than artificial panel surfaces, the demand for decorative veneer is bigger and prices are continuously rising. This situation creates pressures on the industry to obtain a high recovery on raw material as well as a higher yield of the final product. Surface veneers usually have a thickness of 0.5 to 1 mm and the veneer used on edges are 1 to 2 mm thick.

Broadleaved species such as oak, ash, elm, birch, etc. are usually used to produce decorative veneers. Ring porous hardwoods have specially attractive decorative grain figures. Coniferous trees such as pine, spruce and larch are also used for producing decorative veneers. Radially and tangentially sliced veneers can be distinguished from their grain figures, because of different patterns. In radially sliced veneer, the annual rings are straight lengthwise lines, whereas tangentially sliced veneer has conical figures. The composition of veneer sheets for veneering well exposed furniture parts must be harmonious with respect to the species, the grain structure and colour shade. When furniture elements of a modular system are produced, a uniform aspect of the veneer is even more important.

A pyramid figure is usually allowed to some extent for parts in which the grain direction of the veneer will be vertical, eg. case furniture, doors and sides (see fig. 1). Parts in which the grain direction will be horizontal require straight and narrow striped veneer, eg. tops and drawer faces of case furniture (see fig. 2). This is decided upon when designing the furniture.

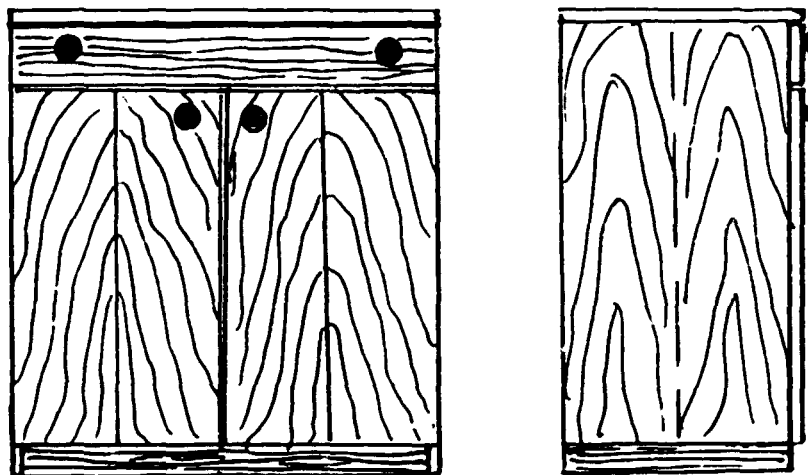

Fig. 1: Pyramid figure used when the grain direction of the veneer is vertical

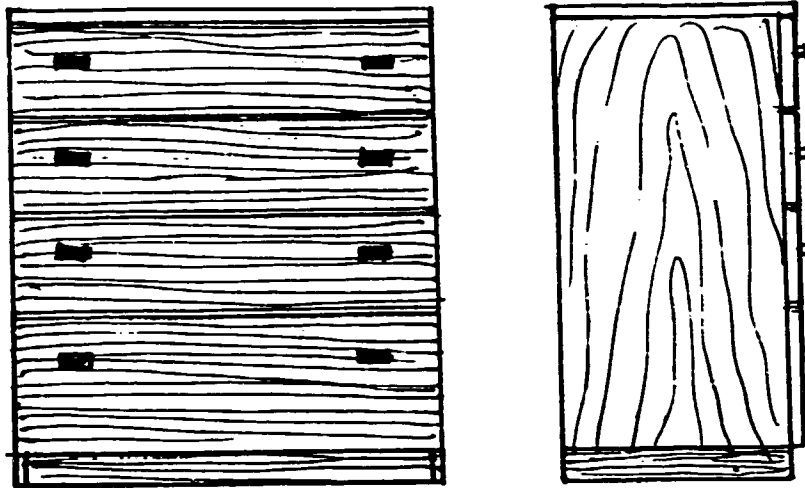

Fig. 2: Straight and narrow stripped veneer used when the grain direction of veneer is horizontal

In order to ensure having an harmonious composition of veneer sheets, they are packed in the order of slicing. The symmetry of the figures is achieved by opening the packs like a book (see fig. 3). Apart from the wood species, grain structure and size of veneer, the colour shade is a very important property of decorative veneer. It depends on the species of wood, the part of tree it is contained from (sapwood or heartwood) and sometimes the discolourations caused by fungal attacks.

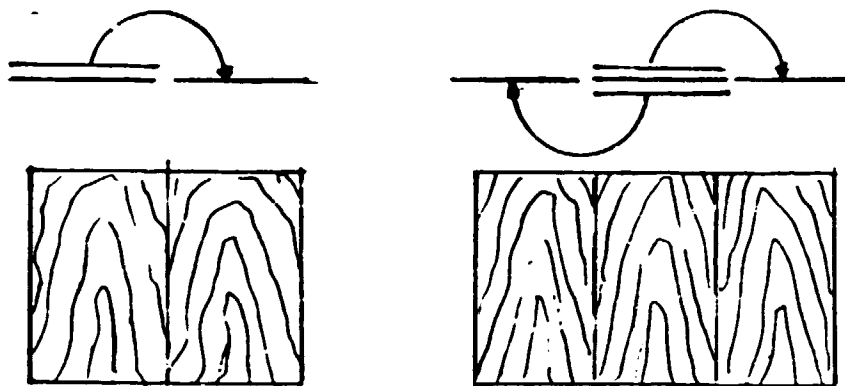

Fig. 3: The symmetry of figures is achieved by opening packs of veneer like a book.

3. Veneer clippers

Veneer clippers resemble a guillotine. These are used for crosswise and lengthwise cutting of veneer packs in order to obtain the required dimensions. Straight and smooth long edges suitable for splicing veneer sheets are also obtained. There are various constructions of veneer trimming machines, but the basic working principles are similar.

In the case of the Pilot Furniture Plant, a veneer pack clipper, model NG 28 (produced in the USSR) is installed. It is foreseen to be used for crosswise and lengthwise cutting of veneer packs. The technical data of this machine are as follows:

- Maximum length of the veneer pack 2800 mm
- Width of veneer pack min. 75 mm, max. 1000 mm
- Maximum thickness of veneer pack for lengthwise cutting 90 mm; for crosswise cutting, 30 mm
- Duration of the knife's cycle 2.5 sec.
- Pressure on the surface of the pressure beam: 0.2 MPa
- Length of knife 3000 mm
- Power of electric motor: main motor 7.5 kW, feeding motor 0.55 kW.
- Capacity of hydraulic pump 100 (l/min)
- Maximum hydraulic pressure 6.3 MPa

The machine is equipped with a steering and push button control system with measuring instruments, feeding system, cutting system, electrical system, hydraulic system and safety system.

The feeding system consists of a feeding device designed to bring the veneer pack to the knife. It is foreseen for plywood production and cannot be used for trimming decorative veneer.

The cutting system consists of a knife, a knife support, a pressure beam, a working table, a counter-knife, a wooden insert and a light beam showing the cutting line. The pressure on the veneer pack must be equal on its whole length. The electric system consists of electrical motors, magnets, relays, etc. The hydraulic system consists of a pump and cylinders which produce the driving force for the knife support and for the pressing beam.

The safety system consists of two push buttons for cutting (both hands must be used in order to cut); photo relay beams which block the machine if anything is approaching the cutting line. The machine is grounded to prevent electric shock.

Trimming is done by double moving and double cutting. The purpose of the second cut is to remove broken edges thus achieving flat veneer edges suitable for gluing (see fig. 5).

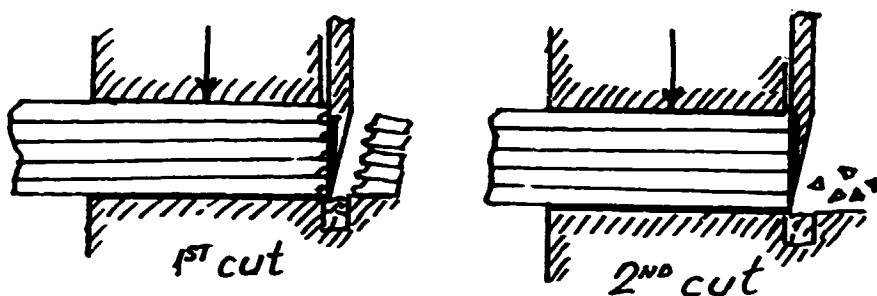

Fig. 5: Veneer trimming with double cut.

4. Veneer trimming tools

A knife having the correct size is used for veneer trimming. The length of the knife depends on the size of the veneer clipper and this is usually between 600 and 2000 mm. Its width ranges usually from 100 to 150 mm, and its thickness from 8 to 15 mm. The sharpening angle α is 20 to 30°. The knife is made of high speed steel with a hardness between 56 and 62 Rc. The knife is sharpened regularly by wet grinding on a knife grinding machine. After grinding, the knife is fixed on a support with bolts and nuts. The nuts must be tightened from the middle alternately towards both ends of the knife.

To avoid veneer tearing, a counter-knife is mounted on the working table, parallel to the knife, with a small space between both. The edge of the counter-knife must also be sharp and straight. The dimension of the knife of the NG-28 veneer clipper with its elements is shown in Fig. 6 hereunder.

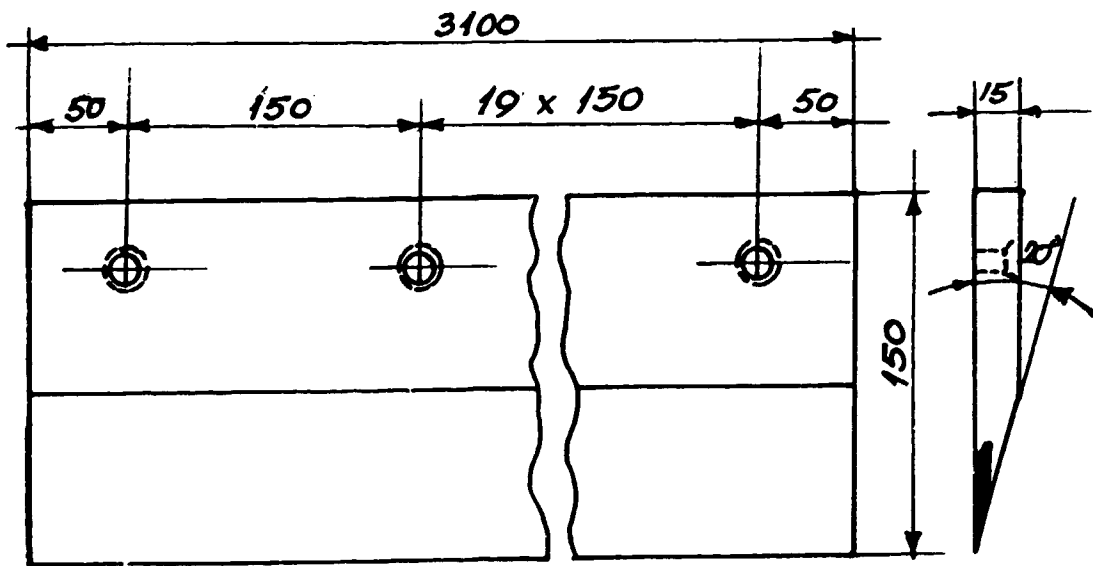

Fig. 6: Knife for the veneer trimming machine model NG-28.

5. Operating instructions for the veneer clipper

The knife should be set in the lower end position. It must be set for cutting with its complete length and with a maximum 1.5 mm notch into the wooden insert. When setting or removing the knife, the main switch on the machine must be turned off. The hydraulic pressure must be set at 5.5 MPa (55 kgs/cm²) as indicated on the manometer. Setting the pressure relay should be done when the pressure beam is released and the pressure relay is set at 5.5 MPa.

The machine must be checked when operating and, if necessary, adjusted for proper veneer trimming. The knife must be removed from the machine for sharpening. First, the support for fixing the roller is moved by turning a bolt two full rotations. After release of the support, the clearance between the roller and the support should be 2 mm. To remove the knife from the machine, the following sequence must be adhered to:

- When the knife support is in the upper position, four bolts should be unscrewed and taken out on the right side of the knife;
- the knife support is moved down to the lower position and three bolts are unscrewed and taken out on the left side of the knife.
- The support should then be lifted to the upper position.
- On the left side of the working table, a piece of wood (70x90x180mm) is inserted to prevent the support from falling.
- The knife support is released until the knife is positioned on a special fixture.
- When the remaining bolts are taken out, the knife falls into a fixture and can be removed from the machine;
- The knife is set by following the opposite sequence.

The veneer clipper is used to cut veneer packs and to produce veneer sheets with straight and smooth edges. For a straight cut, the pack is pressed down with the pressing beam. The pack of veneer is placed manually on the working table. The edge to be cut should be positioned under the cutting line which is marked with a light beam. The light beam helps minimize waste and is an orientation for cutting at the desired position.

After pressing the pack, two push-buttons must be pressed simultaneously to cut, using both hands. After each double cut, the knife support will stop in the upper position. After a cut, the pressing beam is released. For more comfortable work, one can switch to the manual governing of the pressing beam. After the second cut, the waste must always be removed from the machine.

To be remembered: Before work starts, the buttons that lift the pressing beam and knife support, to bring them into the upper position, must be pushed. If a cut is not satisfactory, the sharpness of the knife, its setting, or the hydraulic pressure on the manometer must be checked.

6. Safety measures for veneer trimming operations

Apart from general safety measures, the operator of the veneer clipper must pay attention to the following:

- Only one person is allowed to work on the machine at any point in time. The machine is constructed so that both hands must be used to press the buttons for cutting, so that the operator's hands are protected.
- The working table must always be clean. After every double cut, the waste must be removed into a container.
- A damaged wooden insert on the working table must be replaced in time and properly fixed with screws. This insert must be very precise.
- The knife must always be stopped at the position in which it is covered by the pack pressing beam.

7. Veneer joining machine

There are basically three different types of veneer splicers:

- A veneer splicer joining veneer edges with paper tapes (see fig. 7).
- A veneer splicer joining veneer by gluing thermoplastic thread (see fig. 8), and
- A veneer splicer joining veneer edges by glue spreading on the edges.

The disadvantage of the splicer working with the gluing paper is that a tape must be placed on the face of the veneer and removed after veneering prior to sanding. The zigzag veneer joining machine uses thermoplastic gluing thread for joining veneer edges. The thread is placed on the reverse side of the veneer and must not be removed. Splicing veneer by glue spread over the edges immediately after trimming is common in plywood production. The newest development is similar machines for splicing decorative veneer. These machines are very productive and expensive, but the expensive thermoplastic thread is replaced by cheaper glue. In the case of the Pilot Furniture Plant, a zigzag joining machine with thermoplastic glue is used. The basic working principle of the machine is that synthetic thread passes through a pipe heated by an electric heater and is pressed in a zigzag pattern along the edges of the veneer to be joined. The pace of the zigzag line can be altered by changing the feeding and swinging speed of the thread guiding element.

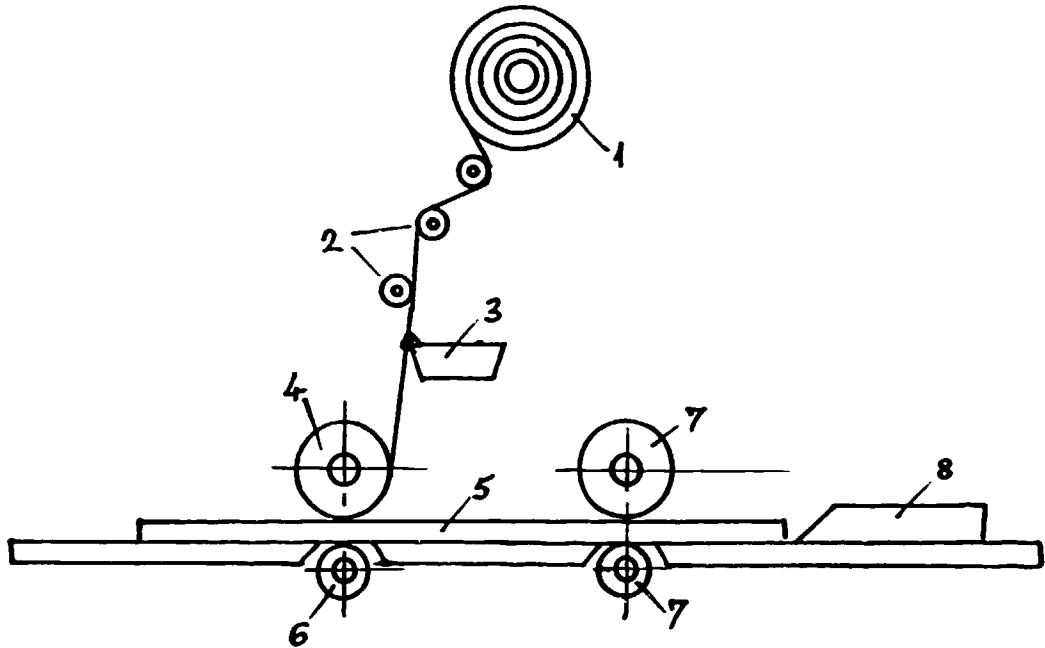

Fig. 7: Principles of joining veneer with paper tapes:
(1) paper tape roll, (2) tape guiding rollers, (3) dish for tape moistening
(4) roller giving tape to veneer, (5) veneer
(6) conical rollers bringing the veneer edges together,
(7) feeding rollers, and (8) guide.

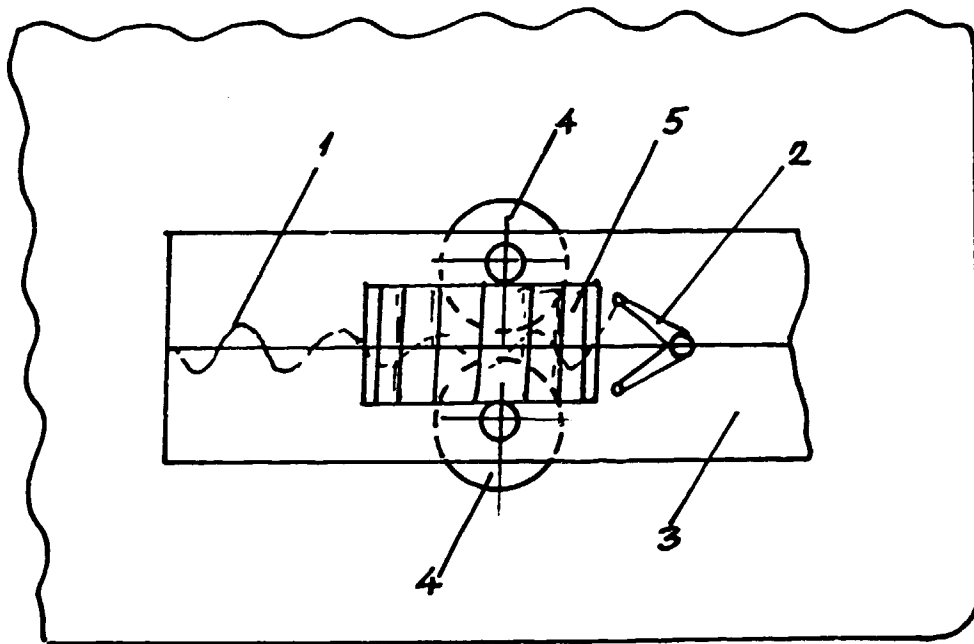

Fig. 8: Principles of joining veneer with a thermoplastic thread:
(1) thermoplastic thread, (2) guide of the thread, (3) veneer
(4) disc used to press veneer edges, (5) upper roller pressing
the thread on the veneer surface.

The feeding speed ranges between 14 and 35 m/min. The largest width for a veneer sheet is 1100 mm. Figs. 9, 10, 11, and 12 show the main parts of the zigzag veneer joining machine which is installed in the Pilot Furniture Plant.

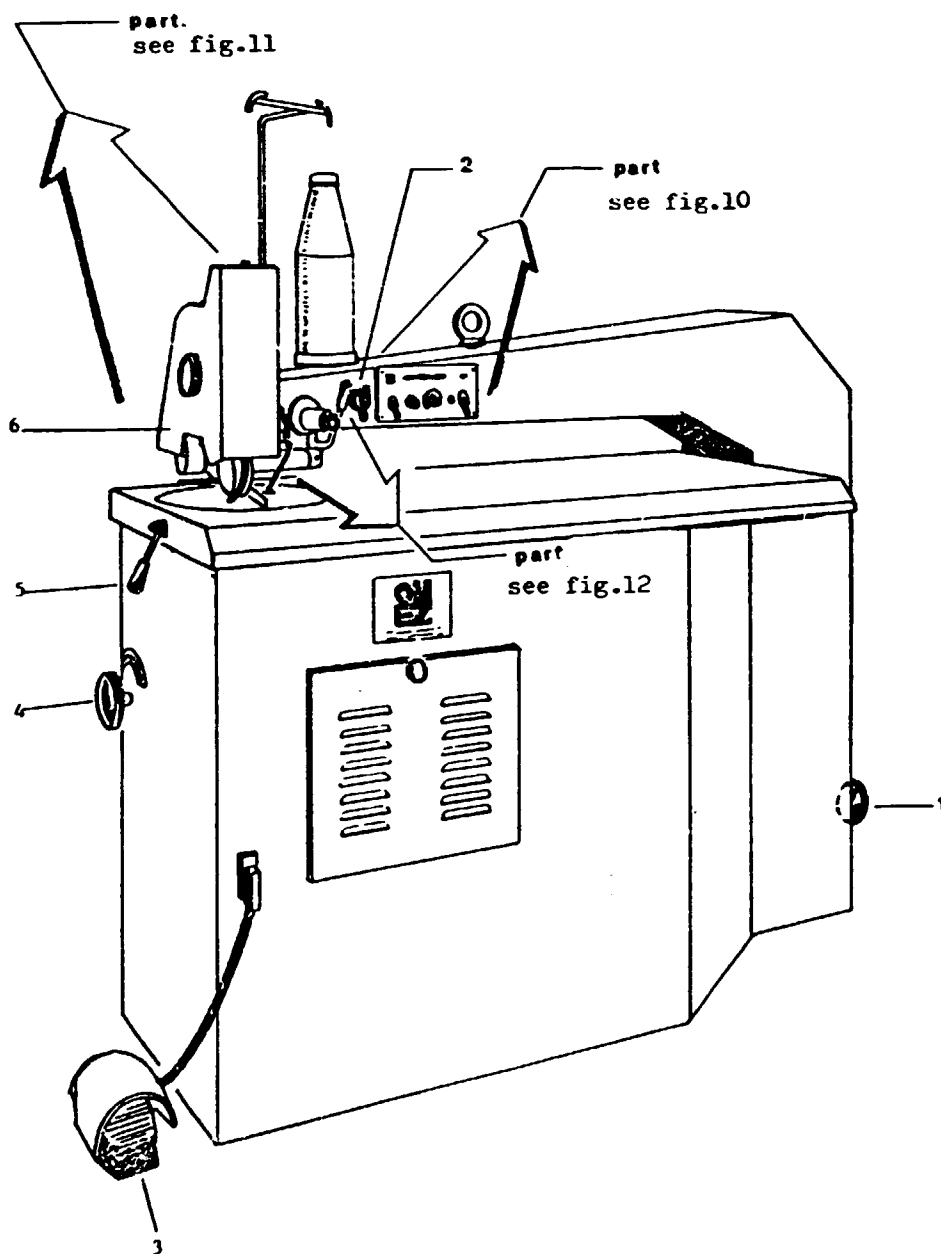

Fig. 9: Zigzag veneer joining machine:
(1) main switch box, (2) general switch, (3) emergency pedal to block machine,
(4) Fly-wheel speed governor, (5) lever for closing veneering drive,
(6) gear case for covering the head.

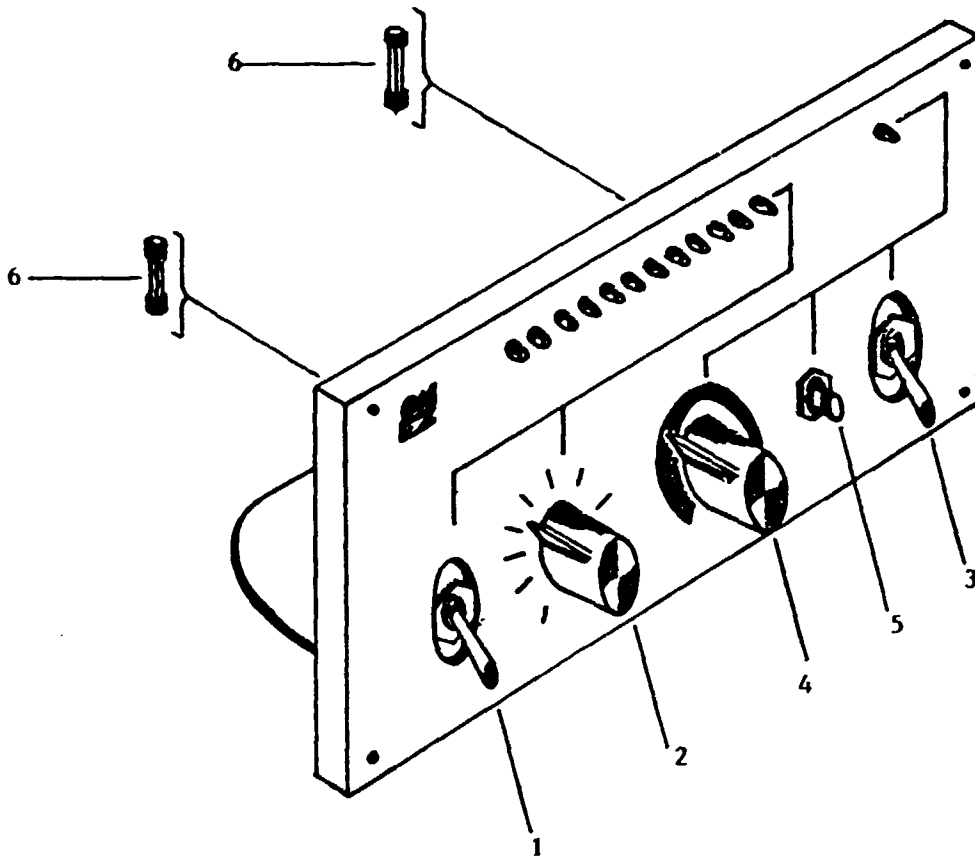

Fig. 10: Governing and controlling panel for veneer joining machine:
(1) switch for resistance ignition, (2) knob for setting the resistance temperature, (3) switch for ignition motor, (4) timber for piece's ejection, (5) manual ejector of the end piece, and (6) protection fuses.

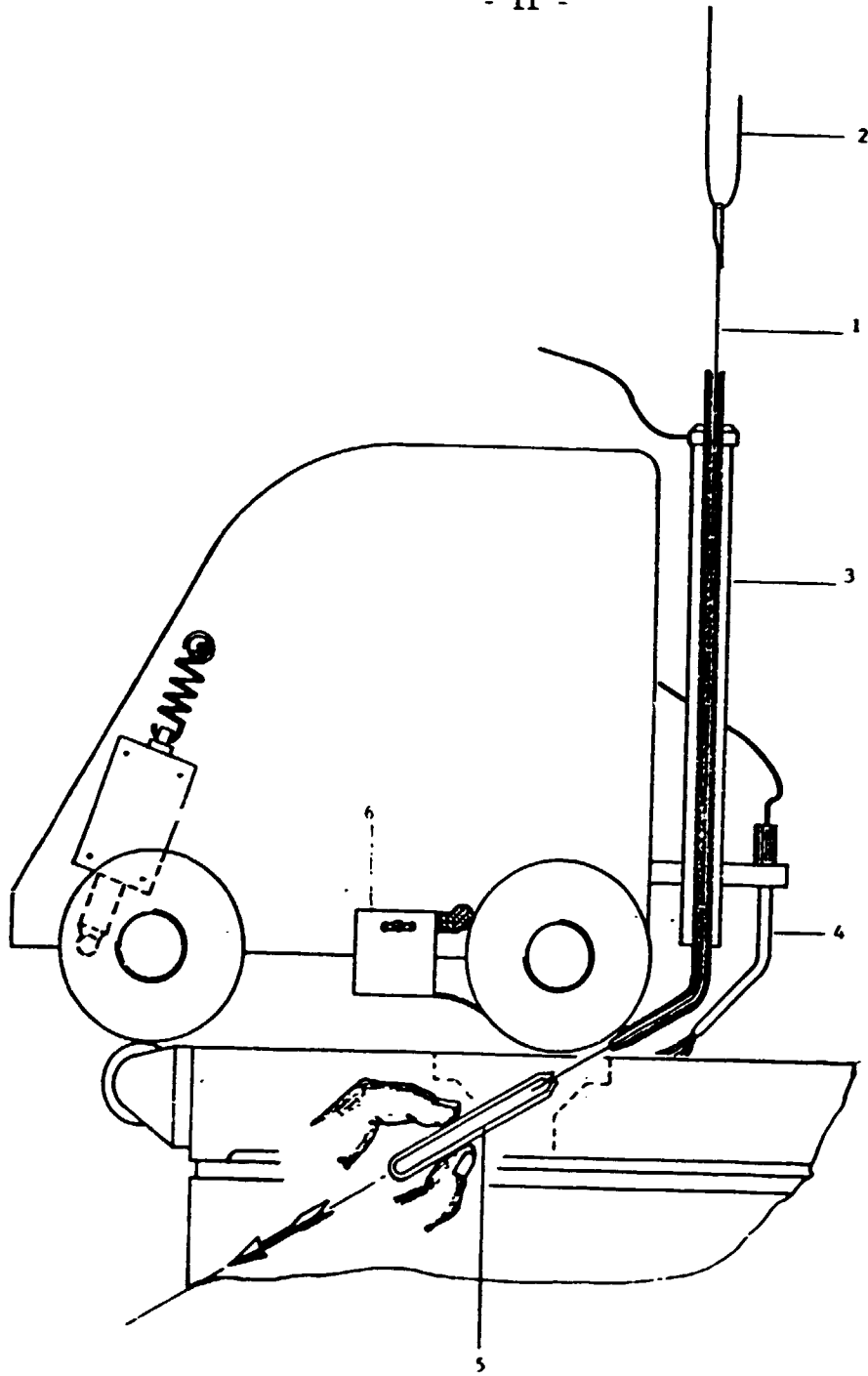

Fig. 11: Working head of the veneer joining machine:
(1) thermoplastic thread, (2) needle, (3) warming resistance
for thermoplastic wire, (4) small contact brush, (5) pliers for drawing
out the needle and thermoplastic wire, and (6) tank with a sponge for
separating gluing - SINT-P2.

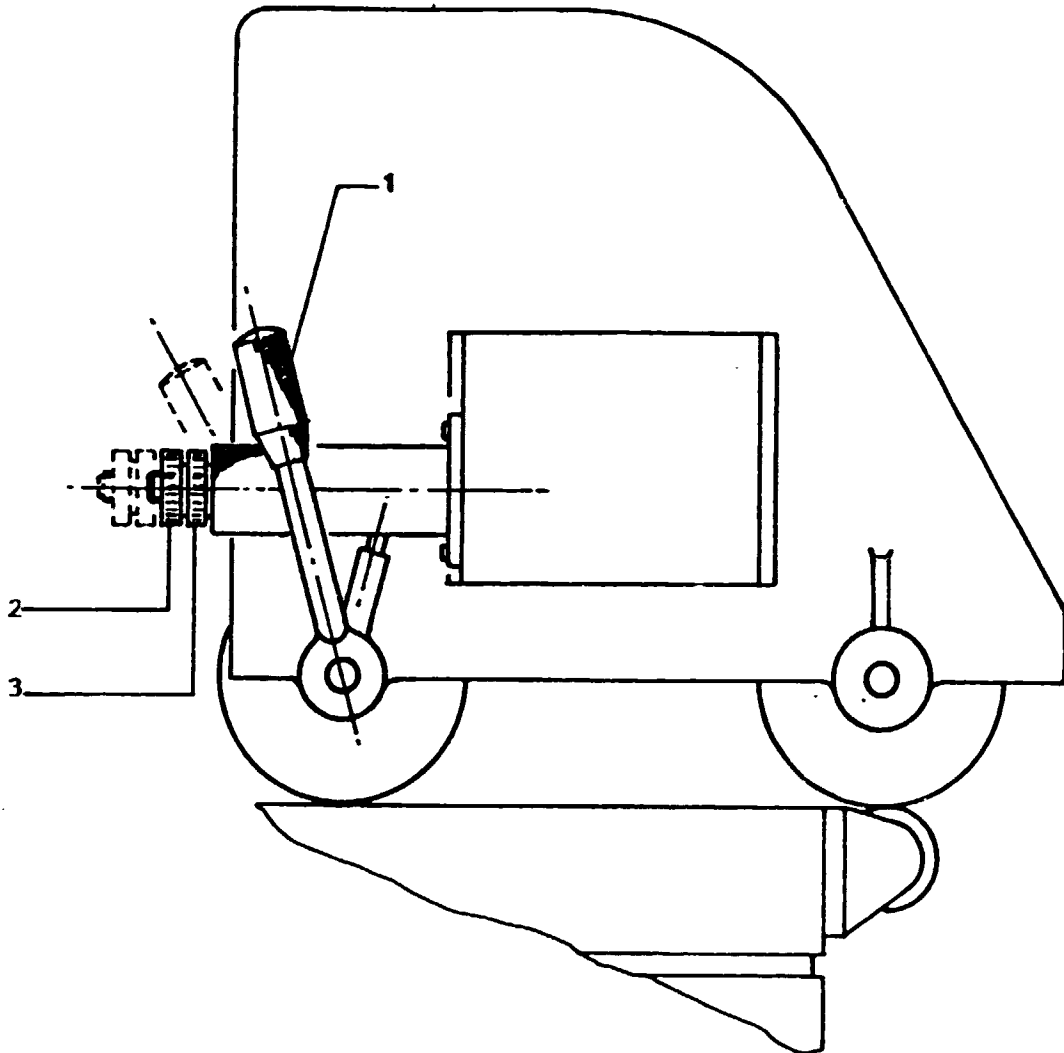

Fig. 12: Thermoplastic thread pressing roller:
(1) lever for lifting the pressing roller, (2&3) screws to regulate
the distance of the spring.

8. Thermoplastic thread for joining veneer

Thermoplastic thread is a synthetic hot melting glue in the form of a thread coiled and is used on a zigzag veneer joining machine for joining veneer sheets. It sticks not only to veneer, but to other materials as well. The sponge adhering to the pressing (dragging) roller must always be damp with separating liquid to avoid that the thermoplastic thread sticks to the roller.

9. Organization of the work area

The veneer trimming and joining work area can be organized as shown in Fig. 13.

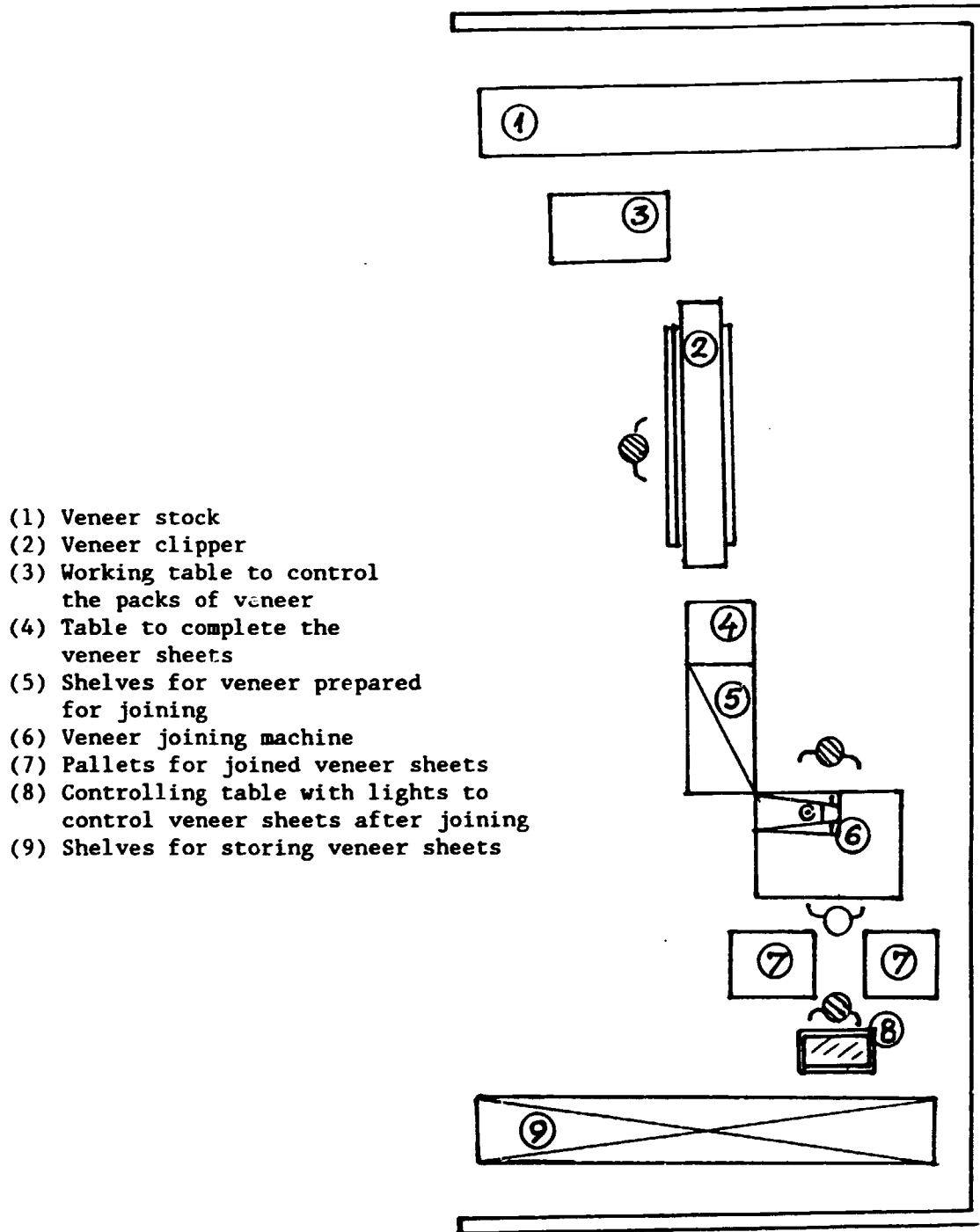

Fig. 13: Veneer trimming and joining area.

The veneer stock (1) is placed close to the veneer clipper (2). The table (3) is used for controlling the selected packs of veneer, and the table (4) for completing the veneer sheets according to the required widths and quality. The completed veneer sheets are stored on the shelves (5) next to the zigzag veneer joining machine (6). The joined veneer sheets are placed on the pallets (7) and controlled, if necessary repaired on the veneer control table (8). The inspected veneer sheets are stored on the shelf (9), ready to be taken to the next department and used for veneering.

The veneer clipper is operated by one operator, the joining machine by one operator and an assistant, and the controlling/repairing operation is performed by one operator.

10. Operating instructions for veneer joining machine

These instructions pertain to the veneer joining machine "ZAGFILO 80, Mod. 1100" and the numbers relate to those used in figures 9, 10, 11 and 12 in chapter 7.

First, the general switch -Fig. 9 (2)- has to be turned on. The sponge carrying tank -Fig. 11 (6)- should be filled with the separating fluid SINT-P2. The switch for resistance ignition -Fig. 10 (1)- is then turned on. A needle -Fig. 11 (2)- is used to put the thermoplastic thread -Fig. 11 (1)- into warming resistance for the thermoplastic wire -Fig. 11 (3)-. The pliers -Fig. 11 (5)- should be used for drawing out the needle and thermoplastic thread. If necessary, the knob for setting the resistance temperature -Fig. 10 (2)- is used to adjust the resistance temperature. The switch for ignition of motor of the machine -Fig. 10 (3)- is then turned on. The veneer drive using the lever -Fig. 9 (5)- is closed and the fly-wheel speed is adjusted with the governor -Fig. 9 (4)-. The small contact brush -Fig. 11 (4)- should be checked for contact. The timer -Fig. 10 (4)- should be adjusted for the ejection of pieces. The manual ejector of the end piece should be used. The pedal -Fig. 9 (3)- is used for blocking the machine in an emergency.

An attempt to joint two pieces of veneer should be made and the result checked. The joint must be even, smooth, without openings or overlaps. The thermoplastic thread must be melted and well pressed onto the veneer surface in a zigzag line. If necessary, the pace of the zigzag gluing line should be adjusted by changing the feeding speed. Single pieces should first be joined in pairs, then the pairs with each other. Care must be taken that the steam roller is kept wet with no glue stuck on it. Once the work is finished, all switches should be turned off and the machine cleaned.

11. Safety measures for the veneer joining operation

Apart from general safety rules, the operator must be aware that the resistance heating pipe should not be touched with the hands, thus avoiding burns. The hands must also be far from the steam roller when the machine is working.

Cleaning the machine and disconnecting the resistance when the machine is not operating are important safety and fire prevention measures.

12. Veneer controlling table

This is a box-like working table with a glass top and with neon tube lights below the glass. The surface of the table should correspond to the largest veneer sheets to be joined. In the case of the Pilot Furniture Plant, it is 1700 x 600mm.

The veneer sheets are controlled visually on the controlling table. Defects and structural details on the sheets are easily noticeable.

13. Inspection of veneer sheets and repairing defects

The controlling criteria depends on the veneer grade required. The veneer must be of equal colour and grain structure, without openings or other damages, without knots, insect borings or discolourations.

If the ends of the veneer sheets show cracks caused by handling or improper joining, they must be fixed with gluing paper tape and a hand roller.

The veneer used for veneering less visible surfaces such as backs, sides, shelves, etc. can have the above defects which could be dissimulated by using putties, stains and other finishing methods. The veneer used for the concealed and least visible surfaces can have all defects except decay and openings which cannot be patched. Maximum care should be taken on the quality of face veneer since it contributes to the general appearance of the furniture item and reflects its quality.

ANNEX I

TRAINING PROGRAMME FOR FURNITURE MANUFACTURING

1. Introduction

This training programme is designed to accomplish the objective and outputs foreseen in the project "Assistance in the Establishment of a Pilot Furniture Plant" (DP/DRK/86/011).

Referring to the project document, the immediate objective is to "train wood technicians and machine operators in the efficient operation of all the machinery and maintenance of tools, so as to manufacture furniture of medium quality", and also to "train managerial staff in overall management techniques including introduction to the marketing of furniture products".

This objective will be achieved through the accomplishment of outputs Nos. 6, 8 and 10.

Output No. 6 states: "20 wood machinists, 10 assemblers and four team leaders trained in the efficient use of the available manufacturing equipment, able to manufacture furniture of medium quality acceptable for export."

Output No. 8 states: "Two wood technicians trained to design and make the required production fixtures aimed at attaining accurate machining of components parts."

And output No. 10 states: "Design of overall factory organization, with established work preparation, cost accounting and management procedures, with managerial staff trained in (a) factory management based on modern industrial production methods and in (b) the basic elements of marketing."

The planned activities of the quoted outputs are:

For output No. 6:

- 6.1 Prepare a training programme for furniture manufacturing.
- 6.2 Prepare a training manual for each of the major production operations.
- 6.3 Train 20 machine operators, 10 assemblers and four team leaders to manufacture furniture of acceptable quality.

For output No. 8:

- 8.1 Train two wood technicians to design, produce and maintain jigs and other furniture production fixtures.

For output No. 10:

- 10.3 Train factory management in modern industrial production methods.
- 10.4 Acquaint the managerial staff with the basic elements of export marketing.

Training labourers is an integral part of production in modern industrial enterprises. Technical and technological developments are offering, practically

on a daily basis new products and methods which make human work easier, safer and more productive. To follow such advances, people working in industry have to learn and to train in order to acquire new knowledge and skills necessary for the handling of modern equipment and processes.

In developing countries, such training has a decisive importance for the fuller utilization of new production techniques and for mastering new technological processes. To avoid unnecessary mistakes and to gain indispensable skills, training courses are the most rational mode, because people can learn, in a short time, the best ways of performing their production duties.

2. Training programme for the Pilot Furniture Plant

This training programme is designed to meet the specific requirements of the Pilot Furniture Plant. The main topics covered in the programme are:

1. Wood, affiliated products and other materials used in the production of case furniture;
2. Furniture products: design, construction and quality standards;
3. Production organization and work preparation;
4. Panel sizing;
5. Veneer trimming and joining;
6. Veneering;
7. Processing of veneered furniture parts: trimming, tenoning edge banding and drilling;
8. Moulding and routing;
9. Sanding;
10. Finishing;
11. Preassembling, assembling and packaging;
12. Tools, jigs and measuring instruments;
13. Quality control;
14. Safety measures in the furniture production;
15. Management based on modern industrial production methods;
16. Basic elements of marketing.

The main goals of this training are to enable workers, not only to learn how to perform their jobs, but also to understand the industrial production system as a whole.

Courses numbers 1, 2, 3, 12, 13 and 14 are foreseen to be attended by all workers to be trained, while the other courses are intended only for the workers who will perform the respective production operations.

All these courses are independent from one another, but in their totality they represent an integral training programme for the production of casegoods furniture in a medium size factory.

3. Methodology of training

There is an old Chinese wisdom which says "What I hear I will forget, what I see I will remember, and what I have done I will know." The output of this training should be knowledge learned by workers who will increase their ability

for effective production. To achieve this, the training method will rest on three steps as follows:

1. Explain (to hear).
2. Demonstrate (to see), and
3. Try (to do).

Short manuals, written in a simple language, understandable to the workers, will be prepared for each course, translated into Korean and distributed to the trainees. All graphs, tables and formulae will be adjusted to the level of understanding of the people to be trained.

Theoretical teaching will take place in a classroom and its duration will be adapted to the minimum of theory which has to be known for a certain job. This part of the teaching will be performed by the expert (CTA) and the Chief of the Technical Department in the Pyongyang Wood Processing Complex (PWPC).

The practical part of the training will be organized at work areas for the respective work operations. For that purpose, the work areas must be organized correctly, including production documents, materials, tools, jigs, gauges, pallets, protective devices and everything that is necessary for productive, safe and good quality work. The expert will explain and show how to check a machine, tools, jigs and, in the case of wrong adjustments, how to correct them and prepare the equipment for correct use. The expert will show the correct way of performing operations and continue to supervise these operations until he concludes that proper work is fully accepted and that the quality of production is satisfactory.

The Chief of the Technical Department and other engineers who have undertaken training abroad will also collaborate in performing this practical training. Some practical experience of the trainees will help in the practical part of training.

Course No. 12 (tools, jigs and measuring instruments) should be conducted by the Tool Maintenance Expert.

Course No. 13 (Quality control). The manual prepared during the CTA's first mission can be used.

Courses Nos. 15 and 16 ("Management based on the modern industrial production methods" and "Basic elements of marketing") are foreseen for the managerial staff and will be conducted in a way to initiate discussion and an active participation of the trainees.

4. Selection of trainees

The persons to be trained will be selected by the counterpart, according to their duties and to the topics of the training programme. Besides workers who will directly perform particular production operations, all other people concerned with certain aspects of the production, such as foremen, members of the management, maintenance personnel etc. could be included in the training.

It is recommended that in selecting the trainees attention should be paid that their physical and psychological abilities be in accordance with the requirements of the pertinent jobs.

The list of trainees is an integral part of the training programme, and it determines the number of copies of the training manuals to be prepared and distributed for every course.

5. Training programme

TITLE	TRAINING HOURS	
	Theoretical	Practical
1. Wood, affiliated products and other materials used in the production of case furniture	4.5	1.25
2. Furniture products: design, construction and quality standards.	2.75	0.5
3. Production organization and work preparation	4.75	2
4. Panel sizing operation	2.75	3.5
5. Veneer trimming and joining	2.75	4.5
6. Veneering	5	4.5
7. Processing of veneered furniture parts: trimming, tenoning, edge banding and drilling	4.5	9.25
8. Moulding and routing	2.75	4.75
9. Sanding	0.25	4.75
10. Finishing	4.25	6.75
11. Preassembling, assembling and packaging	4.5	8.5
12. Tools, jigs and measuring instruments	5.75	4
13. Quality control	5	2.5
14. Safety measures and work protection in the furniture industry	5.5	1.25
15. Management of production in a modern industrial factory	10.25	4
16. Basic elements of marketing	5.25	-
GRAND TOTAL	70.50	62.00

Detailed syllabi for each topic are given in Annex II.

ANNEX II
DETAILED SYLLABI OF THE PROPOSED TRAINING COURSE

Topic 5: Veneer Trimming and Joining

ITEM	TOPICS	TRAINING TIME (in hours)		LEVEL OF COMPETENCE TO BE REACHED
		Theoretical	Practical	
5.1	Introduction	0.25	--	Understanding the purpose of the course.
5.2	Utilization of veneer and veneer cutting lists	0.25	--	Ability to understand and use a cutting list. Knowledge of the principles of utilization of veneer.
5.3	Veneer trimming machine	0.5	1	Knowledge of the construction, working principles and use of the veneer trimming machine.
5.4	Veneer trimming tools	0.25	0.25	Knowledge of the characteristics of tools and basic maintenance requirements.
5.5	Operating instructions for veneer trimming machine	--	1	Ability to operate correctly and control a veneer trimming machine.
5.6	Safety measures for veneer trimming operation	0.25	0.25	Understanding the dangers of improper use of the machine and measures for work safety.
5.7	Veneer joining machine	0.5	0.5	Knowledge of the construction, working principles and use of a veneer joining machine.
5.8	Thermoplastic thread for joining veneer	0.5	--	Knowledge of the thermoplastic gluing material for joining veneer and its advantages.
5.9	Organization of work area for veneer joining operations	-	0.25	Ability to organize the work area to ensure a rational utilization of time and workers' energy.
5.10	Operating instructions for veneer joining machines	-	1	Ability to operate and control a veneer joining machine.
5.11	Safety measures for veneer joining operations	0.25	-	Understanding safety measures in order to prevent injuries and damages to the machine and the veneer sheets.
5.12	Veneer quality controlling table	0.25	-	Knowledge of the function and use of a veneer quality controlling table.
5.13	Inspection of veneer and repairing defects	-	0.25	Ability to recognize defects and to repair them. Understanding quality standards for veneer.
TOTAL		3.00	4.50	