



TOGETHER
for a sustainable future

OCCASION

This publication has been made available to the public on the occasion of the 50th anniversary of the United Nations Industrial Development Organisation.



TOGETHER
for a sustainable future

DISCLAIMER

This document has been produced without formal United Nations editing. The designations employed and the presentation of the material in this document do not imply the expression of any opinion whatsoever on the part of the Secretariat of the United Nations Industrial Development Organization (UNIDO) concerning the legal status of any country, territory, city or area or of its authorities, or concerning the delimitation of its frontiers or boundaries, or its economic system or degree of development. Designations such as “developed”, “industrialized” and “developing” are intended for statistical convenience and do not necessarily express a judgment about the stage reached by a particular country or area in the development process. Mention of firm names or commercial products does not constitute an endorsement by UNIDO.

FAIR USE POLICY

Any part of this publication may be quoted and referenced for educational and research purposes without additional permission from UNIDO. However, those who make use of quoting and referencing this publication are requested to follow the Fair Use Policy of giving due credit to UNIDO.

CONTACT

Please contact publications@unido.org for further information concerning UNIDO publications.

For more information about UNIDO, please visit us at www.unido.org



POLSERVICE
FOREIGN TRADE ENTERPRISE

Chałubińskiego 8
00-613 Warszawa
Poland

telefon 30-05-22
tlx 813539 upol pl
telex 27-81-02

05P
-2000
10.06.92
10.06.92

20118

Hot kiln alignment

BY



GEOSERVEX
ENGINEERING MEASUREMENTS ENTERPRISE LTD

BYDGOSZCZ POLAND

F I N A L R E P O R T

REPORT ON HOT KILN ALIGNMENT OF THE ROTARY
KILNS OF HAWARI AND BENGHAZI CEMENT PLANTS

IN BENGHAZI - LIBYA

TIME OF EXECUTION :

N O V E M B E R 1992

F I N A L R E P O R T

I. FORMAL DATA

1. Order issued by : United Nations Industrial
Development Organization
Vienna - Austria
2. Executor : POLSERVICE - Foreign Trade Enterprise
Warsaw - Poland
3. No. of contract : 92 / 212
4. Subject of contract: Measurements of axial deformations
and adjustments of the rotary
Kilns no 1 and 2 at " HAWARI"
Cement Plant in Benghazi
- L I B Y A -
5. Contract was carried out by: Engineering Measurements
Enterprise " GEOSERVEX "
Bydgoszcz - POLAND
6. Responsible person: Engg. Wieslaw PAUSZEK (M.Sc)
7. Time of execution : NOVEMBER 1 9 9 2 .
8. Additional arrangements : By request of "Hawari"
Cement Plants Representatives
an additional measurement of kiln
no 3 was taken.(short programme)

II. DOCUMENTATION

Documentation on all measurements and adjustments was prepared separately for each Kiln and is enclosed in appendixes which are the integral part of this report.

Appendix no 1 - regarding the kiln no 1 of Hawari Cement Plant contains 14 pages of conclusions and drawings.

Appendix no 2 - regarding the kiln no 2 of Hawari Cement Plant contains 14 pages of conclusions and drawings.

Appendix no 3 - regarding the kiln no 3 of Benghazi Cement Plant contains 9 pages of conclusions and drawings.

III. CONCLUSIONS

1. Conclusions were presented and prepared separately for each kiln and are included in appendixes no1 and2 of the above mentioned documentation.
2. Hawari Cement Plant Representatives were fully informed about all measurements and adjustments which were carried out and received the whole documentation. Two copies of this documentation were passed on to Hawari Cement Plant Representatives on 26th of Nov.1992.

3. Final R E P O R T was signed on 26th Nov, 1992

On behalf of Haveri Cement Plant it was signed by:

Mr EL - ZADIN

On behalf of POLSERVICE it was signed by:

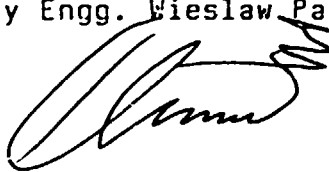
Mr Ryszard Szelagowski (M.Sc. Engg.)

IV. ADDITIONAL REMARKS

Appendix No 4 contains some explanations about our technique of measurement and adjustment called "HOT KILN ALIGNMENT". All materials included in this appendix are to be used as training materials and informations.

T H E F I N A L R E P O R T

was elaborated by Engg. Wieslaw Pauszek (M.Sc)



" G E O S E R V E X " - B Y D G O S Z C Z - P O L A N D

3rd of Dec. 1992



POLSERVICE

FOREIGN TRADE ENTERPRISE

*Chałubińskiego 8
00-613 Warszawa
Poland*

*telefon 30-05-22
tlx 813539 upol pl
telefax 27-81-02*

A P P E N D I X No 1

Hot kiln alignment

BY



GEOSERVEX

BYDGOSZCZ POLAND

ENGINEERING MEASUREMENTS ENTERPRISE LTD

kiln no. 1

HAWARI

The Libyan Cement Company
The Industrial Complex
for Cement and Building Materials

شركة لا اجراء
Established on 1965 - 4 - 4



REPORT ON HOT KILN ALIGNMENT OF 2.500 TPD, DRY PROCESS,
3 SUPPORT KILN OF M/S THE LIBYAN CEMENT COMPANY,
BENGAZI-HAVARI , LIBYA.

Hot Kiln Alignment of the above kiln was carried out with the aid of Optico-Mechanical method, based on Patent authorised to Mr B. Krystowczyk (Ph.D.Engg).

1.0 SCOPE OF WORK

The scope of work includes following:

- 1.1 Measurement of kiln axis in horizontal and vertical planes during the kiln operation.
- 1.2 Measurement of support rollers axis in horizontal and vertical planes.
- 1.3 Measurement of undertyre clearance by means of differential method during the kiln operation.
- 1.4 Calculation of the deviation of the actual kiln axis from optimal axis in horizontal and vertical planes by a computer programme.
- 1.5 Calculation of rollers torsion and the adjustment required.
- 1.6 Working out the schedule for rollers adjustment with the participation of LCC's representatives.
- 1.7 Checking measurements after the adjustment.

2.0 Measurements were carried out by representatives of Budexpol-Polservice from 2nd Nov. 1992 to 21st Nov. 1992.

3.0 The results of above measurements are as below:

3.1 The deviations of Kiln axis are as below (refer page No4)

Support No (from inlet end)	in vertical plane (mm)	in horizontal plane (mm)
1	0.0	0.0
2	1.0	1.0
3	0.0	0.0

3.2 The support roller axes torsion in vertical and horizontal planes were found within the tolerance (refer page No5)

3.3 The rollers working angles are found within the tolerance which for this type of Kiln should be $60^{\circ} \pm 1^{\circ} 30'$ (refer page No 4)

Support No	Angle
1	$59^{\circ} 55'$
2	$59^{\circ} 45'$
3	$59^{\circ} 50'$

3.4 The Kiln's inclination is accurately at 3.50%.

3.5 The undertyre clearance was measured by means of differential method on each tyre and the results are as below (refer page No 4,10)

Tyre No	<u>Undertyre clearance (mm)</u>
1	6.0
2	17.0
3	10.0

- 3.5 The undertyre clearances on supports 2 and 3 are incorrect and require some regulations. The proper value of such a clearance "in hot conditions" varies from 3 to 6 mm.
- 3.6 We have noticed that the clearance between girth gear and pinion was little (1/4 of the gear close to "Nil") It requires an adjustment by lifting the Kiln axis up.
- 3.7 As we were informed about frequent lining failure problems near the 2nd support tyre, A measurement of Kiln's shell deformations was taken (page 13) and during this measurement we have stated a big "crank" in sections 4 and 6 on both sides of the tyre. It also requires some adjustment.
- 3.8 The Kiln axes in horizontal and vertical planes are correct and do not require any adjustment. Rollers' torsions in horizontal plane require adjustment (page 7 shows the details). Rollers' torsions adjustment should be taken into consideration after reducing undertyre clearances on 2nd and 3rd supports.

4.0 CONCLUSIONS

To improve the Kiln's operation, it is necessary to undertake following:

- 4.1 Reducing big undertyre clearances by inserting undertyre shims,

- tyre No 2 - thickness of shims (6mm)
- tyre No 3 - thickness of shims (3mm)

We recommend to remove old shims and sum up the thickness with new ones.

4.2 It is also necessary to lift the 1st tyre axis up for 5 mm , which is going to increase the clearance between girth gear and pinion. (page 6)

4.3 Our proposals of above mentioned regulations are shown on pages 6,7 and 8 .

The adjustment shown on page 8 is to be done after inserting undertyre shims on 2nd and 3rd tyre.

- First of all , the rollers on 1st support have to be shifted for 8 mm (inside direction).
- Second step considering shifting rollers on 2nd support.
- Final step is to shift the rollers on 3rd support.

4.4 After the whole adjustment the Kiln axis and the rollers' torsions will be corrected(pages 11 and 12).

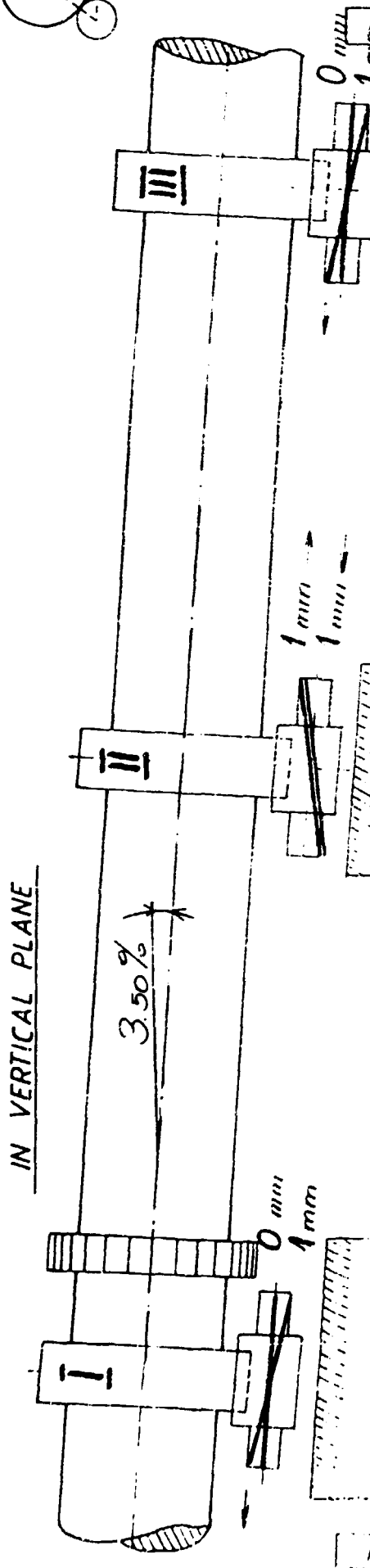
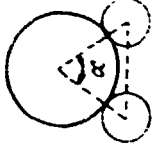
4.5 The "crank" could be wind up (liquidated) by cutting the Kiln's shell off in sections 4 and 6. Later on it is necessary to adjust the Kiln axis and weld the Kiln's shell again.

4.6 If the whole adjustment was carried out according to our suggestions it would certainly have a significant influence on decreasing lining failure and would reduce the number of unexpected stoppages.

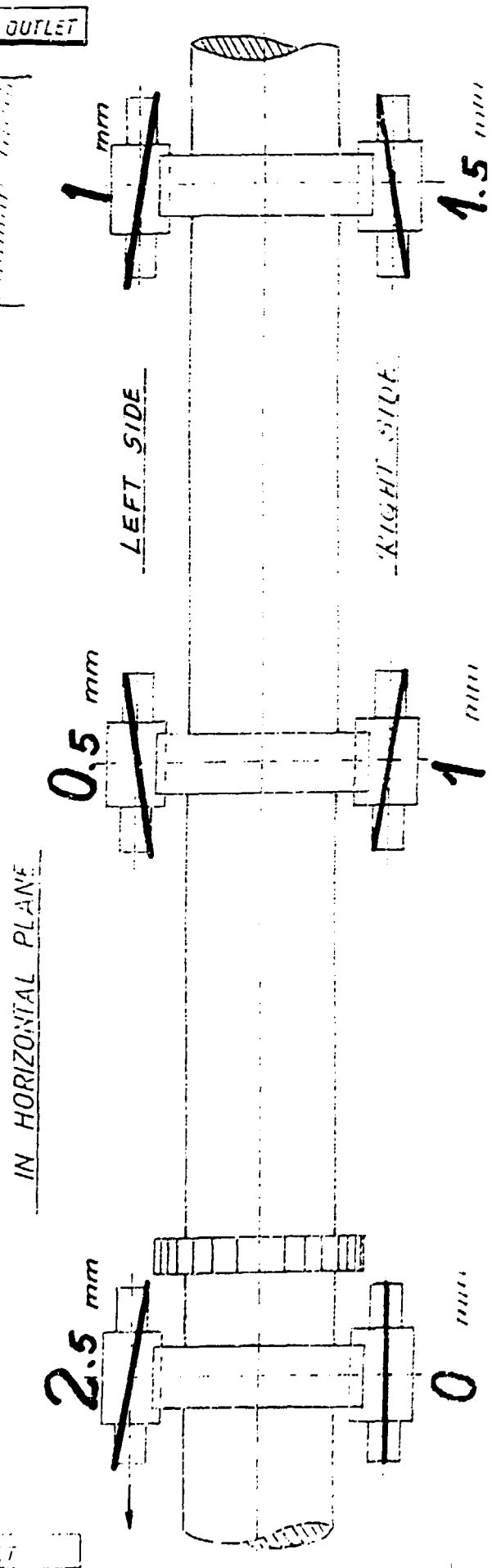
For BUDEXPOL - POLSERVICE


Engg. Wieslaw PAUSZEK (M.Sc.)

DIAGRAM FOR ROLLERS AXIS TORSION



IN VERTICAL PLANE



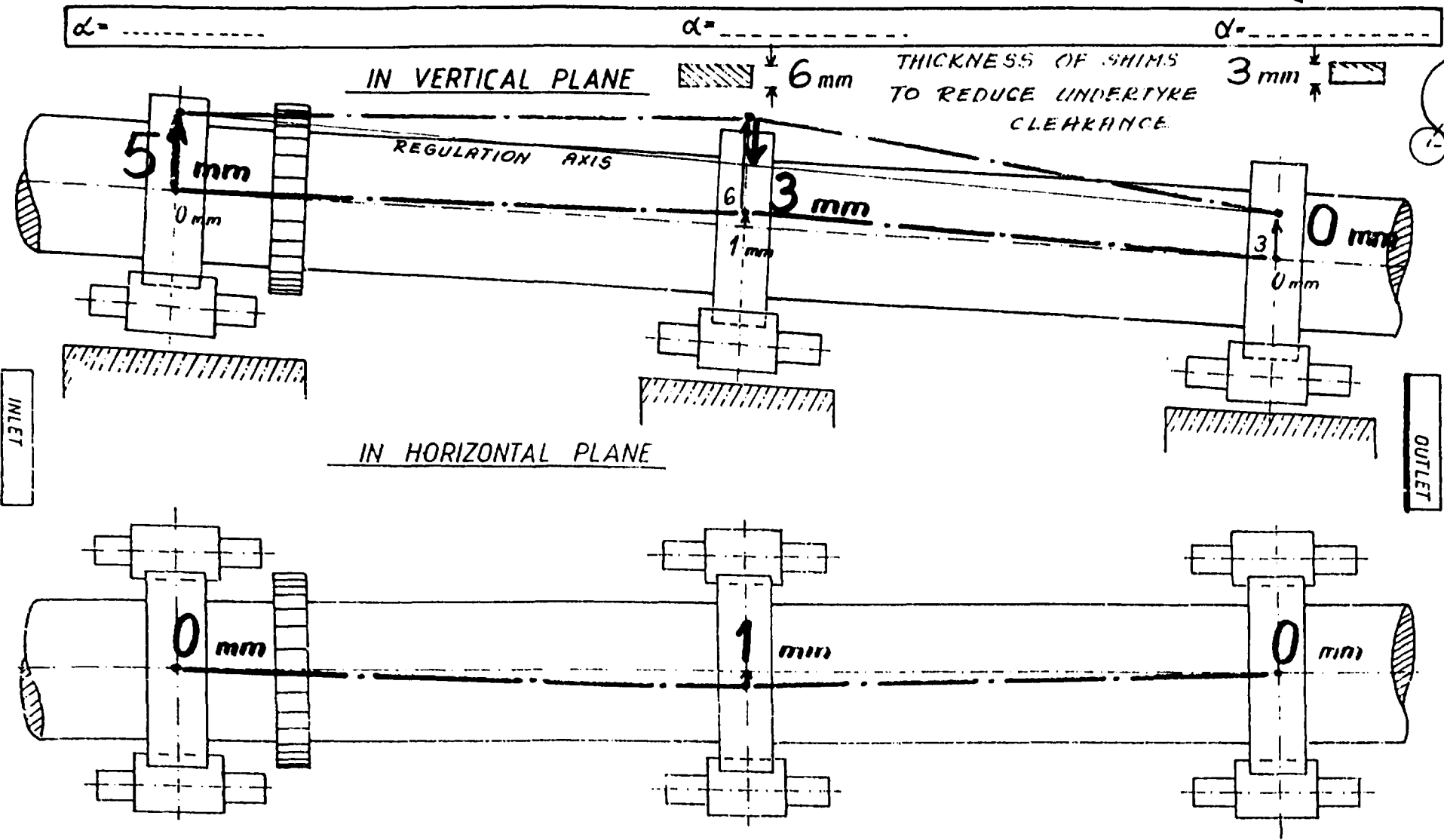
IN HORIZONTAL PLANE

LEFT SIDE

RIGHT SIDE

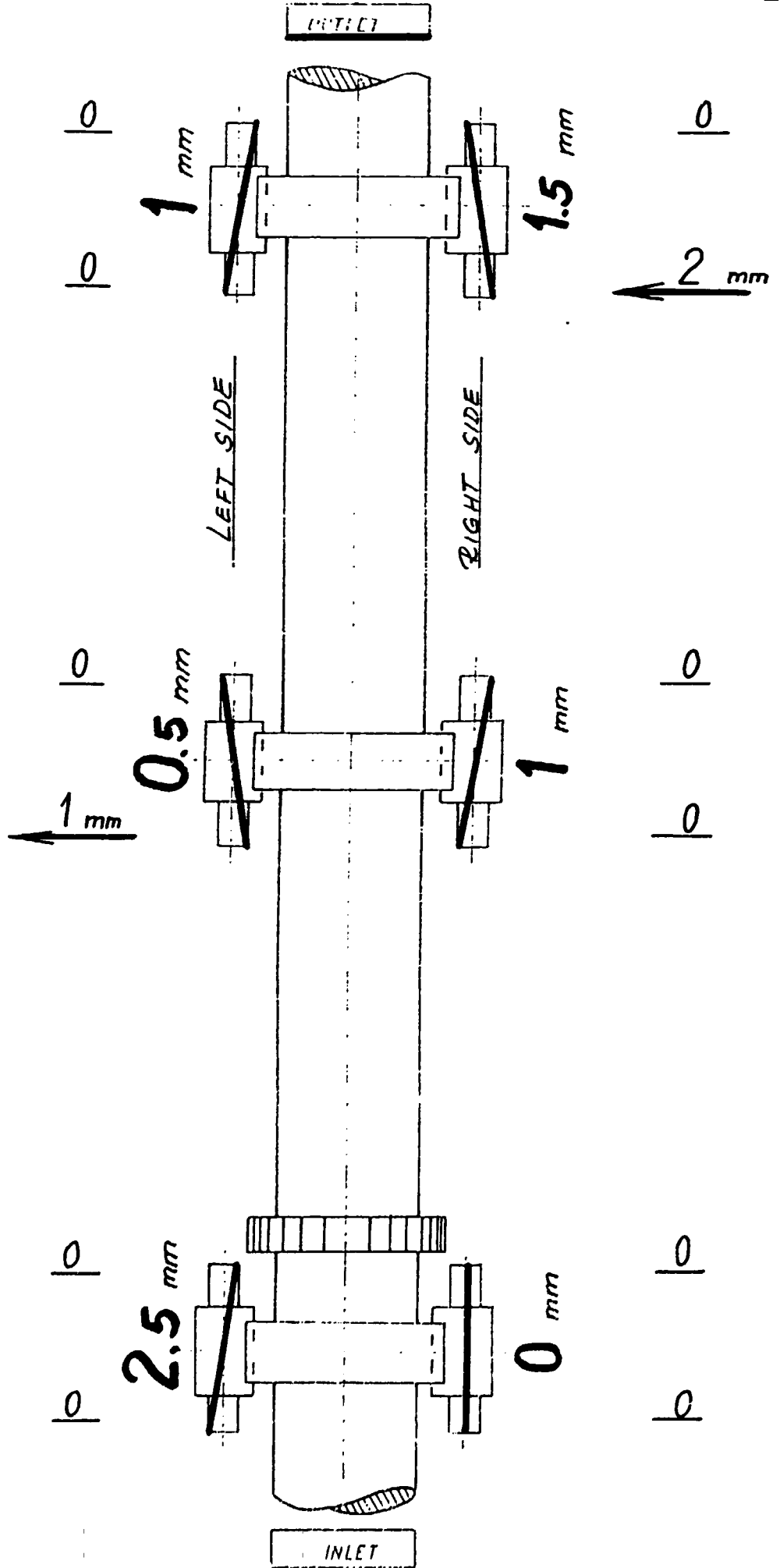


DIAGRAM OF AXIAL DEFORMATIONS - FOR REGULATION





SCHEDULE FOR ROLLERS AXIS TORSION ADJUSTMENTS

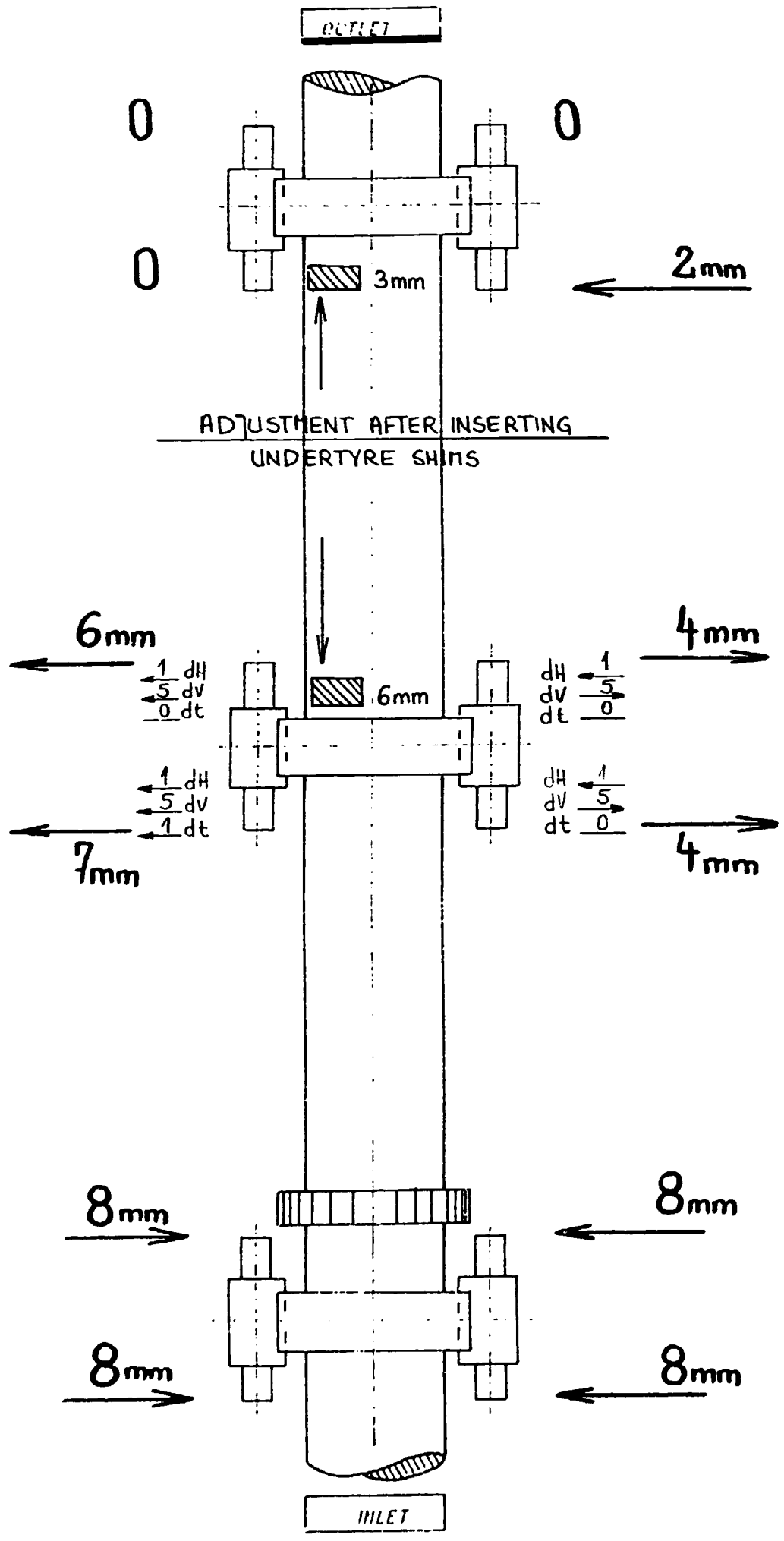


شركاء لا اجراء
Established on 1965 . 4 . 4



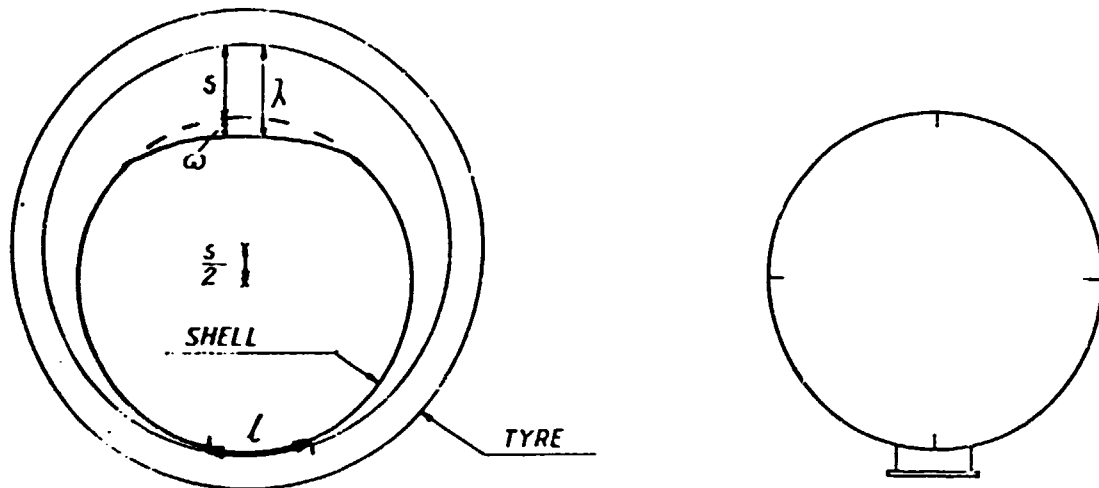
The Libyan Cement Company
The Industrial Complex
for Cement and Building Materials

SCHEDULE FOR REGULATION ADJUSTMENTS





KILN SHELL TOP CLEARANCE



1. l THE VALUE OF THE KILN SHELL SHIFT AGAINST THE TYRE AFTER ONE ROUND
2. λ THE VALUE OF A CLEARANCE BETWEEN TYRE AND THE KILN SHELL AS HAS BEEN MEASURED FROM THE SCHEDULE
3. S THE REAL UNDERTIRING CLEARANCE
4. ω A KILN SHELL BEND (OVALIZATION)

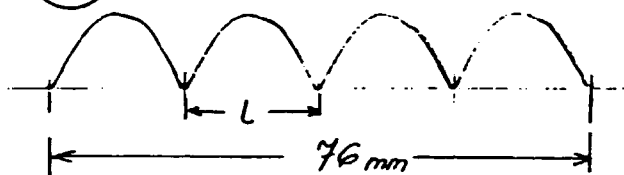
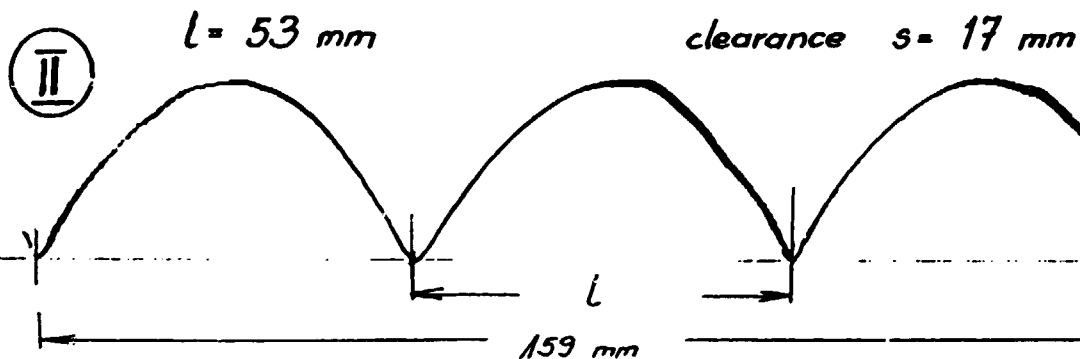
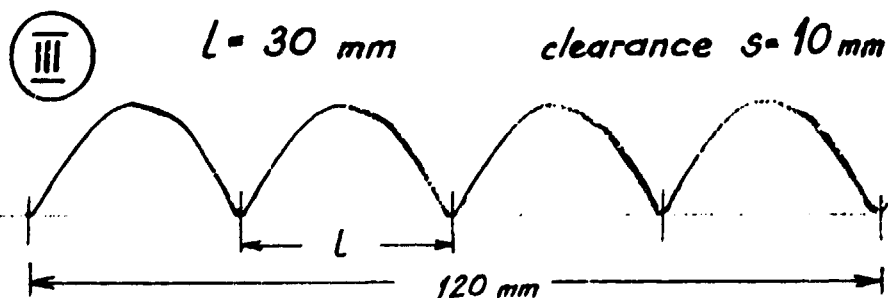
KILN No 1UNDERTIRING CLEARANCETYRE IDate of measurement.① $l = 19 \text{ mm}$ clearance $s = 6 \text{ mm}$ NOV. 9th 1992NOV. 12th 1992NOV. 17th 1992TYRE IITYRE III

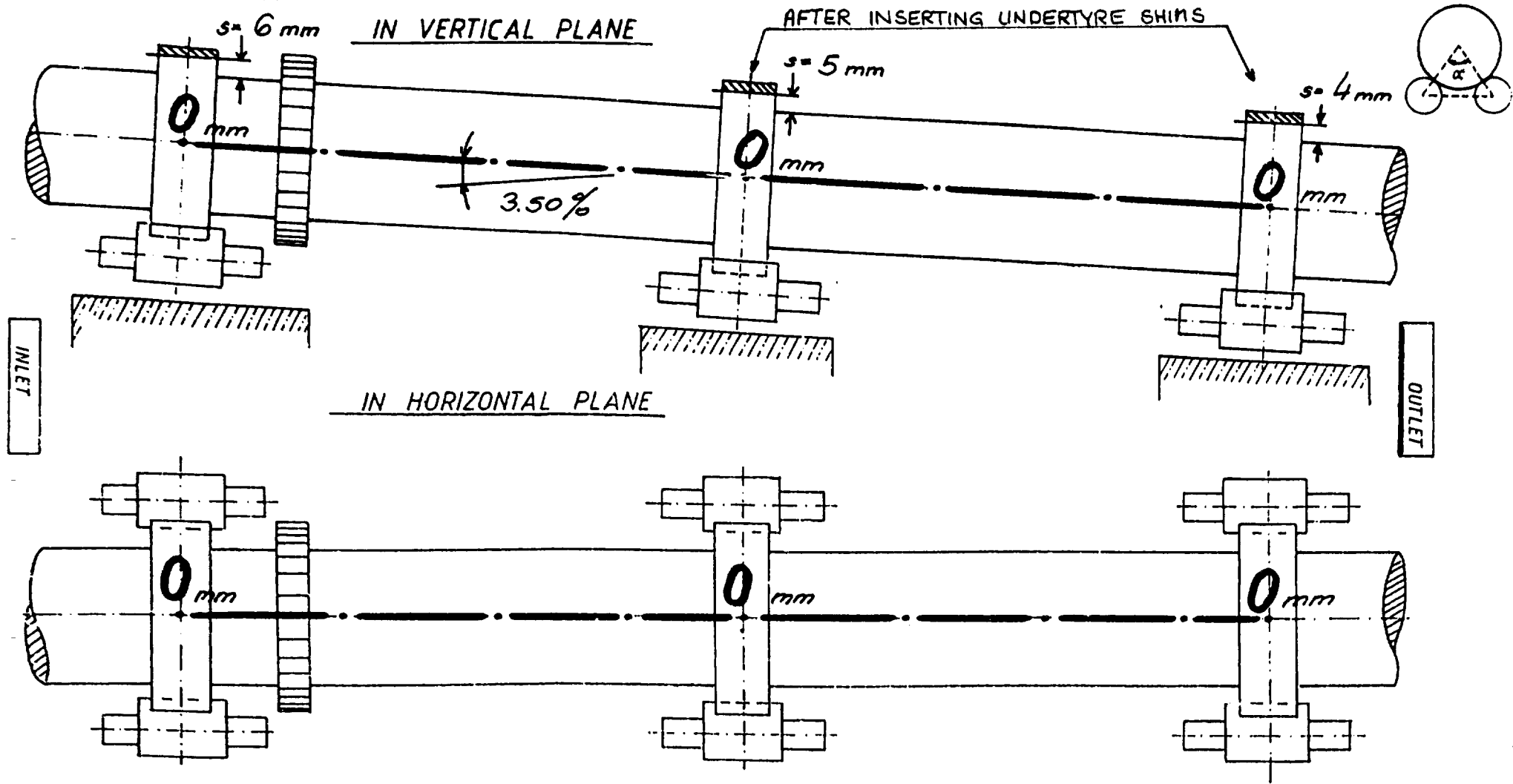


DIAGRAM OF AXIAL DEFORMATIONS AFTER ADJUSTMENT

$\alpha = 59^{\circ} 36'$

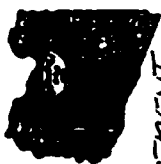
$\alpha = 59^{\circ} 56' \pm 5'$

$\alpha = 59^{\circ} 50'$



شركة لا اجراء

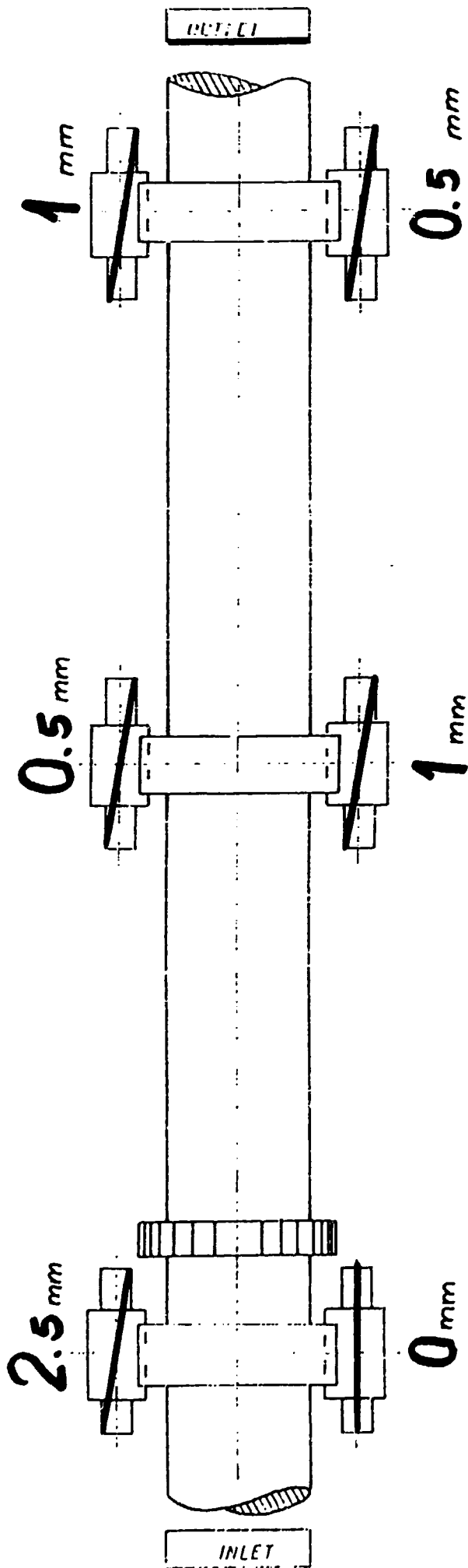
Established on 1965 . 4 . 4



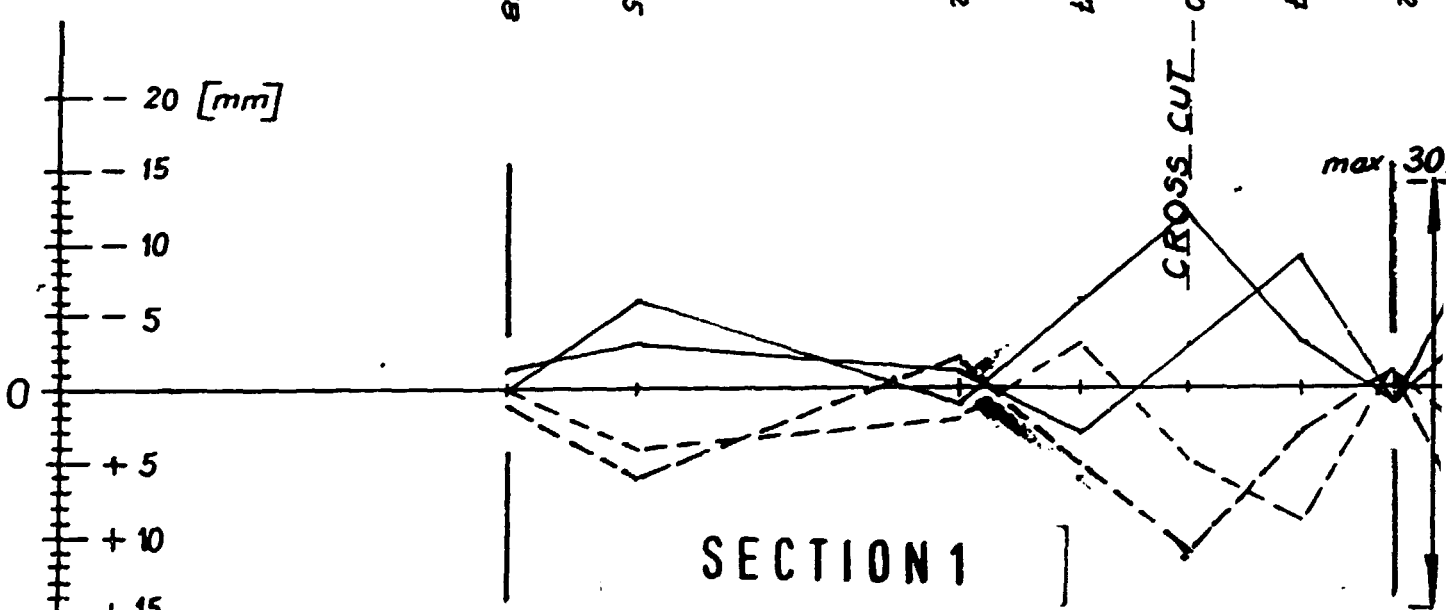
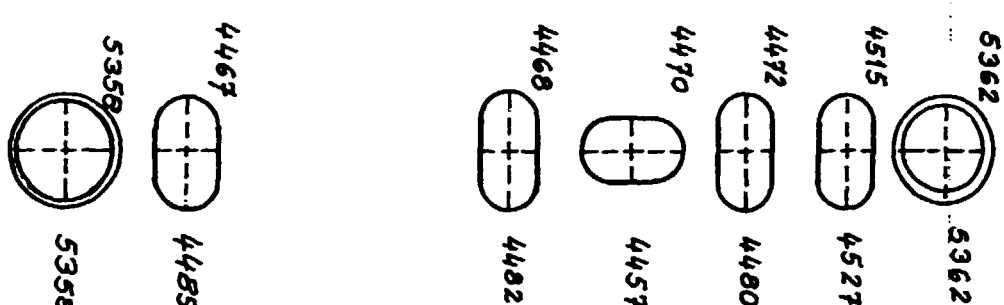
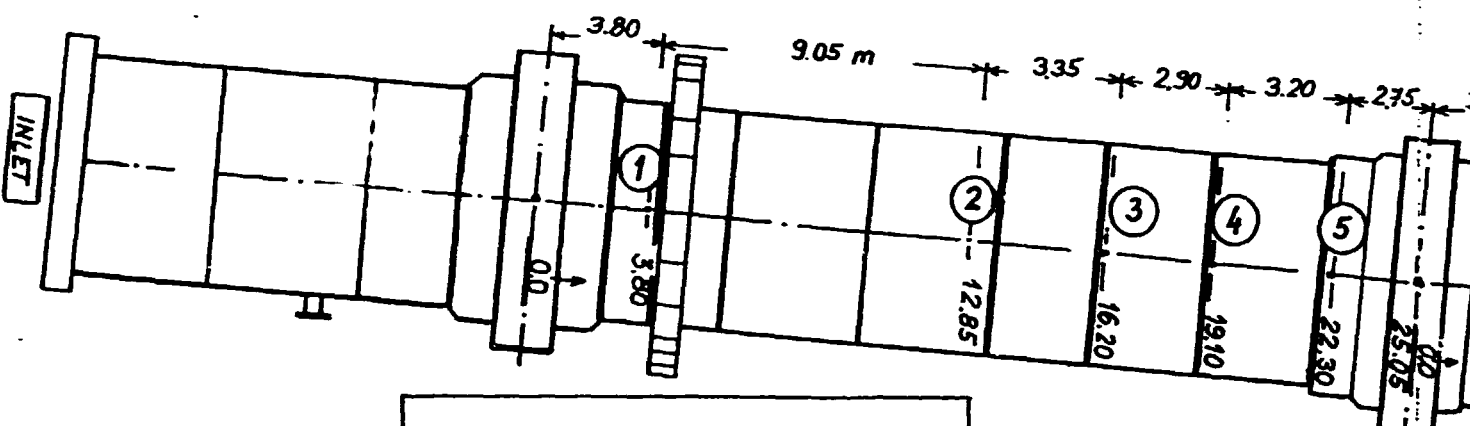
The Libyan Cement Company

The Industrial Complex
for Cement and Building Materials

SCHEDULE FOR ROLLERS AXIS TORSION AFTER ADJUSTMENT



KILN No 1

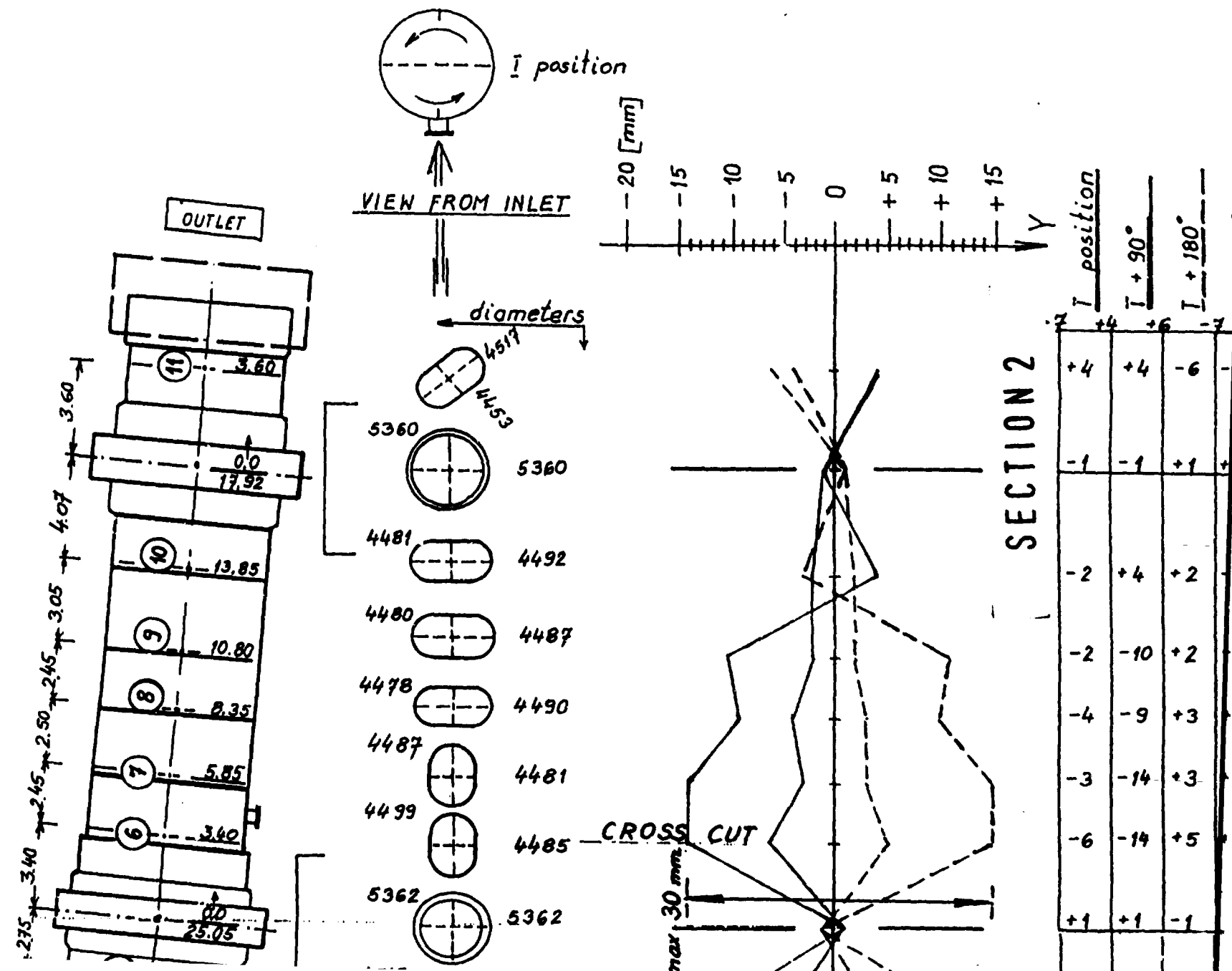


+1	+1	-1	-1
-9	-3	+9	+3
-3	-12	+5	+11
+3	-6	-3	+5
-1	+1	+2	-2
-1	0	0	+1
-3	-6	+4	+8
-1	0	0	+1

The Industrial Complex
for Cement and Building Materials



DIAGRAM OF THE KILN SHELL AXIS DEFORMATIONS





POLSERVICE

FOREIGN TRADE ENTERPRISE

Chałubińskiego 8
00-613 Warszawa
Poland

telefon 30-05-22
tlx 813539 upol pl
telefax 27-81-02

A P P E N D I X No 2

Hot kiln alignment

BY



GEOSERVEX

BYDGOSZCZ POLAND

ENGINEERING MEASUREMENTS ENTERPRISE LTD

kiln no. 2

HAWARI

The Libyan Cement Company
The Industrial Complex
for Cement and Building Materials

شركة لا اجراء
Established on 1965-4-4



REPORT ON HOT KILN ALIGNMENT OF 2.500 TPD, DRY PROCESS,
3 SUPPORT KILN OF M/S THE LIBYAN CEMENT COMPANY,
BENHAZI-HAWARI , LIBYA.

Hot Kiln Alignment of the above kiln was carried out with the aid of Optico-Mechanical method, based on Patent authorised to Mr B. Krystowczyk (Ph.D.Engg).

1.0 SCOPE OF WORK

The scope of work includes following:

- 1.1 Measurement of kiln axis in horizontal and vertical planes during the kiln operation.
- 1.2 Measurement of support rollers axis in horizontal and vertical planes.
- 1.3 Measurement of undertyre clearance by means of differential method during the kiln operation.
- 1.4 Calculation of the deviation of the actual kiln axis from optimal axis in horizontal and vertical planes by a computer programme.
- 1.5 Calculation of rollers torsion and the adjustment required.
- 1.6 Working out the schedule for rollers adjustment with the participation of LCC's representatives.
- 1.7 Checking measurements after the adjustment.

- 2.0 Measurements were carried out by representatives of Budexpol-Polservice from 2nd Nov.1992 to 21st Nov.1992.
- 3.0 The results of above measurements were presented before the LCC's representatives on 14th Nov.1992, which are as below:
- 3.1 The deviations of Kiln axis are as below (refer page No 4)

Support No (from inlet end)	in vertical plane (mm)	in horizontal plane (mm)
1	0.0	0.0
2	2.5	1.0
3	0.0	0.0

- 3.2 The support roller axes torsion in vertical and horizontal planes were found within the tolerance (refer page No 6)
- 3.3 The rollers working angles are found within the tolerance which for this type of kiln should be $60^{\circ} \pm 1^{\circ} 30'$ (refer page No 4)

Support No	Angle
1	$60^{\circ} 02'$
2	$59^{\circ} 56'$
3	$59^{\circ} 56'$

- 3.4 The Kiln's inclination is accurately at 3.51%.
- 3.5 The undertyre clearance was measured by means of differential method on each tyre and the results are as below (refer page No 4,9,10)

Tyre No	<u>Undertyre clearance(mm)</u>
1	2.0
2	7.5
3	12.0

The undertyre clearance of the tyre No 2 has been measured for six times and the real value of this clearance is 7.5 mm. However, during the measurement taken on the 6th of Nov.1992 a considerable difference was noticed when the clearance reached 12 mm. We can only presume that the reason of such differences was caused by a momentary change of the Kiln's shell temperature near the above mentioned tyre.

- 3.5 The undertyre clearances on supports 2 and 3 are incorrect and require further adjustment which should take place during the replacement of the Kiln's shell under tyre 2 and 3. The proper value of undertyre clearance " in hot conditions " is 3 to 6 mm.
- 3.6 During our measurements a considerable whipping of the tyre No 2 was noticed (upto 5mm) as well as a slight movement of supports 2 and 3 (upto 2mm), which is caused by an improper shape of the tyre No 2 and a " crank " movement of the Kiln.
- 3.7 The ovality of the 2nd tyre was measured in 8 different places around this tyre (page 11,12) Differences in diameters are exceeding 3 mm. Improper ovality of this tyre was probably caused by "overheating " the Kiln's shell under above mentioned tyre.
- 3.8 In addition a measurement of the Kiln's shell deformations was taken (page 13 shows the details) and a considerable deformations under the 2nd tyre were found. It is recommended to change this part in the nearest future.
- 3.9 Although, the Kiln's axes deviations were found within the tolerance , we decided to carry out a slight adjustment on the support No2 to reduce the friction on the 2nd tyre and to smooth the Kiln operation. The adjustment was taken on 16th and 17th of Nov. 1992. The checking measurement after aforesaid adjustment was taken on 18th of Nov. 1992.

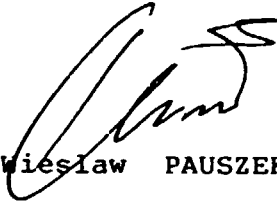
4.0 CONCLUSIONS

The Kiln's shell condition under 2nd and 3rd tyres is poor and some parts of the shell require to be changed. (the sooner the better). The Kiln's shell deformations cause a frequent lining failure.

- 4.1 Except a poor condition of the shell near the tyre No3 we have also noticed a great number of cracks.
- 4.2 Page 13 shows all the parts of the shell that should be changed (orange coloured parts)

4.3 After a proper replacement of recommended parts there should be a significant improvement in Kiln's operation , lining failures and the whole regulation should also improve production by decreasing other failure problems.

For BUDEXPOL - POLSERVICE



Engg. Wiesław PAUSZEK (M.Sc.)

DIAGRAM OF AXIAL DEFORMATIONS

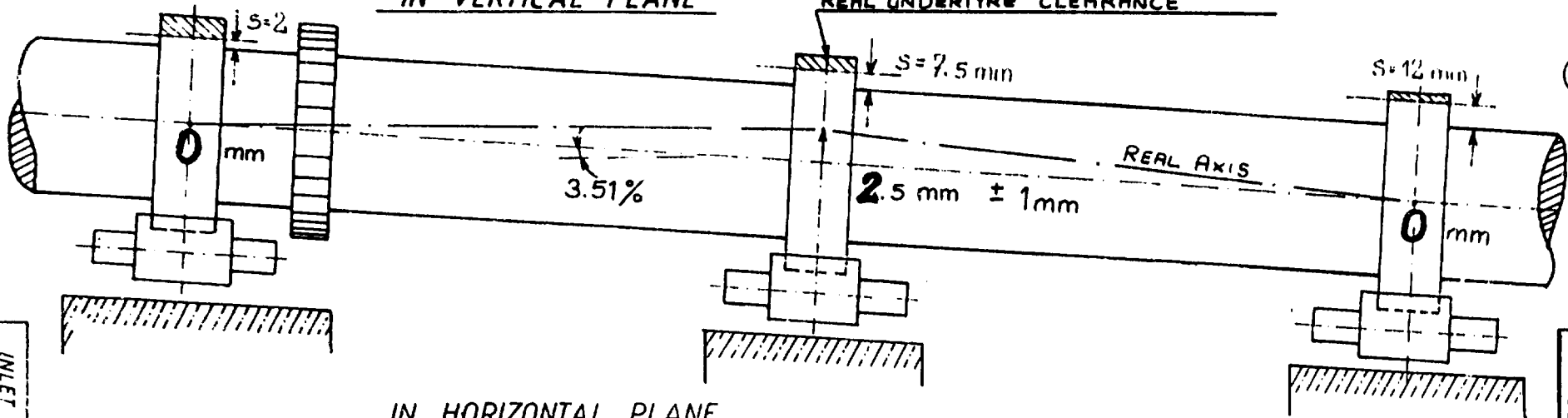
$\alpha = 60^{\circ} 02'$

$\alpha = 59^{\circ} 56' \pm 5'$

$\alpha = 59^{\circ} 56'$

IN VERTICAL PLANE

REAL UNDERTYRE CLEARANCE



IN HORIZONTAL PLANE

LEFT SIDE

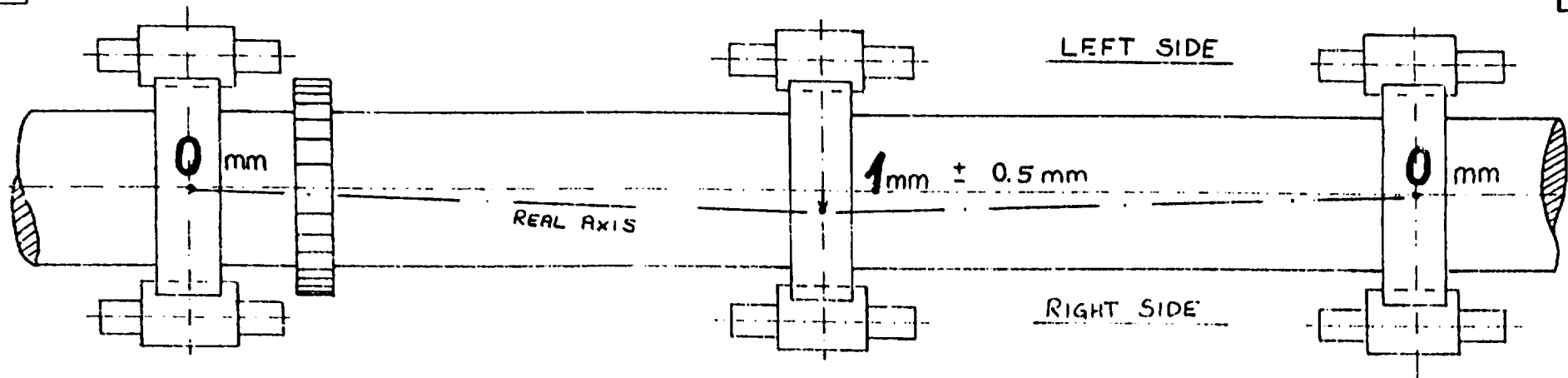
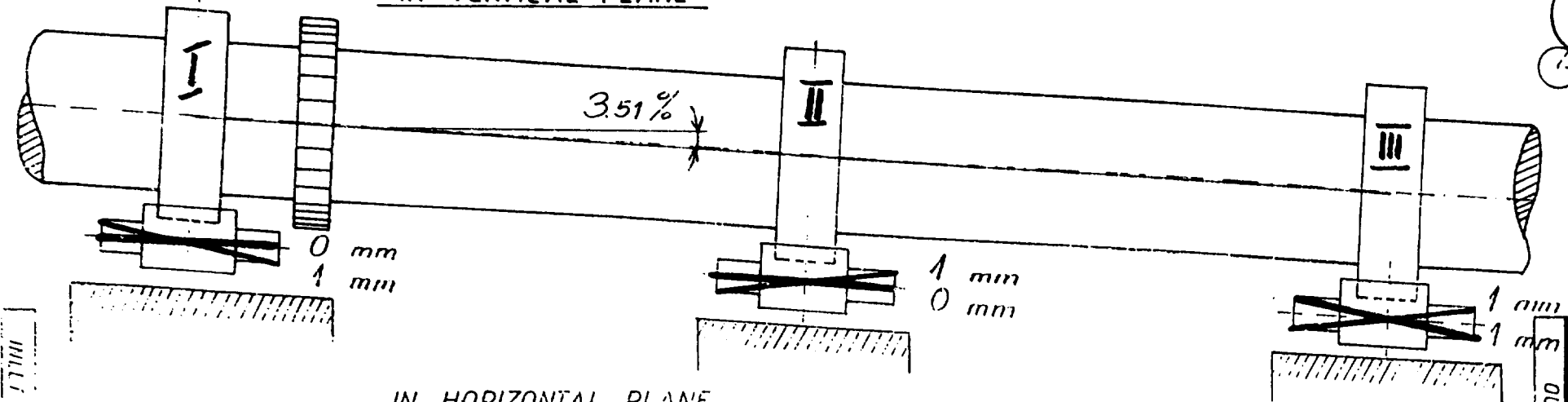


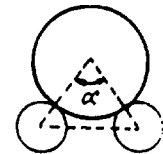
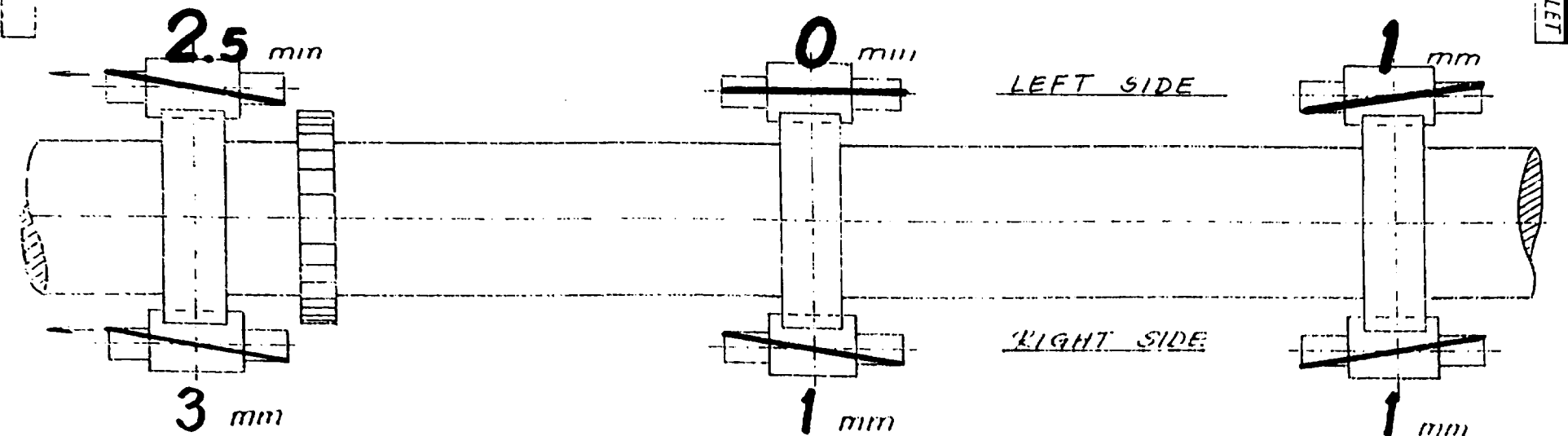
DIAGRAM FOR ROLLERS AXIS TORSION

$\alpha =$ $\alpha =$ $\alpha =$

IN VERTICAL PLANE



IN HORIZONTAL PLANE



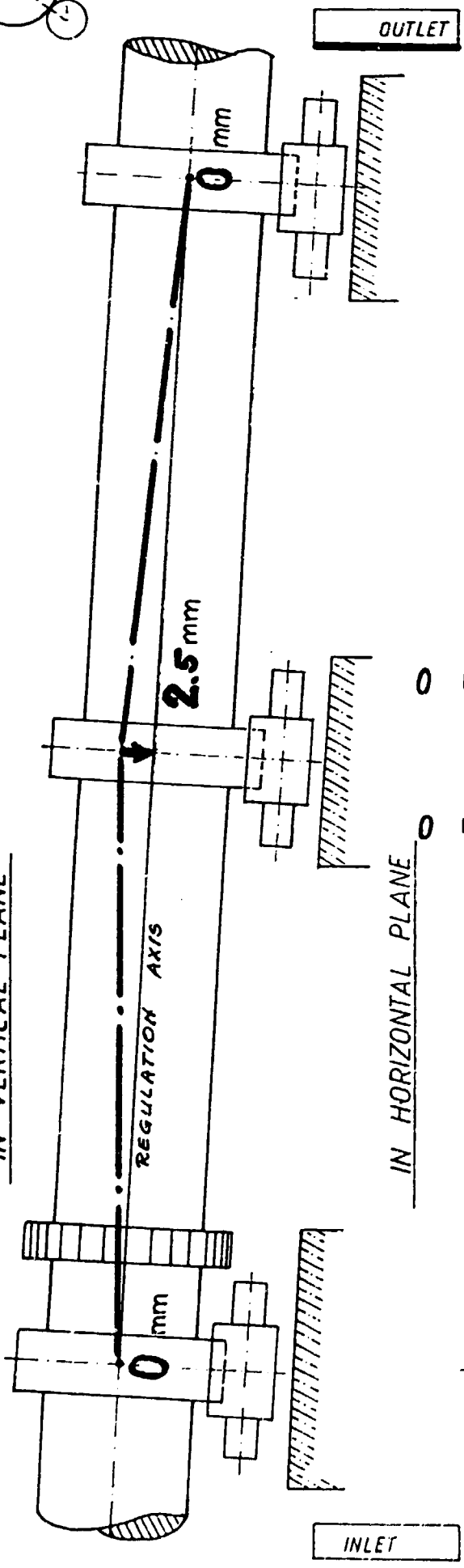
Established on 1953 - 4 - 4

The Industrial Complex
for Cement and Building Materials

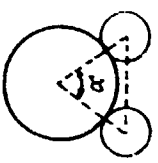
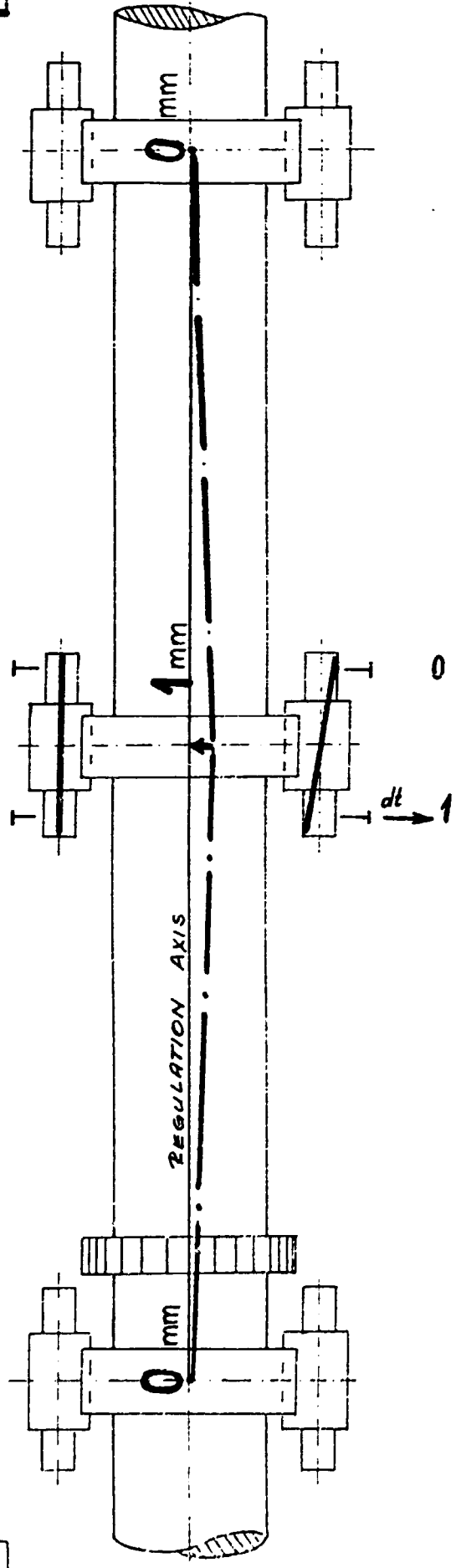
DIAGRAM OF AXIAL DEFORMATIONS—FOR REGULATION



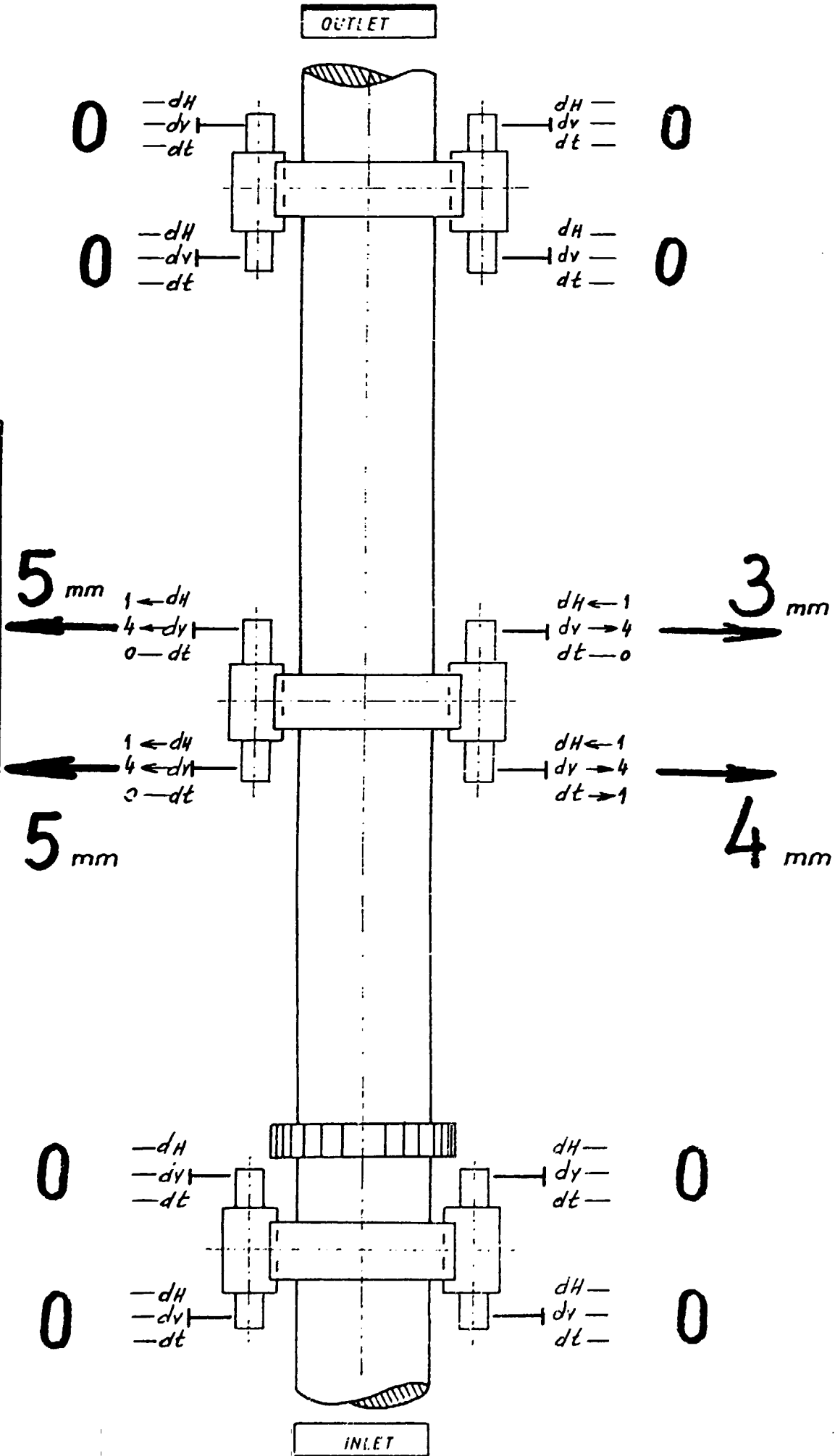
IN VERTICAL PLANE



IN HORIZONTAL PLANE

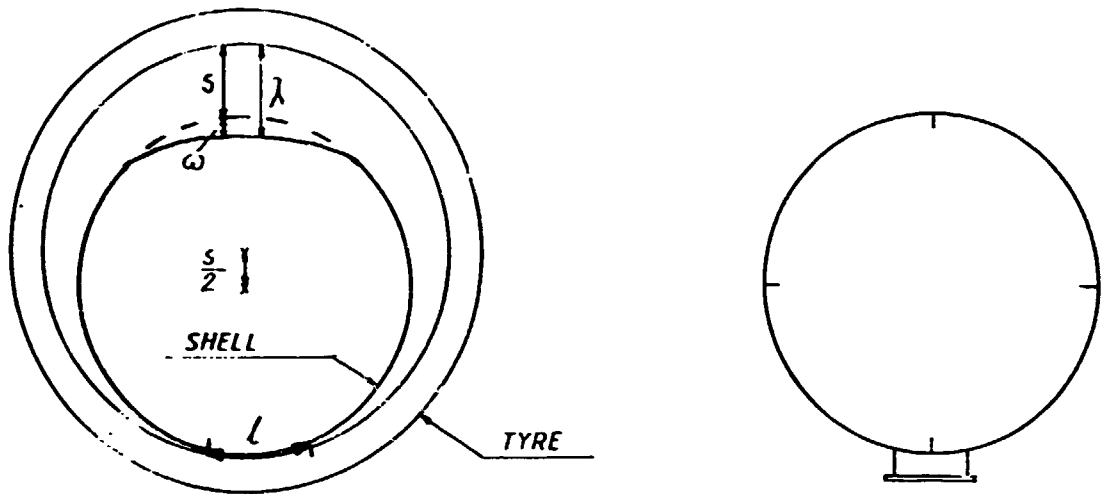


SCHEDULE FOR REGULATION ADJUSTMENTS





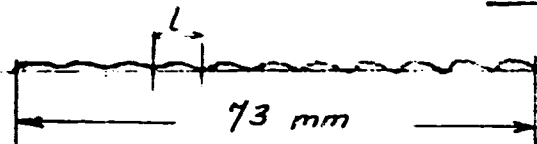
KILN SHELL TOP CLEARANCE



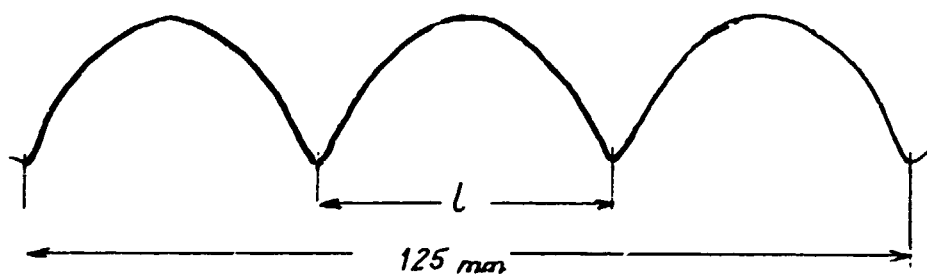
1. l THE VALUE OF THE KILN SHELL SHIFT AGAINST THE TYRE AFTER ONE ROUND
2. λ THE VALUE OF A CLEARANCE BETWEEN TYRE AND THE KILN SHELL AS HAS BEEN MEASURED FROM THE SCHEDULE
3. S THE REAL UNDERTIRING CLEARANCE
4. ω A KILN SHELL BEND (OVALIZATION)

KILN No. 2UNDERTIRING CLEARANCETYRE IMeasurement date

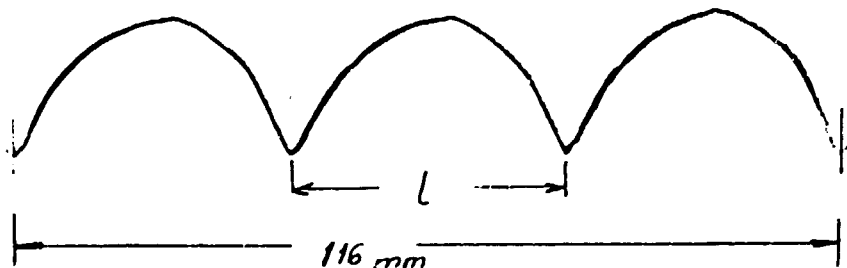
①

 $l = 6.6 \text{ mm}$ clearance $s = 2 \text{ mm}$ NOV. 5th 1992TYRE III

③

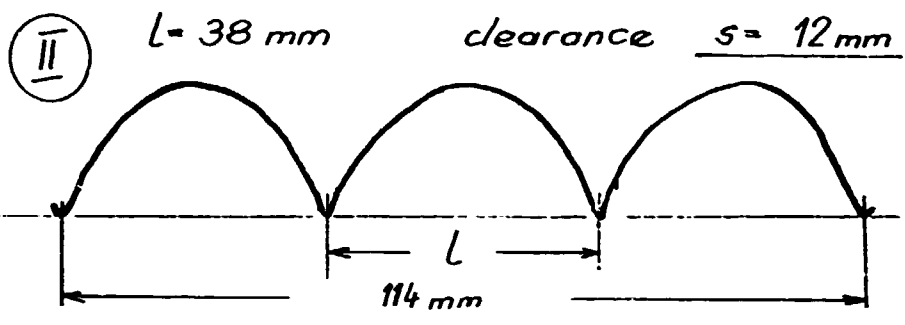
 $l = 41.6 \text{ mm}$ clearance $s = 13 \text{ mm}$ NOV. 6th 1992

③

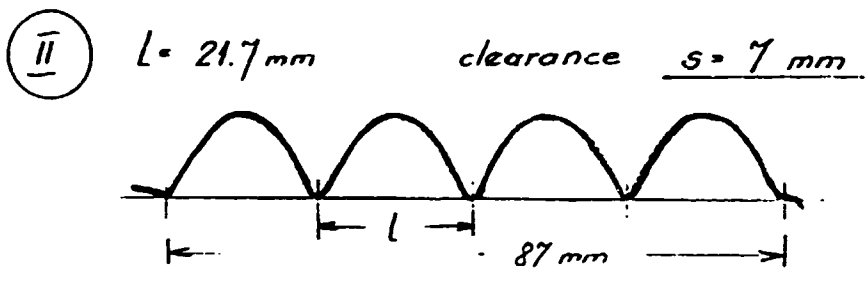
 $l = 38.6 \text{ mm}$ clearance $s = 12 \text{ mm}$ NOV 9th 1992

TYRE II

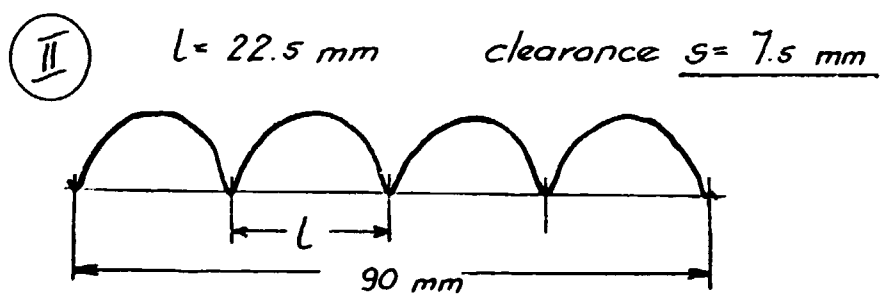
Measurement date:



← NOV 6th 1992



← NOV 9th 1992



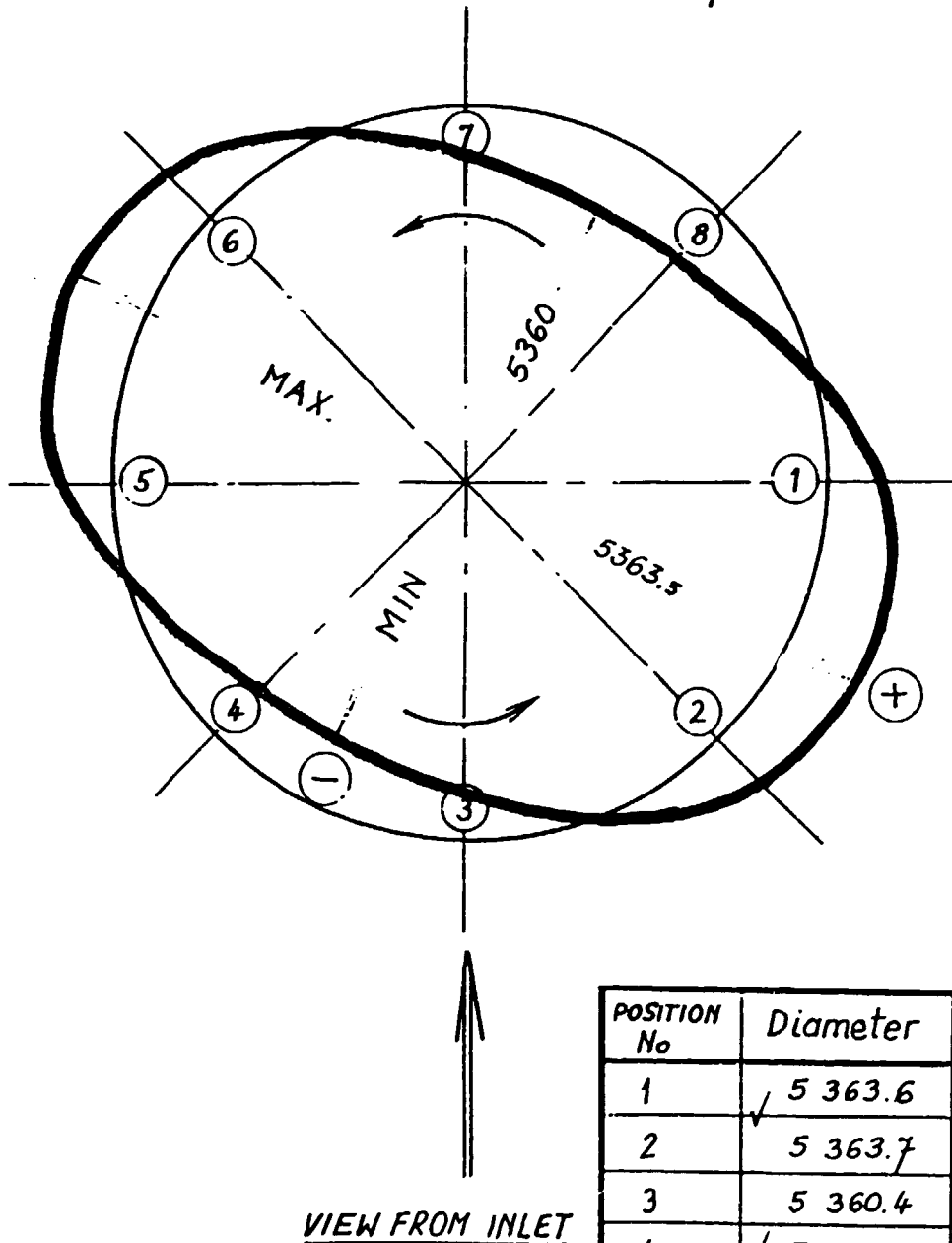
← NOV. 10th 1992
 NOV. 11th 1992
 NOV. 14th 1992
 NOV. 16th 1992

REAL UNDERTYRE CLEARANCE → 7.5 mm
FOR TYRE II

MEASUREMENT OF THE TYRE No 2 OVALITY

KILN No 2

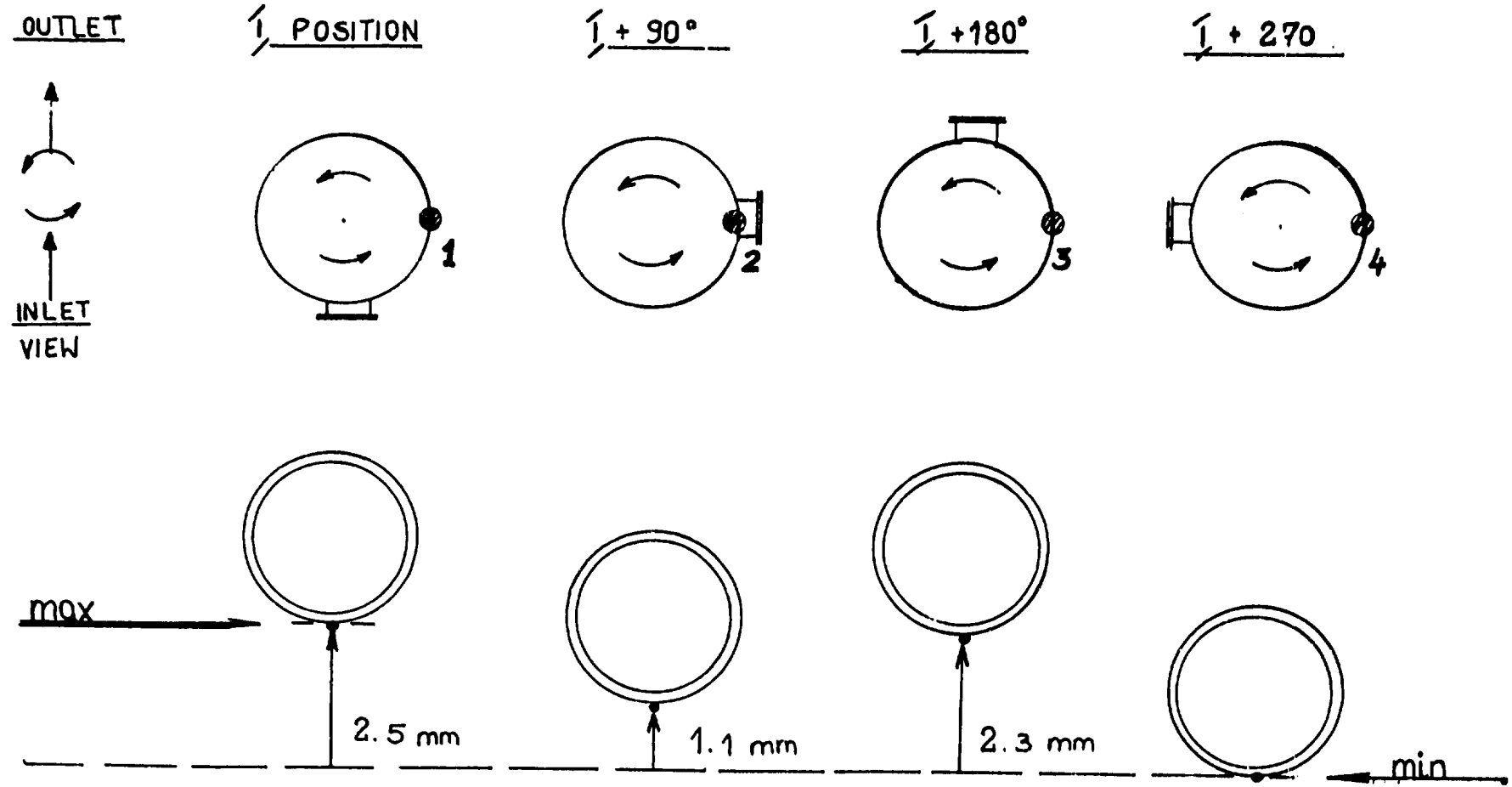
Average diameter 5362 mm



POSITION No	Diameter	Difference to average diameter
1	✓ 5 363.6	+ 1.7 mm
2	5 363.7	+ 1.8
3	5 360.4	- 1.5
4	✓ 5 360.0	- 1.9
5	5 363.6	+ 1.7
6	5 363.7	+ 1.8
7	5 360.4	- 1.5
8	5 360.0	- 1.9

average 5 361.9

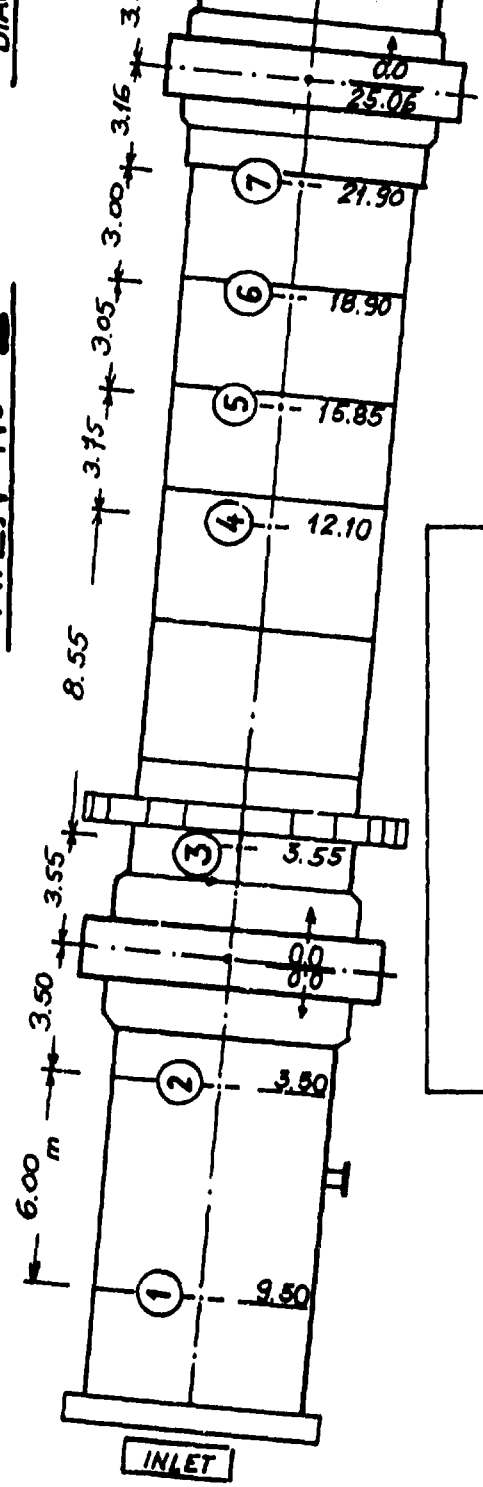
Diagram of the tyre's bottom height variation according to the Kiln position.



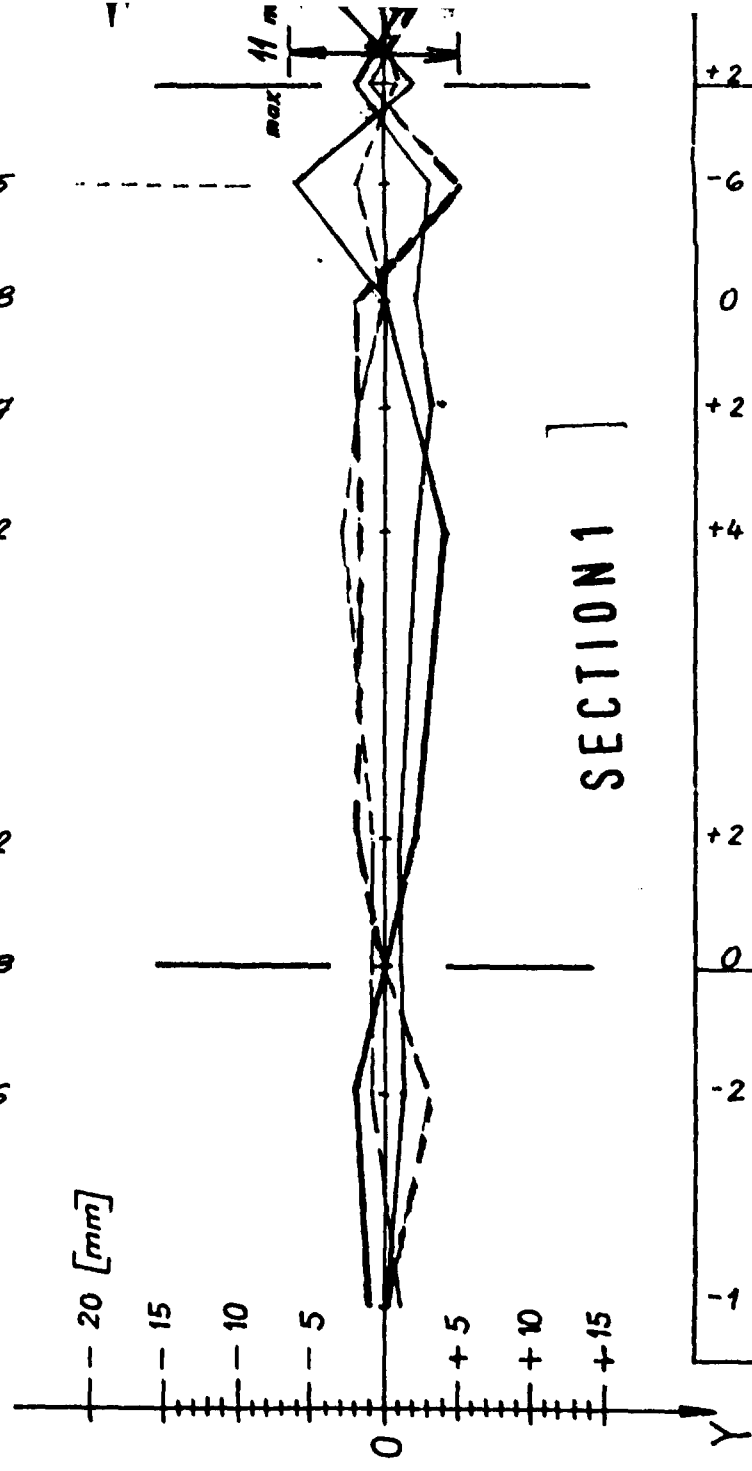
KILN No 2 - TYRE II

KILN No 2

DIA

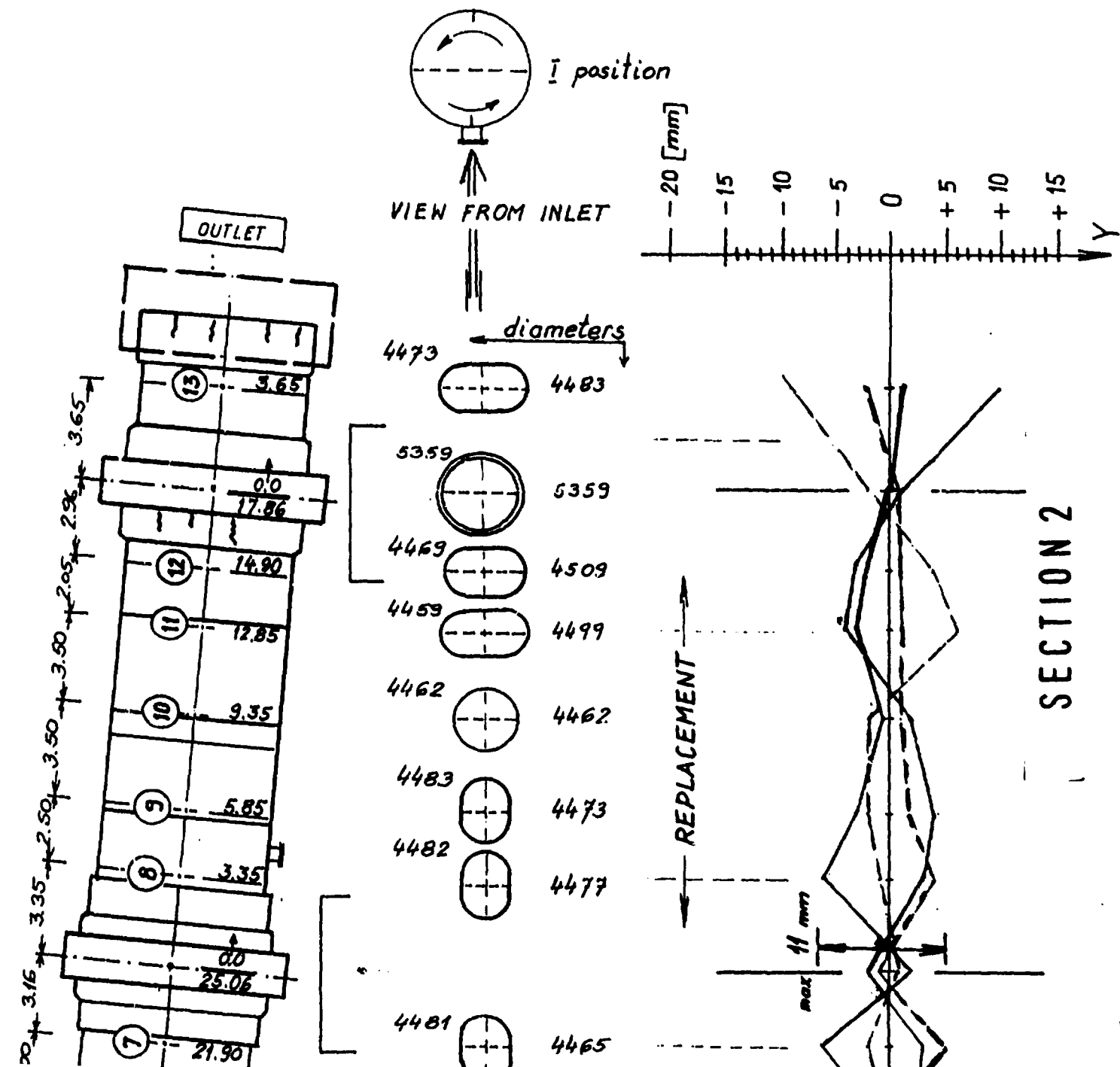


- 4481 4465
- 4479 4468
- 4453 4457
- 4461 4462
- 4472 4482
- 5358 5358
- 4477 4476
- 4460 4462



+2	-2	-1	+1
-6	+3	+5	-2
0	+2	-2	0
+2	+3	-2	-2
+4	+2	-2	-3
+2	+1	-2	-1
0	+1	0	-1
-2	+1	+3	-1
-1	0	0	+1

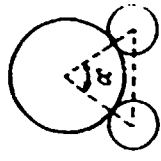
DIAGRAM OF THE KILN SHELL AXIS DEFORMATIONS



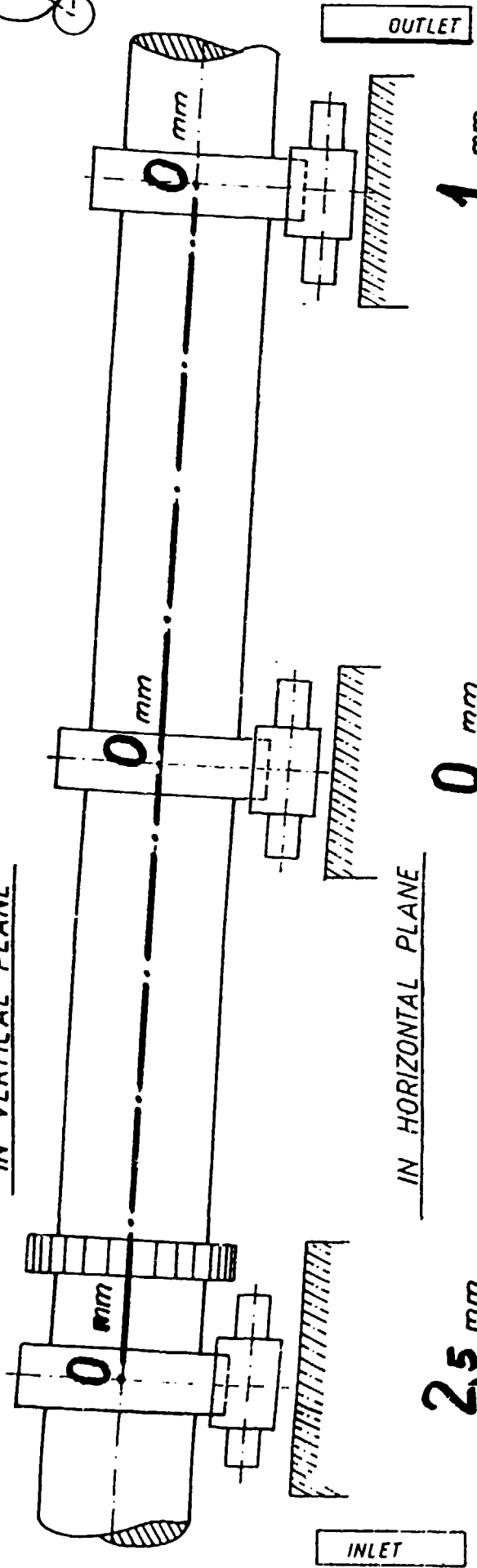
	<u>T position</u>	<u>T + 90°</u>	<u>T + 180°</u>	<u>T + 270°</u>
	+1	+10	-2	-9
	0	+1	+1	-2
	-2	-3	+1	+4
	-3	-4	+1	+6
	-1	+2	+1	-2
	-3	+4	+2	-2
	-6	+3	+4	-1
	+2	-2	-1	+1
	-6	+3	+5	-2

DIAGRAM OF AXIAL DEFORMATIONS AFTER ADJUSTMENT

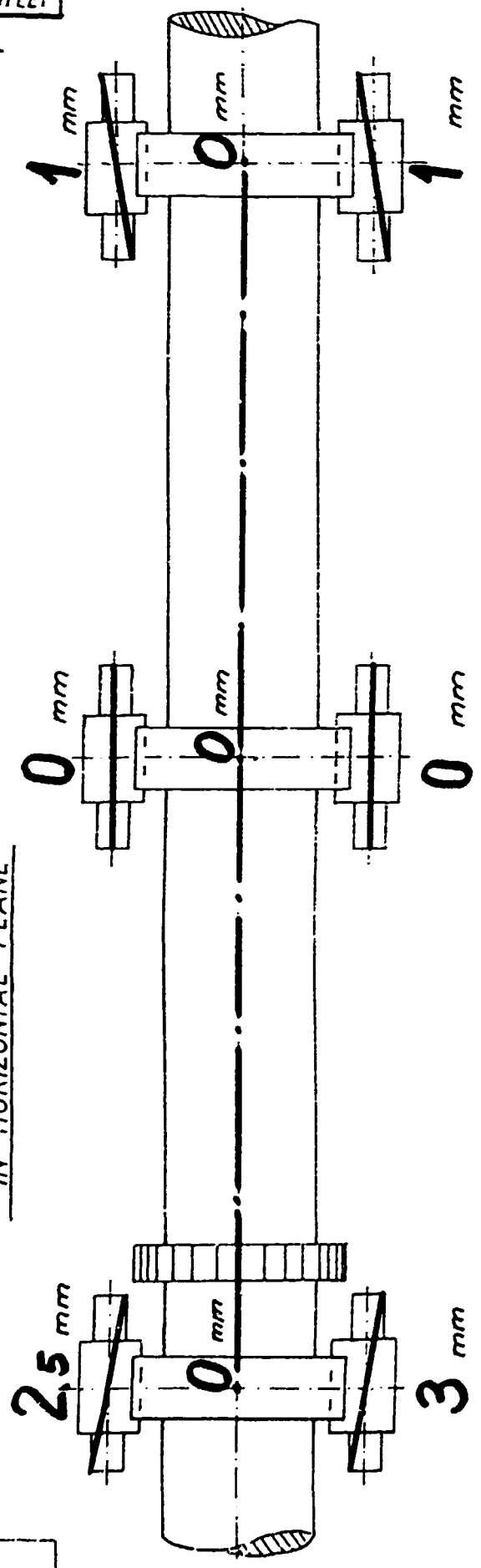
$\alpha = \dots 60^\circ 02'$ $\alpha = 60^\circ 07' \dots 1.5$ $\alpha = \dots 59^\circ 56'$



IN VERTICAL PLANE



IN HORIZONTAL PLANE





POLSERVICE

FOREIGN TRADE ENTERPRISE

Chałubińskiego 8
00-613 Warszawa
Poland

telefon 30-05-22
tlx 813539 upol pl
telefax 27-81-02

A P P E N D I X No 3

Hot kiln alignment

BY



GEOSERVEX
ENGINEERING MEASUREMENTS ENTERPRISE LTD

BYDGOSZCZ POLAND

kiln no. 3

BENGHAZI

The Libyan Cement Company

*The Industrial Complex
for Cement and Building Materials*

شركاء لا اجراء
Established on 1965 - 4 - 4



REPORT ON HOT KILN ALIGNMENT OF 2.500 TPD, DRY PROCESS,
3 SUPPORT KILN OF M/S THE LIBYAN CEMENT COMPANY,
BENGAZI-HAWARI , LIBYA.

Hot Kiln Alignment of the above kiln was carried out with the aid of Optico-Mechanical method, based on Patent authorised to Mr B. Krystowczyk (Ph.D.Engg).

1.0 SCOPE OF WORK

The scope of work includes following:

- 1.1 Measurement of kiln axis in horizontal and vertical planes during the kiln operation.
- 1.2 Measurement of support rollers axis in horizontal and vertical planes.
- 1.3 Measurement of undertyre clearance by means of differential method during the kiln operation.
- 1.4 Calculation of the deviation of the actual kiln axis from optimal axis in horizontal and vertical planes by a computer programme.
- 1.5 Calculation of rollers torsion and the adjustment required.
- 1.6 Working out the schedule for rollers adjustment with the participation of LCC's representatives.
- 1.7 Checking measurements after the adjustment.

3.0 Measurements were carried out by representatives of BUDEXPOL-POLSERVICE from 21st to 25th of Nov. 1992

3.1 The results of our measurements are as below:

3.2 The deviations of Kiln axes are as below:(refer page No 4)

Support No (from inlet end)	in vertical plane (mm)	in horizontal plane (mm)
1	0.0	0.0
2	6.0	2.0
3	0.0	0.0

The Kiln axes in vertical and horizontal planes require adjustment which is shown on page No 6.

3.3 The support roller axis torsions in vertical plane were found within the tolerance (refer page No 5) However, torsions in horizontal plane require some regulations which are shown on page No 7.

3.4 The rollers working angles are within the tolerance which for this type of Kiln should be $60^{\circ} \pm 1^{\circ} 30'$ (refer page No 4)

Support No	Angle
1	$59^{\circ} 47'$
2	$59^{\circ} 45'$
3	$59^{\circ} 50'$

3.5 The Kiln's inclination is accurately at 3.00%

3.6 The results of undertyre clearance are as below:

(refer page No 4)

Tyre No	<u>Undertyre clearance</u>
1	5 mm
2	10 mm
3	15 mm

We recommend to reduce the undertyre clearances on 2nd and 3rd supports by inserting undertyre shims. (thickness of shims shows page No 6).

However, this regulation is not as important as Kiln axes adjustment which is recommended to be carried out as soon as possible.

In this particular case inserting undertyre shims will not change a vertical Kiln axis and can be done at a later time.(During a long Kiln stoppage)

3.7 Improper rollers torsions in horizontal plane keep the Kiln in its upper position.

Besides, these torsions make the Kiln's floating impossible to achieve, because of improper thrust rollers performance.(Rollers torsions regulation is shown on page7)

3.8 We would also like to point out that considerable Kiln axis deformations are slowly breaking off the Kiln's shell on 2nd support and have a big influence on all lining problems.

All steps of above mentioned adjustment shows page No 9.

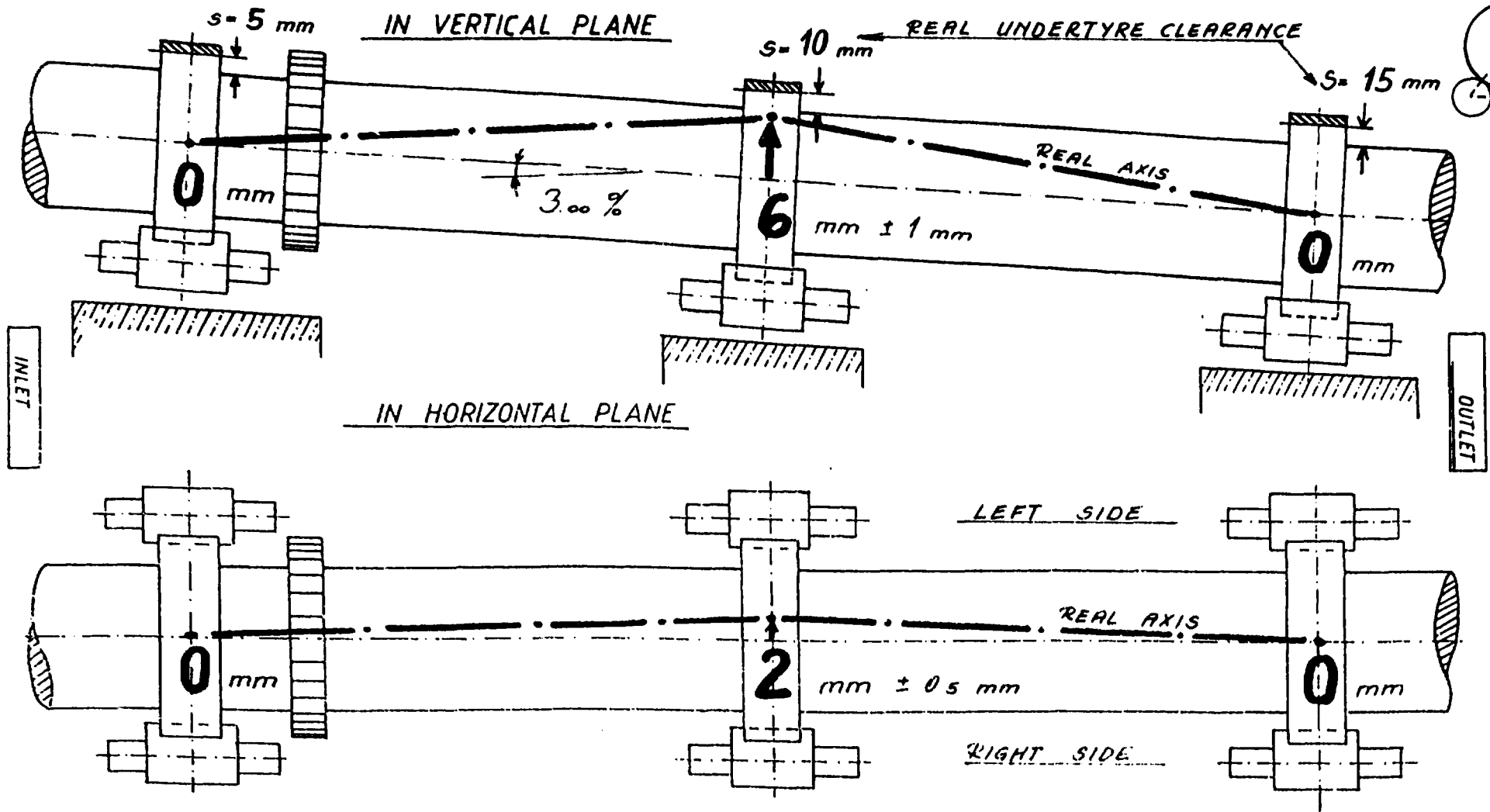
For BUDEXPOL - POLSERVICE

Engg. Wiesław PAUSZEK(M.Sc.)



DIAGRAM OF AXIAL DEFORMATIONS

$\alpha = 59^\circ 47'$ $\alpha = 59^\circ 45' \pm 5'$ $\alpha = 59^\circ 50'$



THE WILSONS COMPANY
The Industrial Complex
for Cement and Building Materials

Established in 1948 - 4 - 4

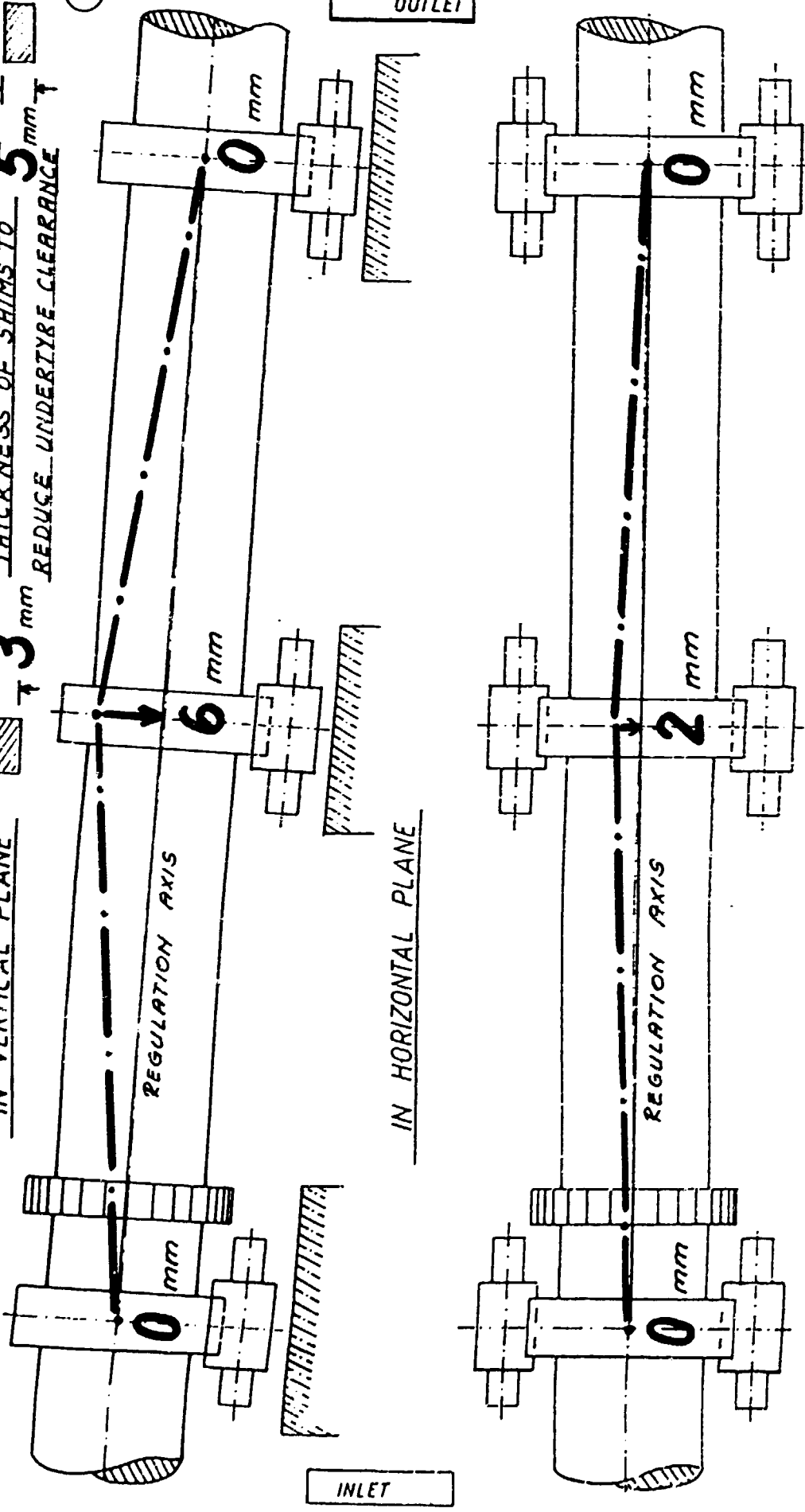
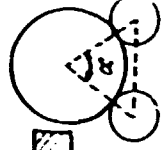
DIAGRAM OF AXIAL DEFORMATIONS - FOR REGULATION

$\alpha = 59^{\circ} 47'$ $\alpha = 60^{\circ} 10' \pm 5'$ $\alpha = 59^{\circ} 50'$

IN VERTICAL PLANE

3 mm

THICKNESS OF SHIMS TO
REDUCE UNDERTYRE CLEARANCE
5 mm

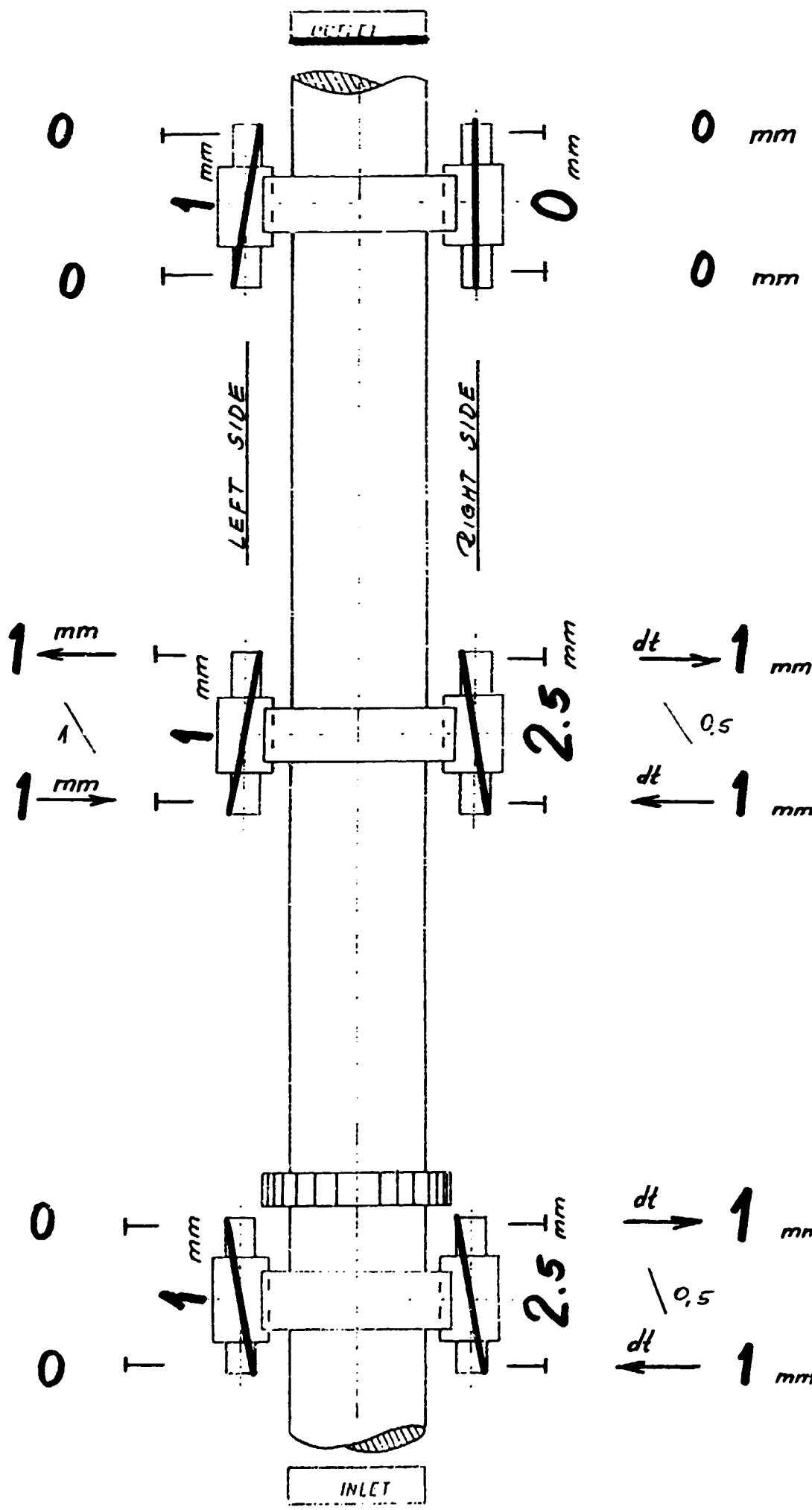


شركة ليبيان
Established in 1965

The Libyan Cement Company

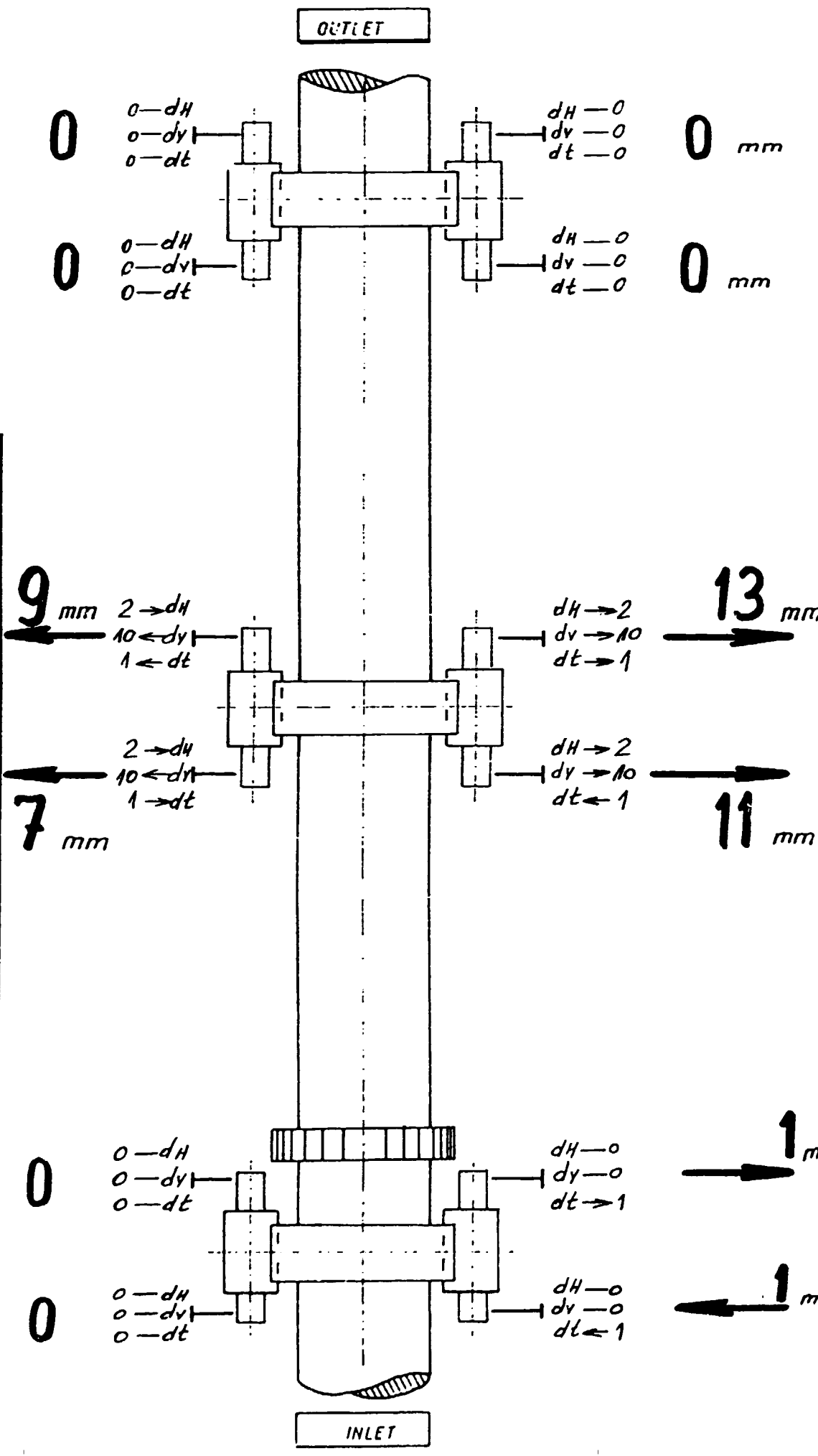
The Industrial Complex
for Cement and Building Materials

SCHEDULE FOR ROLLERS AXIS TORSION ADJUSTMENTS



شركة
 الليبية
 Established on 1963
The Libyan Cement Company
 The Industrial Complex
 for Cement and Building Materials

SCHEDULE FOR REGULATION ADJUSTMENTS

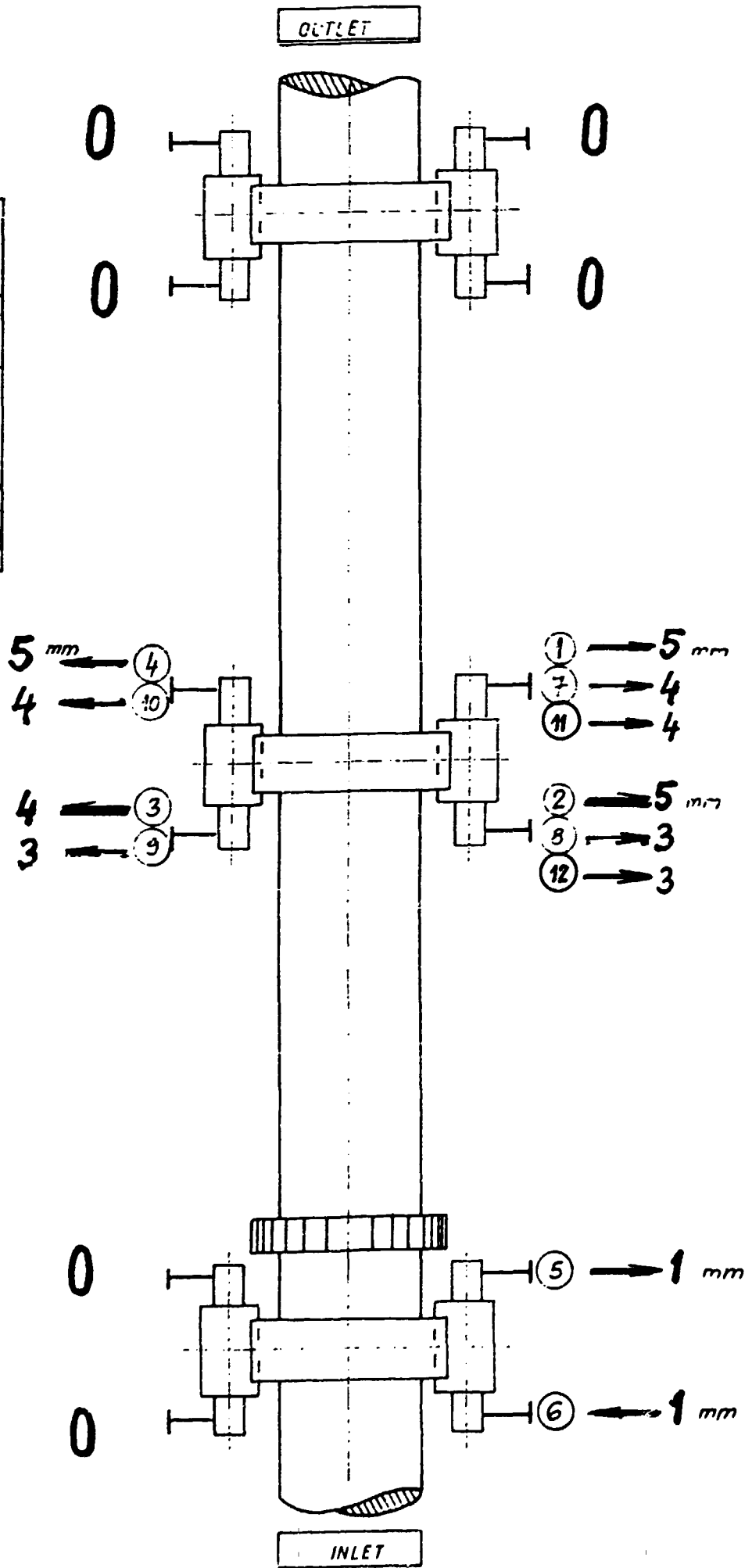


سبرشاء لا اجراء
Established on 1965.4.4

The Libyan Cement Company
The Industrial Complex
for Cement and Building Materials

SCHEDULE FOR REGULATION ADJUSTMENTS

STEP BY STEP



1-6 O red colour — 1st day adjustment
7-9 O green colour — 2nd day
11-12 O black colour — 3rd day



GEOSERVEX
ENGINEERING MEASUREMENTS
ENTERPRISE LTD

6. SEROCKA STREET
85-552 BYDGOSZCZ
POLAND

PHONE: (48-52) 271-691
211-428
TELEX: 0562787 PL
FAX: 271-691

A P P E N D I X N o 4

Hot kiln alignment

Author :
Bolesław Krystowczyk PH.D.Eng.

1991.10.04

CONTENTS

	page
1. Introduction	1 - 2
2. Problems and peculiar characteristics of rotary kiln deformation measurements	2 - 7
3. Description of rotary kiln deformation measurements and corrections calculation	
3.1. Survey results presentation	7 - 9
3.2. Corrections calculation	9 - 11
3.3. Adjustment of horizontal torsions of rollers axis	11 - 13
4. Adjustment rules - rollers shifting	13 - 14
5. Kiln operation while adjusting	14 - 15
6. Adjustment disturbances	
6.1. Bearings temperature rise	15 - 18
6.2. Axial shift	18
6.3. Change in adjustment variant	19
6.4. Increase in motor power consumption	19
7. Final comments	19 - 20
8. Bibliography	21

Introduction

One of basic conditions of reliable operation of the rotary kiln is to maintain the ideal geometry during the kiln rotation, namely:

- a/ the rectilinearity of the kiln axis in horizontal and vertical plane
- b/ proper horizontal and vertical torsions of roller axis
- c/ roller's working angles $\alpha = 60^\circ$
- d/ kiln drive teeth contact
- e/ kiln axis slope
- f/ under-tyre clearances

The hot kiln alignment is the process of measurement and adjustment aiming at meeting the above said geometrical conditions imposed by the kiln manufacturer or the kiln operation conditions as the sum of experience of the manufacturer and the rotary kilns users.

The alignment is to result in optimum setting of the kiln geometry and rollers to attain the best productivity of the kiln.

After a certain time of operation the kiln undergoes deformations due to the temperatures changes /axial and tyre elongation/ in result of foundations settlement and the rotary motion impact /vibrations, cyclic displacement of supports/ as well as usual wear and tear and all these factors cause the necessity of alignment process.

Apart from the above said reasons of the kiln deformations, which are beyond the human control, there are deformations caused by the assembly defects, post-overhaul assembly defects as well as servicing mistakes. Experiences gained during the alignment process of various rotary kilns operating in many countries lead to the opinion that the kiln alignment should take place periodically during the operation;

The first alignment should be carried out immediately after the new kiln start-up and when the production parameters are fully attained and then the further alignment process should be repeated each time after the overhaul, when rollers or other kiln parts were replaced, but not less than once a year.

As a rule, the alignment process consists of two necessary and integral stages:

- a/ measurements of kiln geometry deformation and calculation of corrections
- b/ introduction of corrections through the rollers shifting

In this paper, problems concerning measurements of deformation shall be touched within the small range considering the fact that the measurements are complicated and require special equipment and specialized personnel.

Assuming that each kiln is measured once a year on an average, there is not necessary the cement-plant staff training but the users should be instructed how to take advantage of the results of measurements. This paper is to present gained experience concerning the methods of alignment, evaluation of kiln operation during the alignment process, presentation of corrections calculation for various types of alignment as well as the assistance in case necessary precautions have to be taken during the process /roller pivot overheating, axial shift etc./

Acquired knowledge shall allow to take advantage of the measurements results and to solve some problems between sequent alignment processes.

2. Problems and peculiar characteristics of rotary kiln deformation measurements

The correctness of alignment depends, to a large extent, on the method of measurements carrying out.

At present the "hot kiln alignment" becomes the world

standard method /1/ /2/ /3/.

So far, the alignment process took place on the basis of survey made with geodesy methods at cold kiln or the SHELLTEST device information on deformations. The SHELLTEST results inform about the kiln shell ovalization but data necessary for particular rollers adjustment are not obtainable.

The SHELLTEST results concerning the kiln axially are approximate and ineffective ones, and moreover, no information necessary for adjustment of roller axis torsion, roller working angle, kiln axis and rollers inclination, adjustment of axial shift has been received from shelltest.

This method has been criticised in the published paper /3/.

The second widely applied method of alignment based on results of cold kiln geodesy survey deserves more details.

There is assumed that the survey was made during the kiln standstill, rollers had been shifted and the ideal cold kiln alignment was reached.

It is generally known that dimensions of the kiln have changed during the operation and particular constructional elements have been displaced due to the temperature influence and the kiln operation conditions. In order to illustrate the character and the range of changes there are presented results of survey of rotary kiln with dimensions $\phi 5.6 \times 160m$.

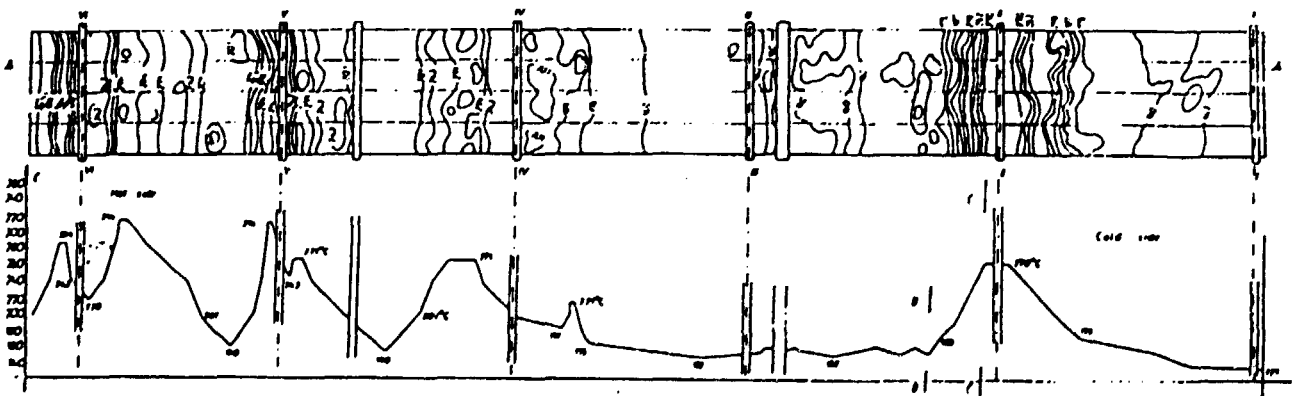


Fig. 1

Figure No. 1 presents the map of temperatures and the profile of temperature ranges of the examined kiln shell /the examination was carried out with thermo-vision camera AGA-680/ on which the temperatures distribution on the kiln shell is different and does not stick to the theoretical distribution and to that of newly-assembled kiln.

In table No.1, on the basis of fig. No. 1 are presented elongations of particular segments of drum in relation to the same section of drum during the kiln standstill. There are also figures defining changes of tires position in relation to the kiln center point.

Support No	Kiln section length while standstill (mm)	Kiln section length while running (mm)	Elongation Δl (mm)	Elongation in relation to kiln center point ΔL
I				155
II	31070	31084	64	91
III	30640	30703	63	+78
IV	28670	28677	57	-100
V	28570	28642	72	-79
VI	24530	24597	67	-158

Table No. 1

If the roller axis is parallel to the kiln axis and if it is truly cylindrical in shape / fig. 2.1 / the deformations of kiln axis Δ_z would not occur due to the change of Δ_l tire position on the roller /this situation occurs in new kilns which are correctly assembled/

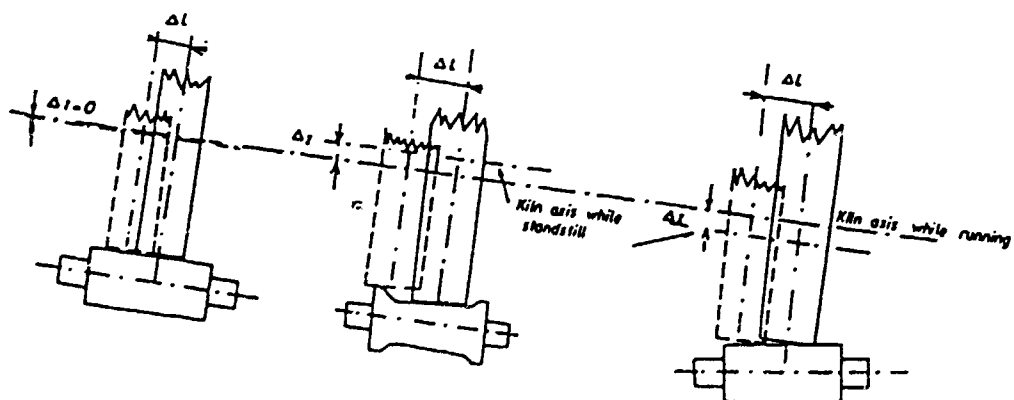


Fig. 2.1

Fig. 2.2

Fig. 2.3

After a certain period of operation the running surfaces of rollers are as shown on figure 2.2.. and a few or a dozen millimeters of the central part is worn. Under these circumstances the deformation Δ_z vertical axis of kiln after its start-up shall be a dozen millimetres according to the rollers wear-out degree as it is presented on fig. 2.2

Also the roller axis inclination out-of-parallel to the kiln axis shall cause the deformation Δ_z of the kiln axis / fig. 2.3 /

In most cases, both reasons of vertical axis deformation due to axial elongation appear together and cause non-alignment of kiln during its operation; this non-alignment exceeds the maximum permissible tolerances /3 + 5 mm/

In result of variable temperature the tire and drum diameters change accordingly / fig. 3 /

Support №	Diameter while standstill [mm]	Diameter while in operation [mm]	Difference [mm]
1	6001,0	6003,6	+2,6
2	5997,1	6000,6	+3,5
3	6001,6	6007,8	+6,2
4	6001,0	6007,1	+6,1
5	6125	6195,9	+70,9
6	6007,0	6010,9	+3,9
		Measurement accuracy	±1mm

Table No. 2

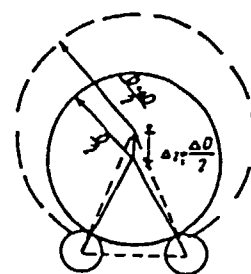


Fig. 3

Considering the fact that the temperature rise is not the same or proportional for all tires / fig. 1 / this is another reason of deformation Δ_z

In table No.2 are specified diameters of tires of examined rotary kiln measured during the kiln standstill and during the operation.

One can see that the diameters growth is different and out-of-proportion to temperatures distribution /fig. 1, but differences in diameters are very important for correct alignment of the kiln.

Some of conditions of the kiln operation can cause considerable distortion of measurements results at the same time destroying the efficiency of the alignment process.

The rotary motion of non-aligned kiln causes vibrations and cyclic deflections of the upper parts of piers and the kiln axis as well.

The amplitude of deflections in some cases attained 10-30 mm.

This concerns especially 3-pier kilns with long diameters of drum where relatively small deflections caused resonance and devastation of kiln refractory lining more frequent than in normal conditions and considerable economic losses are unavoidable.

Basing on the carried out measurements there was stated that geometrical axis of drum has various position in given situations and this results from local stresses as per the presented fig. 4.

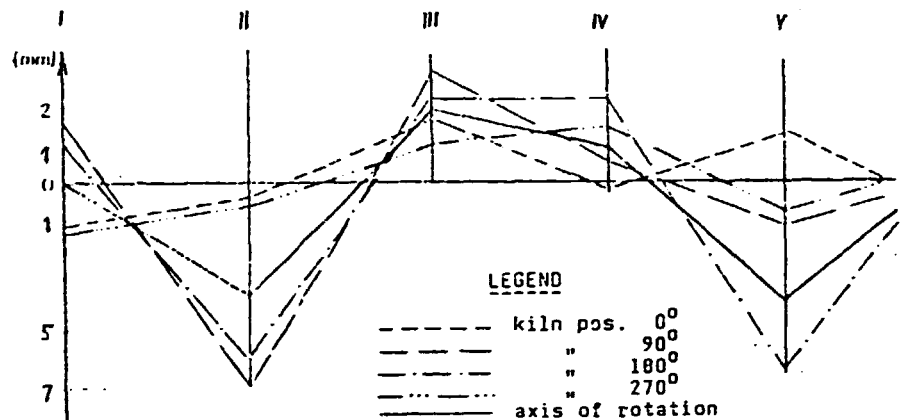


Fig. 4

So, if the measurement is made in defined static condition of kiln, even though the kiln should be turned by 90°, the indicated geometrical axis can be different from the axis of the kiln rotation known from measurements taken during the kiln operation. The above specified dynamic conditions of the kiln operation have their impact in common and cause deformation of the kiln axis after the start-up. Figure No. 5 shows results of 2 measurements of the same kiln, one taken before and another one taken after the start-up and when the normal operation parameters have been attained.

The differences that were found exceed several times admissible limits of kiln axis rectilinearity deviation.

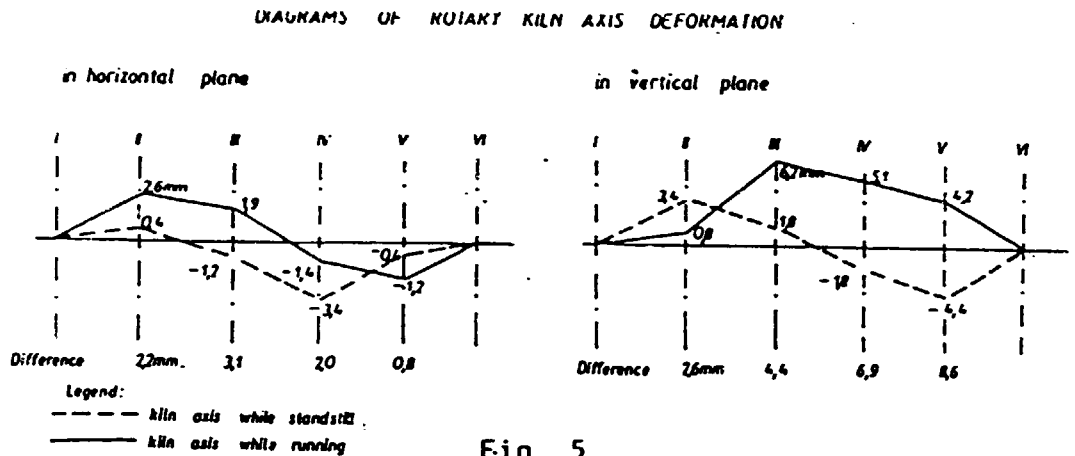


Fig. 5

As results from the above said the kiln alignment during the standstill does not provide its rectilinearity during the operation, because even the most accurate measurement taken during the standstill defines different position of the kiln parts in relation to these parts position during the operation.

3. Description of rotary kiln deformation measurements and corrections calculation

3.1. The survey results presentation

Figure 6 shows the results of measurements of rotary kiln of Messrs UBE /Japan/ installed in ... obtained through hot kiln alignment method.

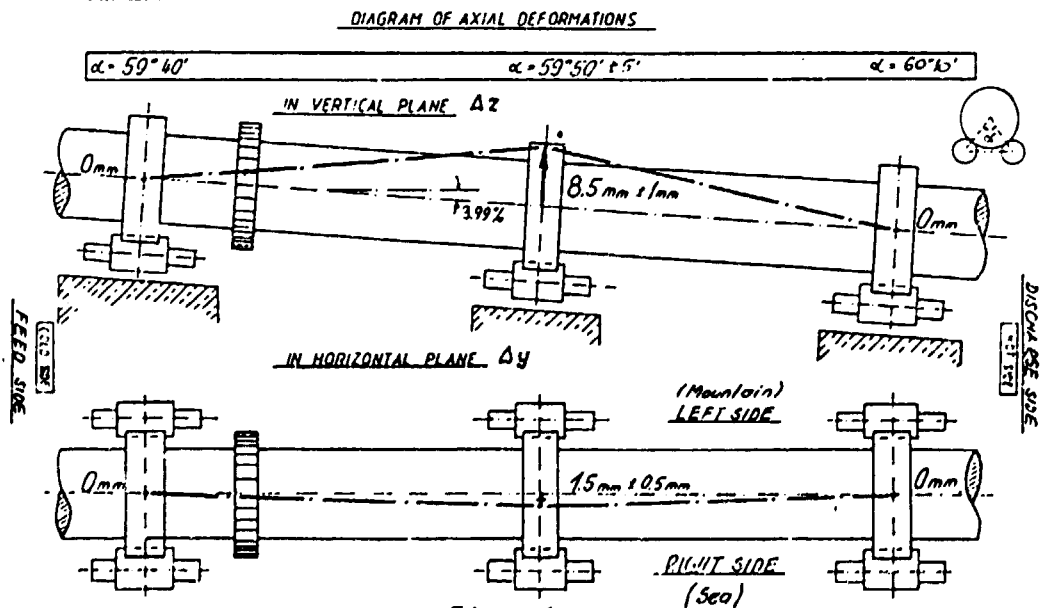


Fig. 6

The kiln axis deformations are shown in both planes: horizontal Δ_y and the vertical Δ_z .

Deformations are presented in relation to straight line connecting axial points of the kiln shell and placed in planes going through the center of width of the first and the last tire.

Horizontal deformations " Δ_y " of the shell axis and the axis of tires set are the same, however vertical deformations " Δ_z " of the shell axis in the places of supporting and vertical deformations of tires set axis are different because of under-tyre clearances Fig. 7

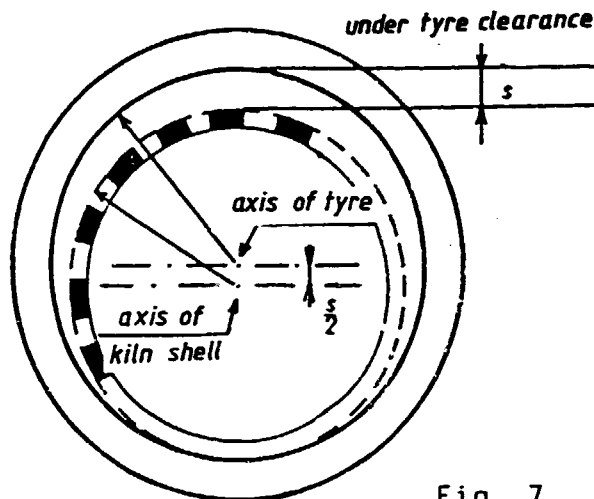


Fig. 7

If the under-tyre clearances "S" measured during the kiln operation are of the optimum value $3+6$ mm, the kiln alignment can be identified with tires set alignment.

The values of under-tyre clearances are presented as the measured parameters of kiln geometry.

Figure 6 presents roller axis torsions:

horizontal projection of horizontal torsions of roller axis /at horizontal deformation Δ_y / and vertical torsions on vertical section.

Roller axis torsions are shown in relation to the kiln axis.

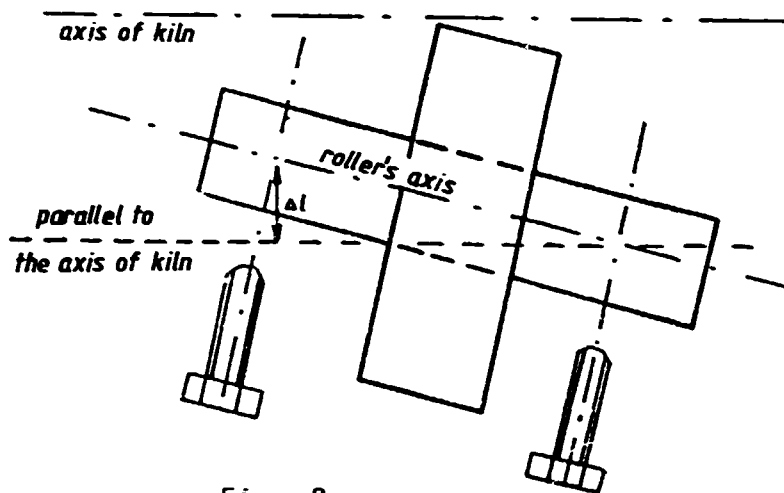


Fig. 8

Roller axis torsions are not in angular measure but in linear measure /in millimetres/

Horizontal torsions stand for the distance Δ_L shown on fig. 8

- out-of-parallel roller axis in relation to the kiln axis along the length of axis between adjusting screws.

Vertical torsions, in most cases, are shown as the out-of-parallel roller axis in relation to the kiln axis measured along the whole length of the roller pivot /between centre holes/

3.2. Corrections calculation

On the basis of measurements results /fig. 6/ we can calculate corrections of rollers shifting.

Horizontal deformations Δ_y are removable by shifting both rollers to the same direction and by the value $dy = \Delta_y$, but the vertical deformations Δ_z are removable owing to approaching or moving away to different directions both rollers by the value of $dz = \sqrt{3} \cdot \Delta_z$

In case of the decision that the kilns axis after the adjustment /adjustment axis/ should go through the axis points of tire at the kiln inlet and outlet the left roller on the central support should be pushed outside /outside of kiln/ by 16 mm and right roller should be pushed outside of the kiln by 13 mm.

- In most cases the alignment process is carried out at the additional geometric conditions concerning:
- changing or leaving in the same position the toothed wheel rim and pinions
 - leaving in the same position or shifting inlet and outlet points of the kiln shell in relation to the kiln heads
 - leaving the same position of axis on selected support as "constans"

The straight line connecting two points that meet additional requirements of cooperating parts is called the adjustment axis.

If there is more conditions than two the adjustment axis should be centered or the one of conditions should be abandoned /solved with another method/.

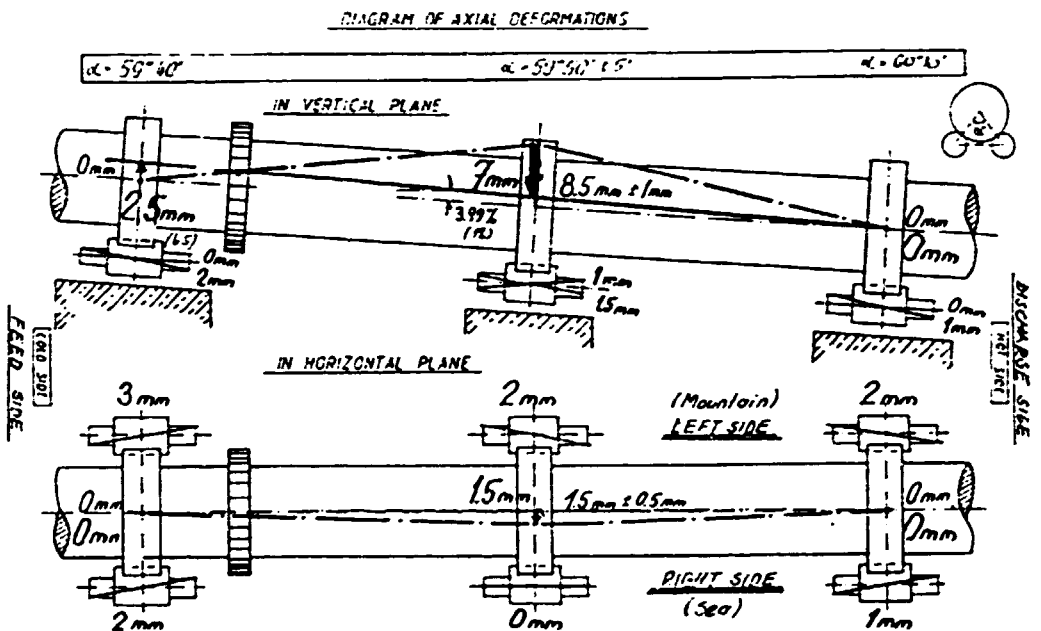


Fig. 9

The alignment/adjustment of kiln presented on fig. 6 has been carried out at the condition of unchanged contact with pinions

The plan of adjustment is shown on fig. 9. Deformations Δ_y and Δ_z has been replaced by movement vectors Δ'_y and Δ'_z in relation to the adjustment axis.

Figure No.10 presents the method of calculation of support roller due to vertical and horizontal "dy" and "dz" shifting and due to roller axis torsions in horizontal plane "dl" /the problem of torsions adjustment shall be the subject of next chapter/

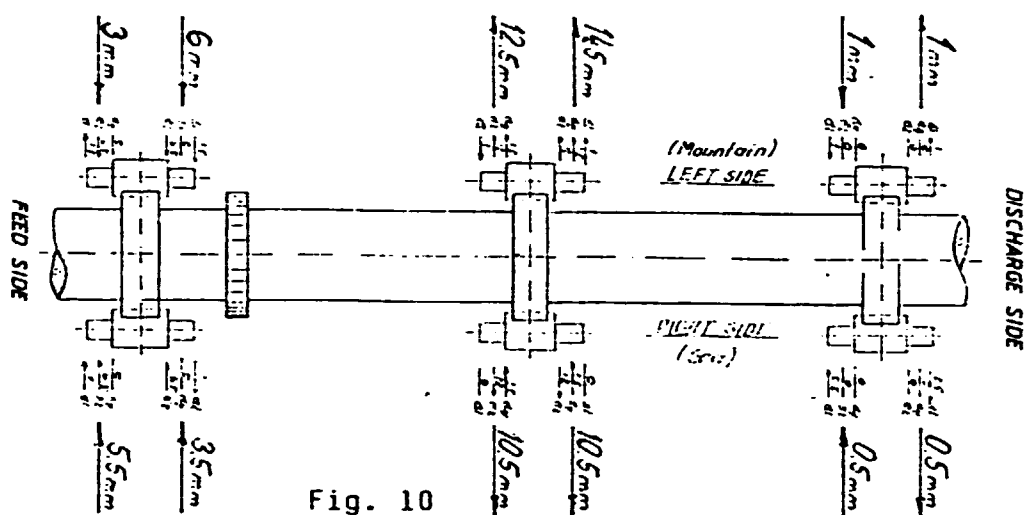


Fig. 10

3.3. Adjustment of horizontal torsions of roller's axis

The rotary kilns with hydraulic adjustment of axial shift should be equipped with rollers parallel to the kiln axis.

The majority of kilns has no hydraulic adjustment and the axial shift is controlled by rollers torsions /axial force starting/

Axial force depends on direction of kiln rotation and on the direction of roller torsion - those dependences are shown on scheme /fig. 11/

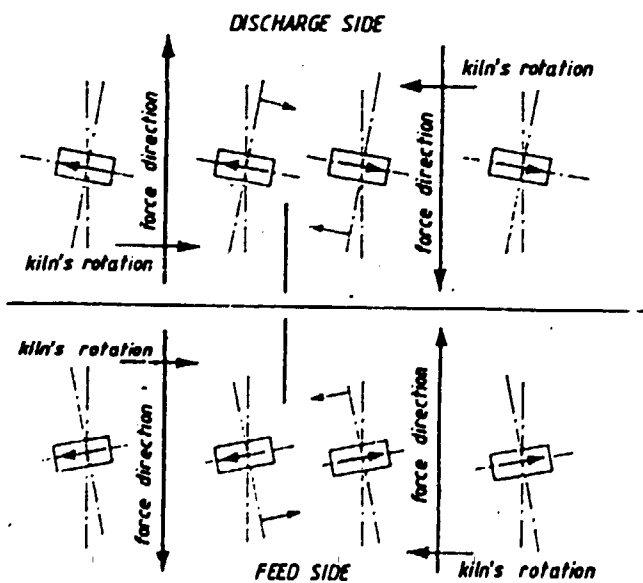


Fig. 11

There are various theories concerning rollers' torsion adjustment two of them, the most recognized ones are worth presenting:

- minimal torsions of all rollers pulling the kiln to the inlet side and equilibrating gravitational axial slide down
- positioning roller torsions in burning zone as in the neutral position remaining rollers as per the first method.

Figure No.12 shows rollers' torsions of Messrs "ALLIS CHALMERS" kiln.

Rollers' torsions on the right side of kiln are correctly oriented /kiln is pulled up/ but the half of rollers on the right side pushes down.

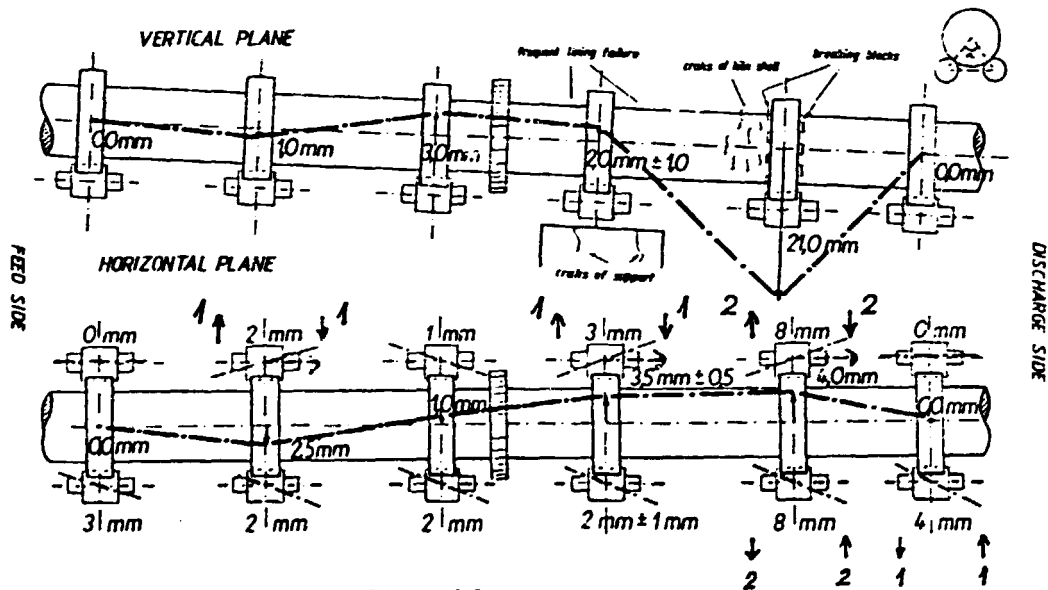


Fig. 12

Of course, the axial force coming from rollers pulling kiln in improper direction has to be equilibrated by pulling up rollers' torsions bigger than needed ones. The torsions of half of rollers on the right side, through correct in orientation are incorrect by starting various axial forces /roller on the second support "pulls" 4 times more than rollers on supports 3,4,5.

This causes considerable wear of the roller and tire surfaces, overheated pivots, increased power consumption of motors, broken thrust blocks at the tires, worn-out plates between tires and the kiln shell etc. Rollers' torsions corrections have been shown on fig. 12.

Optimum torsions of rollers of the kiln agreed during the adjustment: 2 mm

The correct plan of adjustment of torsions could be made out basing exclusively on the measurements, but the decision is made according to the results of:

- visual inspection of tires parts cooperating with rollers
- visual inspection of rollers pivots position cooperating with thrust bearings

The rollers' wear-out degree should be additionally taken into consideration /shape of roller/ as well as the influence of rollers axis torsions

4. Adjustment rules - rollers shifting

Figure 13 shows the programme of adjustment process with specified sequent actions.

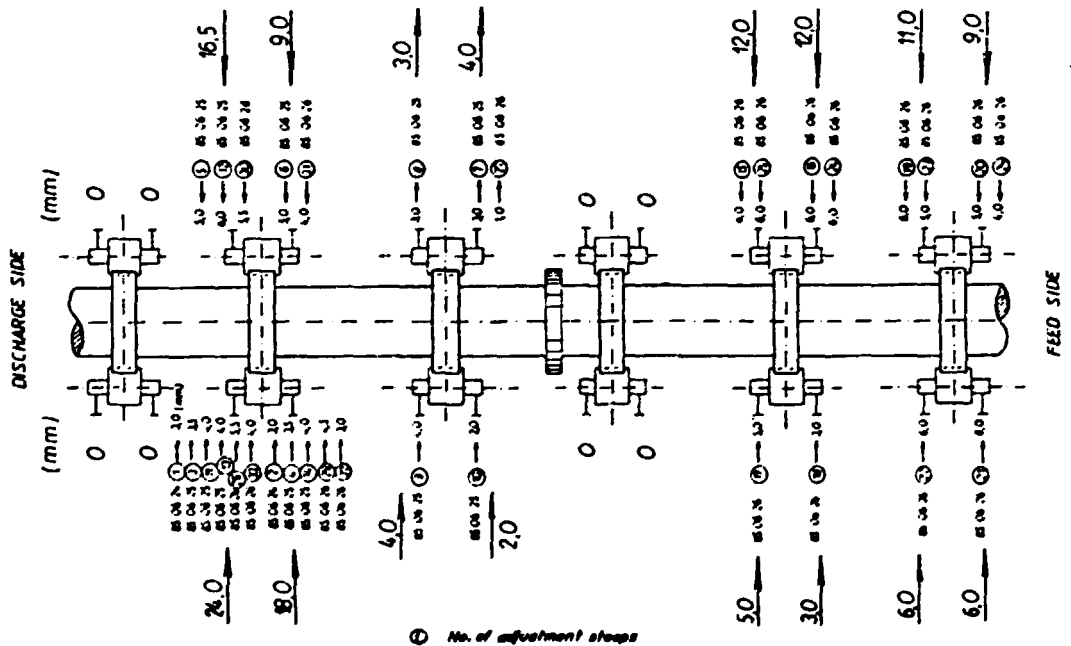


Fig. 13

Rules of adjustment are as follows:

- a/ one shift of roller should not be longer than 5 mm /next shift after 12 + 24 hrs/
- b/ both ends of the roller /e.g. action "1" and "2" "3" and "4" etc./ should be shifted in parallel position, if possible
- c/ If the equipment possibilities makes the above condition impossible there is necessary
 - to shift the roller's ends in minimum intervals
 - to start shifting from the roller's end which provoke axis force pulling the kiln "down"
- d/ at first, rollers which need the most adjustment corrections /including subsection "a"/ should be shifted
- e/ the adjustment causing changes in rollers' torsions should be carried out after the rough alignment of kiln /50 + 60% of corrections/
- f/ torsions which pull "down" the kiln should be removed
- g/ the sum of kiln axial forces should be zero after the rollers adjustment.
- h/ big torsions should be decreased and small torsions should be increased

5. Kiln operation while adjusting

While adjusting the kiln, both the cooperating parts and the kiln itself should undergo the observation. The following stages are to be observed:

- a/ axial shift, toothed wheel rim and points of the kiln contact with heads at the inlet and outlet
- b/ motor power consumption
 - /increase in power consumption in the first period of adjustment up to 15% is considered as normal phenomenon which retreats after 3+5 days/
- c/ temperature of rollers' pivots /momentary increase in pivots temperature is normal/

d/ axial changes of tires position and changes in rollers pivots position in relation to slide bearings

e/ vibrations on particular piers of roller

f/ technical condition of rollers, rings, kiln shell, under-tyre washers/pillows/

keen observation of technical condition of kiln and rollers before the adjustment would be much-desired because any crack or deformation etc. which was not found or notified before adjustment should burden the alignment.

6. Adjustment disturbances

6.1. Bearings temperature rise

The most important problem during the adjustment is the slide bearings temperatures increase.

This phenomena which is not corrected in time could lead to the bearing seizing. This problem causes the mechanics forbearing from any adjustment in fear of problems with temperatures of bearings. Good knowledge of adjustment rules allows for safe shifting the rollers and remove the increase of bearings temperature through the appropriate correctio shifting.

As it is known from practice and experience bearings are overheated due to axial forces impact.

In order to understand some phenomena it is indispensable to make acquaintance with bearings structure,

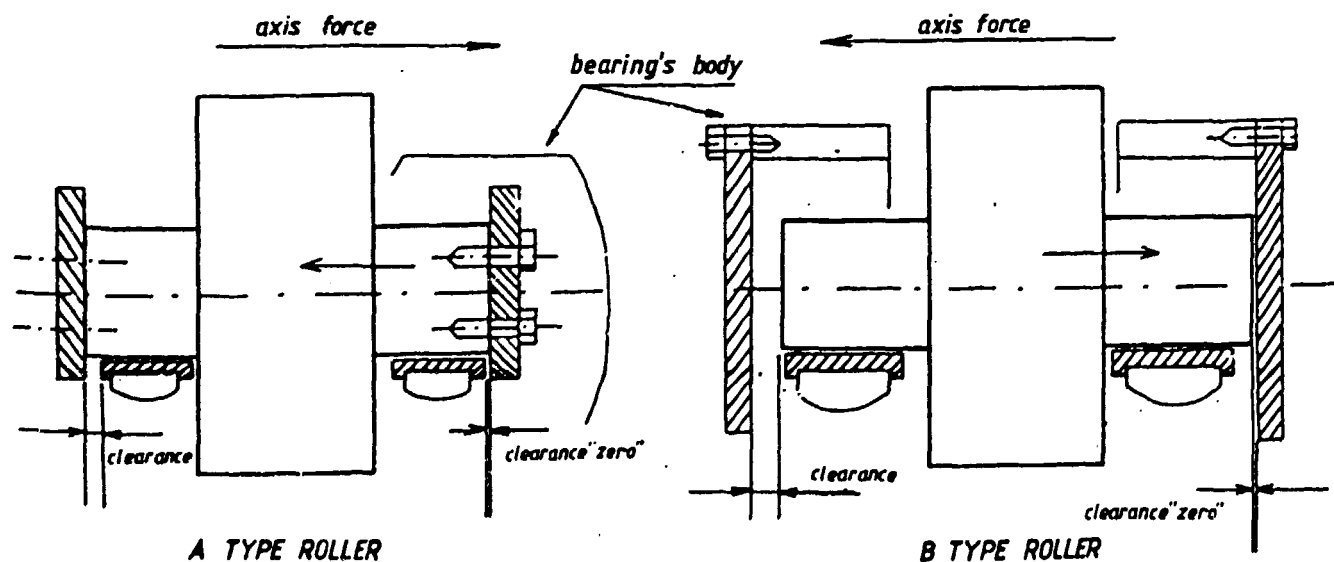


Fig. 14

Figure No.14 . presents two methods /mostly applied type "A" and type "B"/ of limitation of roller pivot axialshift. The roller position is defined regarding clearances /fig. 14/ - where the clearance is "zero" there is a friction causing the bearing temperature rise. If the axial forces generated by roller axis torsions are excessive ones, the immediate temperature rise is registered in the pivot shift limitation place and then are coming down: reduced oil viscosity, rise in temperature of further parts of pivot, rise in temperature of bearing bush and the bearing seizing.

There are situations that occur during the kiln operation /not necessary during the adjustment/, therefore the detailed examination and evaluation of behaviour of mechanics facing this problem would be advisable.

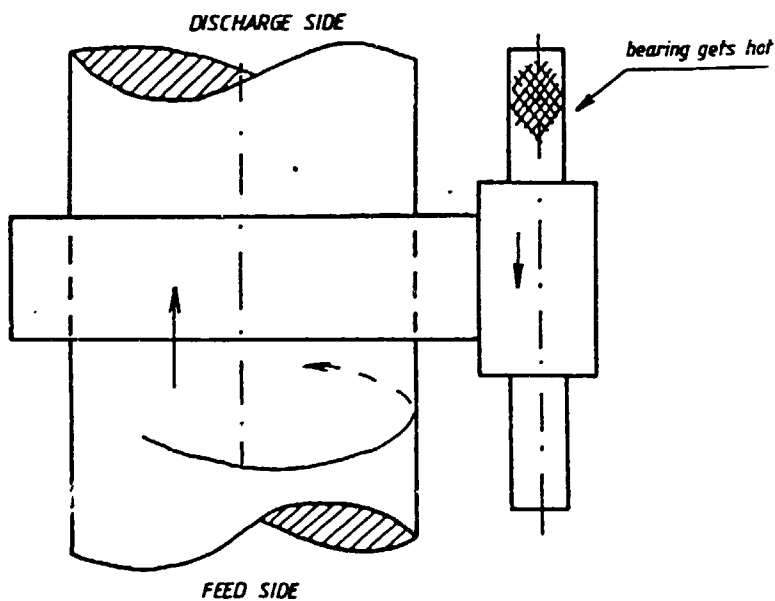


Fig. 15

Figure No.15 presents the roller of type "A" with one of overheated bearing. In most cases mechanics push away the "overheated" end from kiln, but without changing the situation at all, then both ends of roller are carried away from the kiln until the temperature

becomes normal due to the load /kiln weight/ reduction. The described operation results in kiln axis maladjustment, increased load influence on neighbouring rollers and then problems characteristic for non-aligned kiln. The correct operation should be the invert one, namely the overheated pivot should be immediately shoved to the kiln by 1 or 2 mm or the another end of roller should be shoved away from kiln and then cooled the oil and should be changed it, if possible

The described situation concerns the roller type "A", for roller type "B" the operation is quite invert. Moreover, the procedure is different for rollers on the right side of kiln and for rollers on the left side, and another one method should be applied for kiln with the opposite direction of kiln rotations.

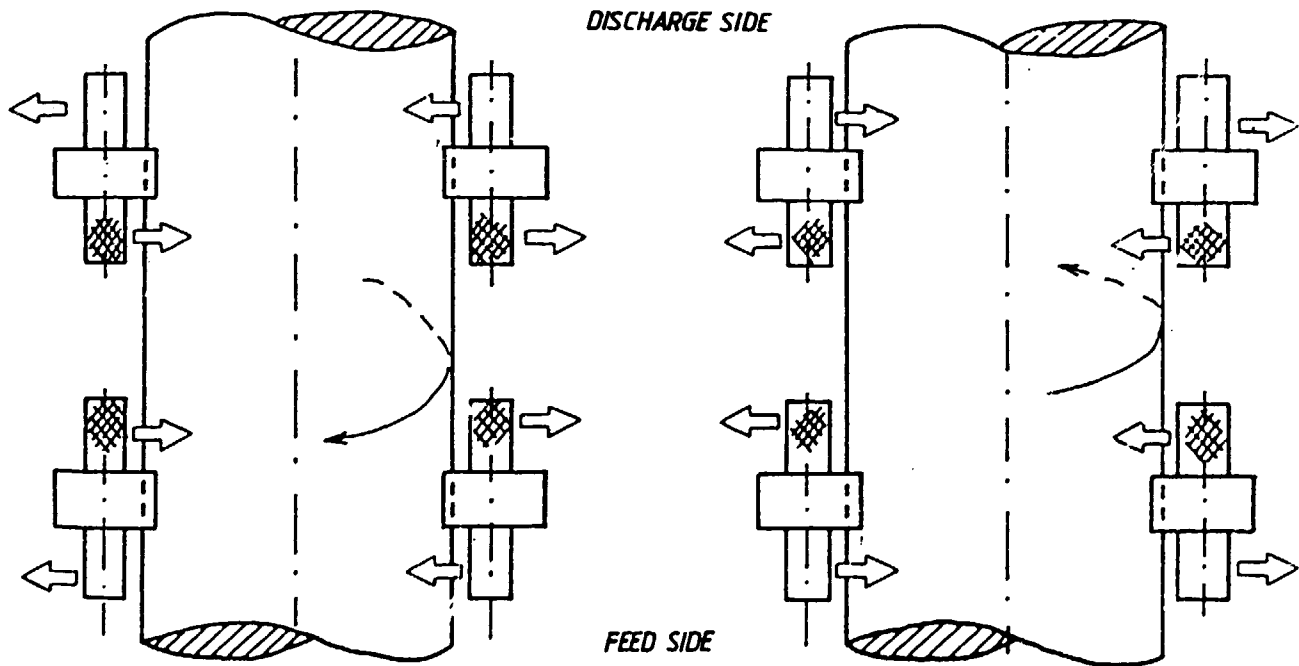


Fig. 16

Figure 16 shows the scheme of the procedure proper for rollers "A" according to the kiln rotations direction, the "overheated" bearings /pivot-bearing bush/ marked with lines and proper directions of correction shifting have been marked as well.

The another reason of rise in temperature of bearings is the axial change of the roller pivot situation towards bearing bushes after the change of the roller axis torsions direction.

Of course, the pivot surface is not perfectly smooth and its convexities and micro-grooves /fig. 17/ fit microgrooves of bearing bush.

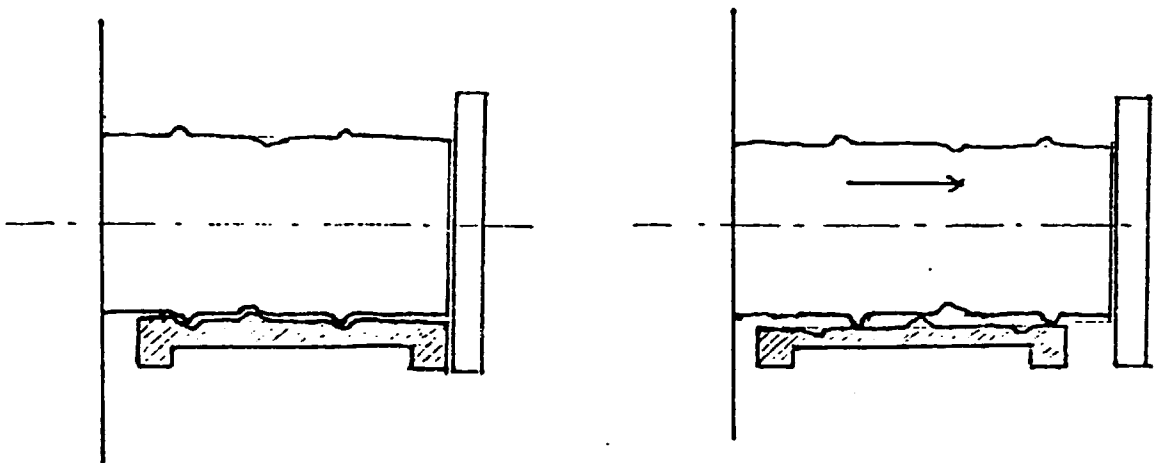


Fig. 17

After the roller torsion is changed the pivot is shifted and the bearing bush should fit the pivot. This causes the rise in temperature; the more cooperating parts are worn-out the higher is the rise in temperature. In this case the roller housing should be cooled, oil should be cooled and special oils or pastes should be applied. / manganese bisulphide / After a certain time the temperature usually is back to normal.

6.2. Axial shift

The axial shift should be corrected after the adjustment or, if necessary, through the rollers torsions.

The axial force direction has been described with full particulars in previous chapters and to make the proper decision the information of chapters 3.3. and 4 could be very useful.

6.3. Change in adjustment variant

During the adjustment it may occur that shifting of one of selected rollers cannot be carried out or the range of shifting is limited.

In that case the adjustment axis situation should be changed so as the corrections of roller were zero. Of course, the roller shifting carried out up to the limit must be also taken into consideration. The calculation of corrections has been described in chapter 3.2.

6.4. Increase in motor power consumption

There was found that directly during the adjustment the motor power consumption increased by ca 10%. This is caused by kiln "setting", axial forces changes, fitting slide bearings etc.

During not very long time /3-5 days/ the power consumption is back to normal and falls by ca 10%.

7. Final comments

The rotary kiln alignment is a complicated process and should be carried out by firm specialized in this process.

Small corrections of rollers situation /axial shift changes, corrections of roller overheated pivots etc./ could be carried out by kiln operation servicing staff.

This paper is to make the servicing staff acquainted with the adjustment rules and to make the deformation survey results more useful.

The results of the recent survey should constitute the basic material used for any correction.

For example, in order to change the excessive kiln axial shift it is enough to turn any of rollers but this would not be the best solution.

The best solution is the analysis of results of recent survey and correction of rollers with biggest torsions through their reduction and the correction of rollers with smallest torsions by extending them.

This procedure gives the additional effect - the possible slightest wear-out of cooperating kiln parts. The same procedure is obligatory in case of kiln position changing at the kiln heads. Shifting the roller placed near the head of kiln is not sufficient - the calculation of all rollers corrections should be taken into consideration while designing new adjustment/alignment axis.

Of course, the procedure should be observed in respect of results of recent survey, which have to be up-to-date ones.

The results of deformation measurements are considered as up-to-date in the course of 1 year under condition that during that time no roller, tire, bearing bush or pivot, roller basis etc. are replaced.

The cost of measurements and adjustment is insignificantly low in relation to the effect - among which the most important are:

- increased productivity of kiln owing to reduced number of standstills
- saving materials and labour necessary for overhauls
- prolongation of lifetime of kiln parts and rollers
- reduction of power consumption necessary for kiln rotation

Special note for those users who never carried out the kiln alignment during the kiln operation and who are convinced that the kiln operates correctly: those users do not know whether the kiln can operate even better.

B I B L I O G R A P H Y

- (1) Gebhardt W. - KILN ALIGNMENT : A PERSPECTIVE
" ROCK PRODUCTS " - october 1989 - USA
- (2) Krystowczyk B. - AUSRICHTEN VON DREHOFEN UND KORREKTUR
DER TRAGROLLEN - VERDREHUNGEN WAHREND
DES BETRIEBES
" ZEMENT, KALK, GIPS " nr 5/1983 - BRD
- (3) Krystowczyk B. - Osłowanie pieców obrotowych w świetle
doświadczeń krajowych i zagranicznych
" CEMENT , WAPNO, GIPS " nr 7/1986
Poland
- (4) Krystowczyk B. - VERMESSUNGEN AN IN DAUERBETRIEB ARBEITENDEN
MASCHINEN UND EINRICHTUNGEN - GEZEIGT
AM BEISPIEL EINES DREHOFEN
" VERMESSUNGS WESSEN UND RAUMORDNUNG "
Heft 7 / Oktober 1986
- (5) Robertson J. - IDEAS AND TRENDS - KILN ALIGNMENT ALLOWS
CORRECTIONS WHILE OPERATING
" ROCK PRODUCTS " - january 1987