



TOGETHER
for a sustainable future

OCCASION

This publication has been made available to the public on the occasion of the 50th anniversary of the United Nations Industrial Development Organisation.



TOGETHER
for a sustainable future

DISCLAIMER

This document has been produced without formal United Nations editing. The designations employed and the presentation of the material in this document do not imply the expression of any opinion whatsoever on the part of the Secretariat of the United Nations Industrial Development Organization (UNIDO) concerning the legal status of any country, territory, city or area or of its authorities, or concerning the delimitation of its frontiers or boundaries, or its economic system or degree of development. Designations such as “developed”, “industrialized” and “developing” are intended for statistical convenience and do not necessarily express a judgment about the stage reached by a particular country or area in the development process. Mention of firm names or commercial products does not constitute an endorsement by UNIDO.

FAIR USE POLICY

Any part of this publication may be quoted and referenced for educational and research purposes without additional permission from UNIDO. However, those who make use of quoting and referencing this publication are requested to follow the Fair Use Policy of giving due credit to UNIDO.

CONTACT

Please contact publications@unido.org for further information concerning UNIDO publications.

For more information about UNIDO, please visit us at www.unido.org

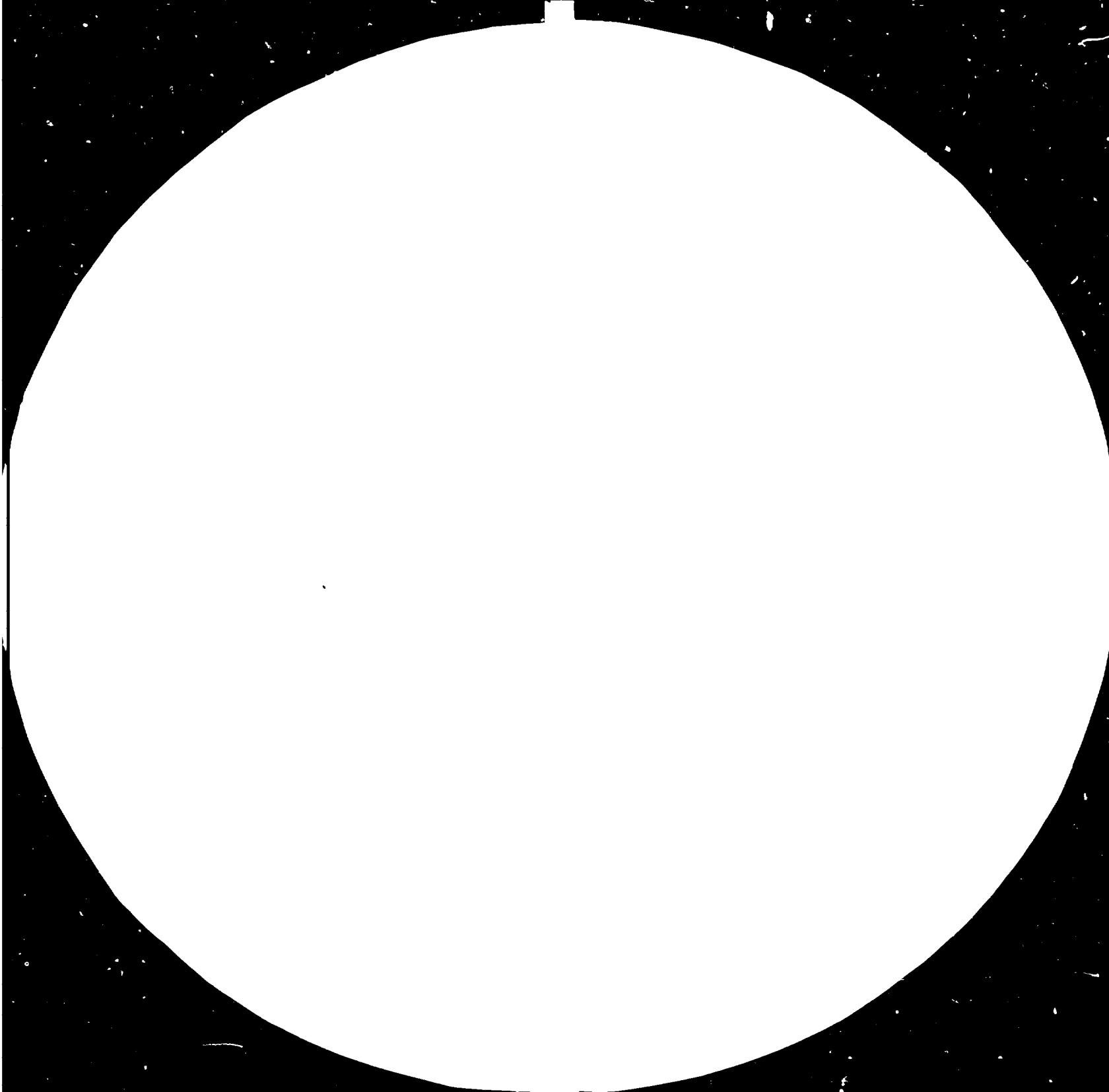



2.8



3.2



3.6



4.0



Resolution Test Chart
1963 Edition
NBS Monograph 17

RESTRICTED

12974

DI/ID/SER.A/463

2 August 1983

English

ASSISTANCE TO ENERGY PRODUCTION FROM BIOMASS
WASTE MATERIALS

DI/TNI/78/200

PHILIPPINES .

Technical report: Low-cost gasification and
pyrolysis systems for energy production*

Prepared for the Government of the Philippines
by the United Nations Industrial Development Organization,
acting as executing agency for the United Nations Development Programme

Based on the work of Prem D. Grover, consultant in
biomass conversion systems

United Nations Industrial Development Organization

Vienna

* This document has been reproduced without formal editing.

V.83 59012

TABLE OF CONTENTS

	<u>Page</u>
List of Figures.	2
1. Introduction	4
2. Summary	8
3. Relevant Pyrolysis Technologies - comparison	11
3.1 Technology Developed Under UNIDO Project	11
3.2 200 kg/hr Coconut Shell Pyrolytic Unit	13
3.3 Kilns Manufactured by R.R.M. Enterprises	15
3.4 Drum Charcoaling Units	19
3.5 Indian Institute of Technology, New Delhi (I.I.T.D.) - Mechanised Unit	23
3.6 I.I.T Delhi Community Level Unit	28
3.7 Steam Gasifier for Rice husk	28
4. Transfer of Pyrolytic Converters and Gasifiers	31
4.1 Modified Drum Charring Units	31
4.2 Mobile Kiln	33
4.2.A Mechanism for Transfer	33
4.2.B Qualifications for the Recipients	34
4.2.C Mode of Operation	35
4.3 Pyrolytic Converters and Rice hull Gasifiers	42
4.3.A Mechanism for Transfer	42
4.3.B Qualifications for the Recipients	43
4.3.B-1 For Pyrolytic Converters	43
4.3.B-II For Rice Hull Gasifier	45
4.3.C Mode of Operation	45

Contents - cont.

		<u>Page</u>
5.	Design of Rice hull Gasifier	47
5.1	Basis for Selection	47
5.2	Reactive Silica	48
5.3	Integrated System	48
5.4	Basis for Process Design	50
5.5	Process Design Parameters	50
5.6	Mechanical Design of the Gasifier	56
5.7	Heat Transfer Characteristics and Furnace Design	58
5.8	Auxiliary Equipment	59
6.	Recommendations	64
7.	Acknowledgment	68
8.	References	69

	<u>FIGURES</u>	<u>NO.</u>	<u>Page</u>
1.	Stationary Kiln (Mesias)	3.1	17
2.	Drum Charring Unit	3.2-3.3	21
3.	Modified Drum Charring Unit	3.4	22
4.	I.I.T.D. Community Level Unit	3.5	29
5.	Integrated System for Rice Sheller	5.1	49
6.	Steam Pyrolysis-cum Gasification of Rice hulls	5.2	51

Contents - cont.

ANNEXURES

- I. COMPARISON OF AVAILABILITY OF DIFFERENT WASTES BY REGION
- II. COCONUT SUPPLY AND UTILISATION PATTERN
- III. PROGRAMME OF VISITS TO LAGUNA, QUEZON AND BICOL PROVINCES
- IV. FABRICATION DRAWINGS OF GASIFIER
- V. FABRICATION DRAWINGS OF BENCH SCALE PYROLYSER
- VI. RICE HUSK STOVE (Sketch and Drawings)

INTRODUCTION

The Philippines is basically an agrarian and forestry based country with abundance of Biomass. But, it has the modern outlook, eager to develop and adopt new and appropriate resource based technologies to raise the standard of its growing population especially in the rural and in the remote islands.

With limited resources of proven fossil fuels, the efficient management and proper utilization of biomass resources, both for commercial and noncommercial energy and fuels, can further play a significant role in the national economy. It is, therefore, most appropriate that UNDP/UNIDO has sponsored four projects out of thirteen projects for the Philippines based on direct utilization of biomass⁽¹⁾.

Considering that the Philippines is the world's premiere producer and exporter of coconut products and by-products with 8.4 million MT of coconuts (about 7×10^4 nuts/year), able to meet 70 percent of world requirements⁽²⁾ and is also net exporter of agricultural produces especially rice, the scope of developmental activities based on biomass resources could be enlarged. This is not only useful for the Philippines, but also for other developing countries, especially in Asia. To cite an example, one ton of rice production is associated with 1.6 ton of residues in the form of rice hull and straw and 92% of the world's rice is

grown and consumed in Asia. In the Philippines, at present, most of these residues are being wasted and disposed off by open fires in the countryside.

The country has enormous variety of biomass residues but the major residues at present under consideration are coconut shells, coconut husk, coir wastes, rice husk, rice straw, sawdust, and milled bagasse. According to Chatterjee⁽³⁾, 3.18 million MT of rice husk and 470 million kg. of sawdust are available. The data for other residues is given in Annexes II.

Further, with the government planning, to set up 70 Dendro (wood) 3 megawatts thermal power plants, each consuming yearly 40,000 tonnes of green wood, the harvesting and processing of which will generate additional amount of wood wastes. This waste could be the additional and potential source of raw materials for its utilization for the technologies being developed under project DP/PHI/78/022, entitled "Assistance to Energy Production from Biomass Wastes".

The project's aim is to develop new sources of energy through the pyrolysis of biomass waste materials with the main purpose to accelerate growth of rural industrialization, without disturbing the ecological and the present domestic energy utilization pattern of the rural population.

This is the report prepared by Professor Prem D. Grover, UNIDO Technical Assistance Expert about his assignment under this project with the Energy Research and Development

Division of the Philippine National Oil Company (PNOC-ERDD) from the period 24th March to 26th April 1983. The scope of the present assignment was then enlarged and period extended to 16th May 1983 to incorporate assistance on the design of an integrated rice hull gasification system for rice mills.

The original purpose of the assignment was to give advise and assistance in developing a proper mechanism for transfer of ownership of various pyrolytic/gasification technologies developed under this project to the private sector.

Under the present project, a two ton/day all purpose pyrolytic converter has been set up at ERDC, Quezon City, which, at present, is undergoing trial runs. While this system is being utilized as a test facility for pyrolysis of various biomass, six more units of pyrolysis/gasification of various capacities are envisaged to be set up for field trials.

Under the present assignment, various appropriate pyrolytic technologies have been critically compared. Suggestions and recommendations have been incorporated to further improve these technologies. The mode of transfer of these technologies and their operation in the field have been dealt with in details. Suggestion regarding development of low-cost stoves, laboratory pyrolyser, utilization of by-products, such as tar, modified drum charring systems with fabrication drawings have been incorporated.

An integrated system incorporating steam gasification of rice husk to generate power and fuel for the rice mills and the recovery of amorphous silica useful for making cement has been proposed. The detailed design of a prototype 25 kg/hr. of rice husk steam gasifier complete with fabrication drawings has been carried out and included in this report. This concept has already been patented by the expert in India, but in view of it's immense potentials for energy generation in developing countries, it is being suggested for its development and dissemination through UNDP/UNIDO.

SUMMARY

Before taking up the main assignment of developing a proper mechanism for transfer of ownership of the pyrolytic converters and gasifiers, it was considered essential to first identify the technologies which are most appropriate for transfer to the field in the Philippines.

The technologies identified are:

1. Modified Drum Charring Units
2. Low-cost Mobile Kiln
3. Modified version of stationary kiln of R.R.M. Enterprises, Manila.
4. 200 kg. per hour - coconut shell and husk pyrolysis unit being designed under the project.
5. I.I.T Delhi Technology for partial pyrolysis and briquetting of small sized biomass wastes.
6. Integrated steam gasification units for rice hulls for generation of power and fuel for rice mills and associated rice hull ash cement plant.
7. I.I.T Delhi community level stationary unit.

The above mentioned technologies (1), (2), and (7) do not have any moving parts so these can be located in remote areas basically for producing charcoal. Amongst the others, except technology (5) (which is already commercialized in India) technologies (3), (4), and (6) have to be integrated with other processing plants to utilize their by-products.

Presently, the potential raw materials being considered are coconut shell and husk, rice straw and rice hull, wood

and sawdust, coir wastes and milled bagasse.

The technologies (1), (2), (3), (4), based on packed bed partial oxidation pyrolysis are most suitable for relatively large sized materials such as coconut shells, lumped husk and wood chips. Rice hull can be pyrolysed as demonstrated in the present facility at ERDC, but the main product, char because of its high ash content has no potential market.

Rice hull, because of its high volatile content and reactive char should be rather gasified by the technology (6). However, rice husk, coir waste, sawdust and milled bagasse can be easily pyrolyzed by technology (5) to give good quality char which then has to be briquetted for commercial utilization.

Modifications to technologies (1), (2), (3), and (4) have been suggested before these could be transferred to the field. Out of these technologies (1) and (7) should be installed and tested in the premises of ERDC, prior to their field demonstration.

The integrated steam gasification unit needs development. Its concept, designs and fabrication drawings have been prepared. A prototype unit to process 25 kg/hr. of rice hull and envisaged to generate 10 kw. of power and 5 kg. of amorphous ash, suitable for making cement, should be installed at ERDC premises.

Based on the technical and financial inputs involved in a specific technology, the recommendations for the transfer of its ownership have been incorporated for pertinent technology. The details of the recipients long term commitment to the

project regarding its operation, maintenance, safe custody of unit and to make available technical, economic and other relevant data have been included in the recommendations. While no financial contributions are required to the project from the recipient, say to transfer the ownership of the empty drum charring unit, a token financial input by the recipients is essential to ensure their continued involvement with the development of other relatively high technology and capital intensive projects.

Suggestions have also been incorporated about the smooth operation of 1 ton/day pyrolytic converter installed at ERDC. Further, know-how and the fabrication drawings of rice husk stove, laboratory scale pyrolyser, already working at Delhi and suggestion to utilize by-products such as tar to protect the working life of the drums and kilns have been included in this report.

3.0 Relevant Pyrolysis Technologies - Comparison

One of the major requirements of any R & D organization is to adopt an appropriate mechanism for the transfer of a technology to the field for its utilization. This aspect is, in fact, most essential yet complicated as it involves not only scientific and development work but also the economics, socio-political acceptability of the system and its end products. Before this aspect is discussed in the proceeding chapters, it is essential to carry out the objective review of the relevant technologies already developed and awaiting for field implementation. Only those technologies considered suitable for the Philippines are discussed and recommendations are also included for any modifications and future development work.

3.1 Technologies Developed Under UNIDO Project PHI/78/022/-10 CHEM.

Tatom⁽⁴⁾ and Chatterjee⁽³⁾ carried out studies for suitable size range of pyrolysis units and availability of raw materials such as coconut shell and husk, rice husks and sawdust. Under the direction of ERDC engineers and with considerable inputs by Tatom an excellent facility has been established by putting up a 2 ton/day prototype pyrolytic convertor. This unit is at present undergoing testing of its various components. While short period test runs have been successfully carried out, prolonged testing and operational data to get material and energy

balances have yet to be obtained.

During the periodical visits to the plant site and in consultation with Dr. Tatom and other engineers of ERDC, certain minor modifications have been suggested to have trouble free operation and also to take meaningful data. These are:

1. Refractory lining of the gas burner chamber which has been carried out.

2. Installation of simple instruments such as manometers - pressure tappings, thermocouple at strategic locations coupled to a temperature recorder (already procured). As of this time, this work is being carried out.

3. Installation of water seals at tar recovery points.

4. Replacement of s.s. screen at four gas outlet ports (which get badly corroded) by a stainless steel punched hole plate having 25 percent free opening area.

Once the abovementioned modifications are carried out and operational experience obtained, one can then comment on the reliability of this unit and if required, suggest major modifications. However, this unit offers excellent opportunities for plant testing of pyrolytic convertor on various raw materials, demonstration of pyrolysis process and training of personnel. It can

generate considerable data and give operational experience, which will be then useful in designing future converters of this type. To enable this unit to be useful for other raw materials such as coconut shells, certain modifications shall have to be carried out by ERDC.

As of this time, the unit is not yet ready to be transferred to the field especially if it is to be used for the pyrolysis of unbroken coconut shells. One could use this facility on disintegrated coconut shells, which will produce charcoal of export quality. It may be mentioned that during the visit to a factory exporting charcoal (m/s Dilag Enterprises, Inc.) in San Pablo City, Laguna, it was observed that the charcoal was being crushed and classified and only the size less than 4 mesh and greater than 32 mesh is considered suitable for export. The finer size less than 32 mesh is being piled up in the factory premises. According to the plant official, this fraction amounts to 10% of the original feedstock amounting to about 1-2 tonnes per week depending upon production.

3.2 200 kg/hr Coconut Shell Pyrolytic Unit

Under the revised project proposal, the emphasis has been made on the pyrolysis of coconut shell and lumped husk rather than on rice husk and sawdust to be integrated with copra and other process industries for utilization

of gases for process heat. This seems appropriate, as vertical bed, partial oxidation - pyrolysis approach is most suitable for large sized feeds and offers much less operational problems especially the bridging in the bed.

Accordingly, the unit has been designed and adequately covered in Tatom's⁽⁵⁾ trip report. The designs are being critically examined by ERDC engineers, along with the suggestions given during the present assignment. A double cone airlock feeding system similar to the one used in the blast furnaces feeding arrangement has been suggested. This will avoid the use of combustible materials like rubber, incorporated in the proposed designs, which during mal-operation may get exposed to hot gases and will have limited life. Further sharp edged material entering with the feed could also damage these materials. It has been observed that charcoal shells disintegrate very rapidly during the partial oxidation pyrolysis. This is due to the rapid decomposition of lignin acting as a binder in coconut shells. Therefore, the occasional breaking of the coconut shell during feeding is not a critical parameter. The size of the charcoal produced can be controlled only by adjusting the operating parameters during carbonization. Slow rate of heating and greater residence time will tend to give comparatively large sized charcoal. But this will have adverse effect on the rate of production in a

particular pyrolyzer.

The abovementioned unit, after critical examination of the designs by ERDC can be got fabricated and is a potential unit for its applications in the field.

3.3 Kilns Manufactured by RRM Enterprises

Mr. Romulo Mesias of RRM enterprises, who has been frequently quoted before in the earlier reports, has been identified as an experienced charcoal and copra processor in Manila. He is also a fabricator and building processing plants in the Philippines. M/S RRM Enterprises have been offering two type of kilns: A mobile unit and a stationary type with recycling of gases. These are basically used for coconut shell and husks.

Mobil Kiln Unit

This is a simple kiln with complete manual operator and has been described in the earlier report.⁽³⁾ According to Mr. Mesias, this kiln has a capacity to produce 500 kg. of charcoal in 16 hours with a yield of 20% based on undried coconut shell. Since it does not require any electric power, this can be operated in the remote areas near the vicinity of coconut plantations. As I understand two such kilns are being purchased by ERDC to carry out tests on their performance and prolonged reliability of these equipment and for further modifications. In this unit,

no recovery of the by-products is made and the process heat is also not utilized.

Stationary Kiln Unit

RRM Enterprises has also developed a vertical kiln in which the gases are trapped from above and recycled into the combustion zone. The flue gases are then drawn out and used as a process heat. During the visit to RRM factory, the operation of this kiln was demonstrated. The schematic sketch of this kiln is shown in Figure 3.1.

According to Mr. Mesias, this set-up, which requires minimum two electric power driven blowers for recycling of gases and process heat recovery can produce 500-800 kg. of charcoal in 16 hours with an improved yield of 25-30 percent. A condenser can also be incorporated in the recycle gas line (shown as "C" Figure 3.1) to recover the tar products and also to prevent tar entering into the blower to avoid corrosion problems. The present set-up seems to be an appropriate design worthy of field trials in an integrated charcoal cum copra processing and/or charcoal cum other process industries, where process heat can be utilized for drying or steam generation such as cattle feed preparation or pesticide formulation units.

Although, its operation has been demonstrated, it needs field testing and incorporation of many modifications. The present problem is the huge quantity of smoke emitted

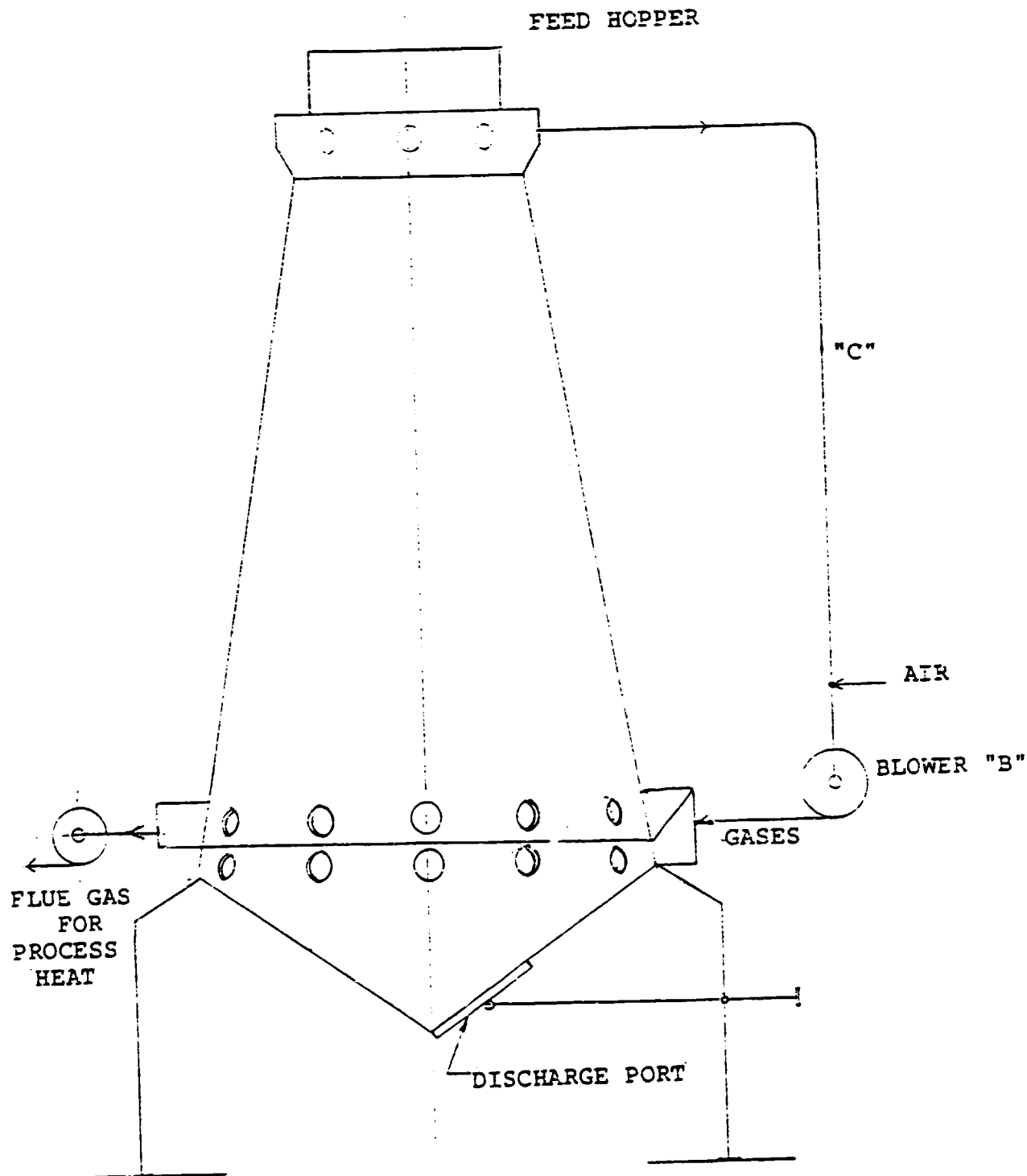

FIG. 3.1 STATIONARY KILN (Mesias)

from the feed hopper which could only be eliminated by proper balancing of the blower speeds. In order to incorporate the use of this kiln under the project, the following modifications on the existing unit are suggested:

1. To eliminate smoke emitting from the feed hopper, the pressure should be slightly below atmosphere near the feed hopper opening. As the amount of gases produced shall not be uniform during operation, a variable motor should be provided with the recycle gas blower "B".

2. The mild steel sheet near the combustion zone and other areas where the temperature is more than 250°C, refractory alumina based cement should be provided to protect the material of construction from excessive oxidative high temperature corrosion.

3. The area below the combustion zone should be further increased and air required for combustion should be passed over this zone to indirectly cool the charcoal. The red hot charcoal presently being removed gets burnt once taken out and not quenched with water immediately. Alternatively, the system used in ERDC pyrolyzer for char removal can be adopted with this kiln.

4. This kiln will approximately need 200 kg. of raw material per hour. The feeding system can be mechanized by having skip hoist bucket system.

In view of its inherent advantages of by-product recovery and heat economy system, one such unit be purchased and after doing these modifications can be transferred to the field for its operation and performance testing.

3.4 Drum Charcoaling Units

According to Philippine Coconut Authority (PCA) in 1982 about 114,000 tonnes of charcoal was produced in the country (Annexes II). Only four major charcoal producing organizations having total capacity of 30,000 MT are listed with PCA. Assuming that these companies are using kiln method, a substantial amount of charcoal, i.e. 74% of total production, is being made by pit method and also by oil drum method. Although the drum method is widely practiced in the Philippines, yet its popularity is restricted because of the relatively short life of the drums due to excessive oxidation corrosion on the outside exposed surface of the drum. Depending upon its operation, the life of the drum is estimated between 3-12 months.

By far, the most popular system of charcoaling will be drum method, because of its low initial investment. An empty drum or barrel costs about ₱120.00 (\$12) and 20-25 kilos of charcoal can be produced in 3-4 hours. One person can handle 4-10 such drum provided these are properly designed. According to Medrano et al⁽⁶⁾, the

charcoaling operation in drums is generally conducted in a battery of 50-150 drum kilns. With one drum per burn in a day, a farmer can earn anything from ₱15.00 (Fifteen Pesos) to ₱30.00 (Thirty Pesos) a day.

Considering the importance of this cottage level, low technical input employment potential technology, it is recommended that at least three models of these drums should be scientifically investigated and the best and easily operational system should also be transferred to field to the progressive farmers with small landholdings. These designs are shown in Figures 3.2, 3.3, and 3.4, suggested by Medrano⁽⁶⁾, Grover⁽⁷⁾, and Mesias, of RRM Enterprises, respectively.

Another important aspect to be considered during its development is to recover a small quantity of TAR during the charcoaling operation. This tar after simple processing can be painted on the outside surface of the drum to significantly prolong its physical life. The drum system designed by Mesias can be, therefore, more appropriate for modifications as suggested in Figure 3.5.

The tar collected will be mixed with particulates (ash etc.) and being acidic in nature should be processed by the following method.

The collected tar should be washed with hot water (70-80°C) and the water should be physically separated

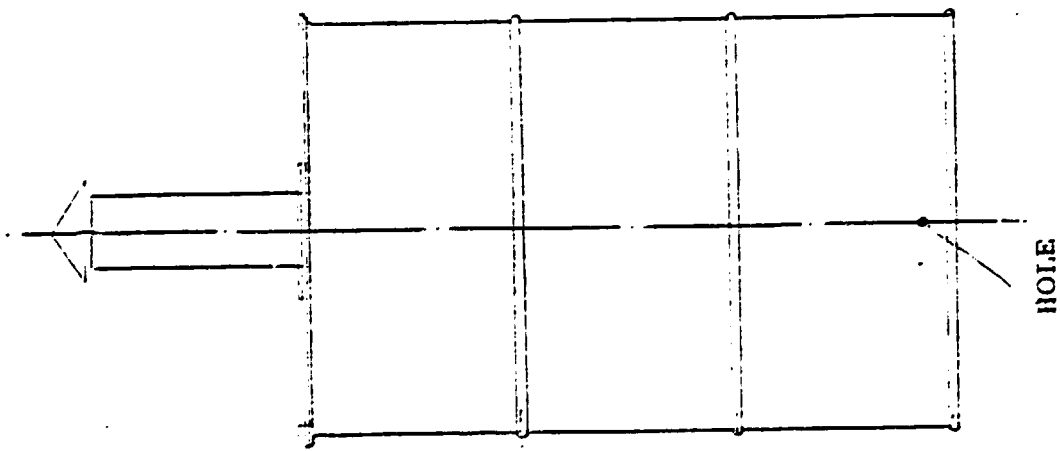

FIG. 3.2 (Ref. 6)

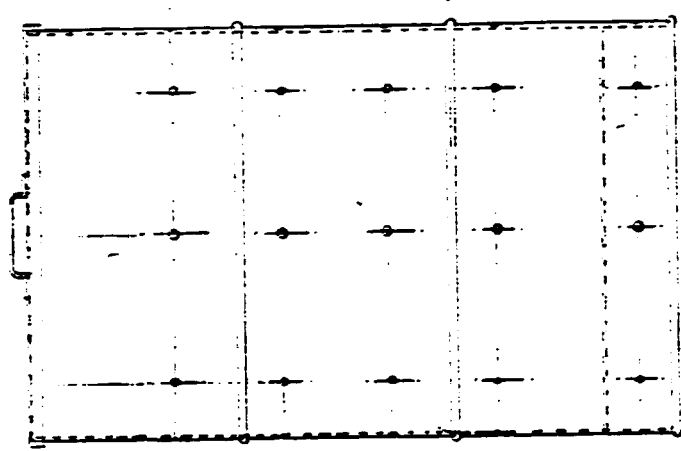

FIG. 3.3 (Ref. 7)

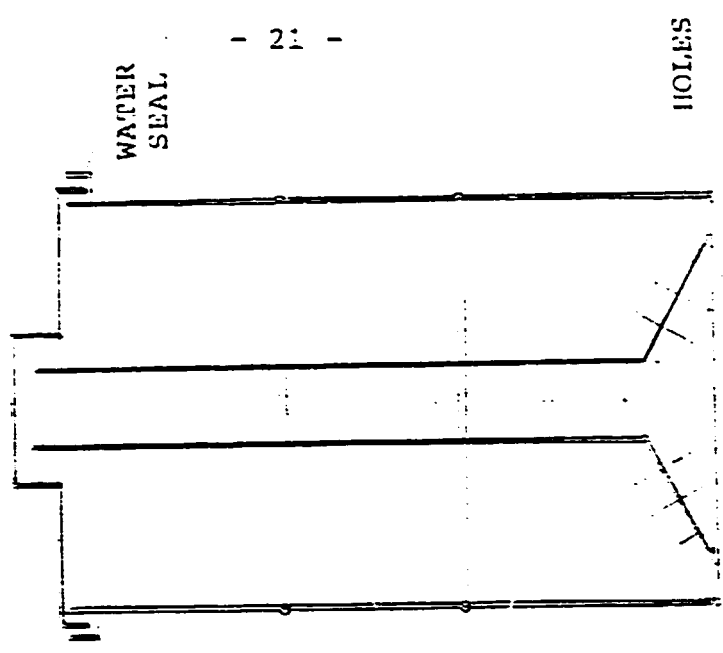

FIG. 3.3 (Mesias)

DRUM CHARRING UNITS

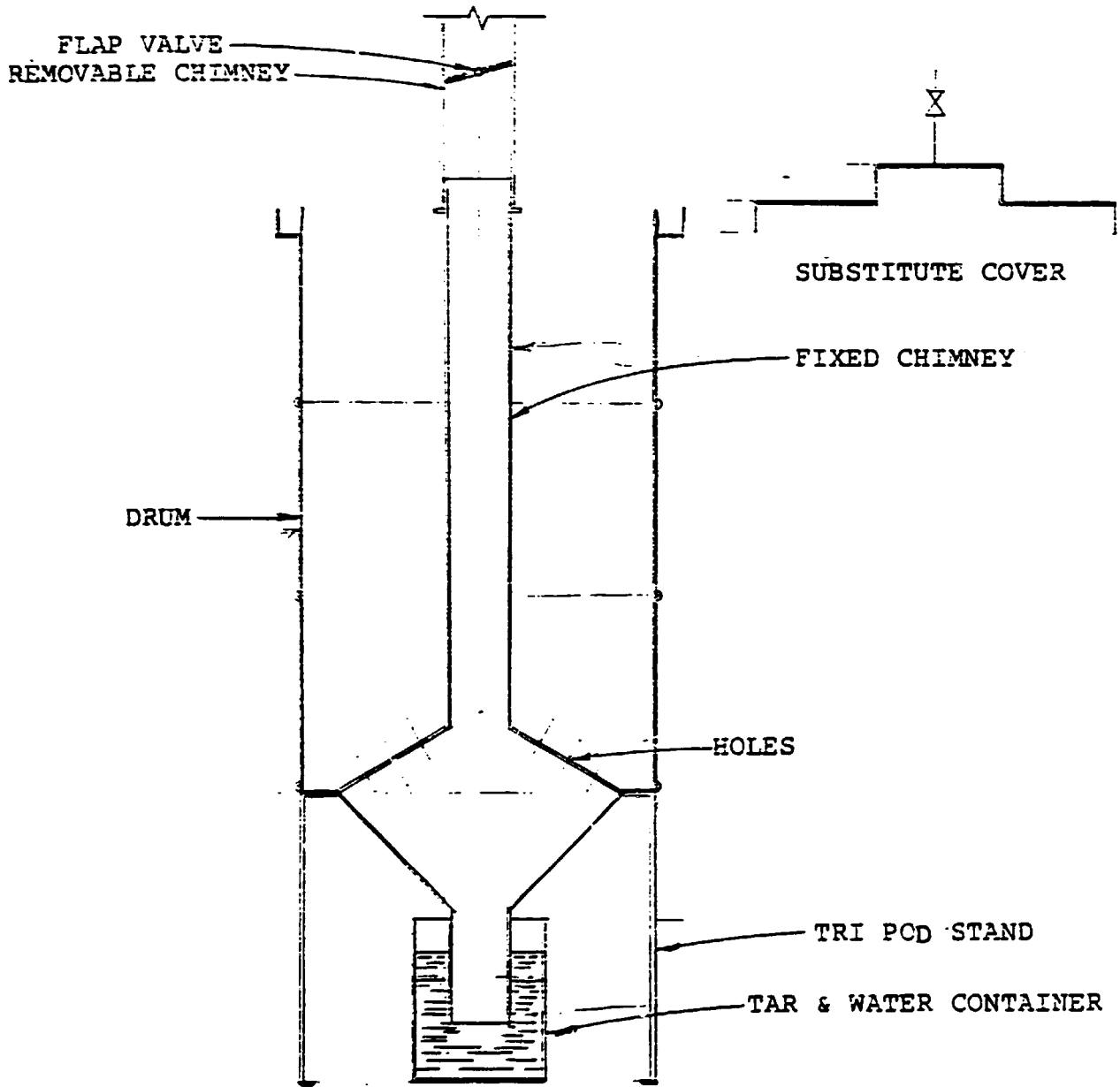

FIG. 3.4 MODIFIED DRUM UNIT

from tar by decantation. Two to four washings may be needed to remove the acidity of the tar. This tar can then be slowly heated to remove entrained water and brought to a proper consistency that it can be applied on the drum with a paint brush. Filtration through ordinary cloth may be necessary in case ash content is high. After this application, the drum should be immediately used for charcoaling operation. Due to the heat produced during this operation, the tar will thermally crack leaving a coating of cracked carbon. This process may have to be repeated 4-5 times initially till the deposition of carbon is rather uniform. The coating of this carbon shall protect the outside surface of the drum, from corrosion. The application of tar may be repeated now at longer intervals as and when signs of corrosion appear on the drum surface. Over prolonged use, the carbon may turn graphitic in nature.

3.5 Indian Institute of Technology, New Delhi, (IITD)
Mechanized Technology

Before this technology is discussed, it is appropriate to describe the proper utilization pattern of various raw materials by different pyrolysis-gasification technologies: Coconut shell and husk can be pyrolyzed in a partially oxidized vertical shaft kiln while there are many operational problems to utilize the same system for finer materials

like sawdust, coir waste. Rice husk can be tried in shaft kiln with some modifications as carried out and/or contemplated for the kiln of the type now installed at ERDC. But as proposed in the revised programme of work, rice husk should be gasified rather than converted into char and then be briquetted. During the present trip, a steam gasifier system is being designed for installation.

In case, rice husk, sawdust, coir waste, bagasse, has to be converted into charcoal, an indirectly heated horizontal auger type retort pyrolysis system similar to one developed by Grover⁽⁷⁾ (8) has to be adopted. This system is already commercialized in India, more than ten plants are operating, many more are being installed. The technology and economics of the plant along with concept of partial pyrolysis was presented to the staff in a seminar on April 22, 1983 at ERDC. This system produces 4 tons of briquetted fuels based on rice husk in 24 hours and consists of continuous pyrolysis system with recycling of gases, blender, extruder, and drier. I.I.T. Delhi shall be willing to transfer this technology to other countries. However, before the technology is considered for formal transfer to ERDC and/or other agency in the Philippines, it is recommended that a senior official from ERDC should visit India and carry out the assessment of these plants before its transfer to the Philippines is considered.



Coconut Plantation in Region IV Southern Tagalog Philippines

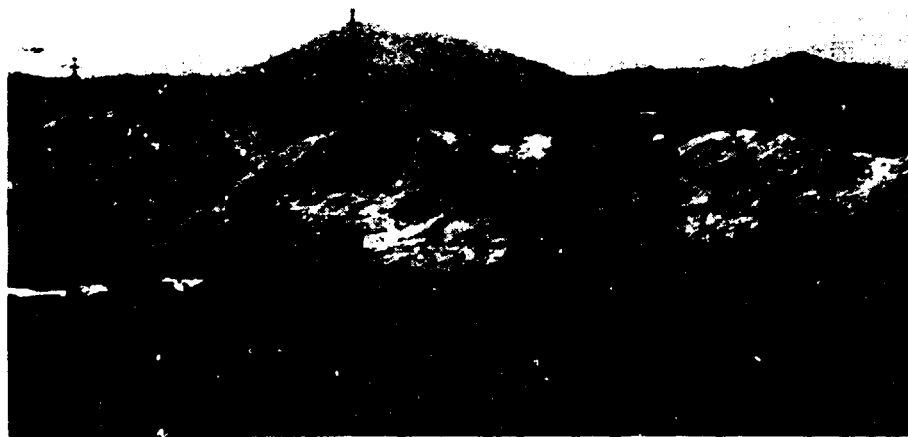

Rice hull being burnt in the Field in Region IV



Drum Charcoaling units (RMM Enterprises Manila)
(Charcoal from Green Coconut Husk)



Drum with Cover



Conventional Drum Charcoaling in the Field



Small Scale Charcoal Gasifiers being produced by
Gasifier and Equipment Manufacturing Corp.
Manila, Philippines

3.6 I.I.T Delhi Community Level Unit

Based on Laboratory test, a multitray cupola type unit has been designed by Grover⁽⁹⁾ at I.I.T Delhi. This is a stationary type of masonry cupola cum tray pyrolysis unit which can be used in remote areas for pyrolysis of relatively irregular and smaller sized materials such as small branches, twigs, leaves, sawdust, coir dust, bagasse, and rice husk. This requires no electricity and so none of the by-products are recovered. It has the advantage that ashes of the fuel used to provide heat for pyrolysis do not get mixed with the main product, i.e. powdered charcoal. This product can then be mixed with binders and briquetted with a hand operated briquetting machines and dried in sun.

The design of a bench scale tray pyrolytic convertor, similar to one used at I.I.T Delhi has been prepared and transferred to ERDC. The working drawings are given in Annex VI.

The design for a commercial community-type prototype units are being prepared and transferred to ERDC. The schematic drawing is shown in Figure 3.5.

3.7 Steam Gasifier for Rice Husk

Because of the two inherent properties of rice husk, that is, high volatile content and reactive char, it is most desirable to gasify these into pyro-gas which has normally 2-3 times higher calorific value than that of

- 1 FIRE BRICK.
- 2 SIMPLE BRICK.
- 5 FEED CHARGING + REMOVAL DOORS

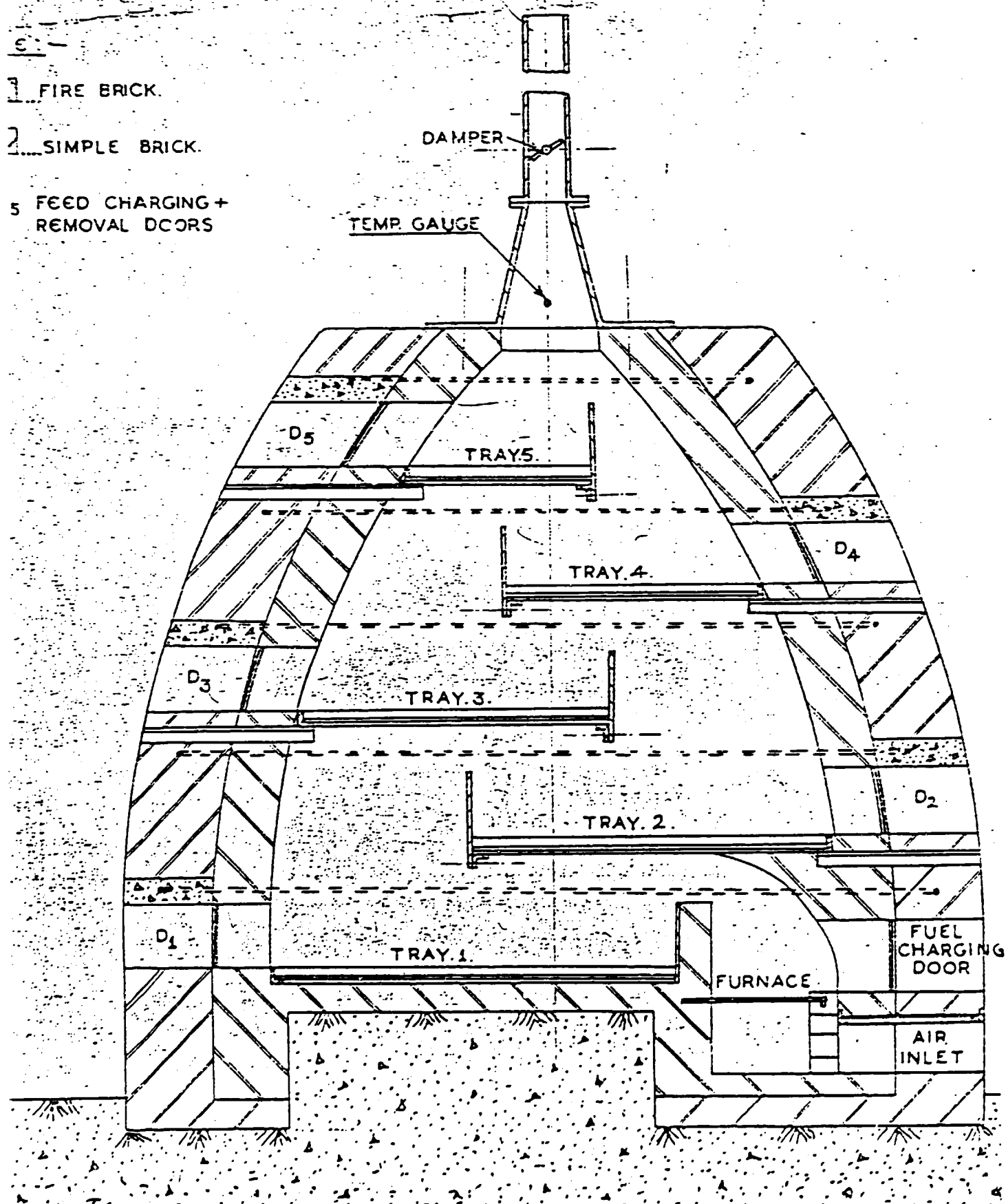

Fig 3.6 COMMUNITY LEVEL UNIT

producer gas. The pyro-gas after proper cleaning can be used as good quality fuel and as gas for running stationary Internal Combustion Engines to produce mechanical and/or electrical power. At this time of writing this report, it is decided to prepare the working drawings of this unit. In addition to production of gas, the reactive silica present in the rice husks is also recovered which is a useful material for making pozzuolana cement. This cement can be cast into hollow blocks being extensively used in the Philippines for the construction of houses.

4. TRANSFER OF PYROLYTIC CONVERTERS AND GASIFIERS

In the previous chapter, the various appropriate pyrolytic converters and gasifiers developed and/or under development have been described. The mechanism for transfer of these technologies shall be different for different units, depending upon the extent of technical and financial inputs involved and the socio-economic cost benefits of each of these systems.

4.1 Modified Drum Charring Units

This cottage level appropriate technology has been described in Section 3.4. Although, this technology with least technical and financial inputs have not be specifically included in the project document (PHI/78/022/A/01/37), but it meets the basic purpose of the project, i.e., improving the quality of rural life, and the development of rural industries. Being simple, this is likely to be adopted immediately and shall be widespread in its utilization. Therefore, it needs special considerations in the Philippines and other developing countries.

Three such units as described in Section 3.4 should be constructed, tested and the improved and most appropriate units should then be transferred to the field.

About 3-10 drums should be fabricated and handed out of the progressive farmers who are already making

charcoal by pit methods in various regions of the country. At least 5 such units should be installed in Regions IV (Southern Tagalog) and V (Bicol) because of their proximity, and abundant availability of raw materials.

Field demonstration and also open house demonstration at ERDC should be arranged and technology popularized through publications and by the use of mass media communication system.

This technology should also be transferred to various government and private agencies involved with rural development and promotion of small scale industries, such as, Institute for Small Scale Industries, University of the Philippines. The latter, during discussions, has shown keen interest in promoting the improved version of this technology.

During the routine tours of the provinces, the ERDC technical staff should visit these recipients to guide them and also get the feed back about their operations and working life of these drums incorporating preventive corrosion measures as recommended in Section 3.4.

Detailed manuals in simple and local language should be prepared and got distributed to the interested farmers and other entrepreneurs.

4.2 Mobile Kiln

As described in Section 3.3, this kiln has no moving parts and has a capacity to make 500 kg. of charcoal in 16 hours. Unlike modified drum charring units which gives sufficient quantity of tar, to be used as protective coating on drums, this unit does not have this provision. However, tar obtained from drum or other pyrolytic converters can be used to coat these kilns to increase their operating life.

A. Mechanism for Transfer

Two such units can be got fabricated and installed at two different locations in the remote areas near the coconut plantations, which have already dehusking and copra drying activities such that coconut shells are easily available. To produce 500 kg. of charcoal, the coconut shell required shall be 2.5 M tons per day, so the suitable location shall be in Southern Tagalog region as far as possible near the close proximity of Manila so that the product can be transported at relatively cheaper cost, either for local consumption and/or for export.

At least 20% share of the capital cost of the equipment should be paid by the recipients.

The main objective is not to get any finances, but to ensure their direct and continued involvement in the development

of the project. A nominal financial commitment shall make the recipients more conscious of their responsibilities towards the project.

B. Qualifications for the Recipients

1. The recipients of these kilns could be either an individual or a corporate body.
2. The recipients should have experience in trading and/or manufacturing of charcoal from coconut shells and/or other woody biomass. This will ensure that the recipients can procure the raw materials and also able to sell the products, so that the unit is well tested over a prolonged period of time.
3. The recipients should have broad outlook and quality conscious and evidence of sincerity to the development of the project by their past records should be established by them to the satisfaction of PNCC/ERDC authorities.
4. The recipients should have the finances to the extent of working capital and the evidence of that should be established.
5. The recipients should submit a project report giving in details the facilities and infrastructure already available and labor inputs with economic and profitability analysis. The authorities should make sure that the recipients shall be drawing reasonable

profits which in turn will ensure the operation of the kiln and generation of relevant data.

C. Mode of Operation

The recipients shall have their long-term commitment to the development of the unit for a period to be decided by ERDC authorities. The period should be long enough to test the operational reliability of the unit. For this kiln, a period of 12 months, from the start of the actual operation, should be sufficient. This will enable the ERDC engineers to take data during all weather conditions including the corrosion rate data during the rainy season, when the kiln may not be operated. After all possible commitments are honoured by the recipients and sufficient data have been obtained, the government should have the discretion to transfer the ownership of the kilns to the recipients. Till such time, the kilns belong to ERDC, and the recipients shall be responsible for its safe custody and any willful damage and/or to loss of the equipment shall be compensated by the recipients.

In addition, the recipients shall have the following commitments to the projects:

1. Operation of the Plant

- (a) The unit shall be operated by the recipients for a sufficient period of time to be mutually decided by the recipients and ERDC so that meaningful

operational data could be obtained.

- (b) The recipients shall maintain an operational log book recording therein the time and duration of operation, actual consumption of raw materials and yield obtained, measurement of operating data such as temperature, etc., and any operational problems or breakdown experienced. A sample of blank log book form should be provided by ERDC engineers.
- (c) The operational data shall be made available to ERDC. Further, ERDC engineers shall have a free access to the plant to study its operation and take any technical data suitable for the development of the unit. Samples of raw material, by-products, and finished products shall be made available to ERDC engineers as and when required for analysis in ERDC laboratories. It is recommended that proximate analysis of these materials should be periodically carried out.

2. Maintenance -

- (a) The recipients shall be responsible for the preventive and break-down maintenance of the unit. However, if the breakdown occurs due to faulty design and/or

manufacturing defects, it shall fall under the preview of modifications. A preventive maintenance schedule should be provided by ERDC. The plant should be operated within the capacity limits envisaged by ERDC to avoid frequent breakdowns.

3. Modifications -

(a) Any modifications to improve the yield, capacity and quality of the products should be carried out with the prior consent of ERDC engineers incharge of the unit.

Minor modifications costing up to 2.5% of the cost of unit limited to the maximum of ₦500 should be carried out by the recipients.

(b) Any major modifications suggested and/or approved by ERDC costing more than the above limits should be carried out by ERDC. However, ERDC at their discretion may claim 20% of the capital cost of the expenditure from the recipient. This is applicable only during the period, until the ownership of the unit has been fully transferred to the recipients.

4. Instrumentations -

Any instruments installed for the purpose of testing and generation of data, which do

not form the integral part of the unit and not specifically required for its operation shall be the property of ERDC. These instruments shall be removed before the ownership is transferred. The recipients shall have no claim on these instruments and/or other peripheral equipment installed for the purpose of testing.

5. Economic Data -

The recipients are required to furnish every type of cost data, as and when required by ERDC to enable them to carry out socio-economic cost/benefit analysis. These shall include:

- i) Pattern of collection of raw materials.
- ii) Cost of raw material paid to the producers.
- iii) Cost of collection.
- iv) In-plant raw material cost.
- v) Cost of auxiliaries. In this case, water, power, if any, and fuel for lighting, etc.
- vi) Labor benefits and other payroll expenses.
- vii) Finance charges.
- viii) Cost of both direct and indirect labor involved in processing.
- ix) Finance charges.
- x) Pattern of sale of products and by-products.
- xi) Sale promotion expenses.

xii) Sale price of the products.

xiii) Overhead expenses not already included.

6. Rights to Manufacture Plants -

The recipients, after complete testing and modifications of the plant, shall have the first right to fabricate these plants and sell these to other entrepreneurs as per specifications recommended by ERDC engineers. However, such rights shall not be on exclusive basis as the information obtained under this project is for general dissemination. ERDC has the rights to pass on the information to other fabricators in the Philippines, provided the demand of such units is significant. This will also promote healthy competition.

7. Financial Management -

The financial management of the plant shall be the sole responsibility of the recipients. On no account, the ERDC and other agencies involved in the development of this technology including UNIDO shall be held responsible for any financial losses, including losses by fire and other calamities. However, ERDC may recommend to the financial institutions to provide soft loans funds, etc., on priority basis with the sole purpose to accelerate the development of this appropriate

technology. The repayment terms and the required back-up guarantees solely rest with the recipients.

8. Technical Inputs -

While all possible efforts should be made by ERDC to provide technical inputs on continued basis to the units and modifications carried out as and when required, but being a development projects, at no stage ERDC can be held responsible for partial or total failure of the unit to meet the rated capacity, quality envisaged and yields of the products and by-products.

9. Auxiliary Equipment

In addition to the basic infrastructure, all types of auxiliary equipment such as storage bins - buckets or sacks, weighing scales, etc., other consumable and non-consumable hardwares, and tools, chemicals, etc. shall be provided by the recipients.

10. Movement of the Units

Under no circumstances the units should be removed from the selected site to any other premises without the prior consent of ERDC. Exception can be made in the case of mobile kiln. In case of its movement to a new site its new location should be immediately communicated to ERDC engineers.

11. Termination of Association

At any stage during development of the technology under the field conditions if the recipients get disinterested and are unable to operate the plant due to any unforeseen reasons, ERDC should have the right to take back the plant/unit and transfer it to another party or individual. This termination shall be equally applicable in case the recipients do not honour their commitments to the project including noncooperation and their inability or refusal to give technical, economic and other relevant data vital to the development of this project.

In the event of termination of association on the above grounds, the capital share of the recipient should not be paid back.

4.3 Pyrolytic Converters and Rice Hull Gasifiers

This section deals with the 200 kg/hr coconut shell pyrolytic unit (Section 3.2), stationary kiln unit (Section 3.3) and gasifier of rice hulls (Chapter 4)..

All the above units are under different stages of development except the stationary kiln unit which is operational at the premises of m/s RRM Enterprises but needs modifications as mentioned in Section 3.3. All these units have a common feature that these are comparatively more capital-intensive than that described in Section 4.2. Further, these units shall have to be integrated with other processing plants to utilize their combustible gases either for heat or generation of electricity. The adoption of these technologies in the field requires additional qualifications of the recipients and their deeper involvement and longer term commitment to the projects than those outlined in Section 4.2.

A. Mechanism for Transfer

One unit each of abovementioned pyrolytic converter and one rice hull gasifier should be transferred for field operation. While the pyrolytic converters based on coconut shell and husk could be located in Southern Tagalog Region IV, as far as possible within the close proximity of Manila, the gasifier based on rice hull could be installed either in Central Luzon Region III or Region IV as both these provinces have large concentration of rice mills as given in annexure II-B.

The mechanism of transfer shall be the same as described in Section 4.2-A. However, because of greater degree of involvement, envisaged on the part of the recipients, the financial share of the recipients should be 30% of the installed cost of the plant. ERDC shall meet 70% of the cost of the pyrolytic converters and by-product recovery system. However, the cost of downstream equipment for the utilisation of gas for drying of copra, agricultural products and its use as a process heat for process industries shall be borne by the recipients.

In the case of a rice hull gasifier, ^{except} the storage of gas and its utilisation as a source of process heat and/or power generation, ^{cost of} the its distribution system shall also be borne by the recipients. Because this technology shall be first tested in ERDC premises and transferred to the field as a developed technology.

B. Qualifications for the recipients

B.I For Pyrolytic converters

- (1) The terms 1, 3, 4, and 5 already recommended in Section 4.2.3 are equally applicable. In addition, the recipients should have the following qualifications.
- (2) The recipients should be technically qualified having a degree in Mechanical/Chemical/Agricultural Engineering or equivalent. A technical personnel with extensive experience in process engineering industries may be considered as an

equivalent qualification. Alternately, the recipients should have enough financial resources to hire at least one senior and experienced person having the above qualifications.

- (3) The recipients should have experience in charcoal trading and manufacturing and/or in the trading and processing of agricultural products and residues, either for food or fuel or fodder. This will ensure that the recipients are capable of procuring raw materials and proper sale of the finished products. Experience in fabrication of process equipment and running a process industries dealing with agricultural and forestry products or products needed as agricultural inputs such as fertilizers, pesticides, etc. should be considered as an equivalent experience.
- (4) The recipients should be able to provide an industrial shed in an easily accessible area duly approved by the local authorities for the setting up of the process industries. In addition to the industrial shed, the site should have basic infrastructure such as availability of continuous supply of electricity, water and close proximity to a provincial town or city for easy availability of engineering goods and with an enclosed open area with proper security arrangements.

B. II For Rice Hull Gasifier

- (1) In addition to the terms described in Section 4.3.B.I it is desirable that the recipients should have long and reputed experience in the rice shelling industries and they are in a position to procure rice hull from their and other surrounding mills up to the extent of 5 tons per day.

C. Mode of Operation

The terms and conditions for the transfer of technology should be basically the same as given in Section including 4.2.C, items 1 to 11.

However, the commitment of the recipients shall be for a longer period. It is envisaged that a close cooperation of at least two years is desirable.

Further the absolute share of capital amount to be paid by the recipient being relatively large, this may be recovered, on the discretion of the government, in three equal installments. The first installment payable at the time of contract, the second after 6 months from the actual start of operation and the final after 12 months from the start of operation. No interest may be charged. However, if the installments are defaulted, and paid beyond the stipulated period, normal rate of interest as applicable in the case of commercial banks in the Philippines may be charged.

The objectives of these terms is not to make any profits but to ensure that the continued involvement and cooperation of the recipients is ensured.

5. Design of Rice hull Gasifier

The period of the present assignment was extended in order to design a small prototype gasifier for rice hull, in which in addition to gasification under controlled operating conditions, the amorphous silica could also be recovered.

5.1 Basis for Selection

Rice husk has two basic inherent properties of reactive char and high percentage of volatiles. During pyrolysis of rice hull, all the volatiles can be removed and the fixed carbon and carbon formed during pyrolysis remain as char imbedded with silica. In normal gasification process, to have water-gas shift reaction with carbon, the silica acts as a physical barrier. In the rotary gasifier, the char once formed can be physically disintegrated, thereby, liberating the carbon which can then be gasified.

The other main objective is to carry out gasification at relatively lower temperature, definitely, below the critical temperature of rice hull ash. In normal gasification and combustion processes, the temperature is normally far above 900 °C to 1000°C beyond the critical temperature of 650-760°C, when the reactive-amorphous silica changes to crystalline structure thereby losing its importance. To carry out gasification below 700°C, an atmosphere of steam is essential. This process known as steam gasification can be easily carried out in^a rotary type gasifier.

By this process, not only pyro-gas, having heating values in the range of 2889-5156 Kcal/m³ (325-580 BTU/ft³) compared to that of producer gas (120-180 BTU/cu.ft) is generated, but the amorphous silica is also recovered.

5.2 Reactive Silica

Rice hull contains 20% amorphous silica which is used for making acid resistant hydraulic cement and reinforcing filler for rubber industry. It can also be used as such or mixed with portland cement. In the Philippines, this cement can be used for making hollow blocks used extensively in construction of buildings. Some of the tests on rice hull cement have been carried out by Mehta and Pitt⁽¹⁰⁾ In India, a number of rice hull cement plants were established but due to improper recovery of amorphous grade silica the quality of the product suffered and could not compete with Portland cement. So it is essential that during pyrolysis - gasification, the temperature must be kept below 700°C, the provision for which has been incorporated in the present design.

5.3 Integrated System

Once this process becomes operational and the scale-up data has been obtained on the prototype units. This unit should be integrated with rice sheller so that energy produced can be fed back to the sheller and the cement mixing plant. This approach is shown in Fig. 5.1.

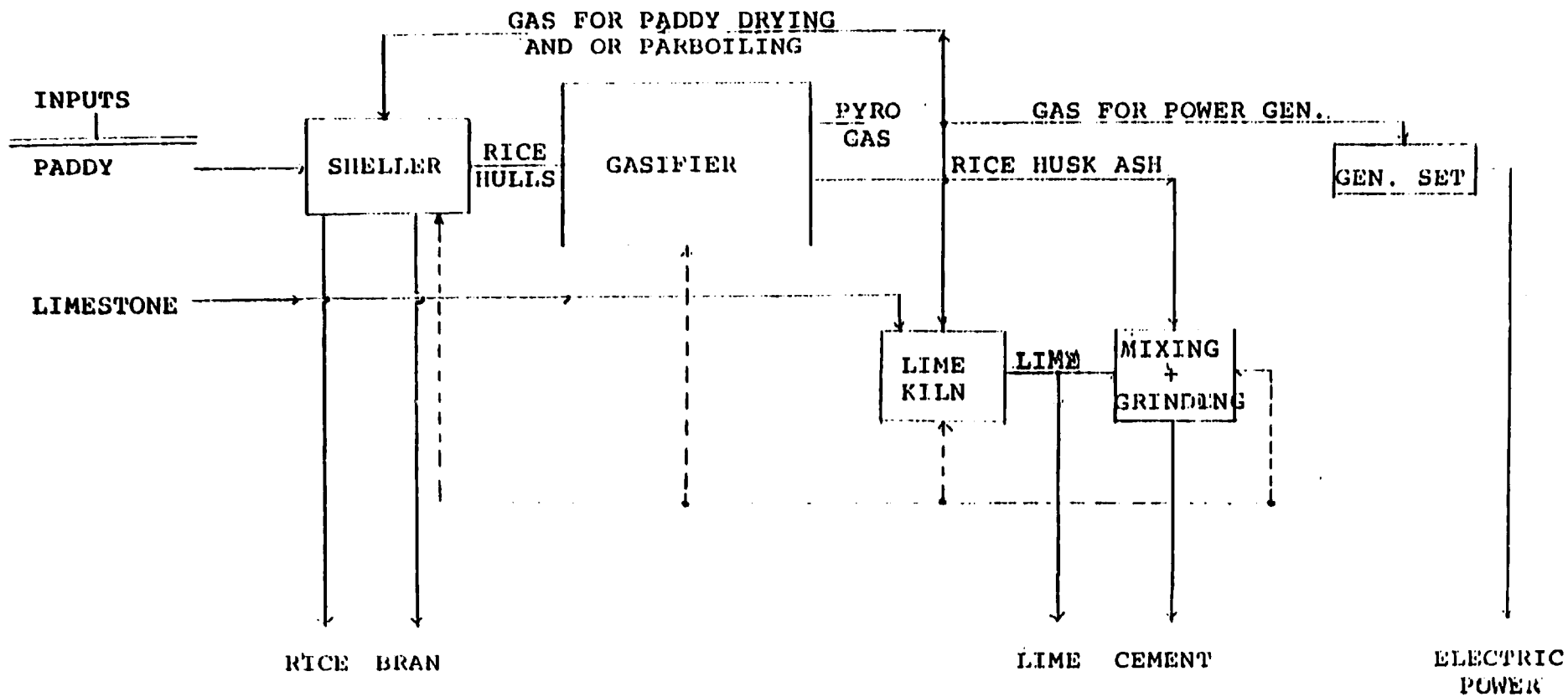

FIG. 5.1 INTEGRATED SYSTEM FOR UTILIZATION OF RICE HULLS FOR RICE SHELLER

5.4 Basis for Process Design

The main-reactor is of conventional design, but has novel modifications. It is therefore desirable to have a capacity which is manageable in ERDC and yet large enough to give meaningful data suitable for the design of future commercial unit. Taking these considerations, a capacity to process 25 kg. of rice husk per hour has been selected. Being the first of its kind, certain assumptions have to be made. But the prototype unit has inbuilt flexibilities to vary the operating parameters such as temperature, rotational speed of the gasifier, feed rate, and the amount of steam to be injected during pyrolysis. Further, a similar equipment is available in the Chemical Engineering Department of University of the Philippines,^{SO} many of the mechanical components could be duplicated. This equipment is however being used for roasting of ores. The flow-sheet of the gasifier system is given in Fig. 5.2.

5.5 Process Design Parameters

A. The raw material - rice hull has the following typical composition:

Moisture	10%
Volatile Matter	65%
Fixed Carbon	15%
Ash	20%
Heating Value = 3000 Kcal/kg. or 5,400 BTU/lb.	

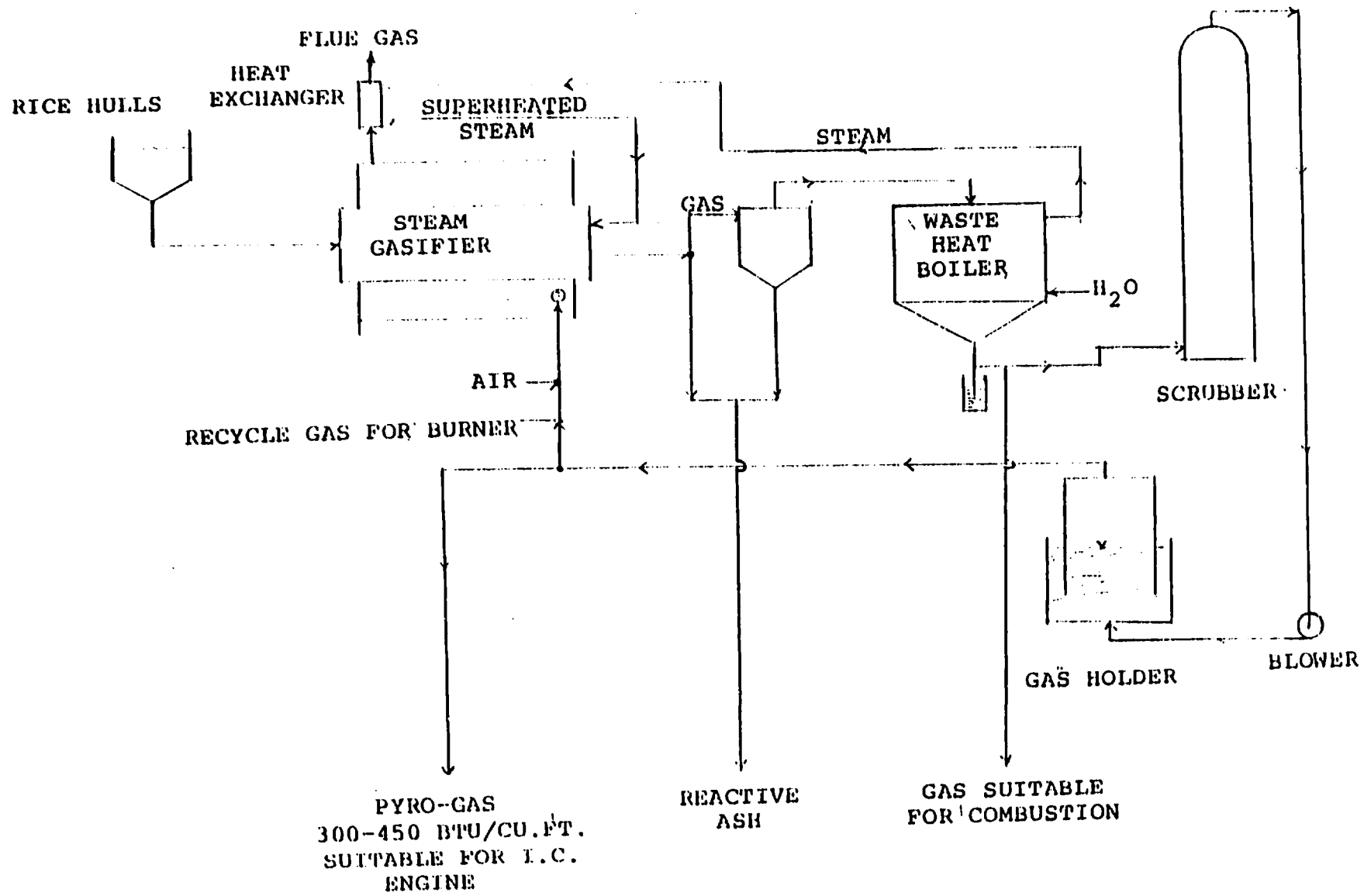

FIG. 5.2 STEAM PYROLYSIS - CUM GASIFICATION OF RICE HULLS

The gas produced will vary in composition depending upon the operating parameters, but the typical composition assumed is not impracticable to achieve. In fact gases with higher heating values than that given below can be produced.

B. Gas Composition (by volume)

CO = 35%	Mol. Wt. = 26.5
CO ₂ = 30%	Density = 0.00118 kg/liter
CH ₄ = 20%	or
H ₂ = 15%	Specific = 845 liters/kg Volume (at N.T.P.)
Higher Heating Value = 3,859 KCal/Cu. meter	
	= 433 BTU/ Cu.ft.
	= 3,262 KCal/kg.

It is possible to achieve the following material balance which has been calculated on the basis of the elemental analysis of rice hull. Yields better than those shown below can be obtained.

C. 1 Kg. of Rice Hull plus 0.1 kg. of Steam Should Yield

Gases	=	0.65 kg.
Liquid (water)	=	0.20 kg.
Tar, etc.	=	0.05 kg.
Ash	=	<u>0.20 kg.</u>
Total	=	1.10 kg.

The total amounts to 1.10 kg. and additional amount is due to the water gas shift reaction.

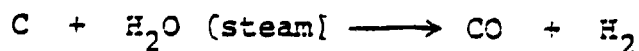

- 31,690 KCal/kg.mole.

While all the gases could be recovered, one would expect some losses of other products.

Based on 1 kg. of rice husk, having a heating value of 3000 KCal/kg., the energy balance obtained is:

D. Energy Input = 3000 KCal.
Energy Output = (KCal.)

<u>PRODUCT</u>	<u>YIELD</u>	<u>ENERGY LOST</u>	<u>ENERGY AVAILABLE</u>
Gas	0.65	193*	2145
Water (steam)	0.20	175**	-
Tar	0.05	447***	-
Ash	0.20	50*	-

E. Energy Required for Gasification

Once the process has been brought to steady state and the equipment, that is, gasifier body and furnace have been heated up, the heat will be required for heating the raw material, drying, pyrolysis, gasification, heating the steam, and for water-gas shift reaction.

- * Sensible heat
- ** Latent and sensible heat
- *** Also includes the heating value of tar as 8330 KCal/kg.

Break-up of the heat required for gasification at 650°C. (Basis: 1 Kg. of Rice Hull):

1. Sensible heat for heating the raw material = 248 KCal.
 2. Drying of rice hulls = 60 KCal.
 3. Endothermic steam/carbon reaction = 200 KCal.
 4. Sensible heat required to superheat 0.5 kg. of steam from 200-650°C = 102 KCal.
- 610 KCal.

Taking heat losses in the furnace, mainly with the flue gases, 65% combustion efficiency can be obtained with proper design of the furnace.

Taking 65% Efficiency

Heat Required for Gasification = 938 KCal.

In the above analysis, the heat of pyrolysis which in fact is exothermic and partial combustion that might take place due to small influx of air are neglected.

F. Amount of Gas Available

For one kg. of rice hull gasified, (CV = 3600 KCal/kg.) 2145 KCal of energy is available in 0.65 kg. of gas produced. Out of this 0.284 kg. of gas having heat content of 938 KCal has to be used for gasification leaving a net quantity of gas of the order of 0.336 kg. having a heat content of 1207 KCal.

This amounts to that the present system is 40% energy efficient. Although the efficiency is not that high, it has two major compensating factors

- 1) The calorific value of the gas is about three times higher than that produced by partial oxidation and
- 2) the most important is that, it generates about 0.2 kg. of amorphous reactive silica which can be converted into value added products such as silicates as building materials and as fillers in rubber and plastic moulding industries. The ash obtained is considered to be relatively free of unburnt carbon such that it will not impare the colour and quality of plastic and rubber goods. Other uses can also be found for this important reactive materials having high surface area.

One important factor that will influence the production and quality of gas is the amount of steam injected during pyrolysis. This important operating parameter has been kept very flexible in the design so that the net production of gas and the quality of silica obtained can be optimized.

At the capacity envisaged for the prototype unit of 25 kg. of rice hull per hour, it could produce about 10.5 kw. of electrical power (14 BHP) taking 30% overall efficiency of I. C. engine.

Chatterjee⁽³⁾ has identified at least 16 Top Rice Millers which are producing rice hulls more than 2 MT/day ranging from 2.4 to 16.6 MT per day.

Rice Millers producing about 10 tons/day are very common in some of the LDC countries including the Philippines and India. Such a unit can produce 2 MT of ash and 175 kw. of electrical power (235 BHP) which is more than sufficient for running a rice mill and cement grinding integrated plant as shown in Fig. 5.1.

5.6 Mechanical Design of the Gasifier

A. Based on the capacity of 25 kg/hr., the overall specifications of the rotary gasifier are:

Internal diameter	=	8" (200 mm)
Recommended thickness	=	1/2" (12.5 mm)
Length	=	10 ft. (3048 mm)
Thickness of the material inside the gasifier at the inlet	=	max. 3" (76 mm)
Width of the material at the inlet	=	7.74" (196 mm)

Based on the flow rate of rice hull, the residence time of the material = 21.2 minutes

At the inlet, the cross-sectional area occupied by rice hulls is 17.95 sq. inch (116 sq. cm.) compared to cross-sectional area of the gasifier equal to 50.26 sq. inch (325 sq. cm.) leaving an open area of 64%. This loading is appropriate for rotary type of calciner or gasifier.

B. Material of Construction

The recommended material for gasifier is stainless steel AISI 310 containing 25% chromium and 20% nickel. This is recommended because of high chromium content to avoid excessive oxidative corrosion on the outside surface of the gasifier.

Normally, no corrosion is expected within the gasifier. This gasifier as shown in Drawing 5.3, is further mechanically reinforced with compensating rings and longitudinal strips, the latter will also increase the surface area for heat transfer.

C. Internal Details of the Gasifier

The gasifier is divided into four zones. Starting from feed inlet side, the first zone is mainly for drying the material, the second zone is for pyrolysis - cum gasification, third zone is for physically breaking the structure of the char to liberate carbon from the cellular carbon-ash structure and the fourth zone, which is the hottest is designed to crack the high molecular gases and tars and also for gasification. Except in the drying section, superheated steam is injected in the reactor.

Except in the zone three, lifter are provided inside the reactor to have thorough mixing of material and also offer more surface area for reaction - Gasification. The velocity of gas and unreacted steam

leaving the reactor is calculated as 0.35 m/sec. which is not large enough to pneumatically carry the rice husk or solids through the exit. However, a cyclone separator is provided to remove the solids before these enter the heat exchanger (waste heat boiler). For grinding of char 8, 12.5 mm diameter and 60 mm long rods have been incorporated in the zone-three of the reactor.

The reactor has been provided with two mechanical seals, two bellow joints to take care of expansion and two independent motor variable drive for gasifier body and also for the screw feeder. This complete structure is hinged on the discharge side and the lifting screw on the other side to change the inclination of the gasifier from 6-18 mm per foot (300 mm) of the gasifier length have been provided.

The rotational speed of the gasifier can be varied from 3.5 to 35 rpm. Both the gasifier and feed screw are driven by chain drives with idlers for adjustment.

5.7 Heat Transfer Characteristics and Furnace Design

Normally, for indirect fired rotary dryers/kiln/gasifier, the major considerations are on the strength and the corrosion characteristics of the material. However, to have effective heat transfer and proper thermal efficiency of the furnace, sufficient area for heat-transfer and proper flow path for Flue Gases respectively must be provided. Normally for gas fired backmixed type burner

with furnace, $2,460 \text{ BTU/hr.ft}^2$ rating should be sufficient. But in the present case a rating of $1,625 \text{ BTU/hr.-sq. ft.}$ has been provided by having a heat transfer area of about $37.2 \text{ sq. ft. (3.45 m}^2\text{)}$.

The furnace has been divided into five zones with baffles to have five passes for the flue gases to have sufficient residence time for the flue gases to transfer heat and also to improve the heat transfer coefficients. The furnace is well lagged to avoid excessive heat losses. The exit flue gas temperature is expected to be around 300°C .

5.8 Auxiliary Equipment

A. Feed Hopper

The feed hopper made of M.S. is having a capacity of about 25 kg of rice husk so that once in an hour the feed can be manually added. The screw feeder is so designed that it will feed the material and also act as an airlock feeder. The feeder can be run by a variable drive of 1/2 HP motor. The speed should be varied from 1 rpm to 20 rpm with an independent drive.

B. Dry Gas Cleaning System

At the outlet of the gasifier, two openings have been provided. At bottom, for the ash to be removed through 75 mm pipe by gravity and at the top a 2-1/2" (62.5 mm) M.S. pipe. The pipe leads the gases to a hot dry gas cyclone separator. The velocity in the pipe has been kept at about 35 ft/sec. (11 m/sec.).

A 15 cm diameter cyclone with standard dimensions and inlet velocity of 45 ft/sec. has been provided to remove the entrained solids. All the outlet gas lines from gasifier to the cooler - gas cleaning and waste heat boiler including the cyclone body should be properly insulated to avoid any condensation of tar and moisture. During the start up these units should be heated by passing flue gases to heat it up to 300°C and gases being produced should be by-passed. Once

tar condenses the efficiency of separation will be considerably reduced. The gases leaving the cyclone are expected to be at the temperature of 500°C. These consists of 0.65 kg of gases and 0.5 kg of steam per kg. of rice hull gasified during the steady state operation of the gasifier at 650°C.

Wet-Gas Cleaning and Waste Heat Boiler System

After cyclone separator, the hot gases and steam are passed through gas cooler-scrubbing and condenser units. About 3 times more than theoretically calculated heat transfer area has been provided to take care of extra capacity that might be obtained during the operation. The gases are passed through 14 tubes of 2.5 cm. I.D. over which hot water is circulated. The gases are cooled to 200-150°C in the first cooler and then scrubbed in a spray tower of 22.5 cm diameter and 130 cm high. The steam so produced is condensed in the secondary condenser. All the water/gas con-

densed are taken to a water seal which also acts as safety device during any mishap. This arrangement is given in the fabrication drawing as shown in Fig. 5.4. The gas is finally passed through an ordinary ss wirewoven demister before going to the blower.

D. Gas Blower

The function of the blower is to remove the gases from the gasifier and the gas cleaning system and store these in a gas holder. The gasifier is expected to function at slightly above atmospheric pressure and the pressure drop through the gas cleaning system is expected to be of the order of 8-10 inches (20-25 cm) of water gauge. But to avoid the need to have another blower for taking the gases to the gasifier furnace, the gases in the gas holder should be stored at 3 ft. (100 cm) of water gauge.

The production of gas under steady state is about 11.0 cu. ft./min or 18.7 m³/hr. at about 60°C.

Taking into consideration the increased production that may be expected, it is recommended that a blower of the following specifications may be incorporated.

Capacity: 55-60 cu.ft./min at 30°C
(90 - 100 M³/hr.)

Pressure: 5 lb/in² gauge (0.33 kg/cm²)

For this purpose, a positive displacement rotary roots type blower with external lubrication will be most suitable.

It should be installed with a by-pass line so that the discharge rate and the required pressure can be regulated through by-pass valve.

E. Gas Holder

A capacity of 1,000 cu.ft. (28 M^3) is envisaged for the gas holder which will hold about 24 kg of gas. The gas can be filled by operating the gasifier for 2.5 hours (gas generation rate of 0.37 kg/kg of rice hull gasified) at the rated capacity of 25 kg of rice hull per hour. The overall dimension of the floating head of gas holder are 16 ft (4.87 m) diameter and 12 ft (3.65 m) overall height with a water seal of 7 ft (2.13 m). The shell made of 4 mm M.S. sheet will produce a pressure of 0.19 lb/in^2 or 6.5 ft. (1.98 m) of water gauge. The capacity of this gas holder can be increased by having counter weights for lifting the dome. Alternately if the cost of this holder is rather high, the capacity can be reduced by 50%.

F. Gas Burner

A backmix type gas burner of capable of burning 0.24 kg/min. of gas (twice the rated capacity) having a specific volume of 0.845 m^3 per kg and a calorific value of 350-400 BTU/ft³ or 3,115 - 3,560 k-cal/m³ is recommended. The gas is available at a pressure of about 1 meter water gauge. A suitable blower to give 1.2 - 1.5 excess air than that theoretically required should be provided along with the burner. The theoretically

air required is about 3.73 kg of air per kg of gas burnt. The gas burner should be so located that the flame should not impinge on the outside surface of the metal shell of the gasifier. Further it is recommended that the discharge side outer surface of the gasifier should be covered with 2 cm layer of heat transfer cement to prevent its overheating and also to protect it from excessive high temperature oxidative corrosion.

G. Gas Flare Unit and Purging

During the start up, it is recommended that the gases produced should not be passed through the gas cleaning system and the gas holder. These should be by-passed and flared in a standard flare pipe type system. At the same time the gas cleaning system should be warmed up to 250-300°C by passing the flue gases through the gas cleaning system. The line should then be purged with superheated steam available before allowing the combustible gases into the gas holder system.

6. RECOMMENDATIONS

1. After incorporating minor modifications and instrumenting the two ton per day converter installed at ERDC, extended period trial runs should be undertaken to test its reliability and obtain suitable data for calculating material and energy balances and rate of production.
2. Without carrying out any major modifications, trial runs should also be performed on the above converter with materials other than rice hull such as peanut shells, sawdust and broken coconut shell.
3. After studying the performance of the above unit, major modifications may be incorporated to have trial runs with coconut shell and lumped coconut husk. In its present form, the unit is not suitable for pyrolyzing unbroken coconut shell.
4. Before a new raw material is tried in the above pyrolyzer, it is recommended that the same material should be first pyrolyzed in bench scale pyrolyzer. The bench scale pyrolyzer should be fabricated as per drawings provided in this report. The bench scale operation will give data about the yields and physical characteristics of the char.

5. The char produced from low ash material could be briquetted and its combustion characteristics analyzed and relatively compared with coconut shell charcoal. The briquetted fuel could also be a potential raw material for gasification in a conventional gasifier being manufactured in the Philippines.
6. The tar obtained should be modified and tested for its potential use as preventive coatings and as wood preservative. Also, its combustion characteristics should be tested in the boiler available at ERDC.
7. Three designs of modified drum charring units be analytically tested. 8-10 drums of most suitable size should be installed in the field to produce charcoal from coconut shell and lumped coconut husk. Feedback be obtained about their operating life after these have been given preventive coatings of washed tar. This low technology unit has great potentials of its usage by small farmers.
8. Two mobile kilns should be purchased modified by giving protective coatings and steps taken to get these installed in the field according to the mechanism proposed in this report. Since this unit has no moving parts and production rate is adequate, it will

find widespread application for commercial production of charcoal.

9. One reverse flow stationary kiln should be purchased, modified as per suggestions given in the report and be installed in the field integrated with a processing industries. The mechanism of transfer and the special qualifications of the recipients have been incorporated in the report.
10. Based on the operational experience gained on 2 ton/day converter installed at ERDC, the design drawings of 4 ton per day pyrolytic converter should be thoroughly examined. This unit can then be fabricated and be installed in the field as per recommendations contained in this report.
11. Steps can be taken immediately to procure hardwares, fabricate and install one 25 kg. per hour prototype rice husk gasifier system at ERDC.

12. To produce charcoal from small sized biomass materials such as ricehusk, shredded rice straw, sawdust, coir waste and bagasse, I.I.T Delhi Technology seems most appropriate. Before this technology is recommended, it is suggested that a senior engineer from the Philippines should visit India and study the performance of such units already commercialized. After studying its performance, the steps may be taken to procure this technology.
13. The Director Genral of International Rice Research Institute has shown keen interest in setting up a converter based on rice hull and straw. Steps may be taken to set one such appropriate unit either converter or gasifier in the field demonstration area of IRRI.
14. I.I.T Delhi community type kiln can be installed at ERDC premises for testing, for which I.I.T Delhi shall be pleased to supply the fabrication drawings.
15. Rice husk-gas stove should be fabricated and tested for its performance at ERDC. Design and drawings for such a unit has been incorporated.

7. ACKNOWLEDGEMENT

The author wishes to record his appreciation to all members of the Energy Research and Development Centre of the Philippine National Oil Company for their very kind hospitality and excellent cooperation in arranging visits to the provinces and valuable discussions with Officers of ERDC and other Government agencies.

REFERENCES

- 1) Report. UNIDO and/or operational co-operation projects in the Republic of the Philippines - 0057Q-821231 p. 28-29
- 2) Report. "Spectrum of Coconut Products" Philippine Coconut Authority - Don Mariano Marcos Avenue, Diliman, Quezon City, Metro Manila p. 6
- 3) Anil K. Chatterjee. Technical Report UNIDO DP/ID - /SER A/397 11 March 1983
- 4) John W. Tatom. Technical Report. UNIDO DP/ID/SER A/434
- 5) John W. Tatom. Trip Report for period 1 February 1983-6 April 1983
- 6) Edgar M. Medrano and Enrique C. Amio. Technological Assistance and Training Service Forest Product Research and Industrial Development Commission Los Baños, Philippines
- 7) Prem D. Grover. "Briquetted Fuel (PARU) from Agricultural and Forest Residues" paper presented 1st Conference on Producer Gas. Indian Society for Agricultural Engineers India International Centre New Delhi. December 1981
- 8) Prem D. Grover. "Briquetted Fuel (PARU)" Technical Report. Indian Institute of Technology, New Delhi 110016. India
- 9) Prem D. Grover "Briquetted Fuel (PARU)" Mechanised - Feasibility Report. Indian Institute of Technology, New Delhi. 110016. India
- 10) P. K. Menta and N. Pitt. Energy and Industrial Materials from Crop Residues. Resource Recovery and Conservation 2 (1976) 23-28

ANNEXURE - I

- 70 -

Comparison of availability of different wastes by region.

Region	Bagasse	Rice hull	Coco-nut husk	Banana pseudo-stems	Wood waste from Logging For. ind.	
	1000 dry tons					
1. Ilocos		107	20	-	49	18
2. Cagayan Valley	13	125	3	-	370	146
3. Central Luzon		229	1	-	3	19
4. Southern Tagalog	-	132	1077	-	89	22
5. Bicol	78	107	213	-	28	4
6. Western Visayas	144	205	93	-	39	23
7. Central Visayas	246	41	207	-	-	-
8. Eastern Visayas	54	57	237	-	100	12
9. Western Mindanao		51	305	-	219	51
10. Northern Mindanao	9	55	247	-	454	195
11. Southern Mindanao		33	787	36	616	309
12. Central Mindanao		122		-	194	121
	544	1315	3195	36	2211	920

ANNEXURE - II

PHILIPPINE COCONUT SHELL SUPPLY UTILIZATION
AND AVAILABILITIES
(In 000 shell pairs)

Period	Shell Production ^{1/}	LESS Fuel & Other Uses ^{2/}	Availa- bilities ^{3/}	ECONOMIC UTILIZATION				Implied Shells Wasted ^{8/}	
				Charcoal ^{4/}	Shell Flour ^{5/}	Cottage products ^{6/}	Shell Exports ^{7/}		Total
1973	8,423,680	5,865,217	2,558,463	553,605	28,594	21,120		603,319	1,955,14
1974	6,411,180	4,741,656	1,669,524	820,770	39,203	39,228		899,201	770,24
1975	9,896,180	6,440,732	3,455,448	595,110	38,700	79,707		513,597	2,941,85
1976	12,347,330	7,987,692	4,359,638	675,480	39,120	43,279		757,879	3,601,75
1977	10,983,450	7,728,519	3,254,931	672,420	39,574	19,879		731,873	2,523,05
1978	11,200,270	7,435,531	3,764,739	982,770	50,640	70,837		1,104,247	2,660,49
1979	9,767,450	4,777,205	4,990,245	1,511,940	51,428	11,679	72	1,575,119	3,415,12
1980	10,135,652	6,923,749	3,211,903	2,305,290	57,943	16,472	4,796	2,384,501	827,40
1981	13,249,248	9,544,059	3,705,189	2,070,900	65,111	23,061		2,159,072	1,546,11
1982	13,982,236*	8,501,330	5,480,906	1,712,750	72,000	25,713		1,810,463	3,670,44
TOTAL	106,396,676	69,945,690	36,450,986	11,901,035	483,393	351,055	4,868	12,539,351	23,911,63

* Preliminary

1/ Shell Production = nuts gathered

2/ Shells used as fuel in copra drying and in desiccated coconut processing + shells of nuts used for domestic nut consumption + shells of exported nuts.

3/ Col 1 - Col 2 = shells available

4/ Shells used in charcoal production (includes activated carbon & briquettes) converted at 15,000 shell pairs/MT charcoal

5/ Total shell flour production converted at 6,000 shell pairs/MT shell. Shells to shell flour is placed at 70% recovery.

6/ Estimated shells used for cottage - handicraft products

7/ Shell exports converted at 6,000 shell pairs/MT shells.

8/ Shells unaccounted for. Some of these shells can not be availed of as they are as far as 20 kms. away from passable trails.

Prepared by:

ESTHER B. PADALLA
Market Economist
Philippine Coconut Authority
Diliman, Quezon City

ANNEXURE - III



ANNEXURE IV

FABRICATION DRAWINGS

OF

STEAM GASIFIER

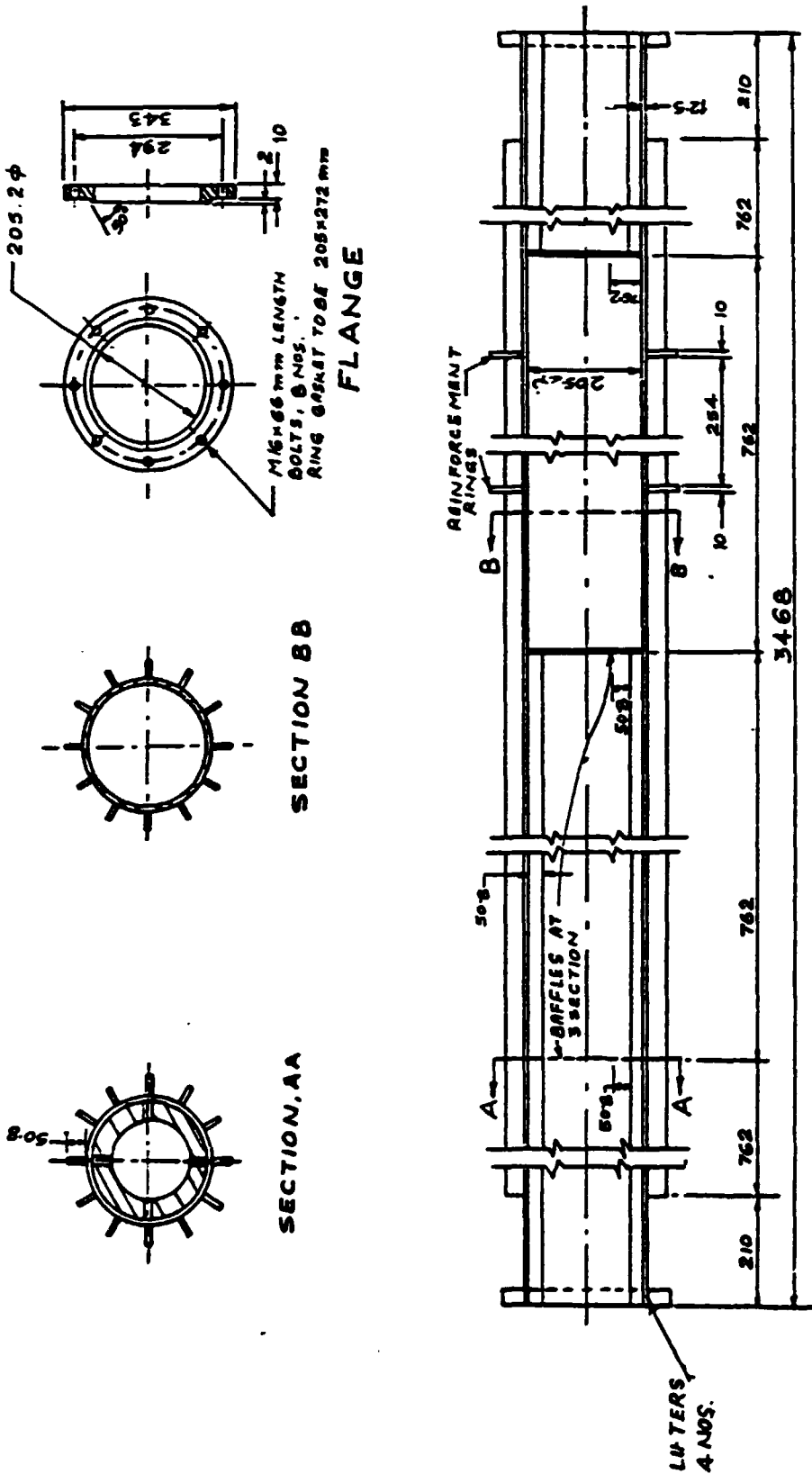

NOTE: - ALL DIMENSIONS IN MM.
- MNTL: STAINLESS STEEL 310

GASIFIER

FIG. 5.3

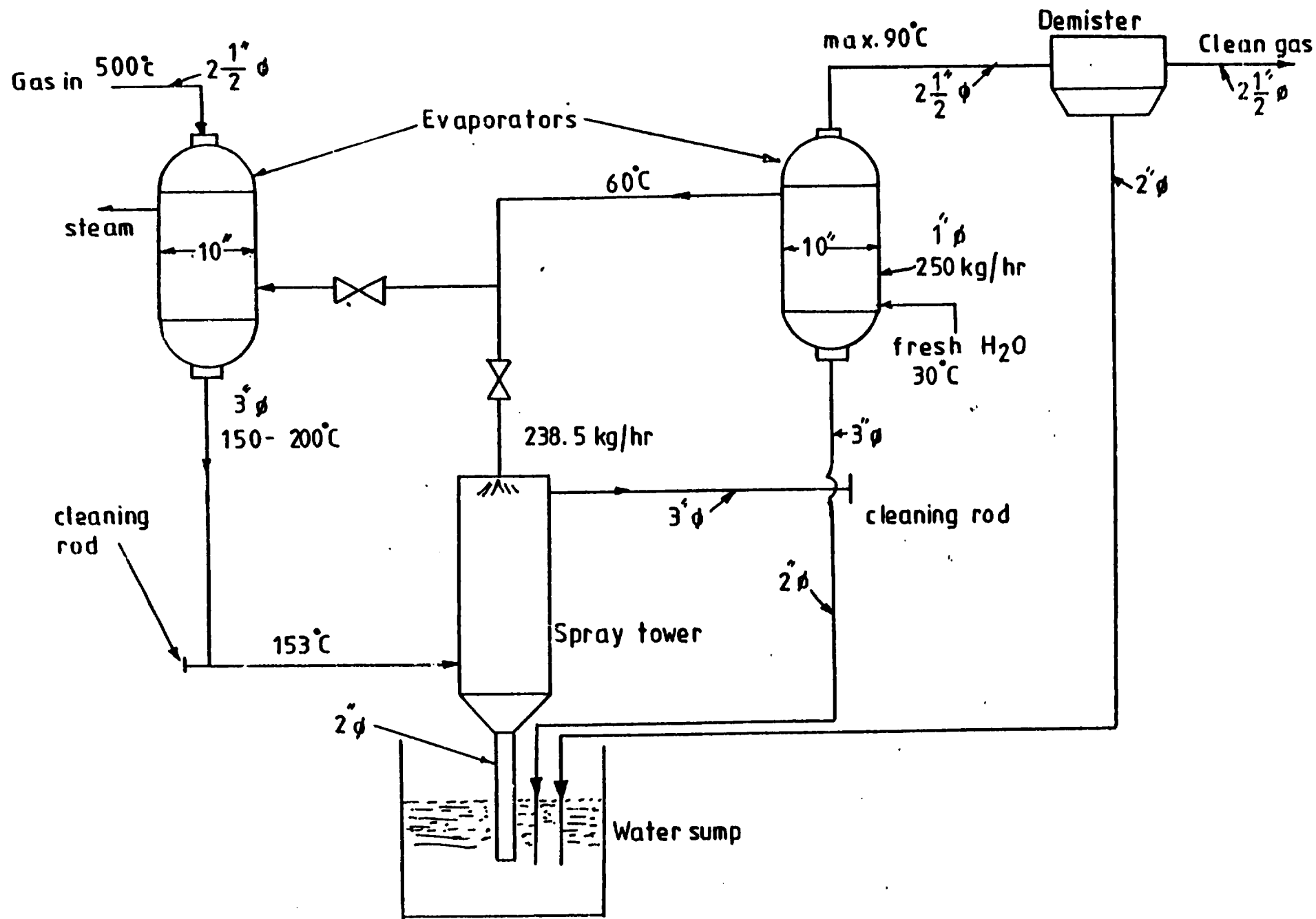
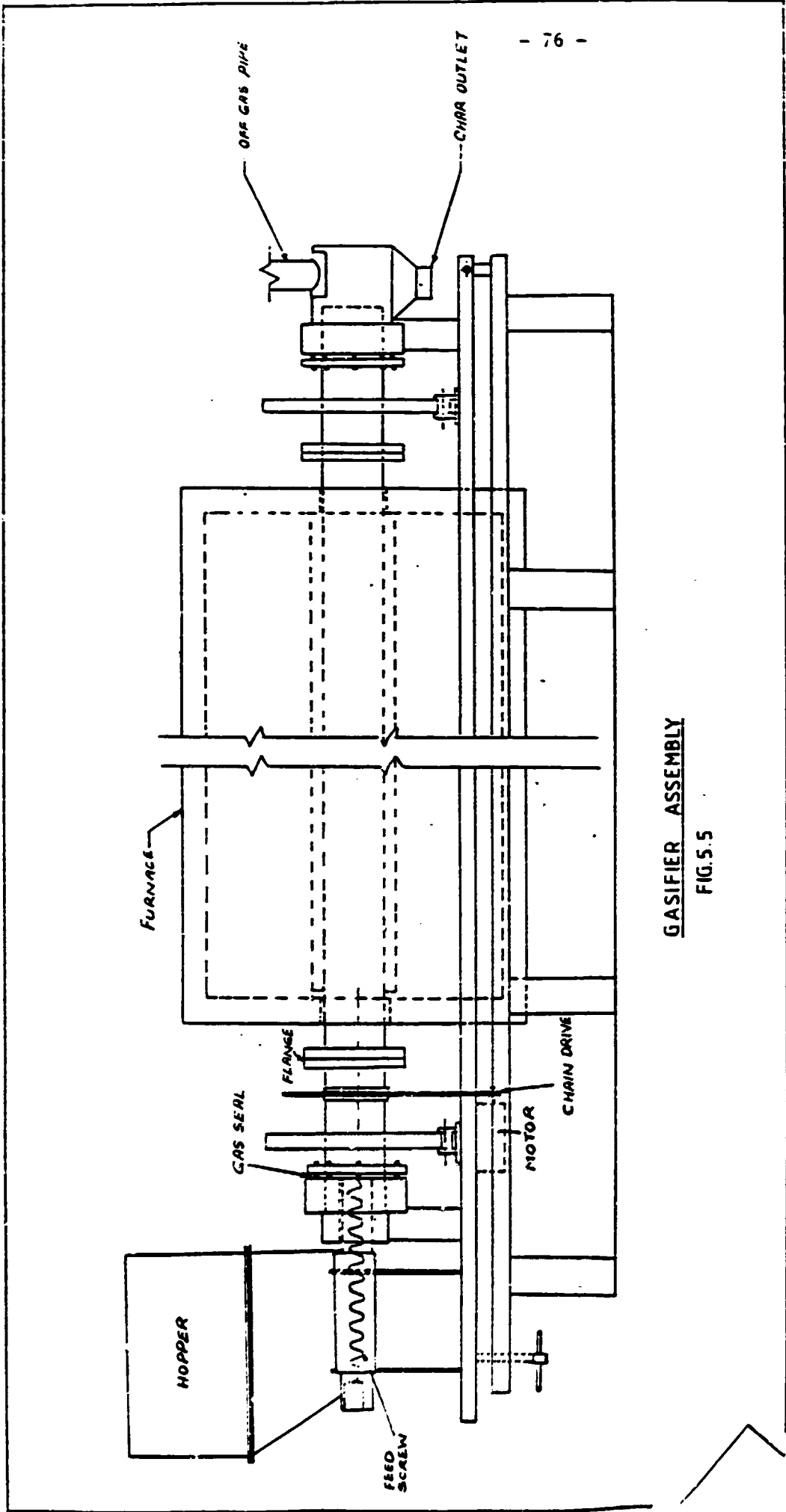
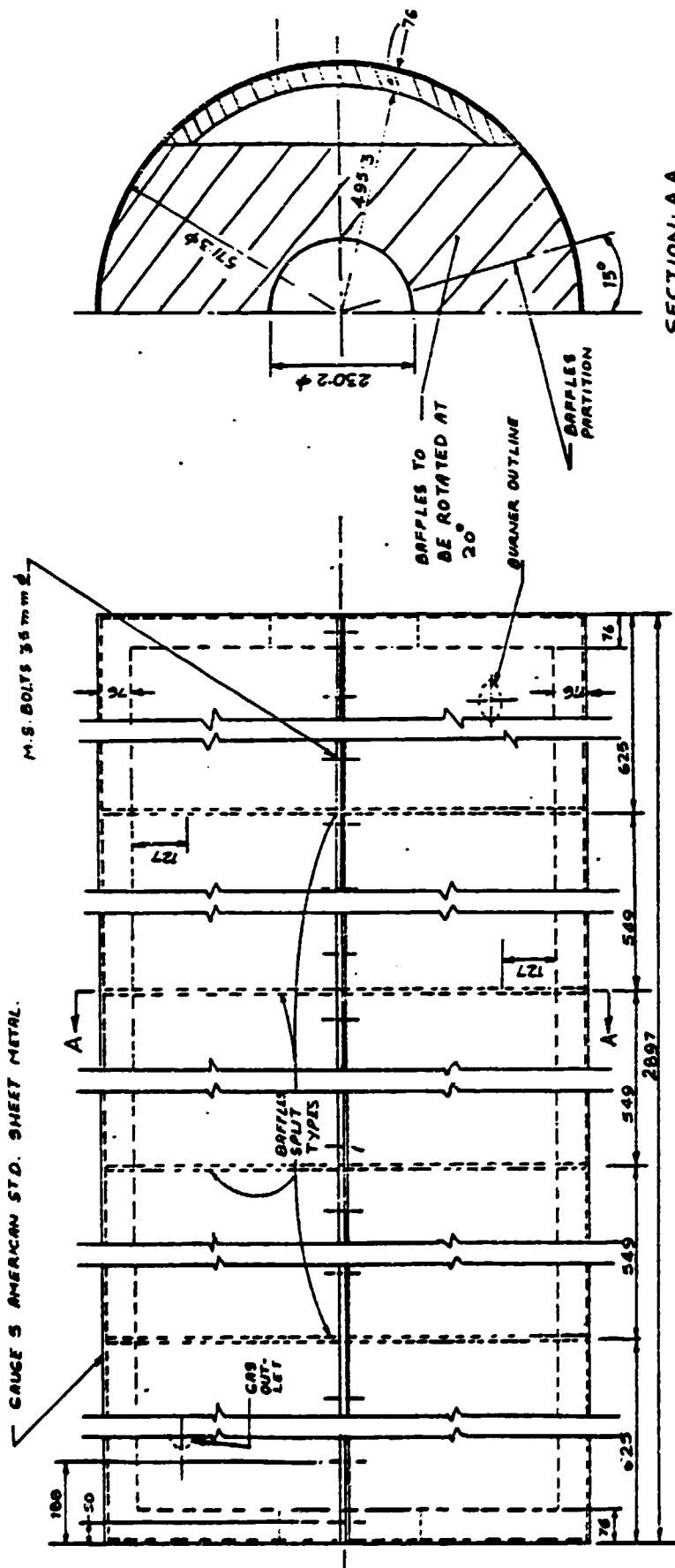

FIG.5.4: WET GAS CLEANING & WASTE HEAT BOILER SYSTEM



GASIFIER ASSEMBLY
FIG. 5.5



FURNACE

FIG 5.6

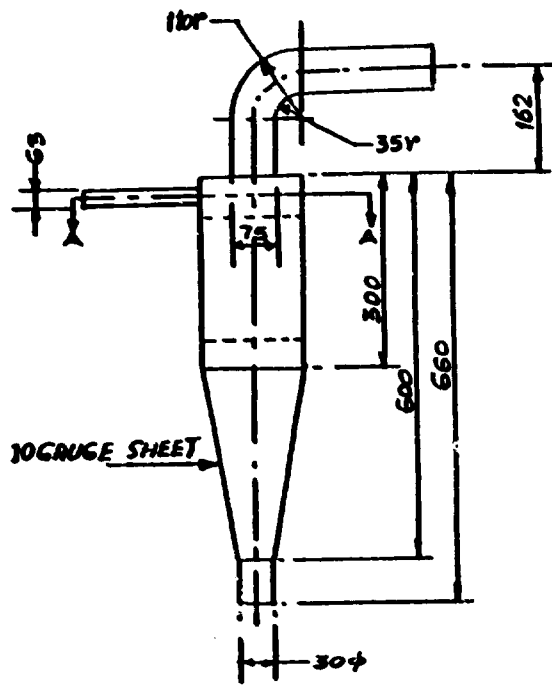

CYCLONE

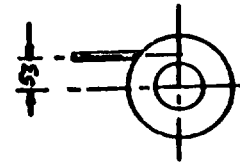

SECTION AA

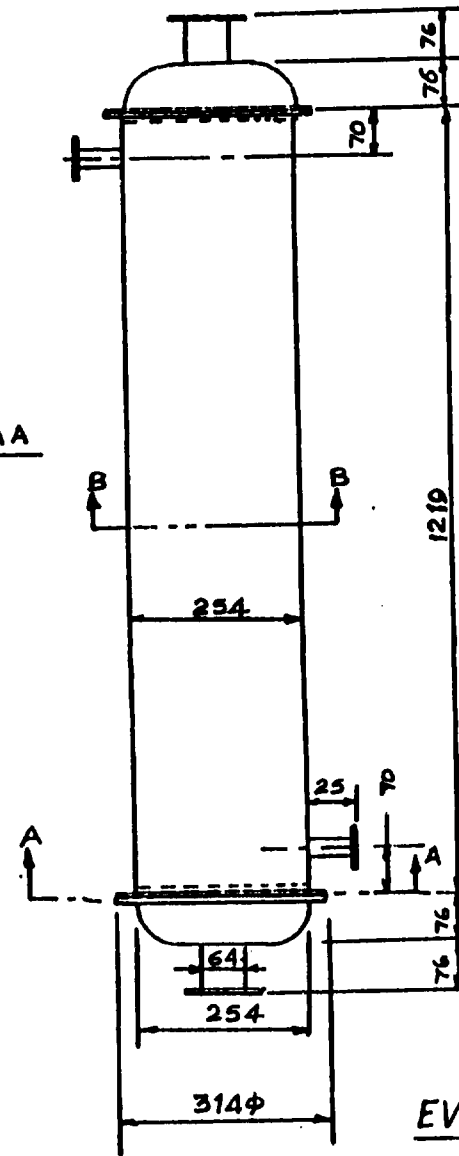

EVAPORATOR CONDENSER

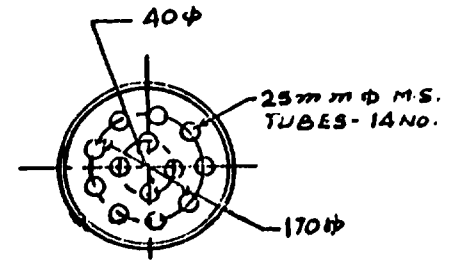

SECTION BB

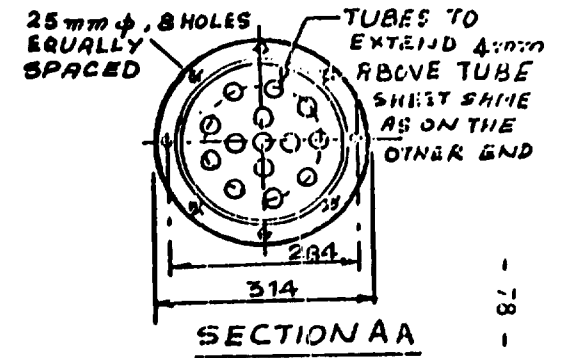

SECTION AA

NOTE:-
 - MATL:- MILD STEEL
 - ALL DIMENSION MM.

FIG. 5.7a

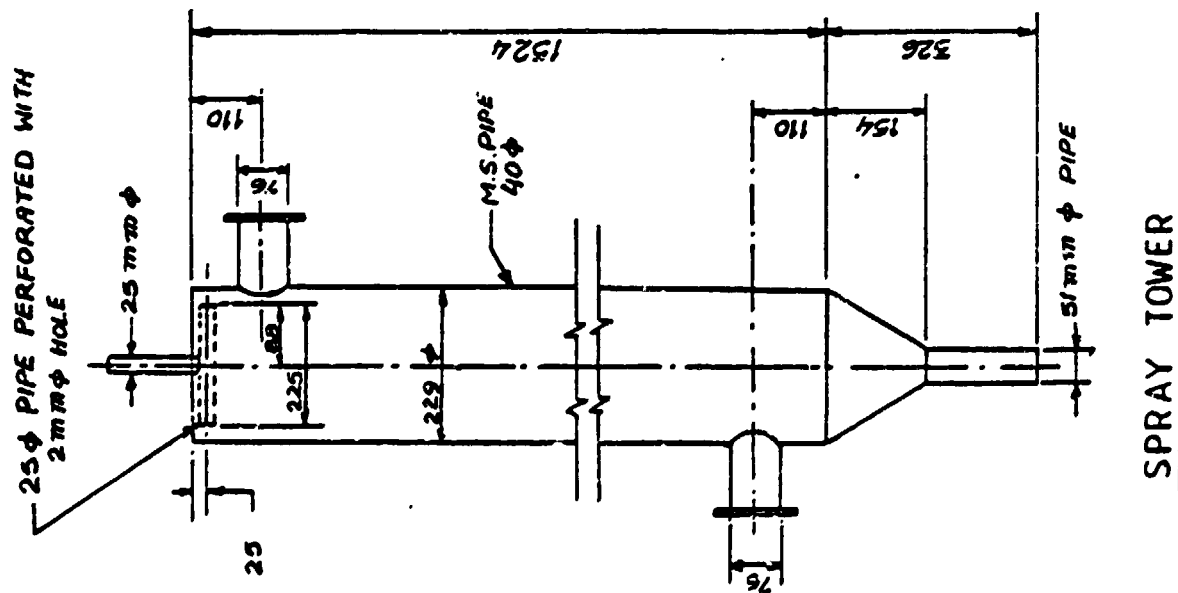

SPRAY TOWER

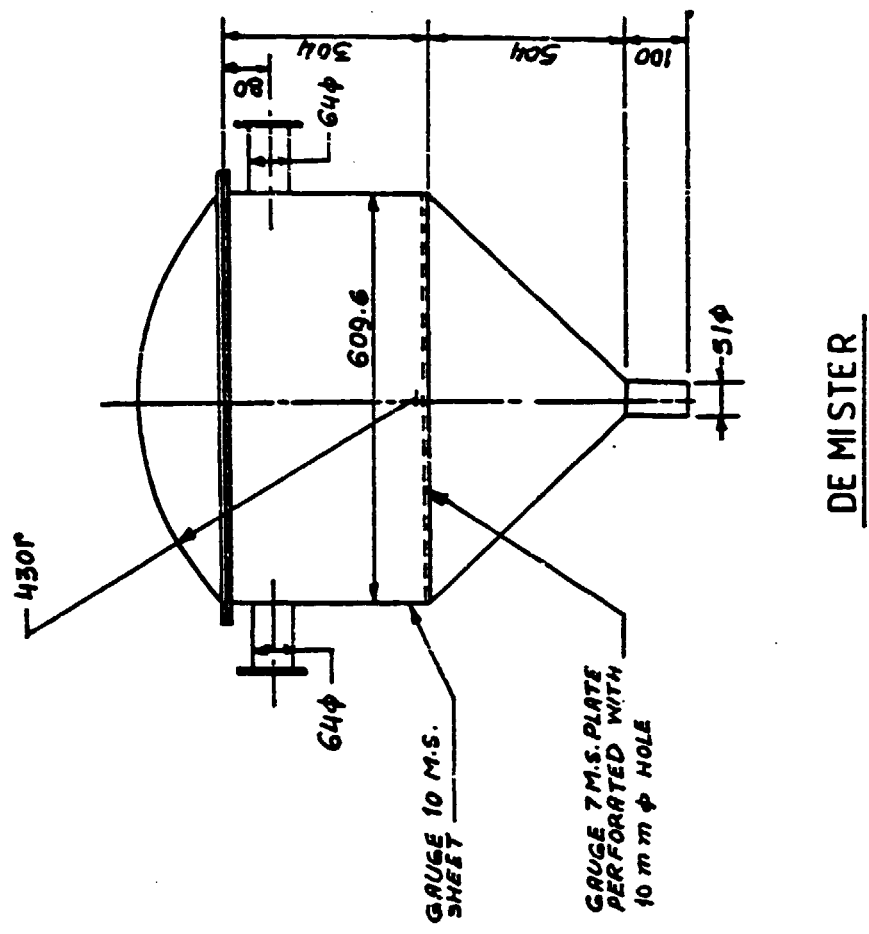

FIG. 5.7 b

ANNEXURE V

FABRICATION DRAWINGS

OF

BENCH SCALE PYROLYSER

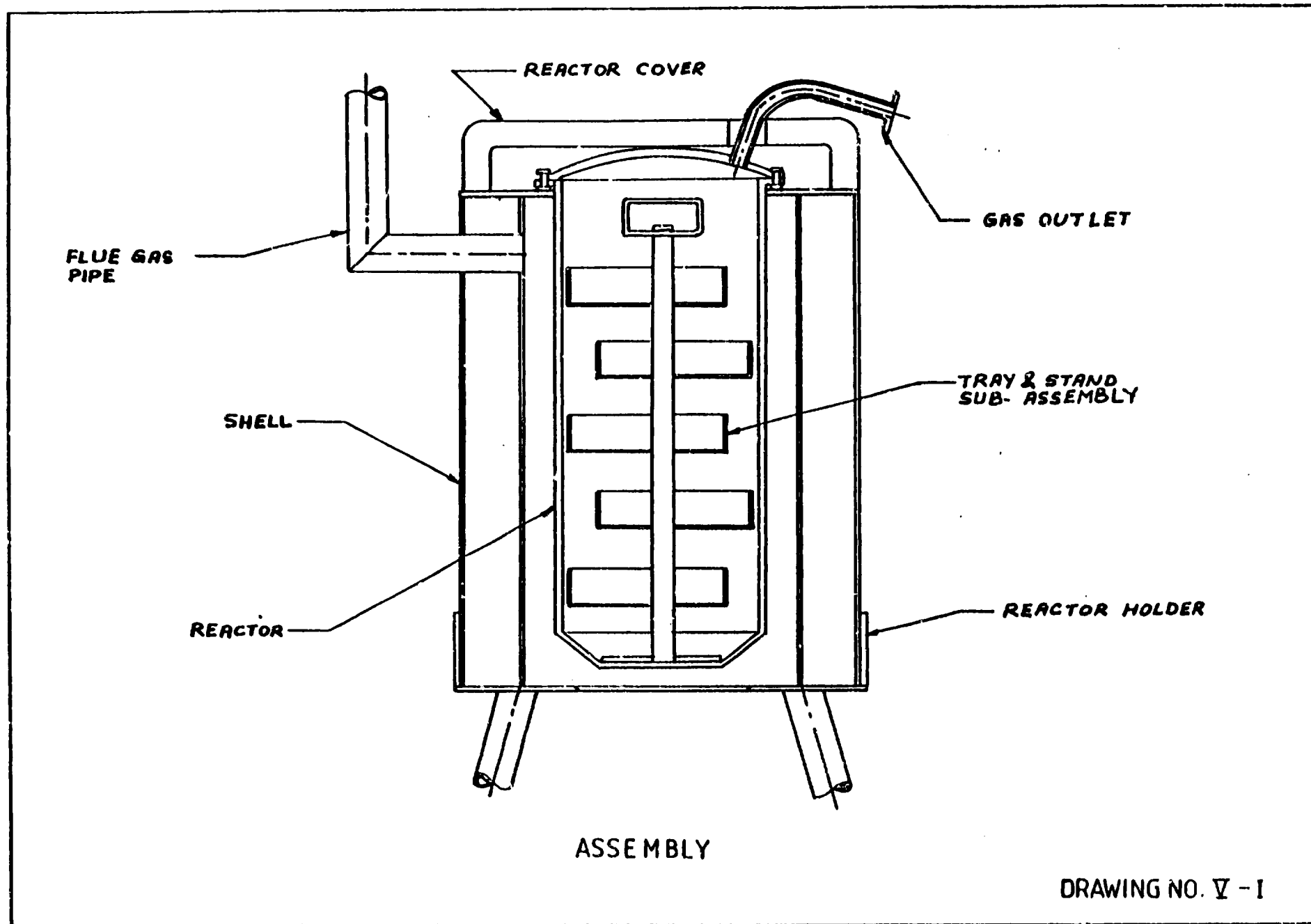

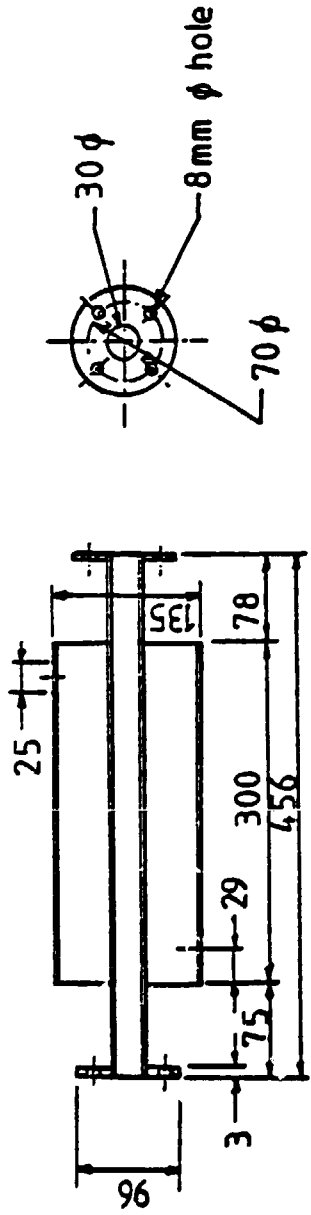

CONDENSER
Matl: M.S.

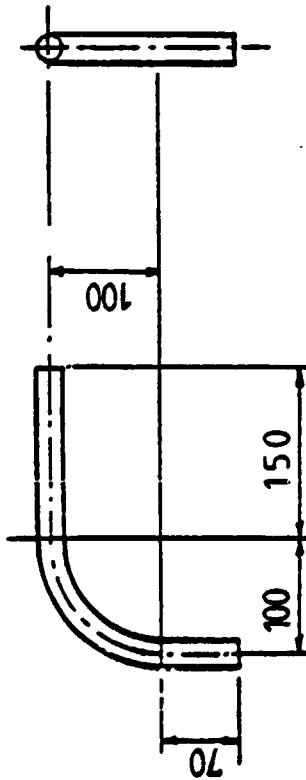

GAS OUTLET PIPE

Matl: 254 mm ϕ schedule 80 s.s. pipe

DRAWING NO. V-II

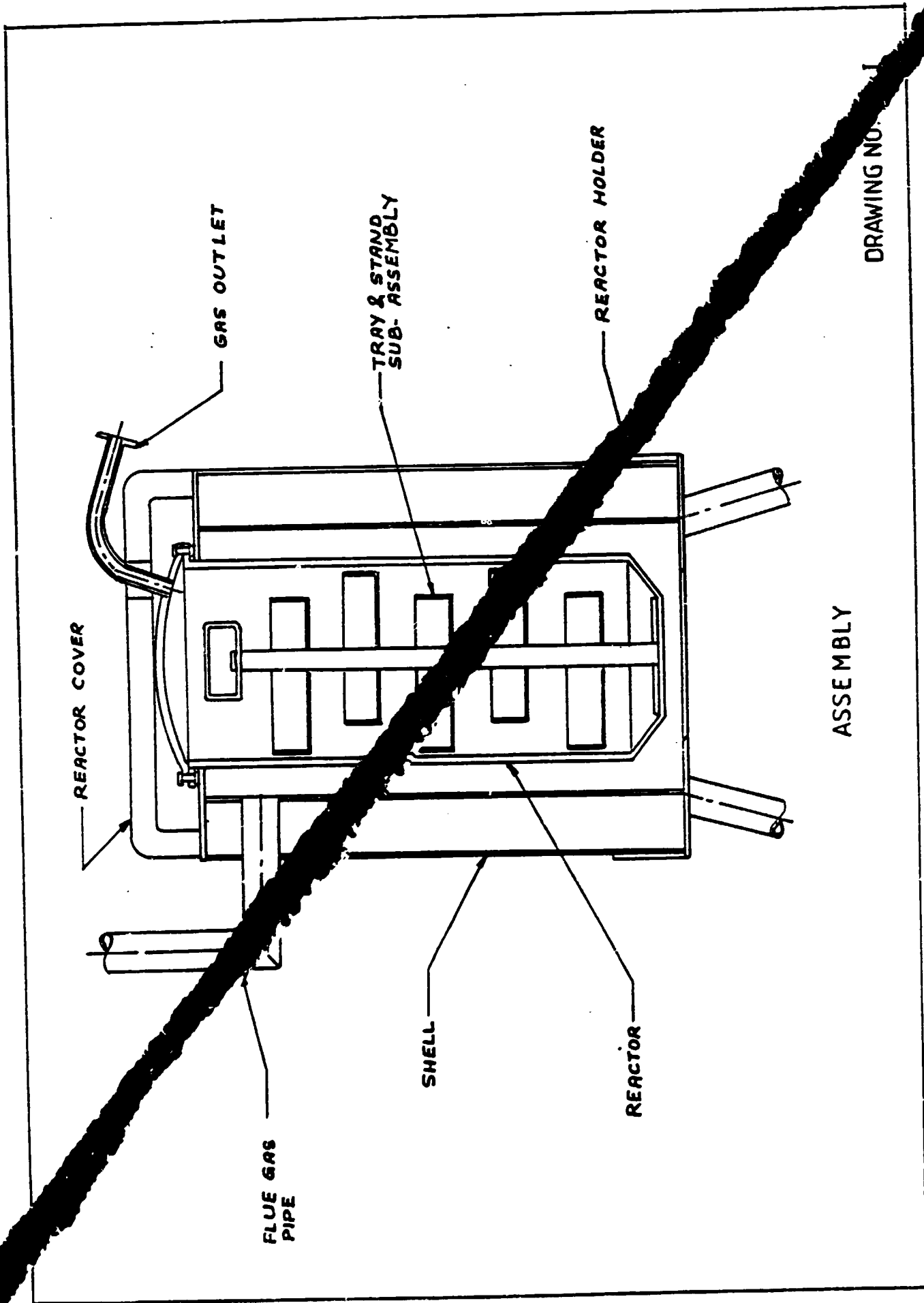

ASSEMBLY

DRAWING NO. 1

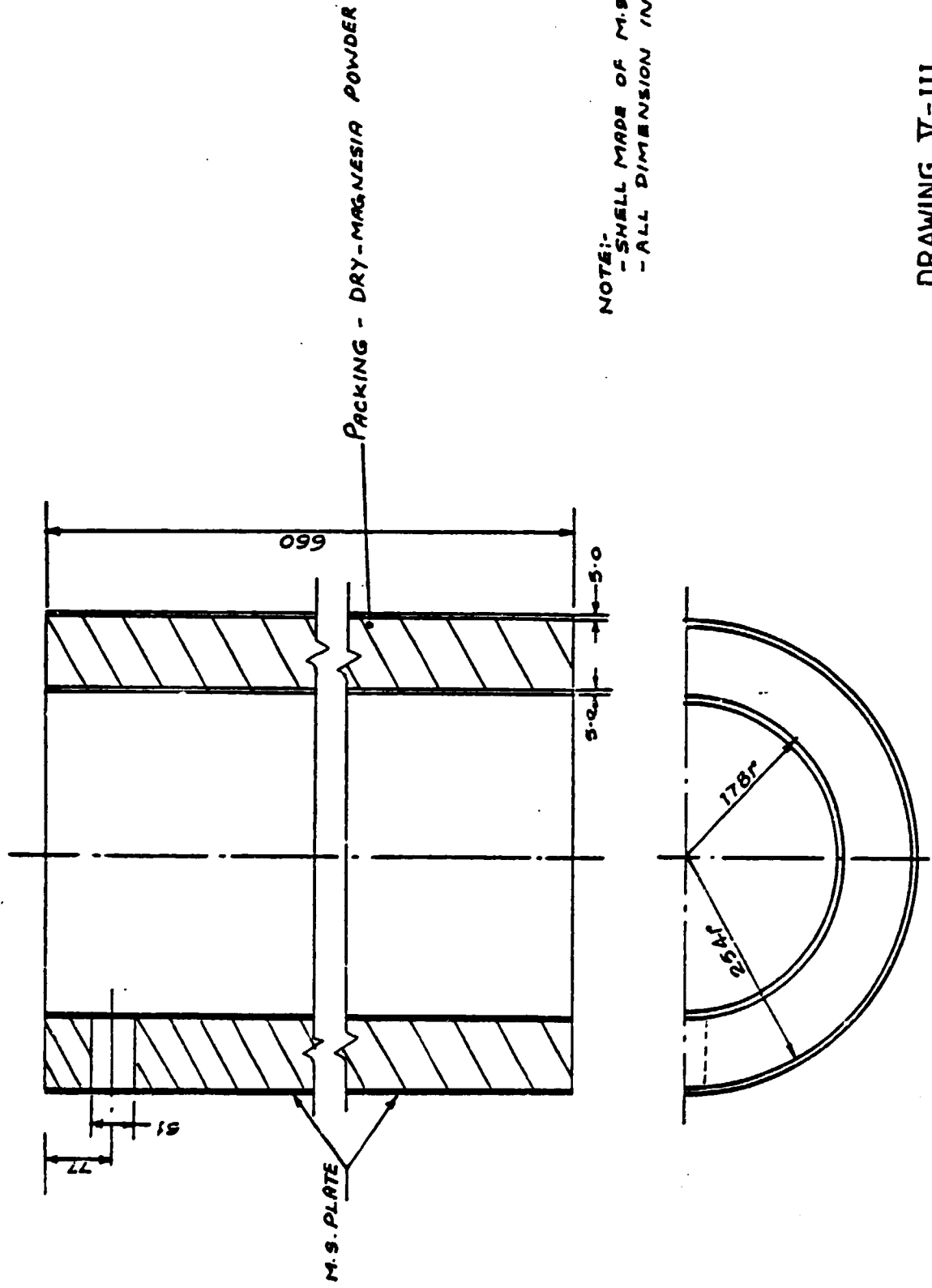

DRAWING V-III

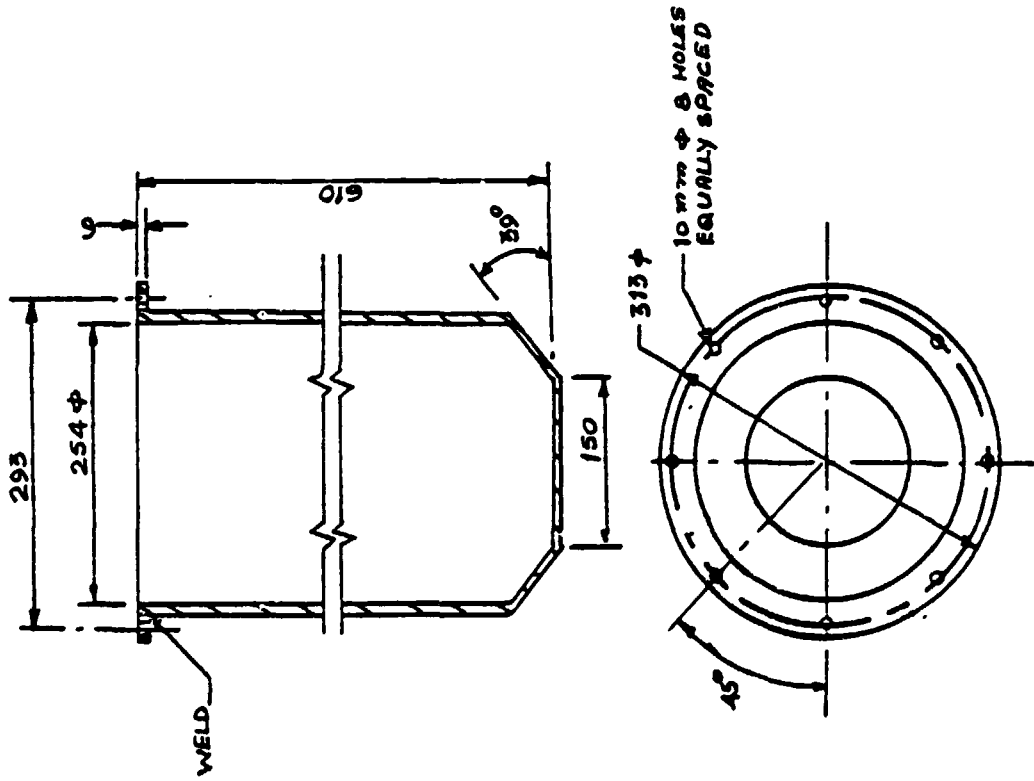

REACTOR
MRTL:- M.S.

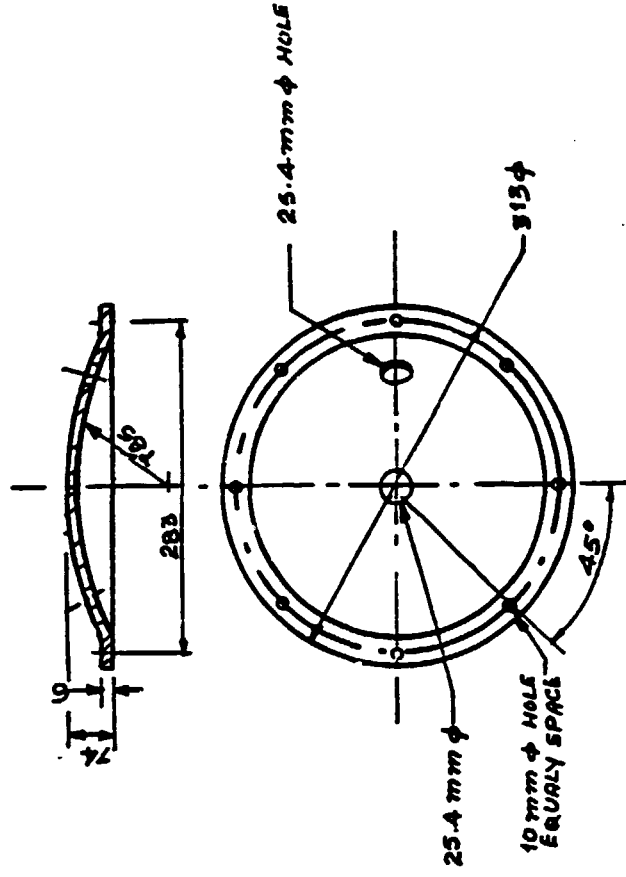

REACTOR COVER
MRTL:- M.S.

NOTE:-
- ALL DIMENSIONS ARE IN MM
- TOLERANCE 10.05

DRAWING NO. V-IV

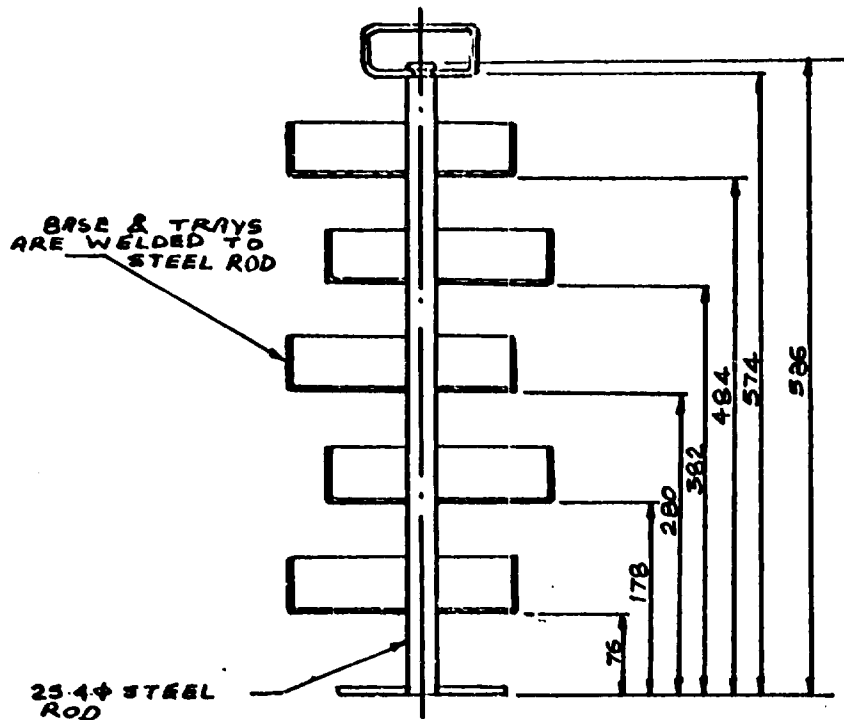

SUB-ASSEMBLY OF TRAYS & STAND

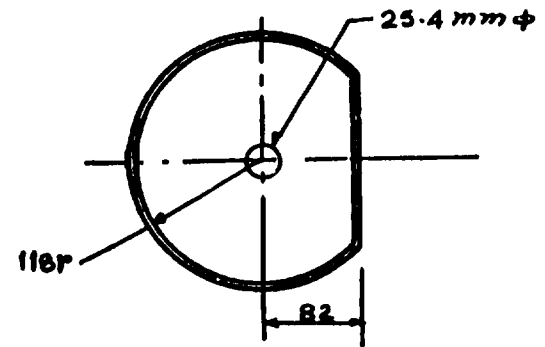
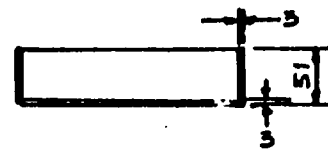

TRAY

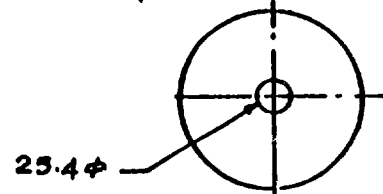
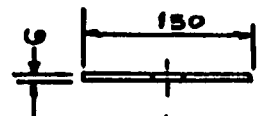

BASE

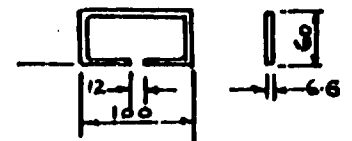

HANDLE

NOTE:
- ALL DIMENSION ARE IN M.M.
- TOLERANCE ± 0.05

DRAWING V-V

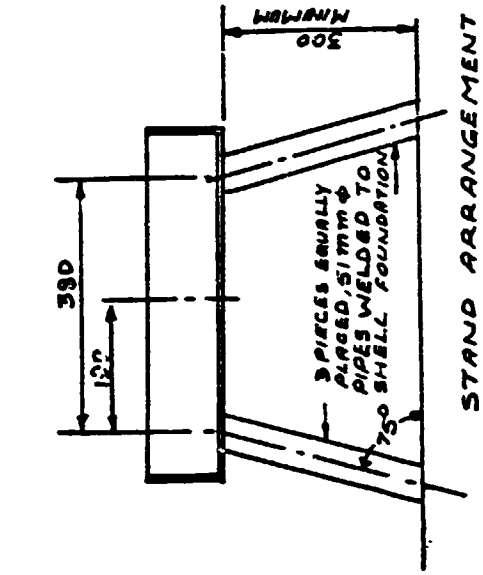

NOTE:-
- ALL DIMENSIONS IN M/M.
MATEL:- MILD STEEL

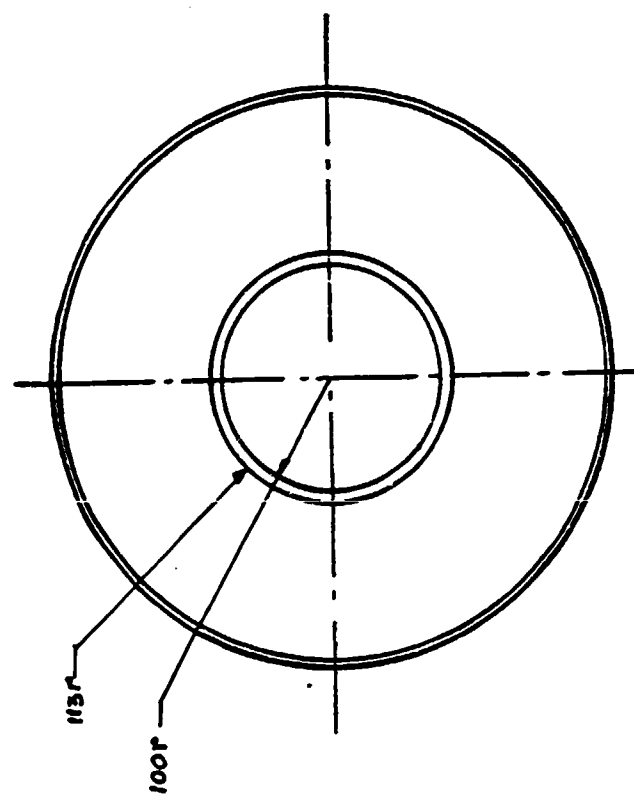
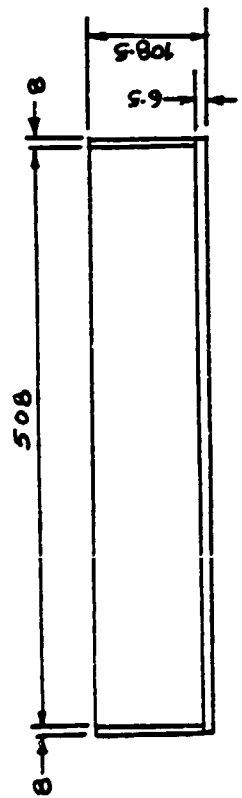

DRAWING NO - V - VI

ANNEXURE VI

SKETCH AND FABRICATION DRAWINGS

OF

RICE HUSK GAS STOVE

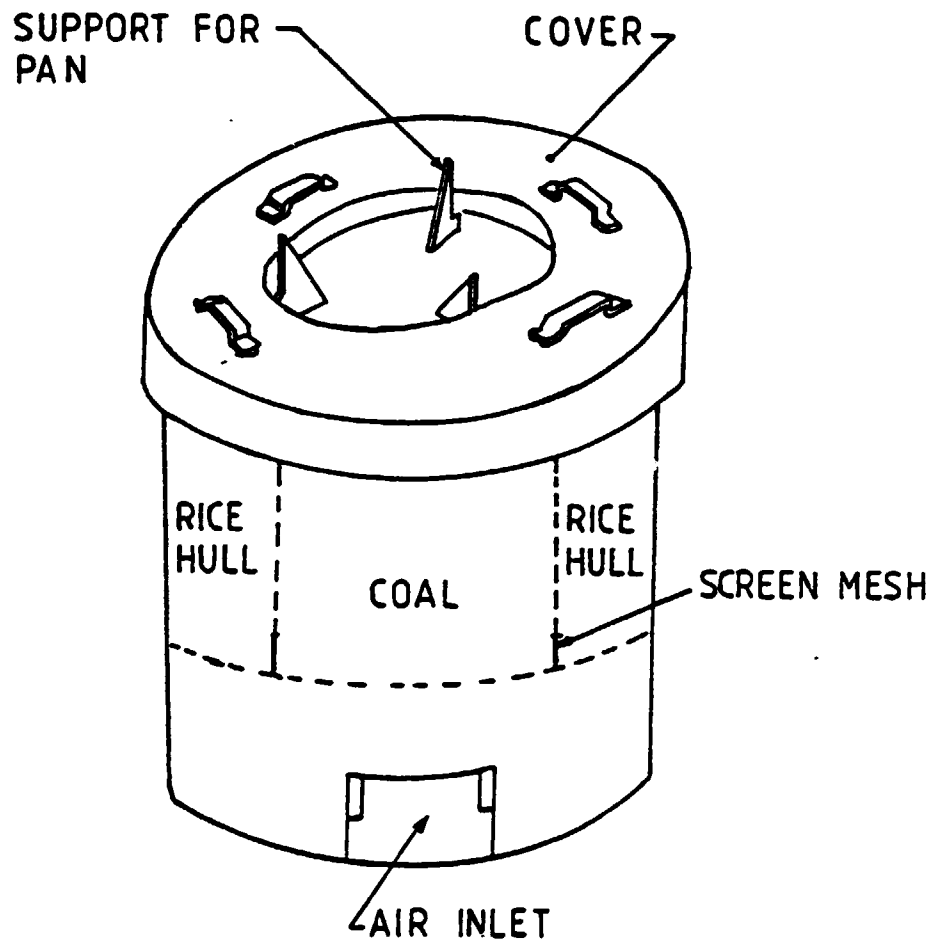

RICE HULL STOVE

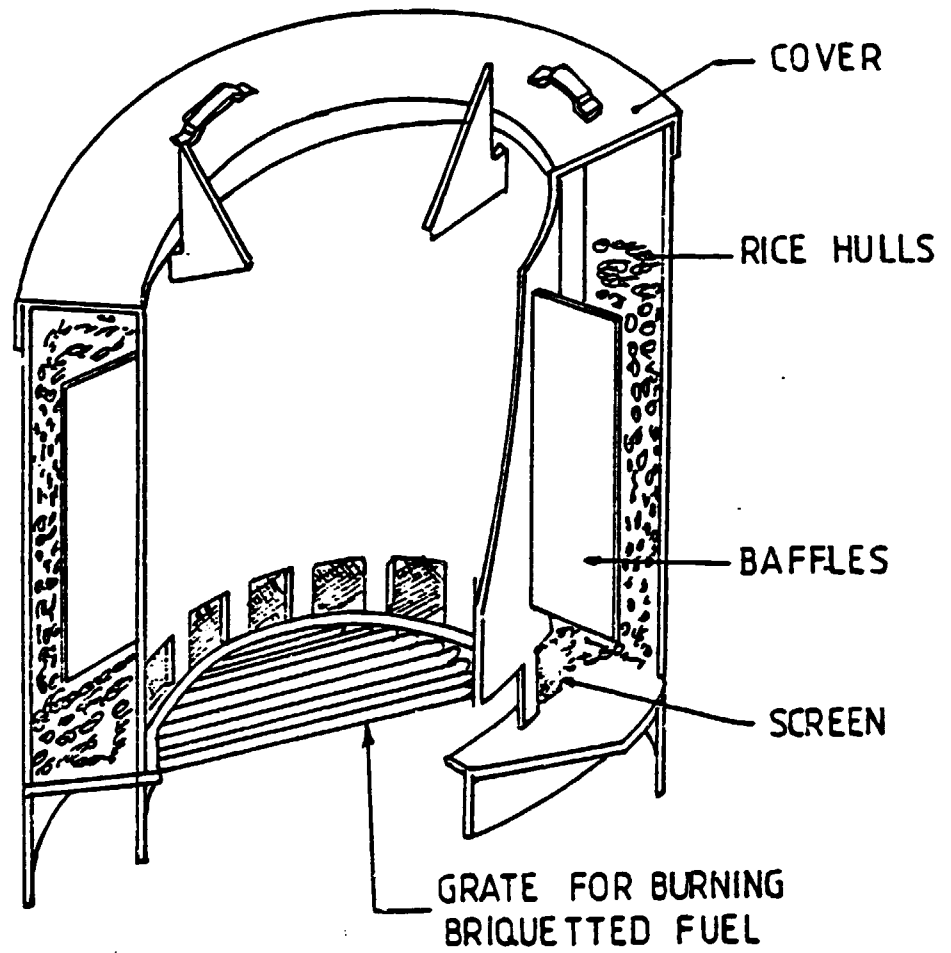

SECTIONAL VIEW OF RICE HULL STOVE

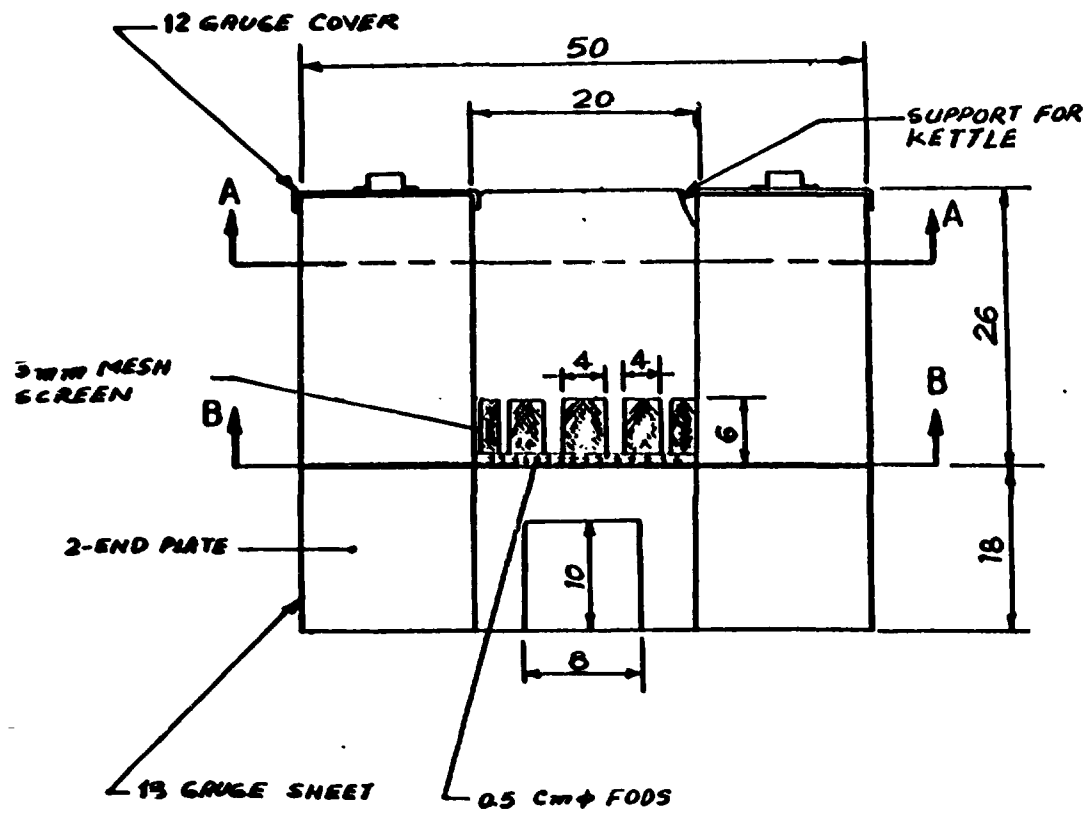

RICE HUSKS STOVE

NOTE:- ALL DIMENSIONS IN CMS.
MATL:- MILD STEEL

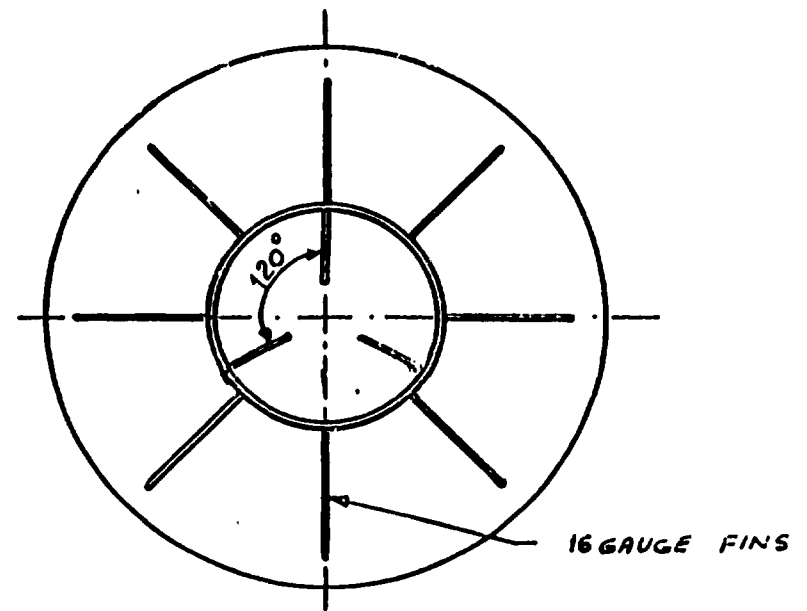

SECTION AA

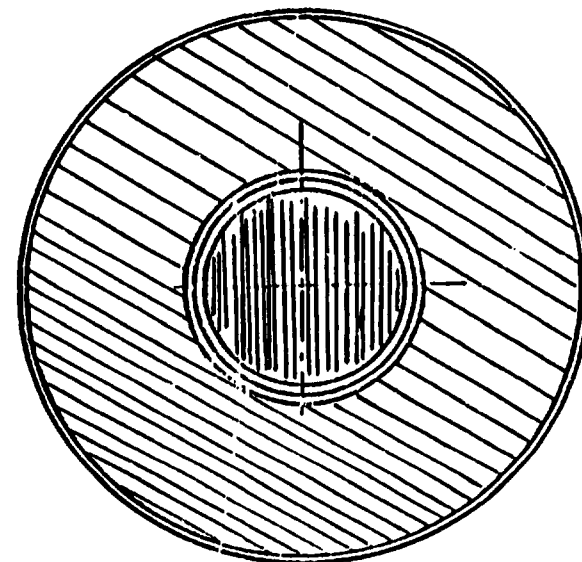

SECTION BB



4.03.21
AD. 85.03
III I 5 5