



TOGETHER
for a sustainable future

OCCASION

This publication has been made available to the public on the occasion of the 50th anniversary of the United Nations Industrial Development Organisation.



TOGETHER
for a sustainable future

DISCLAIMER

This document has been produced without formal United Nations editing. The designations employed and the presentation of the material in this document do not imply the expression of any opinion whatsoever on the part of the Secretariat of the United Nations Industrial Development Organization (UNIDO) concerning the legal status of any country, territory, city or area or of its authorities, or concerning the delimitation of its frontiers or boundaries, or its economic system or degree of development. Designations such as “developed”, “industrialized” and “developing” are intended for statistical convenience and do not necessarily express a judgment about the stage reached by a particular country or area in the development process. Mention of firm names or commercial products does not constitute an endorsement by UNIDO.

FAIR USE POLICY

Any part of this publication may be quoted and referenced for educational and research purposes without additional permission from UNIDO. However, those who make use of quoting and referencing this publication are requested to follow the Fair Use Policy of giving due credit to UNIDO.

CONTACT

Please contact publications@unido.org for further information concerning UNIDO publications.

For more information about UNIDO, please visit us at www.unido.org

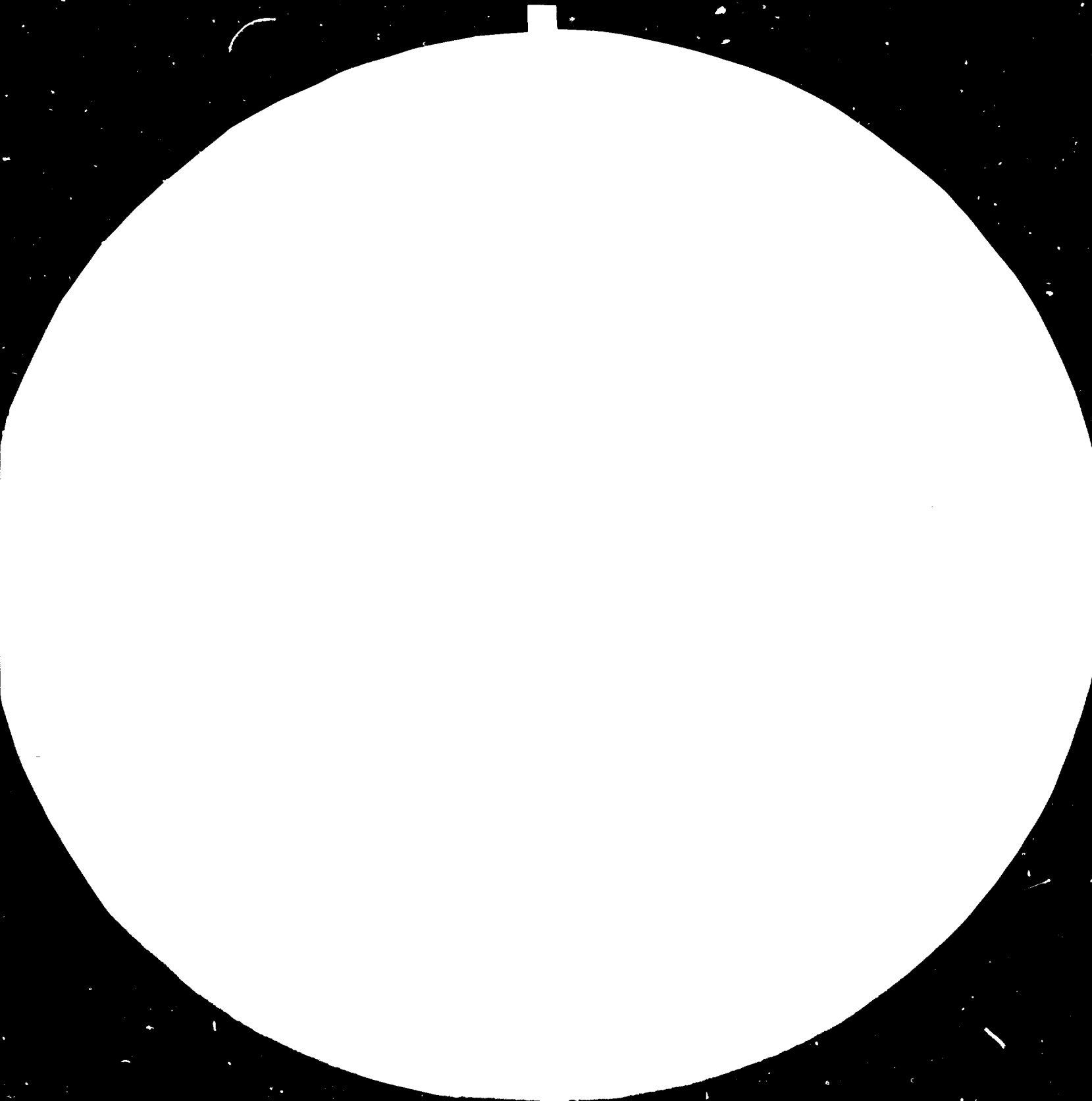



3.2

3.6

4



MICROCOPY RESOLUTION TEST CHART

NATIONAL BUREAU OF STANDARDS-1963-A

12971

AUSTRALIA - U.N.I.D.O. WORKSHOP

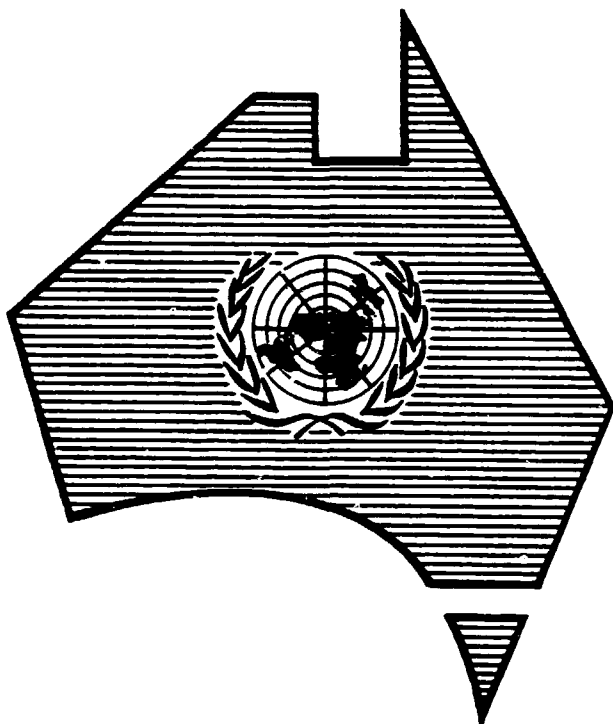

**WASTE HEAT RECOVERY
IN
INDUSTRIAL PROCESSES**

1150

**28 FEBRUARY - 11 MARCH 1983
MELBOURNE
AUSTRALIA**

AUSTRALIA/UNIDO WORKSHOP:

WASTE HEAT RECOVERY IN INDUSTRIAL PROCESSES
28th FEBRUARY — 11th MARCH 1983 MELBOURNE

C O N T E N T S

	<u>PAGE</u>
1. Introduction	1
2. Opening Statements	2
. Australian Government	
. UNIDO	
3. Conclusions and Recommendations	9
4. Selected Background Papers	11
5. Attachments	196
. Overseas Participants	
. Australian Industry Participants	
. Workshop Officials	
. Program	

AUSTRALIA/UNIDO WORKSHOP:

WASTE HEAT RECOVERY IN INDUSTRIAL PROCESSES
28th FEBRUARY - 11th MARCH 1983 MELBOURNE

1. INTRODUCTION

Over the period 28 February - 11 March 1983 an Australia/United Nations Industrial Development Organisation (UNIDO) workshop on Waste Heat Recovery in Industrial Processes was held in Melbourne, Australia.

The workshop which was the fifth in a series was funded through a contribution made under Australia's aid vote to the United Nations Industrial Development Fund. The objectives of the workshop were to discuss a wide range of waste heat recovery techniques which were considered to be relevant to the industrial environments of developing countries in the Asia/Pacific region.

Presha Engineering (Aust) Pty Ltd were largely responsible for the development of the program which included technical discussion sessions led by industry experts in various fields and a series of site visits.

The workshop was attended by 17 delegates from the following countries - Bangladesh, Burma, India, Indonesia, Pakistan, Papua New Guinea, Singapore, Sri Lanka and Thailand.

This report contains copies of the various papers presented, the conclusions and recommendations which were agreed and contact points for the various people involved.

AUSTRALIA/UNIDO WORKSHOP:

WASTE HEAT RECOVERY IN INDUSTRIAL PROCESSES
28th FEBRUARY — 11th MARCH 1983 MELBOURNE

OPENING ADDRESS BY MR D.J. FRASER, FIRST ASSISTANT
SECRETARY, INDUSTRY DIVISION NO. 2 DEPARTMENT OF
INDUSTRY AND COMMERCE, CANBERRA

On behalf of the Australian Government, I would like to welcome you to Australia - and in particular to this Workshop.

You have, of course, arrived in Australia just a few days before a Federal Election.

I hope you will find it interesting to observe our democratic processes in action.

- If you don't find it interesting, I'm afraid you will find very little to read in your newspapers, watch on television or listen to on the radio.

My appearance here this morning represents one tiny ripple from the stone of the Election.

- A Workshop such as this would normally be opened by a Minister of the Crown.
- But you will understand that Ministers are somewhat preoccupied at present.

I'd like especially to welcome our UNIDO Colleague, Mr. Komissarov.

This Workshop is a direct result of his visit to Australia a year ago.

Mr. Komissarov will be talking to you shortly about the work of UNIDO in the field of industrial development.

For my part, I would like to explain briefly the involvement of the Australian Government in this field.

In recent years, Australia and UNIDO have worked increasingly closely together in furthering the industrialisation of developing countries.

- And particularly of those in the Asia/Pacific Region.

This closer relationship results from a number of factors:-

- First, I believe there is a growing awareness within UNIDO of Australia, of her strategic location in the Asia/Pacific Region and of the relevance of her industrial experience to the needs of other countries in that region. An awareness which has resulted at least in part from a series of visits to Australia by very Senior Officials of the UNIDO Secretariat.

- Secondly, Australian Industry is becoming much more actively involved with countries in the region.
 - . Much of this involvement, of course, has been for commercial reasons.
 - . But our industry has also shown itself willing and able to take part in development assistance activities.
- And thirdly, the Australian Government has not only maintained its high interest in UNIDO's policy activities.
 - . But now also actively supports UNIDO's technical assistance programs by allocating funds to the United Nations Industrial Development Fund.

One way in which the closer relationship has manifested itself has been the planning of a series of UNIDO Seminars in Australia

- of which this today is the latest example.

The major objective of the series is to provide an opportunity for representatives of developing countries to examine and discuss, at first hand, recent developments in selected industry sectors.

We hope you will find that what you see of Australian industry is interesting and relevant to your own industrial environment.

And we hope you will take the opportunity the workshop provides to share your own country's experience with your fellow Delegates and with us.

Subjects for this series of Workshops are worked out by UNIDO, by the Australian Department of Industry and Commerce and by Australian Industry, working in close consultation.

Perhaps at this stage, I should digress briefly to explain the role of my own Department, Industry and Commerce, in this process.

The primary policy role of the Department is to advise its Minister, and through him the Government, on policies relating to Australian manufacturing and tertiary industries.

In carrying out that role, we are naturally in close and frequent contact with Australian industry.

We are naturally also involved in the activities of a range of international organizations concerned with industry policy

- One of which is UNIDO

We are able, therefore, to compare UNIDO's requirements and Australian industry's strengths, and to join with these two other parties in planning activities like today's Workshop.

I might say that, not only during but also after this Workshop, my Department will be delighted to help you in any way we can

- and I suggest you use us as your primary point of contact with the Australian Government.

In choosing subjects for these Workshops, then, we try to match Australian industry's capabilities to UNIDO's needs.

We try also to pick topics which are of immediate relevance to your countries, and where the lead-time for spin-off benefits will not be too long.

We have recently had a Workshop on Cement and Concrete Products, and another on selected building materials (both, I'm told, very successful) and another one is being planned for May, which will cover Timber Engineering.

I hope you agree that the subject of this present Workshop is well chosen.

Concern about energy consumption has risen dramatically in recent years.

The background to this concern is well documented. Oil prices at the moment appear to be moving down rather than up, but the surges upwards, of recent years, have taught us all that we need to improve the ways in which we use energy.

- And in particular that we need to minimise waste.

Industries the world over are developing energy management techniques. These techniques

- are often relatively simple,
- pay for themselves after only a short time,
- and give attractive Benefit-to-cost ratios.

Here in Australia, we have developed our own techniques and adapted and applied techniques from overseas, and this Workshop is intended to show you what we are doing in the field of recovering waste heat generated in industrial situations.

Presha Engineering (Aust.) Pty. Ltd. specialises in this field of Waste Heat Recovery

- and it is largely through the efforts of that firm's Managing Director, Mr. John Wrigglesworth, that the Program for this Workshop has been developed.

At this stage, I would like to record a special commendation to Mr. Wrigglesworth and his staff for the work they have put into the Program.

I would like also to thank in absentia, the other people from Australian industry who have given freely of their time and effort to ensure that the Workshop is a success.

Your Program includes:

- Papers presented by Australian and International experts.
- Visits to see waste heat recovery techniques in action.
- And a Panel Session where each of you can describe developments in your own country.

The organisers have so arranged the Program as to give you plenty of opportunities not only to see and hear, but also to question and discuss.

I am sure that you will all become very actively involved and thus ensure that this Workshop is a success.

I am sure, too, that you will not see the Workshop as an isolated event. We see the follow-up phase as being particularly important, and I suggest that towards the end of the Workshop you will need to give considerable thought to the conclusions and recommendations which should flow from your work here.

In closing, I would repeat - My welcome to you to Australia and to this Workshop.

- My thanks, on behalf of the Australian Government and of my Department, to Mr. Komissarov, Mr. Wigglesworth and the many others who have worked hard to make the occasion a success.
- And my best wishes for an enjoyable stay in this country and for a useful and successful Workshop.

I now have great pleasure in declaring this Workshop open.

Thank you.

* * * * *

AUSTRALIA/UNIDO WORKSHOP:

WASTE HEAT RECOVERY IN INDUSTRIAL PROCESSES
28th FEBRUARY — 11th MARCH 1983 MELBOURNE

MESSAGE DELIVERED BY MR G. KOMISSAROV ON BEHALF
OF ABD-EL RAHMAN KHANE, EXECUTIVE DIRECTOR OF
UNIDO

Ladies and Gentlemen,

The subject chosen for this important workshop is of great importance and I am sure that the information exchanged in this forum will greatly benefit developing countries. I am convinced it will also make a significant contribution to the operational energy-related programme of UNIDO.

UNIDO has always recognized the importance of and welcomed the co-operation among countries, developed and developing. In this connection I would like to express my sincere appreciation to the Government of Australia which made this meeting possible through a voluntary contribution as well as through utilizing the experience and facilities of Fresha Engineering.

It has become increasingly clear that social, economic and, particularly, industrial development are inextricably connected with energy development and utilization. Although other inputs, such as technology, human resources, finance and raw materials, are also essential for the operation, establishment and expansion of industry, energy is at present one of the most critical factors, and it has become a decisive factor determining international trade and economic relations.

Industry is central to the development process, but it is also central to the development of energy itself and its utilization particularly in relation to energy-efficient design of manufactures which consume energy. Consequently, UNIDO has embarked on a new phase of activity, together with other bodies of the UN system, in relation to the development and utilization of energy

resources in developing countries, specifically new and renewable ones. On the basis of UNIDO's experience and studies, it is by now clear that the attention of technologists, planners and managers, in governments and in industry, should be focused on three main areas for action which can be identified as: "Energy for Industry", "Industry for Energy", and "Industrial Energy Management".

Good energy management with special attention to efficient energy utilization and energy savings has always been a primary concern in industrial operations. The problem has, however, become acute in recent years, with the scope and urgency of such programmes being increased to the point when energy management is receiving the closest attention from both industry and governments: at national, sectoral and plant levels.

In industrial and agro-industrial processes in developing countries, a vast quantity of waste heat energy is exhausted into the atmosphere and totally lost. This occurs in cases of the incineration of organic and industrial waste and in the emission of furnace and plant waste gases. In many cases, an investment in a waste heat recovery system is economic, yielding available heat for minimal current cost. The benefit of installing systems can include recovery of a high percentage of heat now wasted in industrial processes, with commensurate reduction in fuel usage. The investment can often pay for itself in one or two years.

Particularly in view of the high cost of energy, there is a great need for developing countries to be able to assess the economics of waste heat recovery systems and to install and operate such equipment. Many instances of waste heat have unique characteristics, which need to be recognized and evaluated. The workshop will aim to assess and identify the required skills and techniques.

In the course of the work of this workshop, I am sure that most valuable contributions will be made, on the above issues which will also be of the greatest interest to developing countries not represented in this meeting. UNIDO will do its best to convey to them the essence of your experience and of the views expressed here.

I was pleased to visit Australia two years ago and to see that there was great potential for co-operation with UNIDO. Subsequently a UNIDO mission visited Australia to investigate in detail the possibilities for co-operation in the energy sector. It is gratifying that these visits have borne fruit in form of this workshop, as well as other activities. I am confident that this workshop will be a stepping-stone towards further co-operation for the benefit of developing countries.

With my best wishes for a successful workshop.

Abd-El Rahman Khane

Executive Director of UNIDO

AUSTRALIA/UNIDO WORKSHOP:

WASTE HEAT RECOVERY IN INDUSTRIAL PROCESSES
28th FEBRUARY — 11th MARCH 1983 MELBOURNE

CONCLUSIONS

1. The Workshop was successful in providing delegates with a wide range of waste heat recovery techniques relevant to their industrial environments, through a series of discussions and practical demonstration sessions. The program investigated a broad range of technologies utilised in waste heat recovery processes in industrial situations (including production of biogas from waste, power generation, heat exchange design systems and fluidised bed combustion techniques).
2. In many instances, simple inexpensive programs could be introduced which would result in more judicious and appropriate use of available energy resources. In this regard, particular note was taken of the role energy audits could play and of the benefits that would accrue through the introduction of "housekeeping" programs.

* * * * *

AUSTRALIA/UNIDO WORKSHOP:

WASTE HEAT RECOVERY IN INDUSTRIAL PROCESSES
28th FEBRUARY — 11th MARCH 1983 MELBOURNE

RECOMMENDATIONS

1. Recognising the substantial cost benefits associated with the introduction of efficient energy management programs, it is recommended that priority be given to developing national strategies aimed at promoting and introducing relevant programs, particularly in the field of waste heat recovery.
2. Developing countries should give high priority to the setting up of energy management establishments which have the major objective of investigating and co-ordinating national efforts to develop sound and practical energy management programs. These organisations should be structured to suit the individual requirements of each country.
3. Accepting the need for this initial Workshop to cover a diverse spectrum of technologies and industries, it is recommended that future workshops deal with the application of waste heat recovery techniques in specific industry sectors, for example in fluidised bed combustion.
4. It is recommended that developing countries identify areas and projects where the application of waste heat recovery techniques is considered to be of particular priority.
5. It is recommended that the prospects of carrying out feasibility studies relating to the introduction of relevant waste heat recovery techniques in identified priority areas be examined at the national level and that UNIDO assistance be sought, where necessary, to assist in carrying out such studies.
6. It is recommended that an educational program for senior management within both the government and non-government sectors be developed to identify and provide support for the introduction of appropriate waste heat recovery techniques and which, in particular, draw attention to the short pay-back periods often involved.
7. It is recommended that Australian industry experts make themselves available to participate in future workshops and technical assistance projects in this field.
8. It is recommended that participants in the Workshop ensure that the information they have obtained during the course of the Workshop receives maximum dissemination within each of their countries.

* * * * *

AUSTRALIA/UNIDO WORKSHOP:

WASTE HEAT RECOVERY IN INDUSTRIAL PROCESSES
28th FEBRUARY — 11th MARCH 1983 MELBOURNE

SELECTED BACKGROUND PAPERS

	<u>PAGE</u>
. Assessing the Potential for Waste Heat Recovery Projects	12
. Optimising Power Generation and Heat Generation through co-generation	27
. Using Energy Management Centres to Implement National Energy Conservation Programs	34
. Heat Recovery in Dairy Factories	59
. Combined LNG and Atmospheric Gas Production	73
. Energy Conservation in Industry	92
. Application of Thermodynamic Principles to Optimise Energy Conservation Designs	97
. Heat Exchanger Network Design	135
. Conversion Burners	159
. Suspension Burning of Wood and Agricultural Wastes	162
. Municipal Refuse Burning	165
. Fluidised Bed Combustion	167
. Biogas Utilisation	189

AUSTRALIA/UNIDO WORKSHOP:

WASTE HEAT RECOVERY IN INDUSTRIAL PROCESSES
28th FEBRUARY — 11th MARCH 1983 MELBOURNE

ASSESSING THE POTENTIAL FOR WASTE HEAT
RECOVERY PROJECTS

Mr L.M. Adams
Engineer in Charge
Consultancy Services
Energy Management Centre
Gas & Fuel Corporation of Victoria

1.0 INTRODUCTION

As a preface to this paper, I should like to briefly outline the development of the Centre's involvement in Energy Management over recent years.

The Energy Management Centre was set up in 1977 with the following broad objectives:

- . To educate industry and commerce in the efficient use of energy;
- . To provide information which will assist in long term planning by senior executives;
- . To encourage positive attitudes towards energy management;
- . To motivate senior executives to implement effective energy management programs.

The Centre operates through three divisions:

- . Education Division - this group conducts seminars and training courses for industry and commerce.
- . Development Division - this group undertakes implementation of development and demonstration projects designed to assess energy saving concepts and equipment under actual plant conditions.
- . Consultancy Division - this group undertakes in-plant energy studies on a fee for service basis, to outline energy saving opportunities and to provide a complete energy saving program.

The information and procedures outlined in this paper result from over 100 studies conducted by the Consultancy service and the demonstration projects and feasibility studies conducted by the Development division.

2.0 ENERGY MANAGEMENT

It is probably worthwhile to first define what we at the Centre mean by the term "Energy Management" and where waste heat recovery fits in to an energy management program.

In the Australian industrial environment energy management should be seen as essentially a cost cutting exercise. Therefore proposals to increase energy efficiency must be shown to be economically viable. In fact the whole energy management program must be seen to be beneficial to the Company as a cost cutting exercise. While this criteria may at first appear to be too narrow, it is in fact compatible with overall national objectives of reducing dependence on imported fuels. It is our belief that in any industrial energy management program, waste heat recovery ought to be one of the last areas to be investigated. This is because it is invariably an expensive exercise and because a great deal can be done initially to reduce energy costs without spending a lot of money.

As the energy management program progresses the Energy Manager will need to look at what is actually happening in the plant according to priorities defined by the on-going energy audit which he has set up. Specific actions to be undertaken in the plant usually fit into one or more of the following categories.

- . Housekeeping. This area covers cost savings achieved by elimination of wastage in obvious areas. The savings made are not usually spectacular but the minimal costs involved generally result in simple payback periods of one to four months. This area should always be tackled first.

- . Process Improvement. This phase follows the previous one and aims at ensuring that existing processes are operating as efficiently as possible. Detailed analyses of processes are usually necessary and some

capital expenditure may be required. Cost savings are generally greater than the previous phase, however a reasonable level of technical expertise is required. Investment payback periods may vary from 6 months to 1½ years.

- Process Development. This phase of the program aims at further development of processes by addition of retrofitted equipment or the installation of new equipment employing the latest technology. This phase is almost always expensive; requiring large capital investments. Potential energy cost savings, however, can be truly spectacular, with energy savings of 30-40% being quite common. Simple payback periods may range from one to three years. This phase should be undertaken last of all.

Waste heat recovery projects fall very definitely into the last category and require very careful analysis because of the large commitment of capital funds generally required. Considerable technical expertise is also necessary and plant management may enlist the aid of outside consultants if specialist knowledge is required.

3.0 EVALUATION OF WASTE HEAT PROJECTS

In the course of a plant energy study our consultants attempt to gain a thorough understanding of plant processes through observation, discussion with plant personnel (which often results in conflicting ideas) and finally by direct measurements. Identification of realistic waste heat recovery opportunities is not possible without this fundamental understanding of the processes involved.

A number of important questions need to be considered when identifying waste heat recovery proposals, viz:

- a) What quantity of waste heat is available, where and at what temperature? (All thermal processes produce some waste heat).
- b) What can the waste heat be used for, how much is required and at what temperature?
- c) Is the supply of waste heat available greater than or less than that required by the user process?
- d) Will the waste heat be used more usefully by the process which generates it (closed loop system) or will it be used by some other unrelated process (open loop)?
- e) Is the waste heat being generated unnecessarily?
- f) Is the recovery proposal technically practical and economically viable.

The answers to questions a) to d) requires a reasonably straight forward and logical engineering analysis, involving the production of mass and energy balances for the processes involved, together with an assessment of any constraints caused by overall plant operation. Ultimately a decision will be made between competing technically sound proposals on the basis of financial viability.

(Question f))

In relation to question d) a closed loop waste heat recovery system (i.e. one in which the process which generates the waste also uses it) will generally cause fewer control problems. Open loop systems can cause problems when the process which produces the waste heat generates more waste than is required by the user process. At best this may be a nuisance and in the worst case may even be detrimental to the operation of the waste generating process.

In our experience, however, it is the answer to question e) (Is the waste being generated unnecessarily?) which makes the difference between a successful proposal and a financial disaster. So often this question is not even asked. An example of such a situation is worth considering in some detail.

This example arose from a study conducted in a medium sized manufacturing establishment making hand tools. This Company did not have an effective energy management program but had become concerned about the rising cost of energy. The Company decided to recover waste heat from the flue of a gas fired phosphating tank. The recovered hot combustion products were to be ducted directly to a paint drying oven (also gas fired) to reduce its gas consumption.

The arrangement of the production process is shown in Figure 1. The plant operated 2 000 hrs per year and the average cost of gas was \$2.50 per GJ. Flue gas analysis of the phosphate tank produced the following results:

O ₂	-	9.5%	Flue gas temp = 350°C
CO ₂	-	6.6%	
CO	-	Nil	

Total burner input = 2.6 GJ/hr

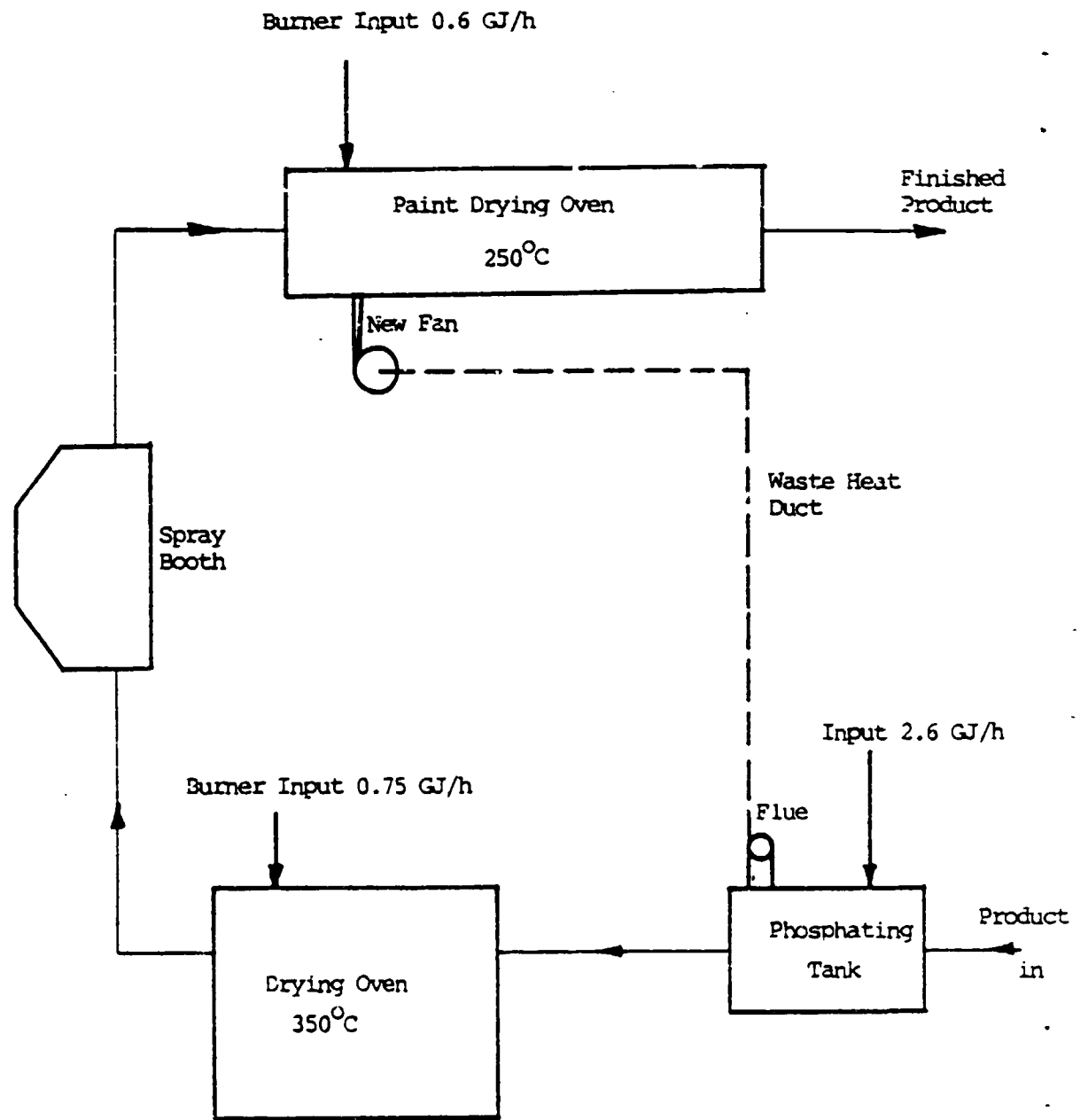

FIGURE 1. HAND TOOL PAINT LINE

From these results a flue gas loss of 29% of burner input was determined implying exhaust waste heat amounting to:

$$\text{Flue waste heat} = 2.6 \times \frac{29}{100} = 0.75 \text{ GJ/hr.}$$

It was determined (conservatively) that 55% of this heat would be available at the paint baking oven at a usable temperature.

$$\therefore \text{Available Waste heat} = 0.41 \text{ GJ/h}$$

This represented over 60% of the heat required by the paint drying oven at a temperature (350°C) in excess of that required by the paint oven.

$$\begin{aligned} \text{Thus annual fuel saving} &= 0.41 \times 2\,000 \text{ GJ/year} \\ &= 820 \text{ GJ/yr.} \end{aligned}$$

$$\begin{aligned} \text{Cost savings} &= 820 \times 2.5 \\ &= \$2\,050 \text{ per year} \end{aligned}$$

It was proposed to use a simple direct recovery system using a "hot" fan and insulated ducting. The estimated capital investment was \$4 000.

$$\begin{aligned} \text{The simple payback period was thus} &= \frac{4\,000}{2\,050} \\ &= 1.9 \text{ years} \end{aligned}$$

A more detailed discounted cash flow analysis yielded an internal rate of return of 23% after tax and depreciation and based on an investment life of 5 years and an annual increase in gas price of 5% per annum.

From this superficial analysis it appeared that the decision to recover waste heat in this manner could be financially viable. However, at this stage the operation of the phosphate tank burner was reviewed. The excess air level of the burner was considered far too high (74%) and it was decided that the burner could be trimmed back to yield a flue gas oxygen level of 5%. This would result in a flue gas loss of 24% of input.

$$\text{New input} = 2.43 \text{ GJ/hr}$$

$$\therefore \text{Flue gas loss} = 2.43 \times \frac{24}{100} = 0.58 \text{ GJ/hr}$$

Assuming again that 55% of this heat could be recovered.

$$\text{Available waste heat} = 0.32 \text{ GJ/hr}$$

$$\text{Annual saving} = 0.32 \times 2000 = 640 \text{ GJ/year}$$

$$\text{Cost saving} = 640 \times 2.5 = \$1600 \text{ per year}$$

$$\text{Simple payback period} = \frac{4000}{1600} = 2.5 \text{ years}$$

$$\text{Internal rate of return} = 12\%$$

This return in investment (approximately half of its original) was not considered acceptable by the Company and the proposal did not go ahead.

However a fuel saving of 0.17 GJ/hr or 340 GJ/year valued at \$850 per annum was made by improving the burner operation for almost no cost.

This example illustrates the point that waste heat recovery should not be applied to an inefficient process.

Implementation of an effective energy management program would have identified and corrected this process inefficiency before the possibility of waste heat recovery was even considered. There are sufficient opportunities for soundly based recovery proposals without wasting money on recovering waste heat from inefficient processes.

The following section illustrates some waste heat or waste energy recovery proposals which have been identified in the course of our energy studies.

4.0 CASE STUDIES

The procedure adopted by our consulting engineers, when assessing waste heat recovery opportunities as part of a wider study, is to gather sufficient information to make an initial appraisal of financial viability. If this initial assessment is very favourable (simple payback less than 1½ years) then a recommendation will be made that a detailed engineering study be undertaken and the project proceed. If the simple payback period is between 2 and 3 years, then additional data may be gathered to more accurately assess the proposal. If the payback period is much greater than 3 years we would generally recommend that the project not proceed.

- a) Acid Plant. This plant formed part of a large lead smelting works. The process involved preheating acid gas feedstock to 620°C. The arrangement is shown in Fig. 2. Make-up heating is provided by a once-through gas fired heater. The air heater consists of a combustion chamber fired by a single gas burner with average input of 11 200 MJ/hr providing hot combustion products which are mixed with outside air from a dilution fan. The resulting hot air is limited to a maximum of 620°C at inlet to the preheater. The preheater exhaust temperature was measured and found to average 400°C.

It was proposed that the fuel input could be reduced by recirculating a fraction of the exhaust flow by means of an additional fan. The proposed arrangement is shown in Fig. 3. From mass and energy balances it was determined that a recirculation rate of 80% could be achieved. This resulted in a fuel saving of approximately 50%. The fuel saved amounted to 48 600 GJ per year valued at \$73 000 per annum. The capital cost of the modifications was estimated at \$35 000 yielding a simple payback period of 6 months. The internal rate of return based on an investment life of 5 years was 115% after tax and depreciation. This proposal thus represented a real opportunity

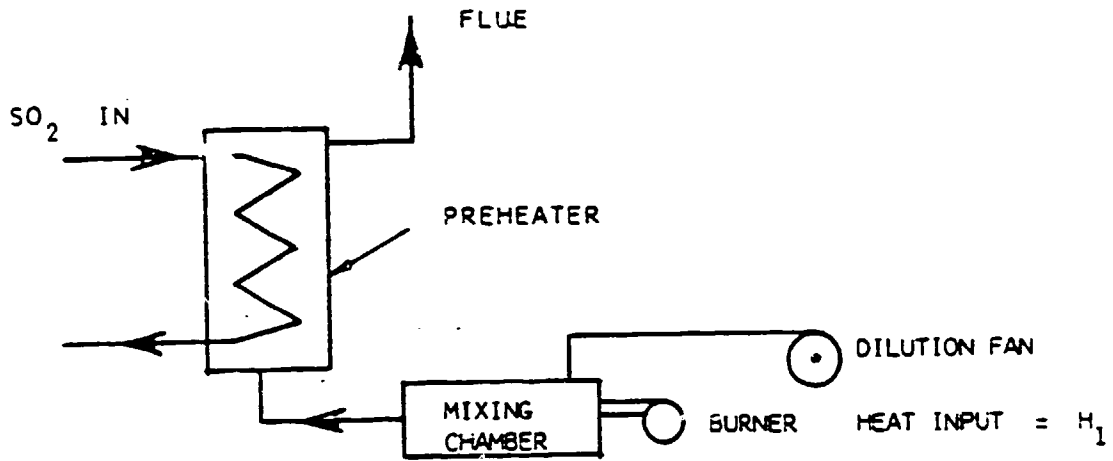

Fig.2 EXISTING ARRANGEMENT

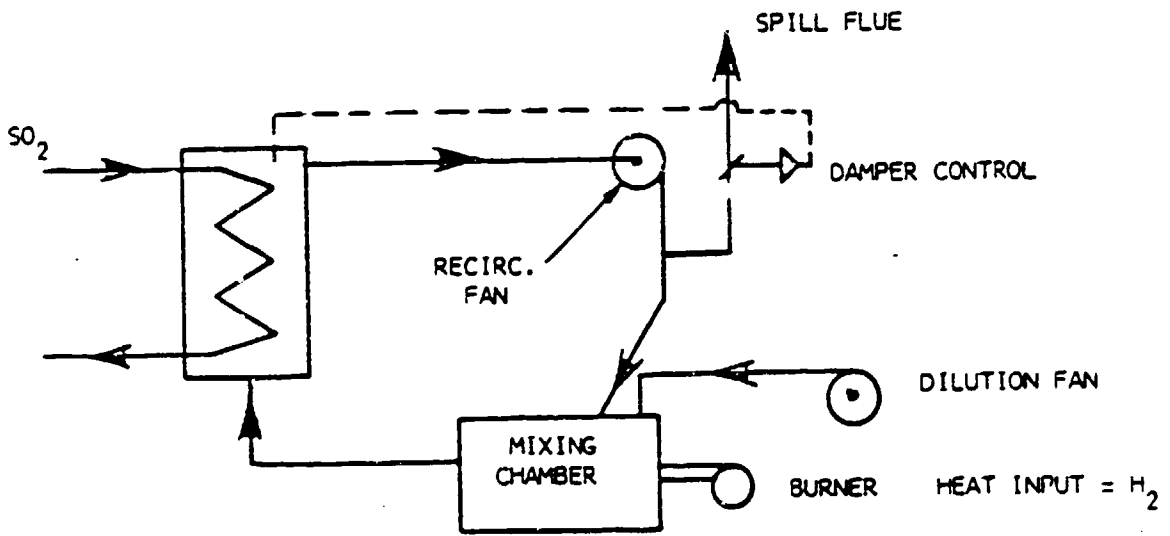

Fig.3 PROPOSED ARRANGEMENT

ACID PLANT PREHEATER
EXISTING AND PROPOSED ARRANGEMENTS

for cost saving. This type of recovery system although it does not require a recuperator or regenerator is nevertheless an example of one of the simplest methods of waste heat recovery, and one which is often overlooked.

- b) Process Steam - Power Generation. Steam is required at the paper machines in a large paper mill. at a rate of 90 000 kg/h at 350 kPa (50 psig) dry saturated. The process is shown schematically in Fig. 4. Steam is generated in the boilerhouse in two radiant bi-drum boilers at 1 400 kPa (200 psig) with 62°C of superheat. It is supplied to the paper machine with 20°C of superheat, is desuperheated and regulated down to 350 kPa.

It was proposed to install a back pressure turbo-generator set with inlet steam conditions of 1 400 kPa and 260°C exhausting at 350 kPa and 168°C. The set was to be installed in parallel with the existing system as shown in Fig. 5. The turbine was to be governed on exhaust steam conditions dictated by the paper machine. From this information and in consultation with the turbo-generator supplier it was determined that a suitable set could be purchased giving a power output of 4 000 kW. At the clients incremental power cost the annual cost saving in electrical energy amounted to \$1 050 000 per year. The total investment for piping valves controls, the turbo generator and labour was estimated at \$1 400,000. The internal rate of return based on an investment life of 8 years is 47% after tax and depreciation (simple payback period 1.3 years). The project was considered to be an attractive proposition and we recommended that a detailed engineering study be undertaken. We also however suggested that as the existing boilers were near the end of their economic life the Company should consider the option of large scale co-generation by installing new higher pressure boilers and much greater installed turbo-generator capacity.

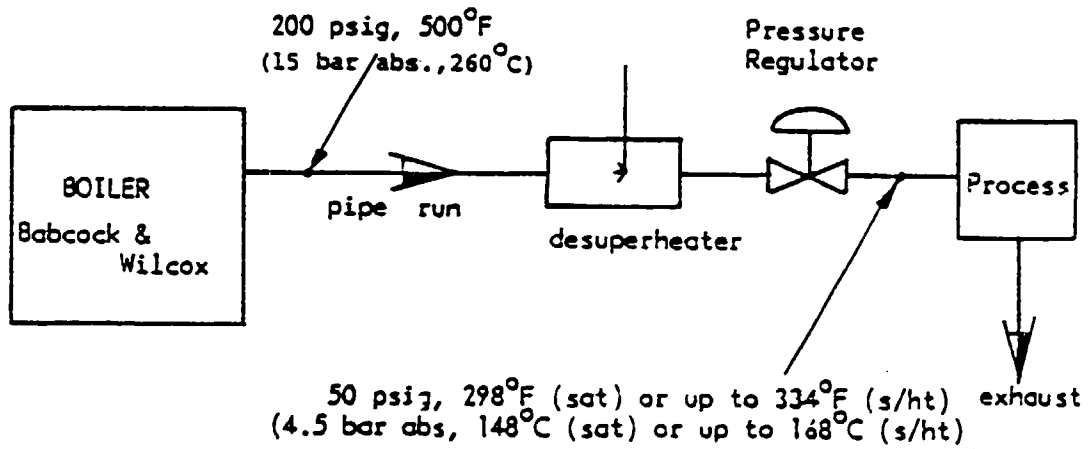

FIGURE 4: STEAM SYSTEM - EXISTING

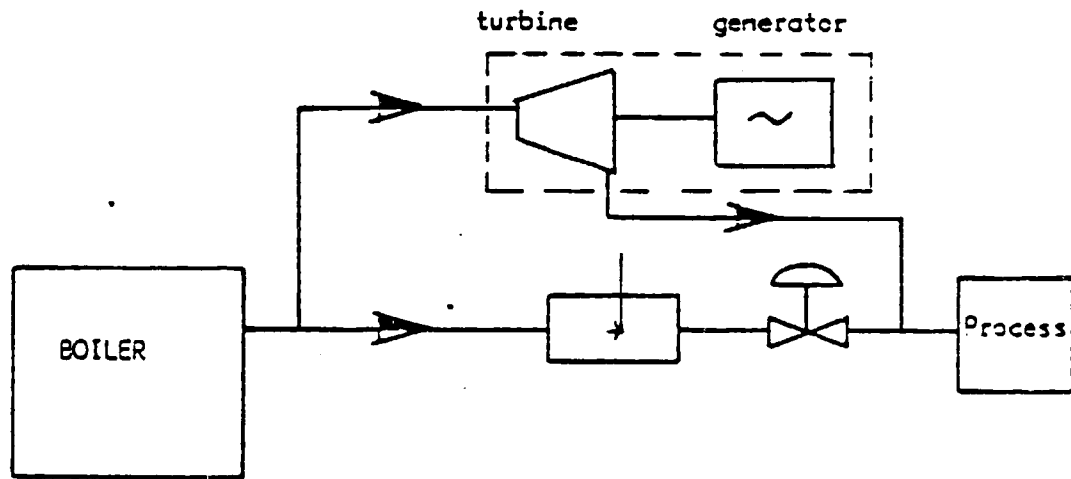

FIGURE 5: STEAM SYSTEM WITH POWER GENERATION (4 000 kW)

AUSTRALIA/UNIDO WORKSHOP:

WASTE HEAT RECOVERY IN INDUSTRIAL PROCESSES
28th FEBRUARY — 11th MARCH 1983 MELBOURNE

OPTIMISING POWER GENERATION AND HEAT
GENERATION THROUGH
CO-GENERATION

Mr A. Smithson
Manager
Industrial Gas Division
South Australian Gas Company

OPTIMISING POWER GENERATION AND HEAT GENERATION THROUGH CO-GENERATION

INTRODUCTION

Electricity generation in thermal power stations is not essentially an efficient operation - as I have already said - typically 30%. The remaining 70% of the primary energy in the fuel is lost to the environment as waste heat to the air or into the seas or rivers. There is therefore considerable scope for combining electricity generation with a process which can use this otherwise wasted heat.

Co-generation may be defined as the on-site generation of electricity by a commercial or industrial establishment with a significant process heat requirement whereby, through an electrical interconnection with the Generating Authority Grid system, power is allowed to flow in either direction depending on the needs or surplus capacity of the establishment.

The International Energy Agency in its survey of energy conservation in industry in I.E.A. countries, published in September 1979, states that:-

"Combined heat and power production (CHP or co-generation) holds prospects of large savings since it gives a total thermal efficiency at least 2.5 times that obtained when heat and electric power are generated separately."

Why then, is co-generation not universally employed? I will try and answer that question by looking at our experiences in South Australia so that, hopefully, you can benefit from what we have found and thus be in a stronger position to improve the utilization efficiency of the primary energy resources of your countries .

CO-GENERATION POTENTIAL

The concept of co-generation is essentially simple. A large number of industries use steam as the vehicle for transferring heat from the burning of fossil fuels to the point of use within the factory. Process steam can very easily be produced as a by-product of electricity generation and produce overall efficiencies in the order of 70% plus. The two most common types of plant used for co-generation are:-

- (a) High pressure steam being generated in a boiler which is fed into a back pressure steam turbine for electricity generation with the low pressure steam from the turbine being fed to the plant as process steam.

- (b) The fuel is fed directly into a gas turbine (this could also be a reciprocating engine) to generate electricity with the exhaust gases being fed into a waste heat boiler to generate the process steam for the factory.

The choice of which system is used will depend primarily on -

- (i) The relative proportions of electricity and steam required.
- (ii) The fuels available.
- (iii) The operator skills available.
- (iv) The overall economics of the systems in the particular circumstances.

With the enormous quantities of electricity being produced in thermal power stations, the potential for the use of waste heat from this operation is massive. In some countries, notably America and European countries, up to 20% of electricity supplied is cogenerated by Industry and in addition waste heat from power stations is used for distinct heating. Distinct heating, of course, would not be realistic in the temperate/tropic regions. It is only realistic in cold climates with high population densities.

WHY IS IT NOT UNIVERSAL

With the potential for co-generation being so high and its use at this stage comparatively small, we must ask "what is the catch - why is it not universally adopted."

The first reason must be that the western world has developed in an era of cheap fuels and abundant fuels so that the incentive to adopt co-generation as an integral part of any development was just not there. The energy costs were only a small part of an industry's costs and the available capital could be better spent elsewhere.

The question of available capital, together with the cost of that capital, is still a major stumbling block to its further development. The detailed economic assessment of the benefits to be achieved by investing large sums of money (often millions of dollars) must be the prime reason at present why industry does not invest in co-generation facilities. The risk factors must be low or the return on investment high before industry will commit large sums of money to equipment which, in itself does not contribute anything to production capacity.

The return on investment will depend on the savings in energy costs. Therefore, predictions of fuel price increases (or decreases) and predictions of the price increases for purchased electricity plays a vital role in any investment analysis and that, at present, is not an area in which there is much degree of agreement, let alone certainty. The investment analysis must therefore provide a satisfactory return over a wide range of possible energy price scenarios.

To maintain the efficiency of a co-generation facility, surplus electricity needs to be sold to the Electricity utility, and additional electricity purchased to cover the peaks in demand and during periods when the plant is shut down for maintenance or breakdown. An established electricity utility with little or no co-generation with industry will only be looking at paying a very small price for co-generated electricity. The avoided cost will only generally be the cost of fuel to produce that electricity. However, once a utility has a significant co-generation contribution then the avoided cost will include factors such as the deferral of power station construction and the buy back price could rise to 70-80% of the supply price. Government subsidy or intervention may well be necessary to raise the buy back rate initially and thus encourage co-generation until co-generation becomes a significant source of power for the electricity utility and its avoided cost becomes realistic. Similarly, the standby charges for peak electricity usage will be significant until there are sufficient co-generation installations to reduce the effects of any single maintenance or breakdown requirement. Once again Government subsidy or intervention may be justified.

THE SOUTH AUSTRALIAN SITUATION

As I have already said, last year the South Australian Government set up a working party to examine the existing situation, the potential and any current dis-incentives for co-generation and to make recommendations for any appropriate action.

To put South Australia - and indeed Australia - into perspective, here is a break-up of land areas and population.

South Australia covers an area of 380,000 sq. miles (984,000 sq. kilometres) roughly 12½% of the total area of Australia. Its population is 1.3 million or about less than 10% of the population of Australia. 70% of the population lives in, or around, the capital city, Adelaide.

Industry is concentrated in three areas, Adelaide, Whyalla (steel) and Mount Gambier (paper).

Total electrical generation capacity is 2090 MW of which 1280 MW capacity is from Torrens Island near Adelaide and 330 MW is located at Pt. Augusta. The Port Augusta facility is fired from indigenous brown coal deposits at Leigh Creek and a new power station to use this same fuel is being constructed nearby to provide an additional 500 MW capacity initially.

The Torrens Island Power Station burns Natural Gas from the Cooper Basin in the North East of the State and Natural Gas is also the main fuel for industry in the Adelaide area.

Of the total of 7½ million Megawatt hours generated in 1980/81 only 250,000 or 3.5% was co-generated.

The working party examining the co-generation situation has been analysing the potential for expanding this proportion. Four case studies were carried out on consumers where conditions looked favourable. The fuel and electricity price increases anticipated are comparatively predictable in the South Australian situation where the fuels are indigenous and any increases in well head gas prices will affect both the likely co-generation fuel and the price of electricity. (Over 70% of the electricity is generated from Natural Gas). The viability of co-generation projects were found to be dependent, to a critical degree, on the buy back price and standby charges imposed by the Electricity Utility.

The working party has not yet completed its report so that final conclusions and recommendations are not available at this stage.

REPRESENTATIVE CASE STUDY

Whilst, unfortunately, I am not in a position at this stage to discuss specific details of our case studies undertaken in South Australia, it would be fair to say that they disclose a common dilemma:-

1. The capital costs of modern co-generation plants show an internal rate of return of between 12 and 20%. This is equivalent to a discounted "pay back" period of 9 to 6 years respectively.
2. Fuel costs in Australia are still very reasonable compared with many parts of the world. This results in the long pay back periods. Increasing fuel costs in the future could make the projects much more attractive.
3. There is a potential problem of obtaining and maintaining operating and maintenance skills to service the higher technology needed - especially in the field of steam turbine operation.
4. The reluctance of electrical generating authorities to move from the present position of viewing tariffs is based essentially on cost of servicing capital for power stations (in other words planning capacity to meet maximum demand), and buy back rates on "avoided costs" i.e. mainly cost of fuel saved.
5. One answer that may be able to be used in your countries - is to build small power stations adjacent to industry.

The Authority could operate the generating plant and provide the heat energy (that would be otherwise wasted) across the fence - so to speak - to industry located virtually or actually next door.

This could be a future possibility in South Australia - when the next round of power station planning takes place. It is something that the South Australian Government could certainly look at.

6. This could result in the co-generation of our State being significantly increased from the present 3½% (900 Tj).
7. Capital costs of co-generation vary from around -
 - A\$900-00/KW for steam turbines
 - to
 - A\$300-00/KW for gas turbines.

The average installed capital cost can be realistically averaged at around \$600-00/KW.

8. There is a great deal of potential to utilize waste energy in a realistic way to conserve the worlds finite energy resources to a significant degree.

HOW CAN YOU BENEFIT

I hope that you will be able to benefit from looking at our situation in hindsight.

We built our Electricity generating capacity in an age of cheap energy costs and we now have our system in place. With cheap energy the capital costs associated with co-generation could not be justified. If we are to proceed with co-generation we have significant obstacles to overcome to reach a break even point for buy back and standby charges in particular.

If you have your system already in place then you may well have similar problems and the expansion of co-generation may well require government action in the short term to provide the benefits in the long term.

If you are still building up your systems, then you have the opportunity to learn from experiences ("mistakes" would be too strong a word perhaps, as few could have foreseen the rapid changes in energy prices in the last decade). You have the opportunity to build co-generation into your systems from the start and make it economically attractive. You could well be able to site industries with a large steam demand adjacent to a power station which could provide that steam.

If you can achieve significant co-generation in your systems you will be building in a buffer against the inevitable rises in fuel prices (as assuredly they will rise even if at present there is a drop). I feel sure that you will need every possible improvement in efficiency if you are to achieve a firm place in the very competitive international market in the coming years.

SUMMARY

In summary, let me say that co-generation is not new. The technology is available and proven as you will hear later in this seminar.

Co-generation offers significant improvements in efficiencies and the potential for its application is considerable.

I do not believe that it is being over-enthusiastic to say that co-generation is essential if energy costs are to be contained and industry is to be competitive in the international marketplace of tomorrow.

* * * * *

AUSTRALIA/UNIDO WORKSHOP:

WASTE HEAT RECOVERY IN INDUSTRIAL PROCESSES
28th FEBRUARY — 11th MARCH 1983 MELBOURNE

USING ENERGY MANAGEMENT CENTRES
TO IMPLEMENT NATIONAL ENERGY
CONSERVATION PROGRAMS

Mr K.J. Westall
Engineer in Charge
Energy Management Centre
Gas & Fuel Corporation of Victoria

An Energy Management Conservation Centre can provide such a vehicle.

An Energy Conservation Centre should be established to form the focal point through which all government energy conservation policies are directed.

They should be seen however, not just as a convenience for governments but of benefit to the energy consuming groups. The Centre should consider the differing needs of the Industrial, Commercial, Domestic and Transport sectors and should structure its efforts accordingly. It should recognise the critical areas and its own limitations. For example, the Transport sector is usually the largest oil consuming sector but it is also the most difficult area in which to make improvements in the short term. The industrial sector is usually a much easier area to work in because it is much more structured, already subject to government involvement through taxes etc., and is usually the area through which a fledgling Centre should first concentrate its efforts. The Commercial sector whilst not as tightly structured in that there are much larger numbers, is also an area through which early efforts should be directed because like industry uniformity exists in many of the applications and efforts and results can be categorised. The Domestic sector is the sector in which the greatest interaction will occur between social and energy policies. It is an extremely difficult area to achieve substantial reduction in use because there are usually a very large number of very small consumers and in general the people are looking to upgrade and increase their energy consumption rather than downgrade and reduce it. This is line with their expectation from the government of improved living standards.

Having considered the above, then the Energy Conservation Centre should set out to be effective, that is, it should operate in its area of expertise and in areas in which results can be achieved. It should recognise that its efforts will be divided into two forms: Short term; generally through a mix of conservation and substitution, usually by low cost, low technology methods, Long Term; by major upgrading of processes and

equipment or complete plant rebuilds, a high technology high capital process.

In the early stages, the Centre's biggest problem will be lack of data on which to base its implementation plans. In most cases, industry will be the area through which early efforts should be directed; it is usually the second largest consumer of liquid fuels and the one in which greatest potential for conservation exists. In setting out to achieve improvements in the Industrial sector it must be recognized that the government's objective is to save oil and thus reduce burden of import costs, whereas industry wants to save money. It will thus be necessary to prove to industry that spending money to improve the efficiency of energy use will result in a net saving of money to them.

In the early stages, the Centre should form a number of groups whose function it should be to go into industry to show them how to improve the "housekeeping" standards in their factories. This form of conservation effort can reduce energy consumption by around 15% for simple payback periods of investment of 6 months. The group should at the same time gather data so that a more accurate picture can be established about industry's use of energy, the age of the equipment, the level of expertise in the plants, and the potential for further improvements. The gathering of this data should be in a well structured manner so that collectively the Centre can establish a data base for the purpose of analysis and policy recommendations to governments. This data base should be based on the ISIC, that is, the International Standard Industrial Classification System and it should identify which industry groups are the largest

energy consumers, which are the most energy intensive, which have the greatest potential for improvement, which are likely to be the most receptive to efforts and what form this effort should take. For example, a cement industry may show up as the largest and most energy intensive industry; it may however already have adequate technology within its own ranks, adequate training facilities and the incentive to make improvements due to actual cost of energy. But it may simply lack the capital to make the changes to its process. In this case the role of the Centre should be to assess the value of potential savings to the nation's conservation efforts and to try to obtain or make recommendations about the provisions of funds at concessional rates from the government or development banks. In adopting this role, the Centre will be seen as a benefit to industry and not just a representative of the government anxious to get its hands on confidential industry records. It is for this reason that the structure suggested for the Centre is one which comprises both Industry and Government. It is also important that the Board of executives however, provides only policy guidelines and permits the Centre to be independent in day-to-day operation. The types of structure suggested is also aimed at freeing the Centre from the limitations often imposed on the salaries of government employees and would permit the Centre to offer the level of remuneration necessary to attract and hold enthusiastic capable, self-motivating, broad thinking people required to make the Centre a success.

The operation of the Centre should be such that its activities are totally integrated, for example, studies conducted should lead to recommendations for the improvements possible at the factory level. They should also provide the facility for data gathering and the formulation of a data base from which an understanding of industry can be achieved, they should also allow the success of efforts to be measured and the requirements and

directives of future programs and efforts, determined. The information should also provide the orientation for the thrust of any publicity campaign and the provision of financial incentives by way of tax relief or duty exemptions and dis-incentives through higher energy charges. The findings and experience of the group executing the studies should also be used for determining the educational needs, and transferring expertise to industry groups whose knowledge and skills are deficient.

The field groups should also become lecturers in the courses run by the Educational section. They will often also establish the potential for and the types of waste heat recovery equipment which could be used or maybe needed, and will also determine the scope within the Centre for the development of new equipment specifically for local use or the evaluation of commercially available equipment.

As the experience, knowledge and data base of the Centre grows, it should extend its activities to the Transport sector, it should investigate the potential for alternatives to liquid fuels possibly by LPG or Compressed natural gas, it should investigate the relationship between the vehicle population and the type of fuel produced by the refineries, the potential for optimizing yields and the likely impact of uncontrolled expansion in the use of one fuel type, for example diesel fuel

If the availability of LPG or CNG, is such that they could provide a substitute potential for gasoline use, then its use should be promoted in the most beneficial areas by the Centre in line with government policies. The Centre should ensure that the emergency services such as the Police, Fire brigade, Medical services are adequately trained to cope with the likely impact of the use of the fuels; and that the necessary skills are transferred to those people who will install the equipment and ensure proper safety standards. Often the potential for substitution can be greatly affected if people are afraid of the new fuel due to inadequate safety standards.

In the domestic sector the Centre should be active in promoting an awareness of the need for conservation and aims to demonstrate the method by which it can be achieved within this group. Often though the section of the community which is using energy based on liquid fuel is quite small and this must be recognized in the promotion which is allocated to this effort. However, an awareness by the public of the benefits of the government's conservation program will assist in its successful implementation no matter what sector it is directed at.

Presented here as an example is the recommended structure and operational mode of an Energy Conservation Centre and it assumes that a government is aware of its expenditure on imported oil, is anxious to reduce this commitment and is prepared to direct its policy initiatives through its energy authority here often called the government energy authority and prepared to establish an energy Conservation Centre jointly funded and operated by the major beneficiaries that is primarily the government and industry.

THE NEED FOR AN ENERGY CONSERVATION CENTRE

As the work involved in providing advice and guidance to industry in regard to energy conservation is considerable and is of a highly specialised nature, an institutional arrangement for facilitating energy conservation in industry is recommended. An Energy Conservation Centre is one such arrangement which could take over the task of implementation of energy conservation policies and allows the GEA to concentrate on policy formulation, analysis of aggregative data on industry sub-sectors and other major sectors of the economy, and on monitoring the results achieved by energy conservation measures.

ROLE OF THE ENERGY CONSERVATION CENTRE vis-a-vis GEA

The Centre should be the agency responsible for implementing energy conservation policies, formulated by the Government. The Centre should have full freedom to conduct its day-to-day activities in conformity with the policy guidelines of the government in regard to energy conservation. The Centre's activities should be monitored by the GEA in regard to the contribution made towards energy conservation, and in regard to the conformity of the Centre's activities to the policy guidelines.

The Centre must support the policy formulation exercise by providing the GEA with the following inputs:

- information on scope for energy conservation in different sub-sectors of industry and other sectors of the economy.
- Results of energy conservation activities undertaken by the Centre in different sectors of the economy including sub-sectors of industry.
- Suggestions regarding modifications in energy conservation policies.
- Comments on new policy proposals and also on modifications to existing policies being contemplated by GEA. These comments will be sought by the GEA from the Centre before the new proposals/notifications are submitted by the GEA to the government for approval.
- Specific suggestions regarding publicity, promotional efforts special funding, incentives etc. which in the opinion of the Centre would help further energy conservation efforts.

- Results of special studies undertaken by the Centre on its own or at the instance of the GEA.

- Comments on special studies undertaken in the GEA in regard to energy consumption and energy conservation.

In order that the experience of the Centre is available to the government in its deliberations, the Centre should be represented on government sub-committees and its agencies concerned with energy conservation.

SCOPE OF ACTIVITIES OF THE CENTRE

The Centre's activities should encompass the total energy conservation spectrum. It should however initially concentrate on the industrial sector for the following reasons:

1. The domestic and transportation sectors are diverse, large in number and likely to show results from major restructuring and regulatory controls.

2. Contribution to energy conservation from the domestic and transportation sectors over the medium term is not likely to be sizeable.

3. The large and diverse industrial sector requires special attention as regulatory measures are not suitable for this sector, and results could be better achieved through providing training and expertise to the factory personnel in energy conservation techniques.

Whilst the initial area of activity should be the industrial sector, the Centre should also plan in the near future to become active in the following areas:

- a) Better planning and implementation of a national publicity and education campaign on energy conservation.
- b) Promotion of conversion of gasoline cars to LPG use, the establishment of safety standards, training of converters, training of emergency services.
- c) Energy conservation in commercial buildings and retail establishments.
- d) Providing a forum for discussion of energy conservation in the construction industry covering residential, commercial/office and factory buildings.
- e) Providing guidance and assistance to other voluntary agencies engaged in promoting energy conservation.
- f) Provide research facilities in the field of energy conservation.
- g) Provide guidance and assistance to the colleges and universities for the establishment of energy conservation courses and relevant curriculum.

MANAGEMENT OF THE CENTRE

The Centre should be directed by a high-powered Board of Directors comprising representatives of concerned agencies of Government and representatives of the private sector connected with industry, transport construction, and also technical experts in engineering, economics, and mass communications.

The Centre's Board of Directors should have a distinguished Chairman who will preside over the Board meetings and he should preferably be a member of the Government's policy formulating group. The appointment of the Chairman by the sponsors of the Centre should be subject to approval of the Government.

The Centre should have an Executive Director appointed by the Board of Directors who will be the chief executive of the Centre and an associate director of the Board of Directors. The Executive Director should be a technical expert and should have considerable understanding of the private manufacturing sector and in modern management techniques.

The Centre should constitute an Advisory Committee consisting of experts in industry, management, training and other relevant areas to assist the Executive Director who will be the Chairman of the Advisory Committee. The Advisory Committee should meet periodically and should not be concerned with day-to-day activities of the Centre.

The Executive Director should be free to organise the various committees divisions of the Centre under the direction of the Board of Directors.

FUNCTIONS OF THE CENTRE

The main functions of the Centre shall be to provide:

- Consultancy Services
- Educational Services
- Equipment Assessment
- Publicity and Promotion
- Data Collection and Dissemination Services

Specifically the activities should include but not be limited to:

1. Conducting energy audits of industrial establishments to identify scope for energy conservation.
2. Training of factory personnel, mechanics, electricians.
3. Setting up energy management systems in industrial and commercial establishments.
4. Preparing project reports on energy saving projects for clients to facilitate provision of finance by lending agencies.
5. Preparing and implementing an Information, Publicity and Education Campaign.
6. Publication of an Energy Conservation Bulletin.
7. Developing data base for facilitating more effective planning of energy conservation activities.

8. Guiding manufacturers of energy saving equipment and instruments in regard to technical matters.
9. Providing support to the GEA in its policy formulation tasks.
10. Maintaining close contacts with the GEA, energy users and experts on energy conservation in the country and abroad in order to function as a clearing house of information on all aspects relating to energy conservation.

FUNDING

The Government should provide part of the financial support to the Centre.

The bulk of the financial contribution to the Centre should be sought from private industry which should also have the major responsibility in regard to the management of the Centre.

Financial institutions like the banks who are likely to be involved in financing major energy saving projects may also be approached to provide funds.

The agencies and organizations who provide funds should have suitable level of representation on the Board of Directors of the Centre.

This part of the report is aimed at providing some operational guidelines for the proposed Energy Conservation Centre.

OPERATION INTERACTIONS

The relationships and interactions between the centre and industry and government is indicated in Fig. 1. Principally it is recommended that the centre be permitted independent operation for its day-to-day operations. The policy and statement of directives and objectives should be provided by a Board of Directors as described earlier, who should be representative of both government and private industry. The requirements and policies of both groups should be deliberated by the Board of Directors in the formulation of the policy directives.

The centre by its operation will provide services to industry by way of training courses, and efficiency studies. The information gathered in the course of this work should be analysed and presented to the GEA in a manner which will permit them to fulfil their role as an instigator of policy recommendations to the government. Government policy decisions once made, should be carried to the Board of Directors by the GEA representatives. Any suggested modifications to these policies would be conveyed to the government via the GEA.

The needs and policies of the various industry groups would be introduced by the representatives, on the Board of Directors of the Industry Association or clubs.

FUNCTIONING OF THE CENTRE

The initial orientation of the Centre's activities towards the industrial sector will determine the staffing requirements and structure. A suggested arrangement is given in Figure 2.

It is suggested that the initial efforts be directed towards providing:

- a) A consultancy group to carry out factory studies to identify the potential for energy savings and to make recommendations for improvement by written report. The survey work should gather standard data for the purposes of later analysis.

The Division should be headed by a controlling engineer who should direct subordinate engineers and these should be formed into survey teams. The technicians should be supportive to these teams and have the responsibility for maintaining equipment in good working order.

- b) The Education Division. This division should have the responsibility to transfer practical technology on energy conservation to industry engineers and other factory personnel who have energy as their responsibility. This division should use its full time members for organization of course syllabi, course timetables, preparation of notes etc. It is important however that the field staff from the consultancy division be used as course lecturers to ensure that practical inputs to the course are achieved. The courses should be heavy on practical skills and implementation and light on theory. The field staff can permit this input. The course should relate wherever possible local case studies. The lecturing ability of the teachers must be

first class. It will almost certainly be beneficial to have all lecturers attend a course on "Techniques of Instruction". This division must also conduct regular seminars on industry-related technical topics, i.e. "Steam Use".

- c) The equipment assessment and demonstration division should aim to obtain the latest energy saving equipment available for the purposes of display in the Centre's display area. If possible, working models should be installed and regular exhibitions held. The potential for the equipment should be assessed and the value publicised. This division should also aim to engineer the first installation of a particular energy saving unit for the purposes of practical demonstration. In most cases the opportunities will be identified by the consultancy division. The need for Government demonstration project funds for this purpose should be investigated. After each demonstration project, a comprehensive report must be prepared and the major advantages and disadvantages widely publicised by pamphlet or booklet.
- d) The promotions and publication division will handle the publication of publicity material generated by the Centre and print consultancy reports and course notes. Another extremely important role for this division is the organization associated with the seminars, courses and conferences, a very professional standard is essential.

- e) Data Control. This division should ensure that data collected from the field operations is properly collated and prepared in a form most valuable to Government policy-making areas. The need for information should be both obtained and screened by this division. The informational needs of the Centre's staff will also be satisfied by this division. A sophisticated data collection, storage and dissemination system is necessary along with modern equipment.

Staffing

The following staffing requirements for the centre is anticipated;

	Function	Qualification	No. of
Executive Director	Eng. in Charge of Centre	Mech. ENG/MGR.	1
Consult. Div. Control Eng.	Control of Consult. Div.	Mech ENG Chem Prod.	1
Engineers - Consultancy	Carry out Tech. Consultancy	Mech. ENG Chem.Elec. Prod.	8
Technicians - Consultancy	Assist with Tech. Consultancy	Mech Tech. Cert.	6
Education Div. Control Eng.	Control of Education Division	Mech. ENG Chem. Prod. Teaching	1
Engineer - Education	Carry Out Education Program	Mech. ENG Chem. Prod. Elec.	2
Assessment & Demo Control Eng.	Control of Ass/Demo Division	Mech. ENG	1
Technicians - Ass/Demo	Assistance with Ass & Demo	Tech. Cert	2
Promotions Officer	Organize Promotion/Publication	Advertising/ Journalists	1
Asst. Promotions Officers	Assist w/Prom. & Publications	Organizing Experience	2
Data Control Officer	Data Storage Analysis Control	Statistical Analyst	1
Data Control Assistants	Preparation of Data Reports	Statistical Analysts	2

MOTIVATION

The Centre will need to be a highly motivated operation and for best operation the staff should be carefully chosen to ensure that they are basically self-motivating, enthusiastic, capable and have good personalities, since the degree of public interaction is high. It is important to note that the Centre is preaching modernization and efficiency--it must therefore be that itself.

ESTABLISHMENT PERIOD

It is recommended that an experienced consultant be obtained to assist in the initial establishment and operation of the centre. This assistance should take the form of direct guidance of the appointed staff in the execution of their duties. The consultant should guide the executive director in overall Centre management, the operation of the various divisions which comprise the Centre, the duties and objectives of the divisional control engineers and the various promotional, publication and data services.

This brief should be to carry the Centre from an initial formulation stage to an operational stage, a period estimated to take about one year.

STANDARDS

Industry will expect to see seminars and courses professionally conducted with great attention to fine detail - good public address systems, video display units, good lecture rooms, with conditions conducive to best learning.

The facilities of the Centre must be of high standard, telephones, typing facilities, receptionist arrangements should all be first class. Facilities for the preparation and best presentation of reports and course notes, and convenient photocopying facilities must be available. Attention to detail should be a feature of the Centre's operation.

OPERATIONAL INTERACTIONS

Figure 1

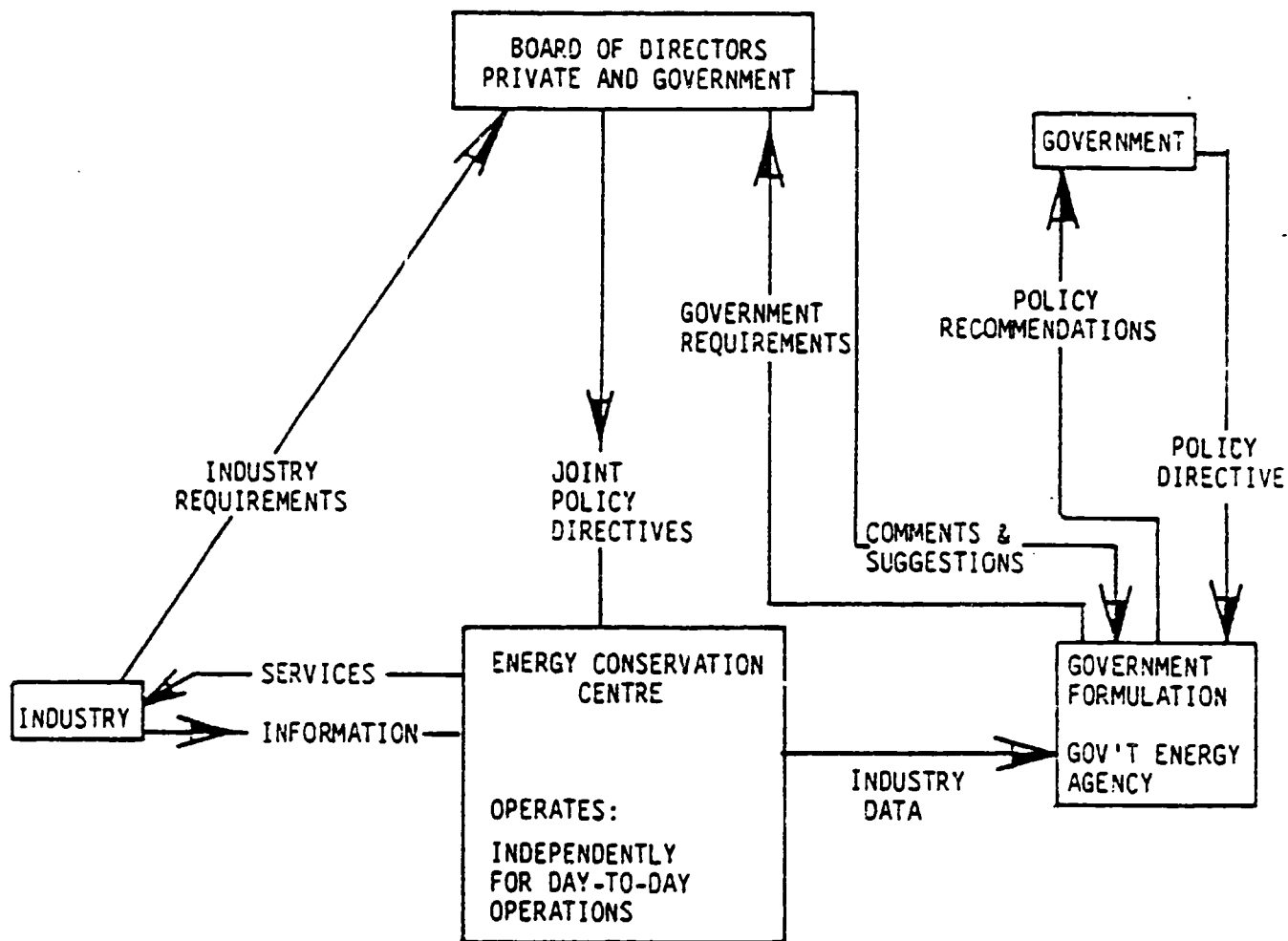

STRUCTURE OF THE ENERGY CONSERVATION CENTRE

Figure 2

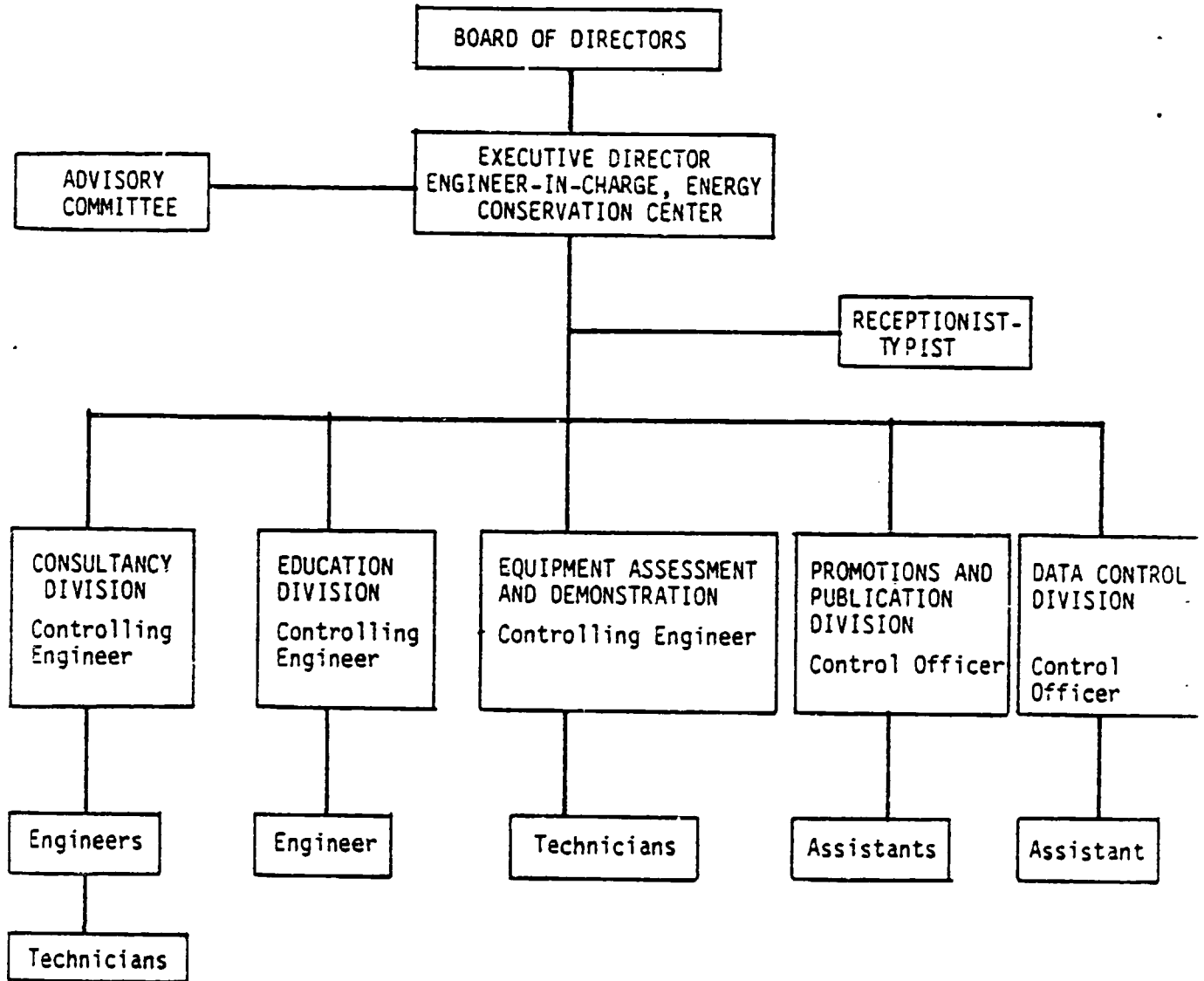

MEASURING EQUIPMENT HELD BY THE
ENERGY MANAGEMENT CENTRE FOR
USE ON CONSULTING SERVICES

UNITS	DESCRIPTION	VALUE
<u>GAS ANALYSIS & MEASUREMENT</u>		
1	Johnson & Williams Methane Detector	\$ 750
1	Teledyne O ₂ Detector 320P	1 200
1	Flue Gas Analyser 980	1 800
4	Fyrite CO ₂ - O ₂ Test Kits	2 000
5	Drager Multi Gas Detector Kits	2 500
1	Servomex O ₂ Analyser	1 200
<u>TEMPERATURE INDICATION & RECORDING</u>		
1	Foster 0-1000°C Indicator	250
1	Foster 0-1300°C Indicator	250
1	Heatrol 0-1200°C Indicator	250
2	Mini Temp Digital Thermometer	600
1	Suction Pyrometer	1 800
1	Cambridge Potentiometer	1 500
1	Leeds & Northrup Potentiometer	1 500
1	Elmes Temperature Recorder	800
2	Cambridge Filament Pyrometer	400
1	Kelvin Hughes 0-600°F Indicator	250
1	Kelvin Hughes 0-1400°C Indicator	250
1	Goerz Thermostat Temp Recorder	750

UNITS	DESCRIPTION	VALUE
<u>PRESSURE OR FLOW INDICATION & MEASUREMENT</u>		
1	Bacharach Draft Indicator	\$ 75
1	Lambrecht Air Flow Meter	800
1	Dwyer Inclined Manometer 250Pa	350
1	" " " 10"	450
2	" Pitot Tube 48"	260
2	" Pitot Tube 18"	180
1	Kurz Air Velocity Meter	600
1	S & M Vane Anemometer	300
1	Rosemount Flow Transmitter	1 200
1	F & P Precision Bore Flowrator Set	650

ELECTRICAL POWER INDICATION & RECORDING

1	Foxboro mV Recorder	1 200
1	Cambridge mV Recorder	1 200
1	Hioki 3134 Power Tester	1 500
1	Hioki 3141 Integrator	1 200
1	Hioki 8701 mV Recorder	800
3	Hioki 9008 Clamp on Probe	600
2	Fluke 8024B Digital Multimeter	500
1	Metrawatt Measuring Transducer	1 500
1	Paton mV Meter	300
1	Paton 4A meter	300
1	Waltman A meter	50
1	Siemens Kilowatt-hour meter 3 phase	100
"	" " " " 2 phase	50
1	Event Recorder	1 100
2	Goerz Multiscript Recorder	500
1	Tacar Recorder	1 500

UNIT	DESCRIPTION	VALUE
<u>MISCELLANEOUS MEASUREMENT</u>		
2	Hioki Light Meter 3421	5 500
4	Brannan Whirling Hygrometer	300
1	Lambrecht Thermo-Hygrograph	400
1	Bestobell Steam Trap Tester	1 200
1	E.I.L. pH meter	300
5	Ogden Condensate Pump Counters	1 000

AUSTRALIA/UNIDO WORKSHOP:

WASTE HEAT RECOVERY IN INDUSTRIAL PROCESSES
28th FEBRUARY — 11th MARCH 1983 MELBOURNE

HEAT RECOVERY IN DAIRY FACTORIES

Mr G.C. Cox
Chemical Engineer
Gilbert Chandler Institute
of Dairy Technology

Heat recovery is a common practise in dairy manufacturing plants around the world, especially since costs of energy increased with the oil crisis.

To approach the problems of heat recovery in the dairy industry it is necessary to understand some of the heating requirements for processing of dairy products. Most dairy products are processed at temperatures of less than 220°C, with most operations involving heat at less than 100°C; for cooking and pasteurizing of product, and cleaning of tanks, vessels and processing machines.

Table I below gives an indication of the temperature levels in various dairy processing operations

TABLE I. Temperatures required in dairy processing

Process	Maximum Temperature
Town milk	<100°C
Butter	<100°C + live steam
Milk Powders	>210°C + live steam
Cheese	<100°C
Casein	<100°C + live steam

Temperatures required during cleaning are 75°C with 95°C required for some sanitizing operations.

Electrical energy is used in dairy plants for motors on pumps, fans and lights. Significant quantities of electrical energy is used for milk cooling and in storage of finished product.

Energy use by process

There have been several studies conducted on energy use in individual dairy processes. Results from a study of the New Zealand dairy industry (74/75) are shown in Table 2.

TABLE 2. Mean energy consumption - dairy production

Product	Fuel MJ/L*	Electricity MJ/L*
Town milk	0.91	0.13
Butter	0.26	0.20
Cheese	0.62	0.70
Skim milk powder	1.68	0.90
Casein	0.85	0.44

Source: Vickers and Shannon, 1977

* litre of whole milk processed

The energy use figures as shown in Table 2 are average figures from a survey of most of the industry. These figures do not indicate the wide range of energy efficiencies which occur in industry. Harris (1982), in a recent survey on United Kingdom pasteurizing dairies found that fuel usage rates varied from 0.2 MJ/L to 2.8 MJ/L. The mean fuel usage rate of 0.94 MJ/L in United Kingdom dairies compares favourably with the average New Zealand figures.

Both U.K. and New Zealand dairies package milk in glass bottles. At these dairies significant quantities of energy is used in bottle washers.

Typical figures from Australian pasteurizing dairies are 0.35 MJ/L fuel usage and 0.13 MJ/L of electrical energy where most milk is packed in cartons.

Energy cost reduction opportunities in the industry

Significant energy and cost savings could be had throughout the industry. Recent energy audit studies in the United Kingdom have shown that energy savings of 30 to 40% are achievable in most industry sectors; savings up to 81% in some sectors were available through the improved use of existing resources, and adoption of existing technology (Grant, 1979; Currie, 1981).

Energy saving measures fall into four categories:

- good housekeeping and skilful management
- modification of existing plant
- plant replacement
- new processes

An energy audit is conducted on a plant to define the current situation, identify areas for savings, and the minimum energy-use feasible with the particular type of plant in use. These audits also enable longer term energy saving strategies to be planned.

Experience in Australia (Westall, 1981) and overseas (Grant, 1979) is that savings of 8 to 20% can be achieved by improved energy management and minor modifications to existing processes.

Additional savings of 15 to 30% can be gained within the next 20 years by the application of known technology. Success in gaining these savings will be influenced by factors such as the economics of energy conservation, pricing of fuels and energy, and the ability of organizations to fund new ventures.

1. Energy saving technologies available

1.1. Regeneration of milk pastuerizers

Milk is pasteurized to kill off pathogenic organisms and reduce bacterial numbers prior to packaging and consumption. The pasteurization is performed in a plate heat exchanger, where the milk is heated and held at 72°C for 15s and then cooled. For a typical arrangement see figure 1.

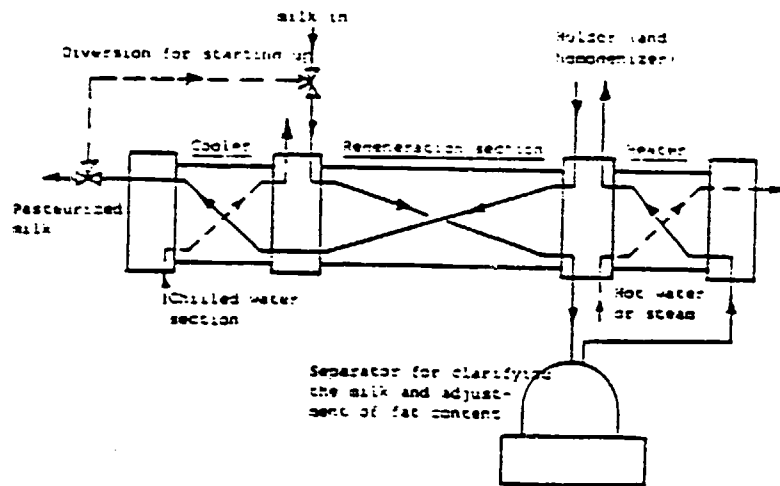
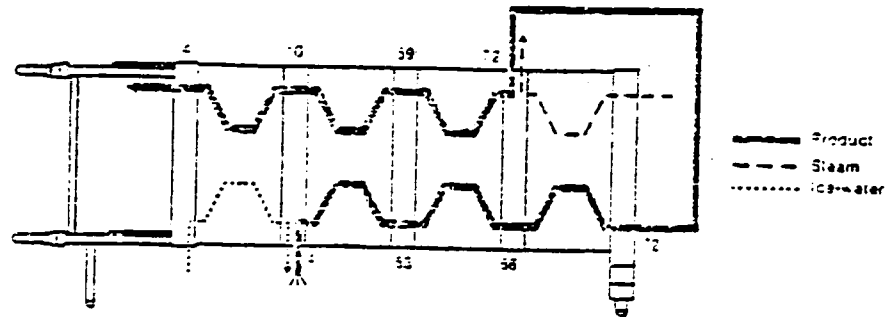

Fig. 1 Flow diagram for the pasteurization of milk



On these continuous machines heat is recovered from the outgoing hot milk in the 'regeneration' section.

Pasteurizers for fluid milk in Australian plants typically have heat recovery or regeneration figures of 85 to 88%; some early machines perform with 75% regeneration. By increasing the number of plates in the regeneration section, higher regeneration can be achieved, so less energy is used in heating and cooling. With increased energy prices, some large dairies find it economic to operate pasteurizers with over 92% regeneration.

Not all existing pasteurization plants can be successfully extended. In some obsolete types new plates are not available. Also pasteurizing plants with low pressure plates cannot withstand the higher pressures associated with high regeneration levels.

1.2. Partial homogenization of milk

Homogenization of milk is an extremely energy intensive process; about 6 kWh per 1000 litres of milk is used. A technique to reduce the energy required is to homogenize part of the milk. In one system, the whole milk is heated to 52°C and then separated to give a cream of 10-12% fat. This cream is homogenized, and remixed with the skimmed milk prior to pasteurization. As the volume homogenized is one third that of the original milk, there are significant energy savings. This process is economic where other processes also need a separator. A plant of this type is in operation in Australia (Lee, 1982).

1.3. Ultra heat treatment plants

Milk is sterilized in ultra heat treatment (UHT) plants by heating it to 140°C and holding it for a few seconds.

In the early 1970's indirect heat exchange UHT systems were able to achieve about 60% regeneration with direct systems achieving 50 to 70% regeneration (Cattell, 1981). During the 70's and 80's significant design improvements have taken place. Indirect heat exchange systems are now able to achieve regeneration of 90-95%, with commensurate improvements in energy efficiency.

1.4. Heat pumps

Heat pumps take in energy at one temperature, and raise it to a higher temperature. The heat pump can thus draw on waste heat that would otherwise be rejected and provide heat at a usable temperature. There are heat pumps undergoing demonstration trials in dairy factories in the United Kingdom and Sweden.

In the United Kingdom in a large pasteurizing dairy owned by the Milk Marketing Board, a heat pump receives water at 24°C, and provides heat at 38°C, whilst reducing the 24°C feed to 7°C (Smith, 1981). (Figure 2). A further heat pump is used to heat the water from 38°C to 60°C. This system provides a hot and cold recycled water supply. These heat pumps had average co-efficients of performance of 5.5. A payback period of 2.5 years was expected.

Schematic of 2 Centrifugal Templifier[®] Heat Pumps for Bamber - Bridge Dairy

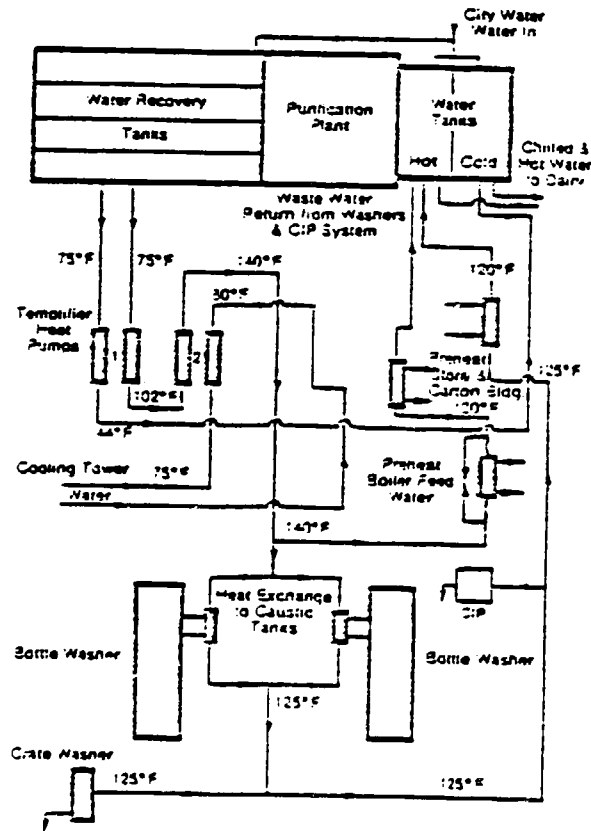
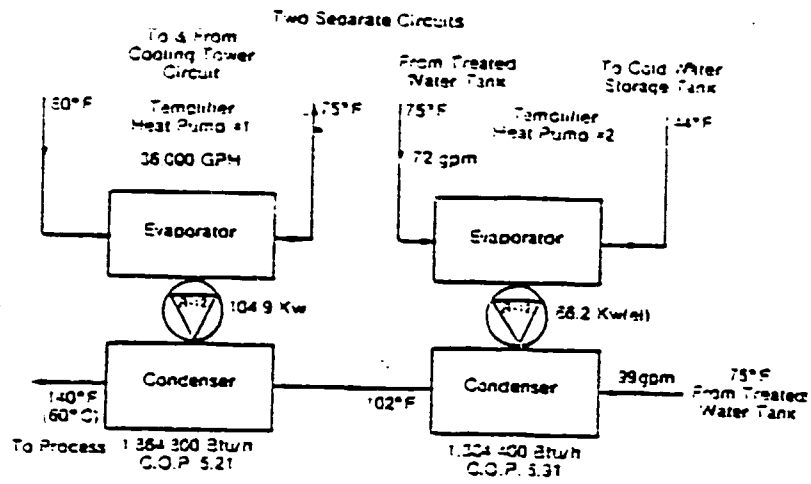

Figure 2

1.5. Evaporation

Evaporation plants installed in Australia in the 1960's were typically of the rising film, 2 stage type or of the circulation type. In the 1970's, 3 stage falling film types of evaporator were installed with specific steam consumption of 0.25 kg of steam per kg water evaporated (figure 3). More recent designs of evaporator can achieve a high level of total solids; typically 50 to 52% TS on skim and whole milk on long production runs. Milk evaporators installed in Australia in the last two years have 5 stages and a finisher, and have steam economies of 0.125 kg steam per kg water evaporated. Seven stage plants built recently in New Zealand have steam economies of 0.086 kg of steam per kg water evaporated. Existing three and four - effect plants can be modified by fitting further stages to give improved efficiencies (Van Geffen, 1977). In most cases the efficiency achieved will be less than that of a new evaporator of the same number of stages due to design compromises made.

The effective economic limit of number of stages for thermal evaporators is 8 given the temperature driving force per stage, and heat losses.

In seeking improved energy efficiencies it is necessary to use mechanical vapour recompression (MVR) systems. Typical efficiencies achieved are 8 - 12 kWh/tonne water evaporated. MVR plants can also be driven by gas motors and steam turbines. The smallest evaporator has an evaporation capacity of 12 tonne water/hour (Harris, 1982).

Vacuum production using vacuum pumps

Modern falling film evaporators utilize liquid ring vacuum pumps for vacuum production rather than steam ejectors as in older evaporators. Liquid ring vacuum pumps can be fitted to existing plants to replace the steam ejectors. Payback time for such a retrofit is less than one year, based on prevailing Victorian energy prices.

Condensate re-use

The condensate from the evaporator can be utilized directly as boiler feed water. Most evaporators fitted in the 1970's in Australia have the facility to send the condensate from the first evaporator effect to the boiler feed water tank. Other uses for condensate are supply to Clean In Place (CIP) systems, and for preheating drying air.

Several Australian dairy factories successfully use the condensate from the second and third evaporator effects, as boiler feed water and CIP feed water. However some other dairy factories discharge this same water to waste. These factories consider that the risk of milk product carry over into this condensate is high, making the water unsuitable for use in processes where it may come into contact with finished milk product. As a precaution, a conductivity meter can be used to divert contaminated water to a drain.

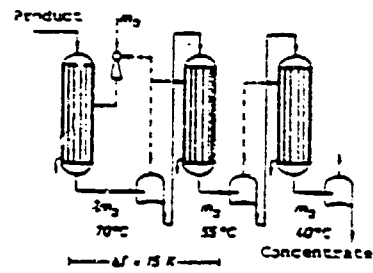

Heat consumption $m_2 / (4 m_1) = 0.25$

Fig. 3.

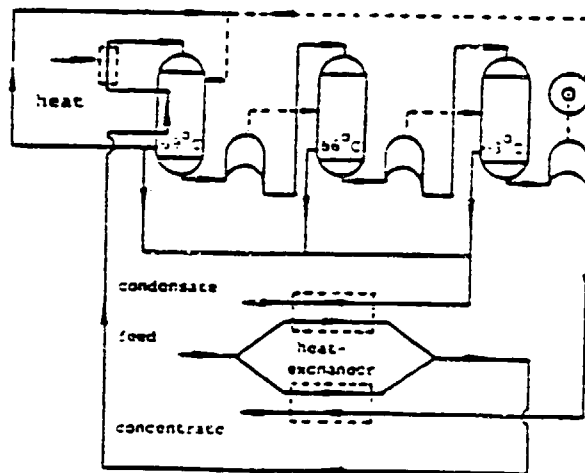

Example of a triple effect evaporating plant with mechanical vapour recompression

Various steps can be taken to improve the quality of condensate available from evaporators (Holmstrom, 1978). These include allowing aeration of product, constant steam supply pressure and cooling water temperature control.

By the use of anion and cation exchange columns followed by sterilization, the total condensate from an evaporator was used. The treated condensate was at 50°C and still has a useful energy content. In a Swedish factory the treated condensate was used for all potable uses. Based on water and energy savings, systems in Sweden had simple payback periods of 2 years.

1.6. Spray drying

Spray drying is energy intensive and uses about 15 times as much energy as an evaporator to evaporate 1 kg of water. There are several techniques which are available for improving the efficiency of the drying process. Two of these are listed below.

Two-stage drying

Milk is dried to about 88% total solids in the main chamber of the dryer. The balance of the drying takes place in a fluid bed dryer, normally to a powder moisture content of 4%. A two stage dryer (figure 4) uses about 15% less energy than a single stage dryer (figure 5). However, capital costs for a two stage dryer are about 30% higher than for a single stage system (Harris, 1982).

Direct-firing

Direct-firing of dryers allows an improvement in efficiency compared with indirect-firing systems. The system efficiency is 8% higher for direct-fired single-stage drying compared with indirect systems, and 9% higher for two-stage drying (Shebler, 1977). Direct-firing of dryers has been used in Australia since 1971, and is the generally accepted practice where economically feasible. Such systems are not suitable for drying baby foods. Both natural gas and liquified petroleum gas are used.

Heat recovery from spray dryers

Heat recovery from spray dryer exhausts is a technique which can reduce the energy consumption of the dryer by 20%. However, the problem with recovering this waste heat is the milk powder fines in the exhaust air stream. These fines can foul heat exchange surfaces, and cause bacteriological problems. In recent years several systems have been developed in Europe for recovering the waste heat and powder fines:

Wet scrubber: In this device, milk was used as the scrubbing fluid to remove most of the powder from the exhaust stream. These devices were principally powder collectors, with some heat recovery. The recovered heat was returned to the evaporator which had a much higher efficiency than the dryer. Overall evaporator/dryer energy savings of 5-10% can be expected. The milk scrubber is now not favoured as a heat recovery device in new installations, due to its relatively low heat recovery efficiency and the bacteriological problems associated with operation of this equipment.

TWO STAGE

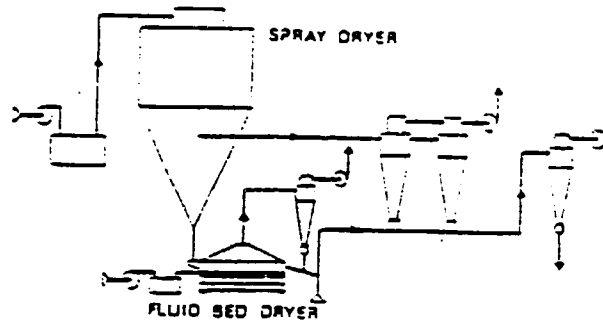

Fig. 4 Two-Stage Drying Plant.

SINGLE STAGE

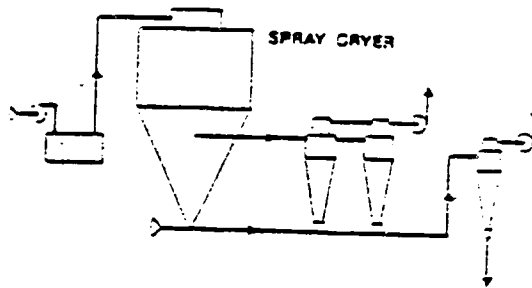
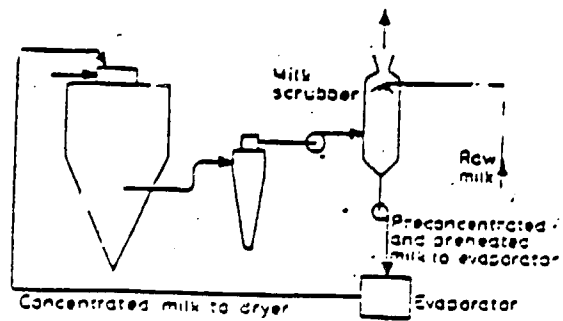

Fig. 5. Single Stage Spray Dryer.

MILK SCRUBBER



Heat pipe: A group of heat pipes are used to transfer heat from the exhaust air to the inlet air stream. A trial in the Netherlands has shown that a heat pipe system can be operated for heat recovery under certain conditions of exhaust air humidity and powder content (Jansen et al, 1981) and provide a thermal efficiency of 30% and operate 24 hours between cleaning cycles. A full scale heat pipe system with larger fin spacings was installed on a milk dryer in Ireland in October, 1980. Initial results show a 24% reduction in energy use (Donnelly, 1981).

Tubular heat exchanger: Another heat recovery device is the tubular heat exchanger. The powder laden air travels through stainless steel tubes, transferring heat to inlet air, or a heat transfer medium. Powder buildup is removed through CIP cleaning. These systems can achieve heat recoveries of 30% and are commercially available. Further, these heat recovery systems can be operated to remove both sensible and latent heat, thereby allowing condensation in the system. This presents further cleaning problems. Systems for latent heat recovery are still undergoing development.

Bag filter - heat recovery system:

For ease of heat recovery a bag filter can be fitted prior to a heat recovery device. The system can be economic where powder prices are high, or a requirement where environmental exhaust standards are stringent. The heat recovery devices fitted after a bag filter are relatively inexpensive as there is no longer a need for a system which is CIP cleanable.

1.7. Membrane processes

Membrane processes are used in the dairy industry for both water removal (reverse osmosis) and for fractionating milk (ultrafiltration). In factories, reverse osmosis can be used to pre-concentrate milk products prior to thermal evaporation. Reverse osmosis plants can achieve up to 25% total solids. The economic level of total solids is dependent on such factors as energy costs and the type of evaporator.

2. Co-generation

In these systems both heat and electrical power are produced. Various systems produce heat : power in differing ratios (Table 3).

TABLE 3. Types of plant for co-generation systems

Prime mover	Heat/power ratio
Diesel engine (or gas)	up to 3 : 1
Gas turbine	up to 3 : 1 without supplementary firing up to 15 : 1 with supplementary firing
Steam turbine	up to 15 : 1 typically high heat/power 10 : 1 low heat/power 5 : 1

Source: Grant (1979)

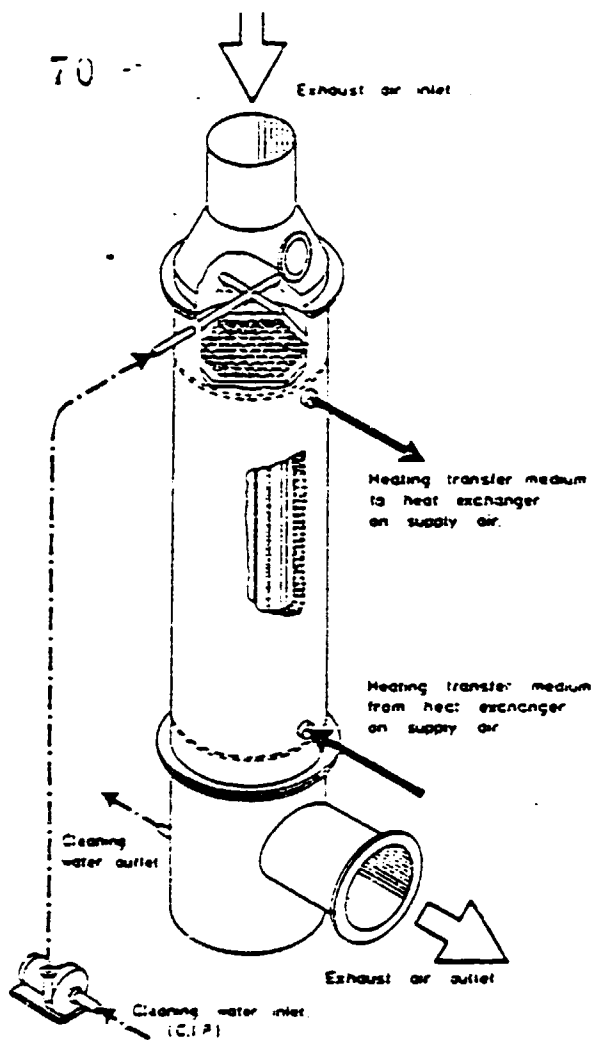

Air-to-liquid heat exchanger for recovering heat from exhaust air streams

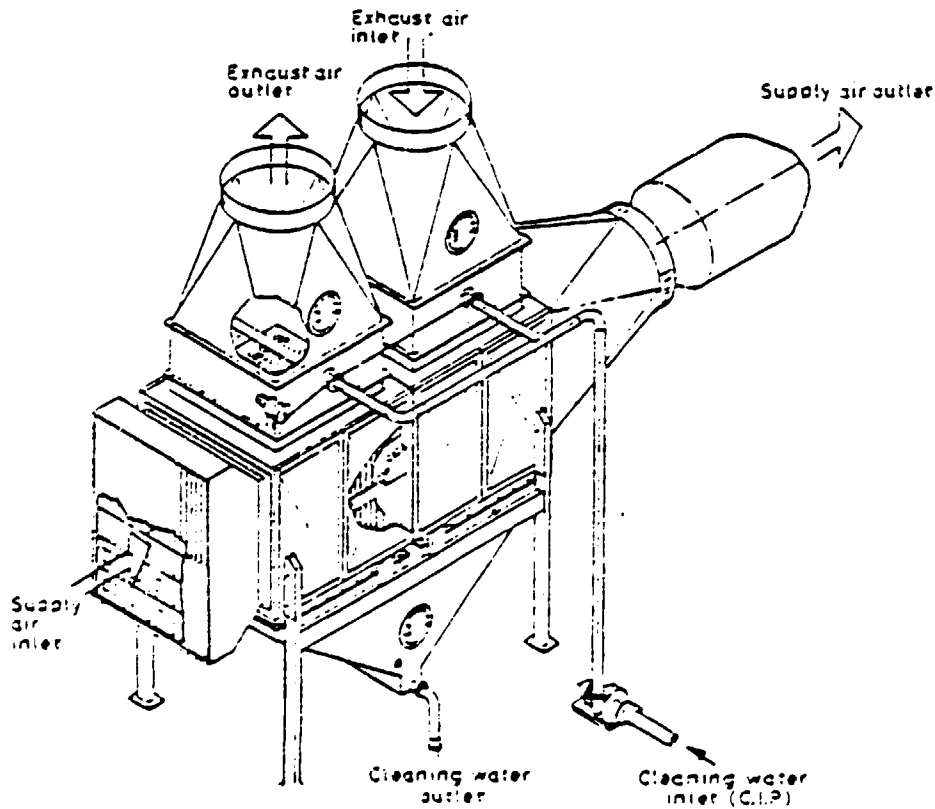
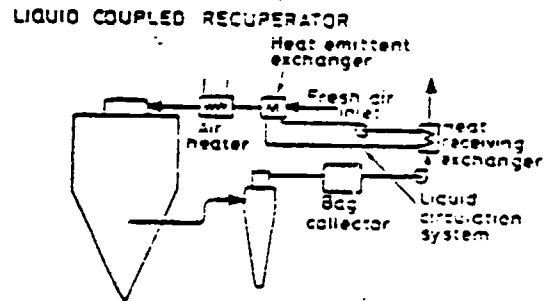
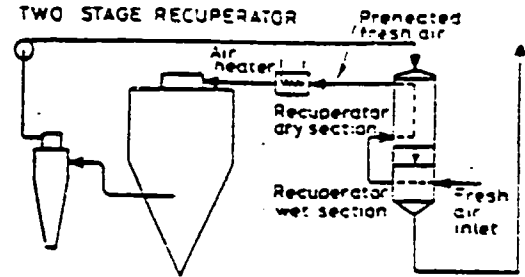
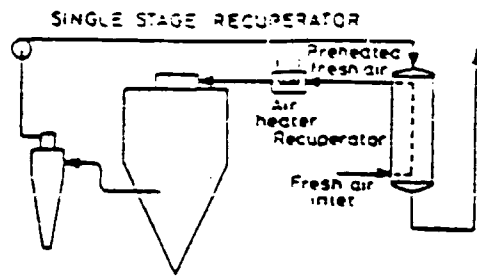

Air-to-air heat exchanger for recovering heat from exhaust air streams

Combined heat and power systems can provide energy and cost savings if both the heat and electricity can be utilized in the dairy factory. Various dairy processes have differing heat/power ratios (Table 4).

TABLE 4. Ratio of heat and power demand in the dairy industry

Sector	Heat/power ratio
Milk reception	9
Cheese	7
Powder	26
Fluid milk	16
Condensed milk	7
Other sectors	20
Average	14

Source: Jansen (1979)

With the above range of heat and power ratios, steam or gas turbines are suitable for powder plants where thermal evaporators are used. There are many factors which affect the viability of co-generation systems. These include, cost of connection to grid, standby power charges, energy costs, and availability of capital.

In a study on the viability of a gas engine co-generation system applied to a skim milk powder plant in the Netherlands, Jansen and Piersma (1981) found the rate of financial return depended on the price of electricity, fuel for the engine, and fuel saved by the generated heat.

There are several combined heat and power systems in use at large evaporator/drying complexes in the dairy industry:

- steam turbines in New Zealand (Vickers, 1971)
- gas turbines in Netherlands (Cox, 1982)
- gas engines in Netherlands (Cox, 1982)

Energy conservation

There are several further ways to improve the energy efficiency of existing dairy plants.

Boiler controls: Improvements in automated boiler controls can offer increased combustion efficiency.

General housekeeping: Checks should be made of the following areas:

- boilers and furnaces
- steam system
- insulation
- heat exchange fouling
- pumping and compression
- compressed air systems
- cooling

Comprehensive recommendations are listed in various publications; International Dairy Federation (1977), Department of Energy, United Kingdom, Energy Audit Booklets.

Other energy saving procedures include the use of hot water systems rather than steam, and using hot water systems in casein, butter and skim milk powder factories (Patchett, 1977).

Government aid

Heat recovery systems can offer significant cost reduction opportunities for industry. In many countries some form of government incentive is given for energy audits, and tax incentives for capital investments.

The Gilbert Chandler Institute of Dairy Technology, and the Australian Dairy Corporation has developed an energy conservation program for the Australian dairy industry: This will ensure that all companies benefit through knowledge of heat recovery devices applicable in Australia. Other facets of the program include demonstration projects of heat recovery devices, plus education and training programs.

AUSTRALIA/UNIDO WORKSHOP:

WASTE HEAT RECOVERY IN INDUSTRIAL PROCESSES
28th FEBRUARY — 11th MARCH 1983 MELBOURNE

COMBINED LNG & ATMOSPHERIC
GAS PRODUCTION

Mr D.J. Alder
Chief Engineer
Gas & Fuel Corporation of Victoria

Mr J.M. Shaw
Assistant General Manager
Gas & Fuel Corporation of Victoria

INTRODUCTION

The Gas and Fuel Corporation is a gas utility owned partly by the State Government of Victoria and partly by private shareholders. It provides a gas service throughout the State, mostly in the form of reticulated supply, but also in the form of liquefied petroleum gas supplied to customers' bulk storage tanks or bottles.

The principal market for reticulated gas is the State capital city of Melbourne and its metropolitan area, but the network extends also to country cities and towns. Approximately 80% of all of the residences in the State are within reach of reticulated supply.

Except for a few small country towns, reticulated areas are served by natural gas from gas wells in the Gippsland Basin offshore from the coast of Victoria in Bass Strait. The gas is brought ashore to a treatment plant at Longford, approximately 200 km east of Melbourne. The Producer is a 50-50 partnership of Esso Exploration and Production Australia Inc. and Hematite Petroleum Pty. Ltd. - a subsidiary of Broken Hill Proprietary Ltd. (BHP) - and the gas is sold to the Corporation at the boundary of the treatment plant.

From Longford the gas is carried to a City Gate located at Dandenong, roughly 30 km east of Melbourne, through a 750 mm diameter transmission pipeline 174 km long, operating at pressures up to 70 bar. A gas turbine powered booster station is located approximately mid-way along the 750 mm diameter pipeline to recompress the gas to full pipeline operating pressure.

Delivery pressure from the Dandenong City Gate into the metropolitan area is 29 bar, but some gas is immediately further reduced to 8 bar.

The Producers have a very limited right for direct sales of gas to industry and the Corporation acts as a carrier of Producer's gas for these sales and also, for gas used in the Producer's own establishments.

A most important carriage of gas by the Corporation for others is the future supply to two electricity generating stations: a 500 MW station at Newport, an inner suburb of Melbourne and a 400 MW station at Jeeralang, about 60 km towards Melbourne from Longford.

In the financial year to 30th June 1978 the Corporation supplied a total of 101 400 TJ of natural gas to 728 943 customers, comprising 62 800 TJ for industrial use, 7200 TJ for commercial use and 31 400 TJ for residential use. In addition, approximately 4900 TJ were carried for the Producers.

1. PLANNING FOR LNG STORAGE

Facilities for storage of gas in the Melbourne metropolitan area are limited and under the Gas Purchase Contract between the Producers and the Corporation the Producers are entitled to supply the total quantity of gas ordered for any day at an even rate over the 24 hours of the day. The storage capacity necessary to deal with the diurnal variations in gas demand is achieved by means of "linepack" in the 750 mm pipeline which therefore acts both as a transmission pipeline and a pressure storage facility. In both respects the load on the pipeline will increase sharply when the electricity generating loads already mentioned are supplied.

Studies were carried out to determine the optimum combination of three procedures to handle increased load, namely pipeline looping, peak shaving and interruption. At the time of these studies the arrangements for carrying gas for electricity generation were not established, but in fact, the only form of additional capacity suited to this particular load is pipeline looping and the addition of this load has simply resulted in increased and earlier provision for looping. The optimisation studies indicated an important role for peak shaving and the need for an LNG storage plant at Dandenong. No other peak shaving arrangement was seriously considered by the Corporation as the distribution system was not amenable to LPG - air addition. Estimate of capital and operating costs for various size LNG plants were prepared.

The following table summarizes the results of the 1976 optimisation studies for the six years 1980 - 1985 inclusive :-

Year	Minimum Daily Demand (MDD) TJ	Optimum Gas Supply Solution			Total capital and operating cost savings over case where full MDD supplied via pipeline (millions of \$A)
		Level of Interruption (% of MDD)	Level of Peak Shave (% of MDD)	Amount of 750 mm pipeline looping required	
1980	665	7	5	nil	2.5
1981	709	7	5	nil	2.5
1982	752	7	5	nil	3.6
1983	800	13	5	nil	4.8
1984	850	11	5	16 km	5.3
1985	896	8	5	32 km	4.4

The optimisation studies indicated a theoretical need for an LNG storage capacity less than the smallest size normally constructed, but once the economic case for storage was clearly established, with a large margin of cost saving over alternative procedures, it was decided to take advantage of the opportunity to provide sufficient LNG capacity to improve the gas supply system security and provide for failure of the gas source, or the transmission pipeline, for several days duration. A capacity of 10 000 tonne was nominated.

It was also decided to provide, again at marginal extra cost, a large reserve capacity over the calculated minimum rate for both liquefaction and revaporisation. For these purposes figures of 100 tonne per day and 100 tonne per hour respectively were adopted.

Theoretically, in terms of pipeline capacity for the combined transmission/storage function, the LNG storage is the equivalent of three pipeline loops of approximately 16 km each. This is due partly to the reduction in throughput required and partly to the opportunity LNG provided to reduce pipeline operating margins.

At the time of the studies the estimated total cost of the LNG plant was approximately \$3 000 000 - some \$10 000 000 less than the cost of constructing the equivalent three pipeline loops. This relationship was the prime reason for the decision to proceed with the project.

Since 1976 the cost of the LNG project has escalated significantly - mainly due to inflation and the technical requirements nominated by the relevant Statutory Authorities. This is to be the first LNG storage plant in Australia and at the time of the studies the Authorities had, understandably, given little thought to these matters. In fact, the LNG project cost has escalated faster than the cost of pipeline looping, thus reducing the economic advantage over the looping alternative, but to some extent this reduction has been offset by savings achieved by operating in combination with an industrial gas company (as described in the next section) and a positive economic advantage still remains. In addition, constructing the plant significantly improves gas supply security.

2. THE JOINT OPERATION

It so happened that at the time when the Corporation made its decision to proceed with an LNG plant Australia's largest producer and marketer of industrial gases, The Commonwealth Industrial Gases Limited (CIG) was planning to expand its capacity in the State of Victoria for the production of atmospheric gases - oxygen, nitrogen and argon. CIG became aware of the Corporation's plans and an approach was made to investigate the feasibility of a joint operation.

Preliminary discussions indicated significant potential advantages for both parties.

The Corporation, being a semi-Government instrumentality, felt that it should offer an equal opportunity to all industrial gas companies operating in Australia to participate in a joint operation and sought proposals from each for comparison on a competitive basis. Although considerable interest was displayed by other companies only CIG appeared to have production and other requirements which matched those of the Corporation and their proposal became the basis for the contractual arrangement now established.

In order to achieve maximum advantage from the joint operation it was considered necessary to :-

- I) Utilise LNG as a source of 'cold' for the production of the liquefied atmospheric gases.
- II) Utilise the Corporation's storage facility as a source of LNG for atmospheric gas production.
- III) Avoid unnecessary duplication of capital equipment, services etc.
- IV) Reduce unit production costs by increasing the load factor on liquefaction equipment.
- V) Take advantage of CIG's extensive experience in cryogenic gas processes.

The principal features of the contractual arrangement are :-

- I) The Corporation will construct, own and operate the LNG storage tank and facilities for re-evaporation of the LNG and re-injection into the Corporation's gas distribution system.
- II) CIG will construct, own and operate plant comprising three main sections :-
 - a) The liquefaction plant - to liquefy natural gas drawn from the terminal of the 750 mm diameter pipeline from Longford.
 - b) An interchanger where LNG is used as a source of 'cold' to produce liquid nitrogen (LN).
 - c) A low pressure air separation unit (ASU) to produce gaseous nitrogen and liquid oxygen and argon and which uses liquid nitrogen to provide cooling and includes bulk storage for liquid oxygen, nitrogen and argon.
- III) The CIG plant will be constructed on land leased from the Corporation adjacent to the Corporation's LNG storage and revaporisation facility.
- IV) LNG for use in the interchanger will be available from the Corporation's storage facilities, part of which normally will be dedicated to this purpose.
- V) After passage through the interchanger, natural gas in the vapour phase will be recompressed by CIG for re-injection into the Corporation's gas distribution system.

After adjustment to allow for the joint operation requirements the plant capacities finally adopted were :-

For the LNG liquefaction facility - 150 tonne per day

For the LNG/LN interchanger - 100 tonne per day of LNG to liquefy 200 tonnes per day of nitrogen (100 tonnes per day to product storage, remainder to ASU for cooling duty)

For the ASU facility - 100 tonne per day liquid oxygen

- 3.5 tonne per day liquid argon

For the LNG storage facility - 12 000 tonnes

For the LNG revaporisation facility - 100 tonnes per hour

The Corporation will supply CIG with filtered natural gas from the terminal of its Longford/Dandenong pipeline at pressures ranging from 31 to 70 bar. No charge will be made for the gas, but CIG is obliged to liquefy the gas, to operate its plant with a minimum of gas loss and to deliver back to the Corporation LNG which contains no substances not in the original gas. CIG may use liquefied natural gas direct from the liquefaction plant, or withdrawn from storage, for the purpose of operating the interchanger and will return the vaporised LNG to the Corporation at sufficient pressure for re-injection into the gas distribution system downstream of the City Gate.

Conceptually, the 12 000 tonne LNG storage provides 10 000 tonne for use by the Corporation and 2000 tonne for use by CIG, but at all times the Corporation has priority over CIG for the use of LNG. The Corporation will place monthly orders for the amount of gas to be liquefied and can require delivery at rates up to 100 tonne per day although CIG may deliver at a greater rate - up to 150 tonne per day. Orders must be for not less than 1000 tonne or ten days operation, to avoid excessive plant start-up and shutdown and an annual maintenance closure of 15 days is allowed. There is provision for LNG ordered, but not delivered in any month to be delivered at future times, or in extreme circumstances, for the Corporation to take over operation of the plant if necessary to avoid interruption to its gas supply operations.

Separate pumps will deliver LNG from the storage to Corporation re-vaporisation facilities and to CIG's interchanger. CIG has the right to take LNG from storage at rates up to 110 tonne per day.

The maximum pressure required for gas delivery into the LNG plant is 42 bar and the Corporation can accept some gas into its distribution system downstream of the City Gate at 8 bar. Thus there will be a considerable amount of energy available from the expansion of gas and maximum use will be made of this for electricity generation to supplement the power to be supplied for the operation of the complex from the State electricity grid, while the cold expanded gas will provide some refrigeration to assist gas cooling for liquefaction.

The Corporation will pay CIG for the gas liquefaction service, firstly by a rental charge related to the capital cost of the liquefaction plant and secondly by a charge on each net tonne of LNG delivered which is related to the plant variable cost. For the above purpose the capital cost of the liquefaction plant will not be its actual cost, but a lower figure which takes into account the savings the parties achieve by combining their plants instead of building separately. In setting up the arrangements for construction open tenders were called for the liquefaction plant to ensure a proper cost basis. The Corporation also called open tenders for the LNG storage and vaporisation facilities and the same procedure was adopted by CIG in relation to the interchanger and ASU unit.

At the end of the 15 year contract period the contract may be renewed, or CIG may remove the plant, or the Corporation may purchase the plant.

7

The agreement provides for close operational co-ordination between liquefaction and storage and the plant instrumentation is interconnected to ensure safe operation, for example, to prevent over-filling of the storage; and each party has rights of inspection of the other's facilities. CIG will control the pump delivering LNG to the interchanger, but all tank operations, including maintenance of all pumps will be under Corporation control as operators of the storage. Both plants will be continuously manned - CIG's operators controlling the liquefaction, interchanger and ASU plants and tanker loading of air products and Corporation personnel operating the LNG storage and revaporisation equipment.

The establishment of a joint operation will result in substantial operational and cost advantages to both parties. The combination was possible because of a match between the production requirements of the two organisations and the availability of a single site having geographic and technical features suitable to both operations. The use of LNG to provide refrigeration for air separation, the sharing of site utility and other services and the improved load factor on the LNG plant will reduce costs well below those for separate plants. Both parties will benefit from a sharing of the reduction in costs and their involvement in a flexible scheme using proven technology. The Corporation will gain the assistance of a partner experienced in cryogenic plant construction and operation and the benefit of a higher delivery rate of LNG, while CIG will benefit from the availability of a very large store of refrigerant material and a simplified production process.

The total capital cost of the combined scheme will be approximately \$30 000 000 Australian, with each party contributing about half. In the Corporation's case this is more than the original estimate of cost of providing its own total LNG facility, but the actual cost has escalated greatly because of the effects of inflation over the intervening period and changes in the technical requirements of the relevant Government Regulatory Authority from those assumed in the original estimates. Although greater than the original figure, the Corporation's investment will still be considerably less than if it had acted alone or adopted other means of meeting its increased gas demand.

Figure 1 is a simplified diagram of the combined scheme.

3. THE SITE

Having regard for the intended duty as a combined peak shaving and security storage facility, it was necessary to locate the LNG plant close to the Melbourne metropolitan area and within reasonable reach of suitable points for withdrawal of gas for liquefaction and re-injection for peak shaving and other purposes. The Corporation already owned a large area of land at Dandenong which included the City Gate installation. This proved to be suitable and superior to all other alternatives for the following reasons :-

- I) The Corporation land was approximately 800 metres square and although it accommodates other facilities it was possible to locate the LNG storage and associated facilities with adequate clearance distance to the boundary and other installations.
- II) Connection distances to the gas system are minimal.
- III) Because of the large volume of gas passing through the City Gate the blending of gases with minor differences in characteristics - particularly calorific value - during peak shaving will not constitute a problem.
- IV) The City Gate is continuously manned and the normal operation of the Corporation's section of the LNG facility will be safely supervised without the employment of additional personnel. CIG's plants will also be continuously manned.
- V) Because the gas for liquefaction is derived directly from the terminal of the Longford to Dandenong pipeline a significant proportion of the energy required for plant operation can be obtained from gas expansion; in addition, the cooling effect during expansion contributes to the refrigerating process.
- VI) The surrounding land is zoned for industrial use and agreement has been obtained that the zoning will not be changed to residential. Thus the boundaries of the land are a long distance from any dense residential development.

4. THE LIQUEFACTION, INTERCHANGER AND ASU UNITS

CIG commissioned Cryoplants Ltd. of the UK on a consultancy basis to assist with the feasibility study for these plants.

Four possible basic means of integrating the duties of natural gas liquefaction and air separation were considered :-

- I) Liquefaction of natural gas alone in the main liquefaction plant, with liquefaction of nitrogen against evaporating LNG in a separate interchanger as required.
- II) The reverse of case (I) namely liquefaction of nitrogen alone in the main liquefaction plant, with liquefaction of natural gas against evaporating nitrogen in a separate interchanger as required.
- III) Liquefaction of either natural gas or nitrogen as alternative duties of a single liquefaction plant.
- IV) Co-liquefaction of natural gas and nitrogen in parallel streams in a single liquefaction plant.

For safety reasons oxygen and hydrocarbons would not be processed in the same unit so that in all cases liquid oxygen would be produced separately by interchange with evaporating nitrogen.

Approaches (III) and (IV) were both eliminated, essentially because the thermodynamic properties of nitrogen and natural gas are substantially different and any cycle designed for efficient liquefaction of one would not efficiently liquefy the other. In addition, scheme (III) suffers from the disadvantage of much higher capital costs while scheme (IV) is essentially impractical because of the variable and unpredictable nature of the pattern of demand for LNG.

Approach (I) was preferred to (II) because the economic advantages of a combined scheme largely depend on running the LNG plant at full load for extended periods to maximise operating efficiency. To achieve this using scheme (II), substantial additional liquid nitrogen storage would be required to provide sufficient flexibility to meet the full range of demands for both parties, whereas in scheme (I) this flexibility is provided at much less cost by the LNG storage tank. Moreover, the operating cost advantage of a joint operation for air separation depends largely upon producing liquid nitrogen at a lower net power consumption than in conventional liquid nitrogen production plants. This is achieved by using a mixed refrigerant process (MRC) which has a significantly lower power consumption than a nitrogen expansion cycle and a higher efficiency when liquefying natural gas, for which it is well proven, than for nitrogen liquefaction.

4.1 THE LIQUEFACTION PLANT

The liquefaction plant was designed for a natural gas feed at 42 bar and 300 K with the following typical composition :-

Methane	90.14 mol %
Ethane	6.46
Propane	0.61
1-Butane	0.06
n-Butane	0.07
1-Pentane	0.02
n-Pentane	0.02
C ₆₊	0.03
Nitrogen	0.76
Carbon Dioxide	1.81
Oxygen	0.02

Maximum levels for carbon dioxide, sulphur compounds, water and benzene were assumed for design purposes.

The LNG product has to conform to the same major specifications as the feed gas i.e. gross calorific value 36.50 - 40.95 MJ/m³ (st) and Wobbe Index 46.00 - 50.80 MJ/m³ (st) and the nominal product composition was taken as -

Methane	94.00 mol %
Ethane	4.89
Propane	0.25
Nitrogen	0.86

The plant uses the MRC cycle, a cascade refrigeration principle with a single multicomponent refrigerant and a series of five partial condensation steps. The refrigerant is a mixture of nitrogen, methane, ethylene, propane and butane. To avoid blockage in the low temperature system a heavy hydrocarbon fraction is separated from the natural gas. Figure 2 is a simplified diagram of the liquefaction plant.

Referring to Figure 2, the natural gas feed is regulated to 42 bar and any condensate is then removed. The let-down portion of the gas, about 70% of the total input, then passes to a water removal unit before entering the expansion turbine and exhausting via a heat exchanger (where it provides about one eighth of the cooling required for liquefaction) to the distribution system at 8 bar. The gas to be liquefied passes to an amine carbon dioxide removal unit and molecular sieve water removal unit before entering the cold box where it is progressively cooled and condensed. Some condensate portions (e.g. benzene) are removed to prevent subsequent plant blockage and/or to adjust product composition. The gas is finally totally condensed, subcooled, measured and reduced in pressure for discharge to the LNG storage. No LNG transfer pumps are used and no flash is expected at storage tank conditions. It is envisaged that the plant will normally be run at maximum load, but it can be turned down to 70%.

4.2 THE ASU PLANT

The ASU plant is designed to produce the following products :-

Liquid oxygen - (99.5% minimum) up to 100 tonne per day

Nitrogen gas - (10 vpm O₂ maximum) up to 140 tonne per day

Liquid argon - (0.5% N₂ maximum) up to 3.5 tonne per day
(5% O₂ maximum)

Referring to Figure 3, which is a simplified diagram of the ASU plant, compressed air from the air compressor is purified and cooled in reversing heat exchangers. It is then separated in a double-column rectification system into liquid oxygen and argon products and gaseous pure and waste nitrogen. The bulk of the refrigeration for the plant is provided by injection of nitrogen liquefied in the LNG/LN interchanger; the remainder is provided by an air expansion turbine.

Refrigeration for the production of liquid oxygen is achieved mainly by liquefying nitrogen from both the high and low pressure columns in the LNG/LN interchanger system and returning it to the low pressure column as reflux. The air expansion turbine produces some refrigeration from the balancing air stream of the reversing heat exchanger and allows the plant to be cooled down in a conventional fashion at startup.

Atmospheric air is drawn into the plant through a filter and compressed to about 7 bar by a turbo compressor. The air is then cooled and washed in the direct cooler and delivered to the reversing heat exchanger system. This system cools the air to about 100 K by continuous heat exchange with outgoing waste nitrogen and gaseous products. Carbon dioxide and water vapour in the air are deposited on the surface of the air passages of the plate-fin type heat exchanger and resublimed into the waste nitrogen stream on automatic changeover.

Air from the reversing heat exchangers then passes to the high pressure section of the rectification column where it is separated into an oxygen-rich bottom liquid product and nitrogen top product, part of which is condensed in the condenser-reboiler by heat transfer from liquid oxygen in the sump of the low pressure column. Some of this liquid nitrogen serves as reflux for the lower column and the rest is joined by liquid nitrogen from the interchanger and then subcooled before being expanded into the top of the low pressure column as reflux. The uncondensed nitrogen vapour passes via the nitrogen heater and reversing heat exchangers to the interchanger system for liquefaction.

The rich liquid collecting in the sump of the high pressure column is purified to remove any hydrocarbon traces, subcooled and expanded via the argon column reflux condenser into the low pressure column as feed. The air is separated in this column into gaseous and liquid oxygen bottom products, the liquid being removed and pumped to storage and pure and waste gaseous nitrogen top products. The pure nitrogen passes to the interchanger system for liquefaction as part of the nitrogen cycle while the waste gas passes through the subcooler, nitrogen heater and reversing heat exchangers to atmosphere. Argon is produced in a separate column as indicated in Figure 3.

4.3 THE LNG/LN INTERCHANGER

The LNG/LN interchanger system, which is shown in Figure 4 and has a capacity of 200 tonne/day of LN, produces liquid nitrogen product for storage and also provides the ASU plant with refrigeration extracted from the LNG for liquid oxygen production via the nitrogen cycle. Only nitrogen is used in the interchanger system and the nitrogen pressure is always greater than the natural gas pressure to eliminate the possibility of contamination of the air products with hydrocarbons. The interchanger system receives pure nitrogen from both the high and low pressure sections of the rectification column in roughly equal amounts. Both streams are compressed to 25 bar, cooled and liquefied against LNG; the liquid is then subcooled by partial flashing. The natural gas which is vaporised is compressed to 29 bar for re-injection to the distribution system while about half the liquid nitrogen passes to storage and half to the ASU plant.

4.4 THE COMBINED PLANT SYSTEM

The liquefaction and ASU plants, linked by the LNG storage and LNG/LN interchanger, will constitute an effective integrated facility in terms of capital and energy utilisation. The fact that the product demand is not in balance, i.e. there will be spare liquefaction capacity for gas supply purposes as in any peak shaving scheme and the combined scheme can utilise this spare capacity to produce LNG for air refrigeration purposes, with the LNG storage providing a buffer reserve of cold for air separation, made the project feasible and will result in substantial energy savings: the total installed external power requirement of the above combined scheme will be only about two thirds of that which would apply for separate plants, i.e. a Corporation owned 150 tonne/day LNG plant plus a CIG 200 tonne/day liquid products ASU plant at a different site.

5. LNG STORAGE AND REVAPORISATION PLANT

After carrying out a study of world practice the following was originally adopted as a basis for design of the storage vessel :-

Above-ground tank of conventional design and construction in accordance with American Petroleum Institute (API) Standard 620 with a single bottom connection and an internal shut-off valve.

Minimum Design Standard National Fire Protection Association (NFPA) 59 A - 1975.

A conventional earthen dyke with a sump of capacity sufficient to hold the NFPA "one hour design spill".

The Corporation engaged Fluor Australia Pty. Ltd., to act as general engineering consultants for the storage and revaporisation facilities and in addition, to ensure that the public and adjoining facilities were adequately safeguarded, University Engineers Inc., (now renamed Energy Analysts Inc.) of Norman, Oklahoma were engaged as specialists to calculate vapour dispersion and heat radiation from fires resulting from spills of various sizes and to make appropriate recommendations for overall safety.

In accordance with local practice, an Environmental Assessment Statement was prepared and advertised through the appropriate State Government Ministry for objection or comment. No objections were received and accordingly, thereafter it was necessary to deal only with the two Regulatory Authorities whose normal responsibilities embrace the setting and policing of engineering standards for such installations.

There was agreement with the appropriate Regulatory Authority that for this site it was desirable to restrict the maximum allowable boundary heat flux in the event of catastrophic LNG spill and fire below the limit nominated in NFPA 59 A, but delay was experienced in reaching agreement on an actual figure and on vapour dispersal requirements.

4.4 THE COMBINED PLANT SYSTEM

The liquefaction and ASU plants, linked by the LNG storage and LNG/LN interchanger, will constitute an effective integrated facility in terms of capital and energy utilisation. The fact that the product demand is not in balance, i.e. there will be spare liquefaction capacity for gas supply purposes as in any peak shaving scheme and the combined scheme can utilise this spare capacity to produce LNG for air refrigeration purposes, with the LNG storage providing a buffer reserve of cold for air separation, made the project feasible and will result in substantial energy savings: the total installed external power requirement of the above combined scheme will be only about two thirds of that which would apply for separate plants, i.e. a Corporation owned 150 tonne/day LNG plant plus a CIG 200 tonne/day liquid products ASU plant at a different site.

5. LNG STORAGE AND REVAPORISATION PLANT

After carrying out a study of world practice the following was originally adopted as a basis for design of the storage vessel :-

Above-ground tank of conventional design and construction in accordance with American Petroleum Institute (API) Standard 620 with a single bottom connection and an internal shut-off valve.

Minimum Design Standard National Fire Protection Association (NFPA) 59 A - 1975.

A conventional earthen dyke with a sump of capacity sufficient to hold the NFPA "one hour design spill".

The Corporation engaged Fluor Australia Pty. Ltd., to act as general engineering consultants for the storage and revaporisation facilities and in addition, to ensure that the public and adjoining facilities were adequately safeguarded, University Engineers Inc., (now renamed Energy Analysts Inc.) of Norman, Oklahoma were engaged as specialists to calculate vapour dispersion and heat radiation from fires resulting from spills of various sizes and to make appropriate recommendations for overall safety.

In accordance with local practice, an Environmental Assessment Statement was prepared and advertised through the appropriate State Government Ministry for objection or comment. No objections were received and accordingly, thereafter it was necessary to deal only with the two Regulatory Authorities whose normal responsibilities embrace the setting and policing of engineering standards for such installations.

There was agreement with the appropriate Regulatory Authority that for this site it was desirable to restrict the maximum allowable boundary heat flux in the event of catastrophic LNG spill and fire below the limit nominated in NFPA 59 A, but delay was experienced in reaching agreement on an actual figure and on vapour dispersal requirements.

At this time, the U.S. Department of Transportation, Office of Pipeline Safety Operations, released its Advance Notice of Proposed Rule Making, 49 CFR Part 193 "LNG Facilities: Federal Safety Standards" and although it was recognised that this was not yet an established Standard, the proposals therein naturally influenced the Regulatory Authority dealing with these questions. The Authority then engaged the services of A. D. Little Inc., of Boston, USA to assist in the decision making process.

Finally, it was decided that a maximum heat radiation criterion of 14.7 MJ/h/m^2 at the property boundary should be adopted for the catastrophic spill case after making allowance for atmospheric radiation absorption and assuming that the flame was being blown by a 32 km/h wind directly towards the closest property boundary. When the A. D. Little computer programme was used to check the design, a reduction of the bund surface area was shown to be necessary to satisfy this criterion.

As a result, the storage tank which is of 45m diameter, will be surrounded by a reinforced concrete dyke 70m in diameter, high enough to hold 120% of the LNG storage capacity and with backfill against the outside of the wall to a height greater than the level represented by 100% tank capacity. The bund contains a sump which would hold liquid discharged from the LNG pumps for twenty minutes at the maximum pumping rate before the liquid level reached the bottom of the sloped base of the general dyke area. The base of the dyke and all of the sump will be lined with insulating concrete to reduce the rate of vaporisation and spread of flammable vapour in the event of spillage.

An extensive system of gas leak detectors coupled to plant shutdown and alarm devices is being provided together with LNG spill level detectors in the sump and dyke. In case of catastrophic LNG spill, manual and automatic vapour ignition is being provided together with extensive fire control and fire fighting equipment.

Also, as a result of A. D. Little's advice it was decided to amend the LNG storage tank design to eliminate the bottom outlet with internal shut-off valve and to adopt instead in-tank submerged LNG pumps. There will be no outlets from the inner tank below the maximum LNG level.

Under Victorian law this LNG tank, which is an orthodox double wall aboveground metal tank, is classed as a pressure vessel and as such is subject to the approval of the second Regulatory Authority whose responsibility embraces boilers and pressure vessels.

The critical factor in the determination of wall thickness for the lower rings of the tanks was the seismic load design criterion. It was originally considered that in view of this margin in wall strength and the Corporation nomination of 100% radiographic testing of all inner tank shell welds, that full height hydrostatic testing would not be necessary and a test level of 78% of maximum LNG level would be adequate. However, the finally agreed design provides for full height hydrostatic testing and the lower rings of the inner tank and concrete ring foundations have been strengthened accordingly.

The main LNG pumping system comprises three 50% capacity submerged units which will deliver at 29 bar to two 50 tonne per hour submerged-combustion type vaporisers, the revaporised gas passing direct to the distribution system. A separate smaller submerged pump will deliver LNG to the interchanger and there is provision for a road tanker loading pump if required in future.

CONCLUSION

The particular circumstances of this installation created some unique design problems. There was the need to take maximum advantage of the opportunities for economy presented by the joint operation, but a cautious approach to safety was required on the part of all concerned and this significantly affected some of the basic design decisions. This will be the first LNG storage in Australia and there were naturally various opinions on the hazards involved and means of reducing these to an acceptable level. The result, we believe, will be a sound and safe installation.

ACKNOWLEDGEMENTS

The authors are grateful to the Chairman of The Gas and Fuel Corporation of Victoria, Mr. N. A. Smith for his support and encouragement in preparing this paper and also, to colleagues Messrs. R. B. Dun and P. C. Sharpin for their valuable assistance. The assistance of CIG and Cryoplants, in making available details of their plant, is also gratefully acknowledged.

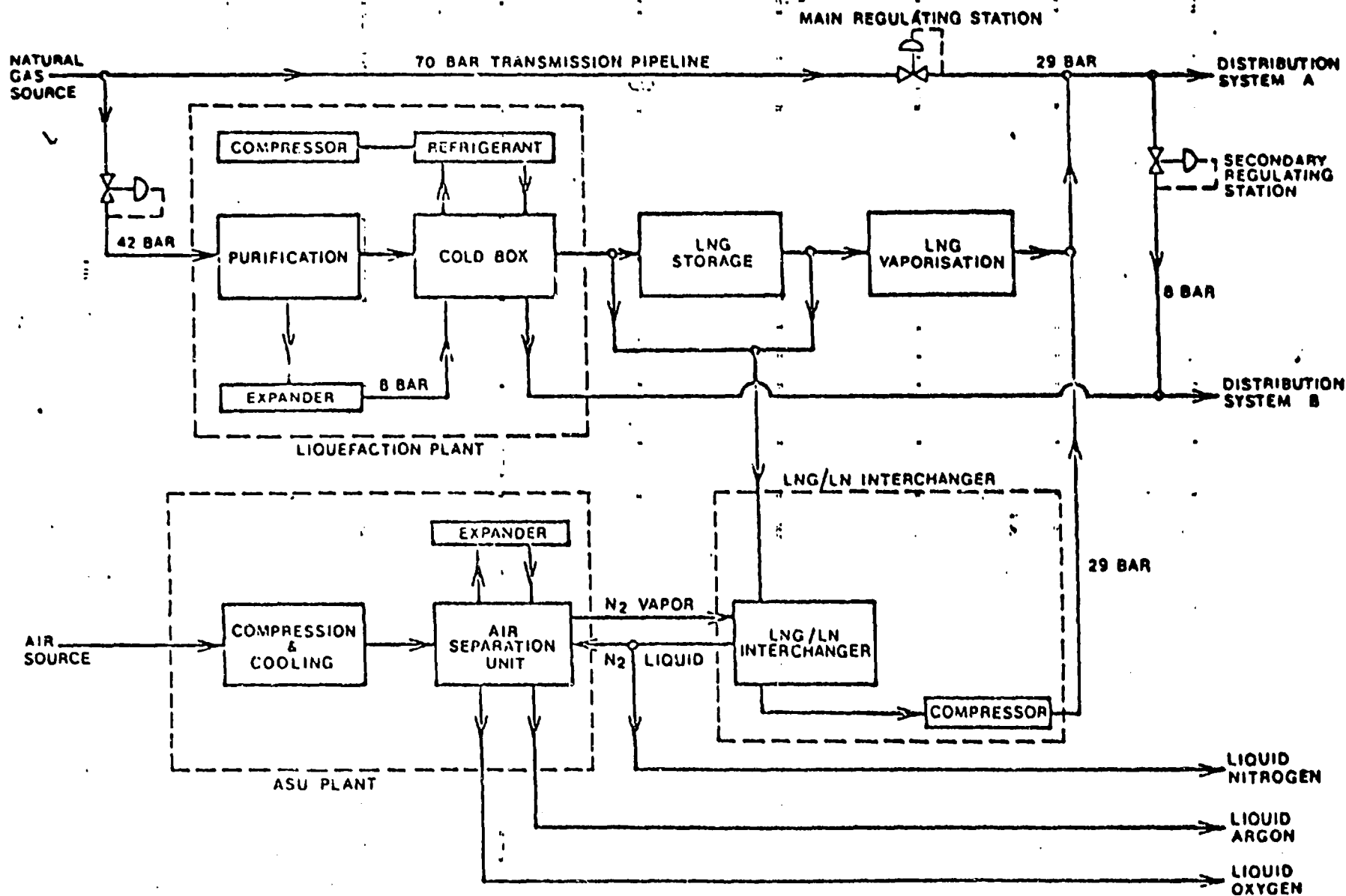

FIGURE 1: DIAGRAM OF NATURAL GAS LIQUEFACTION AND AIR SEPARATION SCHEME

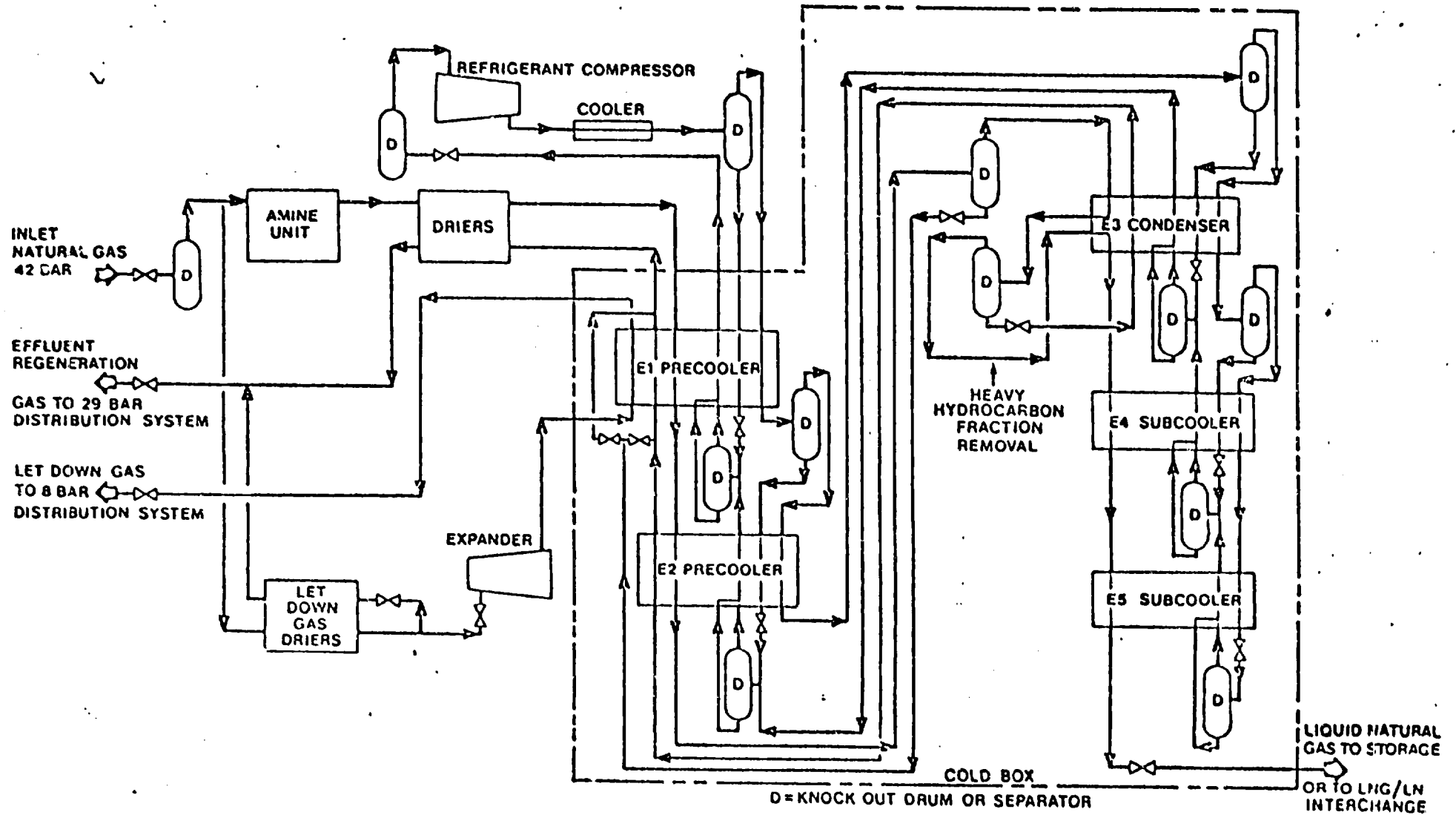

FIGURE 2: FLOWSHEET OF NATURAL GAS LIQUEFACTION PLANT

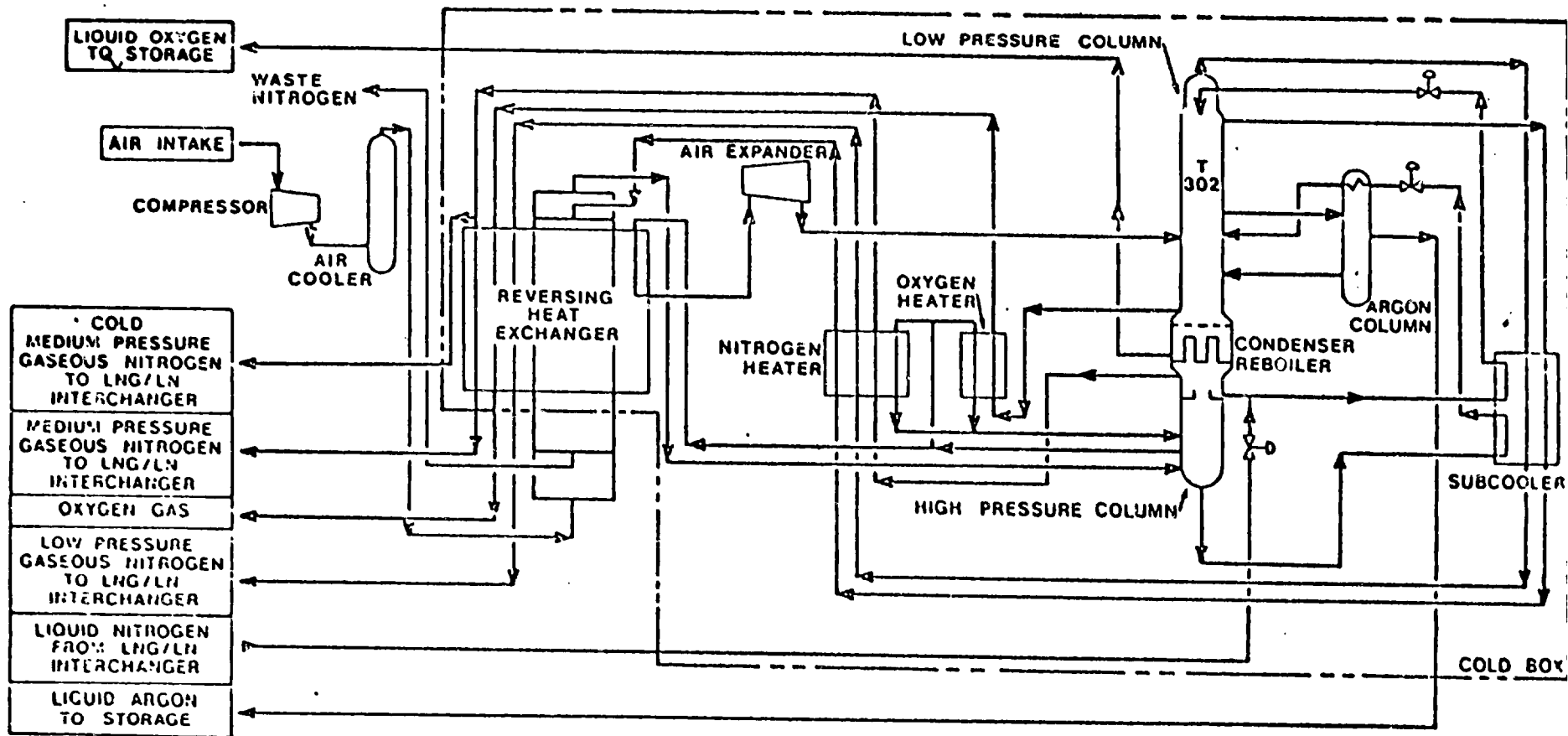

FIGURE 3: FLOWSHEET OF LOW PRESSURE AIR SEPARATION PLANT (A.S.U.)

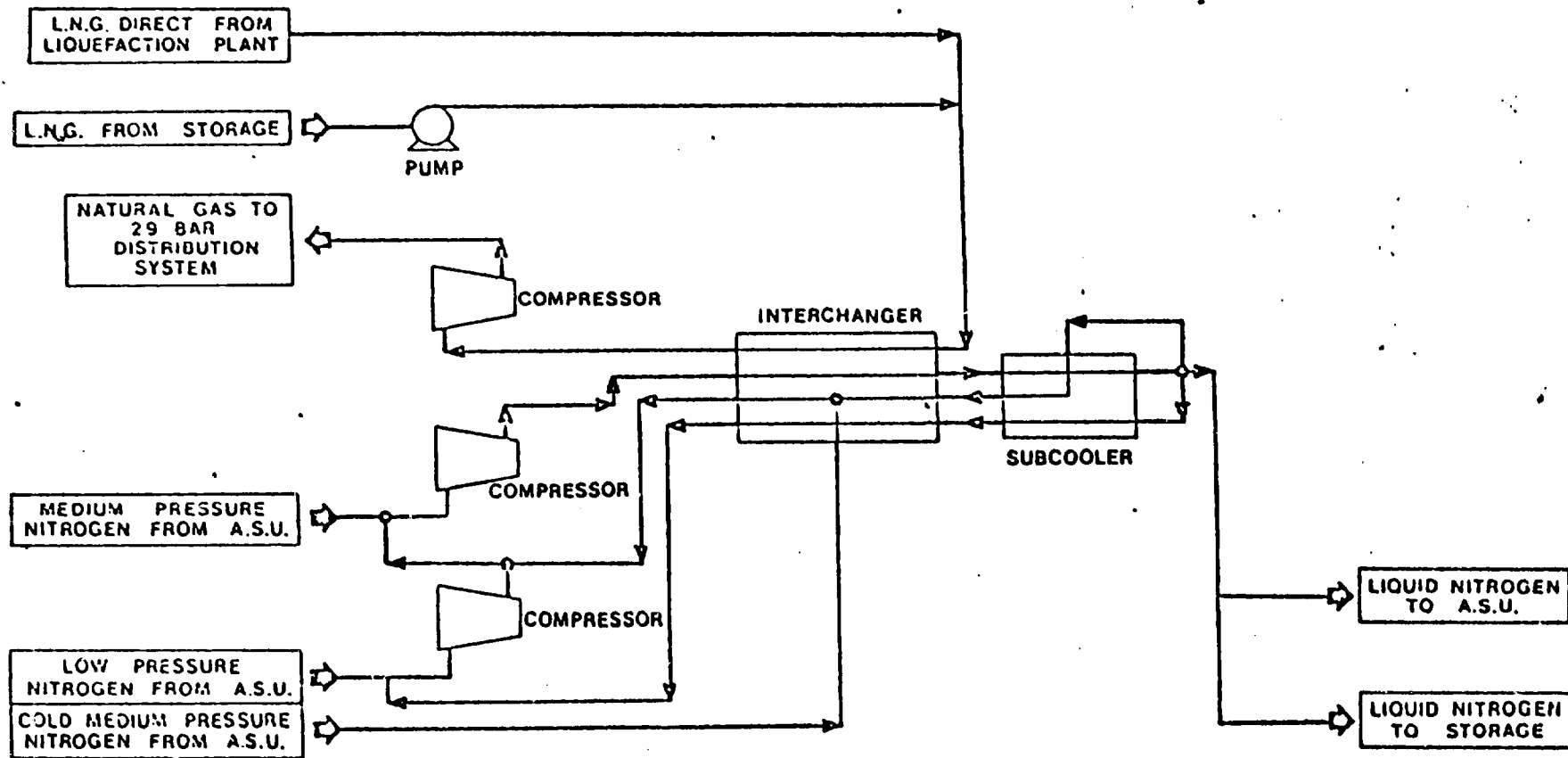

FIGURE 4: FLOWSHEET OF LIQIFIED NATURAL GAS/LIQUID NITROGEN INTERCHANGER SYSTEM

AUSTRALIA/UNIDO WORKSHOP:

WASTE HEAT RECOVERY IN INDUSTRIAL PROCESSES
28th FEBRUARY — 11th MARCH 1983 MELBOURNE

ENERGY CONSERVATION IN INDUSTRY

Mr C.W. Peterson
Corporate Energy Manager
ICI Australia Operations Pty Ltd

The need for energy conservation in a world of shrinking reserves and higher prices is not open to debate, and in industry wasteful use of energy is not only in denial of the national interest, but it is unsound business practice leading to higher costs and lack of competitiveness. The practice of energy conservation gives immediate gains from the most basic applications, through to the exercise of the latest technology, and I would like to relate what we have done as we have followed this pathway.

Energy conservation in a highly technical industry like the chemical industry has always been practised in the interest of economy, particularly where energy is a significant raw material, for example electricity for electrolysis in the manufacture of chlorine or as naphtha/LPG, as a feed-stock for ethylene, propylene etc. Of course energy is used in many forms other than in these important raw materials and in 1978 it was seen that there was a need to obtain a clear understanding of this complex picture. Accordingly a corporate energy survey was undertaken to determine the usage of all energy in all factories and company establishments with the prime purpose of suggesting a strategy for energy conservation in the future. A corporate energy survey in a company of our size would seem a daunting task, but was carried out by two people in about two months with warm support from all levels of management in all centres.

The survey revealed that the energy cost excluding petroleum fractions as feedstocks was 5% of the sales value of manufactured products and 10% of the added value. It was recommended and agreed that a corporate energy manager be appointed in an advisory capacity and that energy coordinators be appointed in each factory. A corporate target of 5% energy reduction in the first year was accepted. It was recognised that support from senior management was essential for a successful energy conservation programme and an increase in awareness must be generated at all levels. The duties of the corporate energy manager included the preparation of energy conservation programmes, monitoring performance, publicity, and most importantly, the introduction of new technology.

It was realised that in establishing an energy conservation programme there was a need to set the units of energy usage; the type and frequency of energy audits; capital funds available on what terms to implement energy saving proposals; and a publicity programme coupled with the need to change emphasis to sustain effective interest. We invented a character called Ernie-G-Waste and his cheery face gave encouragement in our programme during the early stages of the campaign.

84.01.04
AD.85.0

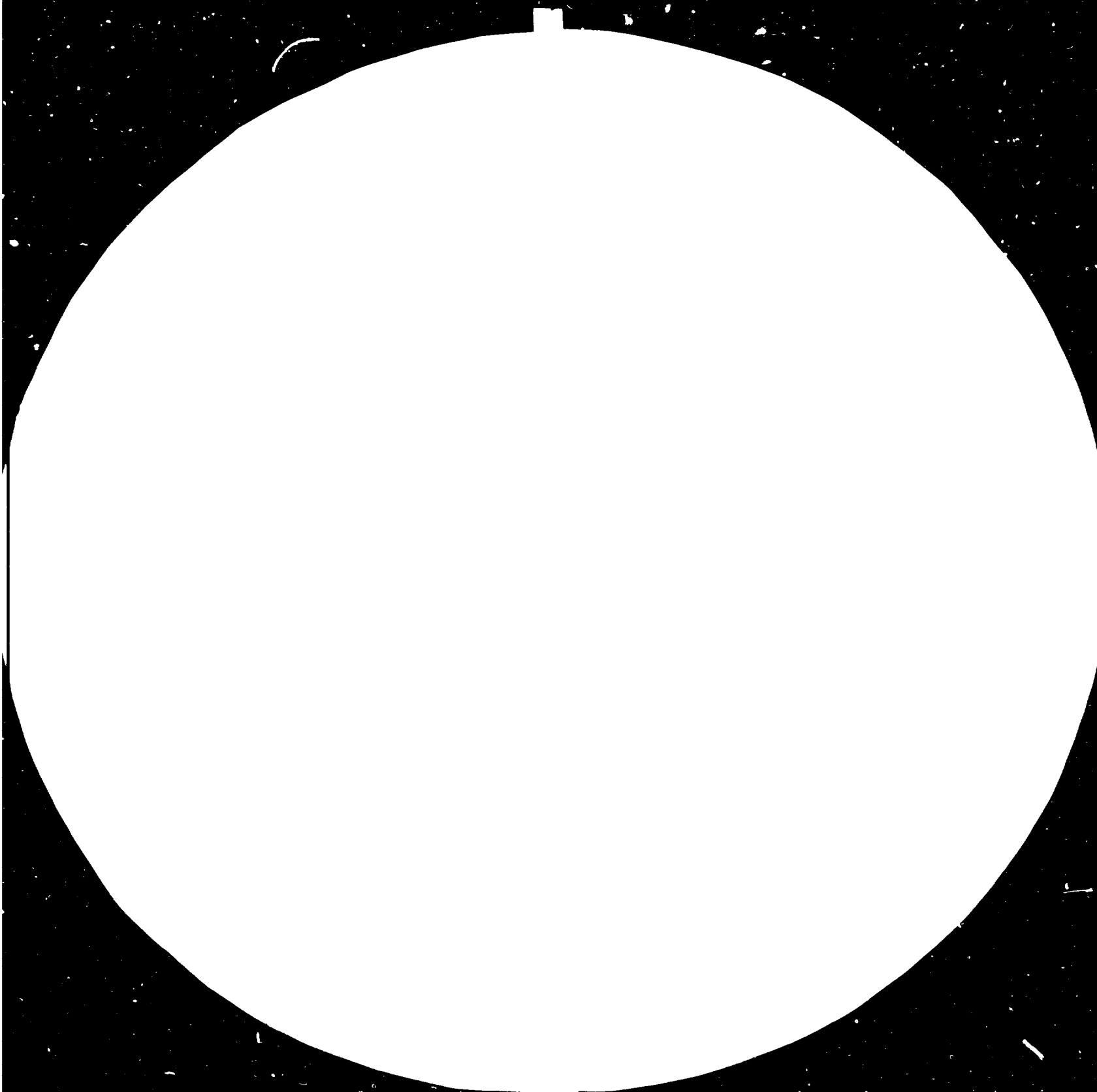



MP Resolution Test Chart, 1977, © GARY
MILNER, INC. 10000 W. 10TH AVE. DENVER, CO. 80231

The energy conservation programme is now prepared annually, based on budget and target values for energy usage provided by the factories for the various energy consuming centres. The energy efficiency in GJ per unit of production is a critical figure and is monitored monthly, together with the energy consumption and the trend against expected performance. The data is entered into a computer data base at the factories, analysed centrally and the results distributed back to the factories and to senior management. The programme also contains details of energy saving projects proposed by the factories and progress is reviewed in the formal half yearly report. Recently, a brief quarterly review on progress towards the cost target has been prepared for senior management. The use of the data base has removed the clerical tedium and allowed more time to be spent applying technology. The development of this organisation supported our progress to what we believe to be four overlapping stages of any energy conservation programme.

In the first phase of an energy conservation programme obvious waste would be eliminated using established technology. Improved housekeeping, for example, better maintenance of steam mains and traps, is an essential component of this study, which should also include examination of insulation, arresting compressed air leaks, and the correction of suboptimal process controls and accounting procedures to highlight costs and perhaps alter internal emphasis.

In the second phase, without moving to new technology, there may be conversion from one energy form to another, sometimes encouraged by the Government in the interests of conservation of particular fossil fuels. In this country encouragement was given to industry to change from fuel oil to coal, or in some cases to natural gas, and we would see a further application in the use of waste heat in low temperature applications. There may be greater scope for solar energy for low temperature water heating.

The third phase is the use of new technology. This will allow unexpected gains but requires technical sophistication not only by those who introduce the new technology, but by those who must apply it. Encouragement is required by the promoter, to develop an attitude of acceptance by the user. In this country support for worthy projects may be obtained from the Government, and we have been fortunate in our work to gain this support in a number of cases. It is common knowledge that there is a reluctance to use new technology, and for this reason I believe more attention should be given to the training of users of new technology, to enable them to assess the proposals of a scientist expert in his field.

The technologies we have embraced include microcomputer/microprocessor systems for better monitoring and control. In this connection we have devised a system of monitoring the maximum electricity demand at our Botany complex which allows operators sufficient time to take corrective action to avoid exceeding the agreed maximum and attracting penalty charges.

Perhaps the most exciting and advanced development at Botany has been what we call the Site Planning Aid. This is a computer package which has been programmed firstly on the basis of all storage and production constraints

on the site, and secondly to provide information on the manner of operation for the optimum use of energy. The site production programmes can be altered by use of a light pen on a colour VDU screen where daily, weekly, and six-weekly basic programmes can be displayed. The use of the light pen can change the programme according to the demands of the market place, and when the best production and storage programme has been obtained, the energy programmes can be accessed. The use once again of the light pen in respect of the energy programme can choose an energy configuration for the site which, coupled with the production programme, will provide the minimum cost operation for the conditions applying on that day in relation to market requirements. The final programme evolved should allow operation of the whole site in the most economic manner for the production and storage of materials and the usage of all forms of energy.

We have found particular use for mathematical modelling to predict energy requirements and we have used optimisation methods to improve efficiency. It is in this area that we have used data reconciliation studies to identify "losses" in energy reticulation circuits and to establish the accuracy of metering equipment. In most recent times we have used non-linear programming, a relatively new technique as opposed to linear programming, to prepare cost analyses hitherto not possible, but most particularly to programme the operation of the Steam and Power Plant at the Botany complex. This programme which will be interactive with the operator, will minimize fuel usage and purchased electricity costs, while meeting process, steam and water requirements and equipment constraints. In future we hope to couple this programme into the Site Planning Aid mentioned above.

Another technique, about which my colleague Mr Davies will speak in greater detail, is what we have termed the second law of thermodynamics analysis, or Linnhoff technology after Professor Linnhoff, formerly of ICI UK who brought this technology to the attention of the engineering world a few years ago. We have trained 24 of our company engineers in this field, and a year ago conducted a two-week course with the Universities of Sydney and New South Wales under the chairmanship of Professor Linnhoff. We see great opportunities for this technique in Australia, not only in the design of new plant but in the improvement of existing plants. It is particularly useful in that sophisticated computer methods are not required, and it provides an understanding of the limitations of the process and allows the design of the more ideal, in the thermodynamic sense.

We have also introduced infra-red imaging to identify heat losses, and insulator weakness, for example, and we will expand this technique in the future. Other interests include more recent computer programmes being developed overseas which we hope to use in our energy conservation programme.

These new technologies will reduce the energy usage in current methods of operation, but open the question as to whether the process can be operated in a different fashion to use less energy. This is particularly important in this recession when the base energy load assumes a greater importance at lower production rates. We have used the term "low energy mode of operation" and recognise that it requires a considerable technical

effort by staff, foremen and operators to devise and use a new operating technique replacing that used for a number of years. We recognise the need to maintain safety and quality, but really must question all aspects of our operating techniques. For example, must the reflux of that distillation column be at that rate for so long, or is the crystallisation temperature profile ideal, or do we need to pump this fluid at such a volume for so long, and must that refrigeration system be run so cold? Finally, in the field of new technology we look forward in the longer term to the use of solar power as a heat source, process intensification to reduce the physical size of plant, new materials, and even more precise control and detection mechanisms.

The energy conservation programme was put into operation about four years ago. Since then, with the steps outlined above, we have created an awareness of the need for energy conservation and introduced significant new technology. Our efforts have seen reduced energy consumption over the past three years of 5.8%, 1.6% and 3.8%.

The magnitude and diversity of energy usage in a large enterprise, and the availability of technical expertise does not mean that opportunities are not available to smaller businesses. It simply means that the starting point is different and the percentage gain may be less, but the value to the enterprise is just as real. The introduction of a programme would require the primary audit, elimination of waste and low cost correction of poor operation. Staff must be encouraged to participate, and the lead given from senior management by insisting on targets being set by line managers, and by supporting the energy conservation programme during its currency. Publicity should be employed as applicable at all levels, particularly in the early stages. Consultants can be used if technical expertise is not available, but company staff should be trained and particularly taught the use of the simpler thermodynamic analytical methods.

Energy conservation is essentially the control of a resource at the lowest consumption level and will be ineffectual unless one can measure achievement. Adequate metering equipment is essential and as Lord Kelvin said many years ago "if you can't measure it, you can't control it". Energy conservation in industry is measurement, reduction and control, using all available means at our disposal.

AUSTRALIA/UNIDO WORKSHOP:

WASTE HEAT RECOVERY IN INDUSTRIAL PROCESSES
28th FEBRUARY — 11th MARCH 1983 MELBOURNE

APPLICATION OF THERMODYNAMIC
PRINCIPLES TO OPTIMISE ENERGY CONSERVATION
DESIGN

Mr K.W. Davies
Energy Conservation Co-ordinator
Petroleum Refineries Australia

SUMMARY

Increasing fuel costs are constantly demanding better energy conservation programs. This is possible through an increased understanding of the fundamental ways in which fuel is used to provide the means of powering refinery processes.

The objective of this paper is to show that the key to successful energy conservation lies with the preparation of balances and studies associated with following the quantity of useful energy through the processes. Traditional approaches have followed the amount of total energy and this tends to conceal the location of the greatest opportunities for improvement.

Calculation methods and some examples are also provided, together with references for further study.

INTRODUCTION

The problem of "energy conservation" is actually misnamed. Energy is conserved by nature, as refinery engineers regularly demonstrate when they perform routine energy and material balances around refinery units.

To be successful with "energy conservation", it is necessary to understand the fundamental changes which take place in an oil refinery. In the creation of ordered products from crude oil we introduce "order" into a random system and consequently reduce the entropy of crude turned to products. This is accomplished through an increase in the entropy of the fuels consumed. The minimisation of fuel usage is therefore accomplished through systematic entropy conservation. What is needed in refineries is an "entropy conservation" program.

The task of the energy conservation engineer, therefore, is to determine the real energy requirements and match the quality of the energy source and the quality of the requirement so that the needs of the process are just satisfied and no more.

The aim of this paper is to show that entropy conservation is a practical tool which refinery engineers can use to systematically reduce refinery fuel consumption. Exergy (or availability) is defined as the means through which refinery processes are analysed and opportunities for fuel conservation identified.

Through the use of "Process" a Simulation Science computer program, the source of losses and projects for their reduction are readily identified.

IDENTIFICATION OF THE REAL THERMAL LOSSES IN

AN OIL REFINERY

The first phase of the work of the energy conservation engineer is to discover the real losses in the refinery.

Traditional methods of the measurement of efficiency are of little help in coming to grips with this requirement. An understanding of this problem is facilitated by consideration of the following two examples which are both 80% efficient based on the traditional methods of evaluation.

TWO DIFFERENT BOILER EFFICIENCIES

BOILER NO. 1 PRODUCES SUPERHEATED HIGH PRESSURE STEAM

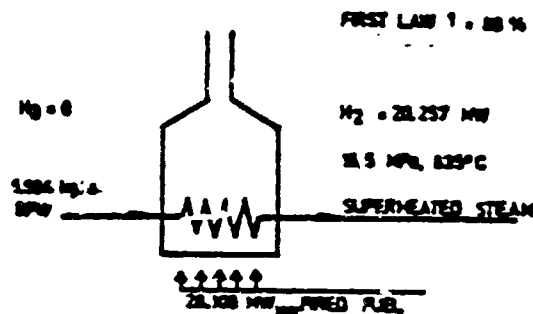

BOILER NO. 2 PRODUCES HOT WATER

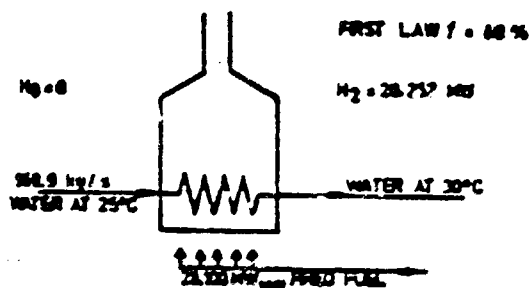

Although each is 80% efficient by the conventional criteria, there has to be a difference in real efficiency. One of the two is producing highly useable material while the other is producing effectively practically nothing. The scheme producing warm water could easily accomplish the same result using much less fuel (or less than half as much) by a more efficient method, for example, by using a heat pump.

The same type of problem is seen in the analysis of steam cycles using condensing turbines. A large loss is wrongly attributed to the condenser, whereas in reality the condenser loss is extremely small, and the real losses are elsewhere in the process.

There is a requirement to quantify the losses in inefficient processes and identify methods for their recovery.

EXERGY - A METHOD TO QUANTIFY USEFUL ENERGY

To obtain a practical method to analyse thermal systems it is necessary to be able to calculate the amount of energy in our section which is available for use and identify where the usefulness of the energy is degraded. To accomplish this, we combine the concepts of energy quantity (enthalpy) and energy quality (entropy).

In order to appreciate how they can be combined and utilised, consider the ambient (equilibrium) condition in which our processes are situated and in which the crude oil comes in and into which the products leave. It is necessary to expend energy to deviate to temperatures or pressures either higher or lower than ambient and throughout the refinery there are everywhere driving forces trying to return the system to environmental temperature and pressure.

Define T_0 and P_0 as the reference (absolute) temperature and pressure. If H is enthalpy and S is entropy, define exergy :-

$$E = (H - H_0) - T_0 (S - S_0)$$

where the subscripts 0 denote the property values at the specified reference conditions. (A more complete form appears in Appendix A).

Any deviation from the reference conditions requires the input of work to achieve it; or alternatively work could be obtained in the return of the fluid to the reference state. The minimum work to achieve the change is equal to the value of the exergy E at that point and is also the maximum amount of work which could be generated in the return to equilibrium.

Conservation of Exergy

Conservation of Exergy does not exist in the same way as for mass or energy. But the losses can be accounted for and all losses have to be paid for in fuel and consequently in dollars:

Conservation of Mass

$$\sum M_{in} = \sum M_{out}$$

Conservation of Energy

$$\sum \text{Energy}_{in} = \sum \text{Energy}_{out}$$

Balance of Exergy

$$\sum E_{in} = \sum E_{out} + E_{loss}$$

For an entire refinery E_{loss} is the total refinery fuel an expensive commodity which well justifies the use of more complex methods for its systematic reduction.

Efficiency - Real Efficiency

$$\eta_{2ndL} = \frac{E_{out}}{E_{in}}$$

Processes such as the one shown previously in which the boiler is generating warm water - reveal their low true efficiencies by this method:

TWO DIFFERENT BOILER EFFICIENCIES

BOILER NO. 1. PRODUCE SUPERHEATED HIGH PRESSURE STEAM

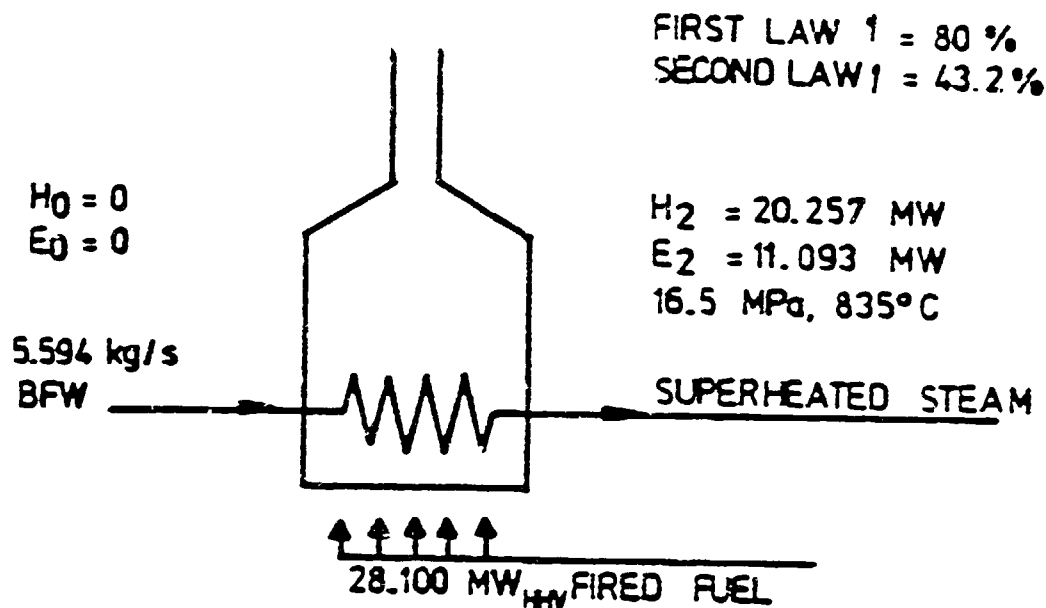

BOILER NO. 2. PRODUCE HOT WATER.

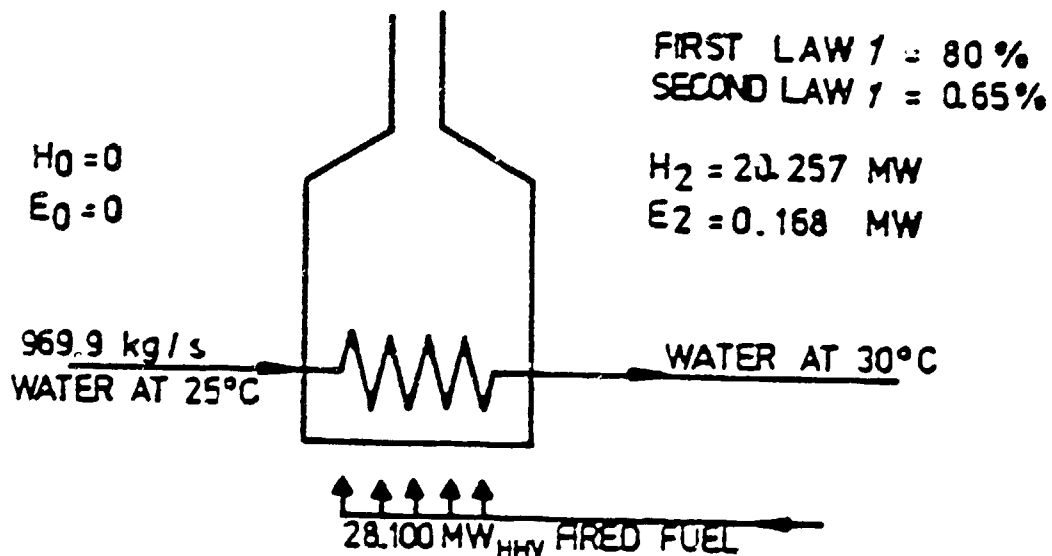

- THIS IS AN EXTREME CASE, BUT IT MEANS THAT THERE ARE MUCH BETTER WAYS TO PRODUCE LOW TEMPERATURE HEAT THAN USING FURNACES.

This type of analysis directs the energy conservation engineer to look for a better method to satisfy the energy (exergy) requirement. An example showing what this amounts to appears in Appendix B. The application shown is a domestic example which is more easily understood. There are many analogous applications in the refinery.

Exergy Losses

The really large, as well as the easily recovered, losses are not readily identified; or at least they cannot be quantified by the traditional methods. They are caused by "irreversibilities" and some amount of them is necessary to drive the process. The success of our so called energy conservation programs are a measure of our success in reducing them and in distributing them more evenly. Some of them are listed below.

<u>Driving Force/Loss</u>	<u>Example</u>
Combustion by chemical reaction	Fired heaters and boilers
Heat transfer by temperature driving force	Difference between flame temperature and process fluid in furnaces Temperature driving force in heat exchangers
Mechanical friction caused by motion	Pumps, compressors, turbines
Electrical resistance losses resulting from potential difference	Electric conduits
Throttling by pressure driving force	Control valves
Mixing by concentration driving force	Blending

There are many others.

Usually, the source of the major losses is not obvious. An exergy analysis identifies the problem areas.

Identifying the Major Losses - The Exergy Analysis - Hand Calculations

To explain the exergy method, an analysis is performed on the following (relatively straight forward) example.

Details of the actual calculations appear in Appendix C "Steam Power Plant Exergy Balances."

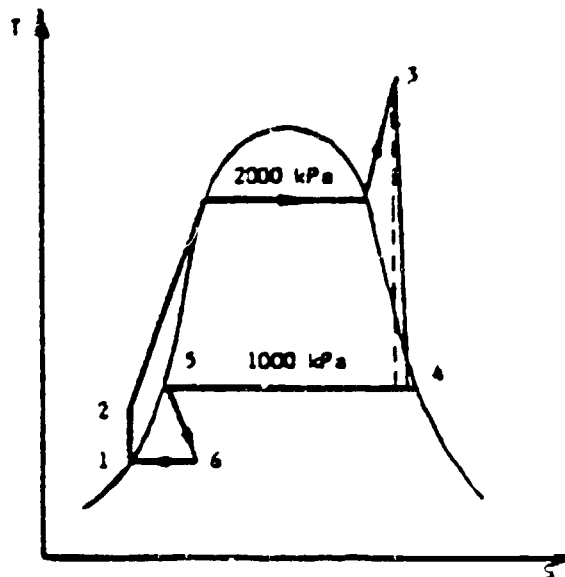
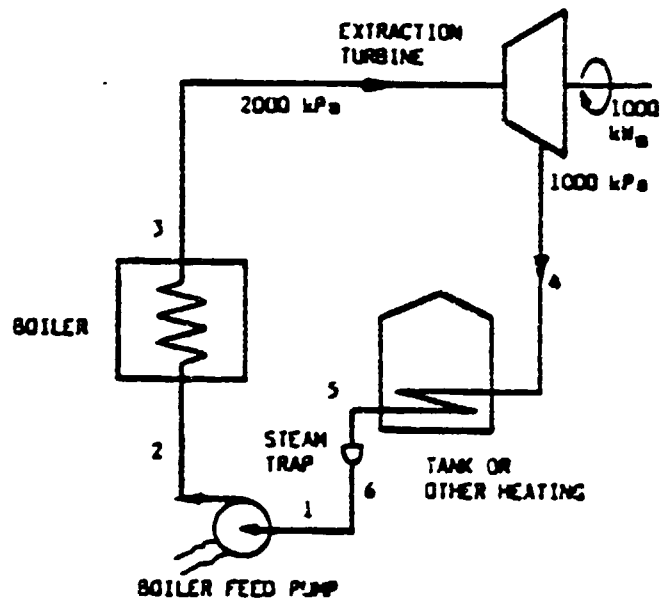

From the balances the following diagrams summarise the results:

BOILER AND STEAM ENERGY BALANCE

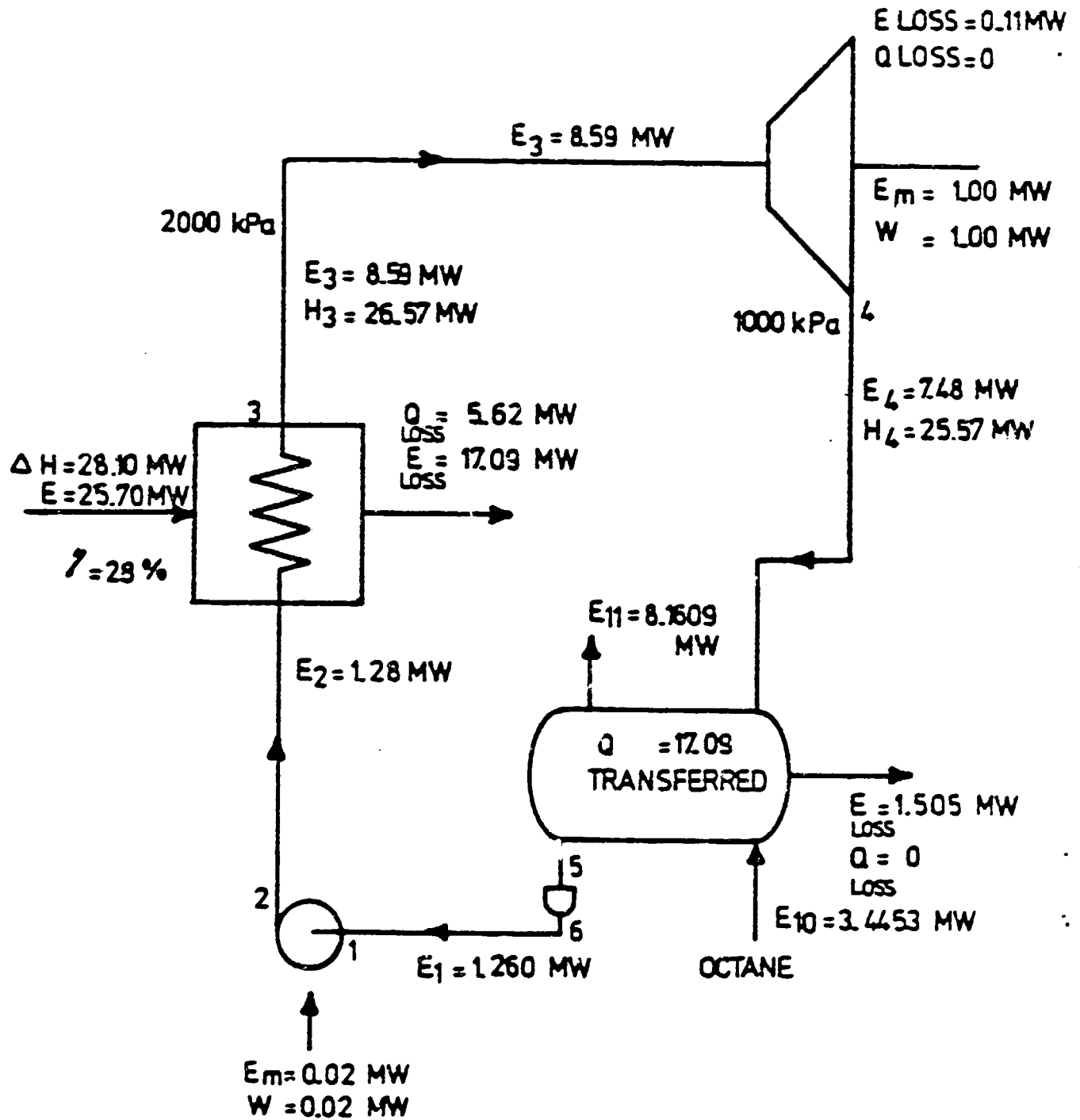

- EXERGY DIFFERENTIATES BETWEEN HIGH TEMPERATURE AND LOW TEMPERATURE ENERGY.

The results of the traditional first law analysis and the energy (second law) analysis are shown below:

FIRST LAW ANALYSIS - ENERGY USAGE

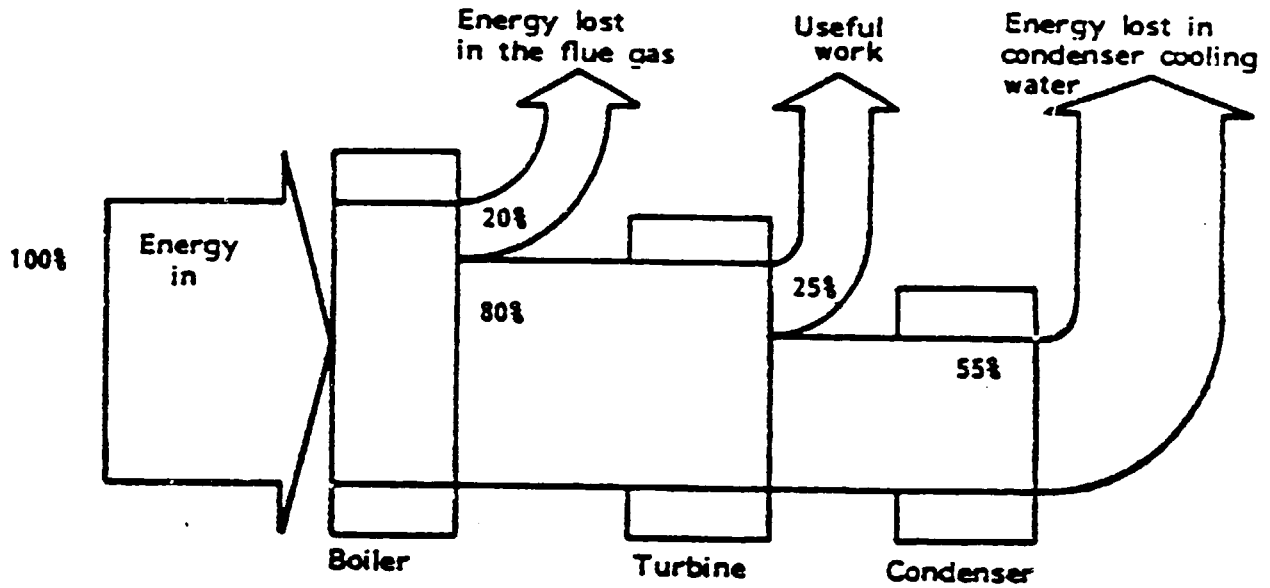

SECOND LAW ANALYSIS - EXERGY USAGE

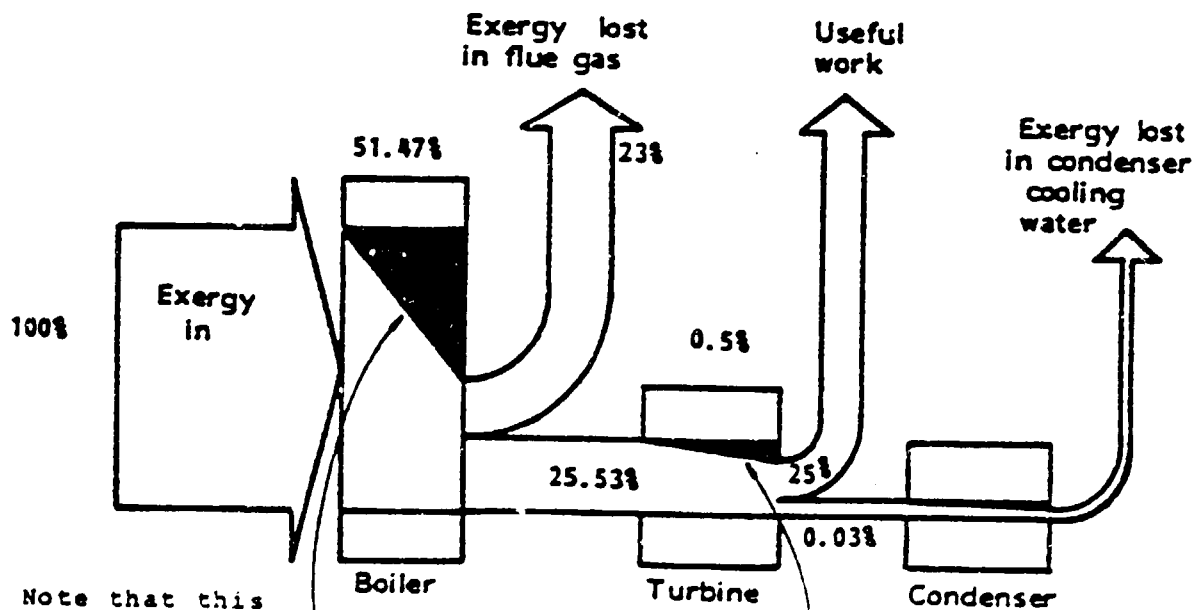

Note that this analysis is for a fully condensing turbine

Losses due to "irreversibility"

The results demonstrate that, contrary to common belief, the biggest loss is in the furnace which is really only 25% efficient, and that the losses through the use of efficient turbines are almost negligible as are the losses to the cooling water. The losses in the furnace amount to 75% and are of three types:

a. The irreversible nature of combustion	-	9%
b. Loss to the flue gas	-	23%
c. Large flame to process temperature driving force	-	43%
		75%

The furnace efficiency is greatly affected by the process conditions of the fluid leaving the furnace. The following example demonstrates how great this effect is for the example of steam/water. The furnace conditions for each amount to an efficiency of 80% based on the first law of thermodynamics and fuel lower heating value (customary basis used in Mobil):

CONDITIONS OF GENERATED STEAM	FIRST LAW EFFICIENCY	SECOND LAW EFFICIENCY
A. 30°C HOT WATER	80,0%	0,65%
B. 400 kPa _A SATURATED, 1436°C	80,0%	23,36%
C. 10 000 kPa _A SUPERHEATED, 484,5°C	80,0%	35,52%
D. 16 500 kPa _A SUPERHEATED, 835°C	80,0%	43,17%

SOME BOILER EFFICIENCIES

The foregoing identifies a major source of loss which applies throughout the refinery and can be greatly reduced as discussed later by:

- a. Eliminating those furnaces which produce relatively low grade heat by means of either:
 - (i) using exhaust steam from turbines.
 - (ii) heat pumping process fluids being condensed.
- b. Restructuring the process.

Exergy Analysis by Computer Simulation

An Exergy Study on the Altona No. 2 Crude Unit

The Simulation Science, "Process" computer program permits calculations to be performed to determine exergy losses in all refinery unit operations. The program is similar in scope to Quikbal but it generates thermodynamically consistent property data, including entropy, which allow balances to be performed throughout the refinery to determine the source of losses and devise a solution for their reduction.

Appendix D shows an exergy balance around the Altona Crude Unit 2. Note that the outlet stream exergies are shown prior to air or water cooling.

As previously the exergy loss analysis is the key to the location of potential energy conservation projects. The loss Analysis for the Altona Crude Unit 2 appears below:

EXERGY INPUTS

SOURCE	EXERGY MAGNITUDE MM
FIRED FUEL	62,78
STRIPPING STEAM	1,95
IMPORT FROM TCC	7,26
ELECTRICITY, ESTIN; ETC.	2,00
TOTAL	73,9

EXERGY USAGE AND LOSSES

SOURCE	EXERGY MAGNITUDE MM
THEORETICAL REQUIREMENT FOR SEPARATION	1,6
EXPORT TO TCC	8,4
EXPORT TO CRUDE 3	
LOSSES: FURNACE - IRREVERSIBILITY OF COMBUSTION	
- LOSS DUE TO TEMP. DRIVING FORCE	
DISTILLATION - MAIN TOWER	5,7
- STRIPPERS	0,4
HEAT INTERCHANGERS - IRREVERSIBILITIES	7,0
OVERHEAD CONDENSER	6,3
LOSSES TO COOLING WATER	0,7
OTHER LOSSES	
TOTAL: (adjusted)	73,9

Nett exergy input to Crude 2 = 63,7 MM, yielding an efficiency of 2, 1 with which the process turns crude oil into ordered products using fuel.

ALTONA CRUDE UNIT 2 EXERGY BALANCE

As previously, the greatest need for efficiency improvement rests with the furnace, which because heat of only a moderate temperature is recovered from it, has an efficiency of only 30%. To effect an improvement here it would be necessary not only to reduce the excess air and the stack gas exit temperature but also to recover higher temperature heat ahead of the heating of the oil. The function served would be to provide a working fluid for mechanical/electrical power generation and then use the exit fluid for heating where the exergy requirement of the heating is small. These schemes have a big effect but are difficult to arrange.

Another area well worthy of attention is the fairly large loss due to temperature driving forces in heat exchanger. Also, some exchangers serve no function at present, for example E13. Refer to the complete list of heat interchanger losses in Appendix E. There is also plenty of scope to reduce air/water cooling. Possibly, the overhead condenser could be heat pumped to place its duty at a convenient point in the heat exchanger train, alternatively a tip top pumparound might solve some of the problem.

The analysis of the solutions to this crude unit design problem based on exergy is still in progress.

Other Sources of Losses

Although furnaces represent the greatest losses in work availability and hence the greatest real losses by far, other pieces of equipment also incur losses and offer easy savings.

The traditional refinery steam system with inefficient condensing turbines or turbines venting to atmosphere is an area worthy of attention. Although good quality back pressure turbines can easily reach 98% efficiency, many typical (large size) turbines operating in the saturation region run at efficiencies near 50% and smaller turbines are often only 10% efficient.

TURBINE	SECOND LAW EFFICIENCY
ALTONA PTR 3 - BACKPRESSURE SECTION	98%
ALTONA PTR 3 - CONDENSING SECTION	39%
ADELAIDE PTR	53%
ALTONA PTR 1	52%
ALTONA CRUDE 2 - REDUCED CRUDE PUMP	15%
ALTONA UTILITIES - SERVICE WATER PUMP	10%

DESIGN EFFICIENCIES OF SOME PTR STEAM TURBINES

REDUCING THE LOSSES - THE EXERGY AUDIT

The commencement of a systematic program for the reduction of exergy and therefore energy usage in a refinery begins with an audit of the major sources of losses.

The methods by which this is most readily accomplished are well described in Reference number 1, although the methods to use for tackling complex hand calculations are not covered in this book. Most of the calculations in a refinery are difficult, involving entropy of mixing and difficulty in obtaining adequate property data for entropies. Some simplifications are discussed in Reference 2; also References 18 and 19 provide thermodynamically consistent enthalpy and entropy data for many light hydrocarbons. Refineries with well developed Quikbal models would find it easy to perform simulations on the Simulation Sciences computer program (available through General Electric Information Services). This is discussed in Reference 3.

A general discussion of sources of refinery exergy losses and the general type solution needed to each is given in Appendix F.

Many of the losses in common processes are quantified using the methods of Appendix H.

Although the concept is difficult to grasp, the losses are tangible and expensive. Each loss can be assigned a dollar loss value.

FINDING LOW EXERGY (LOW ENERGY)/ SOLUTIONS TO LOW EXERGY
APPLICATIONS

With the assistance of the Exergy Audit, applications having a low exergy requirement become apparent. The domestic gas heat pump of Appendix B gives clues to this.

Frequently, in a refinery they are supported by fired heaters and could be substituted by heat pumps or back pressure turbine exhaust steam.

The diagram below shows some novel approaches to distillation, from Reference 10. A more detailed flowsheet appears in Appendix G.

Three different methods of energy recovery compared with conventional distillation.

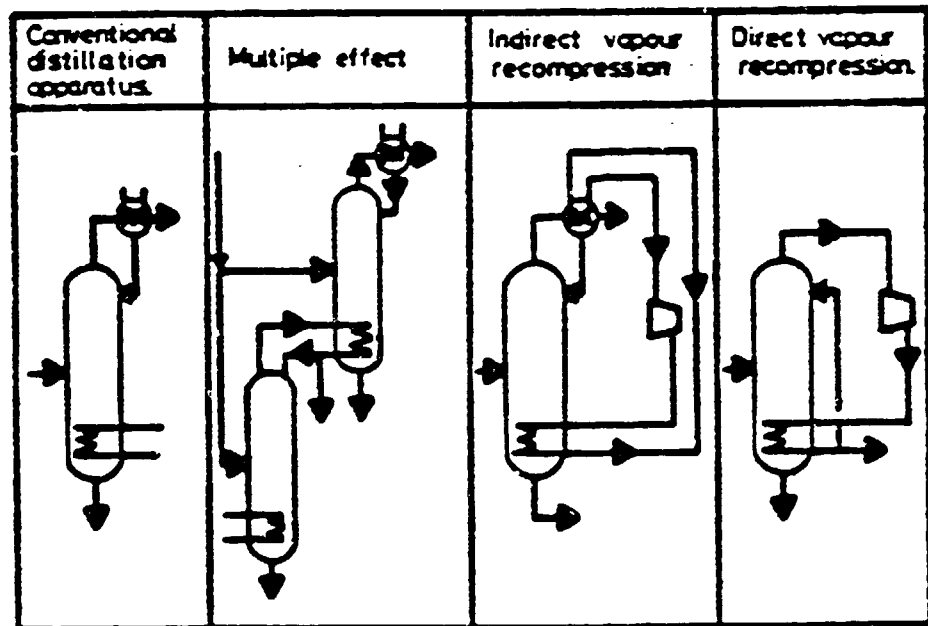

Other techniques such as absorption refrigeration and low temperature Rankin cycles are related subjects, both intended to make use of the resources available.

DISTINGUISHING BETWEEN AVOIDABLE AND INEVITABLE LOSSES

This is the most difficult part of the analysis, but also a very important part.

Some of the irreversibilities incurring high refinery fuel consumption can easily be changed with better design. Others are as elusive as the achievement of carnot cycle efficiency for practical refinery processes. Applications such as the recovery of heat reversibly from a chemical reaction at the temperature at which the reaction takes place are frequently not achievable and need to be recognised as unattainable, and quantified. This is the task of the experienced energy conservation engineer. Some guidance is effected by Reference No.2.

BALANCING HEAT AND WORK REQUIREMENTS IN THE REFINERY

This is an essential part of the energy conservation program. Successful accomplishment of this task necessitates a thorough knowledge of the mechanical work requirements in the refinery and all the heating requirements and the temperature associated with each one.

A design is then compiled which looks at candidates for:

- a. Heat pumps (driven by high pressure steam)
- b. Heating using back pressure steam.

There are often applications which could use either, so an excess of either low pressure steam (or low level heat) or an excess of high pressure/medium pressure steam can be "mopped up" profitably. A further advantage of the heat pumped distillation column is that it frees the process from the temperatures, and hence the pressures associated with the cooling water condenser and allows a design which requires less energy anyway.

GENERATION OF ELECTRICITY IN THE REFINERY

Cogeneration for the simultaneous production of electricity and process heat is an essential part of this task of properly balancing heat and work requirements in the refinery. There are many possible options and there are definite advantages for some schemes.

To evaluate the relative merits of common alternatives the following three schemes were evaluated:

- a. Scheme 1: Gas turbine for electricity generation and a waste heat boiler for the production of process heat or steam.

- b. Scheme 2: Conventional boiler and turbine-generation system with the turbine exhaust providing steam for low temperature (180°C) process heat.
- c. Scheme 3: Application of a gas turbine to provide electricity generation and then using the gas turbine exhaust as the "air" to a process furnace, supplying sufficient fuel to achieve an excess air of 10%.

The schemes are shown schematically in Appendix I. To simplify the evaluation, calculations were performed using moderately high temperature steam generation in lieu of process heat in furnaces. However, the conclusions are equally valid for a comparable grade of process heat.

The results are summarised below:

CRITERION		UNIT OF MEAS.	SCHEME 1 GAS TURB & WASTE HEAT ECONOMISER	SCHEME 2 CONVENTIONAL BOILER	SCHEME 3 GAS TURBINE & EXHAUST GAS FIRED WITH SUPPLEMENT FUEL
EFFICIENCY	First Law "Effic."	%	73,5 %	86,1 %	86,2 %
	Second Law "Effic."	%	45,6 %	39,8 %	44,1 %
OUTPUTS	Electrical Output	MW	10,45	5,01	10,45
	Process Heat	MW	22,62	37,80	121,47
	Process Heat Temp.	°C	407°	180°	407°
FIRING	% Excess Air	%	274 %	10 %	10 %
	Stack Temp	°C	140	140	140

OPTIONS FOR COGENERATION

The gas turbine has the key advantage that it recovers mechanical work from the high temperature combustion of the fuel. Including the exergy value of the exhaust, the gas turbine/generator alone (Thomassen G3142J) has a second law efficiency of 53% which is a lot better than that achieved by other fired equipment.

The problem of the gas turbine is its high excess air, in this case 274% which prevents a high first law efficiency. This results in the loss of a large quantity of moderately low grade energy, ie with low exergy, and in this case difficult to utilise.

A practical solution to this problem is possible by using the high oxygen turbine exhaust as the air input to a refinery furnace which produces high temperature heat such as a reformer or cracking unit furnace. The scheme would require the generation of steam and additional boiler feed water heat or equivalent low temperature process heat to achieve a stack temperature of 140°C without a temperature cross in the convection section.

Good utilisation of the combustion enthalpy is achieved with a high second law efficiency. The high second law efficiency is reflected in the simultaneous production of electricity and high temperature process heat with a low total fuel requirement. Its advantage over the conventional boiler plant is the simultaneous production of high temperature process heat which in the conventional boiler (Scheme 2) would have to have been provided using another furnace which still would have the usual problems of inability to recover sufficiently high temperature energy (high exergy material).

Note that the implementation of the recommended Scheme 3 would require a large furnace (120 MW in the example) for the efficient utilisation of the exhaust of 10 MW of electricity generation, implying the use of the combined reforming and catalytic cracking furnaces in many refineries.

It is also relevant to appreciate that these furnaces may then require much of the available boiler feed water heating and steam generation to reduce the stack temperature to 140°C, with air preheat alone used to reduce the stack temperatures of the other furnaces.

The scheme is economically attractive as outlined in Reference 25.

NEW TECHNIQUES FOR HEAT EXCHANGER

NETWORK DESIGN

A new method is available for this essential step in re-engineering the refinery for low energy. The method was devised by Linhoff and others working at the ICI Corporate Laboratory in the United Kingdom. It is described in reference 31.

LIST OF APPENDICES

- A. The Complete Exergy Equation
- B. The Gas Heat Pump - Domestic
- C. Steam Power Plant Exergy Balance
- D. Altona Crude Unit 2 Exergy Balance
- E. Exergy Losses in Altona Crude 2 Heat Exchangers
- F. Exergy Losses in Refineries - Causes and Cures
- G. The Heat Pumped Distillation Column
- H. Exergy Losses of Common Processes
- I. Possibilities for In Plant Electric Generation

LIST OF REFERENCES

1. JOHN E. AHERN "The Exergy Method of Energy Systems Analysis"
Wiley-Interscience 1980.
2. D.W. TOWNSEND "Second Law Analysis in Practice" Chemical
Engineer October 1980 Pages 828-633
3. C.K. VENKATESH, R. WAYNE COLBERT, Y.L. WANG "Exergy Analysis
Using a Process Simulation Program"
Simulation Sciences XX National Conference of Mexican
Institute of Chemical Engineer 15-17 October 1980
Acalpulco Mexico
4. F.G. SHINSKEY "Prospects for Energy Conservation in the
Process Industries" Foxboro Company.
5. VICTOR KAISER, GERALD HECK AND JOELLE MESTRALLET
"Optimise Demethaniser Pressure for Maximum Ethylene
Recovery" Hydrocarbon Processing June 1979
Pages 115-121.
6. RICHARD A. GAGGIOLI, PETER J. PETIT "We Second Law, First"
Chemtech. August 1977 Pages 496-506.
7. R.W. HAYWOOD "A Critical Review of the Theorems of Thermodynamic
Availability with Concise Formulations" Journal of Mechanical
Engineering Science Vol. 16 No. 3, 1974 Pages 160-173.
8. MARCELLO PICCIOTTI "Optimise C₂H₄ Plant Refrigeration"
Hydrocarbon Processing May 1979 Pages 157-166.
9. VICTOR KAISER "Energy Optimisation" Chemical Engineering
23 February 1981 Pages 62-72.
10. R. DANZIGER "Distillation Columns with Vapour Recompression"
CEP September 1979.

LIST OF REFERENCES (CONTD)

11. V. KAISER, P. DAUSSY, O. SALHI "What Pressure for C₂ Splitter?" Hydrocarbon Processing January 1977 Pages 123-126.
12. CHEN-HWA CHIU "Evaluate, Separation for LNG Plants" Hydrocarbon Processing September 1978 Pages 266-272.
13. F.G. SHINSKEY "Energy Management Systems for Cogeneration" Foxboro Company.
14. G. GOOSSENS "Principles Govern Energy Recovery" Hydrocarbon Processing August 1978 Pages 133-140.
15. F.G. SHINSKEY "Entropic and Anti-entropic Processes and the Future of Technology" Foxboro Company.
16. F.G. SHINSKEY "Energy Conservation through Control" Academic Press 1978
17. F.G. SHINSKEY "Distillation Control for Productivity and Energy Conservation" McGraw-Hill 1977
18. LAWRENCE N. CANJAR, FRANCIS S. MANNING "Thermodynamic Properties and Reduced Correlations for Gases" Gulf 1967
19. KENNETH E. STARLING "Fluid Thermodynamic Properties for Light Petroleum Systems" Gulf 1973
20. SULZER "Savings in Energy Costs of Up to 80% with Sulzer Rectification Columns" Sulzer Borchur
21. G. SOLIGNAC "Panorama d'Activites de la Division Analyse des Processus en 1979" Rapport HP40/80/312 - Electricite de France Direction des Etudes et Recherches
22. W. MEIER "Sulzer Columns for Rectification and Absorption" Sulzer Technical Review 2/1979

LIST OF REFERENCES (CONTD)

23. "Compte Rendu du 2e Forum Electro-Industrial National - Industries Chimiques" Lyon 6 et 7 Novembre 1980 Comite Francais d'elecirothermie
24. CHEN-HWA CHIE "Exergy Analysis Aids Equipment Design for Cryogenic Processes" Oil and G Journal 18, January 1982 Pages 89-9
25. ROBERT J. GARTSIDE "Cogenerate for Energy Efficiency" Hydrocarbon Processing DEC '81 Pages 125-131
26. B. LINHOFF AND K.J. CARPENTER "Energy Conservation by Exergy Analysis, the Quick and Simple Way" Second World Congress of Chemical Engineering, Montreal Canada 4-9 Oct, 1981.
27. G.P. QUADRI "Use Heat Pump for P-P Splitter" Hydrocarbon Processing March 81 Pages 147 - 151
28. XAVIER HURSTEL, PHILIPPE LEPETIT, VICTOR KAISER "Refrigeration Schemes Serve Olefin Plant Nees" Oil and Gas Journal 7 Sep 1981, Pages 107-123
29. LOTHAR RIEKERT "The Conversion of Energy in Chemical Reactions" Energy Conversion Vol. 15 Pages 81-84
30. LOTHAR RIEKERT "Energieumwandlung in chemischen Verfahren" Ver. Bunsenges Phy. Chem. 84 Pages 964-973 1980
31. BODO LINHOFF AND JOHN A. TURNER "Heat Recovery Networks: New Insights Yiled Big Savings" Chemical Engineering 2 Nov 81 Pages 56-70
32. D.W. TOWNSEND AND B. LINHOFF "Designing Total Energy Systems by Systematic Methods" paper presented at "Total Energy Design in Process Plants" Chem. E./SCI one day conferance, London 29 Apr. 81
33. H.A. DUNFORD AND B. LINHOFF "Energy Savings By Appropriate Integration of Distillation Columns into Overall Processes" Paper 10 "Cost Savings in Distillation" Symposium, Leeds 9-10 July 81
34. B. LINHOFF AND J.A. TURNER "Simple Concepts in Process Synthesis Give Energy Savings and Elegant Designs" Chemical Engineer Dec 80 Pages 742-746

APPENDIX A.THE EXERGY EQUATION

Exergy, or work availability is a state function which is fully specified by a knowledge of the system parameters.

From the system parameters, exergy can be calculated at any point in the system from the following equation:

$$\begin{aligned}
 E = & (u-u_0) + P_0 (v-v_0) + \frac{1}{2}v^2 + g(z-z_0) + (\mu_0 - \mu)N_C + \\
 & \text{internal} \quad \text{pressure} \quad \text{kinetic} \quad \text{potential} \quad \text{chemical potential} \\
 & \text{energy} \quad \text{energy} \quad \text{energy} \quad \text{energy} \quad \text{energy} \\
 & + e_i A_i F_i (3T^4 - T_0^4 - 4T_0 T_3) + \dots \\
 & \text{radiative emission potential} \\
 & \text{energy} \\
 & - T_0 (s-s_0) \\
 & \text{entropy}
 \end{aligned}$$

Usually, all the kinetic and potential energy terms can be neglected, so that the equation simplifies to:

$$E = (h-h_0) - T(s-s_0)$$

HEATING USING GAS

PROVIDE 20 kW OF AIR HEATING

TRADITIONAL METHOD

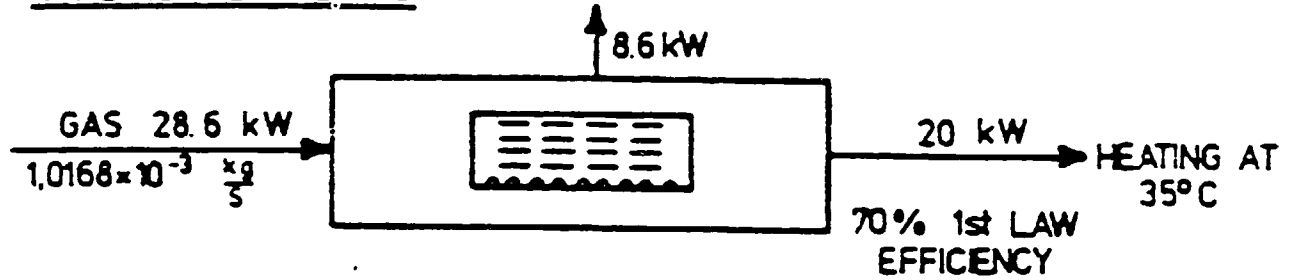

HEAT PUMP METHOD

- USES HALF AS MUCH FUEL FOR THE SAME JOB

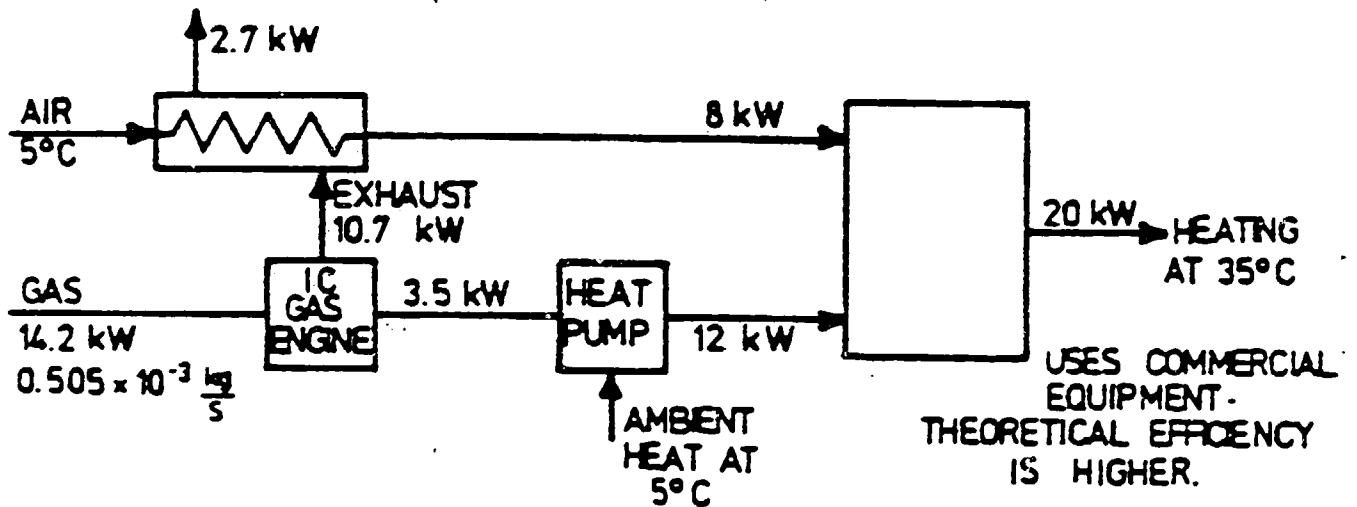

SANKEY DIAGRAM FOR HEAT PUMP SOLUTION

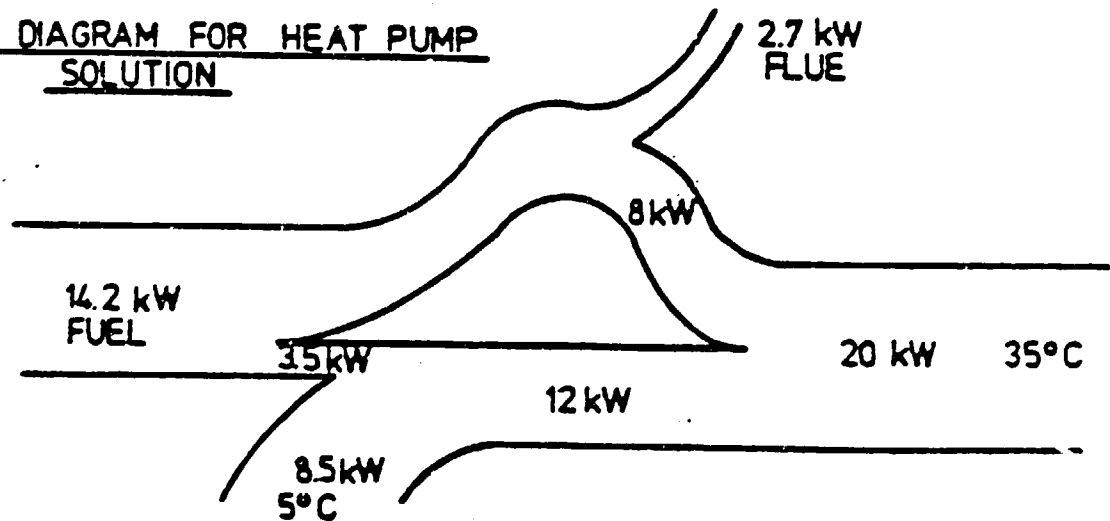

STEAM POWER PLANT ENERGY BALANCESAMPLE HAND CALCULATIONExergy Balance around the Reboiler / Heater

Suppose the reboiler / heater is a heater for normal octane

Corresponding to 1000 kPa saturation

$p_4 = 1000 \text{ kPa}$	$p_5 = 1000 \text{ kPa}$
$t_4 = 179.9 \text{ }^\circ\text{C}$	$t_5 = 179.9 \text{ }^\circ\text{C}$
$h_4 = 2778 \text{ kJ/kg}$	$h_5 = 763$
$s_4 = 6,586 \text{ kJ/kg K}$	$s_5 = 2,138$

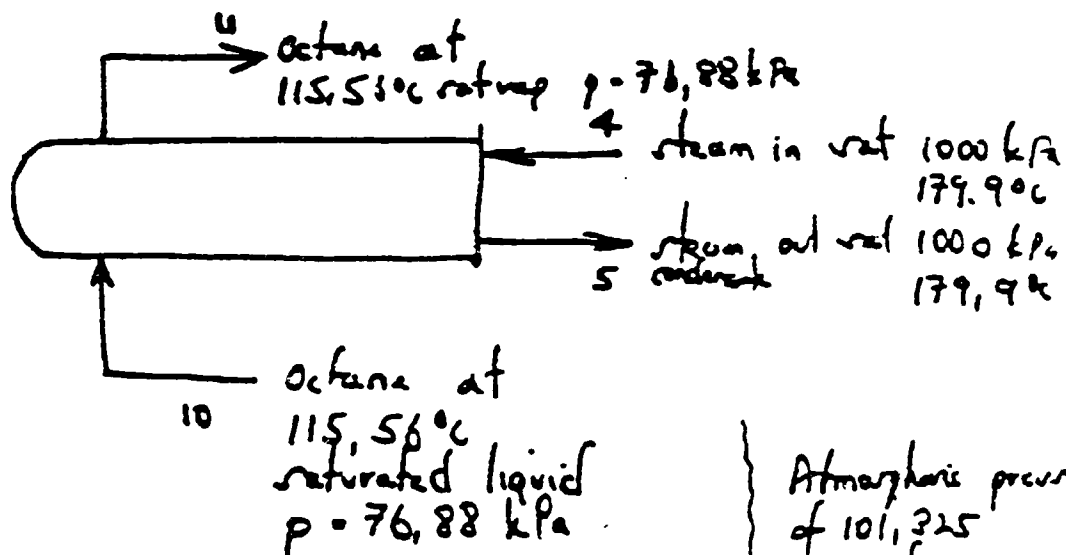

For the steam streams:

Base temp	$t_0 = 15^\circ\text{C} = 288,15\text{K}$
	$h_0 = 62,9$
	$s_0 = 0,224$

For the octane streams

Base temp	$t_{00} = 15^\circ\text{C} = 288,15\text{K}$
	$h_{00} = -1471,242 \frac{\text{kJ}}{\text{kg}}$
	$s_{00} = 3,17736 \frac{\text{kJ}}{\text{kg K}}$

Atmospheric press of 101,325 is used as standard. Liquid enthalpy & entropy at same temp are almost unaffected by pressure anyway

/Now

Now:

For stream 10

$$p_{10} = 76,88$$

$$t_{10} = 115,56$$

$$h_{10} = -1236,73$$

$$s_{10} = 3,7737$$

For stream 11

$$p_{11} = 76,88$$

$$t_{11} = 115,56$$

$$h_{11} = -925,75$$

$$s_{11} = 4,5552$$

$$\begin{aligned} \text{latent heat of water} &= 2015 = \lambda_w \\ \text{latent heat of octane} &= 310,98 = \lambda_o \end{aligned}$$

$$\begin{aligned} \text{Here mass flow of octane } \dot{m}_o &= \dot{m}_w \times \frac{\lambda_w}{\lambda_o} \\ &= 8,4832 \times \frac{2015}{310,98} \\ &= 54,967 \frac{\text{kg}}{\text{s}} \end{aligned} \quad \psi > 17,09 \text{ MW}$$

Specific Exergies

$$e_4 = (h_4 - h_0) - t_0 (s_4 - s_0) = 881,89 \frac{\text{kJ}}{\text{kg}_0}$$

$$e_5 = (h_5 - h_0) - t_0 (s_5 - s_0) = 148,58 \frac{\text{kJ}}{\text{kg}_0}$$

$$e_{10} = (h_{10} - h_{00}) - t_0 (s_{10} - s_{00}) = 62,68 \frac{\text{kJ}}{\text{kg}_0}$$

$$e_{11} = (h_{11} - h_{00}) - t_0 (s_{11} - s_{00}) = 148,47 \frac{\text{kJ}}{\text{kg}_0}$$

/Consequently

Consequently, actual energies become:

$$E_4 = 7,481.2 \text{ MW}$$

$$E_5 = 1,260.4 \text{ MW}$$

$$E_{10} = 3,445.3 \text{ MW}$$

$$E_{11} = 8,160.9 \text{ MW}$$

$$\text{Total Energy in} = E_4 + E_{10} = 10,926.5 \text{ MW}$$

$$\text{Total Energy out} = E_5 + E_{11} = 9,421.4 \text{ MW}$$

$$\underline{\text{Exchanger Efficiency} = 86.22\%}$$

ALTONA CRUDE 2 EXERGY BALANCE

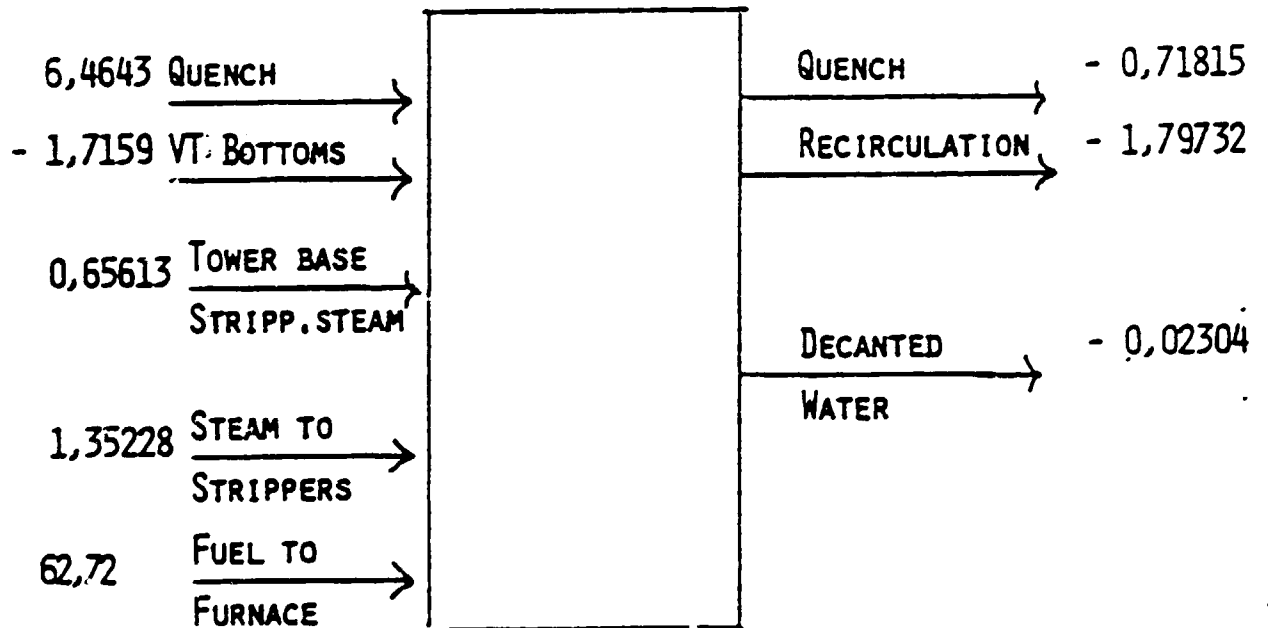
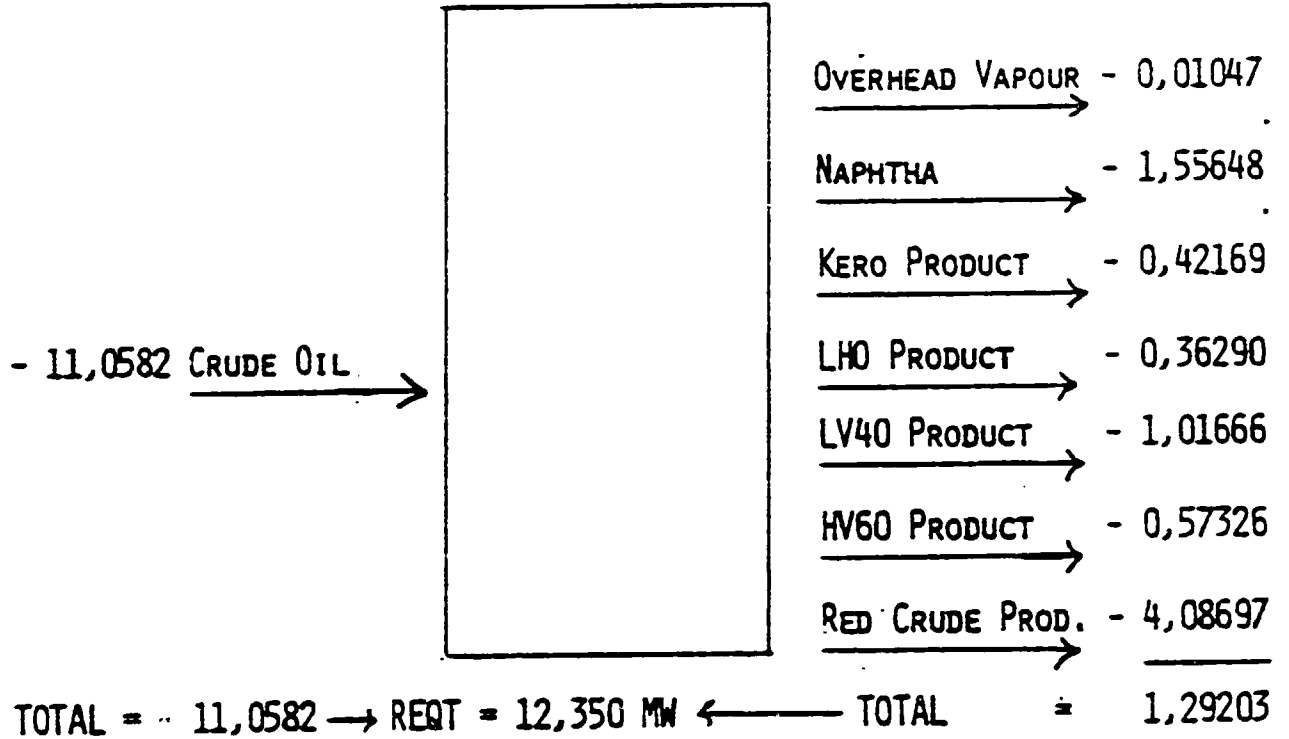

BALANCE IS BEFORE
AIR OR WATER COOLING
OR EXPORT

BALANCE IS IN MW OF EXERGY

ALTONA CRUDE 2 EXCHANGERS - EXERGY LOSSES

NUMBER REFER LEGEND ATTACHED	MW
1	0,1676
2	0,1679
3	0,3167
4	1,0583
5	0,7632
6	0,6774
7	0,4440
8	0,4899
9	0,4762
10	0,2773
11	0,0446
12	2,1380
13	- 0,0397
14	0,01889
15	0,39930
TOTAL	7,3996

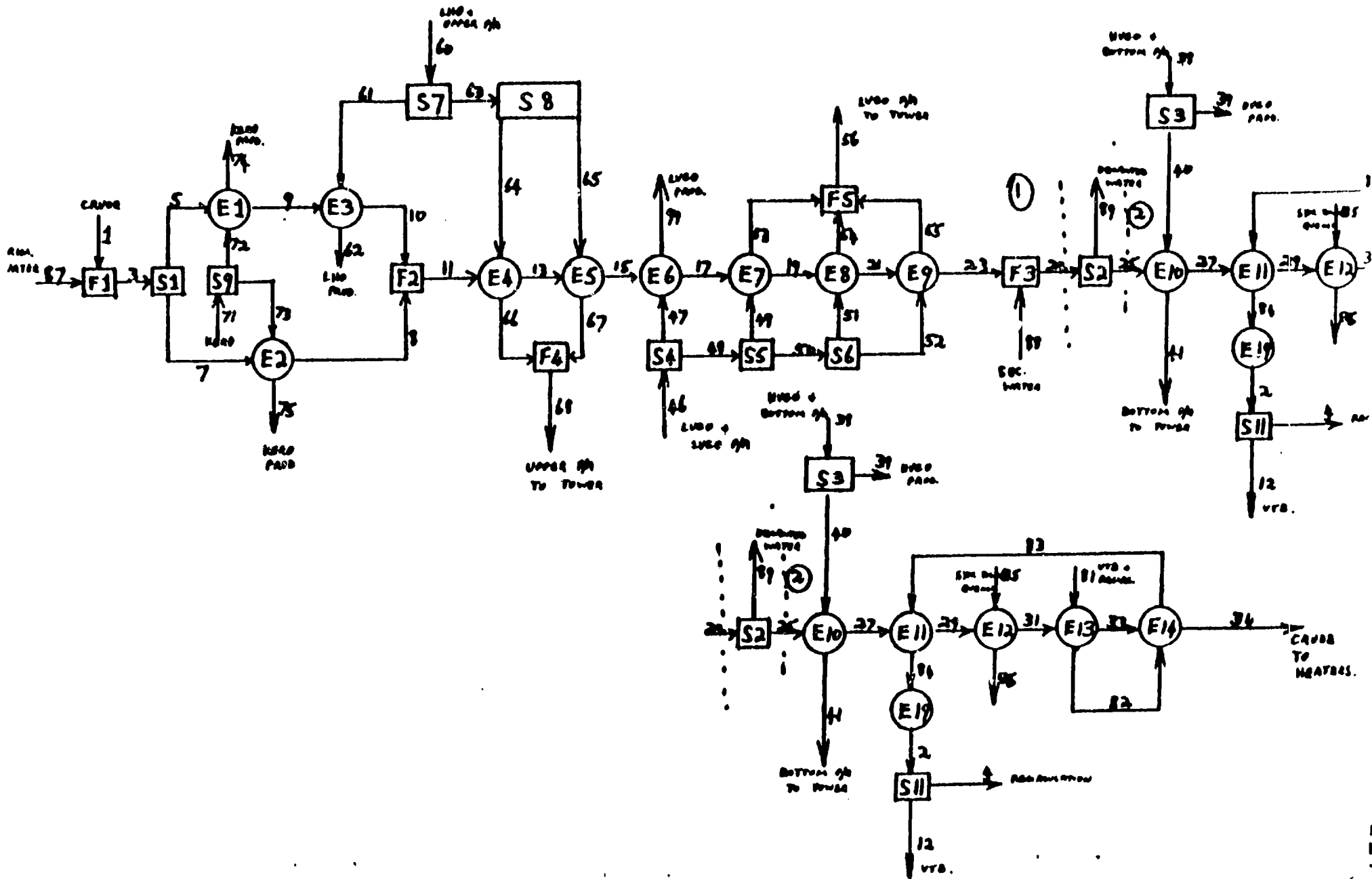

ENERGY LOSSES IN REFINERIES - CAUSES AND CURES

<u>TYPE OF LOSS</u>	<u>CAUSE OF LOSS</u>	<u>SIGNIFICANCE OF LOSS</u>	<u>METHOD OF REDUCTION OF LOSS</u>
Process of Combustion	Irreversible energy transfer from chemical to heat	A significant loss in every furnace and boiler	This loss is inevitable in combustion systems and cannot be reduced with present technology
Heat transfer - Combustion gas to Fluid being heated	Heat transfer temperature driving force	A very large loss in many refinery furnaces	Shutdown furnaces which provide low temperature heat in favour of steam. Balance work and heat requirements. Recover high temperature heat for work generation in hottest part of furnaces.
High Excess Air - Dilution of flue gas exergy	Dilution of high exergy heat in radiant section and increase of flue gas loss	A relatively large loss either at high excess air or with air leaks into furnace either in firebox or convection section.	Install forced draught with combined O ₂ /CO combustion control to accurately control air to fuel ratio.
Flue gas to atmosphere	Rejection of energy and exergy to atmosphere	Not very significant at moderate flue gas outlet temperatures (150°C)	Install equipment to reduce flue gas outlet temperature (eg BFW preheat) on small temperature approach.
Air Preheater losses	Temperature approach between flue gases and incoming air	A relatively small loss in modern air preheaters	Install an air preheater after BFW or other preheat for flue gas to preheat combustion air

EXERGY LOSSES IN REFINERIES - CAUSES AND CURES (CONTD)

<u>TYPE OF LOSS</u>	<u>CAUSE OF LOSS</u>	<u>SIGNIFICANCE OF LOSS</u>	<u>METHOD OF REDUCTION OF LOSS</u>
Loss to cooling water in condensing turbines	Rejection of a large quantity of very low quality heat to cooling water	Exergy loss is not significant relative to other exergy losses, but see next item	Wherever possible use exit steam for heating
Losses due to turbine inefficiencies	Loss due to friction in turbine	Exergy loss is almost negligible in modern high efficiency turbines operating in the saturation region but it is very large for all turbines operating in the saturation region. Some are only 10% efficient.	Balance heat and work requirements to avoid condensing turbines. Increase steam temperatures and pressures to recover sufficient work without need to operate in saturation region.
Heat exchanger losses	Larger than necessary temperature approach in exchangers	A very large loss in many refineries which manifests itself in an excess of low grade heat	Avoidable by redesigning the exchanger train to reduce approaches. Best results needed are obtained by reviewing the process simultaneously.
Distillation losses	Heat supplied by a reboiler or furnace to separate liquids by boiling point	Inefficient distillation towers needing high reflux are very wasteful	Redesign/retray to reduce requirement. Consider heat pumping overhead to provide duty of side or bottom reboiler and allow lower pressure lower energy (exergy) operation.

ENERGY LOSSES IN REFINERIES - CAUSES AND CURES (CONTD)

<u>TYPE OF LOSS</u>	<u>CAUSE OF LOSS</u>	<u>SIGNIFICANCE OF LOSS</u>	<u>METHOD OF REDUCTION OF LOSS</u>
Pumps and Compressors	Friction, and leakage from outlet back to inlet of stages	A moderate loss overall	Install equipment built to efficient designs, which allow much higher efficiencies than those often used in refineries. An easily avoidable loss.
Control valve losses	Friction taken across control valves	A moderately small loss overall	Avoidable by using variable speed pumps and by paralleling pumps for turnarounds of large duties.
Pipeline pressure drops	Pipeline friction	A moderate loss	Avoidable by increasing pipe size
Streams going to storage between processes	Loss due to the need for a temperature driving force in any cooling and reheating	A significant loss in most old refineries	Eliminate all non essential intermediate storage
Mixing and blending	Loss incurred by the energy needed to effect unnecessary separations	A moderate loss in some	Avoid the separation of materials to be reblended later, eg pentane and butane from motor spirit, or butane from propane beyond minimum spec requirements
Refrigeration expansion valve loss	Loss caused by throttling saturated liquid refrigerant	A significant loss in refrigerant systems	Install a device such as a hydraulic turbine to recover work

APPENDIX G.

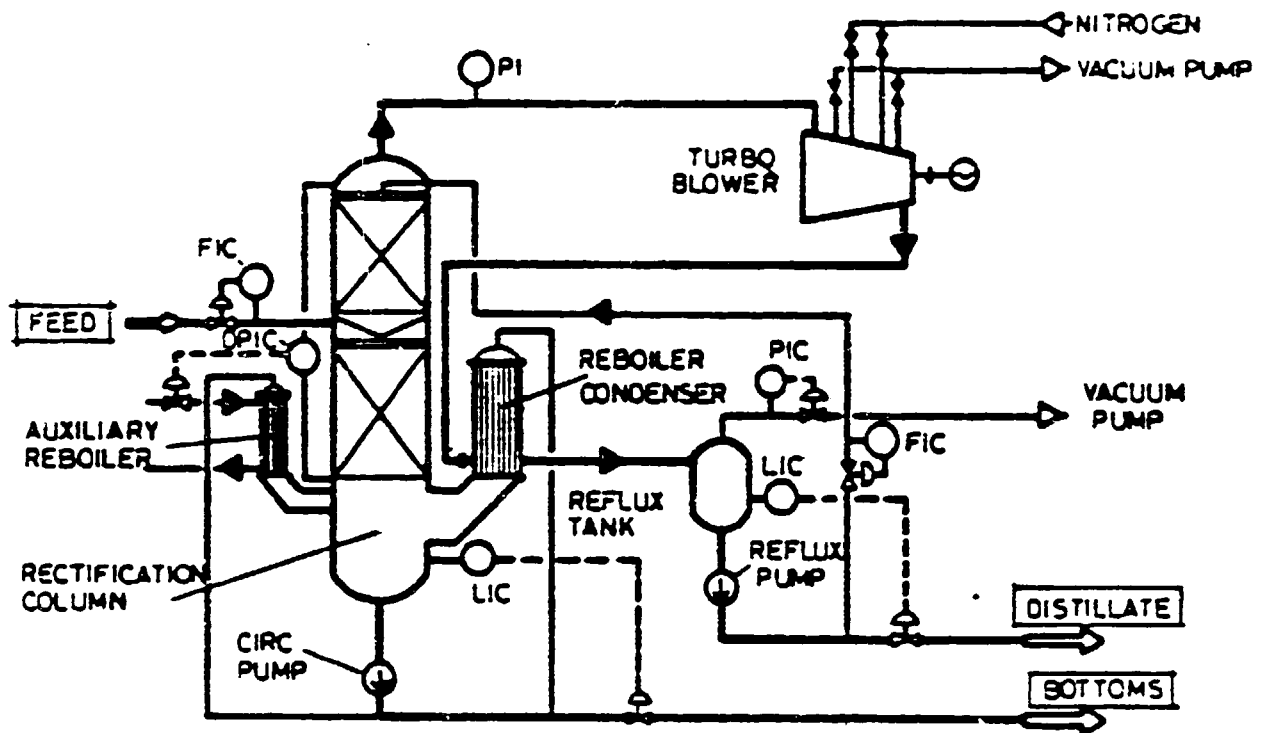

FLOWSHEET OF THE DISTILLATION PILOT PLANT WITH A HEAT PUMP

EXERGY LOSSES OF COMMON PROCESSESLOSSES DUE TO TEMPERATUREAPPROACH IN HEAT EXCHANGERSREBOILERS AND CONDENSERS

$$E_{\text{Loss}} = T_0 Q \left[\frac{1}{T_H} - \frac{1}{T_C} \right]$$

T_H = MEAN TEMP OF TRANSFER
FROM HOT FLUID

T_C = MEAN TEMP OF TRANSFER
FROM COLD FLUID

HEAT INTERCHANGER (CONSTANT CP)

$$E_{\text{Loss}} = T_0 Q \left[\frac{1}{T_{HLM}} - \frac{1}{T_{CLM}} \right]$$

T_0 = REFERENCE TEMP

Q = HEAT LOSS

LOSSES DUE TO PIPING, VALVEAND HEAT EXCHANGER TUBE FRICTION

$$E_{\text{Loss}} = MV \frac{T_0}{T} \Delta P$$

M = MASS FLOW

V = SPECIFIC VOLUME

ΔP = PRESSURE DROP

HEAT LOSSES FROM EQUIPMENT

$$E_{\text{Loss}} = -\Delta Q \left[1 - \frac{T_0}{T_M} \right]$$

TURBOEXPANDER

$$E_{\text{Loss}} = (W - W_s) \frac{T_0}{T_M}$$

W = ISENTROPIC WORK

W_s = ACTUAL WORK

APPENDIX I

POSSIBILITIES FOR IN PLANT ELECTRIC
GENERATION

SCHEME 1

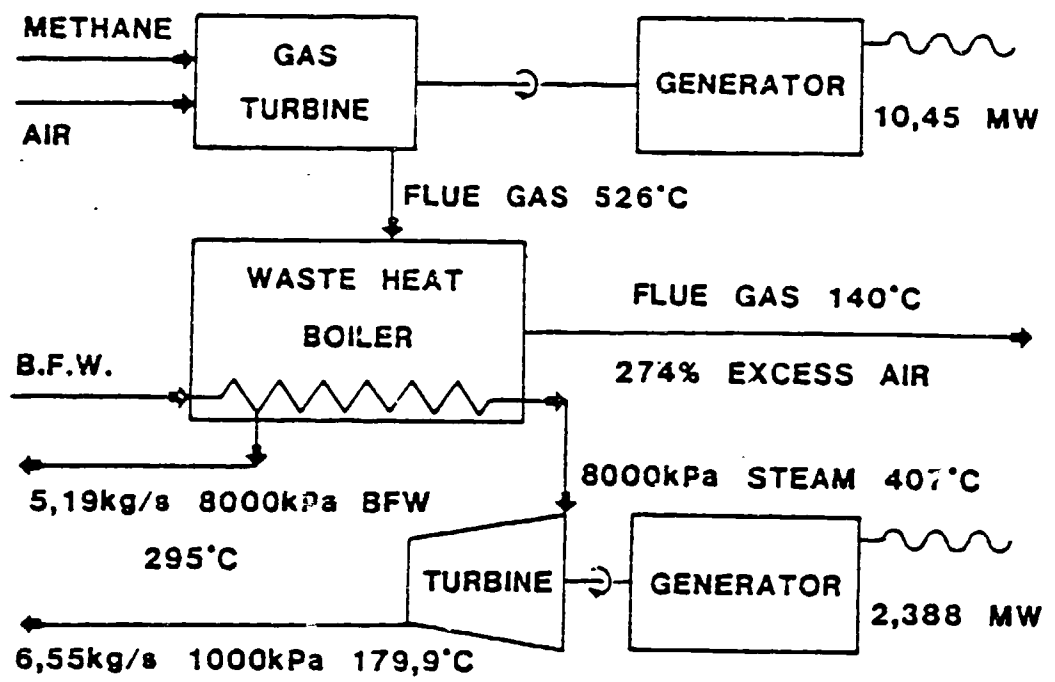

SCHEME 2

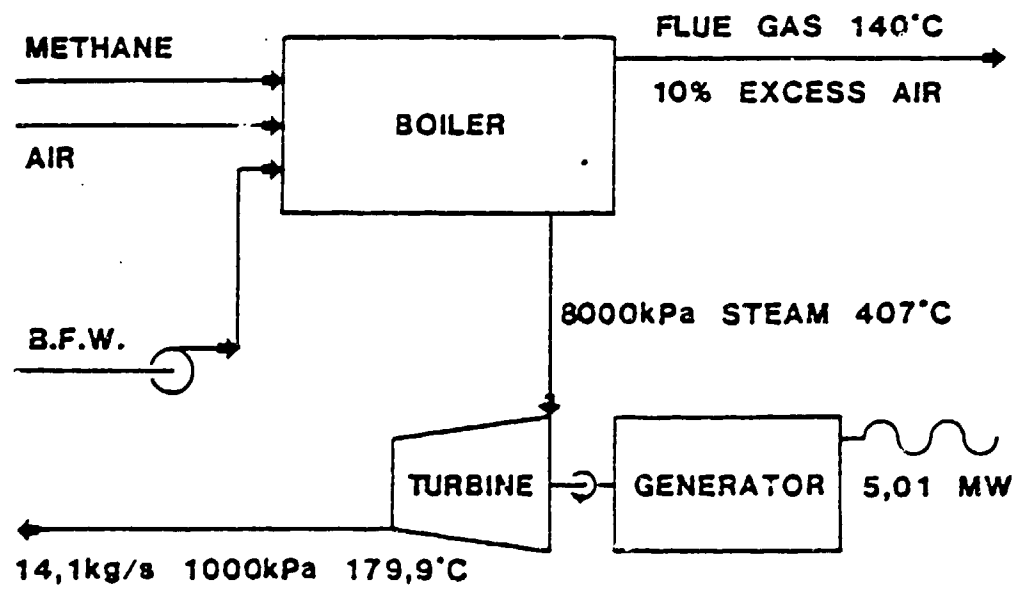

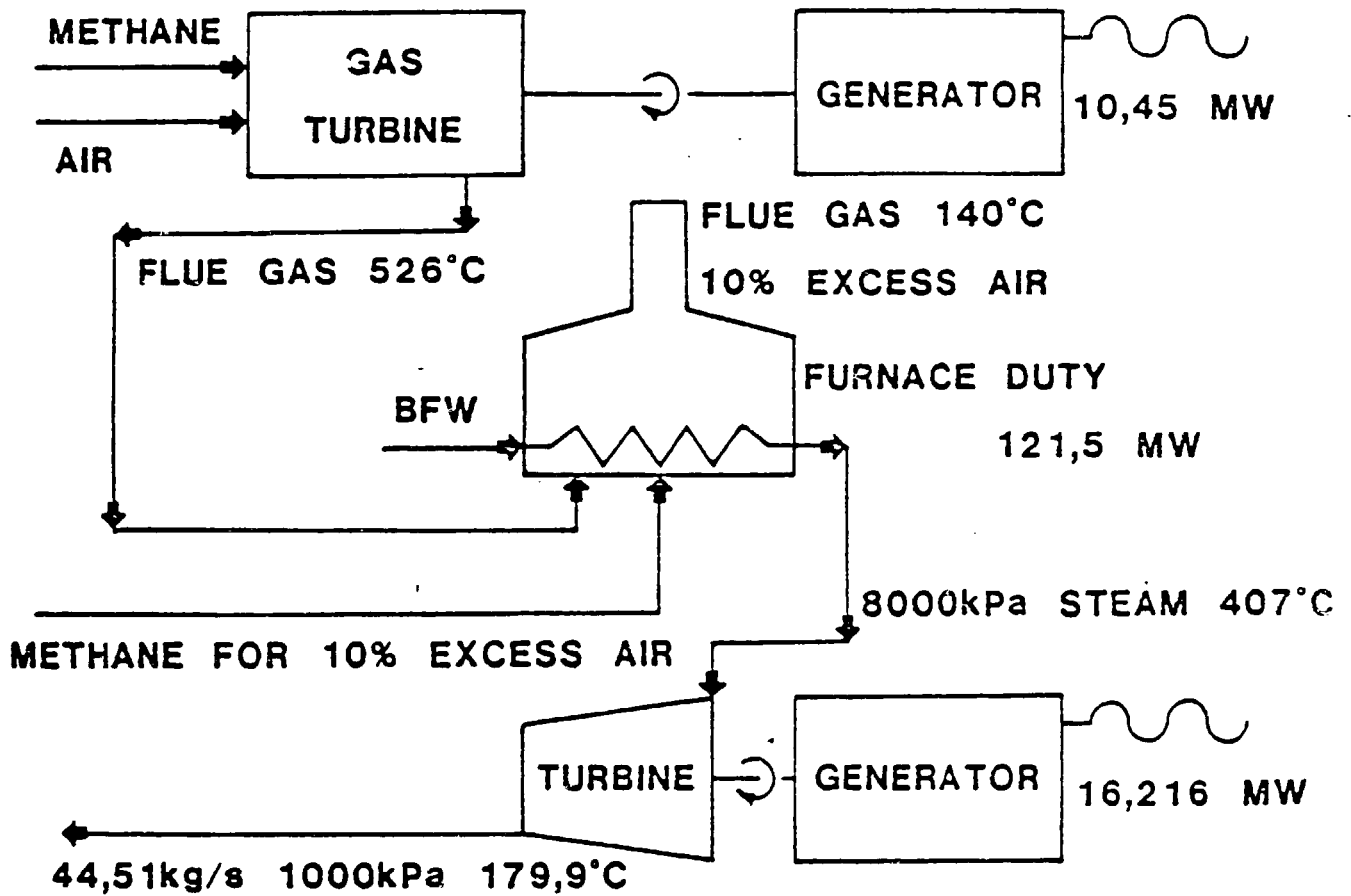
ELECTRIC GENERATIONSCHEME 3

AUSTRALIA/UNIDO WORKSHOP:

WASTE HEAT RECOVERY IN INDUSTRIAL PROCESSES
28th FEBRUARY — 11th MARCH 1983 MELBOURNE

HEAT EXCHANGER NETWORK
DESIGN BY ICI METHOD

Mr K.W. Davies
Energy Conservation Co-ordinator
Petroleum Refineries Australia

INTRODUCTION

Heat exchanger network design is an essential step in the design of an energy efficient flowsheet.

Historically, heat exchanger networks have been designed by matching streams in accordance with the best judgement of the engineer performing the design. Recent analyses have shown that this only rarely produces optimum designs. In fact, many early designs not only consumed a lot of unnecessary energy, they also featured an unnecessarily high capital cost occasioned by the unnecessarily large furnace, cooling towers and coolers.

The method developed by Linhoff and others at the ICI Corporate Laboratory provides a systematic technique for determination of the minimum hot utility and the minimum cold utility for any given economic minimum allowable t hot-cold in heat exchange. The technique provides a method for the design of an exchanger network which meets the minimum energy. For a revamp, this design is easily modified to incorporate existing exchangers.

Application of the method is facilitated by a computer program which performs the calculations.

SUMMARY

This paper provides a description of the procedure developed by ICI to give a minimum energy design for a given economical minimum temperature driving force.

The method is explained with the aid of a straightforward example which is solved step by step so that the reader can appreciate the steps involved. The solution is effected both by hand calculations and with the aid of the computer. The computer program used is provided in the appendices.

Finally, the method is applied to a more complex problem involving a rework of a crude distillation unit. The "before" and "after" configurations are given.

The computer method will handle up to 50 process streams each of which can have up to 12 temperature enthalpy points. It has the additional advantage that, given the stream starting and target temperature and temperature enthalpy data, the energy effectiveness of any design or system can be rapidly investigated.

HEAT EXCHANGER NETWORK DESIGN BY ICI METHOD

Acknowledgement

This paper has been developed based on the application of Petroleum Refineries (Australia) of the Heat Exchanger Network design technique developed by Linhoff and others at ICI in the United Kingdom. It was taught at the Energy Conservation course at the University of Queensland, Australia from November 26-27, 1981. The course notes have been ascribed a copyright to Professor Bodo Linhoff, Department of Chemical Engineering, University of Manchester, United Kingdom.

Experience versus "Pinch" Design Technique as Methods for that Exchanger Network Design

Traditional methods have customarily improved the energy consumption of refinery processes through experience using improved stream heat interchange methods each time a new design is made.

The ICI "pinch" design method determines the minimum hot utility required by an optimum match of the given process streams and provides a design which will achieve it:

DESIGN BY EXPERIENCE vs ICI METHOD

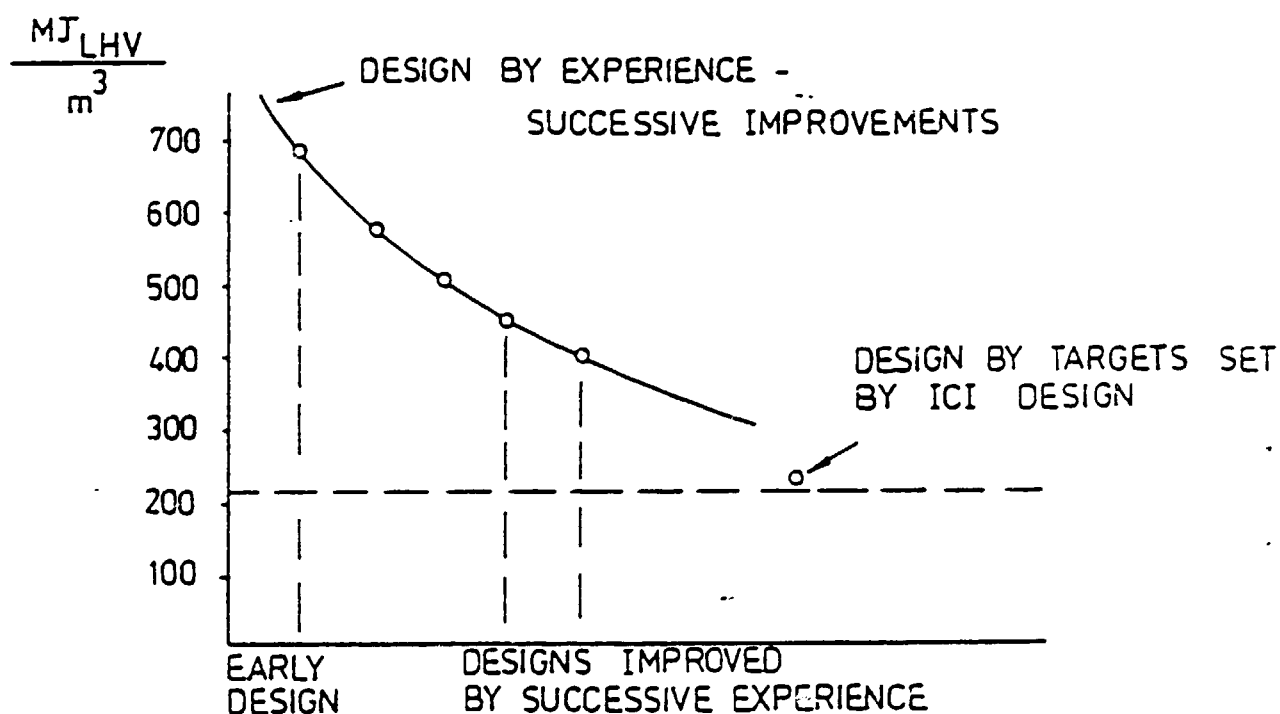

Principle Steps in ICI Design Method

The following steps are in performing a simple design:

- (a) Determine the stream temperature, its target temperature, mass flow and heat capacity, for each stream.
- (b) Calculate the "pinch", the tight point in the system.
- (c) Draw an exchanger network which meets the minimum heating and cooling requirements.
- (d) Relax the design to utilise as much existing equipment as possible.

Principle Steps in ICI Design Method (continued)

The aim of the sections immediately following is to show with the help of a straightforward system, how these calculations are carried out. Then, using the examples of the Altona Crude Unit No. 3, the Adelaide complete Lubricating Oil Refinery and the complete Adelaide Fuels Refinery, application of the method to complex systems is explained.

Temperature-Enthalpy Diagrams

An understanding of temperature-enthalpy diagrams as applied to heat exchanger networks is needed to appreciate the method. The diagram below shows a stream being heated and outlines the definition of terms used in the analysis:

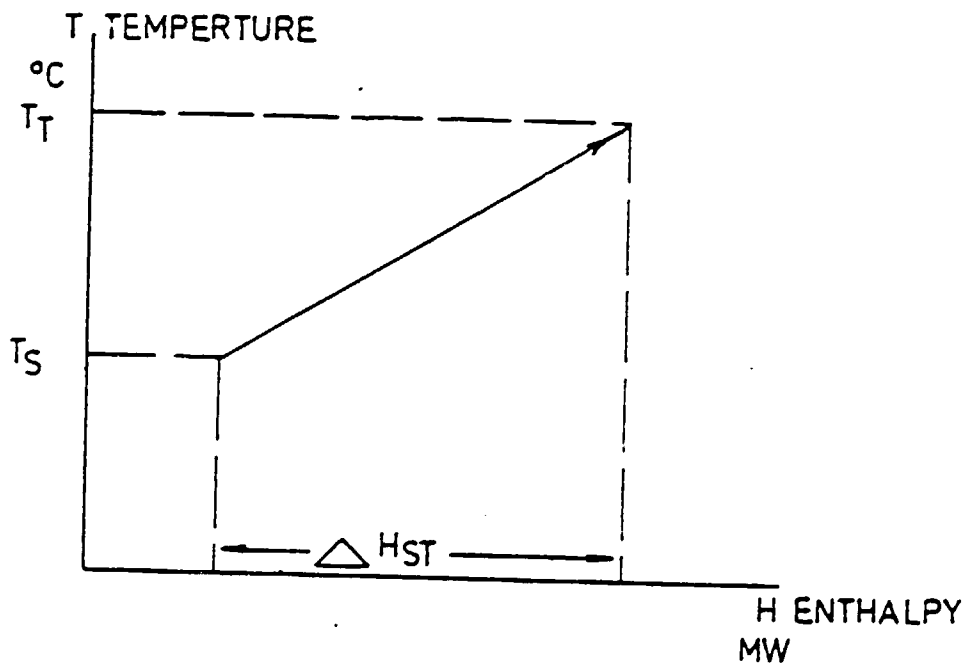

TEMPERATURE - ENTHALPY DIAGRAM

- T_S = STREAM SUPPLY TEMPERATURE (°C)
 T_T = STREAM TARGET TEMPERATURE (°C)
 ΔH_{ST} = STREAM ENTHALPY CHANGE (MW)
 CP = STREAM HEAT CAPACITY ($\frac{MW}{K}$)
 = STREAM FLOWRATE \times SPECIFIC HEAT CAPACITY
 $\frac{kg}{S} \times \frac{MJ}{kg K}$

Temperature-Enthalpy Diagrams (continued)

The diagram shows a straightforward hydrocarbon being heated in the sensible heat area. The more difficult cases of liquids for which CP is not constant, or mixed phases are dealt with later.

The following diagram shows a fluid being heated, a fluid being cooled and their representation on the temperature-enthalpy diagram:

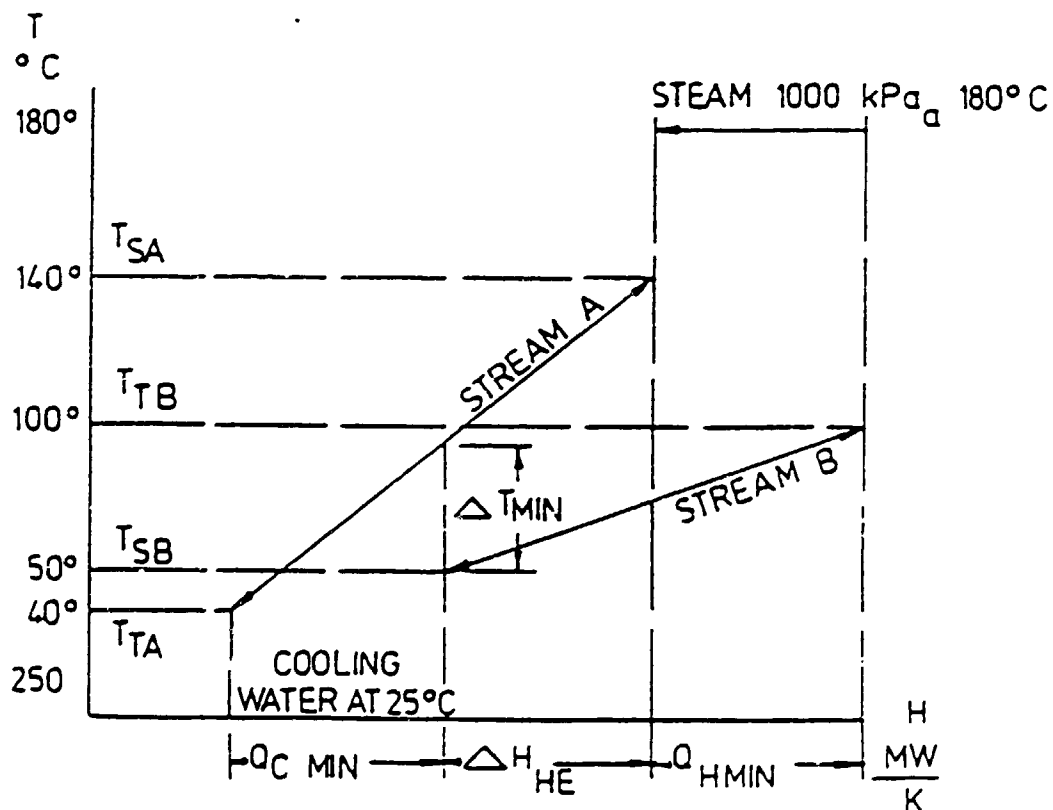
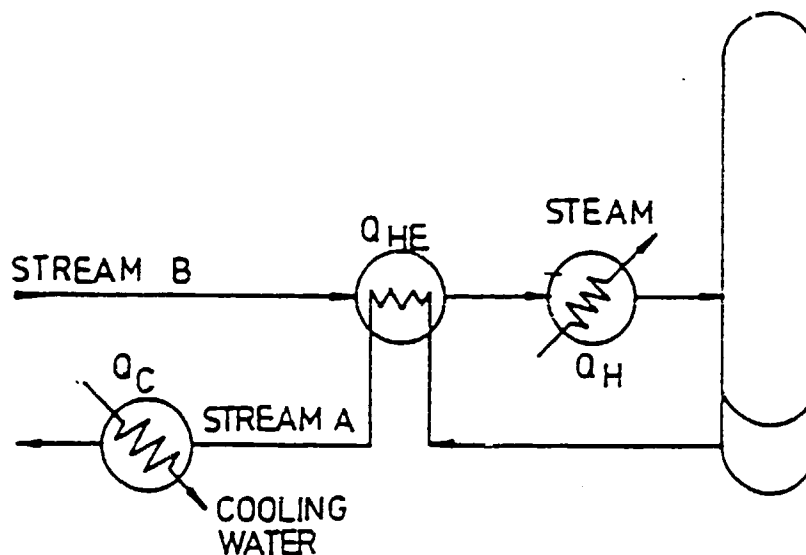

Temperature-Enthalpy Diagrams (continued)

The diagram shows the following key design criteria for this straightforward system:

T_{sa}	=	Stream A supply temperature
T_{ta}	=	Stream A target temperature
T_{sb}	=	Stream B supply temperature
T_{tb}	=	Stream B target temperature
ΔT_{min}	=	Tightest heat interchange approach temperature
Q_{hmin}	=	Minimum hot utility
Q_{cmin}	=	Minimum cold utility

Composite Temperature-Enthalpy Diagrams, Multiple Streams

Consider the following four streams being cooled across the temperature intervals shown:

MULTIPLE STREAMS

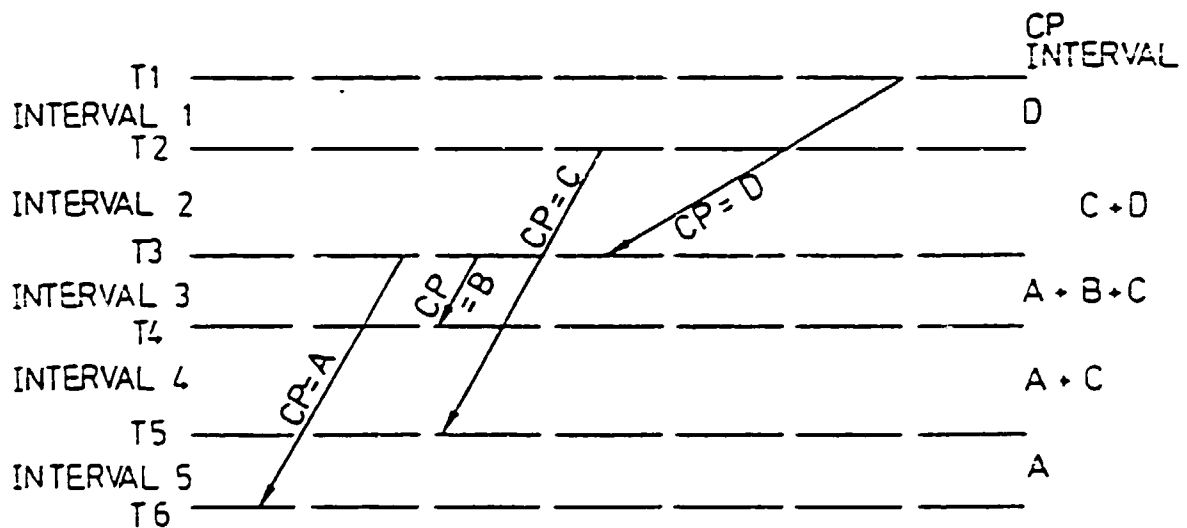

H for each interval becomes:

Interval	ΔH MW
1	$(T_1 - T_2) D$
2	$(T_2 - T_3) (C + D)$
3	$(T_3 - T_4) (A + B + C)$
4	$(T_4 - T_5) (A + C)$
5	$(T_5 - T_6) A$

Temperature-Enthalpy Diagrams (continued)

The corresponding T-H diagram becomes:

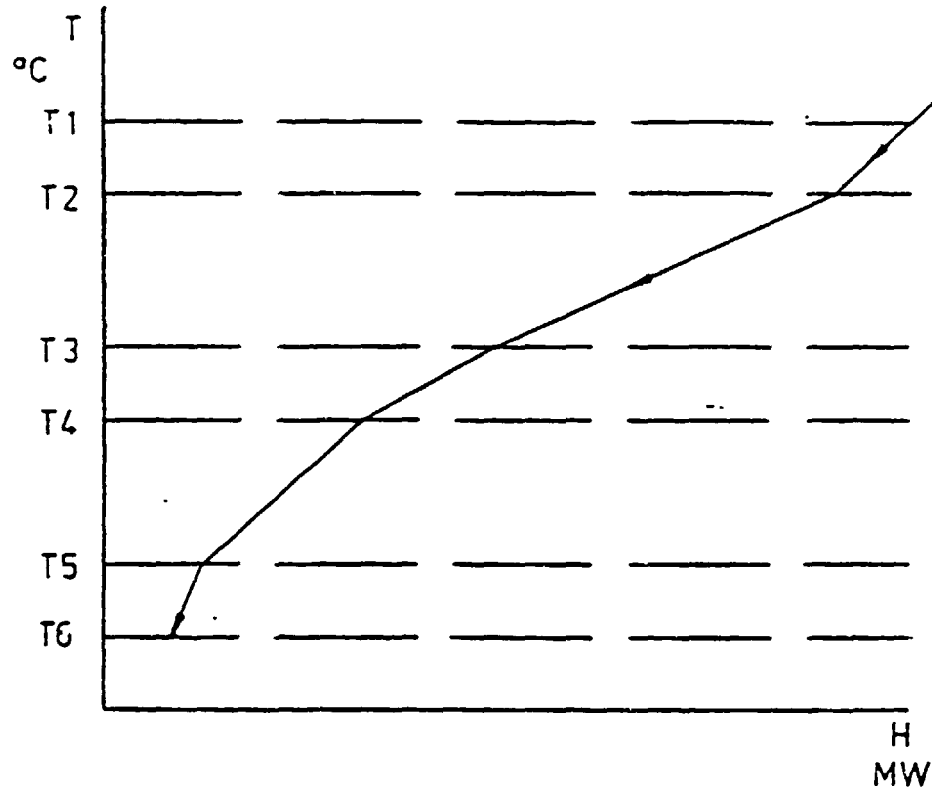
COMBINED T - H DIAGRAMThe Pinch

Using the foregoing method, a composite temperature-enthalpy diagram for all the streams requiring cooling and other line plotted for all the streams requiring heating. These two plots can then be placed on the same axes and moved horizontally towards each other or away from each other to yield differing amounts of hot and cold utility corresponding to increases and decreases in T_{min} :

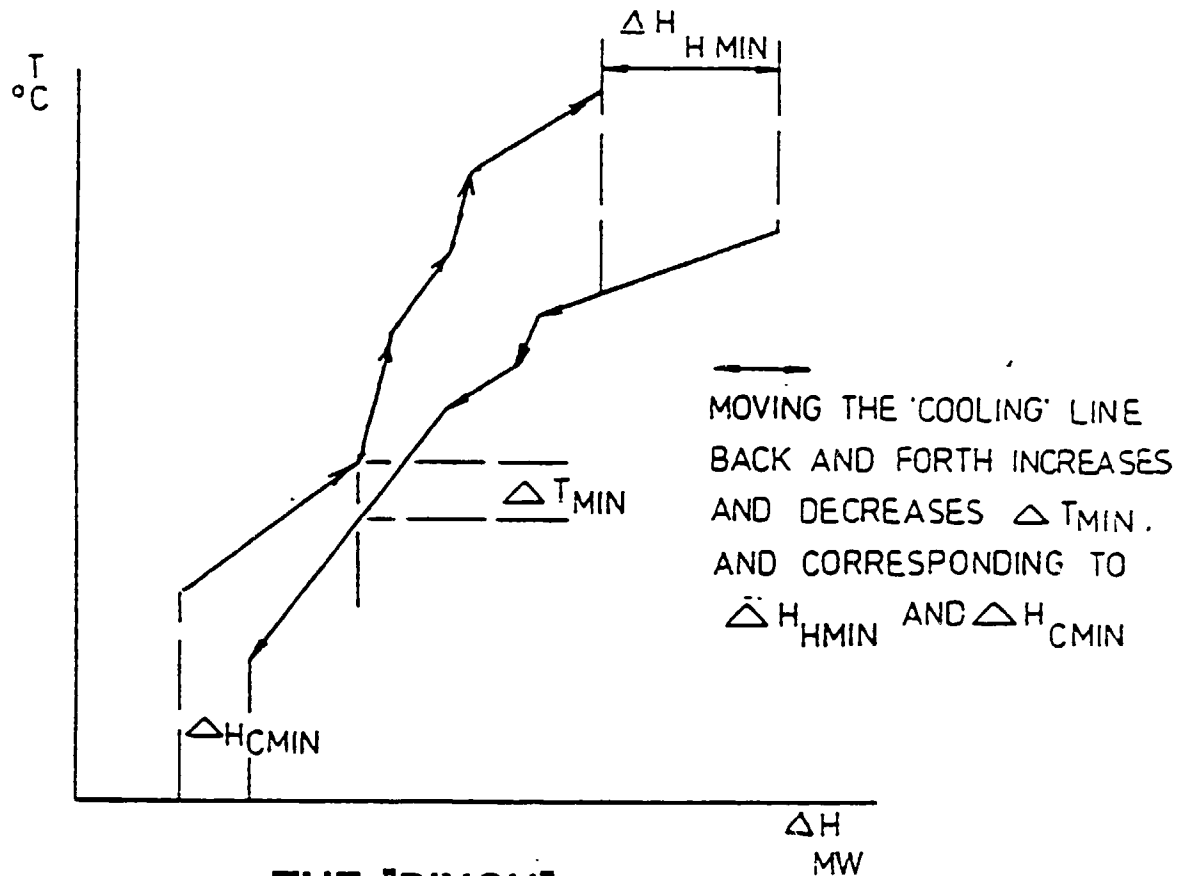

The Pinch (continued)

Having selected a value for ΔT_{min} which is considered to be an appropriate economic minimum at the tightest point in the heat exchanger network, the ΔH_{hmin} and ΔH_{cmin} can be immediately determined. The tight point in the network is termed the pinch.

It is at this point that the best design efforts need to be concentrated. The matching of hot and cold streams needs to be performed working outwards from the pinch towards the hot and cold ends.

The addition of extra heat beyond the minimum ΔH_{hmin} above the pinch, results in extra cooling by the same amount. The provision of any cooling above the pinch has the same effect.

Setting Design Targets

The determination of Q_{hmin} and Q_{cmin} for a given economic ΔT yield realistic design targets which form the goal of the low energy design.

$$\text{Target energy} = \Delta Q_{hmin}$$

Calculation of the "Pinch" location, Determination of Q_{hmin} and Q_{cmin} - Hand Calculations

This is accomplished by rigorous thermodynamic calculations. Data required is as follows; for each stream we need:

- (a) Stream supply temperature, T_s ($^{\circ}C$).
- (b) Stream target temperature, T_t ($^{\circ}C$).
- (c) Stream Heat Capacity, CP (MW/K) or alternatively, a table of enthalpy, ΔH (MW) versus temperature (K or $^{\circ}C$).

The method is explained using the following straightforward example for five process streams:

Stream No.	Stream	Supply Temperature T_s $^{\circ}C$	Target Temperature T_t $^{\circ}C$	Heat Capacity CP $\frac{kW}{K}$
1	Crude Oil	25	250	160,0
2	Debutaniser Reb	110	130	600,0
3	Kerosene Reflux	200	140	160,0
4	Gas Oil Rundown	240	40	55,0
5	Kerosene Rundown	200	40	15,0
6	Overhead Condens	120	90	350,0

FIG PINCH DESIGN EXAMPLE
RAW DATA

Estimate the minimum economical ΔT hot-cold to be $20^{\circ}C$.

Calculation of the "Pinch" location, Determination of Q_{hmin} and Q_{cmin} - Hand Calculations (continued)

The following tables are prepared:

Stream	$\frac{T_s}{T_t}$	$\frac{+\Delta T_{min}}{-2}$	Remove Duplicate	Set up Intervals
1 COLD	$\frac{25}{250}$	$\frac{35}{260}$		$\frac{260}{230}$
2 COLD	$\frac{110}{130}$	$\frac{120}{140}$		$\frac{190}{140}$
3 HOT	$\frac{200}{140}$	$\frac{190}{130}$		$\frac{130}{120}$
4 HOT	$\frac{240}{40}$	$\frac{230}{30}$		$\frac{110}{80}$
5 HOT	$\frac{200}{40}$	$\frac{190}{30}$	Duplicate Duplicate	$\frac{35}{30}$
6 HOT	$\frac{120}{90}$	$\frac{110}{80}$		

TEMPERATURE INTERVAL TABLE

INTERVAL STREAM POPULATION

$$\Delta H_j = (T_j - T_{j+1}) (\sum CP \text{ COLD} - \sum CP \text{ HOT})$$

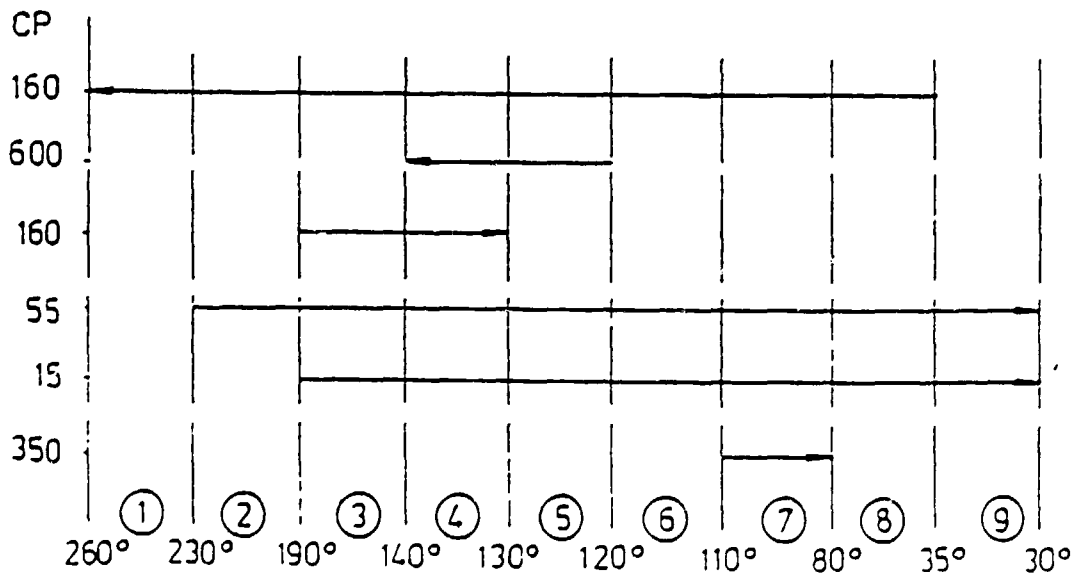

Calculation of the "Pinch" location, Determination of Q_{hmin} and Q_{cmin} - Hand Calculations (continued)

Now, for each interval:

$$H_j = (T_j - T_{j+1}) \left(\sum C_{pcold} - \sum C_{phot} \right)$$

Interval No.	$T_j - T_{j+1}$ K	$C_{pcold} - C_{phot}$ $\frac{kW}{K}$	H_j MW	H cumul MW
1	30	+ 160	- 4,80	- 4,80
2	40	+ 105	- 4,20	- 9,00
3	50	- 70	+ 3,50	- 5,50
4	10	+ 530	- 5,30	- 10,80
5	10	+ 690	- 6,90	- 17,70
6	10	+ 90	- 0,90	- 18,60
7	30	- 260	+ 7,80	- 10,80
8	45	+ 90	- 4,05	- 14,85
9	5	- 70	+ 0,35	- 14,50

This information is interpreted as follows:

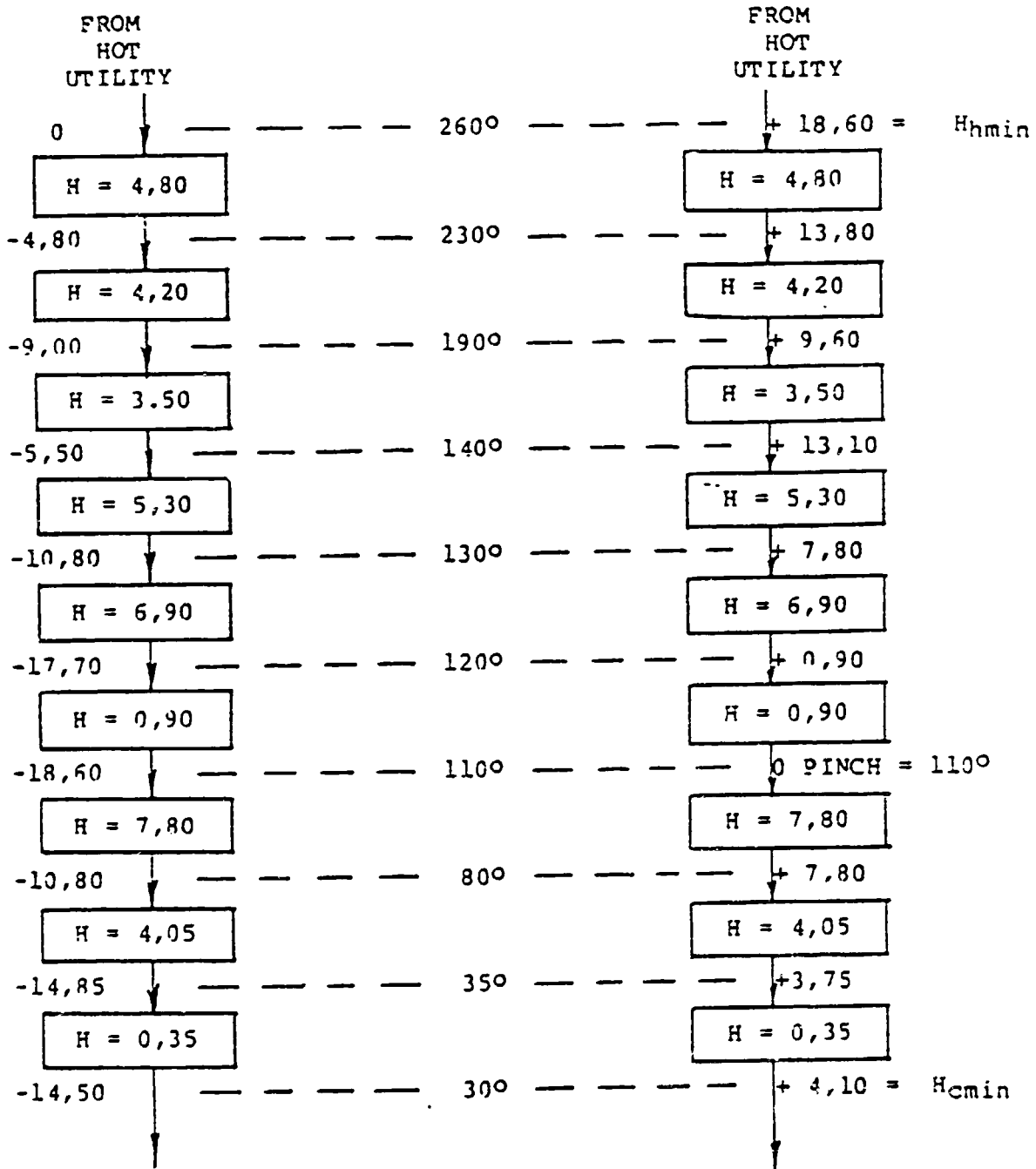

From the above table:

- (a) Pinch = 110°C
- (b) Minimum hot utility = 18,60 MW
- (c) Minimum cold utility = 4,10 MW

Computer Method for Determination of the Pinch, Minimum Hot Utility and Minimum Cold Utility

The computer method utilises the computer program RGMHENA. This program :

- (a) Accepts up to 50 streams.
- (b) For each stream, will accept up to 12 temperature-enthalpy data points, so that non-linear heat curves are easily handled.
- (c) Prints an output consisting of:
 - (1) Pinch Temperature
 - (2) Minimum Hot Utility
 - (3) Minimum Cold Utility
 - (4) Data for construction of Heat-Exchanger Network

The program steps are listed in Appendix A. Instructions for the use of the program appear in Appendix B.

Data input for the foregoing example is as follows:

APPROACH TEMPERATURE:		20				
Stream No.	Stream	Start T	Target T	No. of T-H Points	T	H
1	Crude Oil	25	250	2	25 250	0 36,00
2	Debutaniser Reboiler	110	130	2	110 130	0 12,00
3	Kerosene Reflux	200	140	2	140 200	0 9,600
4	Gas Oil Rundown	20	40	2	40 240	0 11,000
5	Kerosene Rundown	200	40	2	40 200	0 2,400
6	Overhead Condenser	120	90	2	90 120	0 10,500

The computer output appears in Appendix C.

Significance of the Pinch

The pinch is the point in the network at which the minimum heat interchange temperature approach ΔT_{\min} is actually reached. Often it need be the only point. Note that ΔT_{\min} is not the same as ΔT_{lm} .

The pinch is a very significant point in the network:

- (a) Do not cool with utilities above the pinch. Cooling above the pinch also increases hot utility usage by the same amount.
- (b) Do not heat with hot utilities below the pinch. Heating below the pinch also increases cold utility usage by the same amount.
- (c) Do not use heat pumps below the pinch. Their duty could be substituted by heat interchange.

Notation for Drawing Heat Exchanger Networks

The ICI method requires a different notation for the drawing of heat exchanger networks. The reasons and benefits will be apparent when some worked examples are carried out. The procedure is as follows:

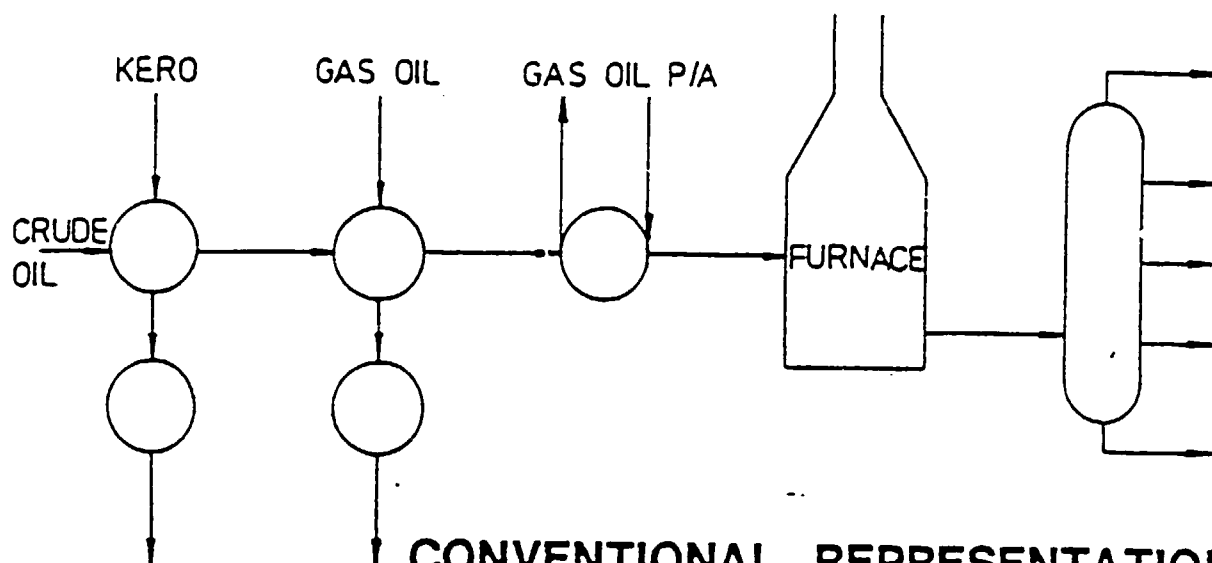

CONVENTIONAL REPRESENTATION

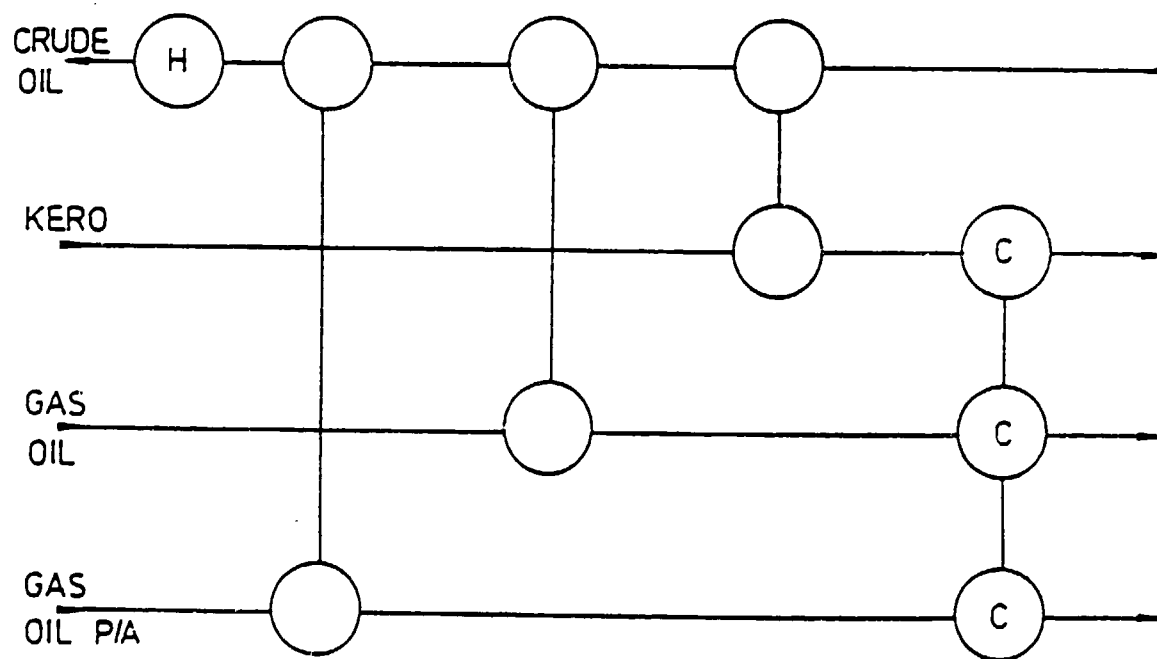

REPRESENTATION FOR USE IN PINCH DESIGNS

HEAT EXCHANGER NETWORK REPRESENTATION

Design for Maximum Energy Recovery

This is effected using the information calculated above. The problem is divided at the pinch. The designer moves away from the pinch first towards the hot end, then towards the cold end, making stream splits as necessary to satisfy the following requirements:

(a) Immediately above the pinch

$$(1) N_{hot} \leq N_{cold} \quad \begin{matrix} N_{hot} & \text{No. of hot streams} \\ N_{cold} & \text{No. of cold streams} \end{matrix}$$

$$(2) C_{Phot} \leq C_{Pcold} \quad \text{for each stream match}$$

(b) Immediately below the pinch

$$(1) N_{hot} \geq N_{cold}$$

$$(2) C_{Phot} \geq C_{Pcold} \quad \text{for each stream match.}$$

The techniques for the application of the above rules are learned by practice. However, the final solution must run with the minimum utilities determined in the pinch calculation. During the design, attempt to completely satisfy the duties of streams so that no utilities are required for them. For the problem previously presented, the minimum energy design would be as follows:

MINIMUM ENERGY SOLUTION - SAMPLE PROBLEM

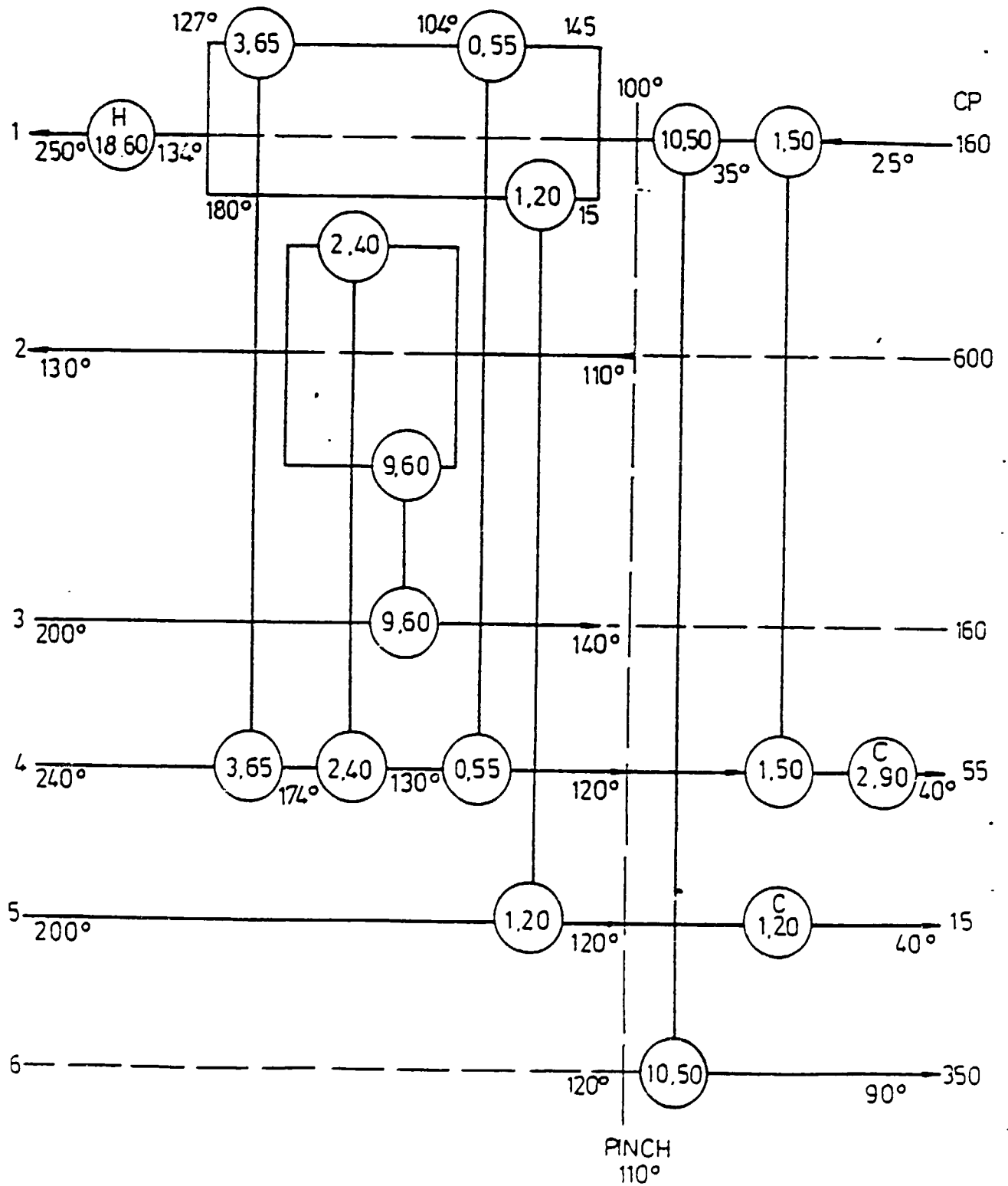

Design for Maximum Energy Recovery (continued)

Except at the pinch, there is usually some choice with the stream matches. You choose the one you want for control, or other reasons.

Keeping capital costs down is effected by:

- (a) Making exact matches to "tick off" stream wherever possible.
- (b) Eliminating the small exchangers wherever practicable.

In the above example, only a small penalty would be incurred for the elimination of the 0,55 MW crude/gas oil exchanger. Allowing the kerosene rundown to approach the crude to within 15° would allow a kerosene/crude interchanger to replace the gas oil/crude interchanger, eliminate the kerosene cooler and preserve the gas oil rundown as a good quality heat export for use in a low temperature application.

The conventional diagram for the minimum energy solution would be:

Design for Minimum Number of Units

The minimum number of units which would be possible to meet the design heat requirements is given by:

$$U_{\min} = N - 1$$

where

$$U_{\min} = \text{minimum number of units including heaters and coolers}$$

$$N = \text{number of streams including utility streams}$$

This solution is normally not synonymous with minimum energy.

Retrofit Designs using Computer Programs RGMHENA, QUIKBAL and HTRIST5

This procedure has been developed to integrate the ICI heat optimisation technique with the existing Mobil Programs QUIKBAL and HTRIST5 (Mobil version).

The method will handle up to 50 streams with heat curves involving up to 12 temperature-enthalpy points.

Steps in the design sequence are as follows:

1. Make a QUIKBAL model of the unit. *(for non Mobil people use Simri program)*
2. Assume for the present that there are no existing exchangers i.e. design from scratch.
3. Extract from QUIKBAL the necessary data to use in RGMHENA.
4. Run RGMHENA.
5. Perform a hot/cold stream match as above to yield the minimum energy design.
6. Make a QUIKBAL model of the minimum energy proposal.
7. Relax the design to get reasonable exchanger sizes and number of shells.
8. Attempt to match exchangers currently installed against those required in the new design based on the UA table in QUIKBAL and materials of construction.
9. Run detailed exchanger program HTRIST5 in the "rating" mode to verify exchangers which can be re-used, together with any shell/tube modifications needed, and in the "design" mode for new exchangers.

Retrofit Designs using Computer Programs RGMHENA, QUIKBAL and HTRISTS (continued)

10. Put UA valves and numbers of shells into QUIKBAL and determine expected operation.
11. Evaluate control and operational problems.

Altona Crude 3 Redesign Study

The Altona Crude Unit No. 3 was simulated in accordance with the foregoing procedure. The study involved the requirement to install a new LGO pumparound to transfer some tower heat removal from below the pinch (kerosene pumparound) to above the pinch (LGO pumparound).

The resulting design is shown in Appendix D. Estimated POG of the final design is about 130. This assumes that sufficient sinks for the high temperature ride stream heat exports can be found in the Alkylation unit. Further improvement is possible by low level heat recovery if economics allow.

A similar study was completed for the combined Altona Crude 2/ TCC/Sat Gas Plant/Unsat Gas Plant revealing potential for enormous improvement. Projects are being developed to implement these studies.

Heat Cascade Diagram

This diagram is a graphical representation of the enthalpy (ΔH) versus temperature (T) information, interval by interval.

It shows graphically the potential for heat cascade down through the system. It also shows the potential for the addition of low grade utilities at low temperatures.

Some Heat Cascade diagrams are given in the appendices. The Altona Crude Unit 3 is given in Appendix E, the complete Adelaide fuels Refinery in Appendix F and the complete Adelaide Lubricating Oil Refinery in Appendix G (each excluding process steam and tank heating).

The Adelaide Lubricating Oil Refinery diagram shows the potential to cascade Vacuum Tower furnace heat down through the hot end of the plant, but that a lot of low level heat of approximately 120°C is needed. This could conceivably be supplied by turbine exhaust, if enough mechanical work is needed to exhaust this large amount of low level heat or otherwise by heat pumps operating in the PDA and Fuel Units.

Much of the graph for the Adelaide Fuels Refinery is very flat, and comparison with the existing plant energy usage indicate that carefully designed heat exchange could effect much improvement. This will be the subject of ongoing investigations.

LIST OF REFERENCES

1. Bodo Linhoff and John A. Turner "Heat Recovery Networks : New Insights Yield Big Savings"; Chemical Engineering, 2 NOV 81, pages 56-70
2. D.W. Townsend and B. Linhoff "Designing Total Energy Systems by Systematic Methods"; paper presented to "Total Energy Design in Process Plants", I.Chem.E./SCI Conference London 29 APR 81.
3. B. Linhoff and J.A. Turner "Simple Concepts in Process Synthetics Give Energy Savings and Elegant Designs"; Chemical Engineer, DEC 80, pages 742-746.
4. Editor L.S. Leung "Heat Exchanger Network Design"; course notes from Energy Conservation Course held at University of Queensland NOV 1981.

CRUDE EXCHANGER NETWORK

LOW ENERGY DESIGN (PRELIMINARY)

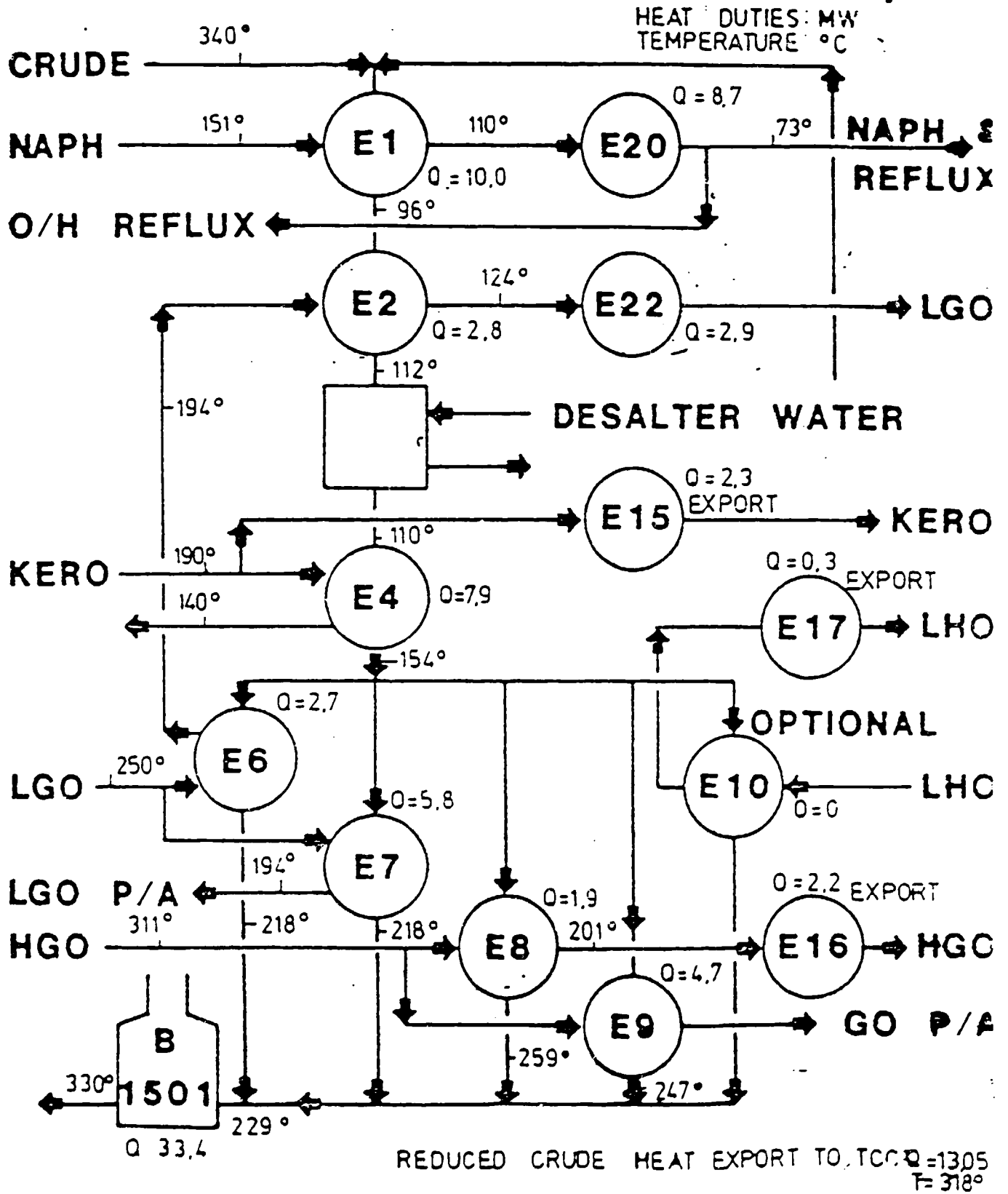

Note that finalised design was not available at the time of going to print

CRUDE EXCHANGER NETWORK

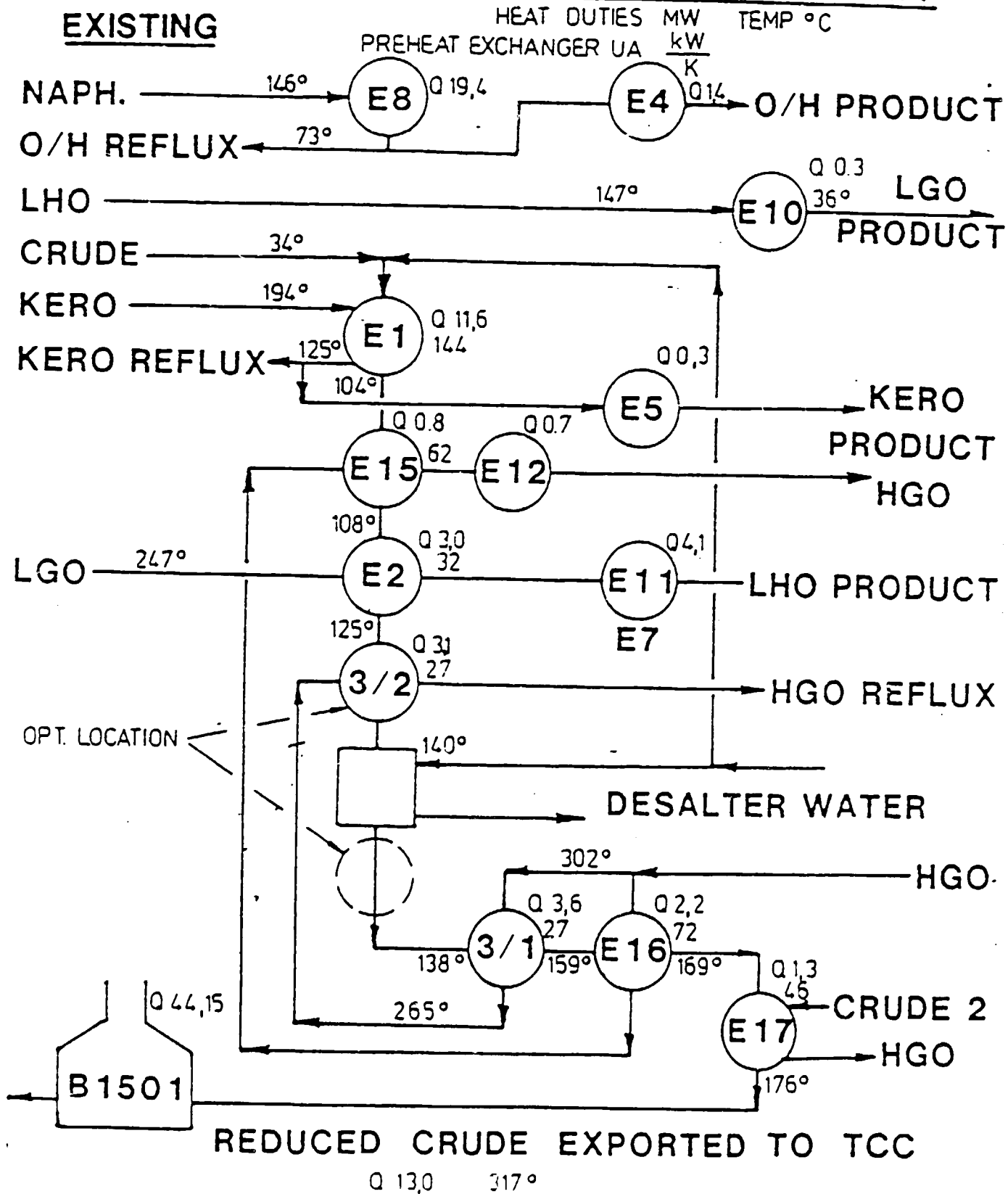

ALTONA CRUDE HEAT CASCADE

$\Delta T_{min} = 25^{\circ}C$

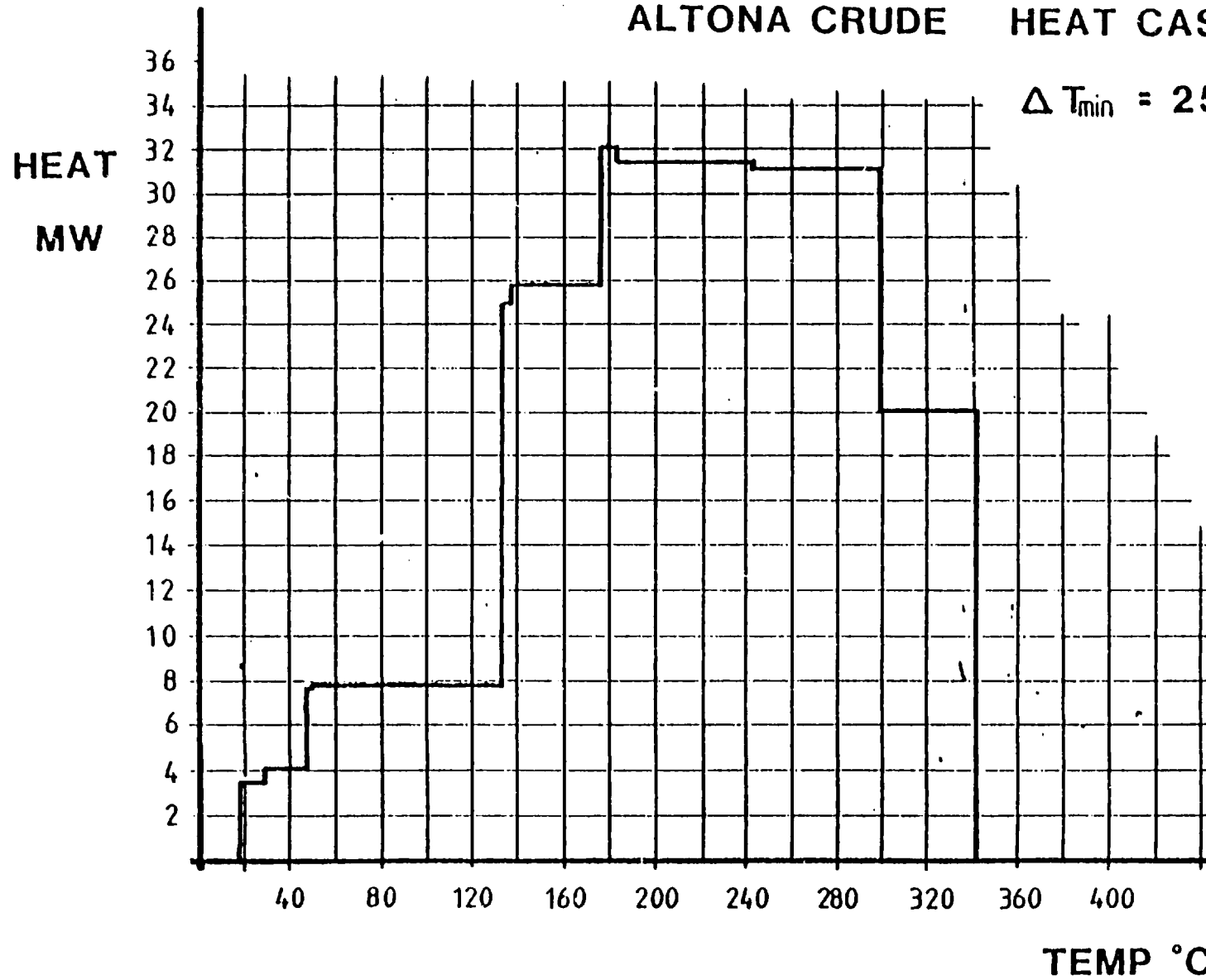

AUSTRALIA/UNIDO WORKSHOP:

WASTE HEAT RECOVERY IN INDUSTRIAL PROCESSES
28th FEBRUARY — 11th MARCH 1983 MELBOURNE

- . CONVERSION BURNERS
- . SUSPENSION BURNING OF WOOD AND
AGRICULTURAL WASTES
- . MUNICIPAL REFUSE BURNING

Mr K. Gordon
President
Peabody Gordon & Piatt

CONVERSION BURNERS

Thank you for inviting me to be present at this energy workshop and the sharing of experience on this timely and important topic of "Waste Heat Recovery".

Rather than being lulled into complacency during this recent period of lower oil prices we should take the advantage of this opportunity to improve the efficiency of our processes and fully utilize our waste fuels to become more competitive and be less vulnerable to future energy increases.

As my background is in manufacturing, this mornings session will deal with some of the hardware and the application and installation of equipment involved in waste heat recovery systems. The general areas of discussion will be:

1. General information on PGP and "Conversion Burners".
2. Suspension Burning of Wood and Agricultural Wastes using the "SF" Burner.
3. Municipal Refuse Burning using the "RGF" Rotary Grate Furnace.
4. Waste Heat Recovery from Boiler Stacks using the "HEATMISER" condensing type economizer.

Peabody Gordon-Piatt, located at Winfield, Kansas, is a wholly owned subsidiary of Peabody International of Stamford, Connecticut. Peabody International is a New York Stock Exchange Company, with annual sales of US \$450 Million. The firm employs 5,000 people in 65 locations throughout the world. Major markets include energy, environmental and agricultural, with a variety of products including combustion, air handling, gas cleaning, waste services and equipment, and design and construct projects.

The combustion equipment is manufactured by two Companies, ourselves and Peabody Engineering Company of Stamford, Connecticut. Peabody Engineering makes the larger burners (Register Type) for the industrial and utility markets. We, at Winfield, Kansas make the smaller size burners for .5 to 50 Million BTU/HR input for the commercial, institutional and industrial markets.

Our main speciality is the burner itself rather than the boiler, furnace or heat exchanger into which the burner is fired. The burner is usually completely assembled with its combustion air fan, gas or oil controls and control panel arranged in a package ready to attach to the combustion chamber of the pressure vessel or heat exchanger. About one half of our sales are as replacement or conversion burners with the remainder being sold to boiler manufacturers as original equipment.

The "replacement market" at present is the upgrading to more efficient burners, or replacement of single fuel gas or oil burners with dual fuel models. For example, the Dallas School system recently converted from a variety of about 20 different burners, installed over 25 years, mostly of the atmospheric gas type to one type of forced draft gas oil burner throughout their entire system of 300 boiler rooms. Boiler combustion chambers were re-worked for pressure firing with reduced excess air, air leaks to the combustion chamber were sealed and overall efficiency raised at least ten per-cent. Operating costs were further reduced by simplifying maintenance and reducing the variety of spare parts required.

Modern burners are designed to operate with less excess air, particularly at the lower firing rates. When compared to atmospheric gas burners, the forced draft gas burner has considerably less "off" period or "Stand By" loss. Burners in the size range 10 to 300 GPH of oil and the equivalent gas usually modulate to low fire much of the time. Normal "turn down" from high to low fire is 3 to 1, therefore if 1/3 firing rate is too much for the load the boiler shuts off. Air flow through the burner and combustion chamber during the "off" period wastes heat and therefore it should be minimized. Modern burners and boilers accomplish this with a fairly high pressure drop across the burner and boiler.

Modern burners save fuel and are part of an energy conservation program. Many times there are funds available to replace and/or "tune up" the burner where the complete boiler unit cannot or is not necessary to replace.

SUSPENSION BURNING OF WOOD AND AGRICULTURAL
WASTES

The "SF" or Solid Fuel burner is designed to use waste wood or similar biomass fuels that are ground to a size that will burn primarily in suspension in the combustion chamber.

Not over approximately 10% of the fuel can be of a larger size (1/8" x 1" Max.), these larger particles normally fall to the combustion chamber floor and burn on the pin hole grate. The moisture content of the fuel is usually held under 15% (wet basis).

The burner normally fires directly into the combustion chamber that is a part of the boiler firebox. The combustion chamber will usually have refractory surfaces to 2 or 3 feet above the burner center line and sufficient volume to provide 30 to 40,000 BTU/CF of heat release.

Sufficient excess air is used to keep the combustion chamber temperature below the ash fusion point (Approximately 2,000°F).

It is common practice in the U.S. to burn the wood waste generated by wood processing plants to produce steam for kilns for drying lumber or other processes such as drying of wood chips with rotary dryers for the production of particle board. When the waste fuel is available on the site it saves both hauling costs to dispose of the waste and the cost of the fuel if the heat is required in the process.

The SF Burner is a part of a complete system that has been developed to burn the specific type of waste fuel. We have found that the systems approach is absolutely necessary for a successful operation as each part of the system must work properly and in concert, including fuel storage, fuel preparation, conveying, metering, burning, ash removal and emission control.

The ash is removed from the combustion chamber manually. When burning bark (3.5% ash content), the chamber floor is usually cleaned once per shift while with white wood waste (1/2% ash) cleaning once per week is sufficient. Approximately half of the ash is carried through the boiler and removed with a multiple cyclone mechanical fly ash collector. This is usually sufficient to meet emission codes in the U.S. except in areas of high population densities such as the West Coast where a baghouse, scrubber or ESP may be required for particulate removal.

The SF burner uses a standard gas, oil or dual fuel burner as the support or ignition burner. On first light-up the gas or oil preheats the combustion chamber at the pre-set warm up rate for sufficient time to get the chamber to 1200-1400°F. The waste fuel is then introduced at a low fire rate with the support burner also at low fire. After stabilizing (3-5 minutes), the support burner turns off and the waste fuel modulates (3:1 Turndown) to meet the steam demand of the boiler. If necessary in case of waste fuel shortage, the support burner is capable of supplying the full input to the boiler.

The fuel is stored in a silo of sufficient size to supply the burner through periods of plant shut down such as nights or week-ends when steam may be required. The unloading device must be capable of minimizing fuel flow stoppages due to bridging.

The waste fuel is metered from a surge bin that is also specially designed to prevent bridging problems and to provide even fuel flow at the rate of boiler demand. It incorporates a live bottom floor of screws driven by a variable speed D.C. drive. The screws unload into the pneumatic fuel conveying line to the burner.

Overfire and undergrate combustion air is supplied by separate combustion air fans with damper controls which modulate flow in accordance with the fuel feed rate. A higher proportion of undergrate air is used if the fuel has a higher moisture content.

An overfire draft control system controls the damper between the I.D. fan and the boiler. A constant negative draft is maintained in the combustion chamber of approximately 0.5" W.C.

Separate flame safeguard scanners monitor the support burner and the waste fuel burner at all times when they are operational. The control system meets UL, IRI and FM Insurance requirements for safety.

These units are normally supplied as complete turn key projects with design, supervision of installation, start up and operator training provided by factory trained personnel.

Waste Fuels Burned:

Sanderdust
Sawdust
Particle Board Plant Fines
Wood Chips
Dry Bark (15% Moisture W.B.)
Peanut Hulls
Coffee Grounds
Spent Tea Leaves
Paper and Cardboard

Types of Installations:

- | | |
|---|---|
| I. In Combustion Chamber of boilers for the Wood Processing Industry. | 1. Firebox or HRT type Firetube Boiler.
2. Water Tube type Boiler. |
| II. Separate Furnace with Hot Gas Duct to Waste Heat Boilers. | 1. Horizontal Multiple pass Shell and Tube Boilers.
2. Water Tube type Boilers. |
| III. In Air Heaters as the Heat Source for Rotary Dryers. | 1. Particle Board Plants.
2. Wafer Board Plants.
3. Wood Pellet Plants.
4. Sugar Beet Pulp drying for Pelletizing. |

The SF Suspension Burner is a good method of burning waste fuels. It burns the fuel completely, the fuel can be stored easily and delivered to the boiler in accordance with the steam demand. There is a minimal amount of fuel in the chamber at any one time which improves control and

eliminates the over shooting when steam demand drops as compared to mass or pile burning on the grate.

The main disadvantage is the requirement for fuel preparation to reduce the particle size of the fuel, which adds capital equipment costs in the hoppers or hammermills required and in the electrical cost of operation. - However, in many cases a fair portion of the waste fuel is already in the "fine" state such as sander dust, sawdust, particle board fines etc. which will make the suspension burner a logical choice.

MUNICIPAL REFUSE BURNING

Two years ago PGP decided to extend their waste fuel burning capability to include municipal waste. Patent rights were purchased of a Rotary Grate type design - two stage incinerator called the "Pyrocone". A pilot plant of 25 TPD capacity had been installed in Grafton, Wisconsin and operated for 3 years. The plant incorporated a waste heat boiler but the steam was dissipated through a Fan-Coil heat exchanger on the roof. There was not a steam customer close by to utilize the steam. Economics indicated the plant be shut down due to a favourable land fill disposal contract approximately 6 years ago. In July 1982 PGP resumed operation of the plant on a one shift per day basis to train personnel and obtain operating data.

We are now planning to add a second Model 25 unit to the Grafton plant, install a higher pressure steam boiler (350 psig) and a condensing turbine to get income from the steam generated in the form of electricity to add to the tipping fees and improve the economics.

In addition a completely new 3 TPH (75 TPD) model has been designed using the same basic principals as the smaller unit but incorporating improvements learned over the years.

We have been working with several municipalities to install new plants. The interest level is very high as the new EPA requirements for land fill in the U.S. are stringent which greatly escalates the cost. Obtaining sites is also very difficult for new land fills, creating a strong incentive to burn wastes and preserve the life of existing land fills.

The main features of the Rotary Grate Furnace design are:

1. The RGF utilizes a two-stage incinerator design. Initial combustion occurs under starved air conditions within the rotating cone in the primary chamber. Combustion is then completed in the secondary chamber where additional air is added to the fuel-rich gases. The hot gases are then ducted to the waste heat boiler.
2. The tumbling action provided by the rotating cone permits all surfaces of the fuel particles to be exposed to combustion air. The refuse remains in the cone until it is consumed or the ash residue becomes small enough to drop through the grate openings down into the ash pit where it remains until cool enough to dump.
3. The ash which is left from the combustion process is essentially inert and represents approximately 5% of input volume. Since the ash is inert, water quenching and the resultant contaminated water problem are avoided. In addition, dry ash weighs less.
4. The refractory life of the unit is not effected since the solid wastes do not come in contact with refractory surfaces. Scoring and the dragging of material on the combustion chamber walls are avoided.

5. The cone design eliminates the need for a large quantity of waste to be in the chamber at any one time. This feature allows for more flexibility in controlling temperatures. Water sprays to prevent temperature excursions and dumpstacks to vent hot gases in case of temperature imbalances are not needed in the RGF system.
6. The Rotary Grate Furnace does not require a tipping floor for the raw waste. The infeed hopper features a low maintenance conveyor which continually supplies the RGF with waste material. Preparation of raw waste material is minimal. Separation and removal of large non-combustibles and material which will not fit into the large infeed chute hopper is necessary. The remaining waste may be fed directly into the system. Metal cans, glass containers, and similar sized non-combustibles do not require removal and do not interfere with the combustion process. A clean out plug is periodically retracted to remove non-combustibles which do not fall through the grates of the cone.
7. In case of repair, the unit is designed so access is available to the cone and interior chamber in a matter of 2 to 4 hours. The short cool down time is possible because of the small amount of waste in the unit at any one time. Access is made easy by a retractable assembly permitting the cone to be moved away from the chamber.
8. An auxiliary fuel burner is used for initial ignition of the infeed material. No additional fossil fuel is needed once combustion is sustained.

We are presently offering the Electrostatic Precipitator for the emission control of particulates. The ESP is necessary when requirements are as low as .08 grains/SDCF at 12% CO₂. The I.D. Fan, draft control and stack complete the major items of equipment down stream from the boiler.

The RGF is only offered as a complete system including engineering, erection, start up and an operator training period of one year. Most municipalities are requiring performance guarantees by the equipment manufacturer.

AUSTRALIA/UNIDO WORKSHOP:

WASTE HEAT RECOVERY IN INDUSTRIAL PROCESSES
29th FEBRUARY — 11th MARCH 1985 MELBOURNE

FLUIDISED BED COMBUSTION

Dr R.D. La Nauze
Fossil Fuels Division
C.S.I.R.O.

1. INTRODUCTION

There is general recognition that before the end of this century the demand for oil and gas will outstrip supply. As production of these fuels passes its peak and reserves become depleted, coal will return to its former dominant position. The change has already begun. To accelerate this change and to secure the full benefit of using coal, new industrial coal-burning systems are being developed.

In order to keep coal competitive and to meet exacting environmental requirements, fluidised combustion has been developed as a new coal combustion system. The requirements were that the system should be efficient, have low capital cost, be flexible in performance and in the type and quality of coal used, and also be environmentally acceptable.

The world wide interest in the fluidised combustion of coal over recent years has resulted in a wide range of development and demonstration units for a variety of applications. In Britain, America and West Germany, the introduction of fluidised bed combustion both in the power generation and the industrial sectors is considered an important aspect of their national energy objectives since it reduces demand for oil and gas as well as exploiting low grade or difficult coal reserves. In Australia significant developments are taking place to assess the potential for fluidised bed combustion under local conditions, in addition these applications include the use of fluidized beds for the combustion of industrial and agricultural wastes.

2. PRINCIPLES OF FLUIDISATION AND FLUIDISED COMBUSTION

2.1 Fluidisation

Solid particles can be moved by a fast stream of air or other gas. Imagine a box containing sand resting on a mesh. If air is blown very slowly upwards through the mesh, it percolates between the sand particles without disturbing them. When the velocity of the air stream is gradually increased, a point is reached when individual particles are forced upwards; they become supported by the air stream and begin to move about within a bed with a fairly well defined surface.

At still higher velocities an important change occurs; the bed becomes very turbulent with rapid mixing of the particles. Bubbles, similar to those in a briskly boiling liquid, pass through the bed and the surface

* Paper first presented Australian Institute of Energy; Melb. Group Meeting
23 July 1982

is no longer well defined. A bed of solid particles in this state is said to be 'fluidised', because it has not only the appearance but also some properties similar to a gas passing through a fluid.

There are lower and upper limits of air velocity between which satisfactory fluidisation of sand or any other granular substance will take place. The velocity of the air stream causing fluidisation is termed 'fluidising velocity'. For a bed of any material, the larger the particles, the greater the velocity of the air or other gas required to fluidise it; for particles of a given size, the heavier they are, the greater the fluidising velocity needs to be. Fluidising gas velocities between 1 to 3m/s are generally used.

In practice, a fluidised bed will contain particles of different sizes. The operating limits are set, on the one hand, by the minimum air velocity needed to keep the particles fluidised and, on the other hand, by the maximum velocity that can be used before an excessive quantity of material is blown out of the bed.

A fluidised bed of solids behaves in many ways like a liquid and has important characteristics:

- . The bed finds its own level. If the vessel containing the fluidised bed of solids is tilted from a horizontal position, the surface of the bed remains level.
- . Provided the fluidised state can be maintained, the bed can be transferred from one container to another as though it were a liquid.
- . Solid particles in a fluidised bed are violently churned about; rapid mixing occurs and any added particles are quickly distributed throughout the bed.
- . Objects can float or sink in a fluidised bed according to their density, as in a liquid.
- . When a fluidised bed is heated, the thorough mixing enables heat to be rapidly transferred from one part to another, ensuring near uniformity of temperature as in a liquid. This is in contrast to conditions in a bed of stationary particles, in which heat is transferred by the much slower process of conduction from one layer of particles to another. Temperature differences in beds of stationary particles can therefore be very high.
- . Mixing in a fluidised bed causes heat to be rapidly transferred to a cooler surface (for example, a water tube) immersed in it. The constant movement brings a continuous supply of hot particles to this surface.

2.2 Fluidised Combustion

The fluidisation principle has been successfully applied to combustion applications. The basic concept is that the fuel is supplied to a hot bed of particles (for example, coal ash or silica sand) and is fluidised by the upward passage of a stream of air. Because of the thorough mixing, the fuel is quickly distributed throughout the bed and is rapidly burnt, producing heat at a high rate for steam raising, water heating or other purposes. The temperature of the bed is uniform.

When feeding a material like coal, the ash remaining after combustion is removed continuously to keep the bed volume constant. Because of rapid mixing and the high rate of coal combustion, the amount of unburnt material in the bed is small; typically the bed will contain 0.5% to 1% of coal. For satisfactory operation the bed is kept below the temperature at which coal ash begins to fuse or sinter. The bed is therefore operated within the range 750°C - 950°C - the temperature at which a soft, fine ash is produced.

Control of the bed temperature within close limits presents no difficulty. Heat is transferred at a high rate from the bed to steam-raising or water tubes immersed in it; for good quality coals approximately half of the heat generated can be extracted in these tubes. This is an important feature requiring a smaller heating surface and bringing about a reduction in boiler size. A wide range of coal sizes (either lump or crushed coal) can be used. Coal size, the bed material and combustor dimensions depend on the application of the system; coal sizes are in the range 1 to 50mm with the bed material usually around 1mm in particle size.

The basic elements of an atmospheric pressure fluidised bed boiler are:

- water tubes within the bed
- convective tubes to recover heat from the off gases
- grit collector to remove fines from off gases
- combustion air preheater (optional)

These are shown in Fig. 1.

A fluidised bed boiler must be competitive with conventional methods of firing. The broad design requirements for an atmospheric pressure unit are:

- heat release rates of the order of $1 \times 10^6 \text{ W/m}^3$ of furnace volume are required
- bed temperatures must be limited to approximately half the adiabatic flame temperature or the ash softening temperature whichever is the lower
- excess air is to be limited to 10 to 20%
- this in turn requires that about 50% of the energy released by the fuel be removed by boiler tubes immersed in the bed
- the static depth of the bed is to be no greater than about 0.6m so that fan power consumption is not excessive

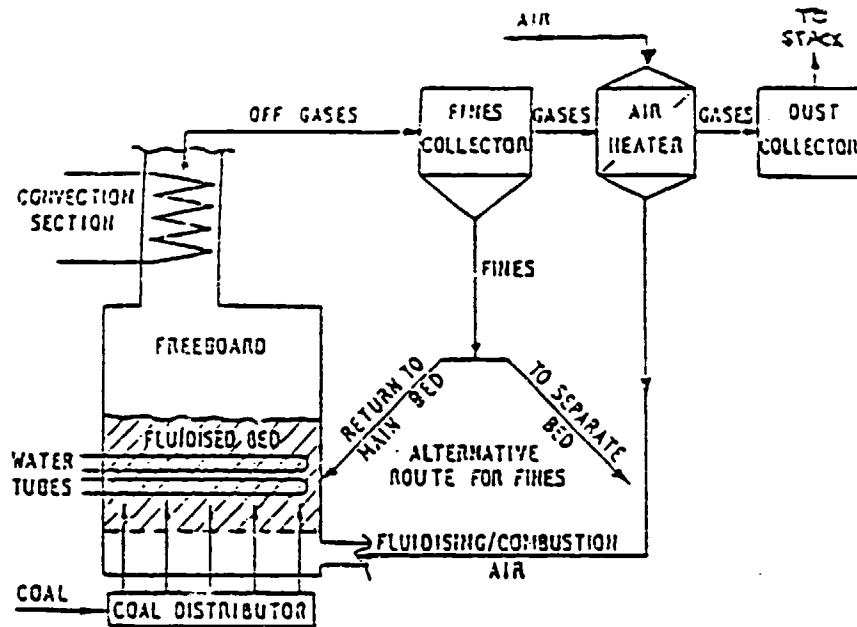

Fig. 1 An atmospheric pressure FBC boiler

The heat release rate is principally determined by the oxygen available in the fluidising air stream. Combustors operating at atmospheric pressure have been used generally for industrial boiler and waste incineration applications. By operating the combustor at an elevated pressure, much larger mass rates of oxygen can be achieved for the same fluidising air velocity and this results in much increased heat release rates per unit area of combustion bed. This effect of increased pressure is shown in Fig. 2. Power station applications of fluidised combustion have been based generally on pressurised systems where pressure energy would be recovered by passing the combustion gases through a gas turbine.

This combined cycle approach raises the electrical generating efficiency from about 38% to 42% thereby saving about 10% of fuel requirements.

At the low combustion temperatures, the formation of fouling materials is minimised or even avoided and the ash is not sintered into abrasive particles. The off gas from the combustor, after mechanical cleaning is generally clean enough to not foul or erode turbine blades.

Power generation with fluidised combustion offers considerable cost savings over conventional systems because of the reduction in size. The extent of the savings has been assessed recently (N.C.B. 1980) and is summarised in Table 1.

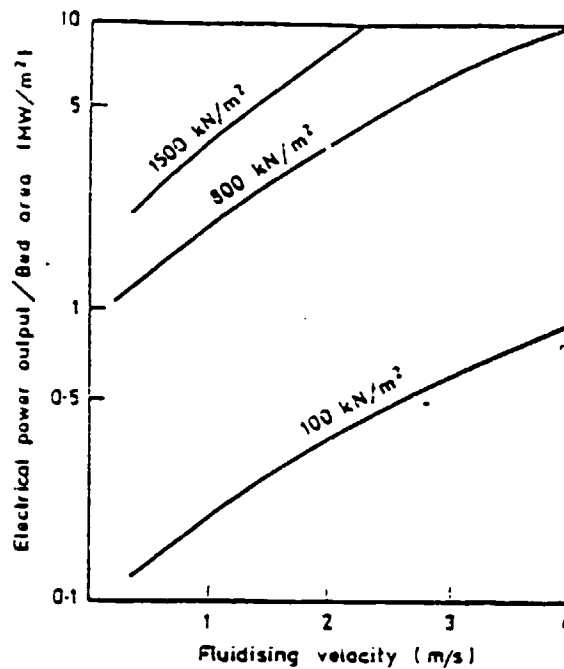

Fig. 2 Electrical power output/bed area for different system pressures, assuming 20 percent excess air, 38 percent cycle efficiency

Table I Costs of atmospheric and pressurised fluidised bed combustion of coal compared with pulverised fuel firing for electricity generation.

Fluidised bed combustion	% saving on capital cost of pulverised fuel station		% saving on operating costs of pulverised fuel station	
	With sulphur removal	Without sulphur removal	With sulphur removal	Without sulphur removal
Atmospheric	22	12	9	2
Pressurised	10	3	13	8

Explanatory Notes

1. Systems compared are: conventional pulverised fuel boiler with steam cycle, atmospheric fluidised bed boiler with steam cycle, and pressurised fluidised bed boiler with combined cycle.
2. Systems are compared for high sulphur coal (3.5%) with 35% sulphur removal and for a low sulphur coal without sulphur removal.
3. Capital costs are mid-1978 prices for 1000 MW (electricity) plant, assuming a 15% contingency allowance and a 10% architect/engineer fee.
4. Mid-1978 UK average coal cost = £0.92/GJ.
5. Operating costs consist of coal, sorbent, waste disposal, operating labour, maintenance and insurance.

2.3 Advantages of Fluidised Combustion

The fluidised bed combustion of coal has major advantages over other combustion systems:

- . The high rate at which heat can be transferred from the bed for steam raising or other purposes enables smaller (and cheaper) boilers and furnaces to be used.
- . Because the concentration of coal in the bed is small, combustion is hardly affected by coal type, ash or moisture contents. The burning coal is surrounded by inert material, so that there is little tendency for coal particles to stick together. For the same reason, coals of variable ash and moisture contents do not upset the process, in contrast to pulverised fuel firing where coal of fairly uniform properties and ash content is necessary. Low-grade fuels regarded in the past as unsuitable for combustion can be used in a fluidised bed combustor.
- . In contrast to pulverised fuel firing, fluidised bed combustors can use commercially available grades of coal without further treatment, in this way saving costs.
- . At high temperature, small amounts of certain salts are vaporised from coal ash; the higher the temperature, the more the amount vaporised. Salts emitted from hot ash in a boiler condense on steam or water tubes, causing gradual fouling. At a maximum of 950°C, the temperature in fluidised bed combustion is well below that in other systems (for example, over 1200°C in pulverised fuel firing). Emission of deposit-forming materials is therefore less than in other boilers and tube fouling is minimal.
- . Particle velocities are well below that at which steel is eroded by impact; scouring by the moving particles can be beneficial in preventing build-up of deposits on the pipes.
- . The evenness of the fluidised bed temperature enables automatic control to be more precise than in other coal-burning systems.
- . More efficient methods of generating electricity can be developed using coal-fired gas turbines.
- . The environmental contribution of fluidised bed combustion is significant. Low operating temperature in the bed helps to reduce, control and even eliminate emissions that may cause environmental concern (particularly oxides of nitrogen and sulphur). During conventional combustion at high temperature, oxides of nitrogen are formed from oxygen and nitrogen in the air; however, at the low temperature of fluidised combustion, this does not occur so readily. Oxides of nitrogen can also be formed from nitrogen in the coal, but the methods of operation of fluidised combustion minimise their emission.

Sulphur dioxide is formed from the sulphur in a burning fuel. At the low temperature of fluidised combustion, most of the sulphur dioxide can be prevented from passing into the atmosphere by adding materials such as limestone or dolomite, which react with the sulphur dioxide, fixing

it in a solid removed with the ash. This technique is economically and technically preferable to processes in which sulphur dioxide is washed from flue gas. Sulphur retention is particularly important in those countries such as the U.S.A. which possess large reserves of high sulphur coal. With the appropriate amount of limestone charged with the feed coal, very good sulphur removal can be achieved as shown in Fig. 3.

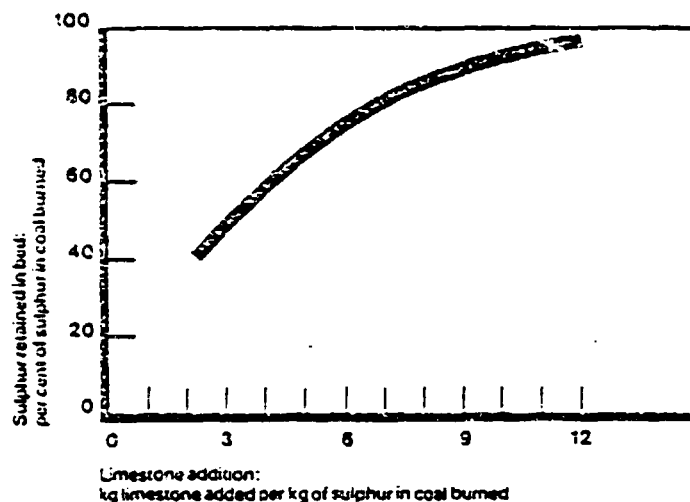

Fig. 3 Sulphur retention

3. RATES OF COMBUSTION IN F.B.C.

3.1 Bubble Mechanics

As all fluidised combustion applications require the use of air or oxygen as the fluidising medium, all of these systems operate in the aggregative mode of fluidisation where the bulk of the gas flows through the bed as bubbles. The rising velocity of a bubble in a static fluidised bed is given by:

$$U_b = 0.71 \sqrt{g D_b} \quad (1)$$

where D_b is the diameter of a sphere which has the same volume as the bubble.

When the bubbles are large and approach the container size, the bubbles become elongated slugs of gas. The rising velocity of a slug is determined by the container diameter and is given by:

$$U_b = 0.35 \sqrt{g D_c} \quad (2)$$

where D_c is the diameter of the containing vessel.

The above equations for a gas at negligible density can be modified when the gas density becomes significant when compared with the bed density.

Before considering the mechanics of combustion, the distinction must be made between "fast" and "slow" bubbles. From the two phase theory of fluidisation, the interstitial rising velocity of gas through the bed is

$$u_o / \epsilon_o$$

When the rising bubble velocity U_b is less than this interstitial gas velocity the bubble is described as "slow" and there is a free exchange of gas between the bubble and the bed. For "fast" bubbles the rising bubble velocity is greater than the interstitial velocity and under these conditions a cloud forms around the bubble severely restricting the exchange of gas between the bubble and the bed.

From bubble mechanics in a fluidised bed it can be shown (Davidson and Harrison, 1963) that the concentration of a gaseous reactant, eg. oxygen varies according to bed depth in the following manner:

$$c_b = c_p + (c_o - c_p) \exp(-Qy / u_A V) \quad (3)$$

where c_p is the gaseous concentration in the particulate phase and c_b is the gaseous concentration in the bubble phase.

The term $(Qy / u_A V)$ is the number of times the gas in the bubble has been flushed out by exchange with the bed during its rise to level y . When $y = H$ the bed height is then:

$$X = QH / u_A V \quad (4)$$

3.2 Char Combustion

Figure 4 indicates some of the parameters which must be determined in order to predict the rate of coal combustion in a fluidised bed. The heat release, carbon hold-up carbon elutriation and combustion efficiency can be derived from a knowledge of the combustion rate, the physical behaviour of the bed and the ash properties. Assumptions used for the development of models for char combustion vary but most assume "fast" bubbles, appropriate to bench-scale apparatus. The resistance to the transfer of gas from the bubble phase to the dense phase can be characterised from the two-phase theory by the prediction of the parameter, X of Eq. 4. This enables the prediction of the dense phase oxygen concentration. The concentration profiles are then obtained by solving the diffusion equation for the transfer of the gaseous species to and from the burning particle. The rate, R , and hence the heat released at the particle surface, may be obtained from the expression

$$R = 2\pi d^2 K c_p \quad (5)$$

where c_p is the oxygen concentration in the particulate phase, d is the particle size, and K the combined diffusional and kinetic resistances. The reaction rate of the carbon has been assumed first order with respect

to oxygen.

The expression for K takes the form:

$$\frac{1}{K} = \frac{\gamma}{k_c} + \frac{\alpha d}{Sh D_g} \quad (6)$$

where k_c is the chemical rate constant, Sh is the Sherwood number and D_g the diffusivity of oxygen. α and γ are constants which take the values indicated below.

The value of K depends on which of the following reactions is assumed at the particle surface:

		α	γ
(i)	$C + \frac{1}{2}O_2 \rightarrow CO$	1	2
(ii)	$C + O_2 \rightarrow CO_2$	2	2
(iii)	$C + CO_2 \rightarrow 2CO$	1	1

A pseudo-first order velocity constant, k , is defined by writing:

rate of O_2 consumption per unit volume = kc_p

from which the burnout time, t_c , for a batch of uniform particles is given by

$$t_c = \frac{m}{12c_o A (U - (U - U_o)) e^{-K}} + \frac{\rho_c d_i^2 \alpha}{96 Sh D_g c_o} + \frac{\rho_c d_i \gamma}{48 k_c c_o} \quad (7)$$

where c_o is the inlet oxygen concentration, and d_i the initial char particle diameter of density ρ_c . The first term represents the contribution to the burnout time of the batch charge, the second the diffusional resistance, and the third that due to the kinetic resistance at the particle surface. The magnitude of burnout time clearly depends on many parameters but is commonly in the range of 500 to 2000 s.

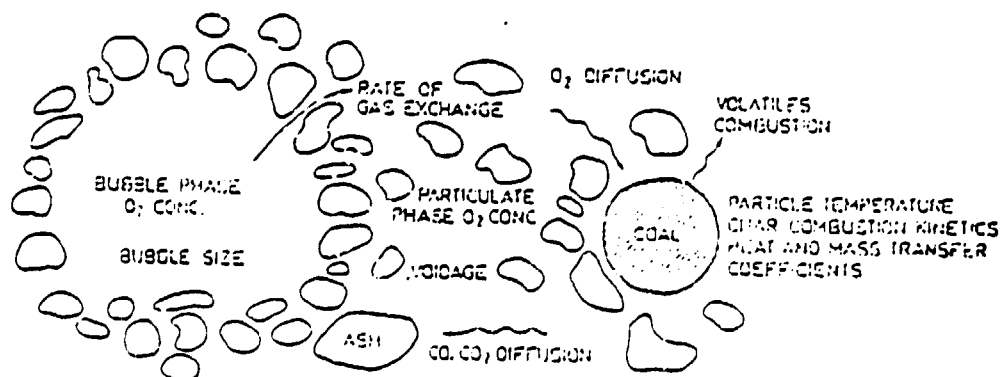

Fig. 4 A coal particle burning in a fluidised bed

A knowledge of the chemical kinetics is required in order to obtain values from Eq. 7. A severe limitation of experiments to date has been the lack of kinetic information about the char. Most have assumed literature correlations for prediction of the chemical rate constant.

While it may be shown that for particles $>5\text{mm}$ the rate of char combustion was predominantly controlled by the rate of transfer of oxygen from the bubbles to and through the particulate phase, other work indicates that for particles $<5\text{mm}$ both diffusion and chemical kinetics control the rate of combustion. The proportion of chemical kinetic control is dependent on both temperature and particle size as shown in Fig. 5.

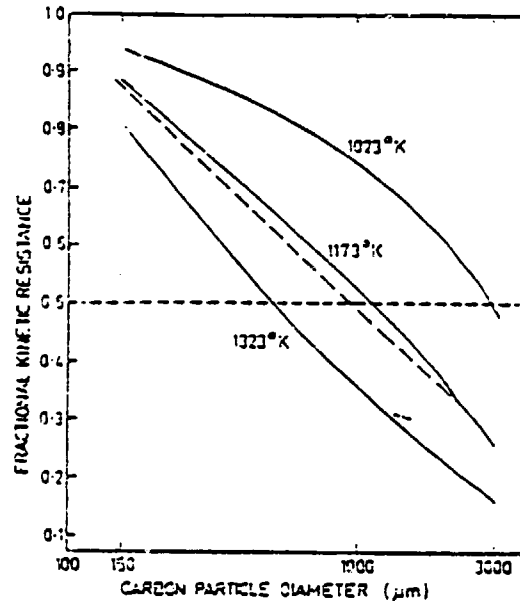

Fig. 5 The dependence of kinetic resistance to combustion on particle size (--- = experiment of Ross (1979) 5 to 10% O_2 ; — = calculations of Borghi et al (1977) 4% O_2)

Since for some coals more than half their heating value arises from volatile components which are released from the coal surface to consume oxygen in competition with the remaining char, it is important to consider volatiles combustion in a comprehensive fluidised combustion model. The significance of volatiles in the application of models to fluidised-bed combustors is well established and some fundamental work on this important aspect is now available.

In recent studies the volatiles are assumed to burn in a diffusion plume emanating from the coal entry port. Figure 6 shows the formulation of this model for a fluidised bed with two coal entry ports at the distributor level. The volatiles are assumed to diffuse radially as they pass through the bed, while the char particles become distributed throughout the bed. The rate of char combustion is assumed to be zero inside the plume, and takes place at the mean oxygen concentration outside these zones. The application of this approach to large-scale equipment needs to be fully assessed.

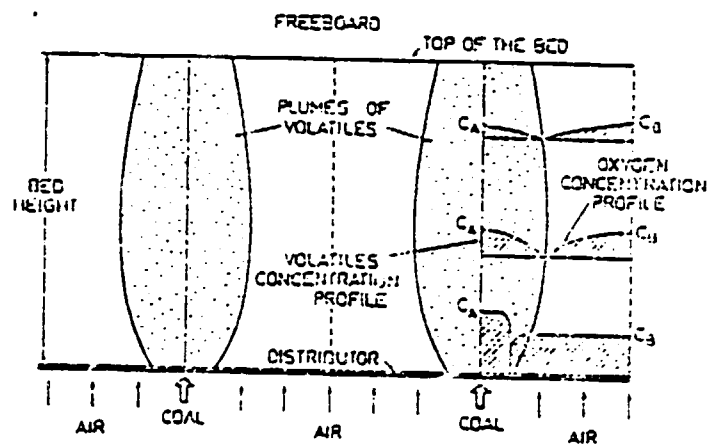

Fig. 6 Concentration profiles for volatiles (C_A) and oxygen in the vicinity of the volatile plumes (C_B) from two coals feed points near the distributor level in a fluidised-bed combustor (from Park et al, 1980)

4. REVIEW OF F.B.C. DEVELOPMENTS WORLD WIDE

4.1 Britain

For more than a decade Great Britain has accumulated a considerable body of experience in the fluidised combustion of coal. A 2.5 MW (thermal) vertical shell boiler and a 2 MW (thermal) pressurised combustor have been operated by the National Coal Board (NCB) since 1969 and 1970 respectively. A larger atmospheric pressure unit of 13.5 MW (thermal) has been operated by Combustion Systems Ltd and Babcock and Wilcox (UK) Ltd at Renfrew, Scotland since 1975.

Pioneering work carried out by the Central Electricity Generating Board and the NCB in the 1960s was directed toward the development of a new coal-fired power station. However, there was little incentive to pursue the advantages of fluidised combustion as oil was in plentiful supply and a vigorous nuclear program had been initiated. The oil crisis of 1975, which might have brought about a radical change in attitude to a coal-based technology, was accompanied by (a) a slowing in demand for electricity because of the economic situation, (b) energy conservation measures, (c) the introduction to the market of North Sea oil and gas and (d) a strategic decision to build a large pulverised-fuel-fired power station. As a consequence, electricity generating capacity in Britain is likely to meet the needs of the immediate future and there is little possibility for some time of local power generation using fluidised combustion. The British, however, were quick to realise the importance of using fluidised combustors for burning high sulphur coals by adding limestone to the bed. As a consequence their efforts in power generation have largely been directed toward overseas markets.

Locally the NCB predicts the largest growth in coal sales will be in the industrial sector and is encouraging the development of a range of fluidised bed boilers to meet consumers' needs in this area.

Industrial Boilers

Conventional coal-fired boilers are at a considerable disadvantage compared to oil-fired or gas-fired units, particularly in the costs of providing coal handling facilities and higher manning levels. Large industrial coal-fired boilers are also limited in that they can burn only a very narrow range of fuels. Fluidised bed boilers are being developed because they offer higher combustion intensities, more compact construction and greater amenity than conventional stokers.

The conversion of a cross-type stoker at Renfrew to fluidised bed firing was completed by Combustion Systems Ltd/Babcock and Wilcox (UK) Ltd in 1975. The boiler has provided steam for the factory at more than its rated output of 20,000kg/h steam. A variety of fuels have been burnt including high ash and high sulphur coals. As a result of these tests, the company is offering commercial guarantees for large industrial fluidised bed boilers.

A significant component of the cost of a boiler is the crushing equipment for pneumatic feeding of the coal. An important departure from pneumatic feeding has been developed at the Coal Research Establishment

of the NCB. In this development coal sized between 12mm and 25mm is screw fed above the bed surface. A succession of development plants (Table II) have been built on industrial premises. The largest of these is a 30 MW (thermal) high pressure steam boiler at the British Steel Works in Sheffield.

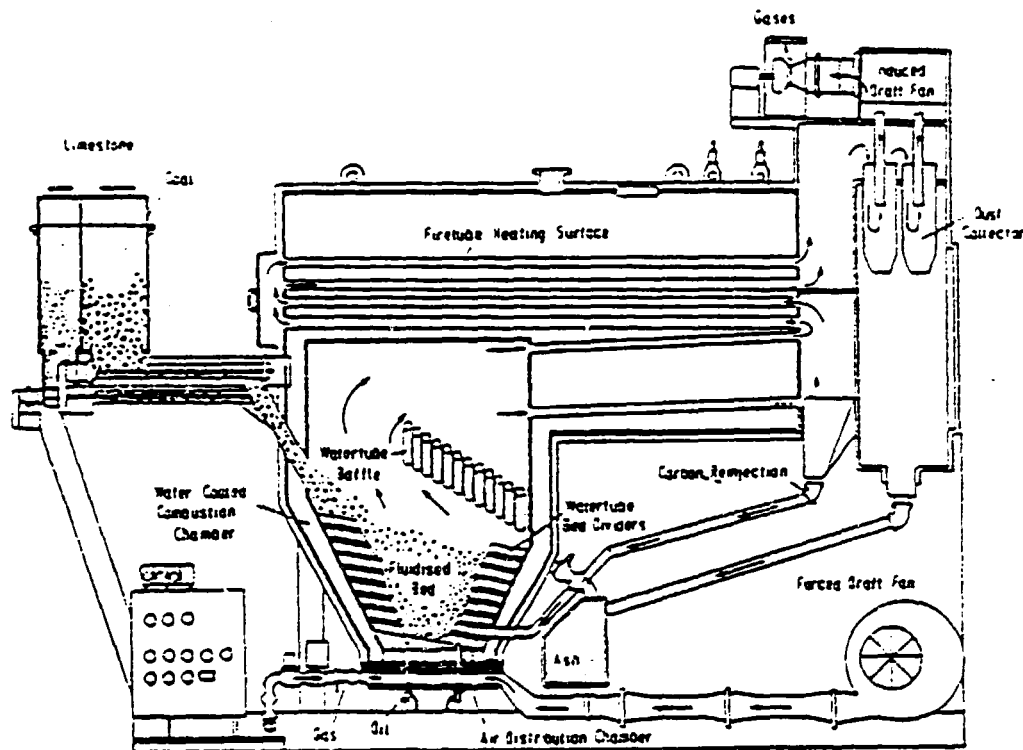

Fig. 7 Locomotive-type package fluidised bed boiler

The most popular boiler in Britain is the horizontal shell boiler. Although the NCB is attempting to adapt this to fluidised bed firing, the preferred designs have (i) vertical combustion chambers with vertical thermosyphon tubes to give water flow by natural circulation or (ii) vertical combustion chambers with horizontal convective sections - a locomotive type boiler arrangement such as illustrated in Fig. 7

A range of hot water and steam boilers is being marketed by Stone-Platt fluidfire which vary in concept from the above in several interesting ways. These boilers, are designed (i) to induce a circulation of solids in the combustion zone which (it is claimed) decreases the loss of coal by elutriation, (ii) to operate at a lower fluidising velocity, (iii) to screw feed the coal below the bed surface and (iv) with separate combustion and heat transfer zones within the furnace. Heat removal is controlled by individual air supply to each zone. The arrangement is illustrated in Fig. 8.

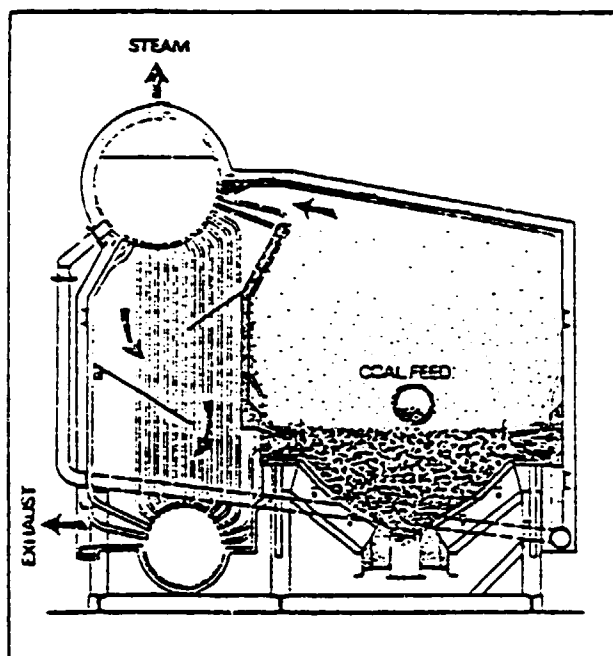

Fig. 8 Industrial fluidised bed boiler, Georgetown University, USA.

Power Generation

The developments in power generation applications are largely confined to the NCB and Babcock and Wilcox (UK) Ltd. These two groups together with the Swedish turbine manufacturer Stal Laval are studying a pressurised fluidised combustor system coupled to a 70 MW (electrical) gas turbine for the British Columbia Hydro Authority in Canada. The same team is linking through Coal Processing Consultants with American Electric Power to design and cost a combined cycle system to produce 170 MW (electrical).

In 1975 the NCB established a wholly owned subsidiary called NCB (IEA) services Ltd whose main task was to manage the International Energy agency's proposed pressurised combustor at the Grimethorpe Colliery in Yorkshire. This project is jointly supported by the Governments of Britain, America and the Federal Republic of Germany. The design capacity of the plant is 80 MW (thermal) operating at 6-12 bar at 800 to 950°C.

The plant, which is now operational, is described as a flexible experimental combustor rather than a demonstration plant.

4.2 U.S.A.

Interest in fluidised bed coal combustion in the U.S. dates from the same period as the European developments. Pioneering work in the 1960's by the consulting firm Pope, Evans and Robbins later led to the construction of what is currently the world's largest atmospheric

pressure plant at Rivesville, West Virginia. Only in the past few years, however, has there been intense activity and massive funding.

The main incentive for the development of fluidised combustion in the U.S. is the production of power from coal in an environmentally acceptable manner. A considerable proportion of coal reserves in America contains high sulphur or high alkali metal contents which in conventional methods of combustion lead to operating difficulties or high costs in providing flue-gas desulphurisation. Fluidised combustion offers the means of exploiting these difficult fuels without boiler fouling or stack gas scrubbing.

Industrial Boilers

Despite the major interest in power generation, the Americans appreciate that industrial boilers are a much nearer commercial proposition.

A 100,000lb/h boiler supplying steam at 275psig to the Georgetown University Central heating plant was built by Pope, Evans and Robbins/Foster Wheeler Energy Corp. in 1979. The design, Fig. 9 is for a bi-drum boiler with sloping tubes passing through the bed to allow natural circulation. Successful operation of the boiler has been reported.

The DOE has engaged Combustion Engineering Co to build two industrial boilers and Fluidyne Engineering Corp to develop an atmospheric hot air/hot water heater and distribution system. Exxon Research and Engineering Co. has DOE support to investigate potential application to refinery and petrochemical process heaters. As will be discussed by another speaker Dorr-Oliver is commissioning FBC boilers to burn anthracite culm.

Notable is the DOE support of Battelle Columbus Laboratories development of a second generation process termed multisolid fluidised bed combustion. This is a hybrid of the normal fluidised combustor and an entrained flow reactor. It has potential advantages in control/turndown and sulphur removal but is further from commercial realization.

The Ohio Energy and Resources Development Authority chose Babcock and Wilcox (UK) Ltd to retrofit a 60,000lb/h, 150psig saturated steam boiler at the Central Ohio Psychiatric Hospital in 1979.

The Johnston Boiler Co. of Michigan has recently launched a range of factory assembled industrial fluidised bed boilers (Fig. 7) with outputs from 2500 to 50,000lb/h steam up to 300psig. The aim of the company is to provide a multifuel boiler which is capable of oil or gas firing now and can in the future be easily and economically converted to coal firing when fuel prices or availability make this necessary.

Power Generation

It is not possible in the space to cover all the power generation projects. A quick glance at any recent fluidised combustion conference proceedings will give some idea of the numbers of groups involved. Many of the studies consist of detailed conceptual designs and costings which are based on limited operating data.

The DOE is sponsoring the 30 MW (electrical) atmospheric boiler at Rivesville. This was commissioned in 1977. The boiler consists of

three combustion cells which contain evaporative and superheater tubes in the bed. A fourth cell which contains no tubes in the bed acts as the combustion chamber for the elutriated fines from the other three cells. It is also used as the startup bed - the other cells being lit by transferring hot bed material from the fourth cell.

Although a great deal of experience has come out of this endeavor it has not been without operating troubles. The coal feeders, ash handling equipment, the air distributor and the electrostatic precipitator have all presented problems. However, the experience is providing many valuable insights into the operation of a large plant.

For pressurised applications the most significant operational pilot plants are the 1 MW (thermal) Exxon Miniplant at Linden, New Jersey, and the Combustion Power Co. 4 MW (thermal) unit at Menlo Park, California. A major concern in both projects is the assessment of the gaseous and solid constituents in the gas stream. Both groups are studying the performance of granular bed filters as a tertiary gas cleaning device and the corrosion of turbine alloys exposed to the off gases.

A 43 MW (thermal) pressurised unit incorporating a gas turbine has been commissioned by Curtiss-Wright under contract to the DOE. The design is based on an air heating cycle in which a proportion of the total air is heated in tubes passing through the bed. Recent NCB studies have shown severe corrosion of tube alloys at the high metal temperatures required for this cycle when limestone is present in the bed. These results may necessitate a reappraisal of the cycle adopted.

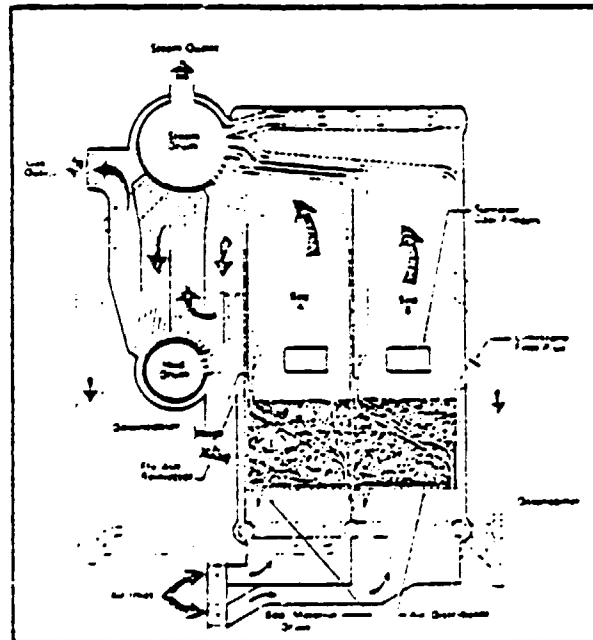

Fig. 9 Industrial fluidised bed boiler, Georgetown University, U.S.A.

4.3 Australia

Until quite recently there has not been the same degree of public awareness of the world energy situation in Australia as in Europe and the U.S.. Shielded by seemingly plentiful supplies of oil, gas and good quality coal there has not been the incentive to develop a novel method of combustion. Despite this, in the early stages of the overseas development of fluidised combustion, scientists at the CSIRO Division of Fossil Fuels demonstrated the advantages of fluidised combustion for the burning of low grade solid and liquid wastes. This effort has continued to the present day over a wide range of feedstocks.

Market pressures, caused by increasing oil prices and stable coal prices, will enable coal to compete in the Australian boiler market. Although owners of small packaged boilers may in some areas switch to gas this alternative may be relatively short lived and is not even an option in a great many places. A coal-fired stoker would be an alternative in this range but does not offer the ability to fire coal, oil and gas as available nor the possibility of unattended operation.

In the power generation sector it seems likely that coal from new fields in Victoria and South Australia will present difficulties when fired in pulverised fuel plants. There is a strong case to explore the potential of fluidised combustion to burn these coals without fouling or corrosion of boiler components.

In 1979 the National Energy Research Development and Demonstration Council commissioned a report to assess the needs for research into fluidised bed combustion in Australia. The principal findings of this report were:

Support for research, development and demonstration of fluidised bed combustion was needed by NERDDC on a significantly increased level so that it was at least commensurate with other promising developments in the energy field. Support would be justified from the potential benefits that fluidised bed combustion would bring to small and large industrial concerns and power generating authorities.

The priorities recommended for support were in order:

1. the demonstration of a coal fired fluidised bed combustion packaged boiler,
2. pilot plant studies leading to the demonstration of power generation by fluidised bed combustion especially for applications involving troublesome coals and coal wastes,
3. fundamental studies aimed at developing process understanding and plant improvements,
4. the development of a small to medium scale fluidised bed gas producer, and
5. the development of fluidised bed combustors for the utilisation of industrial, municipal and agricultural wastes and low grade fuels.

Fluidised bed combustion units in Australia are listed in Table IV.

Industrial Boilers

Although a number of groups are offering packaged fluidised bed boiler designs in Australia, to date no commercial unit has been installed to operate on coal. In 1980 NERDDC provided a grant of \$422,000 to the Health Commission of N.S.W./University of Sydney for the installation of a 3 MW steam boiler at Royal Prince Alfred Hospital, Sydney. This project is currently at the tendering stage with the expectation that the unit will be commissioned late 1982. This unit will provide, for the first time, a definitive assessment of the performance of a F.B.C. boiler using Australian coals.

Power Generation

Plentiful supplies of good quality coals in N.S.W. and Qld. allow relatively trouble free operation of pulverised fuel boilers but in Vic. and S.A. the coals burned in the power stations can cause excessive fouling. As a consequence these plants have heavy maintenance and down-time penalties. Both the State Electricity Commission of Victoria (SECV) and the Electricity Trust of South Australia (ETSA) are aware that fluidised combustion may have the potential to alleviate boiler fouling.

The SECV has recently built a 350 x 350mm atmospheric pressure pilot plant at the Herman Laboratories. The objective of the project is to investigate those peculiar difficulties which brown coal might present such as feeding and fouling. As any large plant would probably be designed by an overseas company on the basis of experience of burning foreign coals a knowledge of how the local coal burns in a fluidised bed is of paramount importance.

South Australia has large reserves of poor quality coals. The State will need to increase its coal-fired generating capacity by the mid-1980's and hopes to begin using a new coal field. The coal from the new field analyses roughly at 56 percent water, 2 percent sulphur and 7 percent ash with 14 percent sodium in the ash. ETSA has a collaborative program with the CSIRO Division of Fossil Fuels to perform combustion and fouling tests on this coal in the Division's 300 x 300mm fluidised bed combustor. It is probable that the first large scale application of fluidised combustion for power generation purposes in Australia will be for the use of difficult coals.

Other Applications

Australia produces quantities of waste material of moderate calorific value such as wood wastes, sugar-cane wastes, rice hulls and so on. A 1.2 x 0.9m fluidised bed incinerator, with heat recovery, was recently installed at an abattoir in Brisbane by Flameless Incinerators Pty Ltd. Garbage of a calorific value of 7.2MJ/kg has been treated at rates greater than 1 tonne/h. The Central Research Laboratories of BHP have also been examining the fluidised combustion of agricultural wastes.

The Joint Coal Board and the CSIRO Division of Fossil Fuels in collaboration with Cluska Development Ltd have been operating a 1.6 x 2.6m, 2 tonne/h, 4.5 MW (thermal) combustor at the Glenlee Coal Washery

The plant has burned both coarse reject material and thickened colliery tailings without auxiliary firing. Typical tailings feedstock consists of 60 percent water, 10 percent ash, 30 percent carbonaceous material. In this case fluidised combustion will not only be a means of overcoming an environmental problem but will enable heat to be extracted from otherwise unusable wastes. Installation of a waste heat boiler to this unit is expected to be completed by July, 1982.

Pyrecon Pty Ltd using the spouted fluidised bed technique developed in conjunction with the CSIRO Division of Fossil Fuels have been successfully marketing a fluidised bed incinerator - further details will be given in another paper to this seminar.

CONCLUSIONS

Fluidised bed combustors are available commercially. These are mainly incinerators, small packaged boilers and hot gas generators. As expected with a new development not all these plants have operated successfully. Trouble free operation depends not only on the suitability of the application but also on the design skills and experience of the group marketing the equipment. An understanding of both these aspects can only be gained by developing our own experience of fluidised combustion devices within Australia.

Fluidised bed boilers will soon be operating in Australia. These will be small boilers in the first instance burning coal and/or waste materials but, at a later date, large industrial boilers and atmospheric pressure power stations burning difficult or low grade coals seem a real possibility. It is unreasonable to expect pressurised fluidised bed combustion to be adopted for power generation until such time as there is a demonstrated method of obtaining gases of sufficient cleanliness to pass through a gas turbine.

For large scale applications, it will be necessary to demonstrate the combustion of the fuel in pilot plants of a realistic size and in tests of sufficient duration to produce meaningful design information. The development costs required for an understanding of how Australia's indigenous coals behave are small compared with the benefit accrued from strengthening coal's position in the heat and power markets, thereby releasing oil and gas for more critical uses.

NOMENCLATURE

A	bed cross sectional area
c_b	concentration of gaseous reactant (oxygen) in the bubble phase
c_0	concentration of gaseous reactant in inlet gas stream to bed
c_p	concentration of gaseous reactant in the interstitial gas in the particulate phase
D_c	diameter of the bed containing vessel
D_e	diameter of the sphere which has the same volume as the bubble
D_g	diffusivity of gaseous reactant (oxygen)
d	particle diameter
d_i	initial particle diameter
g	acceleration due to gravity
K	combined diffusional and kinetic resistances
k_c	chemical rate constant
m	batch charge weight
Q	effective rate of cross flow of gas between the bubble and particulate phases
R	rate of combustion
Sh	Sherwood number
τ_c	particle burnout time
U	fluidising gas velocity
U_b	bubble velocity relative to the particulate phase
U_0	superficial gas velocity of incipient fluidisation
u_b	absolute bubble velocity
V	bubble volume
x	number of times a bubble exchanges its volume with the particulate phase during its passage of the bed
y	height in the bed
α	constant defined in Eq. 6
δ	constant defined in Eq. 6
ϵ_0	voidage of particulate phase at incipient fluidisation
ρ_c	particle density

Bibliography

1. Proceedings of the 4th (5th, 6th and 7th) International Conference on Fluidized Bed Combustion. Held in the USA 1975 (1977, 1980, 1982).
2. Institute of Fuel Symp Ser No 1. Fluidised Combustion (London), 1975.
3. Institute of Energy Symp Ser No 4. Fluidised Combustion Systems and Applications, London , 1980.
4. Fluidized Combustion Conference. Energy Research Institute. University of Cape Town 1981.
5. Proceedings 1st (2nd, 3rd, 4th) Engineering Foundation Conference on Fluidization 1975 (1978, 1980, 1983).
6. Davidson, J.F. and Harrison, D. (Ed). Fluidization Academic Press, London, 1971.
7. Kunit D. and Levenspiel O. Fluidization Engineering. John Wiley & Sons, New York 1969.

84.01.04
AD.85.0
III I 5 5

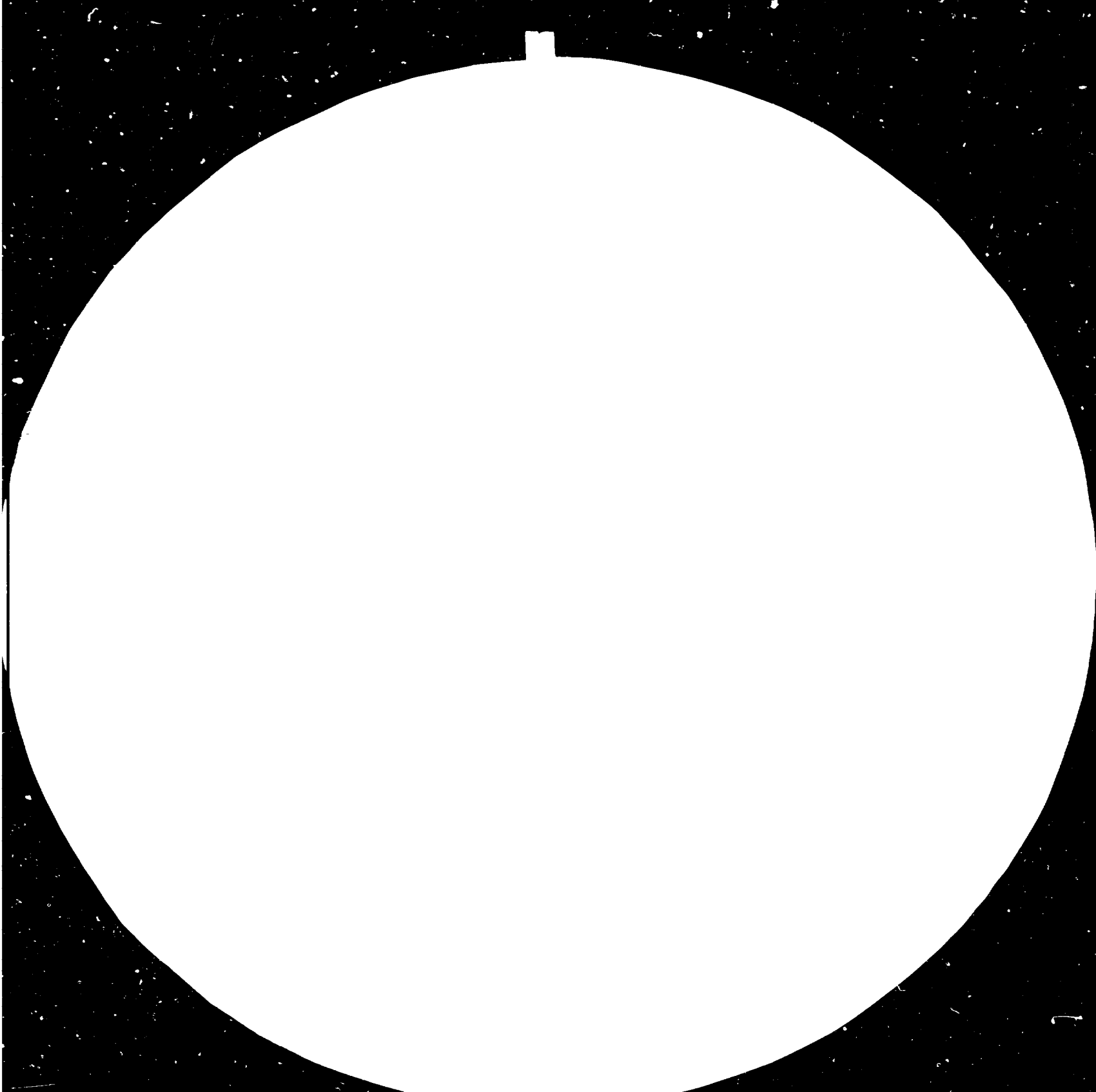

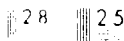

MEASUREMENT OF RESOLUTION, FIELD OF VIEW,
AND DEPTH OF FOCUS OF OPTICAL SYSTEMS

AUSTRALIA/UNIDO WORKSHOP:

WASTE HEAT RECOVERY IN INDUSTRIAL PROCESSES
28th FEBRUARY — 11th MARCH 1983 MELBOURNE

BIOGAS UTILISATION

McCain Foods
Ballarat Victoria

Bibliography

1. Proceedings of the 4th (5th, 6th and 7th) International Conference on Fluidized Bed Combustion. Held in the USA 1975 (1977, 1978, 1982).
2. Institute of Fuel Symp Ser No 1. Fluidised Combustion (London), 1975.
3. Institute of Energy Symp Ser No 4. Fluidised Combustion Systems and Applications, London, 1980.
4. Fluidized Combustion Conference. Energy Research Institute. University of Newcastle Town 1981.
5. Proceedings 1st (2nd, 3rd, 4th) Engineering Foundation Conference on Fluidization 1975 (1976, 1978, 1983).
6. Davidson, J.F. and Harrison, G. (Ed). Fluidization Academic Press, London, 1971.
7. Kunii D. and Levenspiel O. Fluidization Engineering. John Wiley & Sons, New York 1974.

BIOGAS UTILIZATION

Industrial Demonstration
Project at
McCain Foods, Ballarat.

A joint project of the National Energy Research, Development
and Demonstration Council, Gas and Fuel Corporation of Victoria
and McCain Foods (Aust).

Introduction

For many years, pilot plants have experimented with biogas production and combustion. To actually use it in a cost effective industrial situation is a different story. In its novel method of biogas utilization, the McCain project is unique, certainly in Australia.

There are wider ramifications of the success of the project. For those industries producing biodegradable wastes, the food industry in particular, it can now be demonstrated that the disposal of those wastes can be achieved in a manner acceptable to environmental authorities, and in such a way that energy consumption can be reduced and significant highly cost effective savings made. Future projects of this type will show investment payback periods of less than 2 years.

The McCain factory has been producing biogas from its anaerobic digesters for 2 years. This method was originally chosen to allow liquid wastes from the plant's

processes to conform to environmental authority trade waste requirements. Until now the biogas has been disposed of by flaring to atmosphere.

To use the biogas in the plant's boilers presented several difficulties. The biogas is impure, containing variable amounts of carbon dioxide and water vapour; its rate of production is also extremely variable. To overcome these problems a unique method was proposed to blend digester gas with natural gas and to use the resultant "shandy" to fuel the boiler. The system with its associated safety interlocks will guarantee reliable and safe boiler operation.

The project was a joint effort of the Gas and Fuel Corporation's Energy Management Centre and Scientific Services Department. Funding of the project was provided by an Australian Government NERDDC Research and Development Grant of \$45,000. Initial testing indicates that these funds have been very wisely invested, with savings in natural gas in the order of \$18,000 per annum.

The Company

McCain Foods (Aust.), a subsidiary of McCain Foods Ltd. of Canada, initially commenced its operations in 1971 at Daylesford, shifting to Ballarat in 1975.

The company is a focal point for the rich potato producing districts around Ballarat, processing many thousands of tonnes of potatoes annually. Although potato products continue to form the basis of its operation, McCain has diversified its activities into other areas of the food industry and now produces dim sims, pizzas, quiches and other entrees.

McCain is a vigorous, expanding company and is at present planning to further extend its operations.

More than 300 people are employed at McCain, making it a vital part of the economy of the Ballarat region.

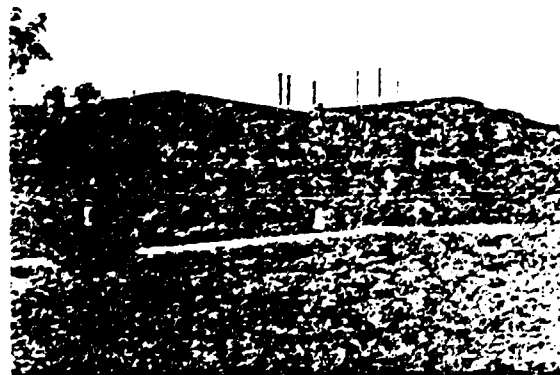

McCain Chip Plant — Ballarat, Victoria

Technical Summary and Systems Components

Biogas Properties

	Typical Range	
Composition (by volume)	CH ₄	45% - 80%
	CO ₂	55% - 20%
Higher heating value MJ m ³	17	30
Specific Gravity (Air = 1)	1.1	0.75

To accommodate future increases in factory production the system has been designed to handle double the present maximum biogas production rate of 100m³ hr.

Water Separators (7)

The biogas leaves the digesters at 35°C and is saturated with water vapour. Condensate formed in the pipe line as the gas cools, is removed by a water separator installed upstream of the flame trap and booster. The separator also removes any sediment that may leave the digesters. An additional water separator installed immediately before the boiler valve train, and strategically placed drain points deal with any further condensation.

Biogas Booster (1)

The function of the booster is to supply biogas to the boiler valve train at a pressure sufficient to ensure all biogas is fired in the boiler. The booster is direct driven by a flame proof electric motor and connected to the gas line by flexible couplings. It is capable of producing gas pressures to 13 kPa which ensures that back flow of biogas to the natural gas line past the boiler valve train will not occur.

A low gas pressure switch (10) at the booster inlet is set to shut down the booster and close the safety shut off valve if inlet biogas pressure falls below 0.5 kPa. A three way valve incorporated with the switch ensures automatic proving of the pressure switch on start up.

A second low pressure switch at its outlet proves booster operation. If outlet pressure falls below 6.5 kPa, the biogas safety shut off valve will close.

The biogas fan booster, primary liquid separator and associated controls.

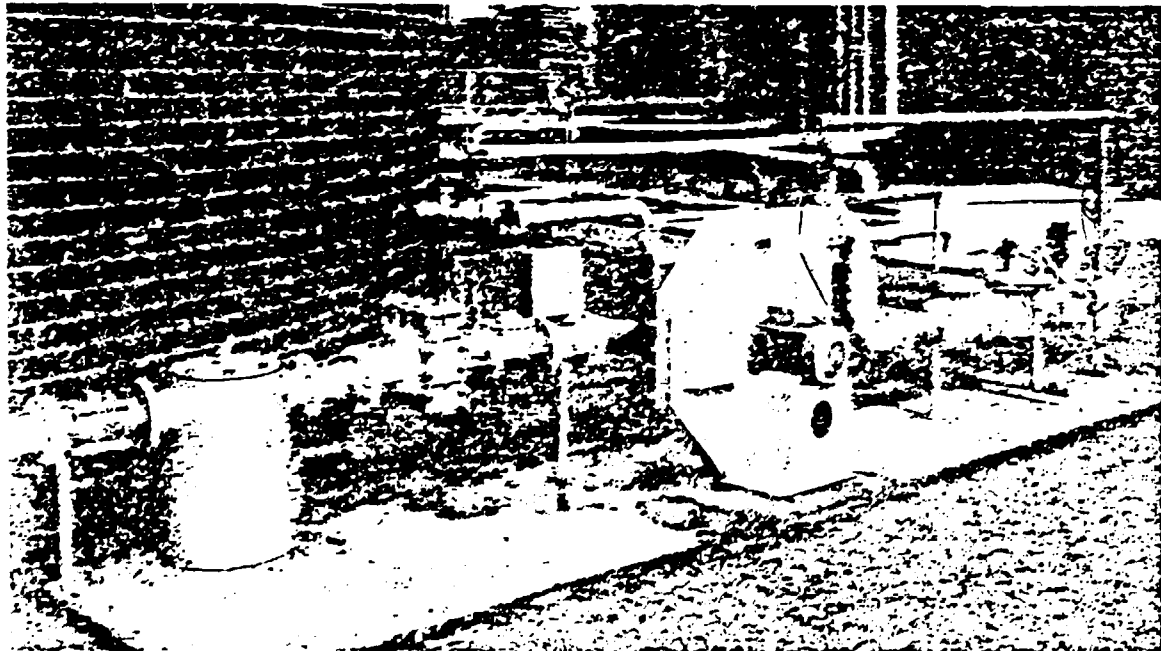

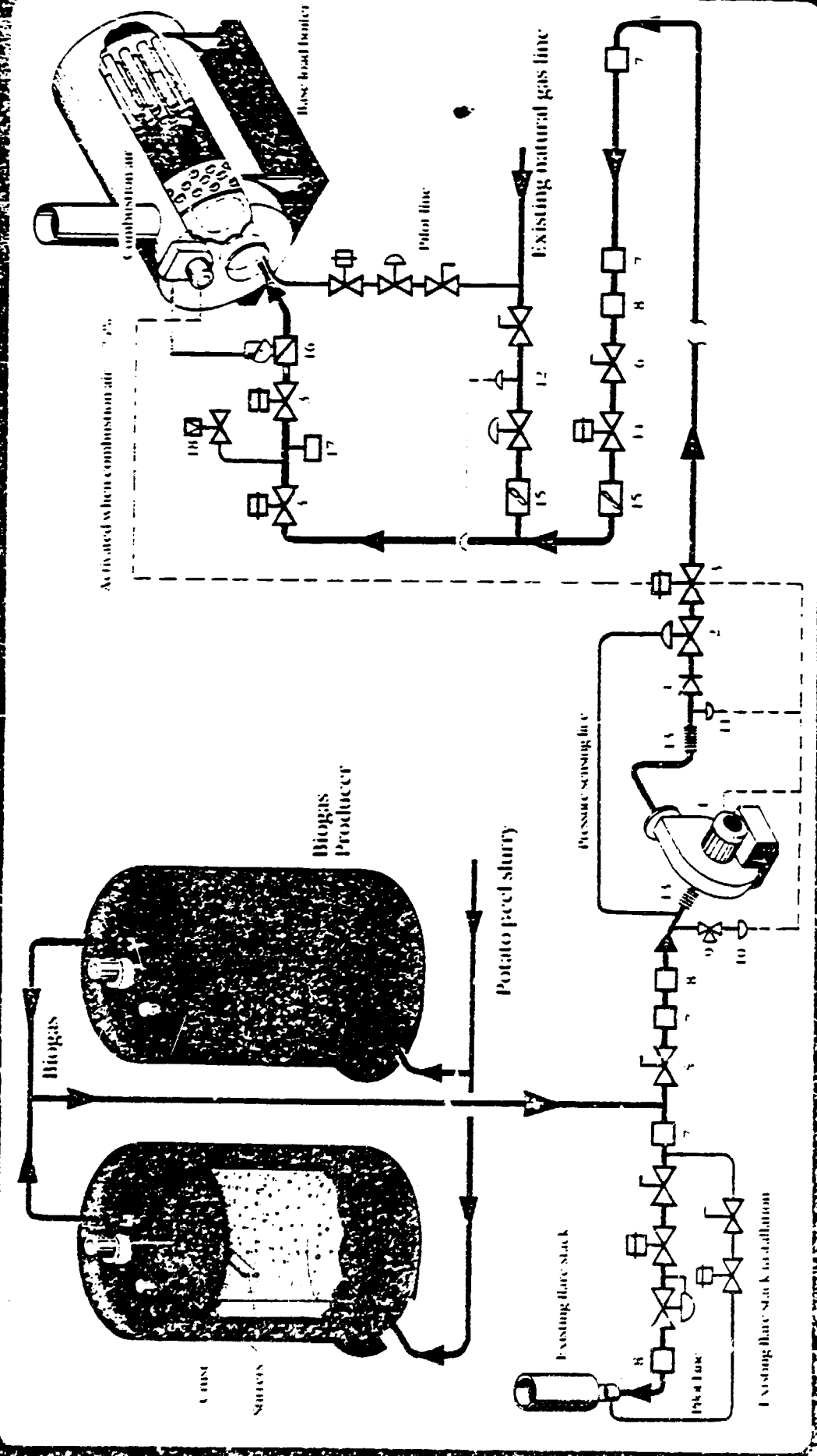

- 1 Gas/water tap
- 2 Flow control valve
- 3 Safety shut off valve
- 4 Non return valve
- 5 Manual gas valve
- 6 Manual gas valve
- 7 Water separator
- 8 Flame trap
- 9 Three way vent valve
- 10 Low gas pressure switch
- 11 Low gas pressure switch
- 12 Low gas pressure switch
- 13 Flexible coupling
- 14 Security automatic shut off valve
- 15 Gas meter
- 16 Motorized gas valve
- 17 Pressure proving system
- 18 Vent valve

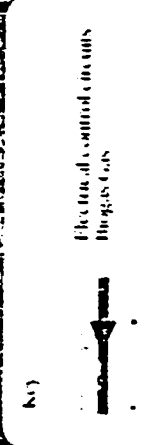

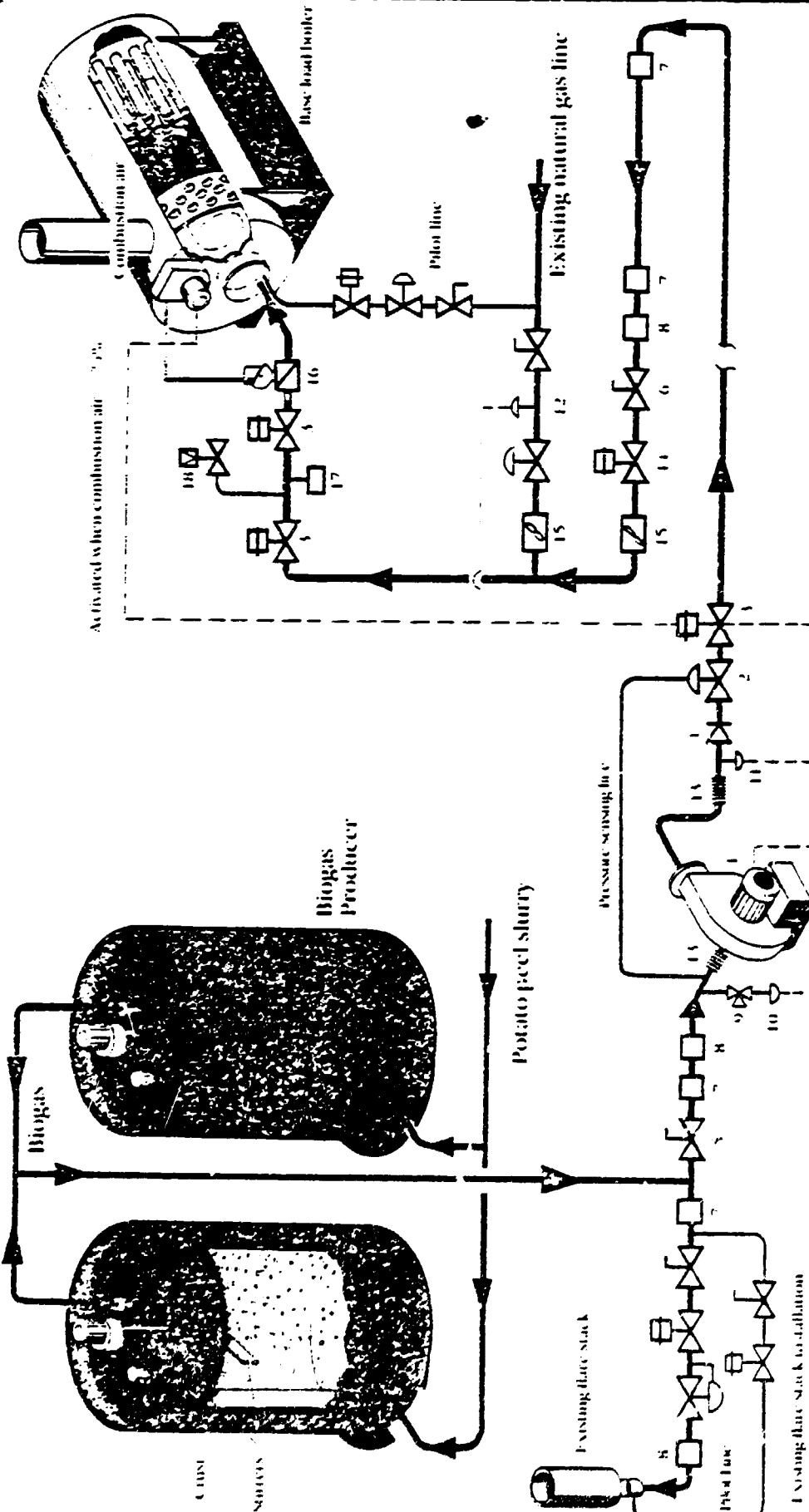

1 Aiming three stack to station

- 1 Gas blowoff fan
- 2 Flow control valve
- 3 Safety shut off valve
- 4 Non return valve
- 5 Manual gas valve
- 6 Manual gas valve
- 7 Valve separation
- 8 Flame trap
- 9 Three way vent valve
- 10 Low gas pressure switch
- 11 Low gas pressure switch
- 12 Low gas pressure switch
- 13 Flexible coupling
- 14 Security automatic shut off valve
- 15 Gas meter
- 16 Motorized gas valve
- 17 Pressure proving system
- 18 Vent valve

(b)

Electrically controlled circuits
Hobas Co's

Biogas Flow Control Valve (2)

This valve senses booster inlet pressure and closes if biogas pressure falls below 1 kPa and starts to open if biogas production recovers sufficiently to raise the gas pressure above this valve. The functions of the valve are:

- a) To ensure booster output matches digester biogas output.
- b) To prevent creation of a vacuum in the digesters, which could cause air ingress.
- c) To maintain constant booster inlet pressure close to 1 kPa.
- d) To prevent on/off cycling by the booster.

Biogas Safety Shut-off Valve (5)

This shut-off valve is installed immediately below the biogas control valve. It will interrupt the supply of biogas to the baseload boiler for any of the following reasons:

- a) Baseload boiler shut down.
- b) If the boiler fuel control valve drops below 75% full open setting.
- c) Booster inlet pressure drops below 0.5 kPa.
- d) Booster outlet pressure drops below 6.5 kPa.
- e) Inlet natural gas pressure to the boiler pressure regulator drops below 30 kPa.

There are further safety features in the system including flame trap assemblies, low pressure switches, automatic pressure proving procedures and so on — all of which are designed to ensure reliable and safe operation of the system.

Existing waste gas pipe and the flare stack. Previously all gas generated was conveyed to the flare stack and burnt to atmosphere.

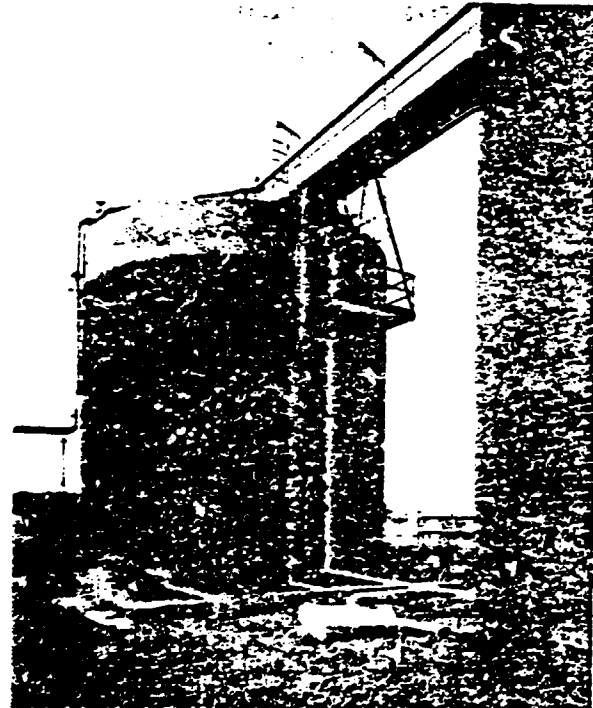

Biogas Digesters. The two digesters shown produce up to 2000 cubic metres of gas per day.

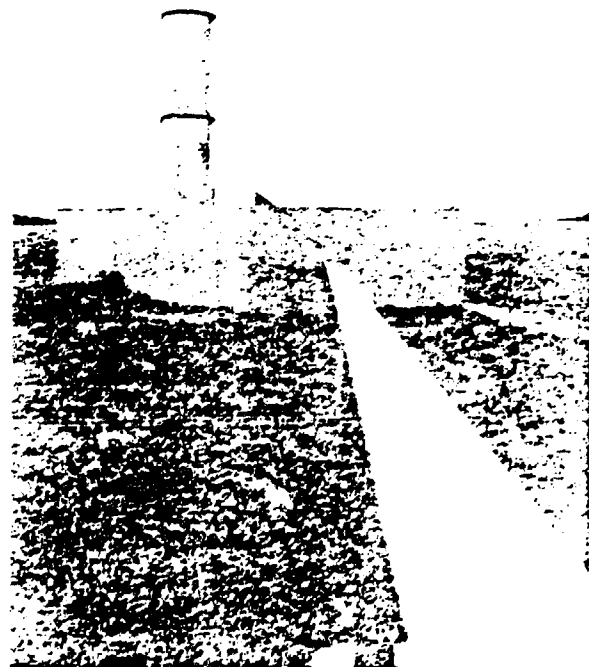

The Project

Economic Analysis

Present Biogas Production Rate	2000m ³ day
Biogas Energy Rate	50 GJ day (10% of daily N.G. usage)
Equivalent N.G. Cost Savings	\$75 day or \$18,000 year
Installation cost (Neglecting demonstration and experimental aspects)	\$30,000
Simple Payback period	1.7 years
System is designed to handle	4000m ³ day
(At this design rate the pay back period computes to less than 1 year)	

Operation of the System

The biogas installation may be divided into four main components:

- i) Potato waste digesters.
- ii) Excess biogas flare stack.
- iii) Biogas booster, flow controller and safety shut off valve assembly.
- iv) Natural gas fired baseload boiler (3.9 MW) and gas burner valve train.

Of these components i) and ii) were already in existence. In order to burn the biogas in the boiler the gas booster and flow controller were added. Modifications to the flare stack and boiler valve train were also necessary.

Biogas pressure at the digester is 2 kPa. The gas booster was required to overcome flow resistance as well as to raise the biogas pressure sufficiently to allow its introduction into the existing boiler valve train which operates at a natural gas pressure of 6 kPa.

On operation, biogas is fed into the valve train, mixing with natural gas before boiler firing. The system operates such that:

1. Booster flow rate always matches the digester output.
2. Biogas supply pressure into the boiler valve train is such that all available biogas will flow to the boiler.
3. The maximum variation of the heating value of the mixed gas does not exceed 25% of the pure natural gas value.

4. Automatic shut down of the biogas utilization system occurs if any of the safety requirements are not met.

Biogas is diverted to the flare stack when not required for boiler firing or on automatic shut down.



Burner and control equipment
Maximum boiler showing biogas pipe
fed into existing Natural Gas valve train

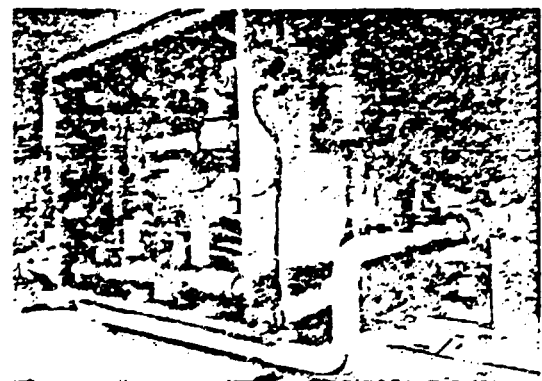

Control and metering equipment for biogas feed to the boiler

AUSTRALIA/UNIDO WORKSHOP:

WASTE HEAT RECOVERY IN INDUSTRIAL PROCESSES
28th FEBRUARY — 11th MARCH 1983 MELBOURNE

ATTACHMENTS

Overseas Participants

Australian Industry Participants

Workshop Officials

Program

AUSTRALIA/UNIDO WORKSHOP:

WASTE HEAT RECOVERY IN INDUSTRIAL PROCESSES
28th FEBRUARY — 11th MARCH 1983 MELBOURNE

OVERSEAS PARTICIPANTS

BANGLADESH

DR. DELWAR HOSSAIN
Additional Chief Metallurgist or Deputy General Manager,
Bangladesh Machine Tools Factory, Ghazepur,
Joydebpur,
DHAKA, BANGLADESH

ABOUL MANNAN
Deputy Chief Engineer (Power),
Khulna Newsprint Mills (BCIC),
KHULNA. BANGLADESH

MOHAMMAD NAZIM
Chemical Engineer
Bangladesh Chemical Industries Corporation,
Shilpa Bhaben, Motijhed C/A,
DHAKA. BANGLADESH.

BURMA

U WANN HLAING
Superintending Engineer,
Electric Power Corporation,
Ywama Power Station, Insein,
RANGOON. BURMA.

U TIN TUN
Divisional Inspector of Boilers,
Directorate of Regional Industrial Co-ordination and Industrial Inspection,
RANGOON. BURMA

INDIA

R.N. SINGH,
Additional Industrial Advisor,
Ministry of Industry,
Government of India,
Udyog Bhawan, Room No. 479,
NEW DELHI. INDIA

S. NAMMALVAR
Chemical Engineer.
Energy Cell I/C,
M/s Hindustan Antibiotics Ltd., PIMRI
PUNE. 411018. INDIA

INDIA (Cont'd....)

BASUDEV CHATTERJEE
M/S Hindustan Fertiliser Corporation of India Ltd.,
55 Nehru Place,
NEW DELHI.
PIN 110019. INDIA

INDONESIA

KURNIA HANAFIAH
Chemical Engineer,
Institute for R. & D. of Chemical Industry,
KARANG ANYAR 55,
JAKARTA. INDONESIA

PAKISTAN

DR. NISAR AHMAD,
Officer-in-Charge,
Solid Fuels Research Division,
P.C.S.I.R., D-102 South Avenue,
KARACHI 16,
PAKISTAN

GHULAM MURTAZA
Acting General Manager,
Zealpak Cement Factory Ltd.,
HYDERABAD. PAKISTAN.

PAPUA NEW GUINEA

PORLIN JAMES POPOT
Production Maintenance Supervisor (Mechanical Engineer),
ACI - New Guinea Containers Pty. Ltd.,
P.O. Box 613, Speybank Street,
LAE. MOROBE PROVINCE.
PAPUA NEW GUINEA.

SINGAPORE

CHONG THEAN CHONG
Senior Chemical Engineer,
Singapore Institute of Standards and Industrial Research,
179 River Valley Road,
SINGAPORE. 0617.

SINGAPORE (Cont'd....)

TAN SING ONG
Senior Principal Electrical Engineer,
Jurong Town Corporation,
Jurong Town Hall,
JURONG.
SINGAPORE. 2260

MR. ANG KOO SOON
Engineer/Edd,
National Iron and Steel Mills Ltd.,
22 Tanjong Kling Road,
Jurong Town
SINGAPORE. 2262

SRI LANKA

DON BARATHARATNA JAYANTHA RANATUNGA
Principal Research Engineer,
National Engineering Research and Development Centre,
EKALA, JAELA
SRI LANKA

THAILAND

DR. BUNDIT FUNGTAMMASAN
Faculty of Engineering,
King Mongkut's Institute of Technology, North Bangkok Campus,
BANGSON,
THAILAND.

AUSTRALIA/UNIDO WORKSHOP:

WASTE HEAT RECOVERY IN INDUSTRIAL PROCESSES
28th FEBRUARY — 11th MARCH 1983 MELBOURNE

INDUSTRY PARTICIPANTS

GAS & FUEL CORPORATION OF VICTORIA

Mr M.J. Shaw, Assistant General Manager
Mr K. Doyle, Group Manager, Marketing
Mr D.J. Alder, Chief Engineer
Mr K.J. Westall, Engineer in Charge, Energy Management Centre
Mr L.M. Adams, Engineer, Consultancy Services

SOUTH AUSTRALIAN GAS COMPANY

Mr A. Smithson, Manager, Industrial Gas Division

MELBOURNE & METROPOLITAN BOARD OF WORKS

Mr N. Sutherland, Mr G. Archer

AUSTRALIAN PAPER MILLS

Mr A. Campbell, Engineering Manager
Mr G. Gough, Manufacturing Manager

STATE ELECTRICITY COMMISSION OF VICTORIA

Mr G. Pollard, Engineer in Charge
Mr R. Whitburn

GILBERT & CHANDLER INSTITUTE OF DAIRY TECHNOLOGY

Mr G. Cox, Chemical Engineer

COMMONWEALTH SCIENTIFIC & INDUSTRIAL RESEARCH ORGANISATION

Dr R.D. La Nauze, Fossil Fuels Division

SMORGON CONSOLIDATED INDUSTRIES

Mr P. Krasnostein, Director

ICI AUSTRALIA OPERATION PTY LTD

Mr C.W. Peterson, Corporate Energy Manager

PETROLEUM REFINERIES AUSTRALIA

Mr K.W. Davies, Energy Conservation Co-ordinator

PEABODY GORDON-PIATT

Mr K. Gordon

MCCAIN FOODS

PRESHA ENGINEERING (AUST) PTY LTD

Mr J.C. Wrigglesworth, Managing Director
Mr J.E. Wilkie, Technical Director
Mr M.J. Salmon, Service Manager
Mr W.R. McLeod, Works Manager

AUSTRALIA/UNIDO WORKSHOP:

WASTE HEAT RECOVERY IN INDUSTRIAL PROCESSES
28th FEBRUARY — 11th MARCH 1983 MELBOURNE

WORKSHOP OFFICIALS

CHAIRMAN: Mr M.J. Cullen
M.J. Cullen & Associates

UNIDO REPRESENTATIVE: Mr G. Komissarov
Head, Industrial Energy
Engineering Unit

DEPARTMENT OF INDUSTRY AND COMMERCE:

Mr R. Bolduan
Director
Melbourne Regional Office

Mr L. Ffrench
Assistant Director
Multilateral Affairs Section
Canberra

Mr T. Robinson
Melbourne Regional Office

202

AUSTRALIA/UNIDO WORKSHOP:

WASTE HEAT RECOVERY IN INDUSTRIAL PROCESSES
28th FEBRUARY — 11th MARCH 1983 MELBOURNE

WORKSHOP PROGRAM

AUSTRALIA/UNIDO WORKSHOP:

WASTE HEAT RECOVERY IN INDUSTRIAL PROCESSES
28th FEBRUARY — 11th MARCH 1983 MELBOURNE

DAY 1 - SUNDAY, 27TH FEBRUARY, 1983

PM Arrival of Delegates and Representatives

VENUE: Sheraton Hotel,
 Spring Street,
 MELBOURNE.

DAY 2 - MONDAY, 28TH FEBRUARY, 1983

- 9.00 AM Registration and Administration Arrangements
Election of Chairman
- 10.00 AM Welcome - Mr. John Wrigglesworth
Official Opening - Mr. D.J. Fraser,
First Assistant Secretary,
Industry Division, No. 2
Department of Industry and Commerce
CANBERRA.
- 10.45 AM Introductory UNIDO Message - Mr. G. Komissarov
- 11.00 AM MORNING TEA
- 11.30 AM Introduction of Delegates - Chairman
Rationale and Objectives of the Workshop - Chairman
- 11.45 AM Paper on Behalf of UNIDO - Mr. G. Komissarov
- 12.00 PM LUNCH
(Own arrangements)
- 1.10 PM Assemble in Hotel foyer
- 1.15 PM Bus departs Sheraton for visit to -
Melbourne and Metropolitan Board of Works,
South Eastern Purification Plant,
Thompson Road,
CARRUM
Introductory Talk - Film
- AFTERNOON TEA
- Tour of Plant
- 4.15 PM Bus departs Carrum for return to Sheraton
Arriving approx. 5.00 pm
- 6.00 PM Cocktail Party - Australian Government
to
7.30 PM Treasury Room,
Sheraton Hotel

DAY 3 - TUESDAY, 1ST MARCH, 1983

- 9.00 AM Paper - Assessing the Potential for Waste Heat Recovery Projects
Speaker - Mr. L.M. Adams
Engineer in Charge,
Consultancy Services,
Energy Management Centre,
Gas & Fuel Corporation. Melbourne.
Question Time
- 10.45 AM MORNING TEA
- 11.00 AM Paper - Optimising Power Generation and Heat Generation through Co-generation
Speaker - Mr. A. Smithson,
Manager,
Industrial Gas Division,
South Australian Gas Company. South Australia.
Question Time
- 12.30 PM LUNCH
(Own arrangements)
- 2.00 PM Paper - Energy Conservation in a Real Life Project (\$163 M Pulp Mill Project)
Speakers - Mr. A. Campbell, Engineering Manager/MKM
Mr. G. Gough, Manufacturing Manager/MKM
Australian Paper Mills,
Maryvale.
- 3.00 PM AFTERNOON TEA
- 3.15 PM Question Time
to
4.00 PM

DAY 4 - WEDNESDAY, 2ND MARCH, 1983

7.50 AM Assemble in Hotel foyer.

8.00 AM Bus departs Hotel for visit to -
State Electricity Commission of Victoria,
Open Cut - Hazelwood Power Station,
Briquette Factory,
MORWELL.

Including MORNING TEA

12.30 PM LUNCH
Parkdale Restaurant, Morwell

2.00 PM Visit to -
Australian Paper Mills, Maryvale Plant
- and -
Sulphite Recovery Plant
Including AFTERNOON TEA

4.00 PM Return to Melbourne
Arriving approx. 6.00pm.

DAY 5 - THURSDAY, 3RD MARCH, 1983

- 8.20 AM Assembly in Hotel foyer.
- 8.30 AM Bus departs Sheraton for full morning visit to -
Gas and Fuel Corporation,
Energy Management Centre,
Clayton.
- Paper - Using Energy Management Centres to Implement
National Energy Conservation Programmes.
- Speaker - Mr. K.J. Westall,
Engineer in Charge,
Energy Management Centre.

MORNING TEA

Instructional tour of Energy Management Centre

- 11.45 AM Bus departs Clayton for return to Sheraton

- 12.30 PM LUNCH
(Own Arrangements)

- 2.00 PM Paper - Heat Recovery in Dairy Factories
Speaker - Mr. G. Cox,
Chemical Engineer,
Gilbert and Chandler Institute of Dairy Technology.

- 3.00 PM AFTERNOON TEA

- 3.15 PM Questions and Answers

- 4.00 PM Film - "Energy Conservation"
by courtesy of
National Coal Board, United Kingdom.

DAY 6 - FRIDAY 4TH MARCH, 1983

- 9.30 AM Paper - Fluidised-Bed Combustion - An Introduction
- 10.00 AM Video - C.S.I.R.O. Coal Research Film
- 10.30 AM MORNING TEA
- 11.00 AM Paper - Commercial Application of Fluidised-Bed Combustion
- 11.30 AM Video - The C.S.I.R.O./Joint Coal Board Project
- 12.00 PM Discussion
- Speaker - Dr. R. D. La Nauze,
C.S.I.R.O.,
Fossils Division
- 12.30 PM LUNCH
(Own Arrangements)
- 1.30 PM Afternoon available for discussion by attendees.

DAY 7 - SATURDAY, 5TH MARCH, 1983

FREE ALL DAY

DAY 8 - SUNDAY, 6TH MARCH, 1983

- 8.35 AM Assemble in Hotel foyer
- 8.45 AM Bus departs Sheraton Hotel for a sight seeing visit to -
Healesville Sanctuary
- MORNING TEA and LUNCH included
- Return to Melbourne
- Arriving approx. 3.30pm.
- 4.30 PM DINNER hosted by Presha Engineering at Kenloch Restaurant,
Olinda, preceded by cocktails at residence of
Mr. John Wrigglesworth (Managing Director, Presha Engineering)*
- Bus departs Sheraton Hotel 4.30pm.

DAY 9 - MONDAY, 7TH MARCH, 1983

FULL DAY VISIT TO -

- 1) S.E.C. Energy Utilisation Centre - Ormond
- 2) Gas & Fuel Corporation, L. & G. - Dandenong

8.50 AM Assemble in Hotel foyer
9.00 AM Bus departs Sheraton Hotel
Arriving Ormond 9.45am

MORNING TEA and LUNCH will be provided by S.E.C.

1.30 PM Bus departs for Gas and Fuel, L. & G. Centre

AFTERNOON TEA will be provided

4.00 PM Bus departs for Sheraton Hotel
Arriving approx. 5.00pm

DAY 10 - TUESDAY, 8TH MARCH, 1983

9.00 AM

Paper - Energy Conservation in Industry

Speaker - Mr. C.W. Peterson,
Corporate Energy Manager,
I.C.I. Australia Operations Pty. Ltd.

10.00 AM

Paper - Application of Thermo Dynamic Principles to
Optimise Energy Conservation Design.Speaker - Mr. Ken Davies,
Energy Co-ordinator,
Mobil Limited.

MORNING TEA

Paper - Heat Exchanger Network Design

Speaker - Mr. Ken Davies,
Energy Co-ordinator,
Mobil Limited.

12.15 AM

LUNCH

(Own Arrangements)

2.00 PM

Programme involving Delegates in providing information
of their own Waste Heat problems.

Discussions/Debates

Chairman - Mr. Ken Davies
Energy Conservation Co-ordinator,
Mobil Limited.

Panel

Mr. Kern Gordon,
President,
Peabody Gordon-Piatt,
U.S.A.Mr. C.W. Peterson,
Corporate Energy Manager,
I.C.I. Australia Operations Pty. Ltd.

DAY II - WEDNESDAY, 9TH MARCH, 1983

FULL DAY VISIT TO BALLARAT

8.05 AM Assemble in Hotel foyer
8.15 AM Bus to depart Sheraton Hotel
9.45 AM Arriving Ballarat
Visit to McCain Foods, Bio Gas Plant

MORNING TEA

11.15 AM Civic Reception, Mayor of Ballarat

LUNCH

"La Scallia Restaurant"
by courtesy of Gas and Fuel Corporation of Victoria

1.45 PM Visit to Sovereign Hill
3.45 PM Bus leaves
5.00 PM Arrival at Sheraton Hotel

DAY 12 - THURSDAY, 10TH MARCH, 1983

9.00 AM Paper - Waste Fuel Burning, Waste Heat Recovery

MORNING TEA

Paper - Boiler Economiser

Speaker - Mr. Kern Gordon,
President,
Peabody Gordon & Piatt,
Winfield. U.S.A.

11.15 AM Questions and Answers

12.15 PM

LUNCH

(Own Arrangements)

1.20 PM Assemble in Hotel foyer

1.30 PM Bus departs for visit to -

Smorgon Consolidated Industries - Footscray.

Presentation by Mr. P. Krasnostein (Director)

Tour of Paper Plant -

Power and Steam Generation Incorporating
Total Energy System.

REFRESHMENTS

4.30 PM Bus departs for Sheraton Hotel

DAY 13 - FRIDAY 11TH MARCH, 1983

9.00 AM Winding up of Workshop

Seminar Notes

Workshop Review

12.00 PM CLOSE



