



**TOGETHER**  
*for a sustainable future*

## OCCASION

This publication has been made available to the public on the occasion of the 50<sup>th</sup> anniversary of the United Nations Industrial Development Organisation.



**TOGETHER**  
*for a sustainable future*

## DISCLAIMER

This document has been produced without formal United Nations editing. The designations employed and the presentation of the material in this document do not imply the expression of any opinion whatsoever on the part of the Secretariat of the United Nations Industrial Development Organization (UNIDO) concerning the legal status of any country, territory, city or area or of its authorities, or concerning the delimitation of its frontiers or boundaries, or its economic system or degree of development. Designations such as “developed”, “industrialized” and “developing” are intended for statistical convenience and do not necessarily express a judgment about the stage reached by a particular country or area in the development process. Mention of firm names or commercial products does not constitute an endorsement by UNIDO.

## FAIR USE POLICY

Any part of this publication may be quoted and referenced for educational and research purposes without additional permission from UNIDO. However, those who make use of quoting and referencing this publication are requested to follow the Fair Use Policy of giving due credit to UNIDO.

## CONTACT

Please contact [publications@unido.org](mailto:publications@unido.org) for further information concerning UNIDO publications.

For more information about UNIDO, please visit us at [www.unido.org](http://www.unido.org)



UNITED NATIONS INDUSTRIAL DEVELOPMENT ORGANIZATION

---

# ANNUAL REPORT OF UNIDO 1990

Industrial Development Board  
Eighth session, 1991

The designations employed and the presentation of material in this publication do not imply the expression of any opinion whatsoever on the part of the Secretariat of the United Nations Industrial Development Organization concerning the legal status of any country, territory, city or area or of its authorities, or concerning the delimitation of its frontiers or boundaries.

Distr.  
GENERAL

IDB. 8/10  
25 March 1991

Original: ENGLISH  
Distr.: 12 April 1991

ISSN 0258-8137

## CONTENTS

	<u>Page</u>
Abbreviations .....	v
<b>CHAPTER I. POLICY ISSUES .....</b>	<b>1</b>
<b>CHAPTER II. INDUSTRIAL STRATEGIES AND OPERATIONS .....</b>	<b>7</b>
<b>A. Industrial policies and perspectives .....</b>	<b>7</b>
<b>B. Technical co-operation .....</b>	<b>9</b>
<b>I. Programme and project development .....</b>	<b>9</b>
<b>II. Implementation overall in 1990 .....</b>	<b>15</b>
<b>III. Implementation of industrial operations</b>	
by field of activity .....	16
Agro-based industries .....	16
Chemical industries .....	37
Metallurgical industries .....	41
Engineering industries .....	42
Industrial planning .....	44
Institutional infrastructure .....	46
Industrial management and rehabilitation.....	48
Feasibility studies .....	50
Industrial human resource development .....	51
Integrated industrial projects .....	52
<b>CHAPTER III. INDUSTRIAL PROMOTION .....</b>	<b>54</b>
System of Consultations .....	54
Development and transfer of technology .....	56
Industrial Investment Programme .....	60
<b>CHAPTER IV. SPECIAL THEMES .....</b>	<b>64</b>
Industrial Development Decade for Africa .....	64
Assistance to the least developed countries .....	65
Industrial co-operation among developing countries ....	66
Integration of women in industrial development .....	67
Co-operation with industrial enterprises	
and non-governmental organizations .....	68
Environment .....	69

CONTENTS (continued)

	<u>Page</u>
CHAPTER V. APPRAISAL AND EVALUATION .....	72
CHAPTER VI. CO-ORDINATION, FIELD AND LIAISON ACTIVITIES AND PUBLIC INFORMATION .....	74
Relations with Governments and intergovernmental organizations .....	74
UNIDO field representation .....	74
Public relations and information .....	76
New York Liaison .....	77
Geneva Liaison .....	78
CHAPTER VII. GENERAL ADMINISTRATION .....	80
Staffing .....	80
Human resource planning .....	81
Project personnel recruitment and administration .....	85
General services .....	87
Conference services .....	90
CHAPTER VIII. SOURCES OF FUNDS .....	93
A. Financing of technical co-operation activities .....	93
UNDP indicative planning figure and cost sharing .....	93
Special Industrial Services programme .....	93
Technical co-operation - regular budget allocations .....	94
Operational budget .....	94
Industrial Development Fund .....	95
Trust funds and self-financing arrangements .....	95
Programme support costs .....	97
B. Regular budget .....	99
STATISTICAL ANNEX .....	101
APPENDICES .....	115

## ABBREVIATIONS

ACC	Administrative Committee on Co-ordination
AMU	Arab Maghreb Union
ASEAN	Association of South-East Asian Nations
CAD/CAM	computer-aided design/computer-aided manufacturing
CPC	Committee for Programme and Co-ordination
ECA	Economic Commission for Africa
ECDC	economic co-operation among developing countries
ECDC/TCDC	economic and technical co-operation among developing countries
EDP	electronic data-processing
ESCWA	Economic and Social Commission for Western Asia
FAO	Food and Agriculture Organization of the United Nations
IAEA	International Atomic Energy Agency
ICGEB	International Centre for Genetic Engineering and Biotechnology
IDDA	Industrial Development Decade for Africa
IDF	Industrial Development Fund
ILO	International Labour Organisation
IPF	indicative planning figure
ITC	International Trade Centre UNCTAD/GATT
JPO	Junior Professional Officer
LDC	least developed country
NGO	non-governmental organization
OAU	Organization of African Unity
PTA	Preferential Trade Area for Eastern and Southern African States
RP	regular programme
XA	regular programme of technical co-operation - IDDA
XP	regular programme of technical co-operation - excluding IDDA
R and D	research and development
SELA	Latin American Economic System
SIS	Special Industrial Services programme
UCD	UNIDO Country Director
UNCTAD	United Nations Conference on Trade and Development
UNDP	United Nations Development Programme
UNEP	United Nations Environment Programme
UNESCO	United Nations Educational, Scientific and Cultural Organization
UNICEF	United Nations Children's Fund
UNOV	United Nations Office at Vienna
VIC	Vienna International Centre
WHO	World Health Organization

## EXPLANATORY NOTE

The present report makes cross-references in parentheses to the subprogrammes, programme elements and outputs as described in the programme and budget, 1990-1991, adopted by the General Conference (GC.3/10/Rev.1).

## CHAPTER I. POLICY ISSUES

1. The prospects of "an assured cash flow and an appreciably larger reserve under the operational budget" hinted at in last year's report <sup>1/</sup> and the sense of confidence they lent the Organization were dashed in the course of 1990. With a rapidly depreciating dollar and the inability on the part of some Member States to pay their assessed contributions, the Organization found itself compelled to return to survival strategies and eke out its limited financial resources.

2. The gravity of the situation is best evidenced by the paucity of the Organization's reserves. At one stage in the year - late October - the Organization had only \$2.4 million in its regular budget, of which \$767,600 were in the Working Capital Fund. This nadir was directly attributable to the fact that at that particular juncture no less than 105 Member States (out of a total of 151) were still in arrears. At the end of the year, outstanding contributions amounted to \$34.2 million representing 36.2 per cent of the 1990 assessment. It should be stressed once again that any further increase in the efficiency and productivity of the Secretariat is determined by Member States honouring their commitments. Assessed contributions should be paid fully in accordance with financial regulations, and not as late and partial payments which only serve to curtail programmed activities.

3. Other factors also contributed to the Organization's financial difficulties: unforeseen salary cost increases; diminishing investment income due to contributions being withheld; escalating electronic data-processing (EDP) costs; and higher maintenance costs for the Vienna International Centre complex. The net result is a substantial budgetary gap expected for the biennium 1990-1991, the closing of which will hardly be facilitated by the need to maintain a vacancy factor of at least 9 per cent throughout 1990-1991 as opposed to the 5 per cent level that was required in the period 1988-1989.

4. Despite the cash-flow constraints, the Organization was able to meet certain overall objectives that underlay the programme and budgets drawn up for the first year of the 1990-1991 biennium. Of particular significance was the fact that the Organization increased its technical co-operation deliveries yet again. The prime contributory factor to this continued improvement in the Organization's performance, despite severe constraints, was the unflagging commitment of its staff, who helped to boost technical co-operation

deliveries from \$133.8 million in 1989 to \$159.6 million in 1990, an increase of \$25.8 million or 19.3 per cent. Over the same period, project approvals dipped slightly from \$171.5 million to \$162.7 million, whereas the value of projects scheduled for implementation, the stock of UNIDO projects, rose from \$252.5 million at the end of 1989 to \$255.6 million at the end of 1990.

5. As a result of the increased delivery, the operational budget reserve also experienced an increase in 1990 - up from \$11.4 million at the outset of the year to \$12.7 million at the end of the year. Indeed, in the first quarter of 1991, the prospects for technical assistance delivery looked good. Based on an analysis of trends over the past five years and the relationship between the value of Project Allotment Documents in the Department of Industrial Operations in the first quarter of any year and the final delivery figures, the indications are that the technical co-operation delivery will rise still further in 1991. Ultimately, however, this is governed by three factors: (a) changes in the external environment that are difficult to predict in the light of the situation in the Gulf region, which accounts for almost 11 per cent of the Organization's delivery; (b) the UNDP approval rate of pipeline projects submitted by UNIDO; and (c) the assurance of a high collection rate of assessed contributions, the absence of which has a deleterious effect on the Organization's cash flow.

6. This quantitative increase was also matched by a qualitative gain. This was assured by careful appraisal and evaluation procedures. The first procedure, undertaken prior to approval, assesses the relevance and feasibility of a project and its potential effectiveness in solving well-defined problems. The second, undertaken after or during implementation, assesses actual project performance and analyses output and impact in the light of project objectives. The findings are increasingly used by the Secretariat and donors alike in deciding on project management and funding. The number of projects appraised in 1990 rose to 521, a slight increase over 1989 (505) and the appraisal process was extended to include the assessment of the environmental impact of projects. The number of project performance evaluation reports processed in 1990 also rose to 242, thus maintaining the high level of activity that had been reached in 1989 when 234 project performance evaluation reports were processed. Tripartite in-depth evaluations experienced a marked increase: up from 18 in 1989 to 36 in 1990, thus far surpassing the level of earlier years (27 in 1988 and 20 in 1987). The year also witnessed completion of the second major programme

<sup>1/</sup> IOB.6/10, chap. I, para. 1.

evaluation, focusing on the industrial investment identification and preparation activities, the findings of which will be presented to the Industrial Development Board at its eighth session. Clear qualitative improvements in technical co-operation deliveries were also registered. In 1988, 55.9 per cent of the projects evaluated were rated successful; in 1989 the figure increased to 59.3. The figures for 1990 (which are expected to indicate a continuation of the upward trend) will become available in the course of 1991. Further details of both the appraisal and evaluation exercises are to be found in chapter V.

7. As mentioned above, the increased and improved output was mainly achieved through enhanced staff productivity. This was accompanied by a judicious redeployment of resources from support services to operational activities. Computerization also played, and will continue to play, an important role in improving efficiency in the Secretariat and enabling it to maintain its key functions in a rapidly changing world. For this reason and in order to accommodate its changing and growing needs, UNIDO established its own computer facility at the outset of the year, relinquishing its central processing capacity in the computer of the International Atomic Energy Agency (IAEA) that was then used to accommodate the growing demand of the Agency.

8. Originally envisaged as a programme that could be financed "through the redeployment of resources at present earmarked for the joint computer services provided by IAEA and, if necessary, through economies in staff and non-staff expenditures", 2/ the elements and costs of the original computerization programme subsequently changed, culminating in a total cost of \$44.36 million over a six-year period. The planning lapses and related lacunae that led to the increase in estimated expenses were duly recognized and steps were taken to rectify them. An appropriately reduced EDP package was submitted to the seventh session of the Board, which, in its decision IDB.7/Dec.26, requested the External Auditor to examine in depth all aspects of the acquisition of the EDP system and to report on the matter in terms of conformity with or departure from financial propriety, procedural responsibility and fiscal management. These endeavours were reinforced by the Internal Audit Unit in the Office of the Director-General (see chap. V, paras. 15-16) which reviewed the issues related to the EDP programme. The Board also decided to establish a working group of independent experts. The experts would reassess the computerization needs of UNIDO from a technical standpoint, examine the contractual aspects of the matter, study the financial options open to UNIDO and make its recommendations on the EDP system as a

whole. The working group was expected to take up its deliberations early in 1991, and its report, together with the reports from the External Auditor and the Director-General, are scheduled for submission, through the Programme and Budget Committee, to the Board at its eighth session.

9. Two other major objectives in the current biennium are the effective mobilization of project financing resources and the development of policies, mechanisms and systems for generating technical co-operation projects under self-financing and third-party trust fund arrangements. The outcome of the Organization's endeavours is reflected in the growth in trust fund project delivery and the continued financial support that Member States lent to the Industrial Development Fund. Project expenditures under self-financed and third-party trust fund schemes increased from \$16.5 million in 1989 to \$25.7 million in 1990. Pledges to the Industrial Development Fund totalled \$29.8 million in 1990 as compared to \$39.3 million the year before. Considering that the 1989 figure included an exceptionally large one-time contribution from one donor country to the leather and other programmes, 3/ a comparison with that year would not be realistic. The figure for 1990 represents an increase of \$3.9 million, or 15 per cent, over 1988. This welcome development was mainly attributable to an increase in the size of the pledges from a number of donors.

10. The endeavours to secure alternative sources of project funding assumed particular importance in the course of the year in the light of the decision adopted by the Governing Council of the United Nations Development Programme (UNDP) regarding successor arrangements for agency support costs. The new arrangements bear particular implications for UNIDO and its ability to deliver technical co-operation projects, since some 60 per cent of the Organization's operational budget is funded from support cost income generated by UNDP-financed operational activities. These arrangements, which are still being negotiated with UNDP, derived from UNDP Governing Council decision 90/26 (see chap. VIII, paras. 31-36). That decision established an essentially new approach for calculating support costs in respect of the five major executing agencies which would be expected to provide three distinct sets of services to UNDP operational activities: (a) technical support at the programme level, related to non-project services; (b) technical support at the project level; and (c) administrative and operational support to projects including all non-technical services related to project implementation. Two per cent of programmable resources were to be set aside for each of the first two

2/ GC.3/10/Rev. 1, para. 30.

3/ IDB.6/10, chap. VIII, para. 20.



facilities and would be managed centrally, while a sum equivalent to 10 per cent of indicative planning figures (IPF) was to be transferred to a subline of the IPFs, whence it could be drawn upon by Governments to finance administrative and operational services as required.

11. Whereas the Governing Council decision allowed for more "upstream" or policy level work by agencies and provided Governments with an incentive to assume charge of administrative and operational support to projects, the major agencies expressed concern that the amounts provided, especially those for technical support services at the project level, were insufficient and would not ensure provision of adequate support. An initial assessment of the impact of the decision on the operational budget of UNIDO was given in document PBC.6/CRP.9.

12. At the present juncture with many details still undecided, a full-scale assessment of the successor arrangements and their impact would be premature. It is almost impossible to predict the extent to which Governments will continue to use agencies as providers of the administrative and operational support to projects. Agencies are undoubtedly in an excellent position to provide high-quality services efficiently, especially in combination with technical support services, yet project authorities may be tempted to "save" the IPF subline resources by attempting to forego this support too soon. In any event, the element of pronounced uncertainty induced by the new arrangements calls for adequate transitional arrangements that will allow the agencies to adjust their service capacities to actual demand, a factor that can only be assessed with any degree of certainty over the next biennium.

13. A further element of uncertainty is inherent in the very complexity of the definition and verification of support costs. This difficulty is compounded by the absence of a system-wide definition of what constitutes technical co-operation, yet clear and generally accepted principles of cost identification are essential to the calculation of real costs. In keeping with Programme and Budget Committee conclusion 1989/4, the Secretariat set about the task of developing an improved system for identifying and measuring the total cost of supporting operational activities (see chap. VIII, para. 36). The Board approved the new system of cost identification and requested that it be communicated to UNDP and specialized agencies as a response to UNDP Governing Council decision 90/26.

14. The changes taking place in the tripartite system of co-operation and the need to examine anew the range of services offered by UNIDO led the Secretariat not only to reassess its role in that evolving system of partnership, but also to examine closely the viability of its organizational structure and management systems and procedures. The Secretariat came to

recognize that, given the extent of change, UNIDO should equip itself to provide those services that Governments and UNDP would increasingly require in the future, while de-emphasizing those services that would be in less demand. The need for a shift in emphasis was also underscored by the Special Advisory Group to the Director-General in its deliberations on the Organization's activities in May. 'Focus', 'concentration' and 'excellence' were suggested as guiding principles in that regard. In the view of the Group, failure to adapt would incur the risk of the Organization being marginalized as a source of development assistance and technical support to Member States. It was therefore essential that the organizational structure and management systems of UNIDO be rationalized in the light of this reality - well ahead of the emerging trends, so that the Organization would be constantly in step with events rather than merely reacting to them.

15. The need to respond more quickly to the shifting international environment was also a key feature of the discussions in the Special Advisory Group which focused on two specific issues: the relocation of industries to developing countries; and energy and the environment. In respect of the first issue, a series of suggestions were made, ranging from expansion of the current Investment Promotion Service network, further analytical work as well as aspects relevant to industrial relocation, restructuring and foreign direct investment, to the introduction of programmes and projects aimed at establishing an environment conducive to investment in the developing countries. In undertaking these activities, UNIDO should seek to enhance inter-agency co-operation, improve complementarity and ensure an efficient division of labour.

16. In respect of the second issue, energy and the environment, the Group recognized the key role that UNIDO could play in developing and increasing existing sources of energy, in focusing on alternative technologies that were both more environment-friendly and more energy efficient, and in exploring alternative sources of energy supply. The programme that UNIDO had developed was welcomed by the Group whose members felt it could be revised and built up around the themes of 'energy for industry' and 'industry for energy'. Given the breadth of the Organization's proposals in both the energy and environmental sectors, the limited financial and human resources available to the Organization makes it all the more essential for a re-examination and prioritization of all ongoing activities, with the concomitant changes.

17. Any process of change designed to increase the efficiency and effectiveness of the Organization calls for the incorporation of modern management techniques, the introduction of new information systems and the acquisition of

computer skills. Throughout the year the Organization continued its endeavours to improve managerial efficiency and encourage organizational innovativeness. As in the previous year, human resources were seen to be of crucial importance to attaining the strategic vision of the Organization and achieving the objectives of the medium-term plan. Consequently, emphasis was placed on improving the utilization of staff talents and upgrading their professional skills in the areas of the Organization's technical competence, particularly in the priority areas of the medium-term plan.

18. Although staff training accounts for only a very small fraction of the Organization's payroll (staffing) costs and compares unfavourably with other organizations such as the United Nations Children's Fund or the World Bank, the situation improved slightly as training activities increased. By the end of 1990, performance, particularly in the field of computer-related training, had outstripped that of the previous year by 24 per cent. (For further details see chap. VII, para. 18.)

19. Recognition of the need for change also prompted the adoption of General Conference resolution GC.3/Res.20 in which the Director-General was requested to present, through the Board, to the fourth session of the Conference a report on his overall vision of the appropriate organizational and staff structure. An initial proposal for restructuring the Organization was outlined in a document presented to the Board at its seventh session.<sup>4/</sup> At the core of the restructuring proposal were four basic considerations. First was the need to sharpen the competitive edge of the Organization by strengthening its technical capabilities and improving the quality of its output. Second was the need to heighten the Organization's responsiveness to the changing needs of Member States and the enhancement of its capacity to manage UNIDO programmes at the country level. Third was the achievement of greater simplicity and clarity in its organizational structure. The fourth consideration was the adoption of a management system that would bring about improved efficiency through greater autonomy and accountability at the working level.

20. The proposed structure was so designed to permit the integration of functions currently performed by different units in UNIDO and facilitate co-ordination among staff along sectoral lines. It would also enable UNIDO to strengthen its capability to design and implement sectorally integrated programmes. If the proposed structure was to function properly, however, appropriate changes would have to be made in the system of management so as to enable the Organization

to deliver the desired services as quickly and cost-effectively as possible. This meant establishing a system of delegating decision-making authority on operational matters to the operating units and correspondingly shortening the lines of command and communication within the Organization. As proposed, the new style of management gave primacy to performance, while offering greater operational latitude to programme managers. Feedback and control were to be assured through continuous monitoring of programme, project and financial performance and through evaluation exercises. To the extent that performance of staff was tied to the achievement of objectives which, in turn, was linked to the allocation of resources, the sense of accountability in the Organization would be accordingly enhanced. It was also proposed to reinforce the new management system by adopting a more effective and efficient system of programme and project management entailing a revised project cycle.

21. At the seventh session of the Board, the proposed structure was the subject of extensive debate when it was recognized that there was a need for UNIDO to adapt fully its structure to the changing needs of developing countries in a changing world. The Director-General was requested, in decision IDB.7/Dec.23, to continue to update and revise his vision of the organizational and staff structure of UNIDO. That decision also established an open-ended working group of the Board, under the guidance of the Bureau, to review the matter and report to the next session of the Programme and Budget Committee. To that end, a schedule of meetings was drawn up for the first three months of 1991 and informal consultations had already begun in the final weeks of 1990.

22. The proposed restructuring notwithstanding, changes were introduced in the course of 1990 as part of the process of continual reform. An Environment Co-ordination Unit was established in the Special Measures and Activities Division of the Department for Programme and Project Development to act as the focal point for co-ordinating environmental activities throughout the Organization. The Industrial Investment Division in the Department for Industrial Promotion, Consultations and Technology was re-organized along regional lines, while responsibility for programme formulation and management and investment promotion office support services was vested in the Office of the Director. Advisory committees were also set up for the preparation of and follow-up to Consultation meetings, the basic aim being to help integrate the consultation process with all UNIDO activities relating to the sectors or topics covered by the System of Consultations.

23. These changes were closely related to the primary objectives of developing an integrated promotional approach to industrialization and promoting cleaner,

4/ IDB.7/33.

safer, energy-saving and cost-effective technologies. The efforts were rewarded not only by an increase in the industrial investment projects successfully promoted - up from 143 projects valued at \$556.4 million in 1989 to 170 projects valued at \$699 million in 1990. This upswing is attributable for the most part to the conclusion of a number of major investment projects in Poland. Furthermore, UNIDO strengthened its ties with major financial institutions such as the World Bank within the framework of the Industrial Development Decade for Africa and the Inter-American Development Bank with which it embarked upon a joint project identification exercise. UNIDO had also strengthened its ties with subregional groupings such as the Andean Development Corporation in the field of industrial investment promotion. A number of countries contributed in cash or in kind to the newly launched UNIDO environment programme. Other countries displayed interest in the environment-related activities of UNIDO, while more countries expressed the desire to join the Investment Promotion Service network as evidenced by Czechoslovakia, Greece, Islamic Republic of Iran, Portugal and Turkey.

24. Integration was also a key feature of the new programming and budgeting proposals submitted to the Programme and Budget Committee and the Board. Based on the principles of transparency, brevity and simplicity, the new programme and budget format, which was approved by the Industrial Development Board at its seventh session (IDB.7/Dec.11), has an overall framework evolving from the priorities set in the medium-term plan. The individual subprogramme, programme and major programme descriptions, which are presented along the lines of the Organization's structure, relate to that framework which is presented in holistic terms in the introduction. In addition to providing a clearer depiction of the future, the new format, which was used to prepare the programme and budget proposals for 1992-1993, will also have a bearing on the manner on which the achievement of objectives, the meeting of priorities and actual performance are reported. Once fully synchronized, programme reporting of the Organization's performance can be conducted, as the Board envisaged, on the basis of three documents: the programme and budgets, the annual report, and the financial statements. Through this simplified system, a more result-based and transparent programme budgeting and reporting system will be assured. This, in turn, should facilitate the task of Member States and others concerned with monitoring the implementation of the biennial work programmes of the Organization and the achievement of its goals as it sets about the task of assisting the developing countries to prepare themselves for the technological and other challenges of the 1990s. While this new reporting system will only come fully into operation in 1993, an attempt is already being made to

reflect programme performance in the present Annual Report. To that effect and wherever possible, the reporting on activities carried out in 1990 makes cross-references to the subprogrammes, programme elements and outputs as described in the programme and budgets, 1990-1991, adopted by the General Conference (GC.3/10/Rev.1).

### Intergovernmental organs

25. In compliance with its decision IDB.5/Dec.46 on conduct of business and rationalization of proceedings, the Industrial Development Board held two regular sessions - sixth and seventh - in May/June and November respectively, 5/ while the Programme and Budget Committee held its sixth session in late June. 6/

26. At the first and second 1990 regular sessions of the Economic and Social Council, a number of resolutions were adopted which are of relevance to the work of UNIDO. 7/ Decisions adopted by the Governing Council of UNDP at its thirty-seventh session included some with important implications for UNIDO, in particular decision 90/26 on agency support costs (see para. 10 above and chap. VIII, paras. 31-36). 7/

27. Also the United Nations General Assembly at its forty-fifth session adopted decisions and resolutions which call for action by UNIDO. In particular, resolution 45/196 reaffirmed the role of UNIDO as the co-ordinating organ in the United Nations system having primary responsibility for promoting and accelerating industrial development and the transfer of industrial technology to developing countries. At the same time, it addressed a number of requests to UNIDO and the international community with the aim of enhancing international co-operation in industrial development. The resolution also stressed the role of UNIDO in assisting developing countries in the formulation of programmes and plans for industrialization in their countries, and recognized the contribution of the special trust fund schemes launched by UNIDO in developing alternatives to traditional assistance programmes. The General Assembly decided to include in its agenda on a biennial basis, starting with

5/ For the reports of the Industrial Development Board on the work of its sixth and seventh regular sessions see documents GC.4/2 and GC.4/3, respectively.

6/ For the report of the Programme and Budget Committee on the work of its sixth session see document IDB.7/14.

7/ A list of the relevant resolutions and decisions of the Economic and Social Council and the Governing Council of UNDP can be found in conference room paper IDB.7/CRP.1.

## Chapter I

its forty-sixth session, an item entitled "Industrial development co-operation and the diversification and modernization of productive activities in developing countries", and recommended that the Administrative Committee on Co-ordination examine ways and means of fostering United Nations system activities on the subject and report thereon, through the Secretary-General, to the General Assembly at its forty-sixth session.

28. Among other General Assembly resolutions of relevance to the work of UNIDO were resolution 45/199 adopting the

International Development Strategy for the Fourth United Nations Development Decade, resolution 45/206 on the implementation of the Programme of Action for the Least Developed Countries for the 1990s, and resolution 45/211 on the United Nations Conference on Environment and Development. 8/

---

8/ A list of the relevant resolutions and decisions of the United Nations General Assembly will be made available to the Board in a conference room paper.

## CHAPTER II. INDUSTRIAL STRATEGIES AND OPERATIONS

### A. INDUSTRIAL POLICIES AND PERSPECTIVES

1. As regards industrial policy and perspectives, the Organization was engaged in basic research and preparation of studies on the process of industrialization and the evolution of industrial policies from the global, regional and sectoral points of view. Such research and studies were realized for policy makers in developed and developing countries to elicit short- and long-term perspectives of industrialization; as support to this work, an industrial data base was maintained. Activities in support of technical co-operation included briefing and data inputs for programming missions and project formulation, extending policy advice for industrial review and planning, and improving data preparation and statistical control in developing countries. In the course of those activities, emphasis was placed on the priority areas of environment, industrial rehabilitation and mobilization of financial resources.

#### Country- and region-specific studies and programme support activities

2. Regional and country studies continued to play an important role in supporting technical and economic co-operation programming and in providing economic advisory services to a number of developing countries and subregional organizations.

3. In Africa, most countries continued to face major constraints to longer-term industrial recovery and studies for the region focused on issues connected with this recovery process. An overview was undertaken of prospects for and constraints to growth in several agro-industrial branches in some countries. In the context of rehabilitation and regeneration of African manufacturing industries, privatization issues have assumed significance and were the subject of a special study (E.3.2.04(ii)). Industrial structural analyses were carried out in Morocco (E.3.2.04(i)) and country reviews in Angola, Cameroon, and Namibia (E.3.2.01(i)). Support was provided to technical co-operation activities through inputs to programming missions (e.g. Uganda and Zambia) (E.3.2.01(iii)) with the aim of strengthening the UNIDO country focus and identifying key areas for technical co-operation. Work was also done in support of other UNIDO programmes in the region through national surveys of industrial rehabilitation needs (e.g. Kenya) (E.3.2.04(i)). An integrated industrial programme was drawn up for the countries of the Preferential Trade Area for Eastern and Southern African States (PTA)

(E.3.2.03(i)) which, once reviewed by the PTA Committee on Industrial Co-operation and the PTA Council of Ministers, will form the basis for the United Nations Development Programme (UNDP) fifth cycle regional programme and the subregional programme of the Second Industrial Development Decade for Africa (IDDA).

4. Issues related to the increasingly rapid technological changes and their policy implications were the main concerns underlying studies on informatics in the African context. A survey was being carried out on the use of computers for industrial management, with the aim of facilitating the development of technical co-operation programmes and enhancing international co-operation in the industrial sector. An overview of issues related to computerized industrial management information systems in Africa was completed based on a number of country studies, four of which (Algeria, Côte d'Ivoire, Egypt, Ethiopia) were carried out in 1990 (E.3.2.01(ii)). Work was also initiated in Africa on a large-scale project on the diffusion of automation technology in the manufacturing sector, with special reference to the textiles, clothing and footwear subsectors (E.3.2.01(ii)).

5. As regards the Asia and Pacific region, work was done in response to the rapid industrial restructuring taking place in many countries of the region and the increasing qualitative demands placed on industrial growth. This was reflected, for example, in country-specific pre-programming support provided in the Philippines and Thailand (E.3.2.01(ii)), where analytical reviews were prepared of the countries' current industrial structure and main prospects and constraints for future industrial development. In both studies, special emphasis was put on the need to achieve a better regional distribution of industrial development and an environmentally more sustainable industrial growth. Based on these analyses, critical areas for future technical co-operation were identified which are now being considered by UNDP and the Governments concerned for the next country programmes. In Viet Nam, a national seminar on the country's future industrial development was held in October. The seminar, organized jointly with UNIDO, reviewed the findings and conclusions of a UNIDO study on major constraints to industrial development in Viet Nam (E.3.2.01(ii)). Country Industrial Development Reviews were issued on India and Pakistan and similar reviews were finalized on China, Malaysia and Viet Nam (E.3.2.01(i)).

6. Current industrial development programmes in the Arab countries reflected the need for increased manufacturing products in the context of a growing population. Programming work was undertaken in Algeria,

Egypt, Jordan, Libyan Arab Jamahiriya, Morocco, Saudi Arabia and Tunisia (E.3.2.01(iii)). Advisory services on industrial policies and strategies were provided to the Syrian Arab Republic for its new five-year plan, 1991-1995, with special attention being given to the textiles, chemical, engineering and food industry subsectors (E.3.2.02(i)). Priorities for industrial co-operation between the three Maghreb countries were identified at a meeting on the subject held at Tunis, Tunisia, in October (E.3.2.03(i)). Taking into account the increased emphasis on small- and medium-scale industry, a study on this sector was carried out for the countries of the Gulf Co-operation Council (GCC) (E.3.2.02(ii)).

7. The majority of Latin American and Caribbean countries continued their struggle to implement economic stabilization programmes. Priority was given in their activities to industrial restructuring and the promotion of non-traditional exports; in that context various studies were carried out for the region. Thus an analysis on industrial restructuring was undertaken in Costa Rica with the focus on policy issues at the subsectoral level, covering textiles, leather, footwear, pharmaceuticals, metalworking and food processing. A seminar on industrial and technological development was held in Bolivia. Advisory work was under way on policies for enhancing productivity in priority industries in Jamaica including the possibility of introducing a flexible specialization system of production and financial incentives in the food-processing industry. Preparatory work on the financing of industrial modernization was initiated in several countries (E.3.2.02(i)).

8. With regard to the least developed countries (LDCs), a data base on industry in LDCs was established and a paper was prepared for the Second United Nations Conference on the Least Developed Countries held in Paris in September. Work on a plan of action for industry in LDCs was also initiated. Concerning promotion of international co-operation, papers were prepared for two Eureka Organization meetings dealing with possible partnerships in industrial R and D between Europe and developing countries (E.3.2.02(i)).

9. In Eastern Europe, the industrial transformation process was reviewed including the endeavours to promote direct foreign investment. To that end, a report was issued on recent foreign investment flows to the countries in that region in the context of recent trends in foreign direct investments to developing countries. A country review was prepared in connection with the Investment Forum held at Warsaw, Poland (E.3.2.03(i)).

#### Global issues and policy analysis

10. As in previous years, major emphasis was placed on the analysis and formulation

of the UNIDO perspective on global industrialization, in particular through the publication of Industry and Development: Global Report. The 1990/91 Report (ID/371), made available to Member States prior to the seventh session of the Industrial Development Board in November, presents an assessment of the immediate global economic outlook. Special issues addressed include an assessment of the benefits of economic growth in developing countries over the past three decades in terms of social indicators, as well as in terms of the greater availability and quality of industrial products. An analysis is presented of the industrial performance, policy and prospects for major regions of the world in an age characterized by global integration. Included in the Report is a special survey on industry and environment which appraises the impact of industrial development on natural resources, industrial pollution in selected industries, and the economic implications of industrial pollution abatement, showing that this issue is far more complex than simple sloganeering would suggest. The Report also provides surveys of the chemical industry, shipbuilding, textile machinery, phosphates, copper processing, iron-making, forging, petroleum refining, engineering plastics, consumer and industrial tissue paper, paper and board, leathermaking and shoemaking machinery, and soft drinks manufacturing. (E.3.1.01(i), E.3.1.02 and E.3.1.03)

11. In fulfilment of the work programme for 1990, several policy-oriented documents were prepared for the seventh session of the Board, i.e. on the restructuring of world industrial production and redeployment (IDB.7/18), external debt and industrial development (IDB.7/19), the effects of the external debt and the external debt servicing on the industrial development of the developing countries (IDB.7/20), the mobilization of financial resources for industrial development (IDB.7/22) and the possible UNIDO inputs into the operation of innovations for the financing of industry in developing countries (IDB.7/23). Contributions were also made to governing bodies of other United Nations organizations and specialized agencies, including inputs to the preparation of a new international development strategy. Guidelines for policy design and price reform in developing countries, with special reference to industry, were published through arrangements with a commercial publisher (E.3.1.01(ii) and E.3.1.02(i)). An issue of the journal Industry and Development was prepared, containing articles on the software industry, business failure in manufacturing, and the potential for trade in goods and services between developing countries based on an analysis of the petrochemical industry. Three further journals forecast for 1990 could not be issued for lack of funds (E.3.1.02(iii)).

## Industrial statistics and sectoral surveys

12. Work under this heading continued in three main areas: industrial statistics, sectoral surveys and technical co-operation. The data base on industrial statistics was updated, maintained and supplemented with more detailed statistics (E.3.3.01(ii)). Special emphasis was placed on those industrial sectors that change most rapidly, both in developed and in developing countries. The Handbook of Industrial Statistics 1990 was finalized and distributed by a commercial publisher (E.3.3.01(v)). Competing in a Global Economy, an empirical study on specialization and trade in manufactures, was printed by a commercial publisher and made available for sale (E.3.3.02(i)). The preparation began of "Africa in figures" (E.3.3.01(vi)) and a statistical handbook on countries of the Association of South-East Asian Nations (ASEAN); their publication is scheduled for 1991. A total of 33 copies of the UNIDO data base were sold and/or exchanged with international organizations, commercial firms, and research institutes (E.3.3.01(iv)).

13. Work continued on sectoral surveys dealing with non-ferrous metals, fine chemicals and the leather industry (E.3.3.02(ii)). The sectoral survey on non-ferrous metals industries places special emphasis on the impact of government policies and their effect on international competitiveness; it is scheduled for publication by a commercial publisher. The sectoral survey on fine chemicals has reached an advanced stage and will be completed in 1991. The portion of the survey on the leather industry that deals with issues of corporate strategy and the behaviour of firms in the international context will be presented at the tenth session of the Leather and Leather Products Industry Panel to be held at Madras, India, in February 1991.

14. As regards technical co-operation activities in data collection and computer systems for industrial statistics as well as on statistical process control - an important aspect of manufacturing efficiency - four projects were completed, two were ongoing and a number of further projects were prepared for implementation in 1991 (E.3.3.01(iii)). Activities in support of programme and project development for technical co-operation increased significantly particularly in connection with trust fund projects in the pharmaceutical industry (E.3.3.02(iii)).

## **B. TECHNICAL CO-OPERATION**

### **I. Programme and Project Development**

15. Programme and project development at all levels and the monitoring of implementation continued to represent a dual focus in all area programmes. The process

of building up a portfolio of pipeline projects was further intensified. As part of this effort, programming, programme review and project formulation missions were carried out and a number of UNDP mid-term country programme reviews were attended. Refinements continued to be made to the computer-based pipeline monitoring system to allow integration of the Appraisal and Project Review Committee data bases. The trend of programme development continues to show that UNIDO activities will increase in the areas of agro-industries and rehabilitation.

16. The level of overall project approvals reached \$162.7 million in 1990 (1989: \$171.5 million), which represents a decline of \$8.8 million. The decline was due in part to the fluctuation in size and composition of pledges to the Industrial Development Fund (IDF) following the sudden change of the pledging pattern of some donors, and in part to the inclusion of large and unprecedented approvals under trust funds in 1989. Chapter VIII, part A, provides additional details by sources of funds. The highlights of programme and project development in the individual regions are described in the following paragraphs.

### Africa Region

17. As in the past, programmes and projects carried out in the Africa region aimed at contributing to the interlinkages of the various sectors of the economy, thereby assisting in the creation of a viable industrial structure. This was in line with the broad diagnostic approach adopted in the UNDP country and regional programmes which has led to the recommendation of specific projects geared to the overall development strategy and priorities of the countries and subregional organizations concerned.

18. With regard to technical co-operation (E.2.1.01), an annual programme review was made in respect of 44 countries (44 forecast), and 376 projects already in the pipeline were further processed (490 forecast for the biennium); in addition 175 new national project proposals were identified, formulated and appraised (530 forecast for the biennium) as well as 68 regional and subregional project proposals (80 forecast for the biennium). Of these, 162 projects were developed and approved under the indicative planning figure (IPF) and under other sources of finance (50 under IPF and 210 under other sources of finance forecast for the biennium).

19. With all the country and regional programmes of the Africa region approved under the fourth UNDP country programming cycle, efforts focused primarily on formulation and approval of UNDP-financed projects and on identification and development of new projects for financing under UNIDO-administered funds (E.2.1.01(ii),(iii),(iv)). Thus, as of

# Technical co-operation delivery (TCD), project approvals (PA), and residual stock of projects (RSP)

(in millions of US dollars)

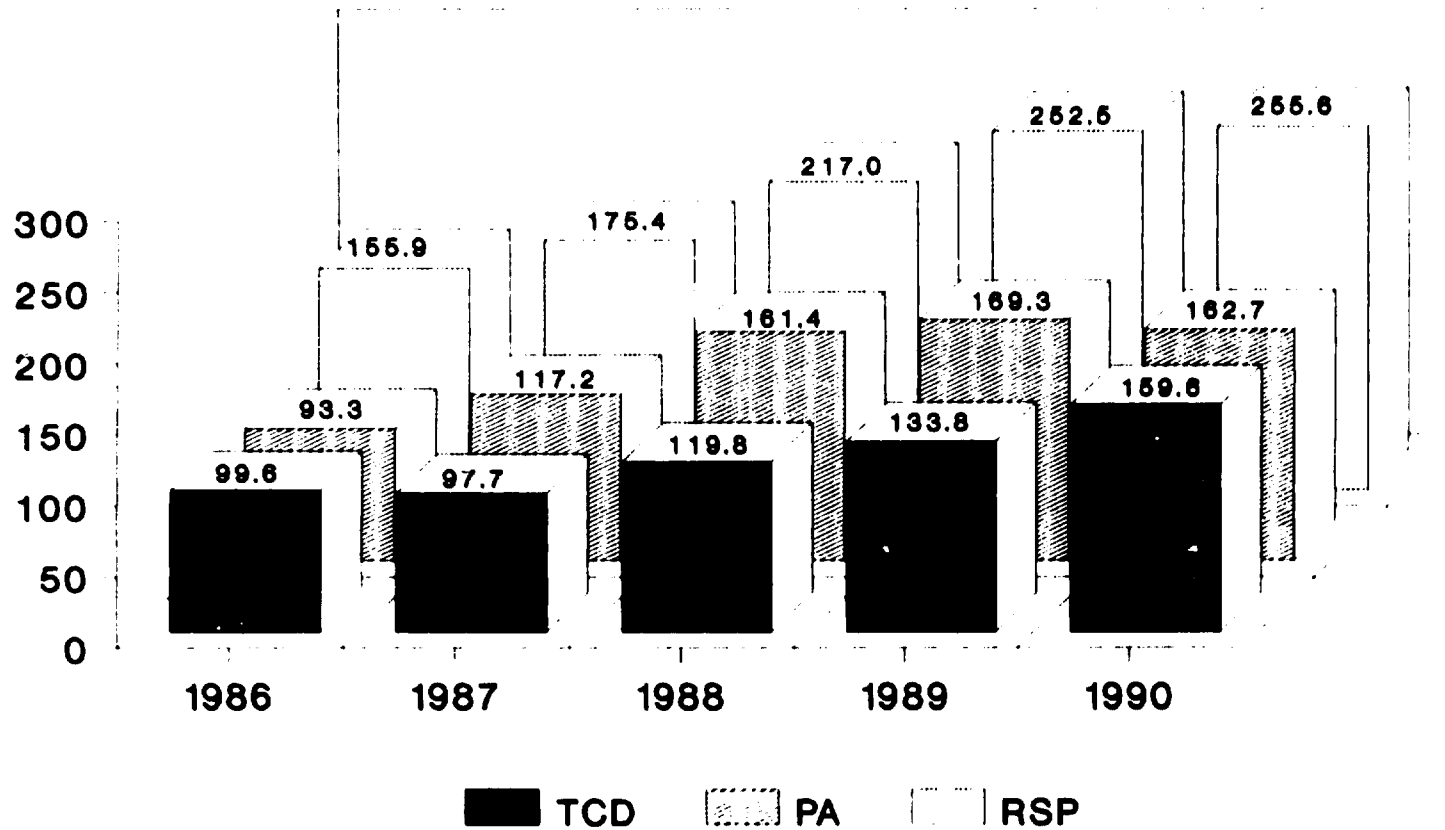



31 December 1990, 162 new projects were developed and approved (165 projects in 1989) amounting to \$27.0 million (\$32.5 million in 1989). The net approvals amounted to \$37.9 million (\$45.5 million in 1989). The decline of the volume of approvals in 1990 as compared to 1989 is attributed to the decline in project approvals under IDF, from \$13.7 million in 1989 to \$2.7 million during the current year. The high approval level in 1989 was mainly due to the unique special-purpose contribution of \$8.2 million for the leather programme in Africa. Approvals under other sources of funds, notably IPF, saw an increase in 1990. Thus, new projects approved under IPF went up from \$12.0 million in 1989 to \$14.0 million (an increase of 16.7 per cent), while approvals under the regular programme of technical co-operation, including IDDA, rose from \$1.7 million in 1989 to \$4.6 million in 1990.

20. Work concentrated on basically the same areas as the previous year. Thus, technical co-operation continued to centre around the support of various economic recovery plans and structural adjustment schemes initiated by the countries of the region with emphasis on institution-building, human resource development, technological development and economic management. Other areas of concentration included the development of small- and medium-scale industries, restructuring and rehabilitation of industrial enterprises and the integration of women in industrial development. Increasing emphasis was also given to environment issues. At the regional level, technical co-operation programmes and projects were developed to assist the intergovernmental organizations and institutions in addressing specific problems and, through them, to enhance industrial co-operation. Those activities included direct assistance to the re-organization of industrial programmes at the subregional level, the rehabilitation of industrial enterprises with the potential of serving the subregional market, the harmonization of technology development and utilization, and the organization of a wide range of training programmes, including on-the-job training, in-plant group training and demonstration workshops. Pilot demonstration and experimental projects were developed for selected branches of industries. Such projects also included the energy sector, with emphasis on biomass technology. Investment promotion meetings were organized for the Central, Eastern and Southern African subregions.

21. Another important area of work was the assessment of the implementation of the fourth UNDP country programming cycle to ascertain the quality and timely execution of projects by both government agencies and UNIDO. That assessment also helped in identifying Governments' priorities for the fifth UNDP country programming cycle (1992-1996). Towards that end, annual programme review and mid-term review

missions of the fourth UNDP programmes were sent to Angola, Burkina Faso, Central African Republic, Gambia, Ghana, Mali, Mauritania, Nigeria, Rwanda, Sao Tome and Principe, Sierra Leone, Togo and Zaire, while review missions for the industrial sector were sent to Botswana, Burundi, Congo, Kenya, Malawi, Togo and Uganda with regard to the preparation of the fifth UNDP country programmes. In some cases, as in Botswana and Congo, the missions were combined with programming missions for the Second IDDA. Most of the missions were financed from UNDP resources. (E.2.1.01(i),(v))

22. UNIDO participated in round-table meetings in Mauritania, Namibia, Sierra Leone and Togo organized by the respective Governments and UNDP. Co-operation between the World Bank and UNIDO in support of industrialization of the Africa region was intensified through consultations that took place at the headquarters of both organizations in particular with the Industry and Energy Division of the Africa Technical Department of the World Bank. Contributions were made to the report of the Secretary-General of the United Nations on monitoring the process of implementation of the United Nations Programme of Action for African Economic Recovery and Development 1986-1990 to be submitted to the United Nations General Assembly at its forty-sixth session. (E.2.1.01(vi))

### Arab States

23. The main feature of the economic development in the Arab States has continued to be the extreme exposure to the impact of external economic factors, chiefly because of the heavy dependence of many of those States on a single economic sector - revenues from oil exports. At the same time, most of their technology and food needs are met through imports from abroad. This situation has highlighted the importance of activities to pursue a more diversified economic base, to acquire food security, to gain proper technological development and to resolve the external debt problems.

24. With regard to technical co-operation (E.2.2.01), an annual programme review was made in respect of 20 countries (20 forecast), and 156 projects already in the pipeline were further processed (120 forecast for the biennium); in addition, 108 new project proposals were identified, formulated and appraised (270 forecast for the biennium). Of these, 84 projects were developed and approved under IPF and under other sources of finance (55 under IPF and 95 under other sources of finance forecast for the biennium).

25. By the beginning of 1990, Arab regional and subregional political and economic co-operation was progressing as a reflection of the need to adapt and adjust to the structural changes in the international economy and the emergence of major

integrated economic blocs (in particular the European Community). The sharp decline in oil prices in the first half of the current year inflicted severe damage on the economy of a number of Arab States. The situation deteriorated further through the Gulf crisis, which has affected relations among Arab countries and has also slowed down UNIDO activities in the area.

26. UNIDO participated in the mid-term review of the fourth UNDP country programmes for Egypt, Jordan, Libyan Arab Jamahiriya, Oman, Saudi Arabia and the Syrian Arab Republic. That occasion afforded an excellent opportunity to review ongoing UNIDO activities and to identify priority areas for technical co-operation to be either implemented immediately or to be considered for inclusion in the fifth UNDP programming cycle. (E.2.2.01(i),(v))

27. Many Arab States continued to emphasize the importance of the role played by the private sector in their industrial development. Requests were received from a number of Arab States for assistance in their efforts in the privatization process. The technical co-operation activities and projects identified during 1990 were mainly related to high technology and the introduction of computer application, standardization and quality control, agro-industries, human resource development, industrial planning, downstream petrochemicals, management improvement and rehabilitation of industrial plants in the public sector and investment promotion. There was a growing awareness of the need to include environmental aspects in technical co-operation activities and a number of proposals were made in that respect. (E.2.2.01(iii))

28. Against this background, the net approvals in 1990 from all sources of funds amounted to \$21.5 million (1989: \$9.5 million). This increase was achieved despite the fact that the fourth UNDP programming cycle was drawing to a close. Of the total amount, \$8.3 million were from IPF, \$0.5 million from the Special Industrial Services (SIS) programme, \$1.3 million from the regular programme of technical co-operation, \$0.8 million from IDP and \$10.6 million from trust funds and other sources. (E.2.2.01(ii),(iv))

29. UNIDO participated in the mid-term review of the Arab regional programme organized by UNDP and held at Damascus, Syrian Arab Republic, in October. The review identified the industrial sector as one of the priority areas for inclusion in the next regional programme. (E.2.2.01(i),(v))

30. A report for the Special Programme for Industrial Development in the Arab Countries established by the Board (IDB.5/Dec.26) was finalized in May. The report identified two major types of activities: activities aimed at meeting the urgent needs of the Arab least developed countries and activities for industrial co-operation at the regional level. (E.2.2.01(vi))

31. UNIDO continued its close co-operation with regional and subregional organizations, such as the Arab Industrial Development and Mining Organization, the Gulf Co-operation Council and the Gulf Organization for Industrial Consulting.

32. Efforts to provide technical assistance to the Palestinian people continued despite the prevailing circumstances in the occupied territories. Several project proposals have been developed for possible financing by UNDP, e.g. assistance for the establishment of a vegetable grading facility in Gaza and assistance for the establishment of a textile laboratory. The final report of a UNIDO-organized seminar, issued in May, contains recommendations for promoting industrial development in the occupied territories and will be a subject of co-operation with the Arab regional organizations. (E.2.2.01(iii))

### Asia and the Pacific Region

33. The principal activities in the region were directed towards the preparation for the fifth UNDP programming cycle. Missions took place to Afghanistan, Bhutan, Nepal, Philippines, Republic of Korea, Sri Lanka, Thailand and the South Pacific island countries with the aim of assisting UNDP in determining industrial development areas and identifying specific projects for technical co-operation. Where programming missions had already been carried out prior to 1990, as in the case of India and Indonesia, efforts were concentrated on the proper formulation of projects. In China, where no agency involvement was requested in the preparation of a new country programme, UNIDO assisted in the preparation of individual projects. Programming missions, during which projects are formulated, were planned in anticipation of requests from Pakistan and Viet Nam. Likewise, the ground was being prepared for the UNDP inter-country (regional) programme, account being taken of the three main themes proposed by UNDP for the region: human development, economic reform, and environment and conservation of nature. (E.2.3.01(i),(iii),(v))

34. With regard to technical co-operation (E.2.3.01), an annual programme review was made in respect of 36 countries (36 forecast), and 435 projects already in the pipeline were further processed (300 forecast for the biennium); in addition, 235 new project proposals were identified, formulated and appraised (260 forecast for the biennium). Of these, 133 projects were developed and approved under IPF and under other sources of finance (135 under IPF and 115 under other sources of finance forecast for the biennium).

35. In 1990 the net approvals from all sources of funds amounted to \$52.4 million (1989: \$58.1 million) of which \$41.7 million was from IPF, \$1.3 million from SIS, \$1.0 million from the regular programme of technical co-operation, \$4.4 million from

IDF and \$4.0 million from trust funds and other sources. (E.2.3.01(ii),(iv))

36. The Special Programme for the Industrial Development of Asia and the Pacific established by the Board (IDB.5/Dec.23) places emphasis on the rapid industrial growth of LDCs. In that context, the programme took an important step forward with the convening of an LDC workshop on agro-related metalworking industries held at Bangkok in November in association with the Economic and Social Commission for Asia and the Pacific and the Regional Network for Agricultural Machinery (RNAM). A total of 26 project proposals were identified for action at the national level and one at the regional level. The latter would aim at encouraging LDCs to participate in the Network, to enable them to make full use of RNAM facilities and draw advantages from its activities in prototype development, exchange of information, extension and other services. In the process, economic and technical co-operation will be promoted with other members of the Network. (E.2.3.01(vi))

37. Another emphasis of the Special Programme, namely the enhancement of the existing inter-country programme, was confirmed through the approval of a number of regional or subregional (e.g. ASEAN and the Mekong area) projects, ranging from assistance given to a regional network on pesticides development in the use of computer software for marketing information, treatment of tannery effluents, and research and human resource development in six pulp and paper institutes, to a number of studies, seminars, workshops and advisory missions covering topics such as industrial development strategy, environmental management and instrumentation servicing. (E.2.3.01(iii))

### Europe and Mediterranean Region

38. By the end of 1990 an overwhelming majority of projects had been approved under the fourth UNDP country programming cycle. Only a few projects were still under consideration by UNDP, including projects in Czechoslovakia. (E.2.4.01(iv))

39. During the year 1990 the net approvals amounted to \$4.9 million (1989: \$3.6 million), an increase of 36 per cent over 1989. This amount includes among other funds, \$1.9 million from IPF and \$0.9 million from SIS. (E.2.4.01(ii),(iv))

40. With regard to technical co-operation (E.2.4.01), an annual programme review was made in respect of 10 countries (10 forecast), and 63 projects already in the pipeline were further processed (35 forecast for the biennium); in addition, 83 new project proposals were identified, formulated and appraised (55 forecast for the biennium). Of these, 53 projects were developed and approved under IPF and under other sources of finance (15 under IPF and 40 under other sources of finance forecast for the biennium).

41. Recent political changes in Central and Eastern European countries resulted in efforts to transform the centrally-planned economies to market-oriented economies. The countries were facing enormous tasks of restructuring their economies, upgrading their technological and managerial capabilities as well as introducing market-oriented mechanisms to make their economies profitable, effective and competitive. Massive needs have been identified in the industrial sector, which is undergoing a restructuring process. Those needs range from opportunity surveys, pre-feasibility and feasibility studies for foreign investments and joint ventures, to direct assistance to industrial enterprises through technical advisory services, individual and group training for technical and managerial staff, and measures aimed at reducing industrial pollution and high energy consumption. (E.2.4.01(iii))

42. The needs were reflected in many requests addressed to UNIDO from the region. Joint efforts by donor and beneficiary countries through the UNIDO programming mechanism resulted in the establishment of a pledge for trust funds by some donor countries. (E.2.4.01(iv))

43. UNIDO continued to promote the activities of the joint committees for eight European countries. Bulgaria, Czechoslovakia, Hungary, Poland, Romania, Turkey, Union of Soviet Socialist Republics and Yugoslavia (E.2.4.01(i),(v)). These activities led to the development of "outreach" projects, whereby experience gained is shared with the developing countries for their benefit.

### Latin America and the Caribbean Region

44. The countries of the Latin America and Caribbean region continued to carry out intensive efforts to adjust their economies and to consolidate economic stabilization and restructuring programmes. Access to fresh financing continued nevertheless to be restricted and the terms of trade of most of the countries of the region continued to be depressed. All these factors contributed to the continued adverse performance of the industrial sector in the region.

45. Against this background and at the request of Member States, the UNIDO programme of technical co-operation focused on key areas for the industrial development and recovery of the region. These included the identification of new forms of co-operation in the fields of production, investment promotion, the introduction of advanced technologies, and activities in support of the modernization of industry and its international competitiveness. New modalities for direct assistance to industry were also promoted, including the development of special trust funds and access to technical assistance components of credit lines. Programmes were initiated to assist government institutions, industry and the

financial sector in obtaining greater insight into international restructuring in industry and industrial competitiveness, access to information on new and emerging process and product technologies, and total quality management. A number of projects of high technological content in specific industrial subsectors were initiated and new programmes in the field of energy and environment were actively promoted. (E.2.5.01(i),(ii),(iii),(iv),(v))

46. With respect to the Regional Co-operation Programme for the Industrial Recovery of Latin America and the Caribbean established by the Board (IDB.5/Dec.25), the first regional project on industrial sub-contracting financed by a special-purpose contribution from Italy to IDB was under implementation, while the programme for industrial automation of the capital goods industry in Latin America was formally approved by participating Governments and UNIDO. Venezuela is to host the programme and has also approved a sum of \$1.5 million towards its implementation. The programme has also been presented to prospective donors to IDB for their consideration. (E.2.5.01(viii))

47. During the year the net approvals reached \$9.5 million (1989: \$7.0 million) of which \$4.5 million was from IPF (1989: \$4.6 million) and \$5.0 million from other sources of funding (1989: \$2.4 million). In spite of the limited availability of funds in the fourth year of the current UNDP programming cycle and an increase in government-executed projects, the level of approval attained in 1990 constitutes an improvement over 1989, both with respect to the total value and the number of projects approved. (E.2.5.01(iv))

48. With regard to technical co-operation (E.2.5.01), an annual programme review was made in respect of 41 countries (41 forecast), and 170 projects already in the pipeline were further processed (120 forecast for the biennium); in addition, 169 new project proposals were identified, formulated and appraised (150 forecast for the biennium). Of these, 94 projects were developed and approved under IPF and under other source of finance (30 under IPF and 110 under other sources of finance forecast for the biennium).

### Global and Interregional Projects and Programmes

49. Technical co-operation activities at interregional/global levels including Governments, institutions, private and State enterprises were carried out at macro and policy levels as well as at micro and enterprise levels. The programme continued to emphasize human resource development, collective research and development, enterprise-to-enterprise co-operation including joint ventures, and restructuring and rehabilitation, in particular for small- and medium-scale industries. Activities related to environmental considerations in

industry were expanded. Some of the projects were developed in the context of UNIDO environment activities or were indirectly related to it, e.g. a project which may lead to international co-operation in the field of genetic engineering and environment, and projects on international safety guidelines for pesticides formulation and recycling of waste oil, which were approved in 1990 (E.2.4.02(ii)). Special efforts were made to ensure that successful and relevant country and regional technical co-operation activities are taken into consideration when formulating projects at the global and interregional levels.

50. Among the various activities related to transfer of technology, a proposal was formulated for pre-matching the needs of entrepreneurs in developing countries for technologies in chemical engineering, light industrial machinery, metallurgy and electronics, with the suppliers of technology from both industrialized and developing countries. This activity will be implemented as soon as the necessary funding is made available. Enterprise-to-enterprise co-operation programmes continued to grow, which led to a number of co-operative agreements in such subsectors as textile, agro-industry and agricultural components. Additional new areas and forms of co-operation at the enterprise level have also been looked at in 1990 that may take shape in future years (see also chap. IV, paras. 30-31) (E.2.4.02(ii)). The trend in recent years to focus on the above tasks is expected to continue in future.

51. In 1990, 185 interregional and global projects were approved and the net approvals amounted to \$35.8 million (1989: \$47.7 million). Of this amount, \$20.2 million was from IDB, \$0.8 million from the regular programme and \$14.8 million from trust funds. (E.2.4.02(i))

52. The planning and implementation of new global and interregional activities benefit from evaluation reports prepared for similar activities implemented earlier such as recurrent training and other programmes. In addition to the review exercises undertaken within the projects' cycle, more comprehensive evaluations were started in 1990 and will be soon completed, e.g. the evaluation of the investment promotion and training programmes (see chap. V, paras. 8, 14). They will provide additional concepts and recommendations to further increase the quality of global and interregional activities. (E.2.4.02(iii))

53. As a result of co-ordination efforts with the interregional and global programmes of UNDP, eight interregional projects amounting to \$1.2 million were jointly developed and approved in 1990 under the UNDP trust fund. (E.2.4.02(iv))

### Programme Development Support

54. Activities related to the application of an integrated approach to technical

co-operation programming concentrated on agro-industries and related subsectors in African countries. Typologies 1/ for the fertilizer industries of 50 African countries were published and presented at the eleventh session of the Food and Agriculture Organization of the United Nations Commission on Fertilizers in March, while work started on the publication of typologies for the pesticides and agricultural machinery industries. Techniques similar to those applied in the preparation of the sectoral typologies - i.e. the grouping of countries according to patterns of development of specific industrial systems - were also used to systematically identify the priority needs of African countries for technical co-operation and investments in the rehabilitation of agro-food processing industries. (E.1.3.01(iii))

55. Work continued on 24 indicative development programmes, 2/ for the agricultural machinery, fertilizer, pesticide and food-processing industries of 14 African countries. The fifth subsector, which was intended to be energy, was not covered due to lack of funds. Ten of the indicative programmes were completed covering eight countries (Central African Republic, Côte d'Ivoire, Egypt, Ethiopia, Ghana, Nigeria, United Republic of Tanzania and Zambia). The total value of technical co-operation and investment opportunities identified in the 10 programmes amounts to \$18.8 million and \$89.5 million, respectively. In all cases, local authorities participated directly in the formulation of the programmes. It is envisaged that a number of these programmes for the fertilizer, pesticide and fisheries industries in West African countries will involve intra-regional co-operation. (E.1.3.01(i),(iii))

56. With regard to the fisheries industrial system in West Africa, 3/ a \$57 million programme for Ghana was under consideration by the Government. For the management of this programme, the UNIDO trust fund mechanism was selected by the Government and the potential lenders. Preliminary promotion has indicated that the integrated programme finds great interest among Governments, local and foreign lenders and private sector entities. Seven foreign companies (five European and two Asian) expressed interest in participating in this programme through investment, joint ventures, the provision of assistance in manufacturing or assembling equipment for the fisheries industry, in quality control and in promoting the sales of finished products in the European market. (E.1.3.01(ii),(iii))

57. To ensure overall co-ordination and monitoring of the development and

1/ IOB.6/10, chap. II, paras. 52-53.

2/ Ibid., paras. 52-53, 55.

3/ Ibid., para. 54.

implementation of the integrated programmes in the agro-industries subsector in Africa, a co-ordinating committee on the integrated programme approach was established by the Director-General. Training in the use of the programme approach was given at Headquarters to government officials from Kenya, Kuwait, Sudan, Venezuela and Zambia. Briefing in the use of the programme approach methods was also given to consultants preparing the national programmes for the Second IDDA. Continuous improvement of data bases, computer tools and methods was undertaken, resulting in better production of documentation and software.

## II. Implementation overall in 1990

58. The largest portion of technical co-operation activities continued to be financed from UNDP resources (IPF, SIS, Special Programme Resources and Special Measures). Although total UNDP resources again increased from \$79.9 million in 1989 to \$94.3 million in 1990, the share within the overall implementation decreased slightly from 59.7 to 59.1 per cent. Overall expenditure on technical co-operation activities increased from \$133.8 million in 1989 to \$159.6 million in 1990.

59. The total of 1,896 projects implemented or under implementation in 1990 included 199 valued at \$1 million or more, 603 valued at \$150,000 or more, and 1,094 valued at less than \$150,000. Tables 1 and 2 below show the overall technical co-operation expenditure, by source of funds and project component.

60. A breakdown of technical co-operation delivery, by source of funds and project component, is given below for Africa (tables 3 and 4), the Arab States (tables 5 and 6), Asia and the Pacific (tables 7 and 8), Europe (tables 9 and 10), and Latin America and the Caribbean (tables 11 and 12).

61. The value of project delivery by UNIDO in Africa amounted to \$55.7 million (including \$14.8 million for African Arab States). The increase of \$6.6 million or 13.4 per cent (an increase of 1.1 million or 8.0 per cent for African Arab States) over the corresponding figure for 1989 was the result of a substantial increase in funds made available in 1990 from UNDP.

62. The value of projects implemented in the Arab States amounted to \$21.6 million (including the African Arab States). This constituted an increase of \$2.3 million or 11.9 per cent over the figures for 1989. The higher level of implementation was mainly the result of an increase of funds made available from UNDP for implementation in 1990.

63. The value of projects executed in Asia and the Pacific amounted to \$49.4 million, an increase of \$5.8 million or 13.3 per cent as compared to 1989. The higher level of implementation was mainly attributable to

an increase in financial resources made available from UNDP.

64. The value of technical co-operation delivery to Europe amounted to \$5.2 million, an increase of \$0.9 million or 20.9 per cent as compared to the implementation in 1989. The higher level of implementation is largely the result of an increase in UNFDAC, SIS and trust funds.

65. The value of projects executed in Latin America and the Caribbean amounted to \$11.2 million, a decrease of \$0.9 million or 7.4 per cent as compared to the figures for 1989. The lower level of expenditures is attributed to a decline of delivery under UNDP Indicative Planning Figure (IPF) by \$1.6 million (or by 9.0 per cent) caused mainly by the increase in government-executed projects in the region, as explained in the Annual Report, 1989 (IOB.6/10, chap. II, para. 46). In addition there was a decline in the approval by UNDP of new projects in the industrial sector in 1989. The decrease in 1990 could not fully be compensated by the remarkable increase in delivery under the funds managed by UNIDO, i.e. regular programme, trust funds, SIS, and IDP, which rose to \$0.3 million, \$0.6 million, \$1.0 million and \$2.1 million respectively, representing a growth of 114.8 per cent, 4.7 per cent, 11.4 per cent and 61.0 per cent respectively.

66. As outlined in the medium-term plan, 1990-1995 (GC.3/17), the technical co-operation activities in 1990 concentrated on the implementation of projects in the five priority problem areas: human resource development, development and transfer of technology, industrial rehabilitation, small- and medium-scale industries, and environment and energy, as well as on the three elements common to industrial development, including the thematic programmes: mobilization of financial resources for industrial development, economic co-operation among developing countries (ECDC) and subregional industrial co-operation, and the integration of women in industrial development. Furthermore, the efforts to improve the quality of the implementation of technical co-operation projects continued, taking into account the results of project performance evaluation reports, in-depth and thematic evaluations (see chap. V). Great emphasis was placed on the application of environment-friendly technologies in all technical co-operation projects.

67. Technical co-operation delivery by individual branches in the Department of Industrial Operations is treated in the paragraphs that follow. As many ongoing projects have been covered to some extent in previous Annual Reports, only brief accounts are given here, with appropriate references to those earlier Reports. It should be borne in mind that even though projects may be mentioned under specific "activity" headings (e.g. engineering industries), their implementation may cut

across organizational lines to include the economic and technical expertise of not only the entire Department of Industrial Operations, but of UNIDO as a whole. Thus, individual branches of the Department provide inputs to, and benefit from, the activities of the Department for Industrial Promotion, Consultations and Technology and the Department for Programme and Project Development.

68. The number of technical co-operation projects implemented or under implementation in 1990 and the regional distribution of technical co-operation delivery, by field of activity, are shown in tables 13 and 14 below. A further breakdown of the number of projects in progress and outputs completed in 1990, by programme element, is shown in table 15 below.

### III. Implementation of industrial operations by field of activity

#### AGRO-BASED INDUSTRIES

69. Technical co-operation expenditures under the heading of agro-industries (J.1.1) amounted to \$16.9 million. Some 54 per cent of the total implementation was financed from UNDP resources. A total of 152 projects were implemented or under implementation.

70. Activities related to agro-based industries focused on the production of value-added agro-based products, such as food and textiles, for local markets and on the improvement of quality standardization and controls for exports. In that context, the rehabilitation of existing production plants, especially in the food and leather sector, was an important activity. Due attention was also given to the development of clean technologies and the treatment of industrial effluents to avoid the negative effects to the environment of the industrialization process in the developing world. The economic and political needs for the development of small-scale rural activities were recognized as important factors in industrial development, and programmes have been designed for the integration of women in the industrial production process.

71. The technical co-operation programme in the textile and garment manufacturing sector, has grown over the years from a modest beginning to a multi-million dollar operation. At the same time its nature has changed from projects of direct assistance in the textile industry to projects linked to institutions in developing countries concerned with the application of the most advanced technologies both in primary processing and, increasingly, in garment manufacture. 4/ This change is a natural

4/ IOB.6/10, chap. II, para. 69.

outcome of global developments in the textile sector and is in line with the principle of assistance towards self-reliance in the developing countries. Direct assistance to factories tended to be effective only while it lasted. Assistance through local institutions, however, besides being more cost-effective, is more likely to reflect a long-term support to the factories given that the institutions should provide the tools and resources to support the local industry. (J.1.1.01)

72. The rapid succession of fashion changes, the high added value in the fashion industry, the cost and the quality-conscious attitude of the increasingly affluent consumers in both industrialized and developing countries, have led to the development of sophisticated production techniques, all based on the extensive application of computers. The technologies are expensive and, while they require less manpower to operate, that manpower has to be highly skilled. The developing countries have the disadvantage of limited resources for capital investment, a generally higher share and cost of loan capital than in industrialized countries, less skilled labour and, usually, greater distances from the affluent market-place - all factors that hamper a quick response. Despite these drawbacks, the developing countries have no choice but to modernize their industry along the lines of the industrialized countries. The problem of isolation from the market-place can be overcome by establishing fashion centres in developing countries and providing the centres with efficient marketing links with firms in industrialized countries and by applying modern communication techniques more fully.

73. As in the previous year, in the food industry special emphasis was placed on product standardization and quality control, which called for the establishment of relevant facilities and the provision of expertise. In that context, two laboratories were established at the Thai Standards Institute combined with an industrial extension service. Assistance was provided to improve quality in grape and wine production as well as fruit juice processing sectors in Albania, Argentina, Bolivia and Romania. Quality control laboratories and pilot plant facilities were set up in Egypt and Sri Lanka and similar facilities became operational in China in the field of food additive production and application. 5/ As part of the technical rehabilitation and modernization programme, the renovation of the Kicolo Mill in Angola was completed: with a capacity of 200 tons/day, the mill meets the requirements for bread in Luanda city. 6/

74. Other activities included the setting up and organization of model schemes to demonstrate through improved technologies the production of better quality goods in demand in the market. In that context, special attention was paid to the participation of women in the production process particularly in connection with training and skill development. A small-scale coconut processing model scheme was established in Western Samoa involving seven private enterprises leading to higher production outputs of improved quality coconut oil. Small-scale cassava processing operations were upgraded in Sierra Leone. A karite butter production model scheme under establishment in Guinea was especially designed so as to take into account the development of women's skills and so were the project operations for the processing of fruit and vegetable dehydration in Senegal. In the food product and process R and D sector new malting techniques were under development in Ghana to convert sorghum instead of imported barley malt for use in the beer-brewing process. Research continues for the improvement of the karkadeh powder production technology in the Sudan, and a research programme has begun for the Asian region for the production of cheese from coconut milk. (J.1.1.02)

75. Technical assistance in the animal-based food industry, an activity linked to the food industry sector, is playing an increasingly important role through an integrated approach covering all stages and all inputs required from different agro-industrial sectors. Progress was achieved in the modernization of the fish industry in Morocco and Viet Nam involving nets and boats, upgrading of landing facilities, fish processing, conservation and utilization of by-products. Innovative approaches in UNIDO technical co-operation projects led to such diversification of goods as dairy baby food, fish and liquid food products and animal feed additives in Mongolia 7/ and Viet Nam. (J.1.1.05)

76. Other highlights of the year were the mobilization of the available marine resources and full utilization of animal and fish wastes and by-products for human consumption as well as for animal feed, and the elaboration of ecologically clean technology. These new trends in technical co-operation were reflected in the global Expert Group Meeting on Industrial Ecologically Clean Crop Production Systems in Artificial Climate, that was held in Moscow, Union of Soviet Socialist Republics in September 1990 and in the Pacific region, including Micronesia. (J.1.1.04)

5/ Ibid., para. 70.

6/ Ibid., para. 71.

7/ IOB.5/10, chap. II, para. 66.

**Table 1**  
**Technical co-operation expenditure, by source of funds**

	1 9 9 0	
	\$ thousand	%
UNIDO regular budget		
Regular programme of technical co-operation	2,523	1.6
Industrial Development Decade for Africa	1,966	1.2
Subtotal	4,489	2.8
UNDP		
IPF and cash counterpart	88,667	55.6
SIS	5,218	3.3
Special programme resources and special measures	0	
Subtotal	94,330	59.1
UNDP-administered trust funds	1,716	1.1
Other funds		
Other trust funds	25,726	16.1
Industrial Development Fund	27,909	17.5
UNFDAC	2,146	1.3
Non-UNIDO funds	3,242	2.0
Subtotal	59,023	37.0
T O T A L	159,558	100.0

**Table 2**  
**Technical co-operation expenditure, by project component**

	1 9 9 0	
	\$ thousand	%
Project personnel	68,830	43.1
Subcontracts	20,575	12.9
Fellowships and training	23,215	14.5
Equipment	42,367	26.6
Miscellaneous	4,571	2.9
T O T A L	159,558	100.0



Table 3

Technical co-operation expenditure in Africa, a/  
by source of funds

	1 9 9 0	
	\$ thousand	%
UNIDO regular budget		
Regular programme of technical co-operation	1,022	1.8
Industrial Development Decade for Africa	1,897	3.4
Subtotal	2,919	5.2
UNDP		
IPF and cash counterpart	31,732	57.0
SIS	2,585	4.6
Special programme resources and special measures	0	0.0
Subtotal	34,317	61.6
UNDP-administered trust funds	245	0.4
Other funds		
Other trust funds	8,412	15.1
Industrial Development Fund	8,092	14.5
UNFDAC	801	1.4
Non-UNIDO funds	895	1.6
Subtotal	18,200	32.7
T O T A L	55,681	100.0

a/ Including African Arab States (Algeria, Djibouti, Egypt, Libyan Arab Jamahiriya, Morocco, Somalia, Sudan, Tunisia).

Table 4

Technical co-operation expenditure in Africa, a/  
by project component

	1 9 9 0	
	\$ thousand	%
Project personnel	27,008	48.5
Subcontracts	8,189	14.7
Fellowships and training	4,602	8.3
Equipment	14,043	25.2
Miscellaneous	1,839	3.3
T O T A L	55,681	100.0

a/ Including African Arab States (Algeria, Djibouti, Egypt, Libyan Arab Jamahiriya, Morocco, Somalia, Sudan, Tunisia).

**Table 5**  
**Technical co-operation expenditure in Arab States.**  
**by source of funds**

	1990 a/		1990 b/	
	\$ thousand	%	\$ thousand	%
<b>UNIDO regular budget</b>				
Regular programme of technical co-operation	131	0.6	117	0.8
Industrial Development Decade for Africa				
Subtotal	711	3.3	644	4.3
	842	3.9	761	5.1
<b>UNDP</b>				
IPF and cash counterpart	11,702	54.2	6,380	43.0
SIS	470	2.2	380	2.6
Special programme resources and special measures	160	0.7	0	0.0
Subtotal	12,332	57.1	6,760	45.6
<b>UNDP-administered trust funds</b>	0	0.0	0	0.0
<b>Other funds</b>				
Other trust funds	6,016	27.9	5,952	40.2
Industrial Development Fund	1,079	5.0	568	3.8
UNFDAC	698	3.2	345	2.3
Non-UNIDO funds	631	2.9	438	3.0
Subtotal	8,424	39.0	7,303	49.3
<b>T O T A L</b>	<b>21,598</b>	<b>100.0</b>	<b>14,824</b>	<b>100.0</b>

a/ Including African Arab States (Algeria, Djibouti, Egypt, Libyan Arab Jamahiriya, Morocco, Somalia, Sudan, Tunisia).

b/ African Arab States only.

**Table 6**  
**Technical co-operation expenditure in Arab States.**  
**by project component**

	1990 a/		1990 b/	
	\$ thousand	%	\$ thousand	%
Project personnel	11,961	55.4	7,794	52.6
Subcontracts	2,823	13.1	2,513	17.0
Fellowships and training	1,374	6.4	722	4.9
Equipment	4,923	22.8	3,373	22.8
Miscellaneous	517	2.4	422	2.8
<b>T O T A L</b>	<b>21,598</b>	<b>100.0</b>	<b>14,824</b>	<b>100.0</b>

a/ Including African Arab States (Algeria, Djibouti, Egypt, Libyan Arab Jamahiriya, Morocco, Somalia, Sudan, Tunisia).

b/ African Arab States only.

**Table 7**  
**Technical co-operation expenditure in Asia and the Pacific,**  
**by source of funds**

	1 9 9 0	
	\$ thousand	%
UNIDO regular budget		
Regular programme of technical co-operation	624	1.3
Industrial Development Decade for Africa	0	0.0
Subtotal	624	1.3
UNDP		
IPF and cash counterpart	41,685	84.4
SIS	896	1.8
Special programme resources and special measures	285	0.6
Subtotal	42,866	86.8
UNDP-administered trust funds	72	0.1
Other funds		
Other trust funds	1,230	2.5
Industrial Development Fund	2,703	5.5
UNFDAC	68	0.1
Non-UNIDO funds	1,821	3.7
Subtotal	5,822	11.8
T O T A L	49,384	100.0

**Table 8**  
**Technical co-operation expenditure in Asia and the Pacific,**  
**by project component**

	1 9 9 0	
	\$ thousand	%
Project personnel	14,794	30.0
Subcontracts	6,043	12.2
Fellowships and training	9,533	19.3
Equipment	18,103	36.7
Miscellaneous	911	1.8
T O T A L	49,384	100.0

**Table 9**  
Technical co-operation expenditure in Europe,  
by source of funds

	1 9 9 0	
	\$ thousand	%
UNIDO regular budget		
Regular programme of technical co-operation	83	1.6
Industrial Development Decade for Africa	0	0.0
Subtotal	83	1.6
UNDP		
IPF and cash counterpart	3,044	58.1
SIS	667	12.7
Special programme resources and special measures	0	0.0
Subtotal	3,711	70.9
UNDP-administered trust funds	0	0.0
Other funds		
Other trust funds	361	6.9
Industrial Development Fund	139	2.7
UNFDAC	938	17.9
Non-UNIDO funds	4	0.1
Subtotal	1,442	27.5
T O T A L	5,236	100.0

**Table 10**  
Technical co-operation expenditure in Europe,  
by project component

	1 9 9 0	
	\$ thousand	%
Project personnel	1,105	21.1
Subcontracts	411	7.8
Fellowships and training	1,307	25.0
Equipment	2,325	44.4
Miscellaneous	88	1.7
T O T A L	5,236	100.0

**Table 11**  
**Technical co-operation expenditure in Latin America and the Caribbean,**  
**by source of funds**

	1 9 9 0	
	\$ thousand	%
UNIDO regular budget		
Regular programme of technical co-operation	290	2.6
Industrial Development Decade for Africa	0	0.0
Subtotal	290	2.6
UNDP		
IPF and cash counterpart	6,884	61.4
SIS	980	8.7
Special programme resources and special measures	0	0.0
Subtotal	7,864	70.2
UNDP-administered trust funds	0	0.0
Other funds		
Other trust funds	627	5.6
Industrial Development Fund	2,130	19.0
UNFDAC	(14)	(0.1)
Non-UNIDO funds	306	2.7
Subtotal	3,049	27.2
T O T A L	11,203	100.0

**Table 12**  
**Technical co-operation expenditure in Latin America and the Caribbean,**  
**by project component**

	1 9 9 0	
	\$ thousand	%
Project personnel	7,377	65.8
Subcontracts	670	6.0
Fellowships and training	1,320	11.8
Equipment	1,512	13.5
Miscellaneous	324	2.9
T O T A L	11,203	100.0

Table 13

Number of technical co-operation projects under implementation in 1990  
by region, by field of activity and size of project

		Size of project						Subtotal	Total
		Africa	Arab States a/	Asia/Pacific	Europe	Latin America/Caribbean	Global/inter-regional		
Agro-based industries	(i)	18	8 (4)	16	3	16	9	66	152
	(ii)	27	8 (8)	25	1	10	4	67	
	(iii)	6	2 (2)	11	0	2	0	19	
Chemical industries	(i)	39	20 (11)	40	27	27	31	173	351
	(ii)	27	14 (11)	64	14	6	5	119	
	(iii)	14	9 (9)	41	1	1	2	59	
Metallurgical industries	(i)	16	7 (5)	19	8	9	10	64	120
	(ii)	10	2 (2)	17	6	3	1	38	
	(iii)	3	1 (1)	13	0	2	0	18	
Engineering industries	(i)	29	17 (8)	24	14	19	16	111	209
	(ii)	17	5 (5)	28	8	6	0	59	
	(iii)	9	2 (1)	26	1	1	1	39	
Industrial planning	(i)	26	4 (4)	11	3	12	15	67	115
	(ii)	20	5 (1)	5	1	6	0	36	
	(iii)	8	0 (0)	2	0	2	0	12	
Institutional infrastructure	(i)	33	8 (4)	18	5	25	9	94	271
	(ii)	45	15 (9)	19	7	13	5	95	
	(iii)	11	3 (0)	6	0	2	2	82	
Industrial management/rehabilitation	(i)	17	6 (5)	11	2	18	4	53	98
	(ii)	17	6 (4)	10	2	4	1	36	
	(iii)	2	2 (1)	5	0	1	0	9	

a/ Figures in parentheses relate to African Arab States and are already included under Africa.

Table 13 (continued)

Number of technical co-operation projects under implementation in 1990  
by region, by field of activity and size of project

		Size of project						Subtotal	Total
		Africa	Arab States <sup>a/</sup>	Asia/ Pacific	Europe	Latin America/ Caribbean	Global/ inter- regional		
Feasibility studies	(i)	36	15 (9)	15	4	7	10	78	
	(ii)	19	11 (5)	6	0	0	4	35	
	(iii)	3	2 (0)	1	0	0	1	7	120
Industrial human resource development	(i)	16	5 (1)	9	9	6	69	113	
	(ii)	9	2 (2)	1	2	0	15	27	
	(iii)	1	0 (0)	0	0	0	0	1	141
Other <sup>b/</sup>	(i)	56	19 (6)	38	13	36	119	275	
	(ii)	20	6 (4)	17	4	8	40	91	
	(iii)	1	1 (1)	0	0	0	10	11	377
Total technical co-operation expenditure	(i)	286	109 (57)	201	88	175	292	1,094	
	(ii)	211	75 (51)	192	45	56	75	603	
	(iii)	58	22 (15)	105	2	11	16	199	1,896

<sup>a/</sup> Figures in parentheses relate to African Arab States and are already included under Africa.

<sup>b/</sup> See statistical annex, table 6, "Expenditure on technical co-operation activities in 1990, by Department/programme component and geographical area", for breakdown.

**Table 14**  
**Regional distribution of technical co-operation expenditure,**  
**by field of activity**

(Percentage)

	Africa	Arab States <sup>a/</sup>	Asia and the Pacific	Europe	Latin America and the Caribbean	Global/inter-regional	Total
Agro-based industries	45.0	7.4 (7.2)	43.3	0.2	8.7	2.6	100
Chemical industries	35.6	25.4 (24.5)	50.8	4.3	3.4	5.0	100
Metallurgical industries	25.4	6.7 (6.1)	58.4	4.7	4.1	6.8	100
Engineering industries	39.0	10.6 (8.5)	33.1	5.0	5.5	15.3	100
Industrial planning	61.6	12.2 (1.6)	18.3	0.6	7.9	1.0	100
Institutional infrastructure	38.8	15.2 (3.2)	22.8	3.0	15.1	8.3	100
Industrial management and rehabilitation	46.5	17.0 (12.0)	32.0	1.6	14.2	0.7	100
Feasibility studies	48.4	31.6 (8.8)	12.9	0.8	2.9	12.2	100
Industrial human resource development	29.1	4.1 (1.4)	5.7	5.4	3.0	54.1	100
Other <sup>b/</sup>	11.7	4.6 (2.4)	9.6	3.9	6.3	66.3	100
<b>Total technical co-operation expenditure</b>	<b>34.9</b>	<b>13.5 (9.3)</b>	<b>31.0</b>	<b>3.3</b>	<b>7.0</b>	<b>19.6</b>	<b>100</b>

<sup>a/</sup> Figures in parentheses relate to African Arab States and are already included under Africa.

<sup>b/</sup> See statistical annex, table 6, "Expenditure on technical co-operation activities in 1990, by Department/programme component and geographical area", for breakdown.



**Table 15**  
**Number of technical co-operation projects by branch/programme element**

Branch and programme element code	(1) Projects in progress at 31.12.1990			(2) Projects approved in 1990 a/	(3) Outputs completed in 1990
	INTERCOUNTRY	INT/GLO	COUNTRY b/		
<b>Agro-based Industries</b>					
J.1.1.01	-	-	26 (16)	10	11
J.1.1.02	1	4	28 (21)	11	12
J.1.1.03	10	1	33 (24)	11	17
J.1.1.04	-	1	2 (2)	2	5
J.1.1.05	-	-	7 (4)	1	1
<b>Total J.1.1.</b>	<b>11</b>	<b>6</b>	<b>96 (49)</b>	<b>35</b>	<b>46</b>
<b>Chemical Industries</b>					
J.1.2.01	1	1	20 (14)	4	4
J.1.2.02	3	7	56 (20)	25	21
J.1.2.03	-	-	7 (5)	2	2
J.1.2.04	6	2	52 (26)	20	22
J.1.2.05	1	3	14 (10)	7	3
J.1.2.06	1	3	21 (15)	9	9
J.1.2.07	-	2	3 (3)	1	3
J.1.2.08	1	4	19 (14)	6	3
J.1.2.09	-	-	6 (5)	-	2
J.1.2.10	2	9	41 (25)	15	17
J.1.2.11	1	-	-	-	-
<b>Total J.1.2.</b>	<b>16</b>	<b>31</b>	<b>239 (65)</b>	<b>89</b>	<b>86</b>
<b>Metallurgical Industries</b>					
J.1.3.01	-	2	13 (8)	6	5
J.1.3.02	2	1	16 (14)	8	10
J.1.3.03	1	1	19 (14)	10	6
J.1.3.04	-	-	14 (10)	1	-
J.1.3.05	-	-	12 (8)	7	2
J.1.3.06	2	2	5 (4)	4	2
J.1.3.07	-	2	3 (2)	5	-
<b>Total J.1.3.</b>	<b>5</b>	<b>8</b>	<b>82 (37)</b>	<b>41</b>	<b>25</b>
<b>Engineering Industries</b>					
J.1.4.01	3	2	27 (18)	13	9
J.1.4.02	-	-	27 (18)	9	13
J.1.4.03	1	-	2 (2)	-	-
J.1.4.04	3	4	21 (12)	9	8
J.1.4.05	-	-	4 (4)	1	1
J.1.4.06	1	2	17 (14)	10	6
J.1.4.07	4	-	10 (8)	6	6
J.1.4.08	3	-	7 (5)	4	2
J.1.4.09	1	-	8 (7)	2	3
<b>Total J.1.4.</b>	<b>16</b>	<b>8</b>	<b>123 (48)</b>	<b>54</b>	<b>48</b>

Table 15 (continued)

Branch and programme element code	(1) Projects in progress at 31.12.1990			(2) Projects approved in 1990 <sup>a/</sup>	(3) Outputs completed in 1990
	INTERCOUNTRY	INT/GLO	COUNTRY <sup>b/</sup>		
<b>Industrial Planning</b>					
J.2.1.01	4	10	41 (27)	22	21
J.2.1.02	<u>2</u>	<u>1</u>	<u>24 (10)</u>	<u>11</u>	<u>12</u>
Total J.2.1.	6	11	65 (36)	33	33
<b>Institutional Infrastructure</b>					
J.2.2.01	1	1	15 (13)	5	4
J.2.2.02	1	1	30 (26)	15	10
J.2.2.03	2	6	51 (38)	29	20
J.2.2.04	3	1	8 (7)	4	3
J.2.2.05	1	1	15 (12)	1	6
J.2.2.06	<u>4</u>	<u>3</u>	<u>24 (16)</u>	<u>15</u>	<u>9</u>
Total J.2.2.	12	13	143 (71)	69	52
<b>Industrial Management and Rehabilitation</b>					
J.2.3.01	2	-	20 (17)	9	4
J.2.3.02	-	-	23 (11)	10	5
J.2.3.03	1	-	4 (3)	-	3
J.2.3.04	<u>3</u>	<u>3</u>	<u>26 (20)</u>	<u>14</u>	<u>8</u>
Total J.2.3.	6	3	73 (45)	33	20
<b>Feasibility Studies</b>					
J.3.1.01	1	5	24 (18)	25	11
J.3.1.02	5	1	28 (21)	8	13
J.3.1.03	-	1	-	1	-
J.3.1.04	<u>2</u>	<u>3</u>	<u>12 (11)</u>	<u>19</u>	<u>9</u>
Total J.3.1.	8	10	64 (42)	53	33
<b>Industrial Human Resource Development</b>					
J.3.2.01	4	1	7 (7)	9	3
J.3.2.02	-	-	-	-	<sup>c/</sup>
J.3.2.03	-	-	-	-	<sup>d/</sup>
J.3.2.04	-	1	-	-	2

<sup>a/</sup> All the projects included in column (2) are not necessarily reflected in column (1), particularly in the case of approvals made late in the year.

<sup>b/</sup> Numbers in parentheses indicate the number of countries with country projects in progress.

<sup>c/</sup> For number of fellowships see appendix I, table 4.

<sup>d/</sup> For number of group training programmes see appendix I, tables 1 and 2.

**TECHNICAL CO-OPERATION PROJECT EXPENDITURES  
BY PROJECT COMPONENT, 1976-1990**  
(in thousands of US dollars)

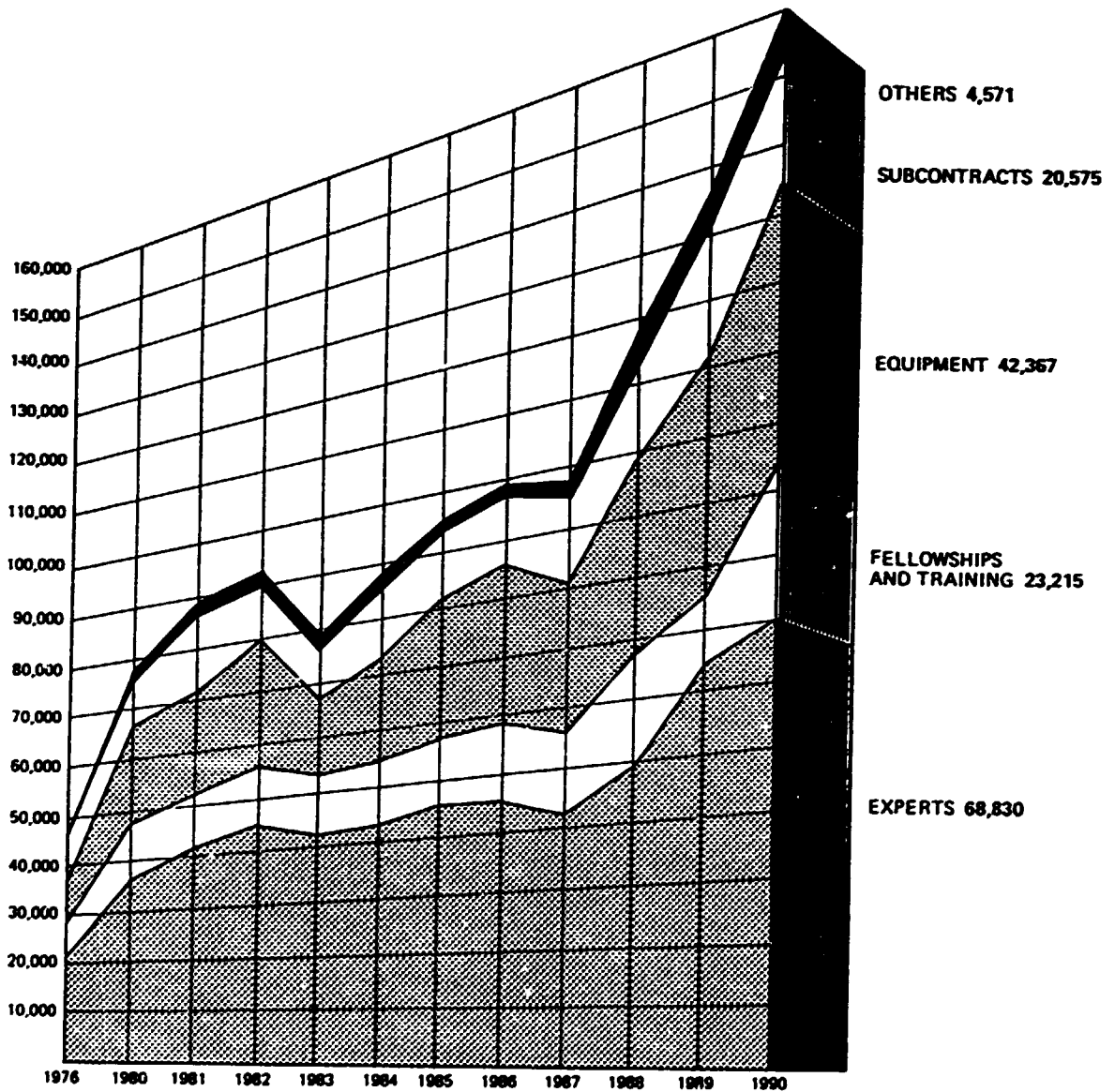

**TECHNICAL ASSISTANCE DELIVERED BY UNIDO IN 1990**  
 (by geographical area, in millions of US dollars and percentages)

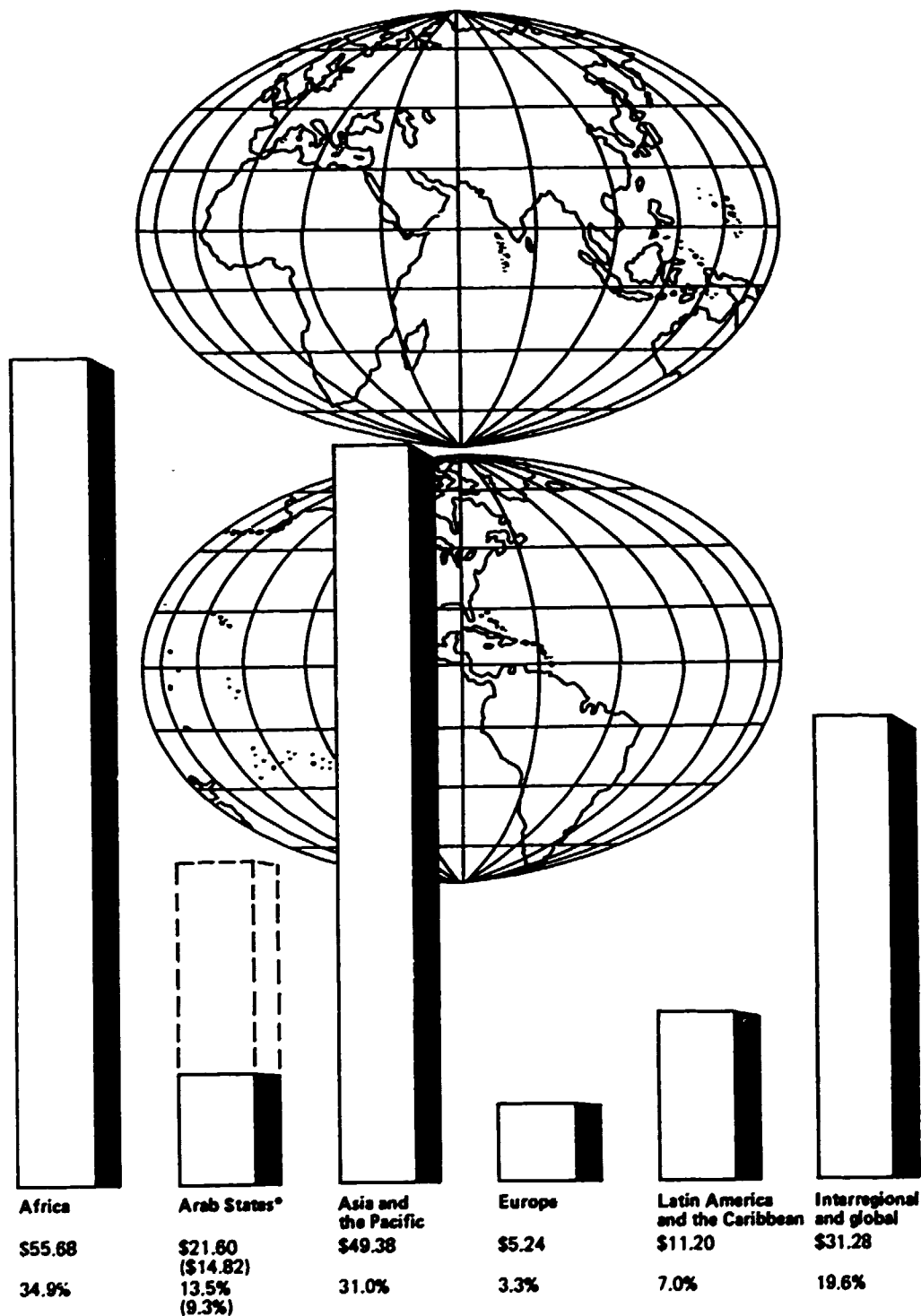

\*Broken lines and figures in parentheses give an indication of the African Arab States which are also included under the column "Africa".

**TECHNICAL ASSISTANCE DELIVERED BY UNIDO IN 1990**  
(in millions of US dollars)

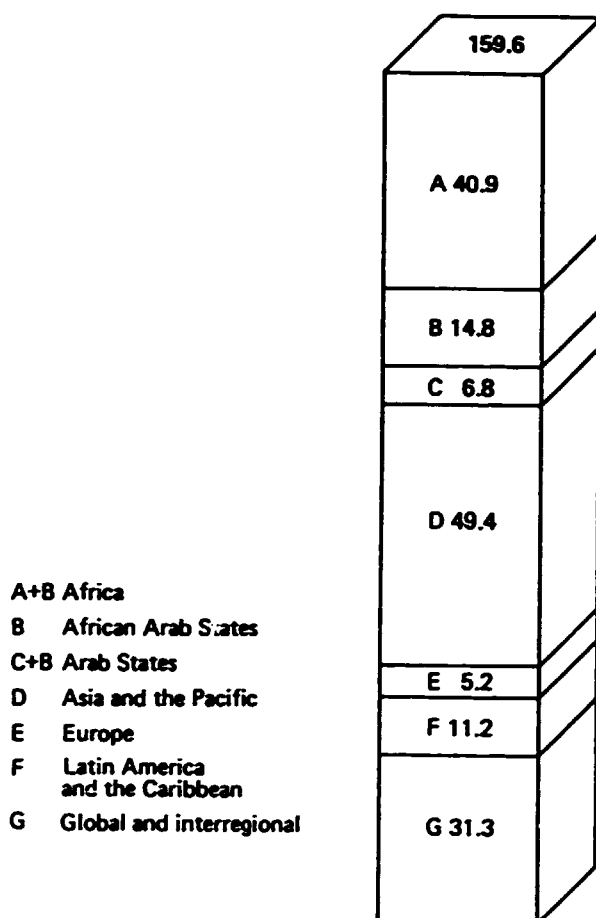

**DISTRIBUTION OF TECHNICAL CO-OPERATION ACTIVITIES IN 1990**  
(in millions of US dollars)

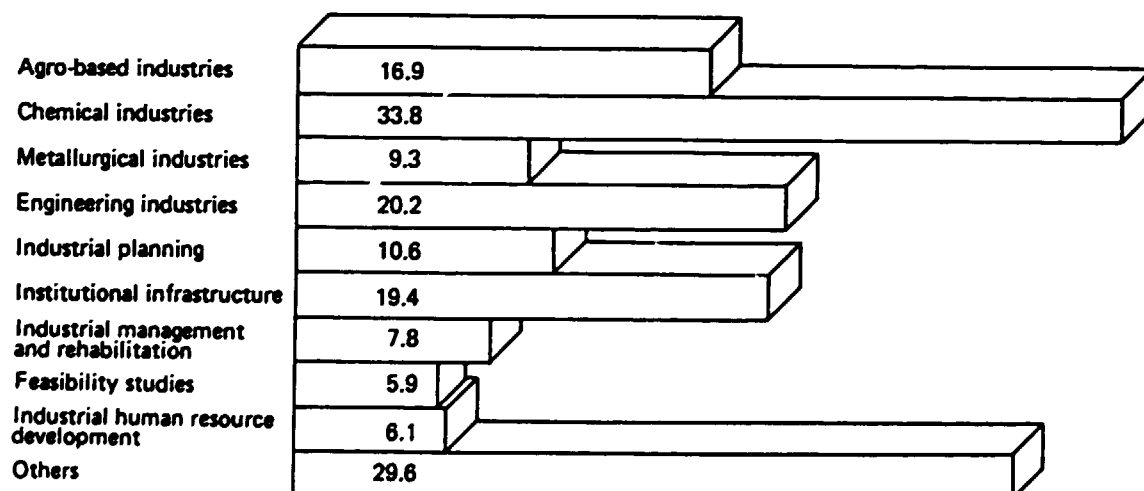

# AFRICA

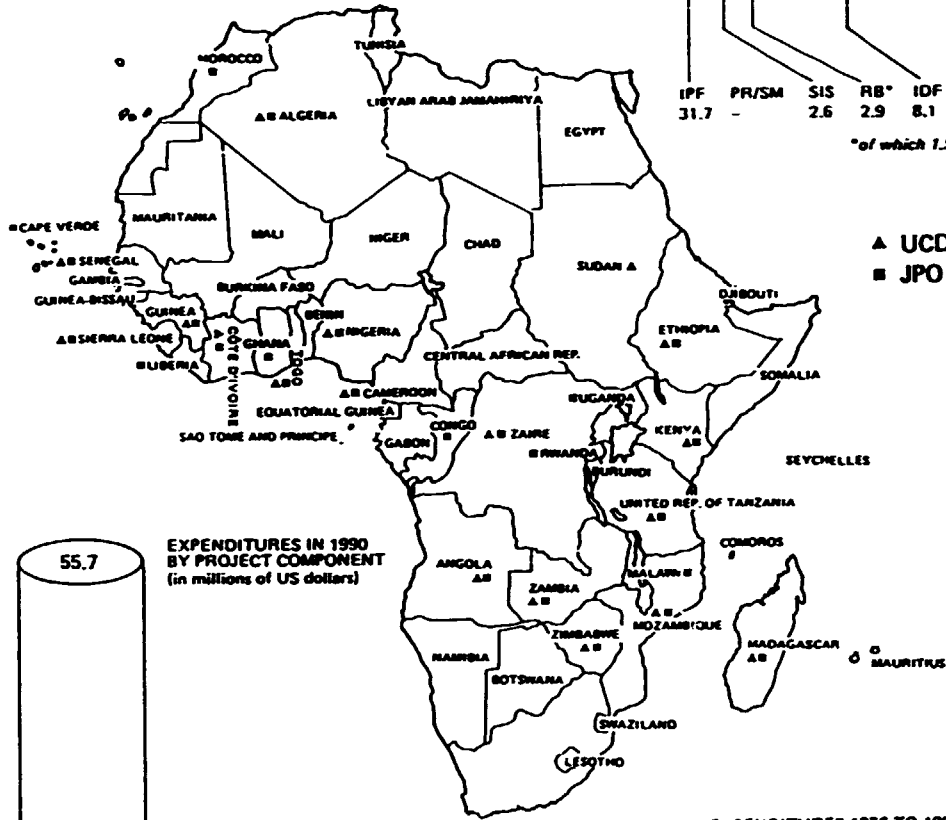

EXPENDITURES IN 1990 BY SOURCE OF FUNDS  
(in millions of US dollars)  
55.7

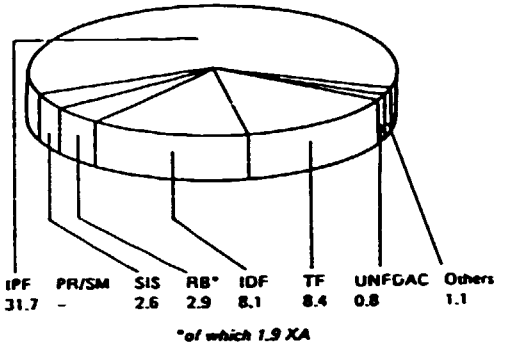

▲ UCD duty station  
■ JPO duty station

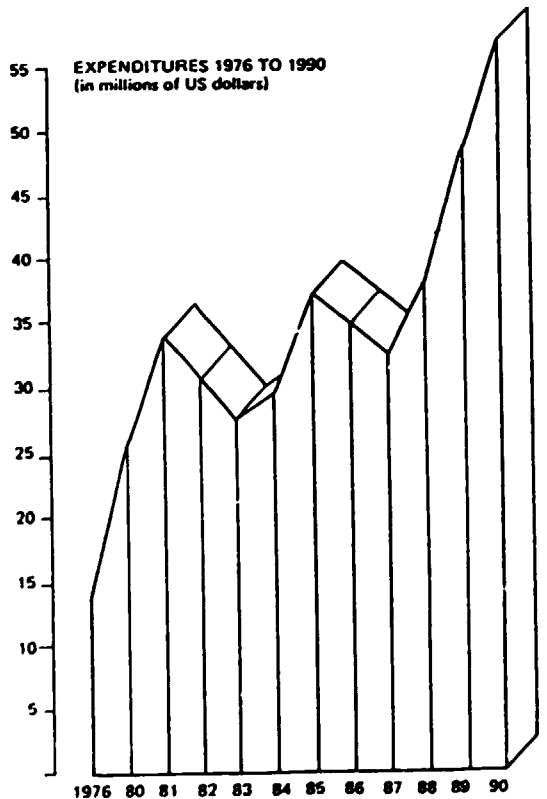
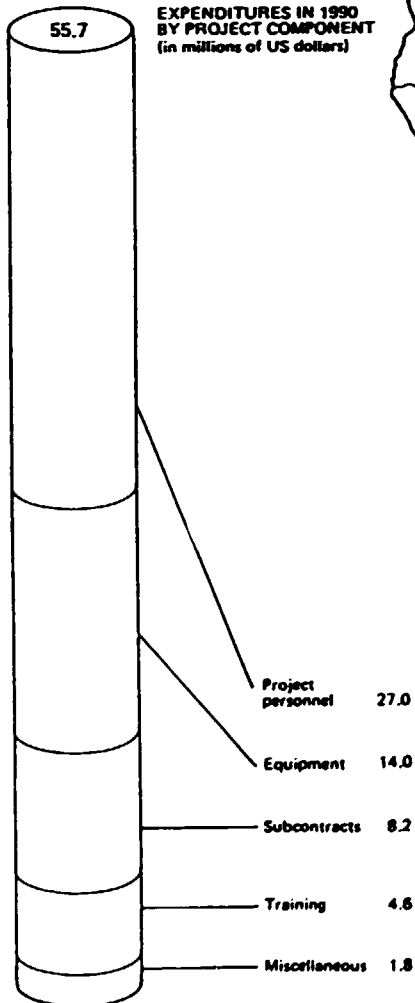

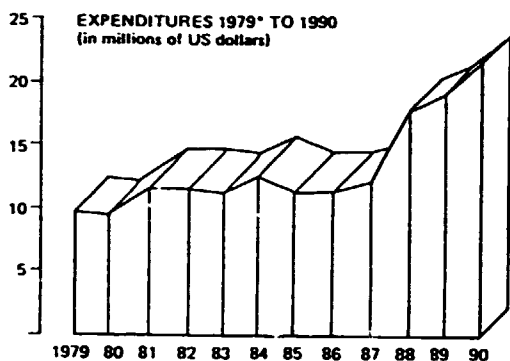

\*For previous years, expenditures related to Arab States were reported partly under Africa and partly under Europe and Western Asia.

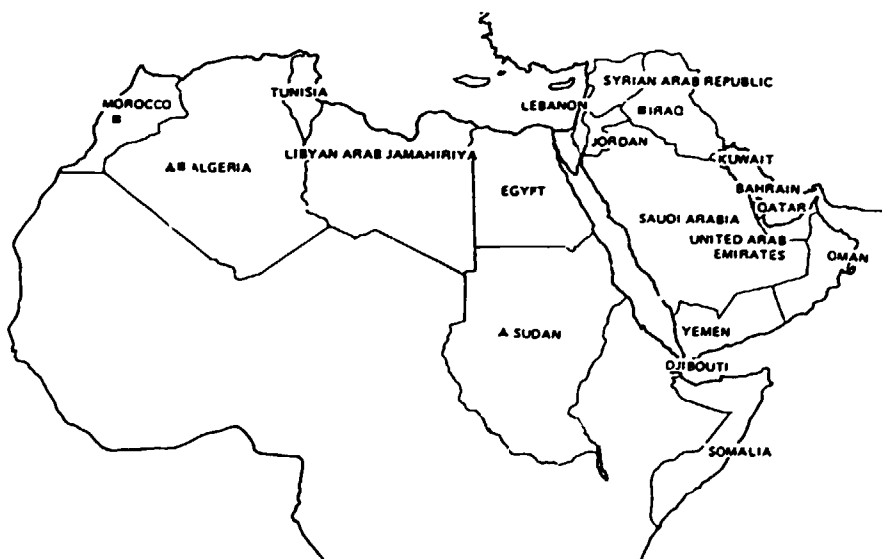
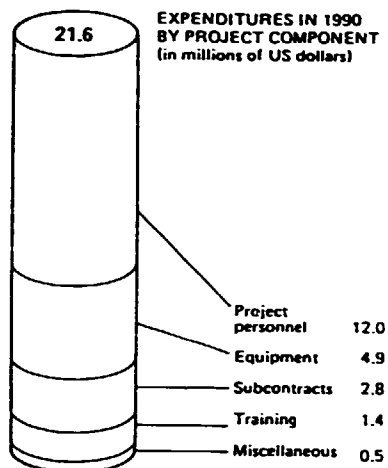

## ARAB STATES

**EXPENDITURES IN 1990 BY SOURCE OF FUNDS**  
(in millions of US dollars)

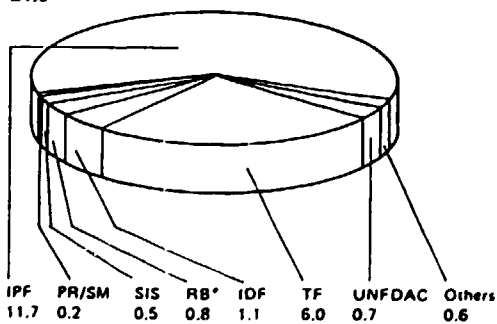

\*of which 0.7 XA

▲ UCD duty station  
■ JPO duty station

# ASIA AND THE PACIFIC

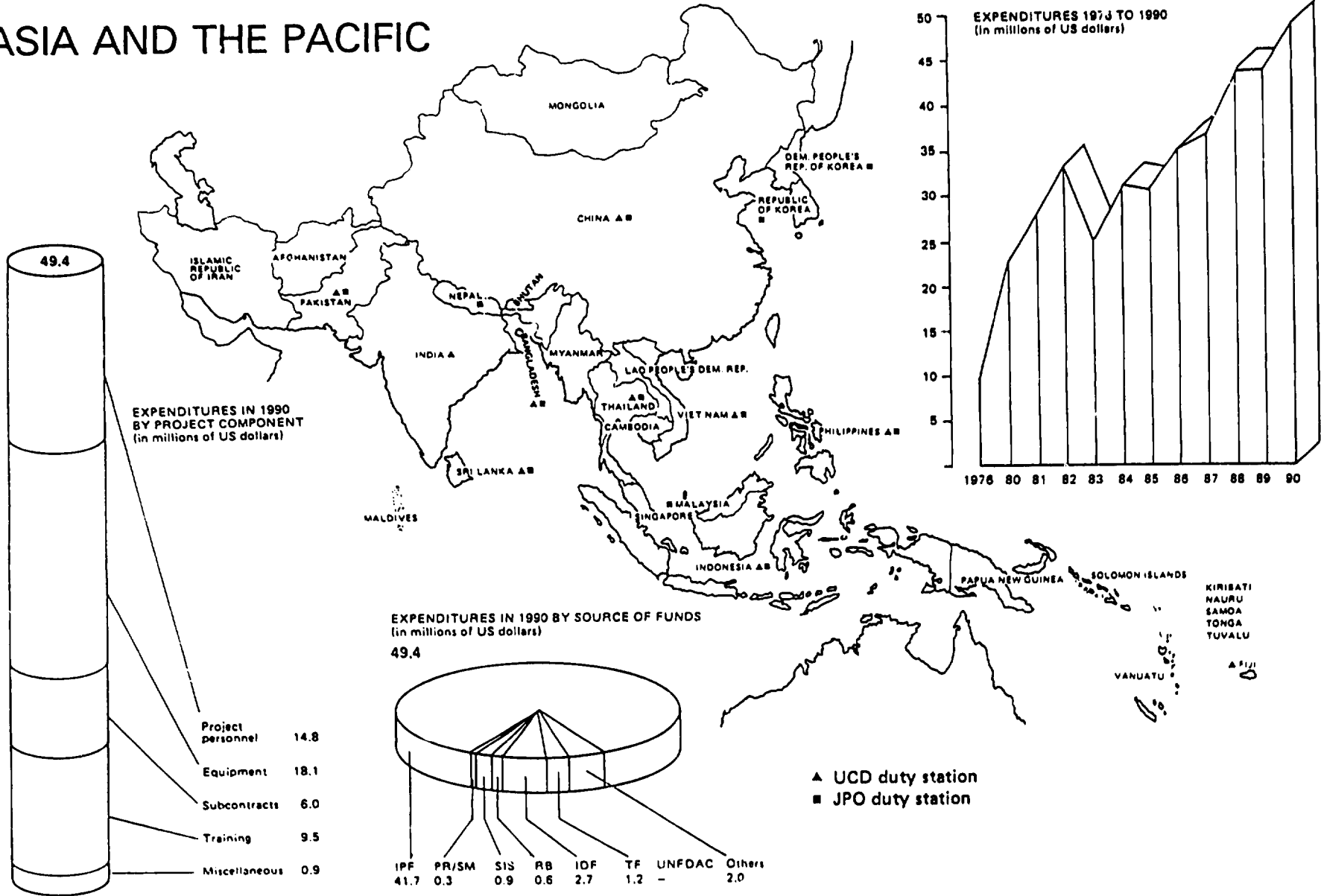



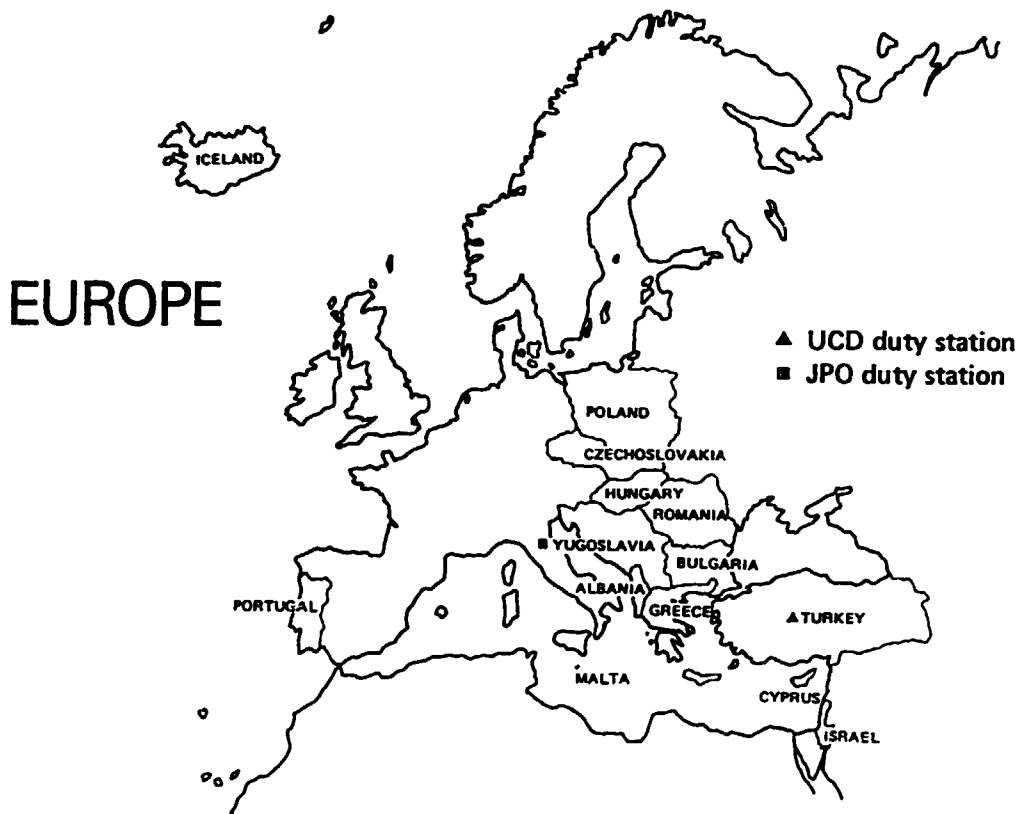

**EXPENDITURES IN 1990 BY PROJECT COMPONENT**  
(in millions of US dollars)

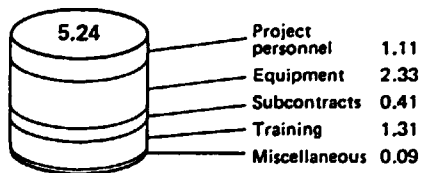

**EXPENDITURES IN 1990 BY SOURCE OF FUNDS**  
(in millions of US dollars)

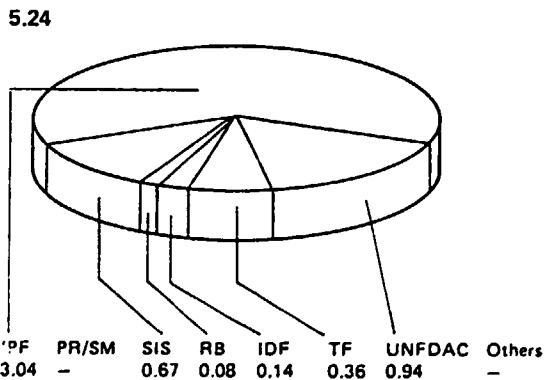

**EXPENDITURES 1976 TO 1990**  
(in millions of US dollars)

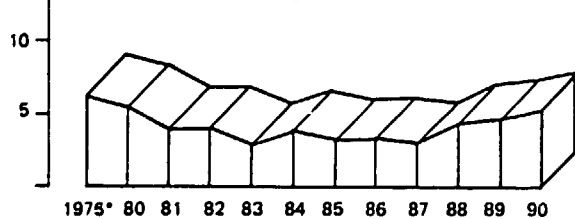

\*The figure for 1976 combines Europe and Western Asia and includes 12 countries which, since 1979, are listed under Arab States.

# LATIN AMERICA AND THE CARIBBEAN

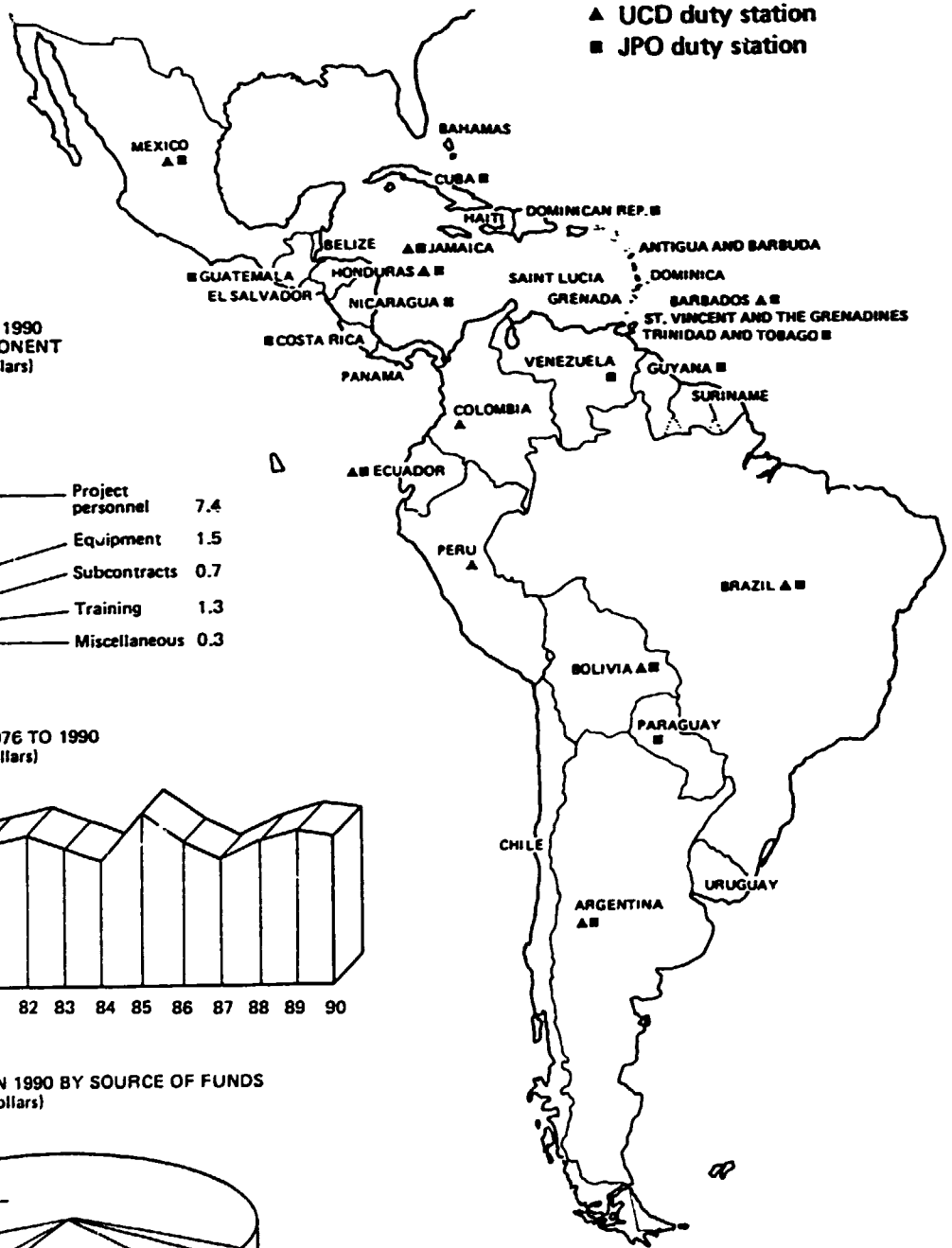

EXPENDITURES IN 1990 BY PROJECT COMPONENT (in millions of US dollars)

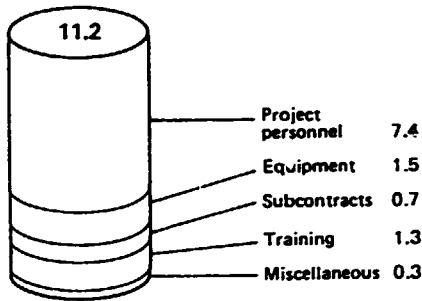

EXPENDITURES 1976 TO 1990 (in millions of US dollars)

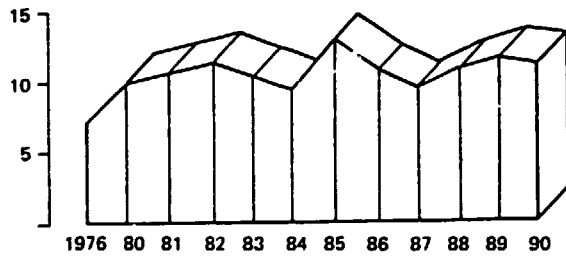

EXPENDITURES IN 1990 BY SOURCE OF FUNDS (in millions of US dollars)

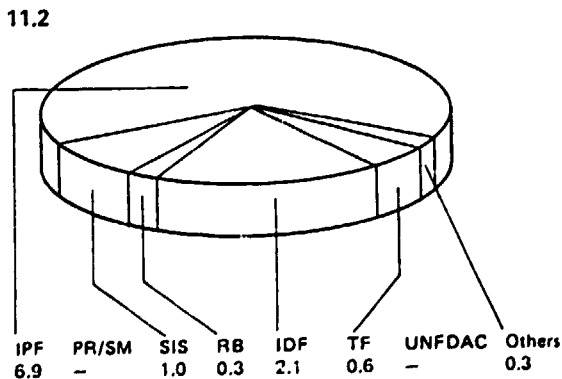

77. The main activity in the leather and leather products industry sector continued to be the implementation of the large-scale improvement scheme for hides and skins, leather and leather products in the African region. The programme, which covers eight countries, has been well established and results have started to emerge. For example, a major Ethiopian shoe factory was successfully rehabilitated and the productivity is expected to double. The rehabilitation of some private and public tanneries in Ethiopia, Kenya, United Republic of Tanzania, Zambia and Zimbabwe has reached an advanced stage. Good progress was made in activities relating to the hides and skins improvement carried out jointly by the Food and Agriculture Organization of the United Nations and UNIDO in the countries participating in the scheme.

78. Pollution control and environmental problems, a key issue in the leather industry, were addressed with emphasis on assistance to small-scale industries for which environmental control investments are high and difficult to bear. Facilities of pilot, demonstration and product development centres were upgraded in Africa, 8/ Asia and Latin America. For example, designing and shoemaking equipment was installed in the Hyderabad Leather Footwear Centre in Pakistan and is now serving the local small-scale industry sector. Encouraging results were achieved in integrating women in the activities of the Centre through the recruitment of female students in every training course and the employment at the Centre of two female instructors. At the Development Centre for Rubber Technology in Myanmar, equipment was installed for the physical/chemical laboratory, the moulded rubber pilot plant and the workshop. (J.1.1.03)

## CHEMICAL INDUSTRIES

79. Technical co-operation expenditures under the heading of chemical industries (J.1.2) amounted to \$33.7 million. Some 67 per cent of the total implementation was financed from UNDP resources. A total of 351 projects were implemented or under implementation.

80. During the reporting period particular attention was taken to ensure that technical co-operation projects had a favourable impact on the environment, contributed to energy conservation, and took into account the other priority areas in the medium-term plan for the period 1990-1995 (GC.3/17). While some projects were primarily designed to reduce pollution and encourage recycling, others combined reduction of pollution with energy saving. For example, the outcome of projects for the lubricating oil industry was a

decreased use of lubricating oils and a much lower production of waste oils; in the paint industry projects resulted in decreased use and emission of volatile organic compounds; assistance in polyurethane development led to a reduction in the use of chlorofluorocarbons; projects promoting non-fired bricks and blocks such as stabilized soil blocks helped to reduce the amount of firewood expended; projects in non-metallic minerals contributed towards environmentally sound mining practices. Through technical co-operation in chemical and process engineering design capabilities, several countries could enhance their ability to develop their own chemical industry while reducing pollution and improving the efficiency of existing industries.

81. Technical co-operation among developing countries (TCDC) became an important feature of the chemical industries programme, with experts from developing countries being used in many projects particularly in the cement industry, the development of ceramic technologies and the chemical processing of vegetable oils. Human resource development was an important component of projects for chemical engineering process design, of workshops dealing with maintenance, plant inspection and energy conservation in the petroleum refining industry and of programmes on man-made fibres and plastics technology. Assistance in the chemical process design is an essential prerequisite for the maintenance, rehabilitation and development of the chemical industry. Though much of the chemical industry is only viable on a large scale, industries using chemicals (such as the plastics transformation industry) and those using vegetable resources (such as charcoal production and essential oils production) are predominantly small- and medium-scale industries.

82. Requests continued to be received for assistance to the cement industry in developing countries, under UNDP financing or trust fund arrangements. Technical co-operation covered the full range of support activities from promotion of new factories through human resource development in China and the Islamic Republic of Iran to traditional projects focusing on training, energy conservation and pollution abatement in Bolivia and selected countries of the Preferential Trade Area for Eastern and Southern African States (PTA) as well as outright capacity utilization projects under trust fund arrangements in Egypt, Libyan Arab Jamahiriya, Nigeria and Yemen. 9/ Although UNIDO is promoting the establishment of small, energy-saving lime plants e.g. in Botswana, Gambia, Sao Tome and Principe, Togo, and United Republic of Tanzania, that industry is still lagging behind in development and no drastic changes were

8/ IDB.6/10, chap. II, para. 73.

9/ Ibid., para. 77.

achieved in transforming traditional fuel-intensive methods. (J.1.2.01)

83. Owing to price increases for petroleum and its derivatives and their impact on the economies of developing countries, technical co-operation in the field of petroleum refineries and petrochemical industries reached a peak and consisted of development and adaptation of modern technologies, efficient use of energy, rehabilitation or optimization of existing plants, development of human resources and environmental protection. These types of technical co-operation are found in activities related to: development of catalysts, chemical reagents, motor oils and lubricants, increasing the competitiveness of natural rubber *vis-à-vis* synthetics and recycling of plastics waste. In the field of carbon fibres and composites, projects are under implementation in China, the Republic of Korea and Romania. 10/ China has expressed interest in working together with other countries in that area. Another project in China 10/ for the production of artificial limbs using advanced materials was nearly completed and ways of expanding it in South Asia are being examined. A new area of transfer of technology began with the introduction of petrochemical engineering process design through projects in Viet Nam and Pakistan. The project on synthetic fibres in Pakistan 11/ is still ongoing and a similar one began in the Islamic Republic of Iran; co-operation is being established between the two projects and a large-scale project already completed in China. New projects on manufacturing plastics, paints and detergents are under implementation in China and Viet Nam. A global project began on the development of truck tyre retreading compounds, using natural rubber as its base, in an effort to increase the competitiveness of natural rubber *vis-à-vis* synthetic materials. In India, several projects dealing with characterization, manufacturing and evaluation of catalysts used in petroleum refining and petrochemicals were implemented with successful results. 12/ Concerning human resource development a workshop on maintenance, plant inspection and energy conservation in petroleum refineries was held in Japan and two in-plant group training programmes - on man-made fibres and plastics technology - were held in Austria. Owing to their environmental impact, the recycling of plastics has been a major problem for developing and developed countries. As a result of an ongoing project in China, preparations began for an international conference on plastics waste recycling technology scheduled for 1991. (J.1.2.02)

84. The market situation for fertilizers which, to a great extent, is influenced by the price of petroleum has created a new trend to rehabilitate existing, but non-profitable, fertilizer plants. Requests for assistance in the improvement and full capacity utilization of existing plants are increasing, and what is more, the need to set up mini-fertilizer plants in developing countries has become a reality. Priority was given to promoting the use of local raw materials for nitrogen, phosphate and potassium fertilizers to meet agricultural needs. 13/ In an effort to apply a systematic approach to the development of the fertilizer industry in Africa, UNIDO issued a publication entitled "Industrial Development Strategies for Fertilizer Industrial Systems in Africa". Co-operation continued with the World Bank, the Food and Agriculture Organization of the United Nations and the Economic and Social Commission for Asia and the Pacific which took the form of an exchange of information on, and discussion of topics of common interest in the fertilizer industry with inputs available especially from Europe and Asia. (J.1.2.03)

85. Growing awareness in developing countries of the need to improve health patterns on the one hand, and the lack of funds to import pharmaceutical products on the other, has resulted in increased requests to assess the feasibility of establishing new pharmaceutical production units, as well as rehabilitating and diversifying existing units. Technical assistance offered in 1990 focused on the production of synthetic pharmaceutical products through fermentation and biotechnology, biologicals and derived products, medicinal plants and essential oils. In the pharmaceutical and allied industries, the production of specialized chemical reagents in Viet Nam was successful in enhancing their self-reliance in the quality control of pharmaceutical products. 14/ Two new projects began in China for upgrading enzyme and penicillin productions. Both projects aim at improving the technical qualifications of staff and the quality of products, as well as increasing process yields and upgrading economic performance. Biotechnology programmes have progressed in Poland, Tunisia and Turkey 14/ for the utilization of local raw materials in valuable food and in pharmaceutical products. The ongoing Latin American regional project 14/ was successfully engaged in various industrial enzyme processes. Assistance was given to Senegal to establish a research programme in biomedical- and agro-industries by studying the possibilities of transforming their natural raw materials into high value added products. In Algeria, a modern pilot plant for the development and

10/ *Ibid.*, para. 82.

11/ *Ibid.*, para. 83.

12/ *Ibid.*, para. 85.

13/ *Ibid.*, para. 86.

14/ *Ibid.*, para. 87.

production of intravenous infusions is under construction. A micro-plant for the development of technology and training of personnel in applying fermentation techniques for the production of antibiotics was successfully completed in Cuba. 15/ In the Islamic Republic of Iran 14/ steady progress continued on the civil construction and installation works of the pharmaceutical chemicals pilot plant which will be ready for operation by the end of 1991. UNIDO assistance was given to the Soviet Republic of Armenia in the preparation of an integrated study in setting up a plant for the production of disposable syringes.

86. In the field of biologicals, as a result of a breakthrough, a new approach was developed for the production of human vaccines in veterinary units which are already available in many developing countries. Within the framework of the Industrial Development Decade for Africa, production of two tetanus toxoid vaccine batches of international standard was successful during the trial manufacturing period of the pilot plant in Cameroon, which was also supported by the strengthening of the Laboratoire National Vétérinaire of Garoua. 16/ The plant which was to be inaugurated in January 1991 opens up possibilities of increasing the availability of vaccines in developing countries. In the framework of a project in Mongolia, 17/ UNIDO has initiated the production of an enzyme final product with the co-operation of French companies. Similarly, a project was initiated in Viet Nam to introduce modern biochemical separation techniques for the manufacture of bioactive substances using available raw materials from animal organs. In the area of chemical technology of medicinal plants/essential oils, a project was launched in India to improve fragrances prepared with traditional processing equipment. In Sri Lanka, the capability of the Ceylon Institute of Scientific and Industrial Research was enhanced to improve R and D and to carry out extensive processing of essential oils to generate downstream products for perfumes and fragrance material. The clove oil distillery in the United Republic of Tanzania 18/ was rehabilitated to maximize its performance. In the Democratic People's Republic of Korea UNIDO experts initiated processes to eliminate dependence on imported resins and to minimize capital investment for the processing of stevia leaves. Another project was under way to produce essential oils and fragrance materials from *Rosa rugosa* and other

species. 19/ Two projects in Viet Nam 18/ have become models for successful project management by UNIDO on medicinal and aromatic plants, with research and development capabilities strengthened both at the Institute of Materia Medica and the Centre National de Recherches Scientifiques. (J.1.2.04)

87. In the area of pulp and paper UNIDO continued to assist a pilot plant facility in India to develop the application of the ferrite process in the chemical recovery of non-wood black liquor. The know-how in desilication of bamboo/reed black liquor acquired with UNIDO/Swedish support at the Central Pulp and Paper Research Institute of India 19/ was used to assist a pulp and paper mill in Turkey. In the Philippines, a pilot plant was installed to study the utilization of indigenous non-wood fibres in non-woven productions. In October, an International Seminar on Newsprint Production from Bagasse was organized in Cuba to disseminate information on Cuban technology and to discuss the existing technology in that field. A fully-fledged rehabilitation programme for a Nigerian pulp and paper mill was prepared for submission to the Government. 19/ A regional programme was initiated for the development of human resources and research capabilities in pulp and paper research institutes in China, India, Indonesia, Myanmar, Philippines and Thailand. (J.1.2.05)

88. Projects related to new and renewable energy sources, particularly the use of biomass and agricultural wastes, methane generation from organic wastes, and the monitoring/control of atmospheric emissions arising from the use of coal increased steadily throughout 1990. A Workshop on Biomass Thermal Processing Projects organized by UNIDO and the British Institute of Energy was held in the United Kingdom with the aim of developing project proposals on biomass energy based on South-South co-operation. Projects in biogas production from industrial wastes, financed by special-purpose contributions, were continued or developed. In China, a biogas plant to produce methane gas fuel and organic fertilizer from distillery waste was under construction and is scheduled for completion in 1991. Concerning fuel for domestic consumption, UNIDO experts provided technical advice to Viet Nam on briquetting anthracite coal for use in stoves, in place of wood fuel, as a measure of reducing deforestation. Also at the domestic level, UNIDO continued to assist Sudan with the manufacture of charcoal fuel briquettes made from waste cotton stalks. In the area of biotechnology, projects dealt mainly with chemical production by fermentation, and in bio-reactor design for fermentation and waste water treatment processes. New

15/ *Ibid.*, para. 88.

16/ *Ibid.*, para. 89.

17/ *Ibid.*, para. 88.

18/ *Ibid.*, para. 90.

19/ *Ibid.*, para. 91.

projects in environmental biotechnology (microbial pesticides, mineral bioleaching) are also being developed. (J.1.2.06)

89. Environmental awareness and the related issue of energy has become a priority concern of developing countries, demonstrated by the number of requests received for a range of environmentally linked activities in the field of non-metallic minerals (see para. 92 below). Examples are energy auditing of existing ceramic kilns carried out in China, Sri Lanka <sup>20/</sup> and Yugoslavia, which have led to appreciable savings of fuel. Energy efficient and environmentally sound designs of glass furnaces were also developed in China for use by the domestic flat glass industry and introduced in Viet Nam for experimental borosilicate glass production. Waste management of fly ash was the focus of a workshop at Shanghai, China, that offered technologies to other developing countries, developed previously in co-operation with UNIDO. Four projects, one funded by a special-purpose donation, were implemented in the area of waste water treatment while two other projects provided assistance in industrial/environmental planning on a regional basis. Several promising new projects were developed in those areas, and the potential for attracting special-purpose donations for these is high. UNIDO is assisting Utility Authorities at Kosovo, Yugoslavia, with a programme to monitor and control emissions from lignite-based power generation. (J.1.2.07)

90. Following recent accidents in the manufacturing of pesticides (e.g. at Bhopal, India) the development of environment-friendly pesticides was considered crucial in order to ensure continued investment in an industry that is a major contributor to the economies of developing countries. One approach is to develop technologies with reduced toxic materials and wastes; in that context UNIDO assisted Hungary in developing four promising non-toxic insect anti-agents. Companies in the industrialized countries are showing interest in developing these compounds. In Poland, <sup>21/</sup> UNIDO is providing high-level technical co-operation to develop pesticide mixture formulations and also to assist effluent control measures in the manufacture of herbicides. In China, the establishment of the bio-assay laboratories was successfully completed and, to mark the occasion, UNIDO organized at Shenyang in October an International Seminar on Recent Developments in the Field of Pesticides and their Application to Pest Control in China and other Developing Countries of the Region. The aim of the seminar was to promote North-South collaboration in the development of pesticides. There has been

a strong response to the Regional Network on Pesticides for Asia and the Pacific (RENAP) <sup>22/</sup> with the participation of the Islamic Republic of Iran, Malaysia and Myanmar in the network. The Indian Government has offered to finance the establishment of a permanent RENAP secretariat at New Delhi. The network has already established technical co-ordinator units with emphasis on quality, safety, environment protection and promotion of bio-botanical pesticides. UNIDO co-operated with the International Union of Pure and Applied Chemistry to assist developing countries to participate in a Workshop on Safety in Chemical Production held at Basel, Switzerland, in September. (J.1.2.08)

91. Concerning basic inorganic industries and salt production, technical co-operation was provided to Egypt and Nigeria in the production of basic salts. (J.1.2.09)

92. A breakthrough was reached in the area of non-metallic minerals, a resource found in many developing countries. Ten years of promotional activities and infrastructure-building developed within the framework of the Joint UNIDO/Czechoslovakia Committee for Co-operation have been officially recognized by China as an efficient and synergetic strategy. Six projects in China, covering a variety of technological aspects, have benefited considerably from management co-ordination and an exchange of information and technologies among the national institutions concerned. In Africa, the low-cost building materials programme progressed towards regional integration. Small-scale technologies for the manufacture of stabilized soil blocks and fibro-cement roofing tiles, already introduced, for instance, in Chad and Madagascar, <sup>23/</sup> were presented to interested entrepreneurs. Ten production units were established and their technical staff trained on the spot. Other countries, including Cameroon and the Congo, have expressed interest in following this example. Development of advanced ceramic technologies carried out inter alia in Hungary, India, Romania, Turkey and Yugoslavia took on a new dimension when leading scientists from industrialized and developing countries, and directors of UNIDO projects, met at Ankara, Turkey, to discuss a strategy for adopting such technologies in developing countries to ensure that the development of these technologies are integrated with user industries. With that perspective in mind, the idea of a network of co-operation was accepted by the participants. (J.1.2.10)

93. The development of new materials has had a significant impact on the industrial progress of developing countries and is a

<sup>20/</sup> *Ibid.*, para. 79.

<sup>21/</sup> *Ibid.*, para. 93.

<sup>22/</sup> IOB.4/10, chap. II, para. 74; IOB.5/10, chap. II, para. 88; IOB.6/10, chap. II, para. 93.

<sup>23/</sup> IOB.6/10, chap. II, para. 78.

key issue for future activities. Project concepts on new materials for electronic and solar devices were submitted to 25 developing countries in Africa, Asia and the Pacific, and Latin America and are currently under consideration. A paper was prepared on New materials for electronic and solar devices (IO.51/SPEC.) that presents ongoing and future UNIDO activities. (J.1.2.11)

## METALLURGICAL INDUSTRIES

94. In 1990, technical co-operation expenditures under the heading of metallurgical industries (J.1.3) amounted to \$9.3 million. Some 81 per cent of the total implementation was financed from UNDP resources. A total of 120 projects were implemented or under implementation.

95. The elaboration of new programmes and reorientation of activities towards the changing requirements of the metallurgical industry in developing countries were the main trends during the year under review. In the decades of the 1960s and 1970s many developing countries made heavy investments in the metallurgical industries which today require rehabilitation, taking into account the energy and environmental aspects as well as the need for product diversification and the application of new technologies. The new trends are reflected in the areas of spare parts production, computer applications, industrial mineral processing and testing, waste management and utilization as well as recycling techniques; these constituted the thrust of technical co-operation provided by UNIDO. In that context, the development of new materials was identified as an important element having a strong impact on the overall development of the metallurgical industry in the years to come. The development and promotion of new projects was pursued intensively in a wide range of technological fields and was supported by human resource development efforts through various technical workshops and seminars. Among the environmentally oriented projects that were promoted was a subregional workshop on low-waste technologies and pollution abatement in metallurgical industries.

96. In the field of non-ferrous metals, amorphous silicon solar cells were developed and produced by the Indian Association for the Cultivation of Science, Calcutta, with UNDP/UNIDO assistance. The solar cells produced gave an efficiency rate of above 12 per cent, comparable to those produced in Europe, Japan, and the United States of America. Assistance given to set up the Jawaharlal Nehru Aluminium Research, Development and Design Centre at Nagpur, 24/ was aimed at accelerating the growth of the Indian aluminium industry so as to meet the domestic demand; contacts

with the local industry were established to ensure commercial viability. Progress continued on the establishment of the tin ore laboratory in Viet Nam, 24/ with the installation of most of the equipment and the organization of the training programme. (J.1.3.01)

97. In iron and steel, the production of new materials and introduction of environmentally sound technologies was further emphasized. A sponge iron pilot plant was commissioned in Viet Nam 25/ with technical co-operation from India; in that plant a unique methodology is applied by which anthracite coal is used as a fuel and reducing agent. In Africa, technical co-operation was provided to small- and medium-scale rolling mills in PTA countries such as Kenya, Mauritius, Mozambique and the United Republic of Tanzania to rehabilitate and strengthen their operations. 26/ This included a training programme of plant managers in computerized modelling software for the evaluation of financial investments in modernization programmes, developed by the World Bank and modified in the United Kingdom for African conditions. Through assistance provided with Austrian funds to the Rolmill Kenya Ltd. productivity increased by 30 per cent as did the reduction in energy consumption. With special-purpose contributions from Japan, projects were initiated in Hungary to improve the efficiency of steel plants, and to promote pollution abatement at the pilot project level. (J.1.3.02)

98. Many projects in the foundry sector aimed at identifying and satisfying the demands for consumers of spare parts and introducing new and more appropriate cost-effective manufacturing technologies. The most obvious example is the fourth project in an eight-year series in Paraguay, with its strong TCDC component involving assistance from Brazil, which is serving as a model for other subsectors in Paraguay. Assistance to the TAKSAN foundry plant in Turkey has led, in its first stage, to significant operational cost savings; it has also included advice for considerable capital investment. In Sri Lanka, assistance in the production of grinding balls and other products is expected to lead to profitable operations and thus revive the country's only steel foundry. In Viet Nam the large-scale foundry project recently initiated at the Research Institute for Technology and Machinery 27/ provides vital assistance to the foundry and heat treatment activities required for the reactivation of the industry. In an effort to increase the participation of women in industry, UNIDO identified two

25/ IOB.4/10, chap. II, para. 87; IOB.5/10, chap. II, para. 95.

26/ IOB.6/10, chap. II, para. 99.

27/ Ibid., para. 101.

24/ IOB.6/10, chap. II, para. 98.

women experts who assisted in foundry and related activities in Mongolia, Pakistan and Viet Nam. (J.1.3.03)

99. Assistance continued for the establishment and strengthening of centres for metallurgical technology and corrosion protection, e.g. at the National Metallurgical Development Centre in Nigeria. 28/ At the Non-Ferrous and Rare Earths Research Institute, Beijing, China, the pilot plant was inaugurated and work started on copper-phosphorus brazing alloys and solders used in the production of electronic equipment, while at the Research Institute for Electric Light Source Materials, Nanjing, China the pilot plant for tungsten wire drawing was commissioned and research work began on tungsten wires for filaments. 28/ (J.1.3.04)

100. Some projects also dealt with the industrial processes for ore and mineral beneficiation and waste utilization. Work continued on the pilot plant for mineral processing and laboratories for bacterial leaching and X-ray spectroscopy installed at the Centre for Mineral and Metallurgical Research in Cuba. 29/ In Hungary, 30/ new technologies were established for the industrial utilization of metallurgical wastes, e.g. slags, dust, red mud as well as fly ash from thermal power plants. Several developing countries expressed interest in these new technologies. In India a start was made for developing technologies for the utilization of blue dust and kimberlite waste material. (J.1.3.05)

101. Rationalization and computerization of systems for production processes, maintenance and related fields in metallurgical industries was provided at national and regional levels. In Algeria, 31/ an integrated system for production control and maintenance management was developed using local area network computers; it was supported by training in the development of advanced computer software. A European regional project on computerized management systems in metallurgical and other basic industries has developed a comprehensive project network; in that context a Euro-Arab workshop on computerized maintenance management systems was convened for seven Arab countries, with the support of the Joint UNIDO-Czechoslovakia Programme for International Co-operation in Metallic Industries. 32/ A similar project was

launched, based on multi-user personal computer configurations, for selected steel plants in the ASEAN region. (J.1.3.06)

102. Computer applications contributed to the improved utilization of resources - human, financial and information - and created the necessary preconditions for the introduction and development of new advanced metals and materials. In Mexico, in the electronic industries, the possibilities for the production of soft and hard ferrites were identified. In Yugoslavia, assistance was extended to cover the production of gallium 33/ and of special steels modified by calcium, titanium and niobium. Comprehensive training programmes for the application of titanium technology were carried out in China, Egypt and in the Union of Soviet Socialist Republics. These new cleaner technologies also contribute to the solution of pressing environmental problems. (J.1.3.07)

## ENGINEERING INDUSTRIES

103. Technical co-operation expenditures under the heading of engineering industries (J.1.4) amounted to \$20.2 million. About 78 per cent of the total implementation was financed from UNDP resources. A total of 209 projects were implemented or under implementation.

104. During the reporting period, emphasis was given to the development of multi-disciplinary engineering activities of a problem-solving nature. A firm base was established in that respect by paying special attention to the five priority problem areas and the three elements common to industrial development identified in the medium-term plan, 1990-1995 (GC.3/17). In addition, assistance and advice in the implementation of complex projects contributed to promote the development of new and innovative approaches to technical co-operation problems, and to facilitate technical co-operation among developing countries. Main areas of technical co-operation continued to be: the application of appropriate techniques to rural industrialization; integration of electro-mechanical and electronic aspects in subsectoral development; metal works and machine tools; transport equipment; development of equipment in the energy sector; advancement of manufacturing value added through process technology and packaging techniques; repair and maintenance; and the introduction and application of advanced technologies. 34/

105. The scope and application of metal-working and machine tools in varying degrees of technology sophistication in

28/ IDB.5/10, chap. II, para. 98; IDB.6/10, chap. II, para. 103.

29/ IDB.6/10, chap. II, para. 102.

30/ IDB.5/10, chap. II, para. 100.

31/ IDB.3/10, chap. II, para. 60; IDB.6/10, chap. II, para. 100.

32/ IDB.6/10, chap. II, para. 100.

33/ IDB.5/10, chap. II, para. 95; IDB.6/10, chap. II, para. 99.

34/ IDB.6/10, chap. II, para. 106.



different countries continued to be major technical co-operation activities, covering product, plant and technical institutional levels. 35/ Emphasis was placed on improving utilization of installed industrial capacity through diversification of the product mix and improving product quality while reducing the cost through the progressive introduction of numerically controlled machine tools and high quality tools. Activities related to preventive maintenance and repair of machinery and equipment enjoyed increasing interest in developing countries. In that area, the introduction of computer-controlled scheduling for maintenance and computer-supported inventory control systems for spare parts, as well as reconditioning of worn parts and components through metal-spraying technologies received considerable attention, and so helped to reduce unexpected breakdowns and to extend the life-span of capital-intensive equipment. Examples of such activities took place: at the institutional level in China, Ethiopia, India, Indonesia, Kenya, Trinidad and Tobago, and in an African regional project; at the plant level in China; and at the product level in Chile and China. Examples of some specialized activities are: extended application of computer-aided design/computer-aided manufacturing (CAD/CAM) techniques in the manufacture of dies and fine blanking techniques in China and the manufacture of moulds for plastic articles in Tunisia. 36/ (J.1.4.01 and J.1.4.02)

106. As regards rural equipment, special attention was paid to agricultural tools and implements including manually- and animal-drawn equipment, storage and post-harvest technology, intermediate power equipment, rural transport equipment, water pumps and windmill pumping systems. The emphasis was placed on development, manufacture, repair and maintenance and marketing. The major objective was to enhance the quality of life in the rural sector, to contribute in improving agriculture, to maintain equipment service systems and, above all, to provide suitable tools and implements that are within the purchasing capacity of farmers with small- and medium-size holdings. 37/ Project proposals continued to be based on an integrated approach to the development of agricultural machinery and related sectors of the economy while fully utilizing existing facilities and installed capacities. The following are examples of such activities. A revised study was prepared for the manufacture of agricultural and farm equipment for the factory at Soroti, Uganda. 37/ In the area of design and prototype a project financed under the Special Industrial Services programme was

completed in the United Republic of Tanzania for the manufacture of oil-seed presses, decorticating machines, threshers, planters and seeders. In Kenya the preparatory phase of a project was started which will assist rural artisans in the design and manufacture of simple agricultural tools and equipment by establishing rural agricultural engineering support centres throughout the country. Two projects were initiated to set up and or upgrade workshops for the repair and maintenance of agricultural equipment and transport vehicles intended for refugees of the national liberation movements, African National Congress and Pan Africanist Congress. (J.1.4.03)

107. Areas relating to high technology included: computer applications to industrial design, manufacturing, maintenance and automation; electronic components and equipment; medical equipment; environmental monitoring and control equipment; industrial process control and automation equipment and systems; high-precision components; and machine tools and equipment. Efforts were devoted to product design and prototyping using computerized reverse engineering techniques, production rationalization and automation. UNIDO also responded to the growing awareness of environmental problems by developing new concepts such as the preparation of pollution control guidebooks, application of noise engineering techniques, remote sensing and/or telemetering of environmental parameters, design/development and manufacturing of low-cost analytical instruments for pollution monitoring. A few examples of newly initiated projects on the application of high technology are the improvement of quality and reliability of electronic products through CAD/CAM techniques in India, Viet Nam, and at the regional level for Asia and the Pacific and for Africa; the introduction of flexible manufacturing systems in China; application of automation and process control in the Republic of Korea; and the development of electronic devices for waste water management in Bulgaria. (J.1.4.04, J.1.4.05 and J.1.4.06)

108. The technical co-operation programmes in the transport industry included land-based and water-borne equipment and covered a spectrum of products and components. Assistance provided to the diesel engine manufacturing plant in Bangladesh emphasized product diversification and testing. The locomotive diesel engine plant in China completed the first prototype, a computer- and processor-controlled diesel locomotive roller test stand was installed and testing techniques equal to international standards were introduced. 38/ Application of CAD/CAM Methods for Manufacturing of Railway Equipment was under implementation in Egypt. In Pakistan, the Vendor Development

35/ *Ibid.*, para. 110.

36/ *Ibid.*, para. 111.

37/ *Ibid.*, para. 107.

38/ *Ibid.*, para. 114.

and Training Cell was established to assist local entrepreneurs with manufacturing quality components and assembly parts: technical co-operation consisted of consulting services for factory "trouble shooting" and initial tool performance evaluation in the production environment. 38/ In the United Republic of Tanzania, assistance was provided to Tarsia Ltd. in upgrading the quality of locally manufactured leafsprings for trucks. An expert group meeting on control and regulatory measures concerning motor vehicle emissions in the Asia and Pacific region was held at Seoul, Republic of Korea, in August. The aim was to determine which areas are most feasible for regional co-operation and at what level a concerted approach should be taken to introduce emission and fuel quality standards in the Asia and Pacific region. (J.1.4.07)

109. The area of energy provided opportunities to promote practical and innovative concepts and actions, since equipment is required for non-renewable energy sources such as oil, hydropower and coal as well as for renewable sources such as solar, wind and biomass. Other requirements are instrumentation for energy control and conservation and environmental engineering. 39/ Examples of technical co-operation activities include the manufacture and installation of wind turbines in Egypt, inauguration of a small hydropower station in Madagascar, manufacture of solar water heaters in Sierra Leone, training in techniques aimed at improving the quality and reliability of electrical components in the Democratic People's Republic of Korea, and a laboratory for calorimetric and performance testing of airconditioners in China. A co-operative activity under a trust fund agreement with the Armenian General Benevolent Union in the Union of Soviet Socialist Republics deserves special mention. The activity involves the design and construction of a cold storage and meat packaging plant to replace a plant at Leninakan that was damaged by the 1988 earthquake (cf. chap. VIII, para. 27). The new seismic-resistant plant will be constructed with environmental considerations, by using ammonia instead of freon as the cooling agent and by applying design and material criteria for energy efficiency. (J.1.4.08)

110. Increased attention was given by developing countries to technology in packaging, aiming at quality, marketability and increased value added. It is expected that, as a result, agro-based industries and subsequently the entire ancillary industry will gain new impetus. Co-operation continued in this area with the International Trade Centre. 40/ (J.1.4.09)

111. Repair and maintenance, spare parts production and services on the one hand, and technical training of local personnel on the other, are integrated in all engineering industries projects. These two elements have helped to reduce idle capacity, to ensure fuller utilization of installed capacity and to improve the level of industrial activities, as evidenced in Barbados, Burkina Faso and Togo. 41/

## INDUSTRIAL PLANNING

112. In 1990, technical co-operation expenditures under the heading of industrial planning (J.2.1) amounted to \$10.6 million. Some 88 per cent were financed from UNDP resources as compared to 83 per cent in 1989. A total of 115 projects were implemented or are under implementation.

113. The year was characterized by further concentration on the approaches adopted in the previous biennium: (a) strategic management of the restructuring and development of the industrial sector; (b) enhancement of the productive performance of the industrial sector and subsectors; and (c) decision support systems for planning and policy formulation.

114. Concerning the strategic management of the restructuring and development of the industrial sector (J.2.1.01), the year saw further development of methods, building on the experience gained from ongoing projects 42/ (e.g. in Congo, Côte d'Ivoire, Guinea and Zaire) and the Regional Workshop on Strategic Management of the Adjustment Process in the Industrial Sector in Africa held in 1989. 42/ Work on method documentation continued. Industrial information - an essential aspect in the formulation of sound industrial strategies and policies - was emphasized during 1990. An expert group meeting was held in Vienna from 25 to 29 June, at which discussions were held on the current features of industrial information systems used in strategic management projects. Such systems (in use in Burkina Faso, Guinea, Niger, Senegal, Zaire and forthcoming in Congo and Rwanda) provide information on industrial activity through a range of indicators supplied for specific enterprises, as well as aggregated at subsectoral and sectoral levels. Periodic surveys allow for continuous updating. Future development aims at a closer integration of industrial strategies and policies into the strategic management approach, through the use of effective computer-aided support systems for decision-making in that field.

39/ *Ibid.*, para. 115.

40/ *Ibid.*, para. 116.

41/ *Ibid.*, para. 117.

42/ *Ibid.*, para. 120.

115. A project in Côte d'Ivoire serves as an illustration of the ongoing activities dealing with strategic management of restructuring and development of the industrial sector.<sup>42/</sup> An industrial master plan prepared by UNIDO for Côte d'Ivoire laid the foundation for an interactive development process that focused on ten priority subsectors. The Ivorian authorities subsequently called upon UNIDO to provide high-level advice on industrial strategies and policies for the selected subsectors; for each subsector, strategic consultative groups were set up in which industrialists and representatives from the concerned administration and relevant services participated. The tasks of the groups included: (a) in-depth diagnosis of the subsector; (b) identification of business opportunities and formulation of strategic plans; and (c) integrated action programmes encompassing investment programmes and industrial policy recommendations. The consultative process revealed essential features in the organization and functioning of the priority subsectors that will provide a basis for the formulation of effective and realistic development strategies.

116. In Malaysia, assistance was provided to review the industrial policy issues emanating from a UNDP/UNIDO project for an industrial master plan completed in 1985, and reconcile them with the Malaysian industrial policy studies recently carried out within a UNDP/World Bank project. The impact of the current industrial policies and policy measures on the progress and achievement of the Fifth Malaysia Plan is being assessed and certain policy parameters such as an effective rate of protection and domestic resources costs are being calculated and updated. Likewise, under another UNIDO project in the same country, a dynamic input-output model and industrial projections were being reviewed and updated in the context of the Sixth Malaysia Plan (1991-1995) formulated by the Government.

117. During the year, discussions were held at Washington D.C. and in Vienna on the relations and co-operation between the projects carried out under the UNIDO strategic management approach and the structural adjustment programmes of the World Bank. Agreement on co-operation at the project level was reached in several cases. Preparations began for workshops to be held in 1991 in which the World Bank and UNIDO will analyse problem areas and try to further increase co-operation between the two organizations.

118. In an innovative approach adopted by the Government of Cyprus, UNDP and UNIDO agreed to provide substantive involvement in monitoring the implementation of a government-executed project, aimed at strengthening the competitiveness of Cyprus industry. The task is to be carried out in consultation and co-operation with the Ministry of Commerce and Industry, the Government executing agency for the project. The agreement will ensure continuous

substantive guidance and inputs by UNIDO within the framework of the project in an aim to build up the Government's capability for strategic planning and management of the industrial sector. That capability will, in turn, strengthen the structure, efficiency and competitiveness of the Cypriot export market and, at the same time, motivate the private sector to achieve a greater role and participation in the industrial development and promotion process, particularly at the enterprise, plant and production levels.

119. Efforts continued to assist developing countries in sectoral and subsectoral planning and programming (J.2.1.02). For Latin America, a regional programme on industrial automation of capital goods industries was designed and formulated and negotiations with potential donors were under way. The objective of the regional programme is to stimulate the development of the capital goods industry in Latin American countries through a programmed introduction of strategic management, industrial automation technologies and quality management. With those goals in mind, a capacity will be built up with private sector counterparts to provide the necessary support and specialized professional services. Assistance will be extended to decision makers in private enterprises as well as in the public sector, with special emphasis on human resource development, management skills and know-how requirements. Within the framework of subsectoral programming, two sales publications were prepared and will be issued in 1991: "Planning and programming the introduction of CAD/CAM systems - A reference guide for developing countries" (IÜ/SER.0/1), and "Computer-integrated manufacturing - perspectives for international economic development and competitiveness". The latter was prepared in co-operation with the Economic Commission for Europe.

120. As part of UNIDO services to developing countries for improving and strengthening their capacity for strategic planning and management, the importance of decision support systems was emphasized. In January and March, two expert meetings were held within the programme for use of computer-aided tools in industrial planning (UNIDPLAN).<sup>43/</sup> The purpose of the meetings was to formulate a plan of action for future activities in the development and transfer of computer-aided planning tools, particularly in the area of integration of environmental aspects in industrial planning or strategic management. Work continued on tools to be applied in agro-industrial programming. Decision support tools and a linear programming model were introduced in four developing countries.

121. In the context of programme development support (see paras. 54-57 above) work

43/ Ibid., para. 124.

continued on method development and the application of a programme approach to identify support and co-operation requirements for industrial development. A revised and updated version was finalized of the software and documentation for the methodology for assessing and programming production/consumption systems (MEPS). Project proposals were developed for the integrated development of fisheries industrial systems in Namibia and Senegal, the development of an export-oriented agro-based industry in Ecuador, the oils and fats sector in Colombia and prospective plans for four industrial subsectors in Bulgaria.

## INSTITUTIONAL INFRASTRUCTURE

122. Technical co-operation expenditures under the heading of institutional infrastructure (J.2.2) amounted to \$19.4 million. Some 82.8 per cent of the total implementation was financed from UNDP resources. A total of 271 projects were implemented or under implementation.

123. The unprecedented level of technical co-operation delivery in 1990 reflects the growing demand from developing countries for UNIDO assistance, through multi-disciplinary programmes in: institutions and infrastructure for the promotion and development of small- and medium-scale industries; entrepreneurship development and privatization; rural industrial development; industrial research and development institutions and industrial information services; standardization, quality control and metrology; as well as for institutions promoting industrial development, including industrial subcontracting industrial associations and chambers of commerce and industry. The upward trend was also a direct result of the comprehensive integrated approach adopted for design and implementation of technical co-operation projects and the development of various innovative programmes which enhanced UNIDO's responsiveness to the increasingly sophisticated, varied and dynamically changing needs of the recipient countries.

124. Science and information have become vital components of any sustainable economy. UNIDO activities aimed at establishing and strengthening R and D institutions and technical information systems adequately reflect the significant changes occurring in the world, coupled with the beginning of the global information age. Thus projects in 1990 were characterized by the following considerations: fast and efficient commercialization of R and D, incorporation of information networks into enterprises as a catalytic factor for industrial performance, the role of high technologies, and the integrated approach to industrial activities from the viewpoint of optimization of life quality and minimization of industrial risk. In Egypt, an integrated information network was designed to

facilitate the integration of research activities of more than 15 R and D institutions reporting to the Ministry of Industry. In Guyana, a computerized multi-purpose system capable of providing services in appropriate accounting, technical information search and retrieval was established at the Institute of Applied Science and Technology. 44/ The purpose is to enable the Institute to gain access to global information networks via satellite and to use desktop publishing facilities to produce a technology-oriented newsletter for the needs of domestic industries. The Industrial Research Development and Training Centre in Malawi, by establishing its own in-house research and consulting capacities, is expected to become the first institution to provide substantial assistance to domestic industries in identifying appropriate national sources of knowledge and skills. 44/ In all three projects (Egypt, Guyana and Malawi), the close interrelation between research and information activities is a prerequisite for the fast growth and successful operations of the corresponding institutions. The role of new high technologies in the fields of human safety and medicine and their positive impact on the quality of life is evident in two projects undertaken in China and the Syrian Arab Republic. The Syrian project to set up the Centre for Optical Technologies in Damascus successfully reached its main objective, when the Centre was able to design and manufacture (in small batches) optical microscopes for medicine and education. It was the first example of such an undertaking in the Arab countries. 45/ A project on lasers for medicine in China assisted in the design and manufacture of solid-state lasers for surgery and ophthalmology, thus enabling national medical institutions to cope with major diseases. Humanization of the topics for R and D is also reflected in a successful project in Bulgaria, where the performance of the aluminium casting plant in Pleven was to be improved not only from the technological and economic point of view, but also taking into account environment and occupation factors. (J.2.2.01)

125. As described in the Annual Report, 1989 46/ UNIDO activities in quality control, standardization and metrology constitute an important element of the integrated programmes designed to provide assistance to industry, including small- and medium-scale industries. UNIDO continued to assist in establishing national systems and institutions by way of major projects in countries such as Algeria, China, Indonesia, Iraq, Malawi, Nepal, Saudi Arabia, Sri Lanka, Togo, Turkey, Viet Nam, Yemen and Zambia. It also assisted the African Regional Organization

44/ *Ibid.*, para. 128.

45/ IDB.5/10, chap. II, para. 132.

46/ IDB.6/10, chap. II, para. 129.

for Standardization in developing metrological activities in Africa. 46/ A project with the International Standards Organization (ISO) is helping to identify needs and opportunities for regional technical co-operation so as to establish viable institutions for national standards and strengthen existing networks. Another regional project for the ASEAN countries aims to identify regional co-operation in metrology. The concept of direct support to small- and medium-scale industries in relation to quality assurance, 46/ under which a selected institution provides training and advisory services to managers and staff, continued to be applied in practice. Projects were also being formulated that emphasize direct assistance to enterprises on total quality management, quality systems and quality improvement. (J.2.2.02)

126. Small- and medium-scale industries continued to represent a high priority area and was a major programme element. Technical co-operation was based on the integrated modular approach that provides a comprehensive package of services at the policy, institutional and enterprise levels aimed at overcoming constraints faced by those industries in access to resources and/or information. The basic constraints confronting such industries in bringing about effective improvements in productivity and quality are lack of modern management techniques, insufficient knowledge of markets and marketing strategies and low levels of process and product technology as well as difficult access to finance. A major area of assistance therefore to support those industries was the provision of industrial extension services to transmit managerial and technological advice and information. Such assistance took the form of individual counselling, information services, training and support activities in industrial research and was generally provided through the intermediation of national institutions for small- and medium-scale industries development and/or other support organizations such as industrial estates, common facility centres, and associations.

127. Small- and medium-scale enterprises often lack the required financial resources and technical expertise for marketing and promotion on the domestic and international levels. Therefore, there is a need for institutional support to devise appropriate strategies and schemes to assist in marketing. Such support enables access to market information and facilitates business contacts and promotion. Enterprise-to-enterprise co-operation programmes and national and international sub-contracting programmes have been instrumental in satisfying those needs and contributing to the modernization of the small- and medium-scale enterprise sector in several developing countries. The programme on enterprise-to-enterprise co-operation between small-scale industries in Italy and those in Argentina, Brazil and India already promoted 34 co-operation agreements

(14 in Argentina, 10 in Brazil, 10 in India) and the total investment generated was about \$35 million. 47/ The South-South co-operation project funded by India bringing together Indian entrepreneurs with entrepreneurs from Egypt, Malawi and the Philippines respectively made substantial progress in 1990. The 28 agreements signed (six in Egypt, nine in Malawi, 13 in the Philippines), amounted to a total investment of about \$5 million. As a result, the Government of India agreed to extend the project to cover Bangladesh and Indonesia. (J.2.2.03)

128. The export processing zone (EPZ) is often considered a viable instrument in attracting foreign investment, creating additional employment and promoting export-oriented industries. In response to an increased number of developing countries requesting advisory services on the establishment of EPZs, UNIDO consolidated its activities in that field by establishing a programme that can systematically and effectively respond to the needs of developing countries in improving their understanding and knowledge of the concept of an EPZ. Technical co-operation projects carried out in 1990 included advisory services and training in EPZ development, management and promotion and generally comprised the following stages of intervention: preliminary investigations on the viability of an EPZ within the context of the client country's economic and industrial development; feasibility studies on the EPZ including identification of potential investors and industry mix (market surveys), draft legislation, administrative and organizational structure, physical planning, financial and economic analysis, promotional measures; assistance in the establishment of an EPZ including advice in developing infrastructure, in management and operation, in promotional and marketing techniques, in research to target product opportunities, and in improving communications and co-operation among EPZs. In 1990, projects involving assistance in one or a combination of the above areas were carried out in Liberia, Malawi, Nepal, Nigeria, Panama and Togo. (J.2.2.03)

129. The UNIDO programme for the development of industrial sub-contracting between large contracting enterprises and small- and medium-scale industries continued to expand with the objective of promoting industrial development. A methodology and standard instruments were developed for the effective organization of sub-contracting and the establishment of sub-contracting exchanges or agencies in developing countries. This work covered sub-contracting nomenclatures and terminologies, computer software in support of match-making operations, operational manuals, guidelines on how to promote and set up sub-contracting exchanges, and guidelines and

46/ IOB.5/10, chap. II, para. 127; IOB.6/10, chap. II, para. 131.

model contracts for the establishment of sub-contracting and partnership agreements. Programmes for the establishment of regional sub-contracting systems and networks were implemented for Arab States (Algeria, Egypt, Iraq, Jordan, Morocco and Tunisia) 48/ and launched in Latin America (Argentina, Chile, Colombia, Ecuador, Mexico, Peru, Uruguay and Venezuela), the latter with the support of a financial contribution from Italy. 48/ Another project, funded by a Swiss contribution, was developed to design and implement the sub-contracting system and network among other Latin American countries, namely Bolivia, Brazil, Cuba, Guatemala and Paraguay. Similar activities were under preparation for other regions. At the national level, sub-contracting exchanges were established or developed in Algeria, Iraq, Morocco, Tunisia and Turkey. Work initiated in previous years by means of contributions from Belgium and France continued for the promotion of international sub-contracting and partnership between industrialized and developing countries. 48/ In that context, in addition to the agreement with the "Marché international de la sous-traitance" (MIDEST), at Nancy, France, 48/ co-operation was initiated with other international institutions such as the Business Co-operation Network of the European Community (BC-Net), at Brussels, Belgium, and the International Network of Subcontracting and Partnership Organizations (RIOST), at Bayonne, France. In a number of developing countries technical co-operation continued to be provided 49/ either in establishing national chambers of commerce and industry or in strengthening their functions and services, as in Morocco and Sierra Leone. Within the framework of the programme of product adaptation for export, large-scale assistance continued in the establishment of the Industrial Design Centre of Jamaica and advisory services to the five Indian Ocean islands. (J.2.2.04)

130. One of the innovative activities related to rural industry development was implemented in four regions of Guinea. Seed money as a revolving fund was a built-in component of a project to enable Guinean entrepreneurs engaged in small-scale industrial activities to have access to investment credit facilities without being hampered by traditional stringent mortgage requirements. 50/ Through this innovative method, some 29 small-scale industrial units were successfully implemented with a record repayment schedule observed by the entrepreneurs. Similar activities were designed for a number of countries at their request. In Madagascar, the introduction of poultry-keeping in rural areas for industrial scale production and export of delicacies such as liver and other by-products, was another innovative project

48/ IDB.6/10, chap. II, para. 135.

49/ *Ibid.*, para. 136.

50/ IDB.5/10, chap. II, para. 131.

for rural areas. It helped to create new job opportunities and develop rural industries, as well as to increase substantial foreign currency. (J.2.2.05)

131. The entrepreneurship development programme continued to expand, branching out into new areas based on the needs of recipient countries. 51/ Pilot training programmes specializing in entrepreneurship were carried out to provide advisory and consulting services to newly established businesses and to existing industrial enterprises. Two important areas of entrepreneurship development initiated in 1990 include business incubation centres as a highly efficient facility in support of newly set up manufacturing units; and the introduction of the "total quality concept" into small- and medium-scale industries as an important measure to improve the quality of products and reliability of firms. UNIDO convened a workshop on those two issues at Trieste in November, with participants from the European regional project for developing small entrepreneurial industries; similar workshops were planned in other countries to improve the quality of the products of developing countries and their competitiveness in the world markets. After elaboration in 1989 of a strategy and approach to the UNIDO privatization programme, the programme became operational in 1990. In a first workshop held in Vienna towards the end of 1989, government officials and policy makers from 20 countries were introduced to the UNIDO framework of privatization. As a follow-up, UNIDO assisted in preparing concepts, action plans and project documents. The programme was launched at an opportune moment when the economic restructuring of many countries in the developing world and in Eastern Europe was taking place. In Angola, for example, UNIDO provided high-level advice to the Government to develop the overall privatization strategy; this is to be followed by assistance in implementing a pilot programme for privatizing 10 of the country's State-owned enterprises. Assistance was also provided to the Government of Poland in developing its overall privatization strategy which would be implemented through trust fund arrangements. (J.2.2.06) (see also J.2.2.03)

## INDUSTRIAL MANAGEMENT AND REHABILITATION

132. Technical co-operation expenditures under the heading of industrial management and rehabilitation (J.2.3) amounted to \$7.9 million. Some 79 per cent of total implementation was financed from UNDP resources. A total of 98 projects were implemented or under implementation.

133. In the activities under industrial management and rehabilitation particular

51/ *Ibid.*, para. 132.

attention was given to the development of integrated approaches to technical co-operation. This involved strengthening management and local consultancy capabilities, introducing improved methodologies and carrying out diagnostic and restructuring operations. While rehabilitation activities were oriented at four levels - policy, sectors/subsectors, institutional infrastructure and enterprises - co-operation as regards management was aimed at improving returns on invested capital.

134. In the field of management, possibly as a consequence of government restructuring programmes, there were more requests to support private sector activities. This trend was correctly anticipated by a World Bank-financed project in Uganda, 52/ which resulted in recommendations as to which enterprises should be divested, liquidated or rehabilitated. The ensuing activities involved diagnostic management audits and considerable training of national personnel to implement the recommendations. Another such project took place in Mali 53/ where UNIDO, in close co-operation with the European Development Fund, provided technological and managerial inputs for the upgrading of existing industries. Activities continued to strengthen the management of State corporation in Guyana 54/ and industrial project implementation in Ethiopia. (J.2.3.01)

135. The rehabilitation programme continued to promote an integrated approach, addressing problems at the enterprise level within subsectoral, sectoral and macro-economic contexts and mobilizing the involvement of many organizational units of UNIDO. This approach led to joint project implementation between various branches of UNIDO, notably in feasibility studies as in Togo and Djibouti, and in industrial planning as in Zaire. Such projects stressed enterprise turnaround and modernization with assistance in strategic diagnostics, turnaround work plans and introduction of modern engineering techniques. The most significant example was a large-scale project in Indonesia, 55/ where a heavy engineering public corporation was assisted to upgrade its management and manufacturing systems through the application of value engineering, group technology, shop-floor control, total quality management and management information systems. In another project, the largest manufacturer of milling machines in China was given assistance in installing a computer-based manufacturing

resource planning system. Most rehabilitation projects have an important management component, including organizational software (methods systems and procedures) and human resource development, consistent with UNDP priorities as well as with the policy of self-reliance to optimize performance with given equipment and technology. The lack of planned maintenance has been universally recognized as a major cause of poor performance. Therefore, projects to install preventive maintenance systems were implemented in Burkina Faso, Burundi, Indonesia and Philippines. Similarly, energy management aspects were recognized as a key to rehabilitation. Accordingly, a European regional energy conservation network continued to be developed in an effort to establish a sound basis for commercial co-operation between the participating countries and strengthening the network capabilities in the field of environmental protection. 56/ In that context, a Euro-Arab Workshop on Energy Conservation in Industry aimed at transferring to the Arab region the experience gained in the European network. A mission to Sao Tome and Principe to complete the diagnostic phase of a restructuring programme financed by the World Bank, 53/ resulted in a project to assist the country in financial and cost accounting. Prominent examples of modernizing plant operations were projects in Somalia and Malawi. (J.2.3.02(i))

136. Increased involvement of local industrial consultancy services in national development activities is considered desirable by developing countries. Thus assistance to enhance the capabilities of national consultant firms was provided to Antigua, Nigeria and Somalia. 52/ Similarly, the application of computers to improve operating unit efficiency and to introduce advanced management and operations research methodologies was featured in the Republic of Korea. Also, a large-scale project in the Philippines further strengthened the national management and consultancy services through the introduction of technical and financial instruments for implementation of energy conservation measures. (J.2.3.03)

137. With the exception of the extended wooden bridge project in Panama, and a large-scale project for the development of the wood industry in Cameroon, activities in the wood sector were confined, as expected, to smaller projects. 57/ Examples of projects in human resource development were again evident with a technical course held in Malaysia for the Asia and Pacific region, and in-service training provided in Democratic Yemen in the modernization of the technical and managerial capacities of two carpentry co-operatives. Assistance was provided to

52/ IOB.6/10, chap. II, para. 143.

53/ *Ibid.*, para. 142.

54/ *Ibid.*, para. 140.

55/ *Ibid.*, para. 139.

56/ *Ibid.*, para. 141.

57/ *Ibid.*, para. 144.

the Government of Guyana in arranging for the private sector to manage the existing Forest Industries Development Unit as a service and training centre. In Panama a project was launched to demonstrate the effective use of pinewood for furniture and building in rural areas. (J.2.3.04)

138. Besides direct technical co-operation activities, considerable effort was dedicated to preparation of training material and technical guides on particular issues such as the application of personal computers or micro-computers in industry in developing countries and on techniques of enterprise diagnostics. In this respect, a methodological guide for consultants on diagnostics was published during the year for use by international and local personnel in developing countries, while manuals for selected groups of enterprises in priority subsectors of industry were under preparation (J.2.3.02(ii)).

### FEASIBILITY STUDIES

139. Technical co-operation expenditures under the heading of feasibility studies (J.3.1) amounted to \$5.9 million. Some 63 per cent of the total implementation was financed from UNDP resources. A total of 120 projects were implemented or under implementation.

140. The year witnessed a widening of the scope of activities related to feasibility and pre-feasibility studies that was reflected, *inter alia*, in increased co-operation with private enterprises, in assistance provided for enterprise rehabilitation, in co-operation with industrial development financing institutions, and in the promotion of projects in the industrial services sector, including investment advisory activities.

141. These innovative activities led to several requests from export credit insurers to appraise the viability of investment projects in various developing countries; insurers in industrialized countries are prepared to mobilize funds for industries in developing countries, provided the risk assessment is reliable. Appraisal work resulted in positive recommendations for investments, for example, in the case of shoe components in China, meat processing in Argentina, casual clothing in Burkina Faso and industrial fisheries in Cameroon. (J.3.1.01(i))

142. The good reputation of the pre-investment work rendered by the Organization led to the follow-up of an earlier pre-feasibility study carried out by UNIDO for the Government of Madagascar. During 1990 the Malagasy Government, the French Government and the European Community contributed a total amount of \$1 million to finance pre-investment work under the first phase of a fishery project that will require an estimated investment of \$35 million. An example of co-operation with the private

sector is the large special-purpose contribution from potential Japanese investors that enabled several pre-investment studies to be carried out. (J.3.1.01(i))

143. A large number of projects were completed during the year in the area of traditional work on feasibility studies. These studies play a leading role in the area of industrial rehabilitation at the enterprise level, particularly in the economic, financial and marketing aspects. In that respect the Organization's integrated and comprehensive methodology was further developed and implemented in both north and sub-Saharan Africa. A successful support study on assistance to enterprises was carried out for Mali through feasibility studies on rehabilitation and privatization that covered economic, financial, managerial, commercial and technical aspects, for a local joint venture (J.3.1.01(i)). Pre-diagnostic studies of selected groups of enterprises and a round-table meeting with development finance institutions in Africa, which were to be carried out within the framework of IDDA, had to be postponed for lack of funds. (J.3.1.01(ii),(iii))

144. Parallel to co-operation with private investors is the UNIDO mutually reinforcing programme of co-operation with development banks that enables these banks to increase their appraisal capacity. UNIDO co-operation with industrial banks took place for example in Algeria, Ghana, Nigeria, Sri Lanka and Zambia. The Organization also initiated the mobilization of advice on the development of the Community Bank for Women in Ghana. Activities continued in the area of national and subregional institution building projects. One example is a project in Saudi Arabia on industrial advisory services to the Ministry of Industry and Electricity, which was extended into a new phase at the beginning of July. Other activities aimed at upgrading the national capabilities to conduct pre-investment studies are described in paragraph 146 below. (J.3.1.02)

145. Further developments took place with respect to the mainstays of methodological work. In addition to the extension of the UNIDO Computer Model for Feasibility Analysis and Reporting (COMFAR) by a COMFAR Data Bridge module that allows the exchange of data between COMFAR and the software package LOTUS 1-2-3, 58/ adaptations were made to permit COMFAR to run on local area networks (LAN). The revised edition of the Manual for the Preparation of Industrial Feasibility Studies (ID/206) was finalized 58/ and is scheduled for publication in 1991, while the draft of a manual for the preparation and evaluation of small business investment projects was completed. (J.3.1.03)

58/ *Ibid.*, para. 169.



146. Emphasis was placed on upgrading the skills required for the preparation and evaluation of pre-investment studies. For that purpose 33 seminars were conducted in countries in Africa, Asia, Europe and Latin America. At these seminars, a total of 825 participants from development banks, private firms, institutions and promotional bodies were trained in the application of the UNIDO methodology on project identification, preparation, evaluation and financing. The success of the seminars is evidenced by the frequent requests from developing countries for more specialized training programmes of short duration in, for example, market analysis for investment projects and cost-benefit analysis. UNIDO's methodological work on project evaluation also included a seminar conducted by the Government of China, UNDP and UNIDO on various methodologies for the economic evaluation of projects. The growing number of self-financed seminars for users of COMFAR held at UNIDO Headquarters, including one held specially for Nigerian investment bankers, is an example of how the widening scope of UNIDO's pre-investment work also promoted the methodological work. (J.3.1.04)

#### INDUSTRIAL HUMAN RESOURCE DEVELOPMENT

147. Expenditures for fellowships and other training components in all technical co-operation projects implemented by UNIDO amounted to \$23.2 million. Of that total \$16.1 million was spent on fellowships and study tours and \$7.1 million on group training activities and meetings. Technical co-operation expenditure under the heading of training that received substantive backstopping from the Industrial Human Resource Development Branch (J.3.2) amounted to \$6.1 million. Some 16 per cent of this implementation was financed from UNDP resources. A total of 141 projects were implemented or under implementation.

148. Industrial training infrastructure was given high priority as illustrated by the following activities. To strengthen institutions responsible for training trainers in design and pattern-making techniques in the shoe industry, a kit of instruction material and training aids was developed by a multidisciplinary team of specialists. The kit will help trainers to organize and conduct training programmes in these techniques. The project foresees three such training programmes for English-, French- and Spanish-speaking countries. The first programme was held at PISIE (Politecnico Internazionale per lo Sviluppo Industriale ed Economico) in Italy, for 18 participants from English-speaking countries. Upon completion of the training programme, the kit of instruction material and required equipment will be given to the participants' institutes. (J.3.2.01)

149. Under SIS financing, as a follow-up to the First Consultation on the Electronics

Industry (1989), assistance to identify alternative strategies for technical training in the electronics industry was provided to Malta in 1990. The findings of that project were subsequently discussed with high-ranking Government officials at UNIDO Headquarters. With a view to strengthening existing training institutions in Africa, a survey was undertaken of training capacities and capabilities of selected management training institutions in Eastern African countries. Within the framework of the programme for IDDA, advisory services were provided for designing and establishing an information system for training needs and opportunities in Madagascar; the objective of the system is to collect human resource data within the industrial subsectors which will enable the Government to review and develop the basic education system and make it more responsive to changing industrial manpower needs. Also in Africa, a large-scale project with UNDP financing and Government cost-sharing was launched in the Libyan Arab Jamahiriya to establish an integrated education and training system at an industrial institute. (J.3.2.01)

150. Entrepreneurship development continues to gather momentum in an atmosphere dominated largely by market-driven economies in developed as well as developing countries, where small- and medium-scale enterprises are the primary factors to increase job opportunities and improve income distribution. To meet the demands for increasing numbers of competent entrepreneurs, a project on modular approaches to managerial and entrepreneurial skill development was developed for a group of Asian countries. The ultimate objective of the project is to increase the supply of capable entrepreneurs from all strata of society in those countries through management and entrepreneurship training and motivation to set up new small- and medium-scale industrial enterprises in the private sector. To achieve this objective, the project aims at strengthening the capacity and capability of selected entrepreneurship development training institutions, through training of trainers by means of modular approaches. The project consists of four phases; phase one lasted three weeks at Maastricht, the Netherlands, with 14 participants from five countries: Bangladesh, India, Malaysia, Pakistan and Thailand. (J.3.2.01)

151. In support of industrial training through fellowships, the nineteenth edition of the UNIDO Guide to Training Opportunities for Industrial Development (PI/105) was published, as was the 1990 issue of the UNIDO Industrial Training Offer Programme (PI/106). A detailed breakdown of fellowships and study tours is given in appendix I, tables 3 and 4, including the number of female participants and participants from least developed countries. (J.3.2.02)

152. In the area of industrial group training a number of activities were

undertaken, as described in the following paragraphs. A detailed breakdown of in-plant and other group training programmes is given in appendix I, tables 1 and 2. Efforts to utilize in those programmes training capabilities from developing countries continued, for example, in the field of railways. 59/ Within the framework of North-South and South-South co-operation, a programme for African decision makers and managers responsible for the rehabilitation of rolling stock was organized for the second time: the first part of the programme was held in the United Kingdom while the second part took place in Malawi. This process was based on a decision reached with the Union of African Railways to hold training programmes in various African countries on a rotative basis. A similar programme was held in the United Kingdom and Egypt for engineers on repair and maintenance of railway track. Based on the experience gained in Africa, the launching of identical programmes in Asia is under consideration in collaboration with the Transport, Communications and Tourism Division of the Economic and Social Commission for Asia and the Pacific next year. (J.3.2.03)

153. A training programme in the production of construction material was held in Morocco for 55 participants from Algeria, Morocco and Tunisia. The programme also involved the UNIDO System of Consultations in anticipation of the second Consultation on the Building Materials Industry scheduled to take place at Athens, Greece, in March 1991. The participants submitted a plan of action aimed at stimulating the building materials sector in the following areas: quality control and product certification; energy-saving in the manufacture of materials; acquisition of raw materials; maintenance and maintenance training; and the establishment of technical centres in the countries of the Maghreb. The success of the programme led to the setting up of a follow-up committee to look into the possibilities of institutionalizing it. (J.3.2.03)

154. The lack of spare parts is a major cause for the low rate of productivity in many Latin American countries and has therefore been accorded high priority in the region. UNIDO thus organized a training programme for those countries on the manufacture of tools and spare parts. Representatives from ministries and industrial training institutions attended the programme. (J.3.2.03)

155. A training course on computer services and software in industry was held in Paris for countries of the Asia and Pacific region. The course was aimed at increasing awareness in CAD/CAM, and computer-assisted production management (CAPM). (J.3.2.03)

156. Within the framework of group training programmes, an example of the practical

application of planning strategies and methodologies for human resource development is the assistance provided to the Erdimir Iron and Steel Works in Turkey in the improvement of their training facilities through the introduction of advanced training methods and techniques e.g. appropriate hardware and software for a computer-based training system. This complements the inputs of the Turkish authorities for establishing a training centre in the Erdimir steel works, a follow-up to earlier UNIDO assistance. The Erdimir steel works is one of the two main host institutions implementing national and interregional modular training activities in the iron and steel industry on behalf of UNIDO since 1983. (J.3.2.03)

157. Within the framework of activities concerning planning strategies and methodologies for human resource development in industry, a meeting was held in Paris in June in co-ordination with the World Bank, the Development Centre of the Organisation for Economic Co-operation and Development, and the International Centre for Advanced Technical and Vocational Training of the International Labour Organisation at Turin, Italy. Topics considered at the meeting were: formal instruction at training institutions or centres, including educational institutions complementing in-service and in-house training; training through on-the-job guidance; continuing training concepts for employees or entrepreneurs; introductory in-house training for newly recruited personnel (essentially job-specific training); and apprenticeship training in enterprises of a specific industrial sector. At the meeting, a plan of action was drawn up for the implementation of an industrial human resource development programme for sub-Saharan African countries. (J.3.2.04)

158. During 1990, developments in the Central and Eastern European countries and the need to modernize the existing industries and establish new ones based on high technologies in some developing countries exerted greater demands on the UNIDO human resource development programme. The constraints faced in this respect were drawn to the attention of the Board at its seventh session (IOB.7/21, para. 36).

## INTEGRATED INDUSTRIAL PROJECTS

159. Until the third quarter of 1990, activities under the heading of integrated industrial projects (J.5.2) continued to include the co-ordination, monitoring and, in selected cases, the implementation of large-scale, multidisciplinary technical co-operation projects, as well as the organization of workshops, preparation of reports and the co-ordination and implementation of a number of technical co-operation projects in the areas of energy, computer systems and environment. In connection with the establishment of the new Environment Co-ordination Unit, part of

59/ *Ibid.*, para. 159.

the staff of the Section for Integrated Industrial Projects was redeployed and responsibility for the implementation of technical co-operation projects, in selected cases, was transferred to other Branches of the Department of Industrial Operations. Activities concerning environment (J.5.2.02) are reported under a separate heading (cf. chap. IV), while examples of technical co-operation projects carried out until the end of September are given below.

160. Large-scale multidisciplinary projects continued to be implemented in Egypt and in Jordan. The purpose of the Egyptian project is to improve production capacities and the maintenance and management of public and private sector enterprises through the provision of advisory services in industrial sectors such as leather, energy, machinery and the food industry. 60/ The project in Jordan is aimed at upgrading the capability of the Ministry of Industry and Trade by setting up a planning and co-operation unit and a computerized integrated industrial data and information system to support planning activities. 60/ The capability of the Food Quality Control Laboratory of the Ministry was strengthened through a seminar on quality control and by providing laboratory equipment. Short-term consultancy services were provided in the cement, ceramics, and metal casting sub-sectors. 60/ Another large-scale, multidisciplinary project initiated in the Libyan Arab Jamahiriya provides technical assistance to the industrial subsectors falling under the responsibility of the Secretariat for Strategic Industries and makes specific recommendations on the introduction and/or adaptation of industries in fields such as electronics and photovoltaics. In the Syrian Arab Republic, an ongoing multidisciplinary project is aimed at improving industrial performance at the sectoral level. 60/

161. Implementation continued of a preparatory assistance project, begun in 1989 in Indonesia, to carry out a diagnostic study of existing maintenance systems, diagnostic facilities and the overall organizational structure and manpower skills. 61/ On the basis of those diagnostic studies, a draft project document will be prepared containing alternative strategies for the introduction

of preventive maintenance and the establishment of an institution to deal with those aspects of industry. In connection with the promotion of the joint FAO/UNIDO programme, concepts were developed to examine the viability of projects to use industrial waste for agricultural purposes, e.g. in the case of Bahrain. (J.5.2.01)

162. A number of proposals for technical co-operation projects on energy were formulated on the basis of government requirements. One of those proposals, based on the request of a group of African countries, is aimed at strengthening energy conservation on a regional basis, including the design and implementation of pilot energy conservation systems, the establishment of a regional information network on industrial energy conservation, and the development of manpower resources. 62/ (J.5.2.03)

163. As regards computer systems, consultancy services were provided to the Libyan Arab Jamahiriya within a project aimed at introducing an office automation system in the Secretariat for Strategic Industries and CAD/CAM technologies for industrial application, particularly in engineering industries. A project was prepared for provision of expertise to the Syrian Arab Republic on management information systems and office automation as well as industrial mechanization and automation. Regional projects to appraise the possibility of establishing industrial data banks were also prepared for the Arab Railways Union and for the Arab Union for Cement and Building Materials. Work started on a publication that is aimed at improving the efficiency of small and medium-sized industrial enterprises through computerization. (J.5.2.04)

164. During the Interregional Symposium on the Role of the Industrial Co-operative Movement in Economic and Industrial Development held in Moscow in June, 63/ UNIDO was requested, among others, to continue further diagnostic studies of problems related to the development of the industrial co-operative movement and to provide a wide-ranging exchange of information on industrial co-operatives and small-scale enterprises in different countries, also through the organization of similar symposia on a regular basis.

60/ IDB.6/10, chap. II, para. 174.

61/ Ibid., para. 176.

62/ Ibid., para. 177.

63/ Ibid., para. 175.

## CHAPTER III. INDUSTRIAL PROMOTION

### SYSTEM OF CONSULTATIONS

1. The consultation process has continued to stress inter-sectoral and inter-divisional linkages in both preparatory and follow-up activities. In order to integrate the consultation process with all UNIDO activities and in accordance with the actions recommended by the Director-General in response to the evaluation of the System of Consultations submitted to the General Conference at its third session (GC.3/20), in-house advisory committees were established covering building materials, fisheries, machine tools, petrochemicals, wood and wood products and industrial rehabilitation/restructuring. The advisory committees are responsible for initiating and monitoring preparations for and follow-up to Consultations. Activities of the Consultations are conducted in close co-operation and co-ordination with other organizational units in the Secretariat. In addition, joint activities or close co-operation are carried out with other United Nations specialized agencies and organizations such as the International Labour Organisation (ILO), Food and Agriculture Organization of the United Nations (FAO), World Health Organization (WHO), United Nations Conference on Trade and Development (UNCTAD), International Trade Centre UNCTAD/ GATT (ITC), United Nations Educational, Scientific and Cultural Organization (UNESCO), United Nations Children's Fund, as well as with the United Nations regional commissions, intergovernmental and non-governmental organizations.

#### Consultations convened in 1990

2. The Regional Consultation on Industrial Rehabilitation/Restructuring with Special Focus on the Food-processing Subsector in Africa (G.2.4.03), was convened in Vienna from 12 to 16 November. <sup>1/</sup> The Consultation, which was attended by 94 participants from 48 countries and five organizations as well as industrial and commercial enterprises, recommended establishing policies which combine the process of rehabilitation of enterprises with the industrial restructuring programmes in order to ensure dynamic growth, domestic economic integration and the provision of support industries and services.

3. The second Consultation on the wood and wood products industry and the second Consultation on the building materials

industry, both originally scheduled for 1990, were postponed to 1991 (see paras. 14 and 15 below). A number of other activities planned for 1990 also had to be postponed owing to lack of funds.

#### Follow-up to earlier Consultations

4. The consultation process has fostered the identification of technical co-operation projects both during and after the Consultations, and particularly during sectoral workshops and expert group meetings. As follow-up to the four 1989 Consultations, a plan of action (IDB.6/12, annex) was drafted for technical co-operation and investment projects in the fields of small- and medium-scale industry development, the electronics industry, fruit and vegetable processing and rural transport equipment. UNIDO Country Directors were involved in the follow-up and assisted in identifying sources of funds and selecting suitably qualified candidates to attend meetings.

5. In support of the sugar-cane industry in Africa, and as follow-up to the First Interregional Consultation (1988) on the Food-processing Industry with emphasis on Sugar-cane Processing, an Expert Group Meeting for the African region in promoting Regional Co-operation for the Establishment of an organizational framework for Sugar-cane Producers and Co-operation on Technology and Market, was held in Vienna from 5 to 8 June. The expert group considered two studies on the potential and benefits of an inter-governmental organization of African sugar-producing countries, recommended its setting up and agreed on its draft statutes (G.2.1.03).

6. As part of the follow-up to the First (1987) Consultation on the Fisheries Industry, a workshop on the Fisheries Industry in the Caribbean Islands was held in Trinidad and Tobago in September, which made some practical recommendations for the development of the fisheries industry in the region, e.g. that a survey be undertaken on infrastructure facilities for fish-processing (G.2.1.04). (See also para. 17 below.)

7. As follow-up to the First Consultation (1987) on the Non-ferrous Metals Industry, and because of the importance of the aluminium industry in Latin America and the potential for production complementarities resulting from the abundance of natural resources and the expertise available in the region, a Regional Expert Group Meeting on Production Complementarities in the Aluminium Industry in Latin America was convened at Kingston, Jamaica, from 23 to 26 July. At the meeting, which was held in

<sup>1/</sup> For the report on the Consultation, see document ID/WG.499/4.

co-operation with the Jamaica Bauxite Institute and attended by 23 participants and two observers, two studies were examined on production complementarities of the main producers of aluminium for the South American (Argentina, Brazil and Venezuela) and Caribbean regions. Four projects were formulated and will be undertaken by UNIDO once funds are identified: (a) a study on environmental issues (i.e. trends, patterns) and their effect on industry in the near future; (b) an ongoing review of the technical standards and norms in the industry to keep abreast of world requirements in this area; (c) a feasibility study to establish additional caustic soda capacity in the region; and (d) a study on the identification of semi-fabricated and fabricated products to be manufactured in the region. As a main outcome, the meeting recommended that UNIDO organize a permanent panel of experts for the region to further discuss ways to promote an integrated development of the aluminium industry among the producer countries in the region (G.2.2.05). Such an activity, when undertaken by UNIDO, would be an important example of innovative economic co-operation among developing countries.

8. Following the First Consultation (1989) on the Electronics Industry, UNIDO participated in the Latin American Economic System (SELA) meeting on Industrial Co-operation in the Electronics Industry held at Sao Paulo, Brazil, on 12 and 13 June. The participants recommended that a meeting of specialists in the electronics industry be held in Latin America to review policies and a programme for further development of the sector. It will be held in 1991, if funds are available. The establishment of regional centres for training and information in electronics was also considered (G.2.2.06).

9. As follow-up to the Regional Consultation (1988) on the Phosphatic Fertilizers and Pesticides Industries in Africa, an Expert Group Meeting on the Processing and Utilization of Phosphates was convened at Dakar, Senegal, from 3 to 6 January. 2/ The experts concluded that, since few African countries have a population big enough to consume the fertilizers produced by world level plants, they should evaluate the current technical potential of mini-plants for the production of sulphuric acid, ammonia, superphosphate and partly acidified phosphate. The experts also advised that, before launching world level projects, a feasibility study should be conducted to establish whether products could be obtained competitively with similar world trade products and that if such conditions existed, regional and subregional co-operation should be promoted to further develop this sector. In the pesticides sector, a study was conducted on the

production possibilities of botanical pesticides in developing countries with specific reference to Africa. The economic and technical options for industrial production were reviewed and assessed, and the study concluded that in many instances botanical pesticides offered a practical alternative for the development of the pesticides sector in Africa. The International Fertilizers Development Center and FAO actively co-operated in that meeting (G.2.3.01).

10. As follow-up to the Third Consultation (1985) on the Petrochemical Industry, a Workshop on Co-operation among Developing Countries on Plastics in Agriculture in Arid and Semi-arid Zones was held at Algiers, Algeria, from 12 to 16 February. It concluded that, in addition to the increase in agricultural production, particularly out-of-season products, the greatest advantage of plastic material in countries of the arid and semi-arid zones was its use in water management - water collection, preservation and transportation - and in irrigation (G.2.3.02). Three ministries and 13 national organizations from Algeria co-operated in organizing this meeting.

11. Following the Third Consultation (1987) on the Pharmaceutical Industry, an Interregional Meeting on Co-operation among Developing Countries for the Development of the Pharmaceutical Industry was held at New Delhi, India, from 19 to 22 March. It recommended that UNIDO further study the potential to develop the use of medicinal plants in industry in developing countries, with specific reference to the development of locally available skills, process technology, the establishment of pilot plants, support to R and D institutions and regulatory and financial aspects (G.2.3.03).

12. Recommendations on the key issue of training of personnel for maintenance of industrial plants were made not only at the Second (1987) Consultation on Training of Industrial Manpower, but also at Consultations concerning other sectors. Accordingly, a plan of action on human resource development in industrial maintenance was prepared for discussion at an expert meeting planned for 1991. A joint ILO/UNIDO study on maintenance management was also prepared (G.2.4.01).

13. As recommended by the First Consultation (1989) on Small- and Medium-Scale Enterprises including Co-operatives, preparations were under way for a directory on the development of small- and medium-scale enterprise support organizations (G.2.4.02).

#### Programme of Consultations for 1991

14. At the Global Preparatory Meeting for the Second Consultation on the Wood and Wood Products Industry held at Nairobi, Kenya, from 24 to 27 April, agreement was

2/ IOB.6/10, chap. III, para. 8.

reached on the key issues to be examined by the Consultation to be held in Vienna, from 21 to 25 January 1991. These issues include: (a) measures to strengthen an environmentally sound and sustainable supply of timber resources for the secondary wood-processing industry, as well as the utilization of currently commercially less-accepted species and plantation species; (b) utilization of wood as a source of locally-available low-cost building material in housing and construction; (c) prerequisites for the integrated development of the secondary wood-processing industry, including the need for technical and technological co-operation at the international and regional levels. Preparation of the Consultation included the active involvement of FAO and the United Nations Centre for Human Settlement (Habitat) (G.2.1.02).

15. Three studies were prepared for the substantive servicing of the second Consultation on the building materials industry to be held jointly with Habitat, in 1991 (G.2.2.04). Based on the preparatory work and the conclusions and recommendations of regional and inter-regional group meetings previously, the following two issues were proposed for discussion at the Consultation: (a) strategies and policies for the development of the building materials industry in the developing countries; and (b) measures to strengthen the low-cost building materials industry in developing countries.

16. Preparatory work was undertaken for the fourth Consultation on capital goods with emphasis on machine tools to be held in Prague, Czechoslovakia, in 1991 (G.2.2.03). The issues for the Consultation will be defined at the regional expert group meeting for Latin America on the capital goods industry with emphasis on machine tools, to be held in Santiago de Chile from 8 to 11 April 1991.

17. Two studies were prepared on the fisheries industry in the Pacific Islands and the Asian region for a global meeting on fisheries, which is to be held in the latter half of 1991 in preparation for the regional Consultation on the fisheries industry in Asia and the Pacific (G.2.1.04).

18. Five industrial profiles for petrochemical products to be produced in the Arab countries were prepared in co-operation with the Arab Industrial Development and Mining Organization and submitted to the Second Arab Conference on the Integration of the Petrochemical Industry in the Arab Countries convened at Tunis, Tunisia, in May. A study on trends in technological development in the petrochemical industry was prepared as a background paper for the global preparatory meeting and the regional Consultation on the petrochemical industry in the Arab

countries, both planned for 1991, but postponed 3/ (G.2.3.02).

## DEVELOPMENT AND TRANSFER OF TECHNOLOGY

19. Progress continued in the major promotional programmes for the development and transfer of technology, although financial constraints prevented a number of the regular budget activities from being carried out as scheduled.

20. In the field of technology monitoring a regional Latin American programme was being promoted during 1990. In addition to the Technology Monitors published on micro-electronics, genetic engineering and biotechnology, and new materials, a new Monitor on marine industrial technology was under preparation. Financial resource constraints related to printing funds and consultancy hampered the production and publication of certain studies and Monitors. Thus it was not possible to complete all four issues of the Marine Industrial Monitor and there were no issues in the Development and Transfer of Technology series (G.4.1.01(i)). Concerning the management of technological change, several case-studies at the enterprise level in India were compiled, following a workshop held at New Delhi; other case studies were also being prepared on the management of change in computer-aided production technology in developed country enterprises (G.4.1.01(ii)). Studies related to global technology trends were prepared on the following: the changing technological scene in selected developing countries; technology flows to developing countries; state-of-the-art on technology forecasting; technological trends in non-chlorofluorocarbon technologies; and biotechnology policies and programmes in eight developing countries (G.4.1.01(iii)); (G.4.3.01(i)). Within the framework of the Task Force on Science and Technology of the Administrative Committee on Co-ordination, contributions were made to system-wide reports on endogenous capacity building (G.4.4.02(i)).

21. The project to implement a Regional Network for Microelectronics for Latin America and the Caribbean 4/ continued unabated, with progress in all thematic areas including strategies, acquisition of hardware and software, legislation on informatics, and production and commercialization of software. While this activity will extend into 1991, the preparation for a full-scale project on microelectronics for the fifth UNUP

3/ *Ibid.*, para. 15.

4/ IDB.5/10, chap. III, para. 17; IDB.6/10, chap. III, para. 18.

programming cycle (1992-1996) was initiated. Also in the field of informatics, assistance was provided to Trinidad and Tobago in the development of the software industry (G.4.2.01(iii)). The First Arab Investment Forum for Electronics (cf. para. 41 below) held in May was organized by UNIDO in co-operation with the Economic and Social Commission for Western Asia (ESCWA). At New Delhi, India, a workshop was held for participants from African and Arab countries as a follow up to the 1989 Conference on National and International Co-operation for the Telecommunications Industry in Africa. 5/ The participants had an opportunity to visit the "Electronics India '90" trade fair and to meet with Indian entrepreneurs. As a result, 20 memoranda of understanding for transfer of technology were signed. In addition, a project was formulated for the first phase of a feasibility study on the development of a regional Africa strategy for the manufacture of telecommunications equipment. The International Telecommunication Union was invited to comment on the project, which is being considered for financing under the Industrial Development Fund (G.4.2.01(v)). A study on informatics services was completed (G.4.2.01(i)). The investors' conference on telecommunications industry in Asia and the Pacific had to be postponed to 1991 (G.4.2.01(vi)).

22. The promotion of the International Centre for Genetic Engineering and Biotechnology (ICGEB) entered a new phase with the adoption of a five-year programme, for which funding to a value of \$55 million has been assured by the Governments of Italy and India as well as by the Research Area of Trieste. The principle of annually extending the five-year programme by another year was also adopted. Consequently, in June, the Preparatory Committee on the Establishment of the Centre endorsed the rolling of the programme to 30 June 1995. A total of 43 countries have signed the Statutes of the Centre, while 22 have ratified them. As the requisite number of ratifications for the Centre to become an autonomous entity is 24, the Preparatory Committee has begun to consider issues relating to the entry into force of the Statutes. Interest in ICGEB has increased among funding agencies. The Rockefeller Foundation awarded two grants to fund research and training programmes in the New Delhi component of the Centre. An Indian company has entered into an agreement with UNIDO, as executing agency of ICGEB projects, for making research grants available to ICGEB in return for exclusive licenses on the results of research undertaken on specific items. Applications with other possible sources of finance, including WHO, are pending. The United Nations Environment Programme (UNEP) offered to co-sponsor some training

programmes with ICGEB. To encourage contributions, a multi-donor trust fund for ICGEB research proposals and related specialized training was established by the Director-General. 6/ In 1990, within the ICGEB programme five short-term training courses were conducted for 115 participants from 25 countries, four major research colloquia were held and a number of long-term trainees began work at the Centre. A total of 44 collaborative research programmes from 12 affiliated centres were agreed. To date, some 50 scientific papers have been published by the ICGEB scientists. The first issue of the ICGEB newsletter, Double Helix, was published (G.4.3.01(iv)).

23. Issues related to biotechnology safety continued to be addressed, in particular through the informal UNIDO/WHO/UNEP/FAO working group (G.4.3.01(iii)). A project was approved for the development of a code of conduct on biotechnology safety and the establishment of an advisory group for assistance to developing countries in the safe practice of biotechnology and the use of biotechnological products. Two projects were being implemented, one for assisting Trinidad and Tobago in the microbial enhancement of oil recovery and the other for developing a protein beverage in the Republic of Korea. A workshop on biotechnology policies in Latin America, co-sponsored with SELA, was held at Lima, Peru, in October. Preparatory work was undertaken for an expert group meeting on the application of biotechnology to food processing in Africa (G.4.3.01(v)). A mission to Kenya was undertaken regarding the development of a programme on the use of biotechnology in the industrial production of natural products. A project on small-scale gari-processing technology, funded under the programme for the Industrial Decade for Africa (IDDA), was implemented.

24. Preparatory work for the establishment of an international centre for science and high technology at Trieste, Italy, included the following pilot activities: (a) in the field of pure and applied chemistry, an advanced computer graphics system and a reactivity laboratory were established, and a conference was held on lasers in chemistry; (b) in the case of earth and environment sciences, new research groups were set up and a mini-symposium conducted on climate and global change; and (c) in the field of high technology and new materials, a research group on semi-conductors and a photonics laboratory were created. In addition, several workshops were carried out in co-operation with the International Centre for Theoretical Physics at Trieste. Funding for 1991 for the future centre had already been assured and discussions were under way with the Italian Government to define an institutional structure and a long-term programme, so that a

5/ IOB.6/10, chap. III, para. 19.

6/ IOB.7/21, para. 19.

mechanism to ensure regular funding can be established. Professor Augusto Forti was appointed as the new project leader for the Centre as of 5 November 1990 (G.4.4).

25. In the area of new materials, a number of studies on their potential applications in developing countries has been undertaken, although one study on the status of techniques of materials engineering had to be postponed (G.4.4.01(i)). The preparatory phase for a project to promote the establishment of an international materials assessment and applications centre was drawn up and its financing was under consideration (G.4.4.01(iii)). A project to promote a regional network of material technology centres in Asia was being implemented. UNIDO also co-sponsored a workshop on new materials organized by the Commonwealth Secretariat at New Delhi in February. A report was prepared on the phenomenological exploration of the processes of research, development and market diffusion of new materials, financed by the Commission of the European Communities under a trust fund agreement with UNIDO.

26. In the area of new and renewable sources of energy, as a result of the 1989 meeting of the Consultative Group on Solar Energy Research and Application, 7/ activities focused on studies of the current and future market for photovoltaics and the large-scale manufacture of solar photovoltaics to reduce the unit costs. A methodological study on market developments in solar photovoltaics in developing countries was undertaken as a forerunner to a comprehensive study on the subject (G.4.4.01(viii)).

27. As part of the programme on marine industrial technology, an expert mission visited Egypt and Malta to review their respective offers to host the proposed Mediterranean regional centre for research and development in that field (G.4.4.01(vi)). Preliminary work has also been undertaken on a proposal to establish a similar regional centre on marine industrial technology in the Caribbean. A meeting in the Caribbean to discuss this subject was postponed to 1991 (G.4.4.01(v)). A viability study was completed and will form the basis of further discussions with Caribbean countries. At the request of India, a report was prepared on seabed mining, its technological challenges and economic prospects (G.4.4.01(iv)).

28. Within the programme on advances in manufacturing technology, a trust fund project is being implemented on the identification of opportunities to strengthen manufacturing systems in selected industries in Hungary and Poland. Publications in this programme area were postponed due to financial constraints (G.4.4.01(vii)).

29. The activities of the Industrial and Technological Information Bank (INTIB) (G.3.1.01) were reoriented to take account of General Conference resolution GC.3/Res.7 and the recommendations of the third meeting of the INTIB Advisory Group held in Vienna in March 1989. The INTIB network of over 70 national and four regional focal points is designed to facilitate the exchange of industrial inquiries, to help develop and promote information sources and users, and to provide direct access to computerized sources of industrial and technological information. The network was expanded through regional sub-networks in Africa, East Europe and Latin America and the Caribbean. Meetings were held at Dakar, Senegal, for the African network, at Melnik, Czechoslovakia, for the East European network, and at Havana, Cuba for the Latin America and Caribbean network (G.3.1.01(i),(iii)). The activities of the INTIB network were further strengthened through: modernization of the information data bases; addition of a new data base on forestry; technical co-operation projects in selected African countries, including training in the use of INTIB and other UNIDO information systems; and training in personal computer on-line access to technology-related data bases in Moscow, Union of Soviet Socialist Republics, and in the use of modern optical storage technologies at Warsaw, Poland. A training programme was also developed in the maintenance of hardware and software, use of personal computers (PC), electronic communications, information resource management, and optical storage technologies (G.3.1.02(i),(ii),(iii)).

30. The Industrial Inquiry Service supplied assessed information in response to 1,500 inquiries. INTIB activities, services and products and UNIDO publications were promoted through demonstrations and exhibits at the "Universities-Industry" technology transfer conference and the "World Tech Vienna" fair in Austria, at the technology exchange business forum "TECH-EX '90" in Bulgaria, and at the "mobile" workshop on information systems with special emphasis on South-South co-operation held in Yugoslavia in April. In co-operation with the International Atomic Energy Agency, FAO and UNESCO, an International Symposium on the Future of Scientific, Technological and Industrial Information Services was held with participants from many developing and industrialized countries at Leningrad, Union of Soviet Socialist Republics, from 28 to 31 May. With funding from a special-purpose contribution to the Industrial Development Fund (IDF) by the Government of Sweden, an environment information programme was prepared as a support tool for the UNIDO environment programme. As a medium for the programme, distribution began of a monthly Environmental Awareness Bulletin. A first commercial product - a PC version of METADEX - was launched through a licence agreement concluded with the American Society of Metals International and the

7/ IDB.6/10, chap. III, para. 25.



Institute of Metals, United Kingdom; it is available free of charge to INTIB national focal points and marketed at special rates for other centres in developing countries (G.3.1.03(ii),(v),(vii)).

31. INTIB has drawn up, with the co-operation of the Government of France, the first of a series of directories on sources of industrial and technological information. This first directory permits the rapid identification of more than 50 organizations in France capable of replying to a precise inquiry, whether it concerns a raw material, a technology, a supplier, a potential partner, a product or a production process (G.3.1.03(iv)). Three volumes of the Industrial Development Abstracts series (G.3.1.03(i)) and a number of information packages in selected sectors were published, while only two issues of the INTIB newsletter INTIB Net could be issued, owing to financial constraints (G.3.1.03(viii)). Similarly, restrictions on consultancy made it impossible to produce several other publications planned for 1990. Guidelines for setting up a modern information processing system for small- and medium-scale industrial enterprises were prepared and disseminated among such enterprises and INTIB network participants. The Industrial Energy Conservation Abstracts (INECA) Journal was launched; it contains information collected through network activities, concentrating on energy conservation technical reports and technologies (G.3.1.01(v)).

32. Assistance was provided to developing countries in the acquisition and negotiation of technology and related policy responses. A fresh impetus was given to the Technological Information Exchange System (TIES), to intensify the collection and dissemination of information on technology transfer and negotiation issues, and to modernize and expand the scope of the TIES data base (G.3.2.01(vii),(x)). Monographs on the regulatory rules and practices on technology acquisition in developing countries and a volume of model forms of transfer of technology agreements were prepared for publication (G.3.2.01(iii)). A number of countries received direct assistance to improve their institutional capabilities in this area, e.g. Ethiopia, Nepal, Nigeria and Tunisia (G.3.2.01(i),(xi)). TIES activities in Africa, carried out in co-operation with the African Regional Centre for Technology, have been especially adapted to the needs of the African countries and have given a strong focus to the training of negotiators in the region (G.3.2.01(xii)). Educational activities on the acquisition and negotiation of technology were the subject of a continuing promotional effort. Three additional modules of a manual on technology transfer negotiations were prepared and put to practical use in a regional workshop organized in Egypt (under the African-TIES programme) and in Cape Verde (G.3.2.01(xi),(xii)). The Technology Advisory Services programme

continued to provide assistance through field missions and through a desk service operated from Headquarters. Advisory services were also provided to participants in investment promotion forums (G.3.2.02).

33. Work related to basic technologies centred on innovative areas to support the development, improvement and utilization of the technological capabilities of developing countries. In that context, programme concepts were formulated for technology management, technology and financing, industrial incubators and technological parks. Related activities included: a seminar on industrialization through standardization and quality control, held in Thailand in January; a technology management programme prepared for the Comisión Latinoamericana de Ciencia y Tecnología; an assessment of the potential for the establishment of technological parks and industrial incubators in Chile; a national technology programme prepared for Colombia together with COLCIENCIAS; and a workshop on the development and establishment of a Latin American Technology Market, which was held at Lima, Peru, in October in co-operation with the Latin American Association of Development Financing Associations (ALIDE) (G.3.3.02-G.3.3.03).

34. Concerning technologies for small-scale industries, technical co-operation between partners in China, the Netherlands and Thailand was ongoing for the development and utilization of appropriate technologies in the food sector. The third phase of a biomass energy project was under way in Zimbabwe: the gasification technology applied in that project will be promoted by demonstrating its application in other countries, especially in the Preferential Trade Area for Eastern and Southern African States (PTA) subregion. A technical summary of a manual on small hydropower technologies was finalized in English, French and Spanish. An evaluation was undertaken of existing equipment for a mini-hydropower plant in Ghana and the appropriate site for its installation identified. A study on technologies for conventional materials in Africa was completed. Projects were also formulated for the development of local technologies in Niger and for the identification and promotion of local technologies in Burkina Faso. A programme on technology capabilities in Africa was prepared as a follow-up to the 1989 Forum on Appropriate Industrial Technology for Africa 8/ (G.3.3.01).

35. Under the special technologies programme, a number of activities were aimed at the improvement of the manufacturers' technology through a mechanism of feedback from the end-users. To achieve this, a number of promotional meetings were

8/ *Ibid.*, para. 35.

organized between manufacturers and end-users. More than 20 agreements were concluded between licensors and licensees in China, Germany, Poland, Republic of Korea and the Union of Soviet Socialist Republics. An information network was established to continue the promotion of such agreements (G.3.4.02). Publications under this programme were delayed due to lack of funds (G.3.4.01).

36. With regard to the promotion of cleaner, safer and energy-saving technologies, projects were initiated, ranging from clean technology in the steel industry in Latin America and Asia to a rehabilitation plan for water resources in an African country. Technical, scientific and managerial personnel from several developing countries were provided with support to attend international training workshops, conferences and seminars on the latest strategies and technologies for optimal management of industrial by-products and environmental resources. Seven technical reports were prepared and distributed dealing with hazardous waste management, economic incentives for clean technologies, legislative and clean technology guidelines, and safety aspects (G.3.5.02).

#### INDUSTRIAL INVESTMENT PROGRAMME

37. With the restructuring that went into effect at the beginning of 1990, <sup>9/</sup> the industrial investment promotion programme steadily expanded during the year. The promotion of 170 industrial investment projects was successfully concluded (1989: 143). This amounted to a total investment of \$699 million (\$556 million in 1989). The value of technical co-operation activities rose from \$5.5 million in 1989 to \$8.4 million in 1990 (which includes the operations of the Investment Promotion Services network).

38. Fundamental to the development of the industrial investment programme was the Investment Promotion Services (IPS) network. During the year, support was extended to the nine existing IPS offices and negotiations were undertaken with the Governments of Czechoslovakia, Greece, the Islamic Republic of Iran, Portugal and Turkey to establish IPS offices in those countries. Within the IPS operation, the delegates' programme continued to prove a particularly effective tool in fostering UNIDO investment promotion endeavours. In 1990, this programme generated an estimated \$202 million of foreign investment in developing countries. During the year, 32 participants from 16 developing countries took part in the programme (Africa 3, Asia and the Pacific 23, Latin America 5

and Europe 1). On-the-job orientation programmes were organized by the IPS offices for the participants, who included officials from national investment promotion agencies. The success of the delegates' programme is reflected in the variety of its funding sources: IPS financing, bilateral (from developed and developing countries) as well as UNDP financing.

39. Concerning the Africa programme (G.1.1), a Regional Forum for Promotion of Industrial Investment Projects was held in June for 16 member countries of the Preferential Trade Area for Eastern and Southern African States (PTA), sponsored by UNIDO and the PTA Secretariat, at Nairobi, Kenya, in co-operation with the Commonwealth Secretariat and the Centre for Industrial Development of the European Community. A total of 179 investment projects were identified and promoted for bilateral discussions at the Forum, which was attended by about 600 participants. Assistance was also extended in the preparation and execution of the investment project promotion forum for the Economic Community of West African States held at Dakar, Senegal, in December (G.1.1(v)). Technical assistance was provided to the Zambian Confederation of Chambers of Commerce and Industry to improve its investment project identification and formulation capability and the design and development of a data base system similar to the Investment Promotion Information System (INPRIS) of UNIDO. Similar assistance was extended to the Uganda Manufacturers Association and the Uganda National Chamber of Commerce and Industry, while a draft of an investment act was prepared for the Government of Zambia. In Kenya, an integrated programme was launched to strengthen the Investment Promotion Unit serving the Ministry of Industry, the Kenya National Chamber of Commerce, the Kenya Association of Manufacturers and the Industrial Development Bank of Kenya. Furthermore, a start was made in identifying investment projects for implementation of a programme in Nigeria, which will include the convening of an investment project promotion forum in 1991 (G.1.1(iii)). In other African countries, activities focused on the building materials sector. In Zaire, 10 co-operation agreements between local entrepreneurs and European partners were concluded in the brick industry while pre-investment studies were undertaken also in the building materials sector in Cameroon, Senegal and Zaire, which led to the promotion of 10 investment projects in the wood industry (G.1.1(i)). Investors' guide books for Zambia and other PTA countries were prepared (G.1.1(ii)). A round table of major aid agencies in Africa was convened in June (G.1.1(vi)). During the year, 52 investment projects were successfully concluded in Africa to a value of \$138 million (G.1.1(iv)) and technical co-operation projects valued at \$0.6 million were implemented (G.1.1(i)).

<sup>9/</sup> *Ibid.*, para. 38.

### Investment projects concluded in 1990, by region

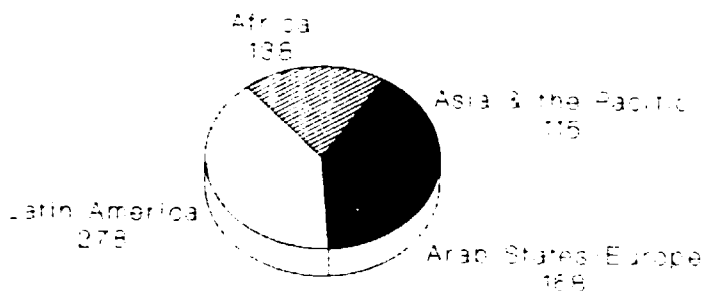

(in millions of US dollars)

### Investment projects concluded, 1986-1990

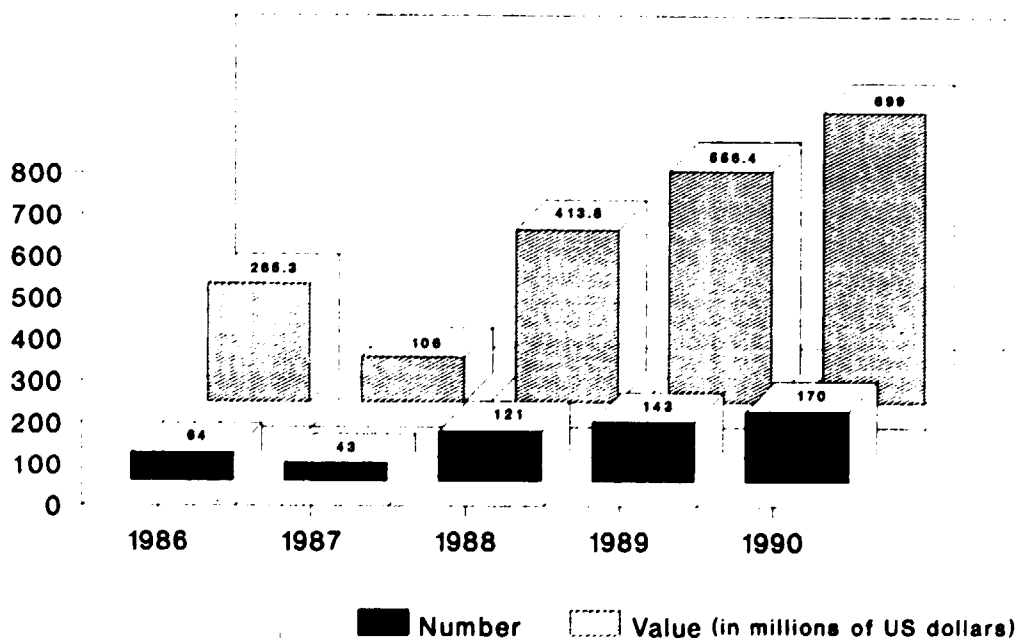

40. For the Asia and Pacific region (G.1.2), as in 1989, 10/ advantage was taken of promotional events in Europe to assist project sponsors from developing countries. Thus, UNIDO arranged for 40 entrepreneurs from China and member countries of the Association of South-East Asian Nations to attend Interpack, the industrial fair on packaging, held at Duesseldorf, Germany, in June. In Viet Nam, 187 industrial investment projects from 15 industrial subsectors were prepared and promoted by UNIDO. Vietnamese Government delegations attended country presentation and investment promotion meetings in Australia, Austria, France, Germany, Hong Kong, Italy, Japan and Sweden in an effort to encourage the attendance of potential investors at the investment forum scheduled to take place in March 1991 at Ho Chi Minh City. Preparations continued for another investment forum, scheduled for February 1991 at Colombo, Sri Lanka. For that event a total of 50 industrial investment project profiles were elaborated and promoted through the IPS network; country presentations and investment promotion meetings took place in Austria, Belgium, Germany, Italy, Japan and the Netherlands. Participants of Sri Lanka at those meetings included senior officials of the Greater Colombo Economic Commission, the Chamber of Commerce and banks as well as private entrepreneurs. Investors' guide books for Sri Lanka and Viet Nam were prepared (G.1.2.(ii)). In August, UNIDO and the Economic and Social Commission for Asia and the Pacific began implementation of an integrated programme for the identification, formulation, screening and promotion of 50 to 75 investment projects for Nepal. An industrial investment programme, including a review of the investment laws and regulations of the Democratic People's Republic of Korea, was implemented in close co-operation with the United Nations Centre on Transnational Corporations. Nine investment project profiles were elaborated and screened for further promotion (G.1.2.(iii),(iv)). In 1990, 32 investment projects were successfully concluded in the Asia and Pacific region to a value of \$115 million (G.1.2(iv)) and technical co-operation projects valued at \$1.2 million were implemented (G.1.2(i)).

41. In the Arab countries (G.1.4), 33 investment opportunities in electronics were identified through a joint UNIDO/ESCWA programme implemented in co-operation with the Algerian High Commission for Research (G.1.4(iii)). The First Arab Investment Forum for Electronics, held at Algiers in May, provided an opportunity for discussions between potential business partners (G.1.4(iv)). Assistance to the Gulf Organization for Industrial Consulting continued with the preparation of a new series of techno-economic investment profiles for a range of manufacturing processes. A proposal for a regional industrial investment

programme for the countries of the Arab Maghreb Union (AMU) was formulated for submission to the AMU secretariat and UNDP (G.1.4(i)).

42. In the Europe and Mediterranean region (G.1.4), an investment programme for Poland was carried out in co-operation with the country's Foreign Investment Agency. Some 250 investment projects were identified and promoted in preparation for the Second Investors' Forum for the Promotion of Foreign Investment held at Warsaw, Poland, in May. The programme was financed by the Polish Government and by funds in trust provided by an international consulting firm, which also assisted in promoting the interest of potential foreign partners in countries with no IPS offices. An industrial investment programme was also implemented for Yugoslavia. More than 100 investment opportunities were identified and promoted, culminating in the Investment Forum for Yugoslavia held at Belgrade in October 1990 (G.1.4(iii),(iv)). A programme to assist the State Planning Organization of Turkey in promoting foreign investment was approved by UNDP. The programme will also enable the State Planning Organization to join the INTIB network (see para. 29 above) (G.1.4(i)). Investors' guide books for Poland and Yugoslavia were prepared (G.1.4.(ii)). In 1990, 21 investment projects were successfully concluded in the Arab countries, Europe and the Mediterranean region to a value of \$168 million (G.1.4(iv)) and technical co-operation projects valued at \$0.1 million were implemented (G.1.4(i)).

43. A number of investment promotion programmes already undertaken at the country level 11/ in the Latin American and Caribbean region continued to be expanded (G.1.3). In Bolivia, in a UNDP-financed programme, 180 investment projects were identified, of which 80 are under promotion. A unit was established to identify, formulate and promote investment projects, and the staff of the unit were trained in those skills. In October a meeting was held in Bolivia on co-operative arrangements among selected partners on specific projects, at which letters of intent were signed with a total value of \$72 million; the meeting also led to other types of agreements on various activities to an amount of \$164 million. An investors' guide book for Bolivia was prepared (G.1.3(ii)). The first phase of the programme for the Dominican Republic was concluded by identifying and formulating 23 investment projects, currently under promotion, with special emphasis on partners in the Asia and Pacific region. To improve project evaluation skills, assistance was given to the country's Council for Investment Promotion by providing computer hardware and the services of the UNIDO Project Profile Screening and Pre-Appraisal Information System (PROSPIN) software

10/ *Ibid.*, para. 40.

11/ *Ibid.*, para. 43.

package. The first phase of a programme for Venezuela was concluded with the holding of workshops on the identification and evaluation of investment projects and the identification of 35 projects for discussion between potential local investors and foreign partners. In Ecuador, promotion continued of projects already identified, and several agreements were finalized between international and local promoters, including the development of projects with non-traditional financing features. Assistance to the Secretaria de Comercio y Fomento Industrial of Mexico for the establishment of a data base on investment activities was completed, and preliminary discussions were initiated for an industrial investment programme for Mexico. Preparatory assistance in investment promotion was undertaken for Argentina, Barbados, Cuba, Haiti, Jamaica, Paraguay, and Trinidad and Tobago. At the regional level, a concept paper was prepared for a joint programme between UNIDO, the Caribbean Community and the Caribbean Development Bank to develop a regional investment programme for the Caribbean countries. Also, discussions continued with ALIDE for the implementation of the second phase of the co-operation between UNIDO and ALIDE to identify projects originating from development financing institutions in Argentina, Brazil and Uruguay. 11/ A joint UNIDO/ Andean Development Corporation (CAF)/UNDP regional programme was initiated for the Andean countries (G.1.3(i),(iii)). In

the Latin America and Caribbean region 65 investment projects were successfully concluded to a value of \$278 million (G.1.3(iv)) and technical co-operation projects valued at \$1.0 million were implemented (G.1.3(i)).

44. UNIDO maintained its sectoral approach to investment promotion during the reporting period. This was largely concentrated on the agro-industry sector in a programme involving the French authorities and the International Finance Corporation. During the ongoing operational phase of the project, in 1990 additional identification missions were undertaken to Czechoslovakia and additional investment projects were identified in Bolivia and Poland through investment promotion meetings 12/ (G.1.5.01(i)).

45. The tools available for the efficient implementation of the industrial investment promotion programme continued to be developed. A review of the software packages, PROPSPIN and INPRIS resulted in (a) a more user-friendly version of PROPSPIN which will be released, together with literature for training purposes, early in 1991 after thorough testing in the field and (b) a proposal on the future development of INPRIS and related data bases, to be implemented in 1991 (G.1.5.01(ii)).

---

12/ *Ibid.*, para. 44.

## CHAPTER IV. SPECIAL THEMES

### INDUSTRIAL DEVELOPMENT DECADE FOR AFRICA

1. The General Conference allocated \$8.6 million for the biennium 1990-1991 to the two main components of the Industrial Development Decade for Africa (IDDA) programme - \$3.85 million for technical co-operation projects and \$4.75 million for supplementary activities, the latter comprising policy support and programming work. For the technical co-operation component, the Secretariat took concerted action to programme the timely use of the funds. In 1990, 32 projects were approved, amounting to \$4.66 million, of which \$1.97 million was implemented. The supplementary activities component for 1990 included: the preparation of integrated subsectoral programmes with the emphasis on agro-related industries; the organization and substantive servicing of a subregional meeting to promote industrial co-operation for North Africa, held at Tunis, Tunisia, from 6 to 7 October; preparations for a meeting for the Eastern and Southern subregion, to be held at Kampala, Uganda, in March 1991; sponsoring the Regional Investment Forum of the Preferential Trade Area for Eastern and Southern African States (PTA) held at Nairobi, Kenya, in June (see chap. III, para. 39); and the "Industrial Partners Programme for Africa", which aims at creating opportunities for joint ventures between African promoters and members of the business communities of the south-eastern United States of America (E.2.8.02(iii),(iv),(xii)). The supplementary activities have also included short-term technical advisory services that are used to provide policy and programming assistance to countries upon request (E.2.8.02(v)).

2. A major activity was the preparation of the programme for the Second IDDA, which included the "Framework and guidelines for action at the national and subregional levels for the preparation of the programme for the Second Industrial Development Decade for Africa (1991-2000)" (PPD.161). This document, which was elaborated jointly with the secretariats of the Organization of African Unity (OAU) and Economic Commission for Africa (ECA), emphasizes the basic principles and the twin objectives of the Second IDDA - self-reliant and self-sustaining industrialization at the national and subregional levels. Copies of the document were sent to all African countries and subregional organizations with a detailed tentative schedule prepared by the OAU, ECA and UNIDO secretariats as a guide in carrying out activities proposed in a timetable set out by the Conference of African Ministers of Industry at its ninth meeting. The activities in the timetable include the preparation of national and

subregional programmes. On the basis of these, the three secretariats will prepare a draft programme for the Second IDDA which is to be finalized by a special working group of governmental experts and submitted for adoption to the Conference of African Ministers of Industry at its tenth meeting in June 1991. A joint progress report by the secretariats of OAU, ECA and UNIDO on the preparations for the Second IDDA programme was submitted to the United Nations General Assembly through the Economic and Social Council 1/ and an updated progress report was submitted to the Board in September 1990 2/ (E.2.8.02(x)).

3. Governments were requested to establish a national multidisciplinary working group that would draw on all sectors of society to prepare the national programmes, and to nominate a co-ordinator who would be responsible for programme preparation and implementation. Assistance was provided by UNIDO and ECA to countries and subregional organizations in the preparation of their respective programmes for the Second IDDA. UNIDO earmarked \$883,900 for that purpose. Expert missions were fielded to 26 African countries, while other countries were assisted by experts of relevant ongoing UNIDO projects, in co-operation with the national experts financed by ECA.

4. As part of the efforts to mobilize fuller financial and technical support for the Second IDDA and in order to ensure effective co-ordination of the IDDA programme with other multilateral and bilateral programmes and activities, UNIDO initiated consultations with development assistance institutions and United Nations organizations such as the World Bank, the United Nations Development Programme, the African Development Bank, the European Development Fund, the Food and Agricultural Organization of the United Nations and the United Nations Conference on Trade and Development and forwarded copies of the "Framework and guidelines for action" to them for comments. Based on the positive responses received, UNIDO is preparing a consultative meeting to be convened in 1991 for the purpose of involving those institutions in the work of the programme for the Second IDDA.

5. Many activities forecast for 1990 under programme element E.2.8.02 were postponed owing to a difficult cash-flow

---

1/ A/45/257.

2/ IDB.7/25.

situation, e.g. organization of a meeting of the constitutive assembly of the African Iron and Steel Association (vi); the conduct of five country and subregional programming exercises (vii); preparation, by the Programme Development Support Unit, of five integrated sectoral and sub-sectoral programmes (see chap. II, para. 55) (viii); organization of national and subregional workshops on long-term industrial development in Africa (ix). Of the 12 industry-wide programming studies at the national, subregional and regional levels that were forecast for the biennium, three were completed and preparatory work was finalized on another five (xiii).

### ASSISTANCE TO THE LEAST DEVELOPED COUNTRIES

6. On 1 January 1990, the coverage of individual least developed countries (LDCs) was integrated into the respective regional programmes for Africa, the Arab countries, Asia and the Pacific, and Latin America and the Caribbean. Together with the re-integration of programming activities into the geographical areas, a senior post of Co-ordinator for LDCs was established through redeployment (E.2.8.03). The functions of the Co-ordinator include, among others, monitoring and following up UNIDO activities in LDCs, strengthening UNIDO contacts with other United Nations agencies dealing with LDCs, organizing national and regional workshops for LDCs on project identification, design and evaluation in priority areas, and developing an information system for LDCs. Concurrently with the establishment of the LDC Co-ordinator office, special regional programmes with emphasis on LDCs were created for the Arab countries and for Asia and the Pacific.

7. In accordance with Board decision IDB.6/Dec.6, UNIDO actively participated in the Second United Nations Conference on the Least Developed Countries held in Paris from 3 to 14 September 1990 as well as in the preparatory activities which preceded that event. The Conference adopted the Paris Declaration and a Programme of Action to accelerate the development process in LDCs during the 1990s, which includes references to industry and UNIDO.

8. As follow-up to the Paris Conference, financing was obtained from the Government of Italy for a project aimed at the preparation of an industrial action plan for LDCs. The purpose of the project is to collect and analyse key development issues related to the industrialization of LDCs and prepare recommendations for national and international action in this field. Activities under this project include the holding of an international workshop on national and international strategies for industrialization of LDCs in 1991 to enable UNIDO to finalize the industrial action

plan, which would be submitted to the fourth session of the General Conference in November 1991.

9. As for operational activities, UNIDO fielded missions to 30 LDCs in all regions in conjunction with the preparation for the fifth United Nations Development Programme (UNDP) country programming cycle and with the programme, sectoral and mid-term reviews. Inter-agency co-operation activities for the benefit of LDCs were also intensified.<sup>3/</sup> Preparations began on integrated industry sector programmes for all LDCs in Africa. New approvals generated for LDCs in 1990 amounted to \$16.68 million (1989: \$15.05 million) representing 126 projects mainly in such priority areas as development of industrial services, human resource development, rural development, industrial promotion and investment. A total of 34 out of the 42 LDCs benefited from UNIDO technical co-operation during the year. Net approvals amounted to \$26.35 million (1989: \$21.12 million) while delivery reached a level of \$22.05 million (1989: \$22.34 million).

10. A seed programme for LDCs was initiated to promote the traditional textile industry in Africa, a sector that has great potential. Recognizing this, the Government of Japan has offered to finance this activity from its trust fund. A regional workshop on the development of the agro-related metalworking sector was carried out for LDCs within the framework of the Special Programme for the Industrial Development of Asia and the Pacific.

11. Owing to cash-flow problems, the three workshops forecast in programme element E.2.8.03(i) on the identification, design, appraisal, monitoring and evaluation of technical co-operation projects had to be postponed. One of them, intended for the African English-speaking LDCs, will be held in May 1991 in Malawi, while the other two, for the African French-speaking LDCs and for Asian LDCs, were postponed.

12. Activities and projects under the framework of economic and technical co-operation among developing countries (ECDC/TCDC) continued to interest a number of LDCs and were carried out at regional, subregional and interregional levels. A Solidarity Ministerial Meeting was held in Ethiopia in November (cf. para. 13 below). As a follow-up to previous ECDC promotional activities, selected projects were implemented for the benefit of Bangladesh, Burundi, Cape Verde, Guinea and Niger. Within the framework of the Industrial Development Decade for Africa, one third of the programmable budget has been allocated to projects devoted to LDCs at national, regional and subregional levels.

<sup>3/</sup> IDB.6/10/Add.1, paras. 8 and 10.

## INDUSTRIAL CO-OPERATION AMONG DEVELOPING COUNTRIES

13. Development of programmes and projects for industrial co-operation among developing countries continued in 1990. One of the two Solidarity Ministerial Meetings planned for the biennium 1990-1991 (E.2.7.01(i)) was held at Addis Ababa, Ethiopia, from 26 to 30 November. As a result of intensive bilateral discussions between Ethiopian industrial promoters and industrialists from 12 invited countries, 46 preliminary agreements were concluded for projects mainly in the chemical, leather, textiles and engineering industries. Preparatory work began for the second Solidarity Ministerial Meeting to be held in Botswana in 1991. As a follow-up to the Solidarity Ministerial Meeting held at Conakry, Guinea, in December 1989, 4/ a delegation headed by the President of the Guinea Women Enterprises Association visited China in October and signed an agreement, with their Chinese counterparts, on the acquisition and installation of vegetable drying equipment for which China provided a grant; a Guinean industrialist visited Romania, Turkey and Yugoslavia for further discussions on implementation of agreed projects.

14. An interregional meeting on enterprise-to-enterprise co-operation was devoted to promoting industrial co-operation generally, rather than in a single sector as envisaged in the approved programme (E.2.7.01(ii)). Held in Cameroon, at Yaoundé, from 3 to 5 April, the meeting was attended by 13 participants from nine invited countries, 80 local industrialists, as well as representatives from financial institutions and international and regional organizations. Some 80 projects were examined, resulting in 12 signed letters of intent and five preliminary co-operation agreements.

15. The first of two new regional/subregional programmes to promote industrial joint ventures among enterprises (E.2.7.01(iii)) was a meeting for countries of the Arab Maghreb Union (AMU) held at Tunis, Tunisia, from 3 to 6 October. It was attended by some 50 participants from AMU countries (Algeria, Libyan Arab Jamahiriya, Mauritania, Morocco and Tunisia). Proposals were adopted on regional co-operation in industrial sectors such as mechanical industries, electronics and informatics, textiles and leather industries, agricultural machinery and agro-industries as well as an investment forum and sectoral exhibitions. The proposals are to be submitted to the Maghreb Council of Ministers of Industry for official endorsement before being presented to UNIDO within the framework of a programme for technical co-operation with the AMU countries in a wide range

of industrial sectors. Enterprise-to-enterprise co-operation among Islamic countries was pursued through a project assessment meeting held at Istanbul, Turkey, from 5 to 7 March and attended by 13 project sponsors from six Islamic countries (Bangladesh, Cameroon, Guinea, Mali, Niger and Somalia). 5/ The Federation of Pakistan Chambers of Commerce and Industry requested UNIDO to organize a similar joint-venture meeting, which is planned for October 1991, at Karachi (E.2.7.01(iii)). The programme on co-operative arrangements in engineering industries in Latin America (E.2.7.01(iv)) was postponed to 1991.

16. Of the six technical workshops planned as part of the programme (E.2.7.01(v)), one was implemented. An interregional workshop on industrial utilization of medicinal plants was held in China, from 15 to 23 October, and was combined with a study tour of Beijing, Tianjin and Shanghai. It also served as a preparatory meeting for a regional Consultation planned for 1992 or 1993, for which a number of subjects were recommended. Some 25 preliminary agreements outlining potential economic and technical co-operation were concluded, and recommendations were made for the industrial exploitation of medicinal plant resources in the areas of technical co-operation, regional co-operation and information dissemination. Two other approved workshops dealing with co-operation on production and application of machine tools among Arab countries (Rabat, Morocco), and process technologies of petrochemical industries (Cairo, Egypt), were postponed to 1991 due to the situation in the Gulf region.

17. Eight operational projects aimed at promoting technical co-operation among developing countries (TCDC) were implemented: technical studies on the establishment of an extraction unit for essential oils (India/Burundi), rehabilitation of a cereal mill (China/Niger), participation in a workshop on wooden boat-building (Trinidad and Tobago), training programme on petrochemical research and development (Turkey), technical study of a textile factory (Turkey/Bangladesh), visit by Chinese machine tool experts to their counterparts in machine tool manufacturing and research in India (E.2.7.01(vi)). As a follow-up to recommendations made by African telecommunications experts at Arusha, United Republic of Tanzania, in December 1989, a group of officials and entrepreneurs from PTA countries attended a workshop on telecommunications equipment manufacture and a study tour organized at New Delhi in September in connection with the fair "Electronics India '90" (see chap. III, para. 21).

18. Within the programme to develop mechanisms and services for industrial

4/ IDB.6/10, chap. IV, para. 16.

5/ IDB.6/10/Add.1, para. 19.



co-operation among developing countries, discussions were initiated through the Joint Brazil-UNIDO Committee with the aim of, inter alia, promoting co-operation between institutions and industrial organizations in Latin America and Africa (E.2.7.02(i)).

19. The first step was taken to establish another new service - a computerized data base for economic and technical co-operation among developing countries (ECDC/TCDC). A copy of the information referral system for developing countries' TCDC capabilities (INRES-South) was acquired from UNDP and an agreement signed to enable UNIDO to examine, upgrade and extend its industrial component. At the same time, countries with significant industrial TCDC capacities in the form of training, research and engineering consultancies were contacted to document these capabilities in versions of INRES-South maintained at national level (E.2.7.02(ii)). To promote the use of INRES-South in-house for sourcing project inputs, demonstrations were organized for UNIDO staff. This programme element (E.2.7.02(ii)) is expected to develop into an ECDC information service that will enable UNIDO and its field offices to match industrial and technological capacities and needs in developing countries and to promote co-operation among enterprises, organizations and institutions.

20. Work was initiated on an inventory of national industrial capabilities in Egypt that would provide information for the development of joint projects and various forms of industrial co-operation with other developing countries. Preparations were made for a similar inventory in Asia (E.2.7.02(iii)). A workshop on information systems on technologies and projects was held at Bled, Yugoslavia, from 18 to 20 April, and was attended by 25 participants from seven developing countries, regional institutions and international organizations. Conclusions and recommendations were adopted on a methodology for improving co-operation among developing countries in the exchange of information on technologies and projects (E.2.7.02(v)). Compilation and exchange of information on raw materials (E.2.7.02(vi)) was postponed to 1991 due to financial constraints.

21. In the area of co-ordination, monitoring and promotion of ECDC activities (E.2.7.03), a regulatory framework for a UNIDO-wide ECDC and TCDC programme in the 1990s was drafted and reviewed internally. The framework is intended to encourage greater use of ECDC and TCDC mechanisms in programming and project formulation, design and implementation. In the context of system-wide efforts to identify and overcome some of the impediments to TCDC, programmes were being developed with countries having strong industrial TCDC capacities and a demonstrated commitment to TCDC. UNIDO maintained contact with regional economic commissions so as to

programme joint activities in the next biennium. The work of TCDC was promoted as a mechanism to feature strongly in the UNIDO special programmes for each developing region. The ICDC newsletter and brochures (E.2.7.03(ii)) were not initiated due to lack of staff resources.

22. As requested by General Conference resolution GC.3/Res.9, paragraph 6, and Board decision IDB.6/Dec.11, paragraph (c), UNIDO continued to intensify its efforts to recruit experts from developing countries for its technical co-operation projects. During 1990, 891 nationals from developing countries were recruited. They represent 36 per cent of all experts and consultants on contract during the reporting period. Included in this total number are 416 national professional project personnel. These figures confirm the trend during the past three years of an increasing proportion, both in absolute and relative terms, of developing-country nationals in UNIDO professional project personnel. The same is true of the UNIDO roster of experts which, as of 31 December, contained 4,281 nationals of developing countries, i.e. 33 per cent (1989: 31.8 per cent) of the total number of candidates (see chap. VII, table 4).

23. UNIDO continued its policy of increasing the use of the services of organizations, institutions and experts from developing countries. Efforts were also made to ensure that, to the maximum extent possible, bidders' lists included companies from developing countries (cf. chap. VII, para. 32). Similar efforts were made on the equipment purchasing side. Nevertheless, with developing countries needing increasingly sophisticated equipment, much of what they required was still not available in developing countries or, if available, often not serviced in those countries. Despite this, an improvement was again observed during 1990 (cf. chap. VII, para. 31) in the orders for equipment placed with vendors and manufacturers in developing countries.

#### INTEGRATION OF WOMEN IN INDUSTRIAL DEVELOPMENT

24. Implementation of the UNIDO Programme for the integration of women in industrial development during the medium-term plan period 1990-1995 and its plan of action for the biennium 1990-1991 was initiated mainly with financial support from the Government of Norway. Measures were designed to assure that women are explicitly targeted as participants and beneficiaries of UNIDO activities, in line with programme element E.4.5.01(i).

25. A reference kit for gender-sensitive project design and management was developed; it contains a set of guidelines for the consideration of women-in-development at different stages of the project cycle. As a first stage the kit focuses on the small-

and medium-scale industry sector, presenting recommendations, checklists and specific issue papers (e.g. on training, and credit) which aim to facilitate the participation of women in UNIDO projects in that sector and to enable them to benefit from these projects. In future, these guidelines will be applied during project appraisal and also be incorporated in the workshops on design and evaluation of technical co-operation projects. Subsectoral guidelines for the priority sectors of the UNIDO programme for women (agro-industries, human resource development, industrial planning and appropriate technology) will, in due course, be added to the reference kit. Country-specific information and data on women in industry derived from the data base on women in industry will be strengthened with support from the Government of the Netherlands and will supplement the reference kit (E.4.5.01(v)). A training programme on the integration of women in industry has been developed for both headquarters and field staff, and the reference kit will be used in the courses that are expected to start in early 1991 (E.4.5.01(ii)).

26. Measures were taken to ensure the consideration of the role and contribution of women to industrial development in UNIDO's preparation for industrial sector inputs to the UNDP fifth country programming cycle. For the first time, an expert on women-in-development was part of a team that is to carry out a review of the industrial sector, in Togo. The findings of the mission will be used to prepare the UNIDO inputs for the fifth country programme of Togo. Similar inputs are foreseen in other countries in which Governments have a definite policy on women-in-development. Other steps to assure the consideration of women-in-development in UNIDO activities include the attachment of an expert on the subject to a project in Mozambique that deals with the rehabilitation of small-scale industries and of a human resource specialist to the Regional and Country Studies Branch who is to institutionalize the consideration of women-in-development in study and research activities. A number of projects targeting women were designed and implemented (E.4.5.01(ii)) as illustrated below.

27. After having been field-tested in Zambia and Zimbabwe 6/ the manuals for the UNIDO training programme for women entrepreneurs in the food-processing industry have been finalized and are being distributed to interested institutions in developing countries. Preparatory missions have taken place to Mozambique and the Gambia to identify technical co-operation requirements for adapting and introducing the training programme in these two countries.

28. Exploratory missions were undertaken in Afghanistan and Nigeria. In Afghanistan, a one-year long technical co-operation project for women in textiles and handicrafts was designed. It is hoped that this proposal can be integrated into an ongoing UNIDO project on extension services for industrial serais (handicrafts centres). In Nigeria, two technical co-operation projects were formulated within the framework of the "Better life programme for rural women in Benue State". One project is a feasibility study for the establishment of a small- to medium-scale multi-purpose fruit and vegetable processing plant that aims to provide women vegetable and fruit growers with a steady income for their products. The other project deals with the upgrading of industrial production activities by rural women and aims at raising the productive capacity of four village production units (two palm-oil processing units, one gari production unit and one pottery production unit) and to strengthen and upgrade weaving and garment production at two women's resource centres in Benue State.

29. As a result of an exploratory mission to Kenya in December 1989/January 1990, a technical co-operation project was developed and approved that is aimed at enhancing the design and marketing capabilities of the "Jua kali" women manufacturers of textiles. Classroom and field training is expected to improve their entrepreneurial skills and their products range and quality and help them to expand the market for their products. It is expected that this project will show a multiplier effect when the graduate/trainees will, in turn, help more "Jua kali" women to meet the demands of the expanded markets.

#### CO-OPERATION WITH INDUSTRIAL ENTERPRISES AND NON-GOVERNMENTAL ORGANIZATIONS

30. The enterprise-to-enterprise co-operation programme, created as a response to UNIDO's mandate to co-operate more closely with the private and public sectors of industry, produced a high level of activity and co-operation between enterprises from developed and developing countries. Extensive discussions were held with industrial concerns and consulting companies (mostly from the United States of America, Europe, Japan and Australia) on ways to co-operate with suitable partners from developing countries (E.4.2.01). Based on these promotional efforts, a large number of individual companies as well as groups of industrialists visited UNIDO Headquarters to seek collaboration in identifying suitable industrial opportunities in the developing world. This UNIDO programme, which mobilizes resources for the support, inter alia, of private sector initiatives in developing countries, is seen by the industrial community as an excellent mechanism for private sector development and global co-operation.

6/ IOB.6/10, chap. IV, para. 27.

31. Many of the activities executed during 1990 were financed through voluntary contributions (mainly third party and self-financing trust funds) received from enterprises or their industrial federations and Governments for specific projects (see chap. VIII, paras. 22-29). For example, an Italian company co-sponsored a pre-feasibility study carried out by UNIDO for an Egyptian enterprise on the production of pharmaceutical raw materials. Another example is the Forum on the Promotion of Industrial Co-operation and Foreign Investment held in Yugoslavia in co-operation with the Ekonomski Institut, Belgrade. The Forum was supported both organizationally and financially by a well-known global auditing and management consulting firm. Further examples of this type of activity include: a seminar on coal gasification technology in China financed by a private enterprise from Germany; a UNIDO mission undertaken with Australian enterprises to the Democratic People's Republic of Korea to assist enterprises and organizations of that country in priority industrial sectors, which resulted in a number of projects for enterprise-to-enterprise co-operation in zinc and lead mining and processing, ore beneficiation, gold mining, the treatment and disposal of sewage and industrial waste water management; a self-financing trust fund agreement signed between UNIDO and the Government of the Democratic People's Republic of Korea for a large ore beneficiation project that will be financed through a commercial loan taken on behalf of a trading company in that country. In 1990, UNIDO services in the latter project included assistance in the procurement of equipment and in advising and negotiating the financial package with European banks.

32. A highlight of the enterprise-to-enterprise co-operation programme was the activities carried out by the UNIDO Centres for International Industrial Co-operation located at Beijing, China, and Moscow, the Union of Soviet Socialist Republics. <sup>7/</sup> Both Centres became fully operational in early 1990. Experts from Denmark and the Republic of Korea were assigned to the Beijing Centre, and from Japan and France to the Moscow Centre. The experts identified a large number of projects for co-operation between enterprises from their home countries and the Soviet Union and China. Possibilities are being explored to assign delegates from African countries to these Centres under individual financing arrangements from extrabudgetary resources, with the aim of promoting co-operation between China or the Soviet Union and the African countries involved (E.4.2.02).

33. Promotional efforts took an added impetus in the Latin American region, particularly in view of the policy changes taking place in many Latin American

countries leading to their industrial restructuring. UNIDO staff visited several countries in the region and identified projects at the enterprise level. At the same time, UNIDO staff met with leading enterprises and organizations particularly from the United States, Canada and Japan to promote enterprise-to-enterprise co-operation between companies in these countries and potential partners in Latin America (E.4.2.01).

34. Similarly, emphasis continued to be placed on furthering contacts with national and international non-governmental organizations (NGOs) because the experience, resources and the wealth of information available to them in all sectors of industry provide valuable perspective for the work of UNIDO and their support and participation is often a critical element in the implementation of UNIDO projects and activities (E.4.2.03). Support to industrial co-operatives and co-operative organizations was also a feature during 1990. An expert group meeting on Regional Co-operation among Latin American Industrial Co-operatives was held at San José, Costa Rica. The meeting, which was organized in close collaboration with the International Co-operative Alliance, was centred on a strategy to further the development of industrial co-operatives in that region. A study was prepared on the uses of debt-conversion mechanisms by NGOs to help provide for the capital needs of small enterprises and industrial co-operatives. The convening of a meeting on this subject during 1991 is being considered.

35. The Industrial Partnership and Co-operation for Development Scheme (IPAC), which is entirely funded by a donor country through a contribution to the Industrial Development Fund, has proved to be an important mechanism for responding quickly to urgent requests, particularly from small industries. The IPAC scheme has also strengthened UNIDO co-operation with several associations of retired executives, especially those in Austria, France, Germany and the Netherlands. Under the IPAC scheme, 57 projects were implemented including provision of experts, training, and supply of equipment for pilot projects. Private and public sector enterprises from all regions benefited under the programme (E.4.2.01 and E.4.2.03).

36. At its sixth session the Industrial Development Board granted consultative status to four international non-governmental organizations, bringing to 85 the number of organizations having consultative status with UNIDO.

## ENVIRONMENT

37. While UNIDO had for some time been engaged in incorporating environmental aspects into its activities, and environment and energy together comprise one

<sup>7/</sup> *Ibid.*, para. 34.

of the priority areas in the 1990-1995 medium-term plan. 8/ in June, by decision IDB.6/Dec.7, the Board approved the UNIDO environment programme outlined in document IDB.6/3. Subsequently an Environment Co-ordination Unit (ECU) was established on 1 July 1990 (UNIDO/DG/B.133), and in August, two Professional and three General Service staff members were redeployed to ECU. The Unit was charged with initiating, co-ordinating and managing the implementation of the environment programme, as well as translating into industry-related environmental policies and strategies the decisions and resolutions adopted by policy-making bodies of UNIDO and other organizations of the United Nations system, taking into consideration the needs and priorities of the developing countries.

38. The first subprogramme of the environment programme stresses the importance of training, which was among the initial activities of the new Unit. A high priority is the training of UNIDO staff so they may provide more effective and environmentally sound industrial technical co-operation. Under the guidance of a seconded official from the United States Environmental Protection Agency, attached to ECU, a programme of staff training was undertaken comprising a broad range of environmental topics. As a result, a course on environmental issues for Headquarters staff was conducted six times during the latter half of 1990. In addition, a monthly series of environmental awareness seminars was organized. Another environment awareness-raising initiative designed to sensitize staff to the problems of environment and industry and to keep them apprised of UNIDO's efforts, is the Environmental Awareness Bulletin, a compendium of environmental news, reports and sources of information originating both inside and outside the Organization. The Bulletin is distributed in-house and to Permanent Missions at Vienna.

39. In approving the environment programme, the Board instructed UNIDO to consult with Member States to determine guidelines for UNIDO's preparation for and participation in the United Nations Conference on Environment and Development, to take place in Brazil in June 1992. As a contribution to the United Nations Conference, a project was developed and the financing of over \$1 million was approved under a Danish special-purpose contribution to IDB for the holding of an international conference on ecologically sustainable industrial development. The Conference, which will be hosted by the Government of Denmark, will be held at Copenhagen in October 1991. Participation will be at a high level, bringing together senior government officials, representatives of industry, intergovernmental and non-

governmental organizations, and other organs and organizations of the United Nations system to discuss the role of industry in achieving sustainable development. The recommendations made at the Conference in 1991 are expected to be a major input into the 1992 United Nations Conference. UNIDO is co-operating closely with both the 1992 Conference and UNEP secretariats in this endeavour.

40. In addition to participation in the Conference in Brazil, UNIDO activities form an integral part of the ongoing United Nations System-wide Medium-term Environment Programme 9/ and UNIDO is also a member of the Designated Officials on Environmental Matters of the Administrative Committee on Co-ordination. UNIDO and UNEP co-operate closely on several levels. Technical and promotional activities, such as preparation of sectoral guidelines, are carried out with the Industry and Environment Office of UNEP in Paris. One important activity conducted with the active participation of that Office was a workshop held in Paris in December as part of the first phase of a regional Africa Programme on purification of industrial waste water, financed by the Swedish International Development Authority. Representatives of seven eastern African nations examined problems and solutions in five industrial sectors, and specific recommendations for the next phase aimed at promoting cleaner production in those sectors. Other proposals included holding industrial workshops, training pollution control officers, upgrading industrial laboratories and developing national reference laboratories, defining effluent standards, and conducting environmental audits for small and medium-size plants. UNEP has also agreed to co-sponsor three courses to be offered during 1991 from the UNIDO programme of the International Centre for Genetic Engineering and Biotechnology. While informal agreements with UNEP are in force, a memorandum of understanding is being prepared that will formalize relations and determine future areas of collaboration.

41. Advisory services for developing countries will play an important role in the UNIDO work programme. Work therefore started on the development of guidelines and procedures for integrating environmental aspects into all UNIDO technical co-operation activities. Systems are being examined by which environmental components of projects can be identified readily and quantified. This will permit closer monitoring of the environmental element in projects, an exercise that will prove valuable for internal use and for reporting to governing bodies. In undertaking this effort, close co-operation is expected both in-house as well as with other United Nations organs and organizations.

8/ IDB.5/10, chap. III, paras. 164-169; IDB.6/10, chap. III, paras. 179-185.

9/ UNEP/GCSS.1/7/Add.1.

42. In response to UNIDO's efforts to expand environment-related industrial technical co-operation, several countries provided additional, special-purpose contributions. The Governments of Norway and Sweden contributed to IDF for projects to be developed under the environment programme, and the United States seconded a cost-free expert for one year to work with ECU (see para. 38 above).

43. A total of 75 environment-related projects were under implementation during the year and an equal number were in the pipeline. Examples of countries in which large-scale environment-related projects were under way were Bulgaria, China, Hungary, India, Madagascar, Nigeria, Paraguay, Viet Nam, Yugoslavia, and Zimbabwe. Examples of donors financing such projects are China, Czechoslovakia, Denmark, Germany, Japan and Sweden. Overall, most of the environment-related activities fell into the following areas: improvements in environmental conservation and management, institution-building, treatment of effluents from industrial activities, monitoring of air and water pollution, identification and treatment of hazardous wastes, formulation of guidelines and standards, industrial safety and risk assessment, and recycling and reutilization of industrial wastes. Assistance in effluent treatment from tanneries was under way in countries such as China, Ethiopia, Nepal, Pakistan and Viet Nam. Regional workshops on re-refining used lubricating oil were designed to introduce the latest technology to participating countries. Furthermore, under a project financed by Belgium, a pilot unit for the recycling of plastics was being set up in China. Through other projects, equipment and expertise were provided to several developing countries for treatment of industrial waste water. A workshop on pollution control and low-waste technologies in agro-based industries in selected Asian countries was held in China in September.

44. Work continued to develop methods for the integration of environment-related aspects in strategic management and planning as well as policy formulation. Activities included an Expert Group Meeting on Computer-aided Tools for Environmental Impact Assessment; a study on environmental assessment and management of the fish processing industry was updated and will be issued as a working paper. A project on environmental auditing at an aluminium plant in Bulgaria was finalized with an expert group meeting. The meeting concluded that in optimizing environmental, economic and social systems surrounding production, technological choices were made as a result of decisions on production and marketing strategies, social considerations etc., usually at a relatively late stage. Work on industrial management and rehabilitation has included the introduction of energy-related environmental protection measures. For example, under a

regional European project on an energy conservation network, mobile energy diagnostic units are being equipped with instrumentation to monitor the level of air and water pollution.

45. Group training programmes conducted in numerous countries - for instance on the preparation and appraisal of industrial projects and programmes - included consideration of the environmental impacts of new and rehabilitation investment projects. The environmental aspects are also taken into consideration in all of the 100 or so pre-investment studies carried out each year. In addition, work was under way to design integrated programmes to assess the viability of activities undertaken by individual countries for industrial waste management and energy saving.

46. Among studies conducted during the year, the UNIDO Global Report 1990/91 (ID/371) carried as its special theme the relationship between industry and the environment. As industrial stagnation would be a costly and probably ineffective remedy for environmental problems, recent pollution abatement policies were scrutinized in the light of available information on the technical and economic aspects of pollution. In another study, currently under preparation, the role of environmental policies in non-ferrous metals industries was being examined, with particular emphasis on the impact of government policies on international competitiveness. In addition, seven technical reports were published on such topics as hazardous waste management, economic incentives for clean technologies, and legislative and clean technology guidelines.

47. An increasing number of environmental queries were handled by the Industrial and Technological Information Bank (INTIB) during the year, and a special issue of the INTIB newsletter, INTIBNet, was devoted to industry/environment. Within INTIB, an in-house computer network and system of data bases was initiated that will give staff members access to environmental information from many sources and thus assist them in formulating projects and other activities. The sources include the International Environmental Information System (INFOTERRA) data base of UNEP and a major metallurgical data base, METADEX, which provides details on energy and environmental aspects in metallurgy (see chap. III, para. 30).

48. As in the past years, UNIDO sponsored the participation of persons from developing countries at international environment meetings such as a conference on pollution prevention in the United States in June and a symposium to demonstrate the operations of hazardous waste management facilities in Europe, which was held in Denmark in October.

## CHAPTER V. APPRAISAL AND EVALUATION

### Appraisal

1. During 1990, 521 projects were submitted for appraisal and appraisal memoranda were issued for 434 on their relevance, feasibility, and potential effectiveness (E.1.1.01). Of these, 21 per cent conformed with the guidelines on project design as submitted, 68 per cent required various degrees of reformulation after appraisal, and 11 per cent were the subject of divergent views between appraisal and the drafters of the project proposals. Appraisal memoranda were not issued for 87 projects partly because of the need for more adequate information from the field and a change of circumstances in the recipient country.

2. Although there was some improvement in the design of project proposals submitted for appraisal, their design continued to be hampered by poor problem identification at the outset - as confirmed by the findings of many evaluation reports. It was therefore necessary to insist that full information be provided from the field on the causes and effects of the problems to be addressed by a given project proposal. This is important not only for a simple project for equipment repair, but all the more so for large and complex programmes of an integrated nature. Special efforts have also been made through the appraisal process to ensure that specifications of counterpart institutions and their absorptive capacity are provided in order to allow for the design of projects with a sustainable effect in terms of development. Equally important has been the need to ensure that project proposals are not limited to engineering or technological considerations, but that they also consider the economic, commercial, social, environmental and other aspects of the problems addressed. The quality of UNIDO technical co-operation would benefit from a more comprehensive approach to project design.

3. The temporary alleviation of the staff constraints in 1990 (five Professional staff from six budgeted for the 1990-1991 biennium) helped to improve the quality of UNIDO appraisal activities. However, they continued to be limited to desk work owing to the lack of travel funds.

4. Two project design workshops were conducted in Nigeria in January and attended by 184 participants; plans were completed to conduct another four project design workshops in the field for the benefit of the least developed countries. In addition, 15 workshops or individual briefings were held in Vienna for the benefit of UNIDO secretariat staff, UNIDO Country Directors and Junior Professional Officers, also covering the sectoral programme approach

to project development. One workshop was also held in Vienna for representatives from Sudan responsible for multilateral technical co-operation.

5. Existing guidelines for project design were amplified and a first volume was completed of the Guidelines for Environmental Appraisal, covering the following industrial subsectors: tanneries and leather finishing, fertilizer, iron and steel, and selected agro-industries. These guidelines were presented to secretariat staff at five workshops. Specific guidelines were also developed to promote the inclusion of women in the design of projects supporting the rural and small-scale industries in developing countries (cf. chap. IV, para. 25).

6. The substantive assessment of selected categories of projects was carried out in order to determine main trends in technical co-operation and the extent to which UNIDO policy is translated into action at the operational level. The four assessments undertaken were: "Country Programme" et "Country Focus" - une Analyse des Programmes d'Assistance Technique de l'ONUDI dans huit pays d'Amérique Latine et d'Asie du Sud-Est" (PPD.165(SPEC.)); "Industrial Rehabilitation: UNIDO Policy and Field Operations Contrasted" (PPD.164(SPEC.)); "The Integration of Women in Industrial Development: UNIDO Policy and Field Operations in the Small- and Medium-scale Industry Sector" (PPD.173(SPEC.)); and "Analyse Statistique des Programmes d'Assistance Technique Financés et/ou mis en Oeuvre par l'ONUDI en Amérique Latine et dans les Caraïbes en 1988 et 1989" (PPD.149). In addition, the Project Review Committee established an internal working group to assess the achievements to date of the Organization's activities in the use of computer-aided tools in industrial planning (UNIDPLAN) (cf. chap. II, para. 120).

7. A closer interaction between Member States and UNIDO on design and appraisal criteria will provide a basis for improved quality of UNIDO technical co-operation. The concern with the quality expressed by some major donor countries to the Industrial Development Fund (IDF) was welcomed and will enable the further strengthening of the appraisal function and of its influence on the overall quality of projects. Several donor countries also contributed to the UNIDO project design and appraisal methodology by providing detailed information on their own design and appraisal criteria. These criteria will be used when considering projects identified for financing by a specific donor country. However, a common understanding of "quality" - a concept which by its nature cannot be defined in absolute terms - is still required amongst all parties concerned. This is expected to be an important aspect of appraisal work in 1991.

## Evaluation

8. The second in-depth evaluation of Headquarters programmes was carried out during 1990 (D.O.5.01(iv)) and was devoted to investment activities of UNIDO in compliance with Board decisions IDB.5/Dec.7, IDB.5/Dec.12 and IDB.6/Dec.14 as well as General Conference resolution GC.3/Res.19. The evaluation, which consumed a good deal of staff time, was financially supported by Germany and Switzerland under special-purpose contributions to IDF to cover costs for travel and consultants used for specialized advice. It centred on the activities of the Industrial Investment Division but also included other investment-related activities of UNIDO. The report suggests ways of concentrating in one organizational unit those investment-related activities which are dispersed throughout the Secretariat. It also highlights the need to strengthen Headquarters support to the Investment Promotion Service network and to increase investment activities in the developing countries.

9. The UNIDO internal evaluation system covers all large-scale technical co-operation projects (projects over \$150,000 or with a duration of 24 months or more) whether financed from UNDP or UNIDO-administered funds. Project performance evaluation reports (PPERs) provide signals to project management, recipient Governments and UNIDO staff on the qualitative achievements of projects and also serve as a reporting tool to donors. Often lessons can be drawn that may be applied in improving future project activities. The high volume of reports received was maintained: a total of 242 PPERs (234 in 1989) were received for processing by the evaluation staff and the respective technical branches responsible for project implementation.

10. With respect to expanding the evaluation system to include small-scale projects of less than \$150,000, a simpler format and follow-up mechanism have been proposed for that purpose. As implementation of such evaluation progresses, performance reporting to donors for purposes of accountability should improve. More importantly, the lessons learned from such reports will enable UNIDO to improve the effectiveness and impact of the many small projects it implements in developing countries.

11. As is the practice, an analysis was concluded of the in-depth and self-evaluations of the previous year (D.O.5.01(iii)). While over 60 per cent of the projects met objectives satisfactorily (although 17 per cent barely), design problems continued to affect 60 per cent of the projects under implementation. Quality-wise, UNIDO project delivery was, in general, satisfactory, but with room for improvement. Lessons learned from these evaluations were extracted and passed on to programming and operational departments for further application.

12. A record of 36 in-depth project evaluations were carried out in 1990 (D.O.5.01(ii)) as compared with 18 evaluations during 1989. An analysis of the 1990 evaluations will be carried out during the third quarter of 1991 to allow sufficient time to assess follow-up action to the recommendations made.

13. Aside from the programme evaluation of UNIDO investment activities, the Secretariat organized and participated in other programme level evaluations. This work included involvement in a UNDP/UNIDO mini-thematic study of metrology projects; the study is expected to lead to a programme advisory note to guide international officials and officials from developing country Governments in the design and implementation of those projects.

14. The Board (IDB.5/Dec.13(c)) and the General Conference (GC.3/Res.8) have called for an in-depth evaluation, at an appropriate time, of UNIDO activities in the field of human resource development. Given the complexity of the subject and the broad spectrum of UNIDO activities, the Secretariat organized and backstopped a pre-evaluation study financed by Germany to define the scope, the issues and methodological approach of the planned evaluation. The results of the study are under review and a decision to proceed with this major evaluation will be taken in early 1991. An in-depth evaluation of the Austrian group training programmes was also started late in 1990. This is a joint undertaking with the Austrian Government which is financing the study.

### Internal audit

15. An important role in the assessment of UNIDO programmes is also played by the Internal Audit Unit in the Office of the Director-General (D.O.3.01). Established in 1987, the Unit comprises two professional auditors, and reports to the Director-General. Financial regulation 9.1(d) and financial rules 109.14 and 109.39 define its mandate and an annual work programme is prepared in consultation with various organizational units prior to approval by the Director-General. Close liaison is also maintained with the External Auditors to co-ordinate audits to the greatest degree practicable and thus achieve the broadest possible audit coverage.

16. The work carried out by the Unit falls into three distinct categories: (a) audits of operational and support activities with emphasis on economy, efficiency and effectiveness; (b) obligatory audits of shared services within the Vienna International Centre where an opinion has to be expressed on the fairness of the financial statements, and (c) special management reviews, studies or investigations that have been requested or authorized by the Director-General. In 1990, 12 audit reports were issued and a comprehensive review was undertaken of issues related to the computerization programme.

## CHAPTER VI. CO-ORDINATION, FIELD AND LIAISON ACTIVITIES AND PUBLIC INFORMATION

### RELATIONS WITH GOVERNMENTS AND INTERGOVERNMENTAL ORGANIZATIONS

1. The external liaison activities of UNIDO cover relations with Governments, governmental and intergovernmental organizations and organs, organizations and specialized agencies within the United Nations system.

2. During 1990, Liberia and Myanmar became Member States of UNIDO; the Yemen Arab Republic and the People's Democratic Republic of Yemen merged into one single sovereign State called the Republic of Yemen, and the German Democratic Republic acceded to the Federal Republic of Germany, to form one single sovereign State. The membership of UNIDO as of 31 December 1990 thus comprised 151 Member States. As of 31 December, 117 Member States were maintaining Permanent Missions to UNIDO of which 74 were located in Vienna, 21 in Geneva, 14 at Bonn, four at Brussels, two in Rome and one each at Bern, and Paris. During the reporting period, 48 high-level governmental delegations including Heads of State, Prime Ministers and Ministers, visited UNIDO Headquarters, while the Director-General undertook 10 visits on behalf of UNIDO to Member States. Permanent Representatives from 29 countries presented their credentials.

3. Activities continued under the joint programmes or similar co-operation arrangements established with Bulgaria, Czechoslovakia, Hungary, Poland, Romania, Turkey, the Union of Soviet Socialist Republics and Yugoslavia as well as with the Council for Mutual Economic Assistance and the International Centre for Public Enterprises in Developing Countries (ICPE). The joint committees set up for the purpose of monitoring these programmes met in the case of Bulgaria, Hungary, Poland, Romania, Turkey, Union of Soviet Socialist Republics and ICPE. They reviewed the results of past activities and decided on future work programmes.

4. Co-operation and co-ordination with the existing 63 National Committees for UNIDO could not be strengthened as requested in Board decision IDB.5/Dec.8, owing to lack of financial resources.

5. A relationship agreement in accordance with Article 19.1 (a) of the Constitution was concluded with the Food and Agriculture Organization of the United Nations as well as a memorandum of understanding for co-operation with the International Trade Centre UNCTAD/GATT (ITC). In implementing the 1987 relationship agreement with the International Labour Organisation (ILO), negotiations for concluding a working

arrangement to further define the areas of co-operation between ILO and UNIDO reached the final stage and signature was imminent.

6. Relationship agreements were also concluded with five intergovernmental organizations in 1990 (see appendix J) thus bringing to 22 the total number of agreements concluded since UNIDO became a specialized agency. Negotiations for concluding further relationship agreements continued and a number of them were expected to be signed during 1991. The implementation of relationship agreements continued to be followed up through exchanges of visits between high-level officials from intergovernmental organizations and UNIDO staff.

7. At the multilateral policy-making level, co-ordination was pursued by participating in the United Nations General Assembly, the Economic and Social Council, the Administrative Committee on Co-ordination (ACC), the Committee for Programme and Co-ordination (CPC) as well as in the governing bodies of the specialized agencies. The first 1990 regular session of ACC was held in Vienna at the invitation of UNIDO; 26 participants met under the chairmanship of the Secretary-General of the United Nations, including the executive heads of specialized agencies and other senior officials of the United Nations system.

8. Considering that various other United Nations agencies and organizations are also mandated through decisions of their respective governing bodies to carry out industry-related activities, inter-agency co-ordination was aimed, as in the past, at ensuring maximum complementarity, to avoid duplication and consequent waste of resources. These activities included exchange of comments on medium-term plans and programme budgets, supply of information on study programmes and technical co-operation projects, joint programming and project formulation missions, exchange of visits by Headquarters staff and project personnel, as well as inputs to meetings organized by the United Nations system.

9. In 1990 42 volunteers from the United Nations Volunteer (UNV) programme were assigned to 19 various UNIDO-executed projects. The Deputy Executive Co-ordinator and the Recruitment Planning Officer, Recruitment Resources Division of UNV visited UNIDO to review current and future collaboration.

### UNIDO FIELD REPRESENTATION

10. Pursuant to the Memorandum of Understanding between the United Nations



**Table 1**  
**Distribution of UCD established posts**  
**(by region and source of funds)**

Region	Source of funds															
	UNDP				Operational budget				Voluntary contributions				Total			
	1987/1988/1989/1990				1987/1988/1989/1990				1987/1988/1989/1990				1987/1988/1989/1990			
Africa	5	7	8	11	7	5	5	5	1	1	1	-	13	13	14	16
Arab States	1	2	2	2	-	-	-	-	-	-	-	-	1	2	2	2
Asia and the Pacific	6	8	8	8	2	2	2	2	1	1	1	-	9	11	11	10
Europe	-	-	-	-	-	-	-	-	1	1	1	1	1	1	1	1
Latin America and the Caribbean	7	7	7	8	2	2	2	2	-	-	-	-	9	9	9	10
<b>TOTAL</b>	<b>19</b>	<b>24</b>	<b>25</b>	<b>29</b>	<b>11</b>	<b>9</b>	<b>9</b>	<b>9</b>	<b>3</b>	<b>3</b>	<b>3</b>	<b>1</b>	<b>33</b>	<b>36</b>	<b>37</b>	<b>39</b>

Development Programme (UNDP) and UNIDO of April 1989, 1/ the title of the Senior Industrial Development Field Advisers (SIDFAs) was changed to UNIDO Country Directors (UCDs) (cf. Director-General's Bulletin UNIDO/DG/B.128 of 2 April 1990). Also in accordance with that memorandum, UNIDO in January 1990 assumed the responsibility for the administration of the UNDP Sectoral Support Programme funds and for the personnel aspects of the UCD programme including the UCD budgets for local office costs and international travel costs. (E.1.2.01(i))

11. The distribution of UCD posts by region and source of funds is provided in table 1 above. Of the 39 posts established in 1990, five were vacant at the end of the year but candidates had been identified and were expected to report in early 1991. (E.1.2.01(i))

12. In accordance with Board decision IDB.4/Dec.10, a proposal for a long-term financing scheme for the UCD programme, including UNDP financing, was presented to the Programme and Budget Committee (PBC) in June and to the Industrial Development Board in November (IDB.7/12 - PBC.6/16). The document outlined two proposals for the financing of the UCD programme in the fifth programming cycle: one suggested increasing the number of UCDs by 1996 to 50 posts, the other to 44 posts. The Board considered document IDB.7/12 and PBC conclusion 1990/7 and adopted decision

IDB.7/Dec.19, in which it reaffirmed that the UNIDO field representation should remain fully integrated in the UNDP field offices, and that the system of sharing financing of the UCD programme with UNDP shall be maintained. It also requested the Director-General to pursue his consultations with UNDP to progressively increase the UCD posts and urged Member States to provide new or further voluntary contributions to the UCD programme.

13. The UNDP Governing Council in its decision 87/48 had requested the Administrator to undertake a review of the whole sectoral support programme and to report to the Council in 1990 on the nature and scope of UNDP support to the sectoral programmes of relevant specialized agencies of the United Nations system (including the financing of UCD) during the fifth programming cycle (1992-1996). The Administrator, however, requested that consideration of the review should be postponed until the June 1991 session of the Council.

14. In October 1990 a UNDP consultant visited UNIDO for consultations on UNIDO's inputs to the Administrator's review. The consultations had three main purposes: (a) assessment of the new working arrangements between UNDP and UNIDO since 1 January 1990 concerning the UCD programme; (b) consideration of the impact of the successor arrangements for support costs and technical support services; and (c) recommendations for the management of the programme. The outcome of the ongoing review will have a direct bearing on the sectoral support programme funds allotment

1/ IDB.6/10, chap. VI, paras. 12-13.

to UNIDO and the UNIDO operational budget funds for the fifth cycle, both of which provide financing for the UCD programme.

15. With regard to voluntary contributions to finance the UCD programme, intensive negotiations were undertaken with donor Governments (E.1.2.01(ii)). Contributions to the Industrial Development Fund for that purpose were received in 1990 from the Governments of Italy (\$500,000) and Germany (\$309,620).

16. In accordance with Board decision IDB.4/Dec.11 concerning the holding of biennial UCD regional meetings (E.1.2.01(iv)), one meeting was held in Bolivia from 17 to 26 August, which was combined with a seminar for the industrial and technological development of Bolivia. Representatives of several United Nations and regional organizations attended. Following an invitation from the Government of Japan a second meeting was held in Tokyo for the Asia and Pacific region from 1 to 6 October. The meeting was preceded by a seminar on the relations between UNIDO and the Government of Japan, with special emphasis on co-operation in the region. At both meetings UNDP participated actively at the level of Director of the Regional Bureaux.

17. During the year, visits were co-ordinated for 28 UNDP Resident Representatives and 39 UCDs (E.1.2.01(v)). At the request of UNIDO Headquarters, 25 UCDs represented the Organization at some 90 meetings (E.1.2.01(iii)).

18. As in the past, the Junior Professional Officers (JPOs) provided valuable support to technical co-operation and other programmes of UNIDO. Eleven donor Governments to the UNIDO JPO programme continued their support in 1990 (see table 2 below). The Government of the Netherlands continued to finance JPOs from developing countries in addition to its own nationals. A total of 71 JPOs, including eight nationals from developing countries, were on board during 1990; 40 were in countries with resident UCDs, 29 in countries covered by a non-resident UCD, and two in countries where there was no UCD coverage. During the year, 28 new JPOs began work and, by the end of the year, 16 further candidates had been submitted to UNDP for consideration, 5 of whom had been accepted to begin work in 1991. (E.1.2.01(i),(ii),(iii)).

19. Two briefing meetings for 22 new JPOs and two mid-assignment review meetings for 25 JPOs were held in Vienna (E.1.2.01(iv)). JPOs also carried out missions to destinations outside their regular duty stations either to consult with non-resident UCDs or to monitor UNIDO projects and participate in evaluation missions. They contributed to meetings organized by UNIDO in their countries of assignment and represented UNIDO as observers at meetings where representation by Headquarters staff or UCDs was not feasible.

Table 2

JPOs financed in 1990

Donor Government	Number
Belgium	3
Denmark	8
Finland	6
France	1
Germany	20
Italy	2
Japan	3
Netherlands	17
Norway	6
Sweden	4
Switzerland	1
<b>TOTAL</b>	<b>71</b>

## PUBLIC RELATIONS AND INFORMATION

20. Public information activities in 1990 took a programmatic approach, highlighting specific priority areas of the Organization's work. Despite financial constraints on publicity and insufficiency of staff with professional media experience, the Section aimed to generate information material tailored more closely to the interests of news media, Governments, non-governmental organizations, industry and the general public.

21. A pamphlet reflecting the environmental concerns in the medium-term plan, Towards Sustainable Industrialization, was produced in English, French, German and Spanish to mark both United Nations World Environment Day and Earth Day. Working with Private Industry - a flyer in English, French and Spanish - explains the advantages of special trust-fund schemes as well as their complementarity to the industrial investment programme. A booklet, Women Considered, emphasizes the role of women in industrial development.

22. Some 80 press releases, information and publication notes were produced as well as the continued production of the quarterly illustrated newsletter UNIDO Update in English, French and Spanish. As in previous years, written press coverage was provided for major UNIDO meetings in 1990.

23. A total of 27 briefings on the work of the Organization were given to special-interest groups visiting Headquarters, while nearly 1,000 requests for information material were granted.

24. To focus on the aims and achievements of the Industrial Development Decade for Africa, an in-house publicity programme was organized for the first African Industrialization Day (20 November). Two

extensive missions to Africa were undertaken to arouse public awareness and a poster was produced for the event. Two issues of the magazine Industry Africa were published in English and French.

25. Reflecting the thematic perspective, four video features, Biotechnology: Promise for The Future, Women as Colleagues, CAMARTEC Improves Rural Living (Centre for Agricultural Mechanization and Rural Technology) and Bridges for Development, were produced.

26. While continuing to serve the United Nations bodies at the Vienna International Centre (VIC) as well as UNIDO, the audio-visual unit met requests for more than 170 video services, produced 22 radio programmes and took 2,800 photographs. Thirteen major photo exhibitions were mounted in the Vienna International Centre and at the Austria Center.

27. Two display panels were set up at Headquarters as showcases for current public information material. The aim was to publicize the wide range of UNIDO activities as well as the importance of easily-accessible information to promote a better understanding of the Organization's work.

28. An international photo contest was organized to encourage those associated with UNIDO in the field and at Headquarters to help alleviate the dearth of professional-quality photographs of UNIDO-related projects available in the Section's photo library. Although a number of prizes were contributed by firms doing business with the Organization, they failed to attract enough entries of sufficient calibre. Consequently, the contest was postponed until 1991.

#### NEW YORK LIAISON

29. The New York Liaison Office continued to serve as the main link between UNIDO and United Nations Headquarters and as the focal point for industrial development inquiries concerning UNIDO from North and South America. Within the framework of the forty-fifth session of the General Assembly, the Office provided representation and services on subjects of interest to UNIDO, including: the repayment of the United Nations loan to UNIDO; conference and common services at Vienna; preparation for the Second Industrial Development Decade for Africa; report of the Economic and Social Council; international development strategy for the fourth United Nations development decade (1991-2000); development and International Economic Co-operation; United Nations Conference on Environment and Development; operational activities for development; development of the energy resources of developing countries; external debt crisis and development; international co-operation for the eradication of poverty; review and appraisal of the implementation of the Substantial New

Programme of Action for the 1980s for the Least Developed Countries; transfer of technology; international co-operation for industrial development; United Nations common system and the United Nations pension system.

30. As in the previous year, the Office also provided representation at, and reporting on, some 150 intergovernmental and inter-agency meetings that took place in New York or elsewhere in the Western hemisphere, e.g.: the Ad Hoc Committee of the Whole for the Preparation of the International Development Strategy for the Fourth United Nations Development Decade; Preparatory Committee of the Whole for the Special Session of the General Assembly Devoted to International Economic Co-operation, in Particular to the Revitalization of Economic Growth and Development of the Developing Countries; Preparatory Committee for the United Nations Conference on Environment and Development; Committee for Development Planning; Committee for Programme and Co-ordination; meeting of Governmental Experts of Island Developing Countries and Donor Countries and Organizations; Ad Hoc Group Consultations on the role of UNDP in the 1990s; Review of the Committee of the Whole and its Working Group of UNDP Governing Council; Organizational meeting and special session of UNDP Governing Council; Open-ended Consultations on Support Costs; ACC Consultative Committee on Substantive Questions (Operational Activities) (CCSQ(OPS)); Organizational Committee of ACC; joint meeting of CPC/ACC; and United Nations Pledging Conference for Development Activities. Special attention continued to be given to the activities of CCSQ(OPS) because of the major involvement of UNIDO in the Task Force on Support Costs, and to consultations with other executing agencies on the future role of UNDP.

31. The Office continued to participate actively in the efforts of UNIDO to strengthen its relationship with UNDP which, since 1986, has resulted in a significant increase in the number of approved projects. It also assisted in the preparation of the agreement on the UCD programme. It continued to provide assistance to Headquarters in the development, approval and implementation of technical co-operation projects, including recruitment and briefing of experts, placement of fellowship holders, procurement of equipment and organization of study tours.

32. During 1990 the Liaison Office redefined its outreach programme to Member States in North and South America. The Office participated in the UCD meeting in Bolivia in August and briefed them on the activities of the Office and the services available to them. Representatives of the Central American States approached the Office for assistance and, together with a briefing, appropriate support was arranged in co-operation with Headquarters. A major part of the programme for 1990 was

establishing and strengthening relations within the United States that are expected to lead to joint activities during 1991. Such work included contacts made or re-established with: the Departments of State and Commerce, the United States Small Business Administration, the United States Trade and Development Program, the United States Congress, as well as decision makers in over 30 states (emphasis was placed on Wisconsin and Florida), and exploratory work was undertaken with the cities of Atlanta and Pittsburgh. Initial contacts were made in the business community with trade associations, companies and in the academic community with Boston University and the University of California. The Office also participated in missions to two institutions - the World Bank and the Inter-American Development Bank, and to two countries - Bolivia and Hungary. These contacts resulted in concrete expressions of interest to work closely with UNIDO and generated a better understanding of UNIDO and its programmes and activities.

33. In keeping with the UNIDO approach to strengthen its relationship with non-governmental organizations (NGOs), the Office organized, at United Nations Headquarters, a ceremony to witness the signing of an agreement between UNIDO and the Armenian General Benevolent Union and the Government of the Soviet Union for the building and installation in the Armenian Soviet Socialist Republic of a cold storage and meat-processing plant. The Office also expanded its contact with the Non-governmental Organizations Unit of the Department of International Economic and Social Affairs at the United Nations and discussed areas of co-operation, in particular programmes related to sustainable industrial development.

34. Among its activities to increase the awareness of the international academic community to the role of UNIDO as a specialized agency, training programmes were organized for 10 graduate students from North American universities and other countries. The programmes dealt with the subjects of integration of women in industrial development, environment and industrialization, investment promotion, assistance to the least developed countries, the Industrial Development Decade for Africa and the System of Consultations.

35. The Office continued to maintain the extensive collection of documentation and information on UNIDO used by Permanent Missions to the United Nations in New York, industries, research organizations, government agencies, technical experts, academic institutions and libraries. Over 4,000 inquiries were processed during 1990. A significant increase in the number of queries was received from the private sector on the possibilities of co-operation with UNIDO and joint ventures with developing countries.

36. A co-ordinated working relationship with the Geneva Liaison Office was

developed that proved particularly useful in monitoring United Nations activities as well as in keeping missions in both cities informed of UNIDO activities. An example of this was the case of briefing given to the Central American States in New York (see para. 32 above) which was followed by a similar briefing in Geneva for the Central American missions, many of which are not represented in Vienna.

## GENEVA LIAISON

37. The Geneva Liaison Office kept abreast of the policies and programmes of the Geneva-based specialized agencies and departments in order to provide an all-service programme support to UNIDO Headquarters. It identified activities calling for a multidisciplinary approach and promoted initiatives relevant to inter-agency co-operation. Agreement was reached with the International Labour Organisation (ILO) to increase the involvement of UNIDO in its industrial committee meetings, for example, the meetings dealing with iron and steel, leather and footwear. A programme was developed with the World Health Organization (WHO) in the field of human resource development and training for the maintenance of bio-medical equipment. Another programme is being prepared with the International Telecommunication Union (ITU) for the development of production capacities for small telecommunications equipment and spare parts, and a third programme with the United Nations Conference on Environment and Development and the Economic Commission for Europe (ECE) in the field of environment and energy.

38. The Liaison Office represented UNIDO at some 40 meetings. These included conferences, expert group meetings, working groups and other informal gatherings organized by the United Nations, e.g. UNDP Governing Council, Economic and Social Council, ILO Governing Body, World Health Assembly, Second World Climate Conference, informal meeting of the ACC Organizational Committee, United Nations Institute for Training and Research, the United Nations Conference on Trade and Development Trade and Development Board, and inter-agency working groups on non-governmental organizations and on the International Decade for Natural Disaster Reduction. This required intensive preparatory and follow-up work, such as, undertaking research, preparing position papers and statements, arranging for a feed-before and a feed-back system, compiling information on themes of interest to UNIDO, and ascertaining possibilities for follow-up action.

39. Meetings were held regularly with representatives of Governments accredited to UNIDO from Geneva. An initiative was launched to hold periodic meetings with regional or subregional groups. The Liaison Office was called upon to provide assistance to selected missions on specific

matters especially issues under consideration by the UNIDO policy-making organs. A special effort was made to keep Representatives of Permanent Missions informed of any developments in Vienna, particularly those that could not participate in the sessions of the Industrial Development Board and other policy-related meetings of UNIDO. The Office provided advisory services and support for programme and project development activities. It also provided thematic information on specific programmes, at the request of Permanent Missions, for transmission to their capitals, for instance, on privatization, investment promotion, small- and medium-scale enterprises, human resource development and training.

40. Special attention was given to stepping up relations with non-governmental organizations in UNIDO work, for example, the Geneva Liaison Office of the International Chamber of Commerce.

41. Throughout the year there was a continuous flow of inquiries on UNIDO activities including requests for documentation and reference materials from the Permanent Missions, United Nations agencies and departments, intergovernmental and non-governmental organizations, delegations to meetings sponsored by other United Nations agencies, public and private institutions as well as academic and educational institutions and individuals, including students.

## CHAPTER VII. GENERAL ADMINISTRATION

### STAFFING

1. On 31 December 1990 the staff being administered at UNIDO Headquarters, numbered 1,392 (1989: 1,358). The 1990 figures include staff employed for limited periods under the short-term advisory services (STAS) programme. The experimental programme for the recruitment of urgently required staff <sup>1/</sup> had been established for a limited period of time only and was thus discontinued for 1990.

2. As explained in the 1989 Report, the Personnel Services Division was responsible for the recruitment and administration of UNIDO Country Directors (UCDs) <sup>2/</sup> (totalling 29 at 31 December) as well as regional advisers, field officers and out-posted recruitment officers (totalling 6 at 31 December). The procedures relating to the recruitment and administration of UCDs were reviewed and a performance appraisal system will soon be introduced for them.

3. It proved difficult during the year to meet fully the career development aspirations of qualified staff, owing to the cash-flow problems affecting the Secretariat and the limited number of posts available at higher levels. Intensive efforts were made to avoid the separation of staff members with good records of service and thus minimize the negative effects of such a situation on UNIDO's essential programmes. Despite the atmosphere of uncertainty caused by these problems, the staff maintained the enthusiasm and high morale necessary to carry out the UNIDO work programme. Administrative issues affecting the welfare of the staff were discussed within the framework of joint staff/management advisory bodies.

4. In order to ascertain staffing needs for UNIDO for the period of the medium-term plan, 1992-1997, a pilot scheme was being developed for the first time, with the aim of projecting the requirements in staff, both in actual numbers and in areas of technical or professional specialization.

5. UNIDO attended the 1990 sessions of the United Nations Joint Staff Pension Board at which a number of important recommendations were made to the United Nations General Assembly in particular concerning forthcoming changes in the pension adjustment system and the transitional

measures that could be applied for a specific group of participants in the United Nations Joint Staff Pension Fund in the Professional and higher categories. <sup>3/</sup> The final decisions of the General Assembly are contained in its resolution 45/242.

6. The Secretariat also participated in the comprehensive review of Professional salaries in the United Nations common system which was carried out in 1989 and 1990. Furthermore, in accordance with a methodology approved by the International Civil Service Commission (ICSC), a survey of the best prevailing conditions at Vienna for General Service and Manual Worker staff was launched by the Vienna-based organizations. This survey is expected to be completed in April 1991 for review by ICSC at its 1991 summer session.

7. A comprehensive personnel manual was completed. The manual, which contains all the administrative and information circulars on personnel matters currently in force, was gradually distributed in the form of circulars. The staff regulations and corresponding rules were amended with effect from 1 July 1990, to bring them into conformity with the relevant decisions adopted by the General Assembly at its forty-fourth session.

8. The flexible working hours system, which had hitherto only been applied in certain organizational units, was modified and came into force throughout the Secretariat on 1 April 1990.

9. Recruitment activities have been at approximately the same level as in 1989. As of 31 December 1990 there were 55 vacancies (1989: 50) and 53 vacancy announcements (1989: 53). A total number of 6,044 applications (1989: 6,093) were received.

10. Efforts to expedite the recruitment process were continued. By 31 December 1990, 93 staff members (1989: 57) had been recruited in the Professional category and above, 66 men and 27 women (1989: 46 men and 11 women). Five of the women were General Service staff members who advanced to the Professional category. These figures exclude the STAS appointments of 9 men (0 women) (1989: 30, 27 men and 3 women) and the UCDs who numbered 11 men and 1 woman. There were 70 separations, 57 men and 13 women (1989: 44, 36 men and 8 women); of these, 11 men and 5 women were language staff (1989: 11, 8 men and

<sup>1/</sup> IDB.6/10, chap. VII, para. 2.

<sup>2/</sup> *Ibid.*, para. 3.

<sup>3/</sup> For the report of the United Nations Joint Staff Pension Board, see Official Records of the General Assembly, Forty-fifth session, Supplement No. 9 (A/45/9).

3 women); 4/ In the General Service category 77 staff members were recruited (1989: 106), of whom 12 were language staff (1989: 17). In the Manual Worker category 4 appointments were made (1989: 12). There were 58 separations in the latter two categories (1989: 36).

11. Short-term contracts issued numbered 621 (1989: 686) for conference service staff and 223 (1989: 452) for Secretariat staff. In addition, 178 (1989: 657) contracts were issued for consultants and 88 (1989: 141) for individual contractors.

12. Pursuant to Board decisions IDB.7/Dec.22, IDB.5/Dec.36 and IDB.4/Dec.32, efforts continued to increase the number of women serving in the Professional category. As of 31 December 1990, 518 or 20.6 per cent of the roster candidates for Secretariat job opportunities were women (1989: 631 or 21.5 per cent). Of the total number of applications, 1,078 or 17.8 per cent (1989: 1,227 or 20.1 per cent) were submitted by women. Women at the Professional level in the Secretariat numbered 95 (1989: 81), an increase of 17.3 per cent. Women holding posts subject to geographical distribution totalled 75 (1989: 59), an increase of 27.1 per cent and, for the first time, they occupied 21 per cent of such posts; if all Professional posts are considered, their representation was 20.7 per cent. The number of women at the P-5 level and above was 10 (1989: 10). Of the 34 UCDs, 2 were women (1989: 1).

13. Further efforts were made to update and improve the UNIDO roster and special attention was given to candidates from unrepresented and under-represented, especially developing, countries. As of 31 December 1990, the number of roster candidates was 2,518 (1989: 2,939) and of these 1,343 or 53.3 per cent (1989: 1,347 or 46 per cent) were candidates from developing countries.

14. Language training was provided in the six official languages of the United Nations and in German to staff of the Vienna-based organizations and the missions accredited to them. A total of 73 classes were organized in 1990, attended by 904 persons in the spring semester and 902 persons in the autumn semester. In addition, five post-proficiency classes were held in English and French, two workshops on French grammar, two on office communication skills in French and two language maintenance workshops, each in Russian and Spanish. The Vienna-based organizations shared the cost of the language training: the UNIDO share was approximately 43 per cent for the spring semester and 37 per cent for the autumn semester. Language proficiency examinations

were administered for 249 candidates. During the year, 45 university graduates were accepted for the UNIDO Ad Hoc Internship Programme, which gave them the opportunity of obtaining practical experience or doing research on items relevant to the work of the Organization.

15. Advice, information and administrative services were provided on pensions, health and life insurance, compensation claims and staff welfare, to a larger number of participants and staff and with an increasing number of administrative actions. Efforts to automate work processes were continued and a link to the computer system operated by the Secretariat of the United Nations Joint Staff Pension Fund was established enabling faster and more accurate estimates of retirement benefits. This improvement was important in view of the numerous inquiries received in connection with the expiration on 31 December 1990 of the interim measures in the pension system and the proposed transitional measures for local currency pensions, which will affect approximately 170 UNIDO participants. The international bidding process for the group medical insurance policy was completed and the newly negotiated contractual arrangements were to take effect on 1 January 1991.

16. Table 1 below gives the composition of the staff of the UNIDO Secretariat as at 31 December 1990, according to category and sex, and with comparable figures for 1989. In addition, tables 2 and 3 provide details of the distribution by gender since 1988.

(Subprogramme N.2)

## HUMAN RESOURCE PLANNING

17. The systematic approach for staff development that began in 1988 continued to be applied. As reported in 1989, that approach was expeditious in supporting the organizational changes taking place in UNIDO, especially for training in the areas of upgrading technical skills, management development and managerial assistance.

18. Although there was a slight improvement, budget limitations were still a constraint - the training budget in the 1990-1991 biennium represented 0.4 per cent (0.2 per cent in the previous biennium) of staff costs compared to 2 to 5 per cent invested in training by other industries and organizations, including some United Nations agencies. Despite this and training staff limitations, the staff development programme continued to be improved. As in 1989, emphasis was placed on computer skills training, 5/ and it was

4/ Figures for 1990 exclude 11 STAS separations (11 men) and 5 experimental programme separations (5 men).

5/ IDB.6/10, chap. VII, para. 17.

Table 1  
Composition of the UNIDO Secretariat

Category	As at 31 December 1989 a/		As at 31 December 1990 b/	
	Male	Female	Male	Female
P-5 and above	131)	10)	138)	10)
P-1 to P-4	230)361	71)81	225)363	85)95
General Service	183	609	192	623
Manual Workers	114	3	108	4
Language teachers	2	5	2	5
Subtotal	660	698	665	727
<b>TOTAL</b>	1,358		1,392	

a/ Figures include 10 interregional and special technical advisers attached to UNIDO Headquarters but not short-term staff (with the exception of staff employed under the STAS and experimental programmes mentioned in para. 1 above) or UCDs (with the exception of 7 staff members temporarily serving in the latter capacity).

b/ Figures include 8 interregional and special technical advisers attached to UNIDO Headquarters but not short-term staff (with the exception of staff employed under the STAS programme mentioned in para. 1 above) or UCDs (with the exception of 10 staff members temporarily serving in the latter capacity).

Table 2 (a)  
Professional staff in the UNIDO Secretariat, December 1988-1990

Grade	MALE			FEMALE			TOTAL		
	1988	1989	1990	1988	1989	1990	1988	1989	1990
DDG	5	5	5				5	5	5
D-2	4	3	5			1	4	3	6
D-1	30	29	28	2	2	1	32	31	29
P-5	85	94	100	3	8	8	88	102	108
P-4	127	127	129	24	24	34	151	151	163
P-3	76	80	68	35	34	31	111	114	99
P-2/1	18	23	28	14	13	20	32	36	48
<b>TOTAL</b>	345	361	363	78	81	95	423	442	458
	81.6%	81.7%	79.3%	18.4%	18.3%	20.7%	100%	100%	100%

Table 2 (b)  
Percentage of Professional staff in the UNIDO Secretariat, December 1988-1990  
(within each grade)

Grade	MALE			FEMALE		
	1988 %	1989 %	1990 %	1988 %	1989 %	1990 %
DDG	100	100	100			
D-2	100	100	83			17
D-1	94	94	97	6	6	3
P-5	97	92	93	3	8	7
P-4	84	84	79	16	16	21
P-3	68	70	69	32	30	31
P-2/1	56	64	58	44	36	42



Table 3 (a)

Professional staff subject to geographical  
distribution in the UNIDO Secretariat,  
December 1988-1990

Grade	MALE			FEMALE			TOTAL		
	1988	1989	1990	1988	1989	1990	1988	1989	1990
DDG	5	5	5				5	5	5
D-2	4	3	5			1	4	3	6
D-1	28	26	25	2	2	1	30	28	26
P-5	72	77	83	2	6	7	74	83	90
P-4	100	100	105	18	19	28	118	119	133
P-3	57	52	48	25	24	23	82	76	71
P-2/1	9	10	12	8	8	15	17	18	27
TOTAL	275	273	283	55	59	75	330	332	358
	83.3%	82.2%	79.0%	16.7%	17.8%	21.0%	100%	100%	100%

Table 3 (b)

Percentage of Professional staff subject to geographical  
distribution in the UNIDO Secretariat,  
December 1988-1990  
(within each grade)

Grade	MALE			FEMALE		
	1988 %	1989 %	1990 %	1988 %	1989 %	1990 %
DDG	100	100	100			
D-2	100	100	83			17
D-1	93	93	96	7	7	4
P-5	97	93	92	3	7	8
P-4	85	84	79	15	16	21
P-3	70	68	68	30	32	32
P-2/1	53	56	44	47	44	56

possible to deliver 82 courses in various activities related to office automation for a total of 638 Professional and General Service staff (24 per cent more courses than in 1989). Importance continued to be attached to improving management practices in the Organization. A total of 134 middle managers were trained in 10 workshops on interpersonal/intercultural skills development, negotiation skills development as well as goal setting and objective writing. A managerial assistance programme for General Service staff covered modules on interpersonal and intercultural skills development and on the drafting of concise English letters and memoranda; a total of 55 General Service staff members were trained in four courses. In the area of general knowledge upgrading, two seminars were held on staff

development-training strategies and trends and the art of negotiating. All these efforts resulted in the major achievement of a total of 11,000 trainee hours.

19. As in 1989, the emphasis in external training was placed on upgrading technical skills. During the year a total of 22 staff members participated in individual programmes outside UNIDO - a lower figure than in 1989 (50) owing to the cash-flow crisis of UNIDO.

20. A total of 288 job analyses and desk audits resulted in the determination of post levels in the Professional and General Service categories.

(Subprogramme N.5)

## IN-HOUSE STAFF TRAINING, 1990 (Number of staff trained)

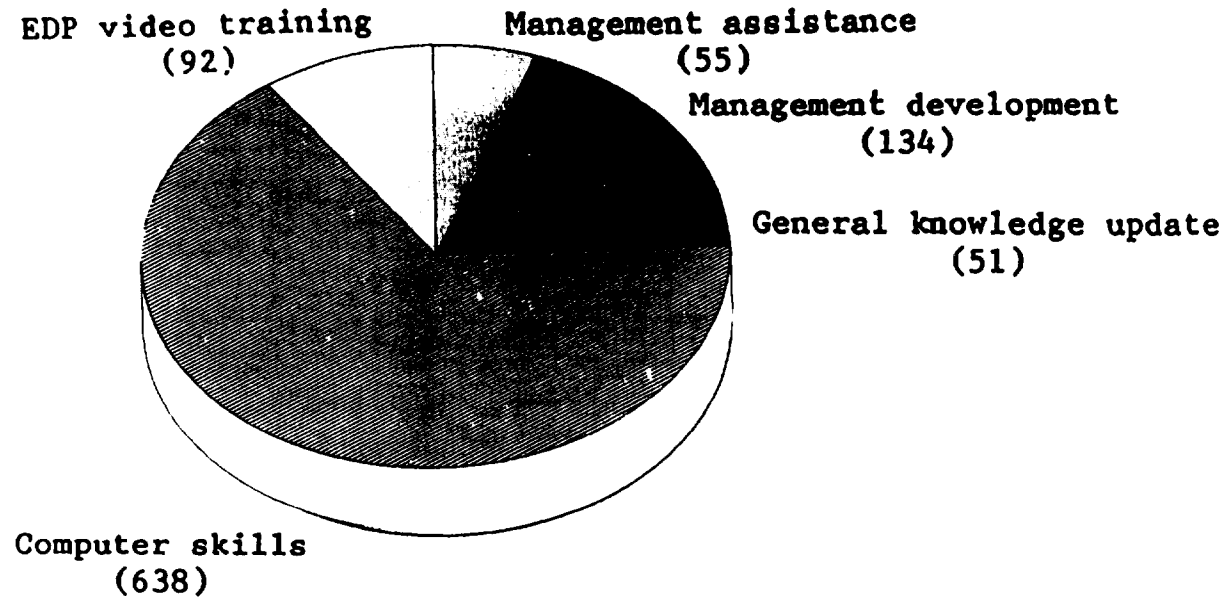

## PROJECT PERSONNEL RECRUITMENT AND ADMINISTRATION

21. The reporting period was the first full year of operation of the Project Personnel Recruitment and Administration Service, created on 1 September 1989. 6/ Despite less than optimal conditions including the relatively slow pace of computerization and tight staffing and financial resources, it was possible to deliver the output required for the greatly increased flow of technical co-operation from UNIDO. Continued efforts to rationalize and simplify recruitment and administration procedures contributed positively towards maintaining the necessary level of services. Examples are the more frequent use of lump-sum arrangements for special service agreements and more rapid communications through use of computerized telex facilities and telefax machines.

22. An upswing in project personnel services was observed, with the number of experts appointed reaching 2,490 or 16.8 per cent more than the 1989 figure of 2,131. This comprised the following categories of project personnel: (a) a total of 263 or 10.56 per cent as international experts appointed under the 200 Series of the Staff Rules (1989: 397), including 40 associate experts financed by 13 European Member States and 73 experts appointed under reimbursable loan agreements for the staffing of mostly large-scale self-financed trust fund projects in Egypt, Libyan Arab Jamahiriya, Nigeria and Yemen; (b) a total of 1,811 or 72.7 per cent international experts on mission (i.e. consultants) employed under special service agreements for periods normally not exceeding six months (1989: 1,446 or 67.9 per cent); and (c) a total of 416 or 16.7 per cent national professional project personnel engaged under service agreements for work in their own countries (1989: 288 or 13.5 per cent). The recruitment of 103 local General Service support staff members (e.g. secretaries and drivers) was also processed for UNIDO field projects (1989: 125). In line with efforts for increased participation of women in industrial development projects, 159 or 6.4 per cent of all recruited experts were women (1989: 111 or 5.2 per cent).

23. Experts' services resulting from appointments and extensions of appointments amounted to 10,997.6 work-months (1989: 9,470.4 work-months) with a monetary value of \$68.83 million or 43.14 per cent of the total implementation value (1989: \$54.35 million or 40.6 per cent). This represents an increase of 16.1 per cent in terms of work-months, and of 26.65 per cent in financial terms, thus confirming the trend observed in the previous report that the financial

expenditure for experts grows faster than the number of work-months actually rendered. 7/ Factors contributing to the higher costs of experts were: the increased costs of highly qualified consultants, both international and national, salary increases for the group of experts benefiting from the United Nations system-wide revision of salaries and allowances, increased travel costs and the effects of the United States dollar exchange-rate fluctuations. The continued prevalence of short-term missions (with an average of 2.7 months in 1990 compared to 2.74 months in 1989) involves higher costs per work-month with regard to travel, recruitment and administration expenses.

24. As compared to the output foreseen in the programme and budgets for the biennium 1990-1991, and using as a base the median of the anticipated range of output (J.3.3.01), the results for the first year of the biennium, namely 2,490 appointments and 897 extensions (representing 10,997.6 work-months and a financial value of \$68.83 million) constitute 56.39 per cent of the forecast in terms of work-months, 68.8 per cent in terms of dollar value, 58.58 per cent in terms of appointments and 39.86 per cent of the extensions. It can therefore be safely assumed that the actual output in 1990 complies with the targets, except for a slightly lower number of extensions compensated for by a higher number of appointments.

25. Efforts were made to further increase the share of developing countries in project personnel recruitment (see chap. IV, para. 22). At the same time, attention was given to offering recipient developing countries the greatest possible choice of qualified project personnel from a wide selection of countries. As shown in table 1 of appendix D, project personnel from 111 countries were recruited. Table 4 below shows that nationals of developing countries constituted 35.8 per cent of all experts appointed, including national experts.

26. The UNIDO roster of candidates continues to be one of the most important sources of recruitment. It contains more than 13,000 individuals from 111 countries. Within the limits set by staff resources and electronic data-processing support available, work continued in improving the quality of the roster in terms of professional composition, availability of candidates and improved roster outputs for evaluation and selection purposes. A total of 1,317 obsolete candidatures were deleted and 1,426 new candidatures, better suited to the anticipated needs of projects, were added to the roster.

27. UNIDO continued to share the costs of the United Nations Technical Assistance

6/ IDB.6/10, chap. VII, para. 20.

7/ *Ibid.*, para. 22.

Recruitment and Fellowships Office in Geneva by financing two interviewing officers and General Service support staff. The officers undertake missions to European and some North African countries when candidates are identified and interviewed for the United Nations and UNIDO without incurring extra travel costs for UNIDO. In 1990 some 347 candidates were interviewed for the UNIDO roster and individual project posts. A UNIDO Regional Recruitment Officer continues to work in the United Nations Development Programme office at Cairo, Egypt, the costs of whom are co-shared with the United Nations Department of Technical Co-operation for Development and the United Nations Development Programme (UNDP). The Regional Officer not only conducted interviews with numerous candidates from Egypt and other African countries but also assisted those countries in setting up national recruitment services.

28. Concerning the administration of all project personnel and locally recruited project support staff (e.g. secretaries, drivers), in 1990 those services covered the contracts of 2,733 international experts (1989: 2,449), 555 national experts (1989: 369) and 328 local support staff members (1989: 343). The services include briefing and counselling on entitlements and benefits and the related correspondence.

29. Following a comprehensive review of the conditions of service of the staff in the Professional and higher categories and in accordance with General Assembly resolution 44/198, UNIDO implemented, effective 1 July 1990, a package of measures containing improved salaries and allowances for Professional project personnel with regular appointments. Revised or new entitlements such as mobility and hardship allowances and a new form of assignment grants were instituted in an effort to enhance the terms of service in the field. To ensure a fair transition to the new system without loss of entitlements accrued under the previous system, transitional measures were developed and greater flexibility was exercised in the day-to-day administration of project personnel. Consequently, an additional workload was absorbed during the transition period.

30. Special efforts were made to resolve, within the framework of United Nations common system rules and regulations, a number of problems arising in certain duty stations such as housing shortages and increased security risks. Among others, *ad hoc* arrangements were made to guarantee fair compensation for installation costs or meal allowances approved in duty stations where conditions required such action.

(Subprogramme J.3.3)

Table 4

Distribution of experts by regional groups of countries  
(1 January to 31 December 1990)

	Number of experts					
	UNIDO roster <u>a/</u>	Percentage of roster <u>a/</u>	Submitted to Government	Selected by Government <u>b/</u>	Appointed <u>c/</u>	Percentage of appointments
Developing countries <u>d/</u>	4,281	33	554	1,110	891	36
List B countries <u>e/</u>	6,882	53	1,032	1,641	1,277	51
List D countries <u>f/</u>	<u>1,844</u>	<u>14</u>	<u>348</u>	<u>511</u>	<u>322</u>	<u>13</u>
	13,007	100	1,934	3,262	2,490	100

a/ As of 31 December 1990, excluding roster candidates for Secretariat posts only (2,547).

b/ Including government nominees and national professional personnel.

c/ Including appointment of 416 national professional experts.

d/ States in lists A and C of Annex I to the UNIDO Constitution plus Albania, Cyprus, Greece, Malta, Portugal, Romania and Turkey.

e/ States in list B of Annex I to the UNIDO Constitution, excluding Cyprus, Greece, Malta, Portugal and Turkey. Included are roster candidates from the former German Democratic Republic.

f/ States in list D of Annex I to the UNIDO Constitution, excluding Albania and Romania. Excluded are roster candidates from the former German Democratic Republic.

## GENERAL SERVICES

31. The total value of project equipment and supplies delivered for technical co-operation projects was \$43.0 million (1989: \$40.1 million). That amount represented 2,966 individual orders (1989: 3,315) of which 852 or 28.7 per cent (1989: 741 or 22 per cent) were placed with manufacturers and vendors from developing countries to a value of \$8.9 million (20.7 per cent), and 251 (8.5 per cent) were placed with manufacturers and vendors from the so-called major under-utilized donor countries to a value of \$3.27 million (7.6 per cent).

32. The demand for the services of consulting firms in the implementation of technical co-operation programmes has increased steadily; in 1990, the demand was 75 per cent higher than in 1988. New contracts amounted to 204 (1989: 185) which were awarded to companies from more than 50 countries for a total value of \$19.2 million (1989: \$19.2 million). Special attention was given to companies and consulting firms from developing countries and major under-utilized donor countries. Each list of invitees included from 1 to 4 companies from these countries. As a result of these initiatives, 75 contracts (36.8 per cent) at a total value of \$4.16 million (21.6 per cent) were awarded to enterprises from developing countries, while 9 contracts (4.4 per cent) amounting to \$5.12 million (26.6 per cent) were signed with companies in under-utilized major donor countries. Simultaneously, efforts were made to expand and update the information on companies from developing and under-utilized major donor countries in the roster of industrial consulting firms and organizations which, by the end of 1990, included nearly 3,000 enterprises. A new electronic data processing application (Contracts Management and Information System) was developed and tested that allows the control of all phases of implementation of up to 1,000 contracts.

33. In addition to the work of continuous maintenance, repair and servicing, buildings management activities included implementation of a digital United Nations communications circuit that allows for simultaneous voice and data transmissions between New York and Vienna; partial implementation, within available funding, of the Vienna International Centre (VIC) programme for the physically handicapped; finalization of work on the UNIDO data network and relocation of local terminal controllers from the International Atomic Energy Agency (IAEA) to the UNIDO mainframe; introduction of a computerized time and attendance system for Buildings Management Section staff; renovation of the VIC kitchen; implementation of an advanced telephone system in UNIDO to allow better use of available extensions; and a buildings improvement programme to eliminate asbestos fibres. The first phase

was implemented of a computer-aided design programme for the VIC architectural plans to produce (in the second phase) information which will facilitate the planning of building modifications and staff relocations. The cash-flow problem besetting the Organization resulted in partial deferment to 1991 of the maintenance of those VIC systems that is usually carried out with the use of overtime funds.

34. The computerization was completed of the inventory records for more than 730 technical co-operation projects. That programme was made fully operational with the introduction of approximately 7,000 inputs and amendments. In addition, transfer of title documents were finalized for equipment with a total value of \$15.9 million in the case of some 112 field projects. As of January 1990, UNIDO assumed responsibility for the inventory, maintenance and control of property for 39 UNIDO Country Directors' offices. An effective computerized system for the inventory of small items was established in the VIC catering services and the first physical inventory using a new bar code reader system was successfully completed in September. The Property Survey Board was presented with more than 90 case reports. Following approval of the Board for the write-off of more than 400 old and worn out items, the practice of offering surplus and/or unserviceable items for sale to the staff at the VIC was continued.

35. Full registry and archives services were maintained for UNIDO, the Centre for Social Development and Humanitarian Affairs and the Personnel Service of the United Nations Office at Vienna (UNOV) while archive reference services were also provided to the United Nations Communications Unit and Division of Narcotic Drugs. Although the volume of communications received for UNIDO increased considerably owing to the higher technical co-operation delivery and the expansion of certain activities, a centralized system enabled specialized information to reach the respective users. In October, the storage of computer tapes was introduced. UNIDO accessions amounted to 382.5 linear metres (1989: 404.5), whilst 132.5 linear metres (1989: 373) of UNIDO holdings were disposed of. The United Nations accessions amounted to 14 linear metres (1989: 29.5), the disposals to 26 linear metres (1989: 26.5).

36. Over 14,000 travel authorizations were issued, representing an air ticket value of approximately \$13.6 million (out of which 1,305 ticket authorizations (\$2 million) were sent to UNDP offices). In that connection, 2,000 visas were obtained and 1,347 letters of assistance for travel of staff members were issued. A total of 1,945 shipments of equipment and documents of the Organization were arranged for UNIDO and UNOV, and 108 insurance claims were filed with the insurance broker, of which 82 were settled.

(Subprogramme N.3)

### A. Number of contracts awarded in 1989

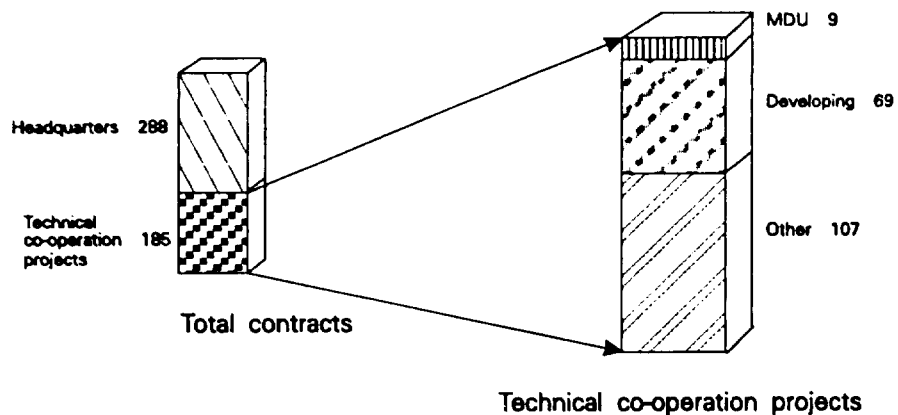

### B. Number of contracts awarded in 1990

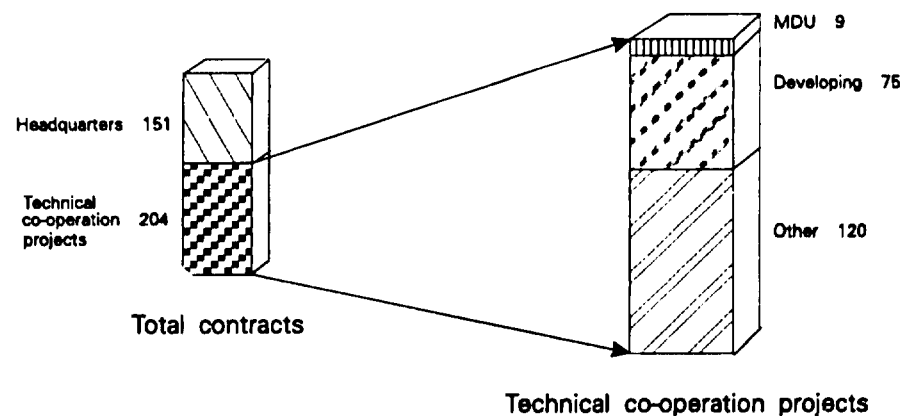

### C. Value of contracts awarded in 1989

(In millions of US\$)

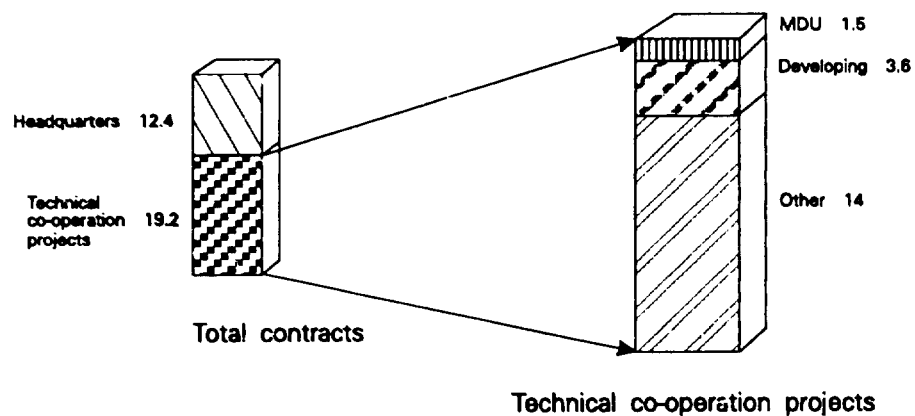

### D. Value of contracts awarded in 1990

(In millions of US\$)

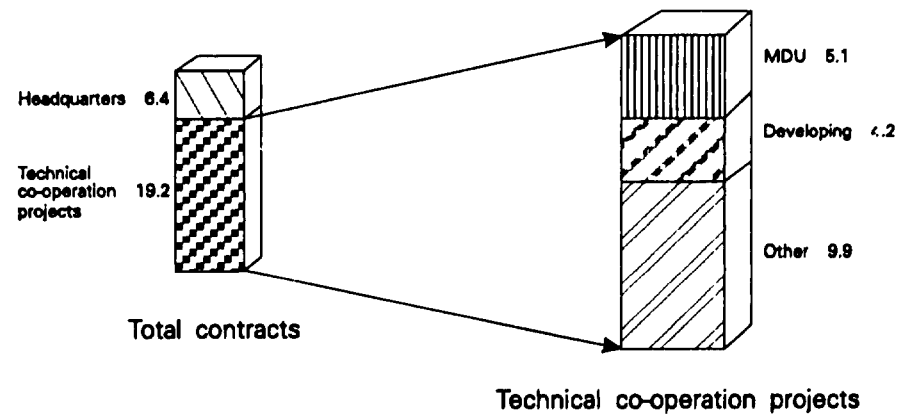

## Number and value of contracts awarded, 1989 - 1990

### A. Number of purchase orders placed in 1989

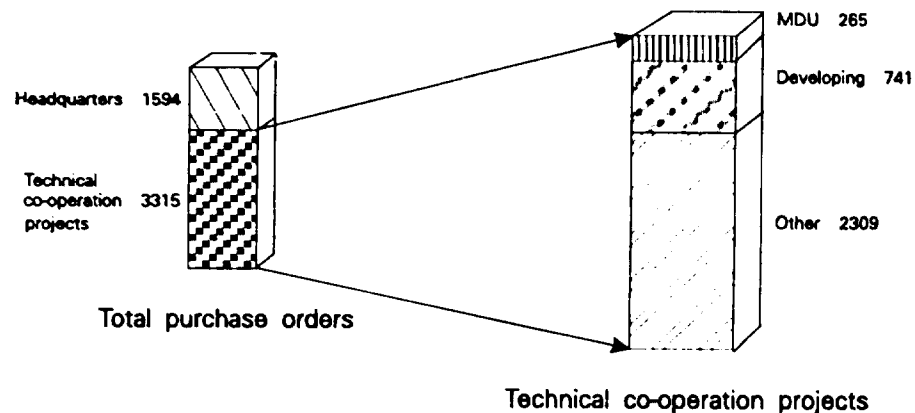

### B. Number of purchase orders placed in 1990

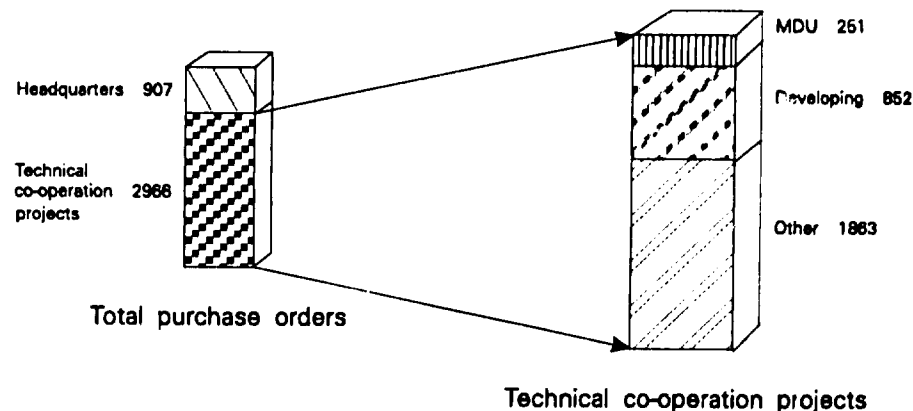

### C. Value of purchase orders placed in 1989

(In millions of US\$)

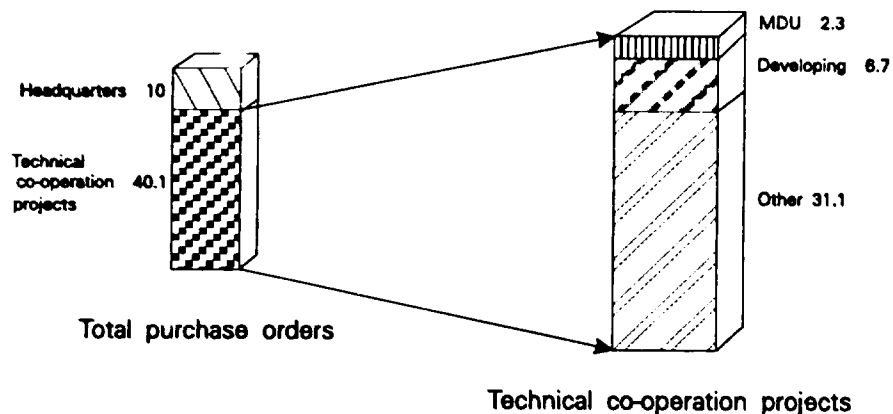

### D. Value of purchase orders placed in 1990

(In millions of US\$)

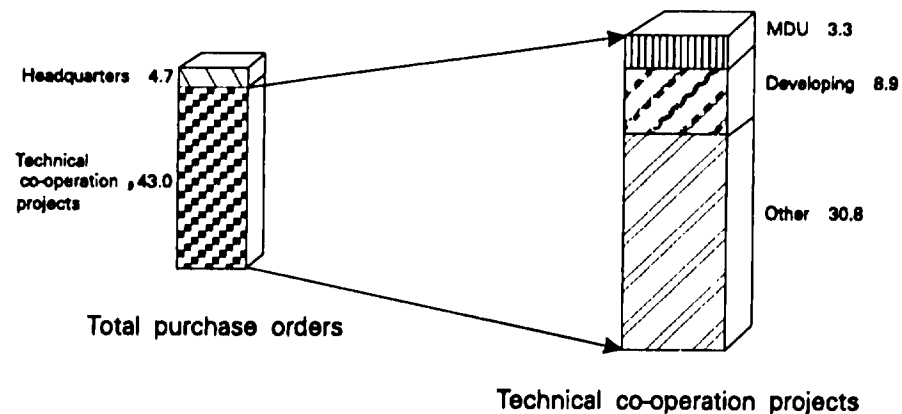

## Number and value of purchase orders placed, 1989 - 1990

MDU = Major donor underutilized countries

## CONFERENCE SERVICES

37. Conference services continued to be rendered on a joint basis under the same administrative and financial arrangements in force since 1986 (IDB.3/10, chap. VII, paras. 30-31). As in the past, the UNIDO Languages and Documentation Division provided a full range of translation and publishing services to both UNIDO and the United Nations entities in Vienna, while the Meetings Planning and Interpretation Service operated by the United Nations continued to service all United Nations meetings in Vienna as well as all UNIDO meetings held in Vienna and elsewhere.

38. Tables 5 to 8 below provide information on translation and interpretation services and on the number of meetings serviced for UNIDO and the United Nations.

39. The Editorial Control and Publications Section continued to provide editorial, typesetting, reproduction, distribution and other related services to UNIDO and UNOV. Table 8 shows the distribution of the workload between the two organizations during the year. One of the functions of the Section is to provide efficient, cost-effective photocopying services throughout UNIDO and UNOV. In 1988, a new system was introduced <sup>g/</sup> which, since then, has reduced overall copying costs by AS 3 million.

40. In 1990, the Languages and Documentation Division concentrated on further improvement of management with

emphasis on monitoring the work process, introducing system analysis techniques and building a reliable and diversified statistical data base. Streamlining the temporary assistance recruitment pattern was and will remain a priority area in order to economize, a measure related to the work undertaken in the improvement of forecasting the volume and the timing of the translations and editorial work required by UNIDO and UNOV.

41. In office automation, the main development was the start of trials to convert the Chinese Typing Pool into a word-processing unit on an experimental basis. Conversion of the other five language pools is almost completed.

42. The Documents Control Unit controls all submissions and processes all jobs requiring translation, editing, artwork, presentation, typesetting and printing from UNIDO and UNOV (in 1990, 14,719 jobs were processed of which 48 per cent were for UNIDO and 52 per cent for UNOV). The computer-aided documents control system, one of the largest data bases in UNIDO, is being expanded to include new users in the Division and, eventually, all substantive units of UNIDO and UNOV, using internal programming resources. The purpose of the system is to generate workload statistics and is the basis for cost sharing between UNIDO and UNOV.

43. As regards staffing of the joint conference services, recruitment was under way to fill nine vacant posts for the translation services and one editor post. Out of 20 posts in the Meetings Planning and Interpretation Service, 18 were filled at the end of the year.

<sup>g/</sup> IDB.6/10, chap. VII, para. 44.

Table 5

Translation services provided by the UNIDO Languages and Documentation Division during 1989 and 1990  
(in thousands of words translated)

Organization served	1989	1990
UNIDO	8,390 <sup>a/</sup>	6,943 <sup>b/</sup>
United Nations	12,054	12,571

<sup>a/</sup> Includes 3,899,400 words for the policy-making organs of UNIDO.

<sup>b/</sup> Includes 3,779,800 words for the policy-making organs of UNIDO.



Table 6

Interpretation services provided by the Meetings Planning and  
Interpretation Service (UNOV) in 1989 and 1990  
(in interpreter-days)

Organization served	1989	1990
UNIDO	1,481 <u>a/</u>	663
United Nations	2,050	3,463 <u>b/</u>

a/ Includes 181 interpreter-days for the fifth session of the Programme and Budget Committee, 303 interpreter-days for the fifth session and the third special session of the Industrial Development Board, and 324 interpreter-days for the third session of the General Conference.

b/ Includes 518 interpreter-days of loans to other organizations.

Table 7

Conferences and meetings with and without interpretation serviced  
by Meetings Planning and Interpretation Service in 1990  
(1 January - 31 December 1990)

Conferences/ meetings held	Number of half-day meetings					
	UNIDO			United Nations		
	With interpre- tation	Without interpre- tation	Total	With interpre- tation	Without interpre- tation	Total
In Vienna	97	528	625	249	507	756
Elsewhere	<u>82</u>	<u>368</u>	<u>450</u>	<u>76</u>	<u>6</u>	<u>82</u>
Total	179	896	1,075 <u>a/</u>	325 <u>b/</u>	513	838

a/ UNIDO meetings include 36 meetings with interpretation, and 26 meetings without interpretation held in connection with the spring session of the Administrative Committee on Co-ordination, the sixth and seventh sessions of the Industrial Development Board, the sixth session of the Programme and Budget Committee and the meeting of UNOP and the Consultative Committee on Administrative Questions (Finance and Budgetary Questions)/Consultative Committee on Substantive Questions (Operational Activities) (CCAQ(FB)/CCSQ(OPS)) Joint Working Party upon invitation by UNIDO.

b/ United Nations meetings include 66 meetings with interpretation held in connection with the eighth United Nations Congress on the Prevention of Crime and the Treatment of Offenders, Havana, Cuba, jointly serviced by the Meetings Planning and Interpretation Service, Vienna, and Department of Conference Services from United Nations Headquarters. Interpretation Services were also provided to The World Ministerial Summit to Reduce the Demand for Drugs and to Combat the Cocaine Threat, London, England.

Table 8

Editorial Control and Publications Section:  
distribution of workload in 1990  
 (Figures for 1989 in parentheses)

U N I D O		United Nations	
<u>Editing</u>			
<u>Thousands of words</u>	<u>Per cent of total</u>	<u>Thousands of words</u>	<u>Per cent of total</u>
2,109 (1,835)	58 (43)	1,530 (2,390)	42 (57)
<u>Editorial assistance at meetings</u>			
<u>Days</u>	<u>Per cent of total</u>	<u>Days</u>	<u>Per cent of total</u>
0 (10)	0 (13)	58 (66)	100 (87)
<u>Preparation of camera-ready pages</u>			
<u>Pages</u>	<u>Per cent of total</u>	<u>Pages</u>	<u>Per cent of total</u>
2,565 (3,014)	39 (38)	4,042 (5,022)	61 (62)
<u>Documents and publications distributed: reproduction and distribution services provided at meetings</u>			
<u>Documents and publications distributed</u>	<u>Per cent of total</u>	<u>Documents and publications distributed</u>	<u>Per cent of total</u>
2.4 million (3.8 million)	51 (58)	2.3 million (2.7 million)	49 (42)
<u>Meetings serviced (days)</u>		<u>Meetings serviced (days)</u>	
31 (53)	30 (38)	72 (88)	70 (62)

## CHAPTER VIII. SOURCES OF FUNDS

### A. FINANCING OF TECHNICAL CO-OPERATION ACTIVITIES

1. Technical co-operation for the benefit of the developing countries continued to be the main activity of UNIDO with the value of net approvals of projects amounting to \$162.7 million in 1990 (1989: \$171.5 million).

2. The sources of finance for UNIDO technical co-operation activities were again the indicative planning figures (IPFs) of the United Nations Development Programme (UNDP), the Special Industrial Services (SIS) programme of UNDP, the Industrial Development Fund (IDF), the UNIDO regular programme of technical co-operation (RP) <sup>1/</sup> and the Industrial Development Decade for Africa (IDDA) <sup>2/</sup> both within the regular budget of UNIDO, trust funds and self-financing arrangements with developing countries as well as a number of United Nations funds.

#### UNDP INDICATIVE PLANNING FIGURE AND COST SHARING

3. By the end of 1990, UNIDO's share in the approved country programmes of the fourth UNDP programming cycle (1987-1991) remained the same as in 1989: 145 country programmes had been approved by the Governing Council of UNDP within which UNIDO had been designated executing agency for 593 projects (168 ongoing and 425 new). This represents approximately 12.1 per cent of the total programmed resources, although the allocations for the industry sector had originally been estimated at 11.1 per cent (see appendix E).

(Subprogramme E.2)

4. With the net approvals of \$81.4 million in 1990 (1989: \$78.6 million), total net approvals of the fourth programming cycle (1987-1991) reached \$352.7 million. Similarly, the delivery in 1990 reached \$88.7 million (1989: \$76.8 million) leading to a total expenditure figure of \$306.0 million in the current cycle (see statistical annex, table 2.C).

<sup>1/</sup> Reflected in figures of chap. II and tables of appendix G as "XP".

<sup>2/</sup> Reflected in figures of chap. II and tables of appendix G as "XA".

### SPECIAL INDUSTRIAL SERVICES PROGRAMME

5. The Governing Council of UNDP allocated \$15 million to UNIDO for the fourth programming cycle (1987-1991) of the SIS programme, to be distributed in equal annual instalments of \$3 million throughout the cycle.

6. UNIDO, as in previous years, applied a highly selective policy when approving projects, in line with the criteria set out in the guidelines for the SIS programme. <sup>3/</sup> A high rate of approvals was achieved in 1990, thus bringing the cumulative approvals for the cycle to a total of \$15.7 million. An effort was made to ensure a reasonable geographical distribution, taking into consideration the needs of the least developed countries, for which 17 per cent of the total amount approved was allocated. During the year, 91 new projects were approved amounting to \$5.4 million, out of which \$0.7 million (13 per cent) was approved for the least developed countries. The value of approvals of SIS-financed projects in 1990 by geographical area is shown in table 1 below.

7. The number of requests for SIS projects increased substantially in 1990 as a result of the effective dissemination of information describing the type of services provided under this programme. The potential of the programme to respond to urgent needs in a rapid and non-bureaucratic manner has become increasingly important, in particular in connection with the ever-growing need for rehabilitation of industrial plants, one of the priorities of the UNIDO medium-term plan. Despite this growing demand, UNIDO was unfortunately faced with the need to slow down SIS approvals during the last months of 1990, since the cycle was approaching its end and no decision had been taken by UNDP on the continuation of the programme. Consequently, negotiations began with UNDP to secure funds for the forthcoming cycle, 1992-1996, to assure the continuation of a programme that has proved to be effective in meeting the increasing demand for urgently required assistance. In view of the substantially decreased dollar real value since 1987, efforts were also made to obtain at least a 20 per cent increase in the UNDP allocation for the next cycle.

(Programme element E.4.1.01)

<sup>3/</sup> UNDP/PROG/H of 7 June 1988.

**Table 1**  
**Value of SIS programme**  
**approvals, by area, in 1990**

Geographical area	Value of approvals (in thousands of \$)	Percentage of total value
Africa a/ Latin America and the Caribbean	1,656	30.4
Arab States a/ (African Arab States) b/	1,434 521 (392)	26.3 9.6 (7.2)
Asia and the Pacific	1,311	24.1
Europe	914	16.8
<b>TOTAL</b>	<b>5,444</b>	<b>100.00</b>

a/ Includes African Arab States.

b/ Deducted since included under both "Africa" and "Arab States".

#### TECHNICAL CO-OPERATION - REGULAR BUDGET ALLOCATIONS

##### Regular programme of technical co-operation

8. For the regular programme of technical co-operation - excluding the Industrial Development Decade for Africa (IDDA) - a total of \$5,558,000 was approved by the General Conference for the biennium 1990-1991. The distribution of the regular programme allocation and the corresponding delivery in 1990 are provided in appendix C. In programming the funds, every effort was made to achieve an equitable geographical distribution, while taking especially into consideration the needs of the African and least developed countries. (E.4.1.01)

##### Allocations for the Industrial Development Decade for Africa

9. Under the regular programme of technical co-operation for 1990-1991, the General Conference approved a separate allocation of \$3,846,100 for IDDA to cover activities on the rehabilitation and development of agro- and agro-related industries and other key industries determined through the integrated programming process. (For the allocations and delivery in 1990, see appendix C.) In addition, \$4,766,600 was allocated under the 1990-1991 regular budget to cover the following supplementary activities in support of the Decade: integrated programming and preparatory assistance activities, short-term advisory services, and public information activities.

10. With the aim of ensuring an early implementation of the projects and their possible completion by the end of the 1990-1991 biennium, the allocation for IDDA was fully programmed in 1990, primarily for projects in the field of agro-industries.

(Subprogramme E.2)

#### OPERATIONAL BUDGET

11. As stipulated in financial regulation 3.4(b), the operational budget shall show the expected income and expenditures in respect of voluntary contributions to IDF, such trust funds, reserve and special accounts as have been established by the Director-General and support costs of technical assistance delivery. Information on the activities financed from these sources of income is provided under the respective headings of the present chapter in compliance with Board decision IDB.4/Dec.26(f).

12. In its decision GC.3/Dec.23(f) the General Conference approved estimated expenditure totalling \$35,723,000 (at an exchange rate of US\$1 = AS 12.90) for the purpose of the operational budget for the biennium 1990-1991, to be financed from voluntary contributions and other such income provided for in the financial regulations.

13. There were 318 staff (82 Professionals and 236 General Service) on board, including ad\_hoc posts, in the operational budget in December 1990, compared with 299 staff (72 Professionals and 227 General Service) in December 1989. Expenditure recorded in 1990 amounted to \$19.8 million (at an average exchange rate of US\$1 = AS 11.43) while income from technical co-operation delivery and other income in 1990 amounted to \$21.1 million. Expenditure increase in 1990 was fully met by higher than expected income from technical co-operation delivery and other income.

14. The Board, in its decision IDB.7/Dec.13, decided to submit to the General Conference at its fourth session, for consideration and adoption, proposed amendments to financial regulation 4.1, on budgetary approval. Those amendments relate to: the monitoring of income and expenditure under the operational budget when it becomes clear that actual income will not be sufficient to support expected expenditure levels; obligations and payments in excess of the limitations set by the Conference for the operational budget; and the financing of additional service and support costs related to increased obligations and payments.

15. In accordance with the provisions of paragraph 5(a) of UNDP Governing Council decision 81/40, the Organization submitted to the Governing Council a request for compensation for losses sustained in 1990 in respect of support cost reimbursements

as a result of currency fluctuations. (For more information on the issue of support costs, see paras. 30-38 below).

## INDUSTRIAL DEVELOPMENT FUND

16. Announced pledges to IDf in 1990 amounted to \$29.8 million. The breakdown by segments of the Fund shows that the general-purpose convertible segment amounted to \$1.4 million, while the special-purpose convertible segment was \$24.7 million, and the special-purpose and general-purpose non-convertible segments totalled \$3.7 million. The overall IDf resources in 1990 decreased in comparison to the all-time high reached in 1989 of \$39.3 million. This decrease is due to the change in pledging patterns, based on factors beyond UNIDO's control (see also chap. I, para. 9).

17. Appendix H provides information on firm pledges and receipts, the status of resources and cumulative project approvals as at 31 December 1990. The net value of projects approved amounted to \$30.8 million (1989: \$31.7 million), distributed as follows: general-purpose convertible \$1.9 million (6.2 per cent); special-purpose convertible \$25.6 million (83.1 per cent); special-purpose and general-purpose non-convertible \$3.3 million (10.7 per cent). For new projects approved during the year, a breakdown for each segment by region and programme component is given in appendix H, table 4. The approval rate is indeed exceptionally high considering that the same amount was approved in the preceding year based, however, on larger overall resources available. This high approval figure also proves that quality of projects has improved, thus enabling UNIDO and donors to fully programme pledges in a timely and efficient manner.

18. Programming flexibility continued to be limited owing to scarce resources available under the general convertible pool - the only freely programmable segment of the Fund. UNIDO was nevertheless able to ensure a reasonable geographical distribution of funds. The breakdown provided in appendix H shows that highest priority was awarded to projects of a global and interregional nature (64.2 per cent) having an impact on a large number of countries. The Fund has thus continued to be UNIDO's main financing source for the promotion of global and interregional projects and programmes. Such "horizontal" assistance activities, which have been awarded high priority in the medium-term plan, are better promoted through a multilateral channel. Distribution by region was ensured in an equitable manner: Africa 10.1 per cent, Latin America and the Caribbean 8.7 per cent, Arab States 3.1 per cent, Asia and the Pacific 13.7 per cent, Europe 0.2 per cent. The breakdown by programme component reveals the emphasis on the priority areas - development and transfer of industrial

technology, as well as training and promotional activities, including investment promotion. The channelling of IDf funds to these activities was in line with the medium-term plan 1990-1995 (GC.3/17) and the mandates to promote the development and transfer of technology, human resource development and mobilization of financial resources for industrial development.

19. The general-purpose segment of the Fund continued to be utilized mainly for preparatory assistance projects aimed at attracting larger-scale contributions from special-purpose donors or other sources of financing. Approximately 26.1 per cent of the general convertible pool was used as seed money for programming non-convertible contributions. Virtually the whole non-convertible segment of the Fund was programmed for training activities that took place in the respective donor countries with wide-ranging participation from the developing countries.

20. Some positive developments in the pattern of pledges to IDf should be highlighted. Several donors decided to provide contributions which will enable UNIDO to programme funds with increased speed and flexibility. For the first time, the Government of the Netherlands announced a contribution to the general convertible pool, to the amount of \$657,895; the Government of Italy announced a contribution of \$200,000 to the general convertible pool and the Government of Austria has doubled its contribution to the general convertible pool, which now totals \$155,000. Furthermore, umbrella contributions were provided by the Governments of Norway and Sweden to assist in the development of the environment programme and the Government of Germany approved an umbrella project for that programme's preparatory assistance activities. Such umbrella contributions enable more flexible and efficient programming of funds since final approval authority of the sub-projects is delegated to UNIDO within a financial and substantive framework mutually agreed upon with the individual donors.

21. In order to encourage more donors to follow suit, particular emphasis was placed throughout the year on the application of quality control measures for the selection and development of projects and programmes and on ensuring full transparency of IDf activities. A particular effort was also made to launch large-scale activities within the framework of the special regional programmes of UNIDO.

(Programme element E.4.1.01)

## TRUST FUNDS AND SELF-FINANCING ARRANGEMENTS

22. In 1990, the self-financed and third party-financed trust fund schemes achieved the expected growth and assumed a prominent

position among the different funding sources for UNIDO technical co-operation activities. The total value of project agreements signed under these schemes was \$43.4 million of which \$27.2 million represent projects approved and under implementation (16.7 per cent of UNIDO total approvals), while expenditure on technical co-operation activities rose to \$25.7 million (16.1 per cent of UNIDO total expenditure). The corresponding figures for 1989 were \$41.4 million (24 per cent) for approvals under implementation and \$16.5 million (12 per cent) for project expenditures. The overall growth trend 4/ indicates that through special trust fund mechanisms UNIDO is increasingly requested to provide services to industrial plants (both public and private) in the developing countries, development finance institutions and governmental and non-governmental donor agencies against reimbursement of cost by the beneficiaries of such services. This trend would not be evident if beneficiaries had not realized the capacity of UNIDO to act as an impartial intermediary, free from profit motive and commercial pressures and offering quality services at a reasonable cost. Examples of special trust fund activities that were initiated or implemented during 1990 are given below.

23. Among projects for better utilization of installed industrial capacity and plant performance improvement, those in the cement sector continued to dominate the scene owing to UNIDO's proven track record, which is now widely recognized by the cement industry in the developing countries (E.4.3.01). Under the self-financed trust fund scheme, UNIDO provided 11 cement plants (five in the Libyan Arab Jamahiriya, three in Egypt, two in Nigeria, one in Yemen) with expert teams for process optimization, plant performance improvement and training of local personnel in operational and maintenance methods and procedures. The results were gratifying: production and trained manpower increased all round, resulting in substantial improvements in the companies' financial performance. Negotiations were launched for similar assistance to cement plants in Gabon, Indonesia, the Islamic Republic of Iran and United Arab Emirates, while the problems besetting the cement industry in Angola, Ecuador, Kenya, Morocco, Nicaragua, Somalia and Sudan were studied with a view to formulating assistance programmes. As part of its activities related to human resource development, UNIDO organized four self-paying training programmes and seminars on cement technology in India and Turkey in which 58 technical and managerial persons from several developing countries participated.

24. Two major entries into the petrochemicals sector were made with the signing up of self-financed trust fund

projects for the management and operation of an ammonia plant and a polyvinylchloride (PVC) plant in the Libyan Arab Jamahiriya, and negotiations on the establishment of a plastics technology centre in Nigeria along the lines of the UNIDO-assisted centres in China, India and Pakistan under UNDP financing. Also under the self-financed trust fund scheme, UNIDO provided prompt assistance in project planning and financing to mainly private industrialists and entrepreneurs in the developing countries. UNIDO was instrumental in shaping up the pharmaceutical project in Cameroon 5/ on a sound technical and commercial basis and in securing the necessary foreign equity and loan financing. In addition to the preliminary market study and techno-economic analysis, and negotiations with a foreign technical partner, UNIDO assisted the Cameroonian company by carrying out a bankable feasibility study and helping in negotiations with licensors. The costs of UNIDO services were shared equally by the Cameroonian company, the Swedish technical partner and Swedfund. In another example, UNIDO arranged and supervised, under very favourable terms, the testing of raw materials for a planned cement plant in Nigeria; this assistance will continue throughout the planning phase until plant completion and commissioning. Assistance in technology selection and acquisition was provided to the Saudi Basic Industries Corporation in Saudi Arabia and to a Mexican entrepreneur planning to set up a chemical plant in Venezuela, while in the Libyan Arab Jamahiriya UNIDO helped in the planning and equipment selection for artificial leather production. The Government of the Islamic Republic of Iran expressed its intention to use the services of UNIDO for establishing a pharmaceutical complex and ancillary research and development facilities; a self-financed trust fund project was started for the purpose of carrying out a techno-economic study under UNIDO supervision.

25. An increasing number of consulting and engineering companies in the developing countries recognized the value of the self-financed trust fund scheme for obtaining services from UNIDO at short notice and under favourable terms in order to help their companies grow and acquire a sharper competitive edge. An engineering company in Egypt was assisted by UNIDO for advanced training of its design engineers in the petroleum refining sector and for design, engineering and equipment selection for a coal mining project, while a Gabonese promoter requested UNIDO assistance in establishing a consulting company, which will be the first of its kind in the country. The advantages of procuring industrial raw materials, equipment and machinery through UNIDO were recognized and therefore such activities were included in some projects, e.g., assistance to a

4/ IDB.6/10, chap. VIII, para. 22.

5/ Ibid., para. 24.

textile testing laboratory in Argentina, a mineral beneficiation facility in the Democratic People's Republic of Korea and a steel rolling mill in Peru.

26. There was growing recognition by development finance institutions and similar organizations that UNIDO could provide valuable support in their operations in the industrial sector, particularly in investment project identification, evaluation, implementation and monitoring (E.4.3.02). In addition to investment opportunity studies carried out for the Nigerian Industrial Development Bank, 6/ UNIDO began assisting the New Nigeria Development Company Ltd. with advisory services for pre-investment studies and diagnostic studies for plant rehabilitation under a revolving trust fund deposited in UNIDO by the company. A similar arrangement was concluded with the Islamic Development Bank for pre-investment and rehabilitation studies on industrial projects in which the Bank intended to participate or had participated. This major development in Islamic Development Bank/UNIDO co-operation began with UNIDO investigations on how to improve the performances of a cement mill and a pharmaceutical plant in the United Arab Emirates; several other plants in many Islamic countries were scheduled to be studied. In Cameroon, another revolving trust fund was established by the Société Nationale des Investissements in order to seek UNIDO help in project development and pre-investment work. The first case was a feasibility study for a brick factory in Yaoundé for which help would be provided in technology selection and joint venture negotiation, possibly with a Moroccan partner.

27. Realizing the advantages offered by UNIDO's unique scheme, its ability to tackle a wide range of industrialization problems and its extensive network of contacts in business and industry in the developing as well as industrialized countries, many governmental and non-governmental organizations, including donor agencies, turned to UNIDO for programme and project management services (E.4.3.03). For example, under a trust fund arrangement, the USA-based Armenian General Benevolent Union provided funds for UNIDO to build a 10,000-ton cold store and meat processing and packaging plant in the Armenian Soviet Socialist Republic town of Leninakan. Planned for completion by mid-1991, the new seismic-resistant installation will replace a plant that became obsolete through damage in the 1988 earthquake. The Japan International Development Organization Ltd. (JAIDO), founded by the Federation of Economic Organizations (KEIDANREN) and the Overseas Economic Co-operation Fund to promote direct investment in the developing

countries, made a trust fund contribution to UNIDO to finance selected pre-investment studies, e.g., an agro-industry project in Brazil, an aluminium rolling mill in Poland and a coke production plant in Venezuela. Trust fund contributions from the Engineering Consulting Firms Association of Japan were used to finance a pre-feasibility study in Mexico for the development of supporting industries in the electronics sector, while another third-party-financed project was established in Myanmar to assist the Government in formulating a development plan for the manufacturing sector.

28. Increasing support for the third-party-financed trust fund scheme was received from donor agencies in Denmark, France, Japan, Republic of Korea and the United Kingdom of Great Britain and Northern Ireland. Co-operation with Danish industry through funds provided by the Danish International Development Agency entered a second phase with the identification of work to be undertaken jointly in several African countries, in particular pre-investment studies and diagnostic studies for plant rehabilitation. South-South co-operation projects at the enterprise level were initiated in metallurgical industries with a contribution from China and in the electronics and steel sectors with funds from the Republic of Korea.

29. The annual trust fund contributions received from the Government of Japan since 1987 financed a variety of interesting and innovative activities (predominantly in Africa and small island countries) with strong emphasis on agro-industries, rural development, small-scale industries and integration of women in industrial development. Trust fund contributions were also received from Japan and the United Kingdom (in addition to their usual development aid budgets) for UNIDO assistance to Hungary and Poland in their industrial restructuring and modernization process.

## PROGRAMME SUPPORT COSTS

30. The operational budget is mainly funded from income earned in the delivery of technical co-operation projects. This income is calculated as a fixed percentage (generally 13 per cent) of the value in United States dollars of the technical co-operation projects delivered and is intended to cover the support costs of the Organization in implementing these projects. Some 60 per cent of the Organization's operational budget is funded from support cost income generated by UNDP-financed technical co-operation activities. Since most of the UNIDO expenditure on support costs (mainly staff costs) is incurred in Austrian schillings, while support costs are fixed nominally in United States dollars, the operational budget is vulnerable to fluctuations in the dollar/schilling exchange rate (see

6/ *Ibid.*, para. 28.

para. 15 above). In 1990, the actual exchange rate varied from US\$1 = AS 10.40 to US\$1 = AS 12.00.

31. Further to the developments referred to in the previous Annual Report <sup>7/</sup> concerning UNDP support-cost arrangements, the UNDP Governing Council in June 1990 adopted decision 90/26 on new successor arrangements for agency support costs. The issue had also been discussed at the Industrial Development Board in June when decision IDB.6/Dec.22 was adopted, on the basis of which a statement of the President of the Board on the subject was forwarded to the President of the UNDP Governing Council for the attention of the Council.

32. The arrangements derived from UNDP Governing Council decision 90/26 are still being negotiated with UNDP (see para. 35 below). The decision distinguished between an essentially new approach to calculating support costs in respect of five major executing agencies (the Food and Agriculture Organization of the United Nations, the International Labour Organisation, the United Nations Educational, Scientific and Cultural Organization, UNIDO and the United Nations Department of Technical Co-operation for Development) and a continuation of the present system for all other executing agencies of UNDP-financed projects and programmes. It envisaged three distinct sets of services that the five major agencies would be expected to provide to UNDP operational activities:

(a) Technical support at the programme level including sectoral and subsectoral studies and analyses, policy advice and programme-level advice to Governments and UNDP;

(b) Technical support at the project level covering agency technical services to be provided to projects regardless of the modality of execution, specific mention being made of technical appraisal, monitoring and evaluation for which the agencies are normally considered to be the technical partners of the UNDP Administrator; and

(c) Administrative and operational support to projects including all non-technical services related to project implementation.

33. The decision also identified the related support cost payments. Two per cent of programmable resources were to be set aside for each of the first two facilities and to be managed centrally. Furthermore, a sum equivalent to 10 per cent of IPFs was to be transferred from resources previously housed in the support

cost line to a sub-line of the IPFs. The resources transferred to that sub-line could be used to finance support services from external agents and, in case of savings, could be drawn upon by Governments to finance administrative and operational services as required.

34. Whereas the Governing Council decision allows for more policy-level work by agencies and provides Governments with an incentive to assume charge of administrative and operational support to projects, the major agencies expressed concern that the amounts set aside, especially those for technical support services at the project level, were insufficient and would not ensure provision of adequate support. An initial assessment of the impact of the decision on the operational budget of UNIDO was given to the Programme and Budget Committee in conference room paper PBC.6/CRP.9, while external consultants commissioned by UNDP embarked on a survey of "clusters" of services and their average costs within the context of administrative and operational support to projects.

35. The Governing Council decision also called for consultations and co-operation between the Administrator and the agencies concerned so that the details of services and procedures could be elaborated and the methods devised for managing the different components of the new arrangements, thus paving the way for a final decision by the Governing Council at its session in June 1991. After an initial delay, these consultations were held in the last few months of 1990 and a progress report was to be submitted to the Governing Council session in February 1991. UNIDO played an active role in these consultations as a member of the Task Force on Support Costs, within the Consultative Committee on Substantive Questions (Operational Activities) of the Administrative Committee on Co-ordination.

36. At the present juncture, a full-scale assessment of the new successor arrangements and their impact would be premature (see chap. I, para. 13). A further element of uncertainty is inherent in the very complexity of the definition and identification of support costs. As recommended in Programme and Budget Committee conclusion 1989/4, the Secretariat undertook a review of the existing support cost identification system in UNIDO. It proposed an improved system that derived from its well-established methods of measuring and reporting support costs, but distinguished between the costs arising out of the execution of mandatory functions and the variable costs arising directly out of the technical co-operation functions (PBC.6/12). Application of the system permits identification of total support costs and the degree to which the regular budget contributes to those costs. Upon recommendation of the Programme and Budget Committee (conclusion 1990/6), which also requested the Director-General to take

<sup>7/</sup> Ibid., chap. VIII, paras. 32-33.



the steps necessary to ensure that all operational budget overhead income was spent on activities relating directly to technical co-operation, the Board, in its decision IDB.7/Dec.12, approved the new system of cost identification. The Board also requested that the system be communicated to UNDP and specialized agencies as a response to Governing Council decision 90/26, with the understanding that it should be further refined to take into account the impact on the operational budget of the three elements defined in paragraph 7 of the Governing Council decision. For comparison purposes, the figures given in table 2 below are calculated on the basis of the cost identification system used hitherto.

37. Technical co-operation delivery in 1990 reached \$159.6 million as compared to \$133.8 million in 1989; thus, the level of technical co-operation delivery increased by 19.3 per cent over the 1989 level. Full support costs in 1990, adjusted to a constant exchange rate of US\$1 = AS 15.30, amounted to \$42.4 million as compared to \$39.1 million in 1989; thus, support costs as a percentage of delivery decreased by 2.6 per cent over the 1989 level.

38. A statement of income and expenditures for programme support costs for 1990 will be provided in the interim financial performance report for the biennium 1990-1991.

## B. REGULAR BUDGET

39. Activities other than technical co-operation projects were financed from the regular budget of UNIDO. For the biennium 1990-1991 the General Conference approved appropriations of \$23,506,800 plus AS 1,718,425,770 (total equivalent of \$156,718,100 at US\$1 = AS 12.90). During 1990, the actual exchange rate varied from US\$1 = AS 10.40 to US\$1 = AS 12.00. The average exchange rate for the year was US\$1 = AS 11.43. UNIDO continued to experience serious cash-flow problems as a result of delayed receipt from and withholding of contributions by Member States. As of 31 December, total unpaid contributions represented 36.2 per cent of the 1990 assessments, an improvement compared with 1989 (43 per cent of the 1989 assessments).

40. Concerning the repayment of the United Nations loan, an amount of \$1 million was paid by UNIDO to the United Nations on 31 July in accordance with Board decision IDB.5/Dec.22(b)(i). At its seventh session, in decision IDB.7/Dec.8(b), the Board took note of the fact that, in the light of the current financial situation of UNIDO and the pattern of delayed or partial payments of assessed contributions, the Organization was not in a position to make accelerated payments in 1990 as provided for in Board decision IDB.5/Dec.22(b)(ii).

Table 2

Programme support costs, 1986 to 1990  
(in thousands of US dollars)

A. At actual dollar expenditure per year

	1986	1987	1988	1989	1990
Technical assistance delivery	99,600	97,700	119,800	133,800	159,600
Support costs a/					
Indirect	6,191	9,234	6,392	13,626	16,533
Direct	<u>25,128</u>	<u>31,365</u>	<u>33,045</u>	<u>30,105</u>	<u>36,194</u>
TOTAL	31,319	40,599	39,437	43,731	52,727
Exchange rate in AS	15.30	12.70	12.20	13.20	11.40

B. At a constant exchange rate of US\$1 = AS 15.30

	1986	1987	1988	1989	1990
Total support costs b/					
Dollar-based	7,203	9,338	9,071	10,058	12,127
Schilling-based	<u>24,116</u>	<u>25,949</u>	<u>24,214</u>	<u>29,051</u>	<u>30,251</u>
TOTAL	31,319	35,287	33,285	39,109	42,378
	1986 - 1987		1988 - 1989		1990
Total support costs	66,606		72,394		42,378
Technical assistance delivery	197,300		253,600		159,600
Support costs as a percentage of technical assistance	33.8		28.5		26.6

Note: The 1986-1987 biennium, the first biennium of UNIDO as a specialized agency, has been taken as a base.

a/ For 1989 and 1990, the Administrative Committee on Co-ordination definitions have been used, whereby for "indirect costs" read "non-technical support" and for "direct costs" read "technical support". The constituent items are not identical, therefore there is a different ratio between the two for 1989 and 1990.

b/ For 1990, the dollar-based expenditure is shown at 15 per cent (1986-1989 at 23 per cent) and schilling-based expenditure at 85 per cent (1986-1989 at 77 per cent) in line with regular budget estimates for 1990-1991.

## STATISTICAL ANNEX

### List of tables

	<u>Page</u>
1. Expenditures, 1972 to 1990 .....	102
2. Technical co-operation programmes: project budget approvals and expenditures, 1972 to 1990 .....	103
3A. Technical co-operation activities: projects approved in 1989 and 1990, by source of funds .....	107
3B. Technical co-operation activities: comparison of the value of projects as at 31 December 1989 and 31 December 1990, by source of funds .....	108
4. Expenditure on technical co-operation activities in 1989 and 1990, by source of funds and project component .....	109
5. Expenditure on technical co-operation activities in 1990, by source of funds and Department/Programme component .....	110
6. Expenditure on technical co-operation activities in 1990, by Department/Programme component and geographical area .....	111
7. Expenditure on technical co-operation activities, by geographical area, 1983 to 1990 .....	112
8. Technical co-operation activities: project expenditure in 1990 .....	113
9. Expenditure of regular budget and operational budget in 1990, by Department/Programme component and object of expenditure .....	114

Table 1  
Expenditures, 1972 to 1990  
(In millions of US dollars)

	1972-1976	1977-1981	1982-1986	1987	1988	1989	1990
Technical co-operation programmes	141.8	334.4	451.2	97.7	119.8	133.8	159.6
United Nations regular programme/ UNIDO regular budget	8.7	15.2	23.6	2.1	2.5	6.3 <sup>a/</sup>	4.5
UNDP/IPF and cash counterpart	98.7	229.9	291.3	66.5	74.0	76.8	88.7
UNDP/SIS	14.3	17.2	14.4	2.8	3.0	3.0	5.2
UNDP/special programme resources and special measures	3.1	5.3	3.1	0.3	-	0.2	0.4
UNDP-administred trust funds	-	3.4	12.9	1.1	1.0	2.3	1.7
Other trust funds	6.2	17.9	34.7	6.1	14.2	16.5	25.7
UNIDF/IDF	10.8	41.9	63.4	16.6	19.8	23.0	27.9
United Nations Fund for Drug Abuse control (UNFDAC)	-	-	2.2	0.6	2.8	1.2	2.2
Non-UNIDO funds	-	3.6	5.6	1.6	2.5	4.5	3.3
Headquarters	100.5	202.4	258.2	76.1	71.7	97.7	95.9
Regular budget	85.2	160.7	199.8	60.7	56.9	82.1	76.3
Overheads	15.3	41.7	58.4	15.4	14.8	15.6	19.6
Total expenditure	242.3	536.8	709.4	173.3	191.5	231.5	255.5
Technical co-operation programmes as percentage of total expenditure	58.5%	62.3%	63.6%	56.2%	62.6%	57.8%	62.5%

<sup>a/</sup> Includes regular programme and Industrial Development Decade for Africa (see appendix C).

**Table 2**  
**Technical co-operation programmes: project budget approvals and expenditures, 1972 to 1990**

(In millions of US dollars)

	1972-76	1977-81	1982-86	1987 a/	1988	1989	1990
<b>A. All sources of funds</b>							
1. Residual value of projects brought forward	37.4	72.8	136.4	155.9	175.4	217.0	252.5
2. Value of project budgets approved in the year (net)	177.2	398.0	470.6	117.2	161.4	169.3	162.7
3. Total of approved projects under implementation	214.6	470.8	607.0	273.1	336.8	386.3	415.2
4. Expenditures in the year	141.8	334.4	451.1	97.7	119.8	133.8	159.6
5. Residual value of projects carried forward	72.8	136.4	155.9	175.4	217.0	252.5	255.6
<b>B. United Nations regular programme b/ UNIDO regular budget</b>							
1. Residual value of projects brought forward	-	-	-	1.2	-	4.6	-
2. Value of project budgets approved in the year (net)	8.7	15.2	24.8	0.9	7.1	1.7	8.3
3. Total of approved projects under implementation	8.7	15.2	24.8	2.1	7.1	6.3	8.3
4. Expenditures in the year	8.7	15.2	23.6	2.1	2.5	6.3	4.5
5. Residual value of projects carried forward	-	-	1.2	-	4.6	-	3.8
<b>C. UNDP/IPF and cash counterpart</b>							
1. Residual value of projects brought forward	29.7	59.8	105.8	99.3	116.0	151.5	153.3
2. Value of project budgets approved in the year (net)	128.8	275.9	284.8	83.2	109.5	78.6	81.4
3. Total of approved projects under implementation	158.5	335.7	390.6	182.5	225.5	230.1	234.7
4. Expenditures in the year	98.7	229.9	291.3	66.5	74.0	76.8	88.7
5. Residual value of projects carried forward	59.8	105.8	99.3	116.0	151.5	153.3	146.0

Table 2 (continued)

	1972-76	1977-81	1982-86	1987 a/	1988	19899	1990
<u>D. UNDP/SIS c/</u>							
1. Residual value of projects brought forward	5.3	5.8	2.8	3.1	2.1	2.5	4.7
2. Value of project budgets approved in the year (net)	14.8	14.2	14.7	1.8	3.4	5.2	5.3
3. Total of approved projects under implementation	20.1	20.0	17.5	4.9	5.5	7.7	10.0
4. Expenditures in the year	14.3	17.2	14.4	2.8	3.0	3.0	5.2
5. Residual value of projects carried forward	5.8	2.8	3.1	2.1	2.5	4.7	4.8
<u>E. UNDP/special programme resources and special measures</u>							
1. Residual value of projects brought forward	-	1.7	0.9	0.3	-	-	0.5
2. Value of project budgets approved in the year (net)	4.8	4.5	2.5	-	-	0.7	0.3
3. Total of approved projects under implementation	4.8	6.2	3.4	0.3	-	0.7	0.8
4. Expenditures in the year	3.1	5.3	3.1	0.3	-	0.2	0.5
5. Residual value of projects carried forward	1.7	0.9	0.3	-	-	0.5	0.3
<u>F. UNDP-administered trust funds d/</u>							
1. Residual value of projects brought forward	-	-	4.7	1.5	0.1	0.1	0.6
2. Value of project budgets approved in the year (net)	-	8.1	9.7	(0.1)	1.0	2.8	1.3
3. Total of approved projects under implementation	-	8.1	14.4	1.4	1.1	2.9	1.9
4. Expenditures in the year	-	3.4	12.9	1.3	1.0	2.3	1.7
5. Residual value of projects carried forward	-	4.7	1.5	0.1	0.1	0.6	0.2

Table 2 (continued)

	1972-76	1977-81	1982-86	1987 a/	1988	1989	1990
<b>G. <u>Other trust funds g/</u></b>							
1. Residual value of projects brought forward	0.4	1.3	5.7	28.7	26.4	24.0	48.8
2. Value of project budgets approved in the year (net)	7.1	22.3	57.7	3.7	11.8	41.3	27.2
3. Total of approved projects under implementation	7.5	23.6	63.4	32.3	38.2	65.3	76.0
4. Expenditures in the year	6.2	17.9	34.7	6.0	14.2	16.5	25.7
5. Residual value of projects carried forward	1.3	5.7	28.7	26.4	24.0	48.8	50.3
<b>H. <u>UNIDF f/ / IDF</u></b>							
1. Residual value of projects brought forward	2.0	4.2	14.6	17.6	22.3	28.9	37.6
2. Value of project budgets approved in the year (net)	13.0	52.3	66.4	21.3	26.4	31.7	30.8
3. Total of approved projects under implementation	15.0	56.5	81.0	38.9	48.7	60.6	68.4
4. Expenditures in the year	10.8	41.9	63.4	16.6	19.8	23.0	27.9
5. Residual value of projects carried forward	4.2	14.6	17.6	22.3	28.9	37.6	40.5
<b>I. <u>UNFDAC</u></b>							
1. Residual value of projects brought forward	-	-	-	0.3	0.1	0.9	1.4
2. Value of project budgets approved in the year (net)	-	-	2.5	0.4	3.6	1.7	2.2
3. Total of approved projects under implementation	-	-	2.5	0.7	3.7	2.6	3.6
4. Expenditures in the year	-	-	2.2	0.6	2.8	1.2	2.2
5. Residual value of projects carried forward	-	-	0.3	0.1	0.9	1.4	1.4

Table 2 (continued)

	1972-76	1977-81	1982-86	1987 a/	1988	1989	1990
J. <u>Non-UNIDO funds</u> g/							
1. Residual value of projects brought forward	-	-	1.9	4.0	8.4	4.5	5.6
2. Value of project budgets approved in the year (net)	-	5.5	7.6	6.0	(1.4)	5.6	5.8
3. Total of approved projects under implementation	-	5.5	9.5	10.0	7.0	10.1	11.4
4. Expenditures in the year	-	3.6	5.5	1.6	2.5	4.5	3.2
5. Residual value of projects carried forward	-	1.9	4.0	8.4	4.5	5.6	8.2

a/ Some of the 1987 figures differ slightly from those reflected in document IDB.4/10 owing to minor accounting adjustments.

b/ Excludes the value of projects approved but not implemented within the year (prior to 1978) or within the biennium (after 1977), as appropriate.

c/ Includes SIS trust funds prior to 1973.

d/ Includes United Nations Trust Fund for Sudano-Sahelian Activities; United Nations Financing System for Science and Technology for Development; UNOP trust fund for projects financed by the United Nations Development Fund for Women; United Nations Capital Development Fund; third-party trust funds.

e/ Includes special-purpose trust funds financed by recipient or third parties; government cash counterpart contributions paid to UNIDO; United Nations Population Fund; projects financed from World Bank loans.

f/ Includes UNIDO General Trust Fund.

g/ Includes projects executed by other agencies for which UNIDO is the associated or co-operating agency.



Table 3A

## Technical co-operation activities: projects approved in 1989 and 1990, by source of funds

Source of funds	New projects approved			Existing projects revised			Total net value of approvals/revisions (\$000)
	Number of projects	Net value of approvals (\$000)	Average value of approvals (\$000)	Number of projects	Net value of revisions (\$000)	Average value of revisions (\$000)	
	1989						
UNIDO regular budget	105	3,644	35	76	90	1	3,734
UNDP/IPF and cash counterpart	123	47,322	385	720	31,248	43	78,070
UNDP/SIS	84	4,934	59	123	215	2	5,149
UNDP/special programme resources and special measures	3	691	230	4	5	1	696
UNDP-administered trust funds	19	2,931	154	25	116	5	3,047
Other trust funds	64	45,033	704	110	(3,634)	(33)	41,399
IDF	179	31,957	179	345	(224)	(1)	31,733
UNFDAC	13	1,754	135	7	(142)	(20)	1,612
Non-UNIDO funds	18	5,548	308	44	44	1	5,592
TOTAL	608	143,814	237	1,454	27,718	19	171,532
	1990						
UNIDO regular budget	162	8,320	51	0	0	0	8,320
UNDP/IPF and cash counterpart	102	50,270	493	670	31,126	46	81,396
UNDP/SIS	91	5,444	60	162	(114)	(1)	5,330
UNDP/special programme resources and special measures	0	0	0	3	179	60	179
UNDP-administered trust funds	16	1,292	81	23	7	0	1,299
Other trust funds	111	15,991	144	129	11,236	87	27,227
IDF	207	31,569	153	360	(723)	(2)	30,846
UNFDAC	20	2,893	145	4	(677)	(169)	2,216
Non-UNIDO funds	23	5,701	248	28	180	6	5,881
TOTAL	732	121,480	166	1,379	41,214	30	162,694

Table 3B

Technical co-operation activities: comparison of the value of projects as at  
31 December 1989 and 31 December 1990, by source of funds

	Number of projects		Total value of projects (\$000)		Average value of projects (\$000)	
	1989	1990	1989	1990	1989	1990
UNIDO regular budget	231	162	10,929	8,320	47	51
UNDP/IPF and cash counterpart	922	861	578,424	569,725	627	662
UNDP/SIS	271	298	12,789	15,903	47	53
UNDP/special programme resources and special measures	8	3	2,379	869	297	290
UNDP-administered trust funds	52	58	15,115	6,214	291	107
Other trust funds	228	310	92,224	123,054	404	397
IDF	677	687	107,048	124,138	158	181
UNFDAC	28	40	7,113	7,887	254	197
Non-UNIDO funds	84	86	18,086	21,466	215	250
TOTAL	2,501	2,505	844,107	877,576	338	350

The following is a breakdown by status of projects:

	Number of projects		Total value of projects (\$000)	
	1989	1990	1989	1990
New and ongoing	1,628	1,717	633,887	698,630
Operationally completed	181	181	47,008	42,166
Financially completed	692	607	163,212	136,780
TOTAL	2,501	2,505	844,107	877,576

Table 4

Expenditure on technical co-operation activities in 1989 and 1990,  
by source of funds and project component

	<u>Project personnel</u>		<u>Subcontracts</u>	<u>Fellowships &amp; training</u>	<u>Equipment</u>	<u>Miscellaneous expenses</u>	<u>Total</u>
	<u>Number of experts' work-months a/</u>	<u>\$000</u>					
		<u>\$000</u>	<u>\$000</u>	<u>\$000</u>	<u>\$000</u>	<u>\$000</u>	<u>\$000</u>
	1989						
UNIDO regular budget	220.2	2,685	728	1,776	914	220	6,323
UNDP/IPF and cash counterpart	4,057.3	25,930	12,897	10,718	25,391	1,817	76,753
UNDP/SIS	211.4	2,098	310	221	252	80	2,961
UNDP/special programme resources and special measures	12.0	107	0	0	45	3	155
UNDP-administered trust funds	34.7	218	958	963	174	30	2,343
Other trust funds	3,862.2	13,706	319	449	1,968	67	16,509
IDF	941.3	8,256	2,834	5,271	5,552	1,072	22,985
UNFDAC	0.4	50	6	23	1,109	8	1,196
Non-UNIDO funds	130.9	1,295	395	808	2,028	31	4,557
TOTAL	9,470.4	54,345	18,447	20,229	37,433	3,328	133,782
	1990						
UNIDO regular budget	254.0	1,723	968	698	849	251	4,489
UNDP/IPF and cash counterpart	4,411.4	33,845	10,956	12,316	29,313	2,237	88,667
UNDP/SIS	236.6	2,595	1,589	490	444	100	5,218
UNDP/special programme resources and special measures	33.6	363	7	15	55	5	445
UNDP-administered trust funds	29.9	283	(30)	1,032	233	198	1,716
Other trust funds	4,541.9	16,881	3,653	807	3,868	517	25,726
IDF	1,382.2	11,793	3,051	6,850	4,992	1,223	27,909
UNFDAC	2.0	52	0	85	2,009	0	2,146
Non-UNIDO funds	106.0	1,295	381	922	604	40	3,242
TOTAL	10,997.6	68,830	20,575	23,215	42,367	4,571	159,558

a/ Categories are as follows:

	<u>Work-months</u>
International experts and consultants	8,575.8
Operational assistance experts	12.0
National experts	<u>2,409.8</u>
TOTAL	<u>10,997.6</u>

Table 5

Expenditure on technical co-operation activities in 1990, by source of funds and Department/programme component

(In thousands of US dollars)

Department/programme component	Regular budget	UNOP/ IPF and cash counter- part	UNDP/SIS	UNDP/ special programme resources and special measures	UNDP- admini- stered trust funds	Other trust funds	IDF	UNFDAC	Non- UNIDO funds	Total
Executive Direction and Management	0	0	0	0	0	103	96	0	0	199
Programme and Project Development	397	450	95	0	0	3,324	1,267	0	113	5,646
Industrial Promotion, Consultations and Technology										
Industrial Investment	123	1,855	107	0	0	709	5,633	0	0	8,427
System of Consultations	47	0	0	0	0	69	130	0	0	246
Industrial Technology Promotion	323	199	89	0	0	155	467	0	11	1,244
Industrial Technology Development	74	268	9	0	0	8,394	2,344	0	60	11,149
Subtotal	567	2,322	205	0	0	9,327	8,574	0	71	21,066
Industrial Operations										
Agro-based Industries	74	8,643	507	0	8	403	6,682	(14)	600	16,903
Chemical Industries	814	21,079	1,512	0	0	6,596	3,147	0	596	33,744
Metallurgical Industries	404	7,085	487	7	121	233	739	0	242	9,318
Engineering Industries	293	15,009	679	18	322	3,171	385	0	331	20,208
Industrial Planning	459	8,194	826	260	13	384	257	0	218	10,611
Institutional Infrastructure	120	15,679	342	0	0	914	1,954	0	351	19,360
Industrial Management and Rehabilitation	652	5,634	444	160	0	737	79	0	163	7,869
Feasibility Studies	288	3,636	76	0	0	297	1,368	0	209	5,874
Industrial Human Resource Development	424	936	45	0	1,252	89	3,352	0	44	6,142
Subtotal	3,528	85,895	4,918	445	1,716	12,824	17,963	(14)	2,754	130,029
External Relations, Public Information, Language and Documentation Services	0	0	0	0	0	0	7	0	0	7
Other	(3)	0	0	0	0	148	2	2,160	304	2,611
TOTAL	4,489	88,667	5,218	445	1,716	25,726	27,909	2,146	3,242	159,558

Table 6

## Expenditure on technical co-operation activities in 1990, by Department/programme component and geographical area

(In thousands of US dollars)

Department/programme component unit	Africa a/	Arab States b/	Asia and the Pacific	Europe	Latin America and Caribbean	Global and interregional	Total
Executive Direction and Management	-	-	-	-	-	199	199
Programme and Project Development	1,471	409 (266)	991	25	477	2,539	5,646
Industrial Promotion, Consultations and Technology							
Industrial Investment	613	75 -	1,208	115	969	5,447	8,427
System of Consultations	23	38 -	-	-	78	107	246
Industrial Technology Promotion	404	93 (93)	210	-	108	522	1,244
Industrial Technology Development	143	9 (9)	72	70	219	10,645	11,149
Subtotal	1,183	215 (102)	1,490	185	1,374	16,721	21,066
Industrial Operations							
Agro-based Industries	7,607	1,250 (1,222)	7,321	34	1,474	439	16,903
Chemical Industries	12,029	8,570 (8,282)	17,100	1,467	1,158	1,702	33,744
Metallurgical Industries	2,364	626 (569)	5,439	437	386	635	9,318
Engineering Industries	7,889	2,145 (1,711)	6,697	999	1,111	3,078	20,208
Industrial Planning	6,533	1,293 (168)	1,943	59	839	112	10,611
Institutional Infrastructure	7,504	2,942 (613)	4,408	589	2,915	1,615	19,360
Industrial Management and Rehabilitation	3,659	1,344 (942)	2,512	126	1,116	54	7,869
Feasibility Studies	2,844	1,856 (520)	759	48	168	719	5,874
Industrial Human Resource Development	1,788	250 (84)	352	329	185	3,322	6,142
Subtotal	52,217	20,276 (14,111)	46,531	4,088	9,352	11,676	130,029
External Relations, Public Information, Language and Documentation Services	9	-	-	-	-	(2)	7
Other	801	698 (345)	372	938	-	147	2,611
TOTAL	55,681	21,598 (14,824)	49,384	5,236	11,203	31,280	159,558

a/ Includes figures related to country projects in African Arab States.

b/ Figures in parentheses relate to country projects in African Arab States only and are deducted from the column "Total" since they are already included under "Africa".

Table 7

## Expenditure on technical co-operation activities, by geographical area, 1983 to 1990

(In thousands of US dollars)

Area	1983	1984	1985	1986	1987	1988	1989	1990
<b>Africa</b>								
Country projects a/	25,683	25,300	31,431	31,674	29,102	34,042	40,802	47,849
Regional projects	1,773	4,713	5,791	4,069	3,468	4,389	8,323	7,832
Subtotal	27,456	30,013	37,222	35,743	32,570	38,431	49,125	55,681
<b>Arab States</b>								
Country projects	11,274	11,807	11,448	11,153	11,934	17,714	19,107	21,071
Regional projects	593	1,104	532	731	616	299	172	527
Country projects (African Arab States) b/	(7,030)	(8,806)	(9,123)	(8,505)	(9,560)	(12,753)	(13,725)	(14,824)
Subtotal	4,837	4,105	2,657	3,379	2,990	5,260	5,554	6,774
<b>Asia and the Pacific</b>								
Country projects	23,599	29,795	29,313	35,419	36,620	41,974	41,506	46,621
Regional projects	1,062	1,437	1,088	1,654	1,311	1,953	2,099	2,763
Subtotal	24,661	31,232	30,401	37,073	37,931	43,927	43,605	49,384
<b>Europe</b>								
Country projects	2,513	3,609	3,047	3,022	2,307	3,845	3,776	4,837
Regional projects	248	49	39	208	318	432	515	399
Subtotal	2,761	3,658	3,086	3,230	2,625	4,277	4,291	5,236
<b>Latin America and the Caribbean</b>								
Country projects	9,168	7,987	11,082	9,402	8,463	9,653	11,029	9,356
Regional projects	877	1,013	936	1,148	839	1,137	1,046	1,847
Subtotal	10,045	9,000	12,018	10,550	9,302	10,790	12,075	11,203
<b>Global and interregional projects</b>								
	8,259	9,183	8,884	9,625	12,308	17,095	19,132	31,280
TOTAL	78,019	87,191	94,468	99,600	97,726	119,780	133,782	159,558

a/ Includes African Arab States.

b/ Figures deducted since already included under "Africa".

**Table 8**  
**Technical co-operation activities: project expenditure in 1990**  
(In thousands of US dollars)

	Africa <sup>a/</sup>	Arab States <sup>b/</sup>	Asia and the Pacific	Europe	Latin America and Caribbean	Global and interregional	Total	
<b>A. By source of funds and geographical area</b>								
UNIDO regular budget	2,919	842	(761)	624	83	290	492	4,489
UNDP/IPF and cash counterpart	31,732	11,702	(6,380)	41,685	3,044	6,884	-	88,667
UNDP/SIS	2,585	470	(380)	896	667	980	-	5,218
UNDP/special programme resources and special measures	-	160	-	285	-	-	-	445
UNDP-administered trust funds	245	-	-	72	-	-	1,399	1,716
Other trust funds	8,412	6,016	(5,952)	1,230	361	627	15,032	25,726
IDF	8,092	1,079	(568)	2,703	139	2,130	14,334	27,909
UNFDAC	801	698	(345)	68	938	(14)	-	2,146
Non-UNIDO funds	895	631	(438)	1,821	4	306	23	3,242
<b>TOTAL</b>	<b>55,681</b>	<b>21,598</b>	<b>(14,824)</b>	<b>49,384</b>	<b>5,236</b>	<b>11,203</b>	<b>31,280</b>	<b>159,558</b>
<b>B. By project component and geographical area</b>								
Project personnel	27,008	11,961	(7,794)	14,794	1,105	7,377	14,379	68,830
Subcontracts	8,189	2,823	(2,513)	6,043	411	670	4,952	20,575
Fellowships and training	4,602	1,374	(722)	9,533	1,307	1,320	5,801	23,215
Equipment	14,043	4,923	(3,373)	18,103	2,325	1,512	4,834	42,367
Miscellaneous	1,839	517	(422)	911	88	324	1,314	4,571
<b>TOTAL</b>	<b>55,681</b>	<b>21,598</b>	<b>(14,824)</b>	<b>49,384</b>	<b>5,236</b>	<b>11,203</b>	<b>31,280</b>	<b>159,558</b>

<sup>a/</sup> Includes figures related to country projects in African Arab States.

<sup>b/</sup> Figures in parentheses relate to country projects in African Arab States only and are deducted from the column "Total" since they are already included under "Africa".

Table 9

Expenditure of regular budget and operational budget in 1990,  
by Department/programme component and object of expenditure a/

(In thousands of US dollars)

Department/programme component	Staff costs	Consultants	Expert group meetings	Other	Total
Policy-making Organs	173	0	0	734	907
Executive Direction and Management	3,006	3	39	209	3,257
Programme and Project Development					
Area Programmes	6,671	751	33	630	8,085
Industrial Policy and Perspectives	4,854	262	30	168	5,314
Industrial Co-operation/Funds Mobilization	1,171	22	0	23	1,216
ICFM/Industrial Co-operation	1,606	6	0	78	1,690
Special Measures and Activities	2,771	35	0	464	3,270
Office of the Deputy Director-General	564	0	0	29	593
	17,637	1,076	63	1,392	20,168
Industrial Promotion, Consultations and Technology					
Industrial Investment	1,969	30	41	95	2,135
System of Consultations	2,183	79	86	152	2,500
Industrial Technology Promotion	2,243	124	1	103	2,471
Industrial Technology Development	1,690	79	5	240	2,014
Office of the Deputy Director-General	531	6	0	10	547
	8,616	318	133	600	9,667
Industrial Operations					
Industrial Institutions and Services	4,967	26	23	128	5,144
Industrial Operations Technology	7,638	78	28	209	7,953
Industrial Operations Support	6,963	9	3	119	7,094
Interregional Advisers	740	0	0	102	842
Office of the Deputy Director-General	1,647	21	0	53	1,721
	21,955	134	54	611	22,754
External Relations, Public Information, Language and Documentation Services					
External Relations	1,918	0	0	269	2,187
Public Relations and Information	686	0	0	142	828
Languages and Documentation	8,297	0	0	141	8,438
Office of the Deputy Director-General	491	0	0	29	520
	11,392	0	0	581	11,973
Administration					
Financial Services	4,622	60	0	23	4,705
Personnel Services	3,201	2	0	636	3,839
General Services	10,031	18	0	10,274	20,323
Elec. Data-processing/Office Automation	1,951	18	0	5,052	7,021
Office of the Deputy Director-General	837	0	0	2,832	3,669
	20,642	98	0	18,817	39,557
<b>Total expenditure</b>	<b>83,421</b>	<b>1,629</b>	<b>289</b>	<b>22,944</b>	<b>108,283</b>
<b>Income</b>					<b>12,374</b>
<b>GRAND TOTAL</b>					<b>95,909</b>

a/ Expenditure for technical co-operation (IDDA and the regular programme) excluded.



## APPENDICES

### CONTENTS

	<u>Page</u>
A. UNIDO organization chart .....	116
B. Expert group meetings, symposia, seminars, workshops, courses and other meetings of a non-training character held during 1990 .....	118
C. Technical co-operation - regular budget allocations for the biennium 1990-1991 and deliveries in 1990.....	123
D. Geographical distribution of experts .....	124
E. UNIDO involvement in UNDP country programmes .....	126
F. Major studies, reports and series publications issued by UNIDO in 1990 .....	128
G. UNIDO technical assistance to the least developed countries, 1 January to 31 December 1990 .....	129
H. Industrial Development Fund .....	135
I. Training activities in 1990 .....	147
J. Agreements concluded by UNIDO in 1990.....	157

UNIDO Organization Chart  
as at 31 December 1990

DIRECTOR-GENERAL

116

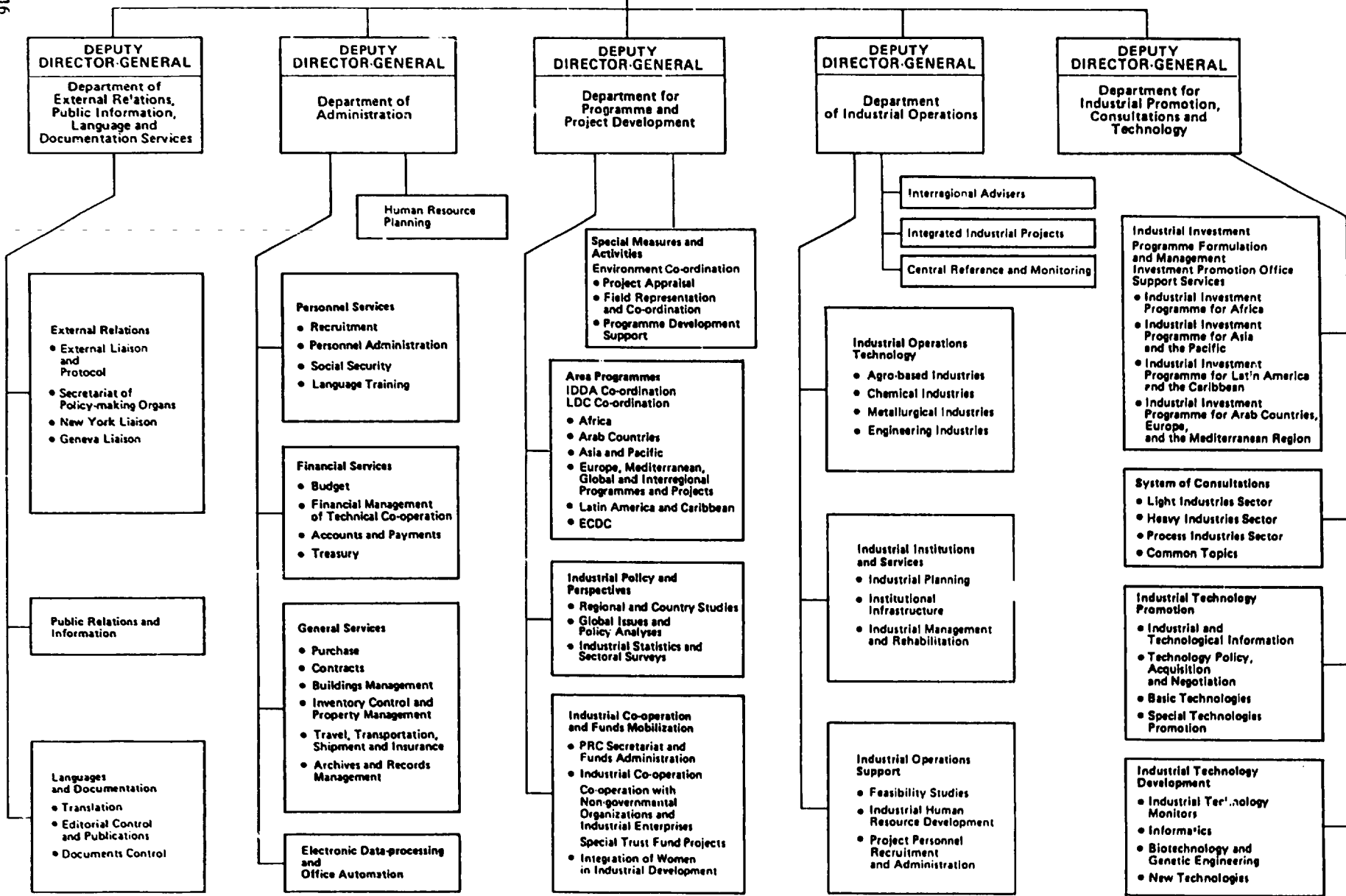

Appendix A

APPENDIX A

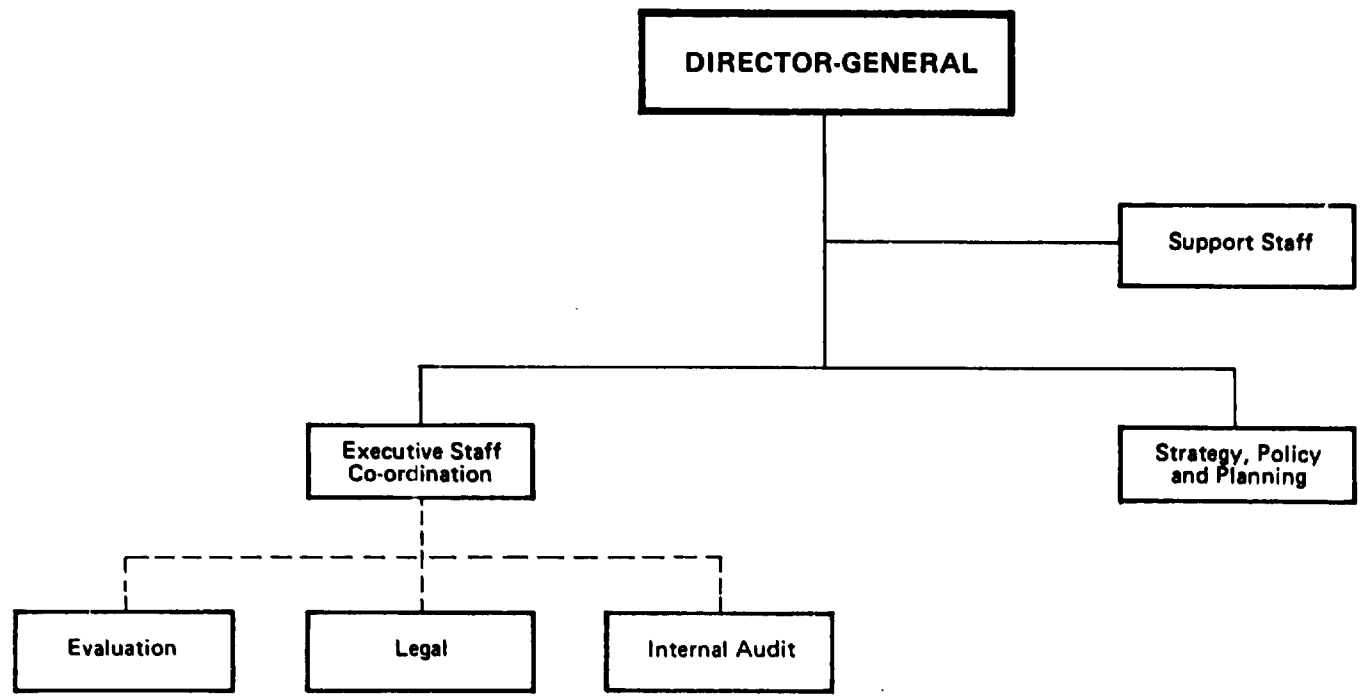

## APPENDIX B

EXPERT GROUP MEETINGS, SYMPOSIA, SEMINARS, WORKSHOPS, COURSES AND  
OTHER MEETINGS OF A NON-TRAINING CHARACTER HELD DURING 1990

Date		Place
OFFICE OF THE DIRECTOR-GENERAL		
7-9 May	Special Advisory Group to the Director-General, fourth session	Vienna Austria
DEPARTMENT OF EXTERNAL RELATIONS, PUBLIC INFORMATION, LANGUAGE AND DOCUMENTATION SERVICES		
28 May - 1 June	Industrial Development Board, sixth session	Vienna Austria
25-29 June	Programme and Budget Committee, sixth session	Vienna Austria
5-9 November	Industrial Development Board, seventh session	Vienna Austria
DEPARTMENT FOR PROGRAMME AND PROJECT DEVELOPMENT		
<u>Special Measures and Activities Division</u>		
10-14 December	Regional meeting on management of industrial wastewater	Paris France
<u>Area Programmes Division</u>		
5-7 March	Project assessment meeting for the promotion of joint ventures	Istanbul Turkey
3-5 April	Meeting on the promotion of industrial co-operation in Cameroon	Yaoundé Cameroon
18-20 April	Workshop on information system on technologies and projects with special emphasis on small and medium enterprises	Bled Yugoslavia
3-6 October	Meeting on industrial co-operation among member countries of the Arab Maghreb Union	Tunis Tunisia
6-7 October	Second follow-up subregional meeting on the promotion of intra-African industrial co-operation within the framework of the Industrial Development Decade for Africa	Tunis Tunisia
15-23 October	Workshop-cum-study tour on industrial utilization of medicinal plants	Beijing China
12-15 November	UNIDO/ESCAP regional workshop on agro- related metalworking industries in Asian and Pacific least developed countries	Bangkok Thailand
26-30 November	Solidarity ministerial meeting for co-operation in the industrial development of the People's Democratic Republic of Ethiopia	Addis Adaba Ethiopia
<u>Industrial Co-operation and Funds Mobilization Division</u>		
27-30 March	Expert group meeting on the establishment of an industrial co-operative development strategy in Latin America	San José Costa Rica

Date		Place
1-3 October	Seminar on promotion of industrial co-operation and foreign investment in Yugoslavia	Belgrade Yugoslavia
<u>Industrial Policy and Perspectives Division</u>		
4-6 April	High-level workshop on industrial restructuring in Costa Rica	San José Costa Rica
27-29 June	Expert group meeting on non-ferrous metals	Vienna Austria
17 August	National seminar on industrial and technological development in Bolivia	La Paz Bolivia
3-5 October	Meeting on the development of industrial co-operation among the member countries of the Arab Maghreb Union	Tunis Tunisia
11-12 October	National seminar on Viet Nam's future industrial development	Hanoi Viet Nam
DEPARTMENT OF INDUSTRIAL OPERATIONS		
<u>Office of the Deputy Director-General</u>		
11-15 June	Interregional symposium on the role of the industrial co-operative movement in economic and industrial development	Moscow Union of Soviet Socialist Republics
<u>Industrial Operations Technology Division</u>		
8-12 January	Expert group meeting on design, development and manufacture of simple food processing and preserving equipment	Niamey Niger
12-16 February	Euro-Arab workshop on computerized maintenance management systems	Prague Czechoslovakia
7-10 May	Expert group meeting on new industrial maintenance techniques	Rabat Morocco
21-24 August	Expert group meeting on control and regulatory measures concerning motor vehicle emissions in the Asia and Pacific region	Seoul Republic of Korea
10-13 September	Workshop on safety in chemical production	Basel Switzerland
12-19 September	Expert group meeting on industrial ecologically clean crop production systems in artificial climate	Moscow Union of Soviet Socialist Republics
1-5 October	Seminar/workshop on thermal processing of biomass for energy	London United Kingdom
2-5 October	International seminar on newsprint production from bagasse	Havana Cuba
8-12 October	International seminar on recent developments in the field of pesticides and their application to pest control in China and other developing countries of the region	Shenyang China
8-13 October	Tannery machinery maintenance seminar	Addis Ababa Ethiopia

Date		Place
19-23 November	Hides and skins improvement seminar	Bulawayo Zimbabwe
10-14 December	Workshop on environment protection in highly industrialized regions and utilization of low-waste/non-waste technologies in basic industries	Ostrava Czechoslovakia
<u>Industrial Institutions and Services Division</u>		
15-18 January	Expert meeting on computer-aided tools for environmental impact assessment for industrial planning	Vienna Austria
29 January - 2 February	Expert group meeting on the development and integration of small and medium industries in the ALADI member States based on the use of the ACT system	Montevideo Uruguay
12-16 March	High-level expert group meeting on further development of the UNIDPLAN programme for 1990-1995	Vienna Austria
2-4 April	Second meeting of international experts on a regional programme on industrial automation of the capital goods sector of Latin America	Vienna Austria
25-29 June	Expert group meeting on industrial information and strategic analyses systems	Vienna Austria
12-15 November	Expert group meeting on environment monitoring for an aluminium plant in Pleven, Bulgaria	Vienna Austria
27-30 November	Workshop on incubators of entrepreneurship and strategies to stimulate innovation among small and medium industries in Europe	Trieste Italy
4-6 December	Workshop to exchange experiences and build a concept of regional action in standardization and quality control	Geneva Switzerland
<u>Industrial Operations Support Division</u>		
18-22 June	Expert group meeting on continuous in-plant training for French-speaking sub-Saharan African countries	Paris France
DEPARTMENT FOR INDUSTRIAL PROMOTION, CONSULTATIONS AND TECHNOLOGY		
<u>Industrial Investment Division</u>		
14 February	Country presentation and investment promotion meeting - Nepal	Seoul Republic of Korea
20-27 February	Country presentation and investment promotion meeting - Nepal (presentations in Kobe, Nagoya, Osaka and Tokyo)	Japan
28 February	Country presentation and investment promotion meeting - Thailand	Zurich Switzerland
26 April	Country presentation and investment promotion meeting - India and Nepal	Milan Italy
7-8 May	First Arab investment forum for electronics	Algiers Algeria

Date		Place
21-24 May	Second investors forum for the promotion of foreign investment	Warsaw Poland
21-25 May	Country presentation and investment promotion meeting - China (presentations in Seoul, Suwon, Changwon and Pohang)	Republic of Korea
2-3 June	Country presentation and investment promotion meeting related to packaging industries of China and ASEAN countries	Banz, Düsseldorf Federal Republic of Germany
18-22 June	Regional forum for promotion of industrial investment projects for PTA member countries	Nairobi Kenya
1-3 October	Investment forum for Yugoslavia	Belgrade Yugoslavia
12-13 October	Meeting on the requirements for the promotion of investment projects in the tourism industry	Morocoy Venezuela
18-21 October	Meeting on co-operative arrangements among selected partners on specific investment projects	Santa Cruz Bolivia
27 October - 7 November	Country presentation and investment promotion meeting - Sri Lanka (presentations in Canada and the United States)	North America
28 October - 13 November	Country presentation and investment promotion meeting - Viet Nam (presentations in Australia, Japan and Hong Kong)	Asia and Australia
12-22 November	Country presentation and investment promotion meeting - Sri Lanka (presentations in Austria, Belgium, Germany, Italy, the Netherlands and the United Kingdom)	Europe
18 November - 4 December	Country presentation and investment promotion meeting - Viet Nam (presentations in Austria, France, Germany, Italy and Sweden)	Europe
25 November - 4 December	Country presentation and investment promotion meeting - Sri Lanka (presentations in Hong Kong and the Republic of Korea)	Asia
6-12 December	Country presentation and investment promotion meeting - Sri Lanka (presentations in Japan, Singapore and Thailand)	Asia
<u>System of Consultations Division</u>		
3-6 January	African expert group meeting on the processing and utilization of phosphates	Dakar Senegal
12-16 February	Workshop on co-operation among developing countries on plastics in agriculture in arid and semi-arid zones	Algiers Algeria
19-22 March	Interregional meeting on co-operation among developing countries for the development of the pharmaceutical industry	New Delhi India
24-27 April	Global preparatory meeting for the second Consultation on the wood and wood products industry	Nairobi Kenya

Appendix B

Date		Place
5-8 June	Expert group meeting for the African region in promoting regional co-operation for the establishment of an organizational framework for sugar-cane producers and co-operation on technology and market	Vienna Austria
23-26 July	Regional expert group meeting on production complementarities in the aluminium industry in Latin America	Kingston Jamaica
10-14 September	Workshop on the fisheries industry in the Caribbean islands	Port-of-Spain Trinidad and Tobago
12-16 November	Regional consultation on industrial rehabilitation/restructuring with special focus on the food-processing subsector in Africa	Vienna Austria
<u>Industrial Technology Promotion Division</u>		
23-25 January	Seminar on industrialization through standardization and quality control	Bangkok Thailand
14-25 May	Joint UNIDO/UNESCO/IAS workshop on the use of personal computers in on-line access to technological data bases	Moscow Union of Soviet Socialist Republics
28-31 May	International symposium on the future of scientific, technological and industrial information services	Leningrad Union of Soviet Socialist Republics
31 May	<u>Ad hoc</u> industry meeting on phasing out ozone-depleting substances	Vienna Austria
17-22 September	Workshop for the promotion of industrial information networking among selected Latin American and Caribbean countries	Havana Cuba
3-5 October	Workshop on the development and establishment of a Latin American technology market	Lima Peru
5-8 November	TIES expert meeting on programme and methodology of teaching for technology transfer negotiators	Vienna Austria
<u>Industrial Technology Development Division</u>		
3-12 September	Workshop for African and Arab country representatives from the telecommunication industry	New Delhi India



## APPENDIX C

TECHNICAL CO-OPERATION - REGULAR BUDGET ALLOCATIONS  
FOR THE BIENNIUM 1990-1991 AND DELIVERIES IN 1990

(In thousands of US dollars)

Component	Allocation for the biennium 1990-1991	Delivery in 1990
<b>A. REGULAR PROGRAMME OF TECHNICAL CO-OPERATION (RP)</b>		
Training for developing countries' personnel in various industrial fields		
Individual fellowships	604.6	137.5
Group training programmes	1,542.5	653.8
Establishment and strengthening of training facilities in developing countries	503.8	465.5
Special needs of the least developed countries	1,909.3	912.8
Co-operation among developing countries	806.2	333.0
Consultation with Governments	<u>191.6</u>	<u>21.0</u>
TOTAL - RP	5,558.0	2,523.6
<b>B. INDUSTRIAL DEVELOPMENT DECADE FOR AFRICA (IDDA)</b>		
Projects identified through the integrated programme approach	<u>3,846.1</u>	<u>1,965.9</u>
TOTAL - IDDA	3,846.1	1,965.9

## APPENDIX D

## GEOGRAPHICAL DISTRIBUTION OF EXPERTS

(Listed in descending order)

Table 1

Appointments of experts, 1 January - 31 December 1990

Country/area/territory	Number of appointments	Country/area/territory	Number of appointments
France	226	Bolivia	7
United Kingdom	226	Morocco	7
United States of America	154	Sao Tome and Principe	7
Poland	139	Syrian Arab Republic	7
India	135	Togo	7
Germany	124	Haiti	6
Italy	84	Rwanda	6
Hungary	74	Tunisia	6
Canada	73	Uruguay	6
Austria	68	Bangladesh	5
Japan	48	Iran (Islamic Republic of)	5
Union of Soviet Socialist Republics	45	Nepal	5
Brazil	44	New Zealand	5
Czechoslovakia	43	Niger	5
Belgium	37	Pakistan	5
Denmark	36	Romania	5
Netherlands	35	Somalia	5
Philippines	35	United Republic of Tanzania	5
Yugoslavia	34	Côte d'Ivoire	4
Argentina	33	El Salvador	4
Peru	33	Ethiopia	4
Sweden	32	Honduras	4
Australia	27	Israel	4
Finland	27	Malawi	4
Spain	27	Cuba	3
Cameroon	26	Iraq	3
Nigeria	26	Mauritius	3
Egypt	24	Zimbabwe	3
Colombia	22	Burkina Faso	2
Mexico	22	Fiji	2
Zambia	22	Ghana	2
Costa Rica	21	Jamaica	2
Ecuador	20	Lebanon	2
Kenya	20	Mali	2
Norway	17	Mozambique	2
Venezuela	17	Saudi Arabia	2
Chile	16	Sierra Leone	2
Guinea	16	Solomon Islands	2
Algeria	15	Trinidad and Tobago	2
Ireland	15	Afghanistan	1
Sri Lanka	15	Angola	1
Guatemala	14	Botswana	1
Malaysia	14	Burundi	1
China	13	Congo	1
Sudan	12	Democratic People's Republic of Korea	1
Turkey	12	Djibouti	1
German Democratic Republic a/	11	Dominican Republic	1
Portugal	11	Jordan	1
Switzerland	11	Lesotho	1
Nicaragua	10	Luxembourg	1
Bulgaria	9	Madagascar	1
Senegal	9	Singapore	1
Thailand	9	Stateless	1
Indonesia	8	Viet Nam	1
Republic of Korea	8	Zaire	1
Uganda	8		
		TOTAL (111 countries)	2,490

a/ Through 2 October 1990.

Table 2

## Cumulative list of appointments of experts, 1986-1990

Country/area/territory	Number of appointments	Country/area/territory	Number of appointments
Poland	1,072	Malaysia	22
United Kingdom	1,018	Nicaragua	22
France	838	Uganda	21
United States of America	763	Guatemala	20
Germany	508	Iran (Islamic Republic of)	20
India	467	Sierra Leone	20
Italy	374	Uruguay	19
Hungary	328	Zimbabwe	19
Austria	291	Iraq	17
Belgium	215	Jamaica	16
Czechoslovakia	188	Ethiopia	13
Peru	182	Madagascar	13
Canada	179	El Salvador	12
Netherlands	173	Jordan	12
Brazil	172	Lebanon	11
Yugoslavia	162	Rwanda	11
Mexico	148	Syrian Arab Republic	11
Union of Soviet Socialist Republics	145	Botswana	10
Philippines	137	Cuba	10
Japan	135	Honduras	10
Sweden	135	United Republic of Tanzania	10
Denmark	129	Ghana	9
Spain	129	Malawi	9
Argentina	117	Niger	9
Egypt	117	Paraguay	9
Colombia	100	Mauritius	8
Australia	99	Burkina Faso	7
Chile	93	Sao Tome and Principe	7
Ireland	87	Trinidad and Tobago	7
Finland	82	Haiti	6
Venezuela	82	Benin	5
Cameroon	78	Fiji	5
Norway	71	Greece	5
Portugal	71	Stateless	5
German Democratic Republic a/	61	Democratic People's Republic of Korea	4
Sri Lanka	59	Mali	4
Ecuador	53	Mozambique	4
Bulgaria	52	Palestine	4
Nigeria	52	Panama	4
Switzerland	52	Saudi Arabia	4
Republic of Korea	51	Congo	3
Algeria	47	Dominican Republic	3
Côte d'Ivoire	43	Guyana	3
Zambia	35	Libyan Arab Jamahiriya	3
Bolivia	34	Singapore	3
Turkey	33	Angola	2
Costa Rica	31	Burundi	2
Indonesia	31	Chad	2
New Zealand	31	Djibouti	2
China	30	Liberia	2
Morocco	30	Papua New Guinea	2
Sudan	30	Solomon Islands	2
Togo	28	Viet Nam	2
Thailand	27	Afghanistan	1
Nepal	26	Antigua and Barbuda	1
Kenya	25	Barbados	1
Pakistan	25	Cape Verde	1
Somalia	25	Cyprus	1
Tunisia	25	Cambodia	1
Guinea	24	Gabon	1
Romania	24	Lesotho	1
Senegal	23	Luxembourg	1
Zaire	23	Mauritania	1
Bangladesh	22	Montserrat	1
Israel	22	Swaziland	1
		Yemen	1
		TOTAL (131 countries)	10,427

a/ Through 2 October 1990.

## APPENDIX E

## UNIDO INVOLVEMENT IN UNDP COUNTRY PROGRAMMES

Table 1

UNIDO share of UNDP country programmes approved by the Governing Council of UNDP,  
June 1985 to June 1990  
(By geographical area)

Geographical area	Number of countries for which programmes have been approved	Total IPF allocations	Total amount programmed (in millions of US\$)	Allocations for UNIDO projects	UNIDO share of amount programmed (percentage)	Number of projects	
						Ongoing	New
Africa	51	1,335.79	1,772.27	120.02	6.77	51	111
Arab States a/ (African Arab States) b/	19 (8)	248.91 (170.64)	416.69 (258.31)	37.05 (19.22)	8.89 (7.44)	14 (6)	53 (28)
Asia and the Pacific	31	1,094.64	1,002.44	222.06	22.15	72	162
Europe	10	47.04	42.15	13.13	31.15	10	45
Latin America and the Caribbean	<u>42</u>	<u>275.34</u>	<u>504.97</u>	<u>49.42</u>	9.79	<u>27</u>	<u>82</u>
TOTAL	145	2,831.08	3,480.21	422.46	12.14	168	425

a/ Includes African Arab States.

b/ Figures deducted since already included under both "Africa" and "Arab States".

Table 2

UNIDO share of UNDP country programmes approved by the Governing Council of UNDP,  
June 1985 to June 1990  
(By substantive branches of UNIDO)

UNIDO substantive branches	Number of projects		Value of UNDP input (\$000)	Percentage of total value	Distribution of projects by size		
	Ongoing	New			Under \$150,000	\$150,000 to \$1,000,000	Over \$1,000,000
Agro-based Industries	15	77	70,570	16.70	17	58	17
Chemical Industries	46	89	93,949	22.24	30	89	16
Metallurgical Industries	10	19	32,275	7.64	9	15	5
Engineering Industries	32	69	83,884	19.86	24	59	18
Industrial Planning	10	24	26,778	6.34	7	18	9
Institutional Infrastructure	21	72	62,803	14.87	19	68	15
Industrial Management and Rehabilitation	6	17	12,909	3.06	7	11	5
Industrial Human Resource Development	2	17	10,648	2.52	3	14	2
Feasibility Studies	15	24	21,374	5.06	7	27	5
Industrial Investment	1	11	4,340	1.03	3	9	0
Industrial Technology Development	1	0	61	0.01	1	0	0
Industrial Technology Promotion	0	3	1,070	0.25	0	3	0
Others	0	3	1,800	0.43	0	3	0
TOTAL	168	425	422,461	100.00	127	374	92

Table 3

Comparison of country programmes approved during June 1985 - June 1990 for the fourth cycle with programmes of the same countries in the third cycle (1982-1986) a/ (By geographical area)

Geographical area	Third cycle (1982-1986)				Fourth cycle (June 1985 - June 1990)			
	IPF	Amount programmed	Total value	Percentage share of amount programmed	IPF	Amount programmed	Total value	Percentage share of amount programmed
	(in millions of US\$)	(in millions of US\$)	(in millions of US\$)	(in %)	(in millions of US\$)	(in millions of US\$)	(in millions of US\$)	(in %)
Africa (50) b/	932.90	1,213.66	154.23	12.71	1,323.82	1,755.40	120.02	6.84
Arab States (18) d/	192.22	421.17	46.93	11.14	248.20	407.49	36.53	8.96
(African Arab States) (8) e/	(129.11)	(203.42)	(36.02)	(7.71)	(170.64)	(258.31)	(19.22)	(7.44)
Asia and the Pacific (30) f/	785.41	1,109.39	195.45	17.62	1,028.95	915.02	208.97	22.84
Europe (10) g/	39.72	66.42	16.11	24.25	47.04	42.15	13.13	31.15
Latin America and the Caribbean (38) c/	214.31	346.89	53.55	15.44	271.34	500.80	49.01	9.79
TOTAL (138)	2,035.45	2,954.11	430.25	14.56	2,748.71	3,362.55	408.44	12.15

a/ Excluded from the comparison are the following:

Africa: National liberation movements (first country programme in the fourth cycle).

Latin America and the Caribbean: Anguilla, Aruba, St. Helena (first country programme in the fourth cycle); Suriname (no country programme in the third cycle).

Arab States: Qatar (no country programme in the third cycle).

Asia and the Pacific: For Indonesia, because of the time-frame of the second (1979-1983) and third (1985-1989) country programmes which overlap the second, third and fourth programming cycles, it is difficult to make a comparison. The UNIDO share for Indonesia was 15.31 per cent in the second country programme and 14.97 per cent in the third country programme.

Europe: Czechoslovakia (no country programme in the fourth cycle).

b/ The 50 countries in Africa comprise: Algeria, Angola, Benin, Botswana, Burkina Faso, Burundi, Cameroon, Cape Verde, Central African Republic, Chad, Comoros, Congo, Côte d'Ivoire, Djibouti, Egypt, Equatorial Guinea, Ethiopia, Gabon, Gambia, Ghana, Guinea, Guinea-Bissau, Kenya, Lesotho, Liberia, Libyan Arab Jamahiriya, Madagascar, Malawi, Mali, Mauritania, Mauritius, Morocco, Mozambique, Niger, Nigeria, Rwanda, Sao Tome and Principe, Senegal, Seychelles, Sierra Leone, Somalia, Sudan, Swaziland, Togo, Tunisia, Uganda, United Republic of Tanzania, Zaire, Zambia and Zimbabwe.

c/ The 38 countries and territories in Latin America and the Caribbean comprise: Antigua and Barbuda, Argentina, Bahamas, Barbados, Belize, Bolivia, Brazil, British Virgin Islands, Eastern Caribbean States, Cayman Islands, Chile, Colombia, Costa Rica, Cuba, Dominica, Dominican Republic, Ecuador, El Salvador, Grenada, Guatemala, Guyana, Haiti, Honduras, Jamaica, Mexico, Montserrat, Netherlands Antilles, Nicaragua, Panama, Paraguay, Peru, Saint Lucia, Saint Kitts and Nevis, Saint Vincent and the Grenadines, Trinidad and Tobago, Turks and Caicos Islands, Uruguay and Venezuela.

d/ During most of the period concerned the 18 Arab States comprised: Algeria, Bahrain, Democratic Yemen, Djibouti, Egypt, Iraq, Jordan, Kuwait, Libyan Arab Jamahiriya, Morocco, Oman, Saudi Arabia, Somalia, Sudan, Syrian Arab Republic, Tunisia, United Arab Emirates and Yemen. Since the formation of Democratic Yemen and Yemen into one single sovereign State on 22 May 1990 the number of Arab States has been 17.

e/ The 8 African Arab States comprise: Algeria, Djibouti, Egypt, Libyan Arab Jamahiriya, Morocco, Somalia, Sudan and Tunisia (relevant figures are deducted since they are already included under both "Africa" and "Arab States").

f/ The 30 countries and territories in Asia and the Pacific comprise: Bangladesh, Bhutan, China, Cook Islands, Democratic People's Republic of Korea, Fiji, India, Islamic Republic of Iran, Kiribati, Lao People's Democratic Republic, Malaysia, Maldives, Mongolia, Myanmar, Nepal, Niue, Pakistan, Papua New Guinea, Philippines, Republic of Korea, Samoa, Singapore, Solomon Islands, Sri Lanka, Thailand, Tokelau, Tonga, Tuvalu, Vanuatu and Viet Nam.

g/ The 10 countries in Europe comprise: Albania, Bulgaria, Cyprus, Hungary, Malta, Poland, Portugal, Romania, Turkey and Yugoslavia.

## APPENDIX F

MAJOR STUDIES, REPORTS AND SERIES PUBLICATIONS  
ISSUED BY UNIDO IN 1990 <sup>a/</sup>

SYMBOL	TITLE	LANGUAGE
ID/SER.M/28*	Industry and development No. 28	E
ID/SER.O/1*	Planning and programming the introduction of CAD/CAM systems. A reference guide for developing countries	E
ID/355*	Guide to guarantee and warranty provisions in transfer-of-technology transactions	E
ID/358*	An international approach to biotechnology safety	E
ID/366 (ID/WG.488/5)	Consultation on the Food-Processing Industry with Emphasis on Fruit and Vegetable Processing. Tbilisi, Georgian Soviet Socialist Republic, USSR, 18-22 September 1989. Report	A C E F R S
ID/367 (ID/WG.491/7)	First Consultation on the Electronics Industry. Valletta, Malta, 6-10 November 1989. Report	A C E F R S
ID/368 (ID/WG.492/9)	First Consultation on Small- and Medium-Scale Enterprises including Co-operatives. Bari, Italy, 9-13 October 1989. Report	A C E F R S
ID/369* (UNIDO/LIB/SER.B/64)	Industrial Development Abstracts. UNIDO Industrial Information System (INDIS). 16001-16600	E (F R S introduction)
ID/370 (ID/WG.487/4)	Third Consultation on the Capital Goods Industry with Emphasis on Rural Transport Equipment. Vienna, Austria, 4-8 December 1989. Report	A C E F R S
ID/371*	Industry and development. Global report 1990/91	E F

<sup>a/</sup> Sales publications are indicated by an asterisk in the "Symbol" column.

## UNIDO TECHNICAL ASSISTANCE TO THE LEAST DEVELOPED COUNTRIES, 1 JANUARY TO 31 DECEMBER 1990

Table 1

## Delivery, by country and source of funds a/

(In US dollars)

Region/country	Regular budget XP/XA	UNDP/IPF	SIS	UNDP/special measures	IDF b/	Other sources c/	Total
<b>Africa</b>							
Benin	21,058	7,813	0	0	0	77,612	106,483
Botswana	149	29,461	20,662	0	247,612	0	297,884
Burkina Faso	71,127	509,844	0	0	0	0	580,971
Burundi	25,264	325,663	0	0	0	0	350,927
Cape Verde	145,925	27,653	12,928	0	14	0	186,520
Central African Republic	0	0	0	0	0	0	0
Chad	56,130	517,876	0	0	0	65,706	639,712
Comoros	0	0	0	0	0	21,237	21,237
Equatorial Guinea	0	0	0	0	0	0	0
Ethiopia	88,403	1,219,933	66,615	0	429,772	0	1,804,723
Gambia	0	23,669	0	0	0	0	23,669
Guinea	30,201	750,431	106,662	0	0	(1,914)	885,380
Guinea-Bissau	0	93,475	0	0	0	0	93,475
Lesotho	0	308,754	0	0	0	81,770	390,524
Malawi	0	1,799,362	38,086	0	245,931	68,680	2,152,059
Mali	385,082	229,481	(743)	0	76,428	3,500	693,748
Mauritania	0	222,055	0	0	0	0	222,055
Mozambique	0	682,134	29,067	0	235,403	63,651	1,010,255
Niger	96,240	326,742	33,174	0	48,059	0	504,215
Rwanda	0	938,121	0	0	0	61,243	999,364
Sao Tome and Principe	102,719	24,302	(850)	0	0	0	126,171
Sierra Leone	99,693	343,629	66,513	0	0	61,463	571,298
Togo	66,063	685,659	34,535	0	0	62,812	849,069
Uganda	0	98,475	159,938	0	0	713,836	972,249
United Republic of Tanzania	40,477	101,281	92,474	0	96,083	41,006	371,321
Subtotal	1,228,531	9,265,813	659,061	0	1,379,302	1,320,602	13,853,309
<b>Americas</b>							
Haiti	7,007	353,059	0	0	0	0	360,066

APPENDIX 6

Appendix 6

Table 1 (continued)

Region/country	Regular budget XP/XA	UNDP/IPF	SIS	UNDP/special measures	IDF b/	Other sources c/	Total
Arab States							
Djibouti	0	182,086	51,321	0	0	0	233,407
Somalia	0	770,759	(3,420)	0	89,879	0	857,218
Sudan	325,343	26,546	0	0	230,788	74,081	656,758
Yemen	11,412	1,517,891	(300)	159,645	29,292	50,998	1,768,938
Subtotal	336,755	2,497,282	47,601	159,645	349,959	125,079	3,516,321
Asia and the Pacific							
Afghanistan	0	118,667	12,427	0	14,632	0	145,726
Bangladesh	0	638,369	0	(812)	0	72,126	709,683
Bhutan	0	159,312	7,057	261,064	137,972	0	565,405
Kiribati	0	62,265	25,679	0	0	0	87,944
Lao People's Democratic Republic	0	(652)	0	0	0	0	(652)
Maldives	28,069	0	0	0	0	0	28,069
Myanmar	0	1,086,634	0	0	0	72,677	1,159,311
Nepal	72,614	1,140,974	38,445	0	33,344	3,935	1,289,312
Samoa	7,033	0	25,200	0	0	0	32,233
Tuvalu	0	14,662	0	0	0	0	14,662
Vanuatu	0	176,283	0	0	0	0	176,283
Subtotal	107,716	3,396,514	108,808	260,252	185,948	148,738	4,207,976
Regional, interregional and global projects especially designed for LDCs	90,900	0	0	0	19,752	0	110,652
TOTAL	1,770,909	15,512,668	815,470	419,897	1,934,961	1,594,419	22,048,324

a/ The table does not include regional, interregional and global projects or individual fellowships and group training programmes in which LDCs have been involved together with other developing countries; such activities are usually financed from non-least developed countries funds.

b/ Excluding 13 per cent overhead costs.

c/ Other sources include self-financed and other trust funds, World Bank/International Development Association, United Nations Capital Development Fund, United Nations Development Fund for Women, United Nations Financing System for Science and Technology for Development and United Nations Fund for Drug Abuse Control.



Table 2

## New project approvals, by country and source of funds a/

(In US dollars)

Region/country	Regular budget XP/XA	UNDP/IPF	SIS	UNDP/special measures	IDF b/	Other sources c/	Total
<b>Africa</b>							
Benin	23,100	39,000	0	0	0	124,700	186,800
Botswana	88,000	0	33,000	0	335,900	0	456,900
Burkina Faso	71,850	51,350	0	0	0	0	123,200
Burundi	62,604	143,950	0	0	0	8,850	215,404
Cape Verde	151,795	0	0	0	61,900	0	213,695
Central African Republic	0	0	0	0	0	0	0
Chad	80,000	0	0	0	0	76,786	156,786
Comoros	85,400	0	0	0	0	0	85,400
Equatorial Guinea	0	0	0	0	0	0	0
Ethiopia	333,755	689,100	84,000	0	0	0	1,106,855
Gambia	0	0	0	0	0	0	0
Guinea	236,620	0	0	0	0	3,500	240,120
Guinea-Bissau	0	0	0	0	0	40,000	40,000
Lesotho	8,544	0	43,000	0	0	0	51,544
Malawi	26,500	565,000	0	0	0	62,000	653,500
Mali	397,818	0	0	0	147,500	70,800	616,118
Mauritania	0	0	0	0	147,000	0	147,000
Mozambique	0	0	64,000	0	0	83,021	147,021
Niger	93,662	659,200	192,200	0	9,950	0	955,012
Rwanda	0	0	0	0	50,000	0	50,000
Sao Tome and Principe	116,522	0	0	0	0	0	116,522
Sierra Leone	115,900	0	0	0	0	0	115,900
Togo	128,468	3,063,830	79,100	0	0	0	3,271,398
Uganda	5,444	1,607,200	0	0	0	0	1,612,644
United Republic of Tanzania	128,733	109,100	0	0	0	43,300	281,133
Subtotal	2,154,715	6,927,730	495,300	0	752,250	512,957	10,842,952
<b>Americas</b>							
Haiti	6,336	56,000	0	0	30,000	0	92,336

Table 2 (continued)

Region/country	Regular budget XP/XA	UNDP/IPF	SIS	UNDP/special measures	IDF b/	Other sources c/	Total
Arab States							
Djibouti	28,575	0	49,540	0	0	0	78,115
Somalia	5,412	0	0	0	0	0	5,412
Sudan	408,881	0	0	0	0	86,490	495,371
Yemen	15,459	14,159	0	0	0	0	29,618
Subtotal	458,327	14,159	49,540	0	0	86,490	608,516
Asia and the Pacific							
Afghanistan	28,000	1,994,090	71,000	0	0	0	2,093,090
Bangladesh	0	301,000	0	0	0	0	301,000
Bhutan	19,300	0	148,800	0	0	0	168,100
Kiribati	0	0	0	0	0	0	0
Lao People's Democratic Republic	0	0	0	0	0	0	0
Maldives	29,000	0	0	0	0	0	29,000
Myanmar	0	396,950	0	0	0	160,500	557,450
Nepal	71,530	1,089,700	0	0	61,000	0	1,222,230
Samoa	103,894	0	0	0	0	0	103,894
Tuvalu	0	65,350	0	0	0	0	65,350
Vanuatu	0	0	0	0	0	0	0
Subtotal	251,724	3,847,090	219,800	0	61,000	160,500	4,540,114
Regional, interregional, and global projects especially designed for LDCs	224,930	0	0	0	371,470	0	596,400
TOTAL	3,096,032	10,844,979	764,640	0	1,214,720	759,947	16,680,318

a/ The table does not include regional, interregional and global projects or individual fellowships and group training programmes in which LDCs have been involved together with other developing countries; such activities are usually financed from non-least developed countries funds.

b/ Excluding 13 per cent overhead costs.

c/ Other sources include trust funds.

Table 3

Total project approvals (new projects, plus additional allocations to ongoing projects, minus cancellations), by country and source of funds a/

(In US dollars)

Region/country	Regular budget XP/XA	UNDP/IPF	SIS	UNDP/special measures	IDF b/	Other sources c/	Total
<b>Africa</b>							
Benin	23,100	58,381	0	0	0	124,700	206,181
Botswana	88,000	18,570	33,000	0	335,900	0	475,470
Burkina Faso	71,850	63,350	(8,858)	0	(3,185)	0	123,157
Burundi	62,604	2,430,932	(7,017)	0	(738)	8,850	2,494,631
Cape Verde	151,795	12,917	0	0	(87,148)	0	77,564
Central African Republic	0	0	0	0	0	0	0
Chad	80,000	415,327	0	0	0	76,786	572,113
Comoros	85,400	0	0	0	0	0	85,400
Equatorial Guinea	0	0	0	0	0	0	0
Ethiopia	333,755	881,568	18,200	0	1,962	0	1,235,485
Gambia	0	16,183	0	0	0	0	16,183
Guinea	236,620	(35,499)	31,622	0	0	3,500	236,243
Guinea-Bissau	0	0	(5,014)	0	0	40,000	34,986
Lesotho	8,544	527,106	43,000	0	0	48,924	627,574
Malawi	26,500	1,380,732	0	0	(23,000)	76,018	1,460,250
Mali	397,818	34,085	(6,023)	0	131,876	70,800	628,556
Mauritania	0	0	0	0	147,000	0	147,000
Mozambique	0	1,303,975	63,781	0	166,270	83,021	1,617,047
Niger	93,662	669,126	189,885	0	9,950	0	962,623
Rwanda	0	265,225	1,329	0	50,000	4,018	320,572
Sao Tome and Principe	116,522	23,239	(6,166)	0	0	0	133,595
Sierra Leone	115,900	954,112	(17,472)	0	(1,990)	0	1,050,550
Togo	128,468	3,074,896	58,599	0	0	0	3,261,963
Uganda	5,444	1,645,329	0	0	0	0	1,650,773
United Republic of Tanzania	128,733	794,679	18,971	0	(5,492)	43,300	980,191
Subtotal	2,154,715	14,534,233	407,837	0	721,405	579,917	18,398,107
<b>Americas</b>							
Haiti	6,336	600,003	0	0	30,000	0	636,339

Table 3 (continued)

Region/country	Regular budget XP/XA	UNDP/IPF	SIS	UNDP/special measures	IDF b/	Other sources c/	Total
<b>Arab States</b>							
Djibouti	28,575	42,294	49,540	0	0	0	120,409
Somalia	5,412	106,993	(21,390)	0	1,144	0	92,159
Sudan	408,881	0	0	0	(9,907)	87,092	486,066
Yemen	15,459	247,316	4,819	2,372	7,025	0	276,991
Subtotal	458,327	396,603	32,969	2,372	(1,738)	87,092	975,625
<b>Asia and the Pacific</b>							
Afghanistan	28,000	1,994,090	71,000	0	0	0	2,093,090
Bangladesh	0	292,510	0	23,142	0	0	315,652
Bhutan	19,300	684,522	149,513	153,400	0	0	1,006,735
Kiribati	0	3,792	(10,045)	0	0	0	(6,253)
Lao People's Democratic Republic	0	(8,122)	0	0	0	0	(8,122)
Maldives	29,000	0	0	0	0	0	29,000
Myanmar	0	460,963	0	0	0	(384,247)	76,716
Nepal	71,530	1,941,504	(3,675)	0	59,842	0	2,069,201
Samoa	103,894	0	8,188	0	0	0	112,082
Tuvalu	0	55,350	0	0	0	0	65,350
Vanuatu	0	0	0	0	0	0	0
Subtotal	251,724	5,434,609	214,981	176,542	59,842	(384,247)	5,753,451
Regional, interregional and global projects especially designed for LDCs	224,930	0	0	0	358,870	0	583,800
<b>TOTAL</b>	<b>3,096,032</b>	<b>20,965,448</b>	<b>655,787</b>	<b>178,914</b>	<b>1,168,379</b>	<b>282,762</b>	<b>26,347,322</b>

a/ The table does not include regional, interregional and global projects or individual fellowships and group training programmes in which LDCs have been involved together with other developing countries; such activities are usually financed from non-least developed countries funds.

b/ Excluding 13 per cent overhead costs.

c/ Other sources include trust funds, World Bank/International Development Association and United Nations Fund for Drug Abuse Control.

INDUSTRIAL DEVELOPMENT FUND

Table 1

UNIDF/IDF statement of pledges and receipts, as at 31 December 1990

(In US dollars)

Country/ organization	Unpaid balances/ advances by donors brought forward from UNIDF 1.1.86	Adjust- ments to prior pledges	IDF firm pledges for				Collections in		Exchange adjust- ments	Unpaid balance	Advances by donors
			1986- 1988	1989	1990	1991 and future years	1986- 1989	1990			
<b>General-purpose convertible</b>											
Afghanistan	1,500	0	3,000	0	0	0	4,500	0	0	0	0
Algeria	0	0	25,000	0	0	0	25,000	0	0	0	0
Angola	10,000	0	20,000	0	0	0	30,000	0	0	0	0
Argentina	0	150,000	0	0	0	0	149,990	0	10	0	0
Austria	0	0	209,533	76,336	155,039	0	301,189	181,818	(42,699)	0	0
Bahrain	5,000	0	0	0	0	0	5,000	0	0	0	0
Bangladesh	0	0	9,727	741	2,420	2,420	10,468	0	0	4,840	0
Barbados	0	0	20,000	0	0	0	20,000	0	0	0	0
Bhutan	1,320	0	1,450	0	0	0	2,770	0	0	0	0
Bolivia	2,000	0	16,313	1,000	0	0	14,313	0	0	5,000	0
Brazil	15,000	0	15,000	0	0	0	30,000	0	0	0	0
Burkina Faso	0	0	6,601	6,993	0	0	6,601	6,993	0	0	0
Cameroon	0	0	2,985	0	0	0	0	0	(999)	3,984	0
Chile	0	0	30,000	0	0	10,000	20,000	10,000	0	10,000	0
Colombia	1,425	40	17,100	5,837	5,772	0	24,402	5,772	0	0	0
Congo	11,426	0	0	0	0	0	3,400	0	76	7,950	0
Costa Rica	8,080	0	20,000	0	0	0	26,832	0	0	1,248	0
Cyprus	0	0	4,187	0	0	0	4,496	0	(309)	0	0
Czechoslovakia	0	0	0	0	40,501	0	0	40,501	0	0	0
Dominica	0	0	1,852	0	2,000	0	1,840	2,000	12	0	0
Ecuador	5,440	0	49,735	6,500	0	0	49,835	0	0	11,840	0
Egypt	0	0	2,000	0	0	0	2,000	0	0	0	0
Ethiopia	0	0	1,111	0	0	0	1,111	0	0	0	0
Fiji	0	0	1,009	0	0	0	0	0	229	780	0
German Democratic Republic	0	0	18,736	0	0	0	18,736	0	0	0	0
Ghana	0	0	5,000	0	0	0	0	0	0	5,000	0
Greece	36,000	0	0	0	0	0	36,000	0	0	0	0
Guatemala	0	0	37,422	0	0	0	5,000	0	6,123	26,299	0
Guinea	0	(108,600)	0	0	0	0	(108,600)	0	0	0	0
Guyana	723	509	2,227	1,063	126	42	3,874	126	646	44	0
Haiti	0	0	5,000	0	0	0	5,000	0	0	0	0
Honduras	0	0	8,000	7,000	0	0	8,000	6,000	630	370	0

APPENDIX H

Appendix H

Table 1 (continued)

Country/ organization	Unpaid balances/ advances by donors brought forward from UNIDF 1.1.86	Adjust- ments to prior pledges	IDF firm pledges for				Collections in		Exchange adjust- ments	Unpaid balance	Advances by donors
			1986- 1988	1989	1990	1991 and future years	1986- 1989	1990			
<b>General-purpose convertible (continued)</b>											
Hungary	0	0	5,976	18,519	19,839	22,400	22,060	18,661	3,613	22,400	0
India	500,000	0	750,000	250,000	250,000	0	1,250,000	500,000	0	0	0
Indonesia	0	0	50,000	0	0	0	50,000	0	0	0	0
Iraq	161,291	0	0	0	0	0	0	0	0	161,291	0
Italy	0	0	0	0	200,000	0	0	200,000	0	0	0
Jamaica	4,000	0	8,000	0	0	0	12,000	0	0	0	0
Kenya	10,000	0	27,639	0	1,674	1,409	0	10,348	7,748	22,626	0
Kuwait	0	0	150,000	0	0	0	0	0	0	150,000	0
Lao People's Democratic Republic	1,500	0	1,500	0	0	0	1,500	0	0	1,500	0
Lesotho	0	1,308	4,030	1,132	0	0	6,311	0	159	0	0
Luxembourg	0	0	27,484	10,256	10,127	12,821	40,004	11,429	(3,566)	12,821	0
Madagascar	0	0	3,865	669	0	715	2,879	669	986	715	0
Malawi	0	0	7,166	0	0	0	5,097	0	402	1,667	0
Malaysia	450	0	60,000	20,000	20,000	20,000	80,450	20,000	0	20,000	0
Mali	2,611	0	0	0	0	0	0	0	(1,373)	3,984	0
Malta	0	0	0	0	400	400	0	0	0	800	0
Mauritius	0	0	2,458	1,000	1,000	1,000	1,786	2,000	(47)	1,719	0
Mexico	0	4,503	15,000	0	0	0	19,503	0	0	0	0
Mongolia	0	0	7,152	2,450	2,450	1,312	9,696	2,450	(94)	1,312	0
Morocco	5,038	5,010	5,000	0	0	0	13,421	0	1,627	0	0
Mozambique	4,925	0	5,063	0	0	0	5,563	0	4,425	0	0
Myanmar	0	0	3,000	0	0	1,000	3,000	0	0	1,000	0
Nepal	0	0	1,400	700	700	0	2,100	700	0	0	0
Netherlands	0	0	0	0	657,895	0	0	372,079	(6,582)	292,398	0
Nigeria	50,000	0	0	0	0	0	0	0	0	50,000	0
Oman	12,000	0	12,000	0	0	0	12,000	0	0	12,000	0
Pakistan	0	0	48,933	0	0	0	48,933	0	0	0	0
Panama	0	0	4,000	2,000	0	0	2,000	0	0	4,000	0
Papua New Guinea	0	0	12,871	0	0	0	14,773	0	(1,902)	0	0
Paraguay	30,000	0	0	0	0	0	24,000	0	0	6,000	0
Peru	25,000	0	0	0	0	0	5,000	0	0	20,000	0
Philippines	6,006	0	15,000	5,000	0	0	7,608	6,930	0	11,468	0
Portugal	0	0	30,000	0	0	0	30,000	0	0	0	0
Republic of Korea	0	0	86,000	35,000	35,000	35,000	121,000	35,000	0	35,000	0
Rwanda	0	0	12,000	4,000	4,000	0	12,000	8,000	0	0	0
Saint Vincent and the Grenadines	0	0	0	1,500	0	0	1,500	0	0	0	0
Saudi Arabia	0	0	2,000,000	1,000,000	0	0	2,000,000	1,000,000	0	0	0
Senegal	29,113	0	4,000	0	0	0	20,900	0	0	12,213	0

Table 1 (continued)

Country/ organization	Unpaid balances/ advances by donors brought forward from UNIDF 1.1.86	Adjust- ments to prior pledges	IDF firm pledges for				Collections in		Exchange adjust- ments	Unpaid balance	Advances by donors
			1986- 1988	1989	1990	1991 and future years	1986- 1989	1990			
<b>General-purpose convertible (continued)</b>											
Sierra Leone	94	3,184	5,891	0	0	0	9,167	0	2	0	0
Somalia	2,467	0	0	0	0	0	0	0	67	2,400	0
Sri Lanka	0	0	9,333	3,333	3,333	3,333	12,630	3,333	36	3,333	0
Sudan	102,712	0	0	0	0	0	0	0	0	102,712	0
Suriname	2,000	0	0	0	0	0	0	0	0	2,000	0
Swaziland	1,532	1,802	5,541	1,606	1,444	0	9,387	1,544	(556)	1,550	0
Syrian Arab Republic	0	5,372	6,168	1,871	1,871	0	13,411	1,871	0	0	0
Thailand	0	0	61,332	20,598	21,032	24,206	82,469	21,032	(539)	24,206	0
Togo	3,916	0	4,655	1,859	0	0	9,153	193	(908)	1,992	0
Trinidad and Tobago	0	8,375	26,800	23,529	47,858	0	60,379	47,858	(1,675)	0	0
Tunisia	0	0	69,927	22,102	0	0	89,342	0	2,687	0	0
Uganda	1,000	1,000	9,000	0	0	0	2,000	0	0	9,000	0
United Republic of Tanzania	0	0	2,694	714	414	332	2,514	392	855	393	0
Venezuela	0	0	11,467	0	0	0	11,467	0	0	0	0
Viet Nam	1,000	0	0	0	0	0	1,000	0	0	0	0
Yemen	0	0	4,400	2,000	2,000	0	0	4,007	(7)	4,400	0
Zaire	3,000	0	103,000	10,000	0	0	0	0	0	116,000	0
Zambia	517	0	11,756	5,089	2,985	1,136	12,061	5,033	2,958	1,431	0
Zimbabwe	0	8,075	29,175	0	10,272	0	34,749	10,272	2,501	0	0
<b>Organizations</b>											
King Abdulaziz City for Science and Technology, Saudi Arabia	0	0	32,760	0	0	0	29,868	0	0	2,892	0
S.G.des Eaux Minerales de Vittel, France	0	0	3,108	0	0	0	3,108	0	0	0	0
Computech Engineering Services Inc., USA	0	0	30,000	0	0	0	30,000	0	0	0	0
Cooperation Council for the Arab States of the Gulf (GCC)	0	0	11,587	0	0	0	0	0	0	11,587	0
<b>Total</b>	<b>1,058,086</b>	<b>80,578</b>	<b>4,331,119</b>	<b>1,550,397</b>	<b>1,500,152</b>	<b>137,526</b>	<b>4,939,546</b>	<b>2,537,011</b>	<b>(24,864)</b>	<b>1,206,165</b>	<b>0</b>





Table 1 (continued)

Country/ organization	Unpaid balances/ advances by donors brought forward from UNIDF 1.1.86	Adjust- ments to prior pledges	IDF firm pledges for			Collections in		Exchange adjust- ments	Unpaid balance	Advances by donors	
			1986- 1988	1989	1990	1991 and future years	1986- 1989				1990
<b>Special-purpose convertible (continued)</b>											
Arab Industrial Development Organization	(19,877)	0	0	(123)	87,120	0	(20,000)	0	0	37,120	0
African Institute for Higher Technology Training and Research, Kenya	1,253	0	(5,564)	0	0	0	(4,311)	0	0	0	0
Banque Ouest Africaine de developpement (BOAD), Togo	0	0	2,828	(28)	0	0	2,800	0	0	0	0
Chiyoda Corporation	0	0	0	0	121,701	0	0	126,368	0	0	(4,667)
Corporacion Andina de Fomento (CAF)	0	0	0	0	275,635	294,365	0	570,000	0	0	0
Egyptian Iron and Steel Co.	(10,576)	0	5,863	0	0	0	0	0	0	0	(4,713)
Kuwait Institute for Higher Technical Training and Research	(48,229)	0	74,665	0	0	0	0	0	0	26,436	0
S.G. des Eaux Minerales de Vittel, Franch	0	0	21,846	0	8,044	0	33,715	0	0	0	(3,825)
Nobel Chematur, Sweden	0	0	9,040	0	0	0	9,040	0	0	0	0
Apple Computer, USA	0	0	22,549	4,982	0	0	33,900	0	0	0	(6,369)
Cordecruz, Bolivia	0	0	0	0	0	0	22,017	0	0	0	(22,017)
Saudi Consulting House, Saudi Arabia	0	0	0	11,299	113	0	12,000	0	0	0	(588)
<b>Total</b>	<b>(6,887,229)</b>		<b>39,624,862</b>	<b>21,494,944</b>	<b>38,003,177</b>	<b>29,380,044</b>	<b>79,660,921</b>	<b>23,050,467</b>	<b>0</b>	<b>25,763,165</b>	<b>(6,858,755)</b>
<b>Non-convertible</b>											
Bulgaria	(222,203)	0	359,116	50,512	57,100	0	379,463	57,613	0	0	(192,551)
China	(54,661)	0	299,487	195,188	(11,416)	0	450,135	89,172	0	0	(110,709)
Cuba	(219,864)	0	210,969	43,027	77,389	0	108,479	28,000	0	0	(24,958)
Czechoslovakia	(78)	0	1,033,726	412,192	248,030	235,295	1,462,923	267,328	0	198,914	0
Egypt	21,793	0	49,894	(15,000)	0	0	72,492	0	0	0	(15,805)
German Democratic Republic	(282,596)	0	1,283,363	539,972	1,147,271	0	2,364,737	698,824	0	0	(375,551)
Hungary	(1,360)	0	454,845	37,045	149,616	0	526,163	178,548	0	0	(64,565)
India	(399,558)	0	111,536	100,330	270,713	200,900	1,486,305	1,002,315	0	0	(2,204,699)
Mongolia	(15,925)	0	0	0	0	0	0	0	0	0	(15,925)
Pakistan	(98,888)	0	68,098	7,341	8,064	3,792	69,195	6,849	0	0	(87,637)
Poland	(26,495)	0	717,004	59,859	90,198	95,500	827,788	96,963	0	11,315	0

Table 1 (continued)

Country/ organization	Unpaid balances/ advances by donors brought forward from UNIDF 1.1.86	Adjust- ments to prior pledges	IDF firm pledges for				Collections in		Exchange adjust- ments	Unpaid balance	Advances by donors
			1986- 1988	1989	1990	1991 and future years	1986- 1989	1990			
<b>Non-convertible (continued)</b>											
Romania	(2,471)	0	61,991	88,913	(26,763)	80,801	141,671	47,557	0	13,243	0
Turkey	(2,258)	0	497,914	159,920	185,729	0	847,198	157,058	0	0	(162,951)
USSR	(402,605)	0	3,200,867	705,107	1,141,501	19,869	3,904,021	1,067,324	0	0	(306,606)
Yugoslavia	(57,228)	0	171,375	89,607	131,997	4,700	505,637	198,182	0	0	(363,368)
<b>Organizations</b>											
Egyptian Iron and Steel Co.	(26,747)	0	(5,195)	0	0	0	0	0	0	0	(31,942)
<b>Total non-convertible</b>	<b>(1,791,144)</b>	<b>0</b>	<b>8,514,990</b>	<b>2,474,013</b>	<b>3,469,429</b>	<b>640,857</b>	<b>13,146,207</b>	<b>3,895,733</b>	<b>0</b>	<b>223,472</b>	<b>(3,957,267)</b>
<b>GRAND TOTAL</b>	<b>(7,620,287)</b>	<b>80,578</b>	<b>52,470,971</b>	<b>25,519,354</b>	<b>42,972,758</b>	<b>30,158,427</b>	<b>97,746,674</b>	<b>29,483,211</b>	<b>(24,864)</b>	<b>27,192,802</b>	<b>(10,816,022)</b>

Table 2

## Status of resources of the Industrial Development Fund as at 31 December 1990

(In thousands of US dollars)

	Convertible		Non-convertible	Total
	General-purpose	Special-purpose		
<b>Available for programming</b>				
Balance from UNIDF	4,562	0	0	4,562
Pledges, 1986/1991	7,600	121,907	20,097	149,604
Revaluation of pledges	25	13,372	(3,373)	10,024
Interest income	4,126	0	0	4,126
Other income	78	0	0	78
<b>TOTAL AVAILABLE</b>	<b>16,391</b>	<b>135,279</b>	<b>16,724</b>	<b>168,394</b>
<b>Approvals</b>				
<b>Projects</b>				
Expenditure, 1986/1990	9,514	77,695	13,412	100,621
Commitments, 1991 and future	77	5,007	289	5,373
Not yet implemented	2,113	31,644	1,398	35,155
Subtotal	11,704	114,346	15,099	141,149
<b>Support costs, 1986/1990</b>				
General-purpose convertible	1,203	0	0	1,203
Special-purpose convertible	35	9,594	0	9,629
Non-convertible a/	1,657	67	0	1,724
Subtotal	2,895	9,661	0	12,556
<b>Reserve for support costs, 1991 and future</b>				
General-purpose convertible	285	0	0	285
Special-purpose convertible	0	4,765	0	4,765
Non-convertible a/	219	0	0	219
Subtotal	504	4,765	0	5,269
<b>TOTAL APPROVALS</b>	<b>15,103</b>	<b>128,772</b>	<b>15,099</b>	<b>158,974</b>
<b>PROGRAMMABLE BALANCE</b>	<b>1,288</b>	<b>6,507</b>	<b>1,625</b>	<b>9,420</b>
<b>Cash position</b>				
Balance from UNIDF	5,229	9,524	3,375	18,128
Contributions received	7,464	102,711	17,042	127,217
Interest and other income	4,204	15,665	(2,486)	17,383
Subtotal	16,897	127,900	17,931	162,728
Disbursements, 1986/1990 (including support costs)	12,820	81,394	13,273	107,487
<b>CASH BALANCE</b>	<b>4,077</b>	<b>46,506</b>	<b>4,658</b>	<b>55,241</b>
<b>Unliquidated obligations, 1990 and prior</b>				
Commitments, 1991 and future	757	8,600	1,723	11,080
Reserve for support costs, 1991 and future	77	5,007	289	5,373
Residual value of projects	504	4,765	0	5,269
	2,113	31,644	1,398	35,155
<b>TOTAL COMMITMENTS</b>	<b>3,451</b>	<b>50,016</b>	<b>3,410</b>	<b>56,877</b>
<b>UNCOMMITTED CASH BALANCE</b>	<b>626 b/</b>	<b>(3,510)</b>	<b>1,248</b>	<b>(1,636)</b>

a/ Support costs for projects financed from non-convertible currencies are normally charged to the general convertible segment. However, some donors have agreed that support costs on such projects financed by them should be charged to their convertible contributions.

b/ Against which has been established the operational reserve totalling \$0.550 million.

**Table 3**  
Cumulative list of projects approved for financing under UNIDF/IDF, 1978-1990,  
classified according to priority area, as at 31 December 1990

UNIDF/IDF priority area	Number of projects	Special-purpose convertible	General-purpose convertible	Special-purpose non-convertible	General-purpose non-convertible	Total (in US dollars)	Percentage
		(in US dollars, excluding overheads)					
Special measures for the least developed, land-locked and island developing countries	142	9,220,486	3,186,741	292,409	1,601,959	14,301,595	6.3
Development and transfer of industrial technology and industrial information	463	45,279,620	8,012,732	962,901	1,458,819	55,714,072	24.7
Economic co-operation among developing countries	126	954,177	3,830,342	37,649	1,343,981	6,166,149	2.7
Training programmes and strengthening industrial training institutions in developing countries	826	25,797,215	5,261,841	6,183,225	15,644,446	52,886,727	23.4
Industrial institutional infrastructure	116	6,665,092	2,793,706	252,212	422,293	10,133,503	4.5
Industries processing local natural resources, including export-oriented industries	154	14,273,770	2,294,089	330,150	518,365	17,416,374	7.7
Industries satisfying basic needs and support to rural industries	92	6,230,853	1,807,502	279,822	95,559	8,413,736	3.7
Promotional activities	315	49,162,072	5,317,047	1,095,483	947,782	56,522,384	25.0
Other activities	62	1,786,179	2,363,159	271,902	11,594	4,432,834	2.0
<b>TOTAL</b>	<b>2,296</b>	<b>159,369,464</b>	<b>34,867,159</b>	<b>9,705,753</b>	<b>22,044,998</b>	<b>225,987,374</b>	<b>100.0</b>

Table 4

Breakdown of all new projects financed under IDf in 1990  
(UC, US, UT and UD)

(By region and programme component)

Region	US\$	Percentage
Africa (excluding Arab States)	3,134,698	10.1
Arab States	938,030	3.1
African	330,500	1.1
West Asian	93,200	0.3
Regional	514,330	1.7
Asia and the Pacific	4,247,707	13.7
Europe	72,689	0.2
Latin America and the Caribbean	2,700,023	8.7
Global and Interregional	19,890,409	64.2
TOTAL	30,983,556	100.0
<u>Programme component/priority area</u>		
Special measures for the least developed, land-locked and island developing countries	878,820	2.8
Development and transfer of industrial technology and industrial information	9,297,710	30.0
Economic co-operation among developing countries	188,679	0.6
Training programmes and strengthening industrial training institutions in developing countries	6,461,419	20.9
Industrial institutional infrastructure	2,112,500	6.8
Industries processing local natural resources, including export-oriented industries	858,849	2.8
Industries satisfying basic needs and support to rural industries	541,900	1.7
Promotional activities	9,620,603	31.1
Others	1,023,076	3.3
TOTAL	30,983,556	100.0

Table 4 (a)  
General-purpose convertible projects (UC)  
 (By region and programme component)

Region	US\$	Percentage
Africa (excluding Arab States)	246,750	12.8
Arab States	408,730	21.3
African	146,500	7.6
West Asian	45,900	2.4
Regional	216,330	11.2
Asia and the Pacific	248,908	12.9
Europe	42,668	2.2
Latin America and the Caribbean	475,998	24.8
Global and Interregional	500,510	26.0
TOTAL	1,923,564	100.0
<u>Programme component/priority area</u>		
Special measures for the least developed, land-locked and island developing countries	162,950	8.5
Development and transfer of industrial technology and industrial information	495,056	25.7
Economic co-operation among developing countries	47,877	2.5
Training programmes and strengthening industrial training institutions in developing countries	232,211	12.1
Industrial institutional infrastructure	123,500	6.4
Industries processing local natural resources, including export-oriented industries	88,000	4.6
Industries satisfying basic needs and support to rural industries	25,000	1.3
Promotional activities	748,970	38.9
Others	0	
TOTAL	1,923,564	100.0

Table 4 (b)  
Special-purpose convertible projects (US)  
 (By region and programme component)

Region	US\$	Percentage
Africa (excluding Arab States)	2,887,948	11.2
Arab States	499,300	2.0
African	154,000	0.6
West Asian	47,300	0.2
Regional	298,000	1.2
Asia and the Pacific	3,558,060	13.8
Europe	0	
Latin America and the Caribbean	2,211,525	8.6
Global and Interregional	16,583,975	64.4
TOTAL	25,740,808	100.0
<u>Programme component/priority area</u>		
Special measures for the least developed, land-locked and island developing countries	715,870	2.8
Development and transfer of industrial technology and industrial information	8,482,790	33.0
Economic co-operation among developing countries	58,364	0.2
Training programmes and strengthening industrial training institutions in developing countries	4,117,334	16.0
Industrial institutional infrastructure	1,989,000	7.7
Industries processing local natural resources, including export-oriented industries	440,699	1.7
Industries satisfying basic needs and support to rural industries	516,900	2.0
Promotional activities	8,396,775	32.6
Others	1,023,076	4.0
TOTAL	25,740,808	100.0

Table 4 (c)

Special-purpose and general-purpose non-convertible projects (UD/UT)

(By region and programme component)

Region	US\$	Percentage
Africa (excluding Arab States)	0	
Arab States	30,000	0.9
African	30,000	0.9
West Asian	0	
Regional	0	
Asia and the Pacific	440,739	13.3
Europe	30,021	0.9
Latin America and the Caribbean	12,500	0.4
Global and Interregional	2,805,924	84.5
	<hr/>	<hr/>
TOTAL	3,319,184	100.0
 <u>Programme component/priority area</u>		
Special measures for the least developed, land-locked and island developing countries	0	
Development and transfer of industrial technology and industrial information	319,864	9.6
Economic co-operation among developing countries	82,438	2.5
Training programmes and strengthening industrial training institutions in developing countries	2,111,874	63.6
Industrial institutional infrastructure	0	
Industries processing local natural resources, including export-oriented industries	330,150	10.0
Industries satisfying basic needs and support to rural industries	0	
Promotional activities	474,858	14.3
Others	0	
	<hr/>	<hr/>
TOTAL	3,319,184	100.0



TRAINING ACTIVITIES IN 1990

Table 1 a/

In-plant group training programmes in 1990

Field of study	<u>Type of programme</u>				<u>Number of participants</u>			
	National	Regional	Inter- regional	Host country	of which			
					All developing countries	LDCs	Female	African participants b/
Man-made fibres	-	-	x	Austria	16	4	1	7
Plastics technology	-	-	x	Austria	12	4	1	5
Diesel engines	-	-	x	China	15	6	0	5
Maintenance - refrigeration equipment	-	x	-	France	20	0	3	0
Maintenance - biomedical electronic equipment	-	-	x	Hungary	12	3	1	3
Maintenance - gas/oil transportation network	-	-	x	Hungary	12	1	0	4
Production management	-	-	x	Japan	15	1	1	0
Manufacturing and assembly of sprayguns	-	x	-	Poland	2	0	0	2
Design and manufacture of cast spare parts	-	-	x	Poland	5	2	0	3
Cement industry	-	-	x	Turkey	9	4	1	2
Sugar industry	-	-	x	Turkey	9	3	2	3
Fruit and vegetable processing	-	-	x	Turkey	9	5	1	8
Iron and steel industry	-	-	x	Turkey	12	3	0	6
Utilization of medicinal and aromatic plants in pharmaceutical industry	-	-	x	Turkey	8	4	2	5
Small-scale foundry industry	-	x	-	Turkey	8	5	0	8
Maintenance - railway track	-	x	-	United Kingdom/ Egypt	14	6	0	14
Maintenance - rolling stock	-	x	-	United Kingdom/ Malawi	15	6	0	15
Clean technology: application and transfer	-	-	x	USA	13	0	0	1
Rice processing	-	-	x	USSR	12	2	0	2

APPENDIX I

Appendix I

Table 1 a/ (continued)

Field of study	Type of programme				Number of participants			
	National	Regional	Inter- regional	Host country	of which			
					All developing countries	LDCs	Female	African participants b/
Maintenance - machine tools	-	-	x	USSR	14	3	0	9
Metalworking industry	-	-	x	USSR	13	0	2	0
Electric welding c/	-	-	x	USSR	25	8	2	9
Mineral fertilizer industry	-	-	x	USSR	15	1	1	7
Wheat milling	-	-	x	USSR	15	6	0	6
Industrial information	-	-	x	USSR	14	4	5	7
Iron and steel c/	-	-	x	USSR	31	10	0	7
Maintenance - iron and steel	-	x	-	Zimbabwe	15	4	0	15
TOTAL					360	95	23	153

a/ These figures do not include participants in training activities organized within the framework of UNIDO-executed field projects.

b/ Including participants from African Arab States.

c/ Two programmes carried out in 1990.

TRAINING ACTIVITIES IN 1990

Table 2 a/

Other group training programmes in 1990

Field of study	Type of programme				Number of participants			
	National	Regional	Inter-regional	Host country	of which			
					All developing countries	LDCs	Female	African participants b/
Financial/economic analysis and COMFAR application	x	-	-	Albania	16	0	3	0
Quality control	-	x	-	Algeria	17	0	4	17
Financial/economic analysis and COMFAR application c/ d/	-	-	x	Austria	14	3	4	3
Financial/economic analysis and COMFAR application for Nigerian Bankers d/	x	-	-	Austria	15	0	3	15
Computer-aided tools/ spare parts production	-	x	-	Belgium	12	0	1	0
Technology transfer negotiation	x	-	-	Cape Verde	25	0	4	25
Financial/economic analysis and COMFAR application d/	-	x	-	Central African Republic	12	0	0	12
Fly-ash utilization	-	-	x	China	19	2	6	1
Project preparation and evaluation	x	-	-	China	60	0	18	0
Financial/economic analysis and COMFAR application	x	-	-	Cuba	27	0	9	0
Flexible automation implementation in engineering and metallurgical production	-	-	x	Czechoslovakia	12	1	0	4
Testing in heavy power electrical engineering	-	-	x	Czechoslovakia	14	1	2	2
PC CAD/CAM applications in basic engineering industries with emphasis on maintenance and repair	-	-	x	Czechoslovakia	12	3	1	6

Table 2 a/ (continued)

Field of study	Type of programme			Host country	Number of participants			
	National	Regional	Inter- regional		of which			
					All developing countries	LDCs	Female	African participants b/
Technology transfer contracting and negotiation	-	x	-	Egypt	67	0	5	67
Environmental management	-	x	-	Finland/USSR	26	4	4	0
Financial/economic analysis and COMFAR application	-	-	x	France	18	9	1	15
Computing services and software in industry	-	x	-	France	18	2	1	0
Printing industry	-	-	x	Germany	18	5	1	6
Industrial planning	-	-	x	Germany	22	8	4	8
Financial/economic analysis and COMFAR application	x	-	-	Guinea	16	16	1	16
Project preparation and evaluation/COMFAR	x	-	-	Haiti	30	30	6	0
National instrumentation policies with special emphasis on repair and maintenance	-	-	x	Hungary	13	1	1	4
Cement technology c/	-	-	x	India	28	0	0	17
Training of trainers - development finance institutes	-	x	-	Italy	18	10	4	18
Project preparation, evaluation and financing	-	x	-	Italy	13	9	1	13
Analysis/evaluation of investment feasibility studies c/ d/	-	-	x	Italy	37	5	8	10
Maintenance plant inspection and energy conservation in petroleum refineries	-	-	x	Japan	21	0	0	5
Industrial planning	-	x	-	Japan	7	0	3	0
Financial/economic analysis and COMFAR application	x	-	-	Malaysia	17	0	0	0
Financial/economic analysis and COMFAR application	x	-	-	Malta	23	0	4	0
Financial/economic analysis and COMFAR application	x	-	-	Morocco	8	0	2	8

Table 2 a/ (continued)

Field of study	Type of programme				Number of participants			
	National	Regional	Inter-regional	Host country	of which			
					All developing countries	LDCs	Female	African participants b/
Management of building materials production	-	x	-	Morocco	55	0	4	55
Financial/economic analysis and COMFAR application	x	-	-	Nicaragua	13	0	3	0
Project preparation and evaluation (advanced)	-	-	x	Poland	18	5	4	4
Railway transport development	-	-	x	Switzerland	19	2	0	4
Cement industry	-	-	x	Turkey	10	2	0	4
Cement technology c/	-	-	x	Turkey	30	0	0	21
Research and development in petrochemical industries	-	-	x	Turkey	8	0	1	6
Management of human resources	-	-	x	USSR	13	4	3	5
Welding and chlorine processing of titanium rich slags	-	-	x	USSR	14	2	2	6
Electro-smelting of ilmenite concentrates and chlorine processing of titanium rich slags	-	-	x	USSR	11	0	1	2
Financial/economic analysis and COMFAR application	x	-	-	Yemen	11	11	2	0
Project preparation, evaluation and financing	x	-	-	Yugoslavia	21	0	4	0
TOTAL					878	135	125	379

a/ These figures do not include participants in training activities organized within the framework of UNIDO-executed field projects.

b/ Including participants from African Arab States.

c/ Two programmes carried out in 1990.

d/ Self-financed seminars (by participants or recipient institution).

**Table 3**  
**Number of fellowships and study tours started in 1990,**  
**by nationality/home area, country or territory**

Nationality/home area, country or territory	Number of individuals placed									Total
	UNDP			Regular programme			Other programmes			
	Male	Female	Total	Male	Female	Total	Male	Female	Total	
<b>AFRICA a/</b>										
Angola	9	1	10	0	0	0	0	0	0	10
Botswana	0	0	0	1	0	1	0	1	1	2
Burkina Faso	5	1	6	3	1	4	0	0	0	10
Cameroon	0	0	0	1	0	1	2	0	2	3
Congo	1	0	1	0	0	0	2	0	2	3
Côte d'Ivoire	1	0	1	0	0	0	0	0	0	1
Ethiopia	21	2	23	1	0	1	16	0	16	40
Ghana	6	2	8	0	0	0	0	0	0	8
Guinea	3	0	3	0	0	0	0	0	0	3
Kenya	7	0	7	2	0	2	1	1	2	11
Lesotho	4	0	4	0	0	0	0	0	0	4
Liberia	0	0	0	1	0	1	0	0	0	1
Madagascar	17	3	20	0	0	0	0	0	0	20
Malawi	21	5	26	0	0	0	0	0	0	26
Mauritius	1	0	1	0	0	0	0	0	0	1
Mozambique	3	1	4	0	0	0	0	0	0	4
Niger	2	2	4	1	0	1	0	0	0	5
Nigeria	18	1	19	1	0	1	1	0	1	21
Rwanda	7	0	7	0	0	0	1	0	1	8
Senegal	0	0	0	1	0	1	0	0	0	1
Seychelles	0	1	1	0	0	0	1	0	1	2
Sierra Leone	0	0	0	1	0	1	0	0	0	1
Togo	7	0	7	0	0	0	0	0	0	7
Uganda	0	0	0	0	0	0	6	0	6	6
United Republic of Tanzania	11	0	11	0	0	0	1	0	1	12
Zambia	7	0	7	0	0	0	1	1	2	9
Zimbabwe	3	0	3	2	0	2	2	0	2	7
<b>Total Africa</b>	<b>154</b>	<b>19</b>	<b>173</b>	<b>15</b>	<b>1</b>	<b>16</b>	<b>34</b>	<b>3</b>	<b>37</b>	<b>226</b>
<b>ARAB STATES</b>										
Algeria	64	8	72	0	0	0	3	0	3	75
Egypt	18	5	23	0	0	0	13	0	13	36
Iraq	5	4	9	0	0	0	4	0	4	13
Jordan	0	0	0	0	0	0	3	1	4	4
Libyan Arab Jamahiriya	0	0	0	0	0	0	7	0	7	7
Morocco	16	1	17	0	0	0	11	0	11	28
Oman	0	0	0	0	0	0	3	0	3	3
Qatar	0	0	0	0	0	0	2	0	2	2
Saudi Arabia	3	0	3	0	0	0	0	0	0	3
Sudan	0	0	0	3	0	3	5	0	5	8
Syrian Arab Republic	29	1	30	0	0	0	3	0	3	33
Tunisia	20	1	21	0	0	0	10	0	10	31
United Arab Emirates	0	0	0	0	0	0	1	0	1	1
Yemen	23	1	24	0	0	0	1	0	1	25
<b>Total Arab States</b>	<b>178</b>	<b>21</b>	<b>199</b>	<b>3</b>	<b>0</b>	<b>3</b>	<b>66</b>	<b>1</b>	<b>67</b>	<b>269</b>

Table 3 (continued)

Nationality/home area, country or territory	Number of individuals placed									
	UNDP			Regular programme			Other programmes			Total
	Male	Female	Total	Male	Female	Total	Male	Female	Total	
<b>ASIA AND THE PACIFIC</b>										
Bangladesh	3	0	3	0	0	0	2	0	2	5
Bhutan	4	0	4	0	0	0	7	0	7	11
China	127	26	153	0	0	0	39	7	46	199
Democratic People's Republic of Korea	17	2	19	0	0	0	0	0	0	19
Fiji	1	2	3	0	0	0	0	0	0	3
India	91	4	95	0	0	0	25	1	26	121
Indonesia	12	2	14	0	0	0	1	0	1	15
Iran (Islamic Republic of)	13	0	13	0	0	0	5	0	5	18
Malaysia	3	0	3	0	0	0	0	0	0	3
Mongolia	26	9	35	1	0	1	1	0	1	37
Myanmar	0	0	0	0	0	0	4	0	4	4
Nepal	27	1	28	1	0	1	0	0	0	29
Pakistan	17	0	17	0	0	0	1	0	1	18
Papua New Guinea	4	1	5	0	0	0	0	0	0	5
Philippines	13	19	32	3	0	3	5	1	6	41
Republic of Korea	17	1	18	0	0	0	0	0	0	18
Singapore	1	0	1	0	0	0	0	0	0	1
Sri Lanka	47	10	57	0	0	0	2	1	3	60
Thailand	3	4	7	0	0	0	0	0	0	7
Tuvalu	1	0	1	0	0	0	0	0	0	1
Viet Nam	171	54	225	2	1	3	1	0	1	229
<b>Total Asia and the Pacific</b>	<b>598</b>	<b>135</b>	<b>733</b>	<b>7</b>	<b>1</b>	<b>8</b>	<b>93</b>	<b>10</b>	<b>103</b>	<b>844</b>
<b>EUROPE</b>										
Albania	41	5	46	0	0	0	3	0	3	49
Bulgaria	99	11	110	0	0	0	2	1	3	113
Byelorussian SSR	1	0	1	0	0	0	0	0	0	1
Cyprus	9	3	12	0	0	0	0	0	0	12
Czechoslovakia	9	2	11	0	0	0	2	0	2	13
Hungary	48	4	52	0	0	0	7	4	11	63
Malta	6	0	6	0	0	0	0	0	0	6
Poland	40	5	45	1	0	1	2	0	2	48
Portugal	4	0	4	0	0	0	2	0	2	6
Romania	26	5	31	0	0	0	0	0	0	31
Turkey	18	7	25	1	0	1	6	2	8	34
Yugoslavia	44	11	55	1	0	1	10	0	10	66
<b>Total Europe</b>	<b>345</b>	<b>53</b>	<b>398</b>	<b>3</b>	<b>0</b>	<b>3</b>	<b>34</b>	<b>7</b>	<b>41</b>	<b>442</b>

Table 3 (continued)

Nationality/home area, country or territory	Number of individuals placed									
	UNDP			Regular programme			Other programmes			Total
	Male	Female	Total	Male	Female	Total	Male	Female	Total	
<b>LATIN AMERICA AND THE CARIBBEAN</b>										
Antigua	3	0	3	0	0	0	0	0	0	3
Argentina	4	0	4	0	0	0	1	0	1	5
Barbados	4	0	4	0	0	0	0	0	0	4
Bolivia	7	0	7	0	0	0	2	0	2	9
Brazil	3	2	5	0	0	0	6	4	10	15
Chile	0	1	1	0	0	0	3	0	3	4
Colombia	1	0	1	0	0	0	2	0	2	3
Costa Rica	1	0	1	0	0	0	12	1	13	14
Cuba	3	3	6	0	0	0	0	0	0	6
Ecuador	3	1	4	0	0	0	3	0	3	7
El Salvador	0	0	0	0	0	0	1	0	1	1
Guatemala	0	0	0	1	0	1	4	3	7	8
Guyana	5	2	7	0	0	0	0	0	0	7
Honduras	2	1	3	0	0	0	0	0	0	3
Jamaica	7	0	7	0	0	0	0	0	0	7
Mexico	24	0	24	0	0	0	3	0	3	27
Nicaragua	8	1	9	0	0	0	1	0	1	10
Paraguay	6	0	6	0	0	0	0	0	0	6
Peru	0	0	0	0	0	0	4	0	4	4
Suriname	1	0	1	0	0	0	0	0	0	1
Trinidad and Tobago	2	2	4	0	0	0	2	2	4	8
Venezuela	2	1	3	0	0	0	7	1	8	11
<b>Total Latin America and the Caribbean</b>	<b>86</b>	<b>14</b>	<b>100</b>	<b>1</b>	<b>0</b>	<b>1</b>	<b>51</b>	<b>11</b>	<b>62</b>	<b>163</b>
<b>GRAND TOTAL</b>	<b>1,361</b>	<b>242</b>	<b>1,603</b>	<b>29</b>	<b>2</b>	<b>31</b>	<b>278</b>	<b>32</b>	<b>310</b>	<b>1,944 b/</b>

a/ African Arab States (Algeria, Egypt, Libyan Arab Jamahiriya, Morocco, Sudan and Tunisia) included under "Arab States".

b/ Including 276 females, 212 individuals from least developed countries, 411 individuals from African countries (including African Arab States).



Table 4

Fellowships and study tours started in 1990, by country,  
geographical area or territory of study a/, b/

Country/geographical area/ territory of study	Number of individuals placed			Total
	UNDP	Regular programme	Other programmes	
Algeria	4	1	0	5
Argentina	0	0	12	12
Australia	69	0	1	70
Austria	50	2	23	75
Austria (UNIDO Headquarters)	62	10	7	79
Bangladesh	6	0	0	6
Belgium	47	2	10	59
Bolivia	1	0	0	1
Brazil	28	3	1	32
Bulgaria	5	0	5	10
Burkina Faso	2	0	0	2
Canada	30	0	0	30
Chile	0	0	2	2
China	22	0	0	22
Colombia	4	0	1	5
Costa Rica	3	0	6	9
Côte d'Ivoire	10	0	1	11
Cuba	1	3	0	4
Cyprus	1	0	0	1
Czechoslovakia	45	0	24	69
Denmark	50	0	16	66
Egypt	18	0	5	23
El Salvador	0	0	1	1
Ethiopia	1	0	2	3
Fiji	1	0	0	1
Finland	27	0	1	28
France	180	2	46	228
Germany	245	0	16	261
Greece	1	0	0	1
Grenada	1	0	0	1
Guatemala	1	0	1	2
Guinea	1	0	0	1
Guyana	3	0	0	3
Haiti	2	0	0	2
Honduras	0	0	1	1
Hong Kong	15	0	11	26
Hungary	31	1	4	36
Iceland	1	0	0	1
India	107	0	8	115
Indonesia	19	0	3	22
Iraq	6	0	0	6
Ireland	12	2	0	14
Israel	1	0	0	1
Italy	135	0	44	179
Jamaica	3	0	0	3
Japan	48	0	17	65
Jordan	4	0	0	4
Kenya	4	0	0	4
Madagascar	0	1	0	1
Malaysia	22	0	1	23

Table 4 (continued)

Country/geographical area/ territory of study	Number of individuals placed			Total
	UNDP	Regular programme	Other programmes	
Mali	2	0	0	2
Mauritius	1	0	0	1
Mexico	8	0	3	11
Morocco	5	0	0	5
Netherlands	65	3	9	77
New Zealand	9	0	0	9
Nicaragua	0	0	3	3
Nigeria	1	0	0	1
Norway	15	0	0	15
Pakistan	11	0	3	14
Panama	0	0	1	1
Peru	3	0	1	4
Philippines	23	0	5	28
Poland	35	0	0	35
Portugal	19	0	0	19
Puerto Rico	0	0	4	4
Republic of Korea	38	1	0	39
Saudi Arabia	1	0	0	1
Senegal	1	1	0	2
Singapore	28	0	5	33
Spain	32	0	3	35
Sri Lanka	25	0	0	25
Sweden	24	0	1	25
Switzerland	47	0	3	50
Thailand	89	0	2	91
Togo	3	0	0	3
Trinidad and Tobago	4	0	0	4
Tunisia	6	3	2	11
Turkey	3	0	8	11
Uganda	1	0	0	1
Union of Soviet Socialist Republics	25	2	2	29
United Arab Emirates	3	0	0	3
United Kingdom	238	1	22	261
United Republic of Tanzania	7	0	0	7
United States of America	194	0	14	208
Venezuela	2	0	0	2
Viet Nam	1	0	0	1
Yemen	3	0	0	3
Yugoslavia	5	0	24	29
Zaire	1	0	0	1
Zimbabwe	1	0	0	1
<b>TOTAL</b>	<b>2,308</b>	<b>38</b>	<b>385</b>	<b>2,731</b>

a/ Where a fellowship/study tour included more than one country/geographical area/territory, it is listed against each one concerned. Thus the totals in table 4 do not correspond to those in table 3.

b/ Of these placements 798 or 29.2 per cent were arranged in developing countries, thus contributing to technical co-operation among developing countries.

## APPENDIX J

## AGREEMENTS CONCLUDED BY UNIDO IN 1990

Agreements with StatesAustria

Exchange of letters between the Permanent Representative of Austria to UNIDO and the Director-General of UNIDO for the continuation from 1 February 1990 to 31 January 1993 of the project concerning the UNIDO Service in Austria for the strengthening of industrial co-operation and promotion of investment with developing countries, dated 29 January

Burundi

Basic co-operation agreement between the United Nations Industrial Development Organization and the Government of the Republic of Burundi, signed on 25 June

Costa Rica

Letter of understanding between the United Nations Industrial Development Organization and the Government of Costa Rica, signed on 5 April

Cuba

Basic co-operation agreement between the United Nations Industrial Development Organization and the Government of Cuba, signed on 9 May

Memorandum of understanding between the United Nations Industrial Development Organization and the Government of Cuba on a joint programme of international co-operation in the area of sugar cane derivatives, signed on 18 June

France

Exchange of letters between the Permanent Representative of France to UNIDO and the Director-General concerning specific activities in the food industry sector, signed on 7 and 8 August

India

Exchange of letters between the Permanent Representative of India to UNIDO and the Director-General concerning the extension of the basic terms and conditions governing UNIDO projects envisaged by the interim programme for the International Centre for Genetic Engineering and Biotechnology, dated 28 February

Italy

Exchange of letters between the Permanent Representative of Italy to UNIDO and the Director-General concerning the extension from 15 September 1989 to 31 December 1994 of the UNIDO Service in Milan, Italy, for the promotion of industrial investment

in developing countries (to be renamed "UNIDO Office in Italy (Milan)"), dated 5 March

Exchange of letters between the Permanent Representative of Italy to UNIDO and the Director-General concerning the extension until 30 June 1995 of the basic terms and conditions governing UNIDO projects envisaged by the five-year work programme for the International Centre for Genetic Engineering and Biotechnology, signed on 12 and 19 December

Exchange of letters between UNIDO and the Research Area of Trieste regarding the extension until 31 December 1990 of the 1989 agreement and related rental agreement, dated 10 May and 5 June; a further exchange of letters regarding the extension until 31 December 1991 of the 1989 agreement and related rental agreement, dated 8 November and 19 December

Japan

Memorandum concerning the interregional project of the UNIDO Service in Japan for the promotion of industrial investment in developing countries, signed on 31 August

Togo

Basic co-operation agreement between the United Nations Industrial Development Organization and the Government of Togo, signed on 26 November

Turkey

Memorandum of understanding on industrial development between the United Nations Industrial Development Organization and the Government of Turkey, signed on 10 July

Agreements with the United Nations,  
specialized agencies and other  
organizations within the  
United Nations system

United Nations

Agreement between the United Nations and the United Nations Industrial Development Organization on arrangements for the sale of UNIDO publications, signed on 10 and 17 December

Specialized agenciesFAO

Agreement between the United Nations Industrial Development Organization and the Food and Agriculture Organization of the United Nations, signed on 4 May

Subsidiary organs of the United Nations

Habitat

Agreement between UNIDO and the United Nations Centre for Human Settlements on the co-sponsorship of the Second Consultation on the Wood and Wood Products Industry, signed on 14 April and 21 June

ITC

Memorandum of understanding concerning co-operation between the United Nations Industrial Development Organization and the International Trade Centre UNCTAD/GATT, signed on 28 September and 30 October

UNDP

Arrangements between the United Nations Development Programme and UNIDO concerning the Junior Professional Officer programme (based on the memorandum of understanding concerning the integration of the UNIDO field service within the UNDP field office), signed on 23 February

Agreements with other intergovernmental organizations

ACCT

Relationship agreement between the United Nations Industrial Development Organization and the Agency for Cultural and Technical Co-operation, signed on 22 November

BDEAC

Relationship agreement between the United Nations Industrial Development

Organization and the Central African States Development Bank, signed on 5 January and 13 February

ICSTI

Relationship agreement between the United Nations Industrial Development Organization and the International Centre for Scientific and Technical Information, signed on 22 September and 29 October

JUNAC

Relationship agreement between the United Nations Industrial Development Organization and the Commission of the Cartagena Agreement, signed on 16 November 1989 and on 22 January 1990

SACEP

Relationship agreement between the United Nations Industrial Development Organization and the South Asia Co-operative Environment Programme, signed on 9 November and 27 December

WADB

Relationship agreement between the United Nations Industrial Development Organization and the West African Development Bank, signed on 18 May

Agreements with other institutions

ICE

Agreement regarding co-operation between the United Nations Industrial Development Organization and the Italian Institute of Foreign Trade, signed on 23 April



Distr.  
GENERAL

IDB.S/10/Corr.1  
27 June 1991

United Nations Industrial Development Organization

ORIGINAL: ENGLISH

Industrial Development Board

Eighth session  
Vienna, 1-5 July 1991  
Item 4 of the provisional agenda

ANNUAL REPORT OF UNIDO, 1990

Corrigendum

Page 25, table 13, column 1, entry for the total

After Total delete technical co-operation expenditure

Page 65, paragraph 9

Line 14: For 126 read 127

Line 23: For \$22.05 million read \$22.09 million

Page 129, table 1

After the entry for Lesotho insert

Liberia	0	41,886	-1,279	0	0	-3,796	36,811
---------	---	--------	--------	---	---	--------	--------

The entry for the subtotal should read

Subtotal	1,228,531	9,307,699	657,782	0	1,379,302	1,316,806	13,890,120
----------	-----------	-----------	---------	---	-----------	-----------	------------

Page 130

The entry for the total should read

TOTAL	1,770,909	15,554,554	814,191	419,897	1,934,961	1,590,623	22,085,135
-------	-----------	------------	---------	---------	-----------	-----------	------------

Page 131, table 2

After the entry for Lesotho insert

Liberia	0	0	0	0	0	0	0
---------	---	---	---	---	---	---	---

Page 133, table 3

After the entry for Lesotho insert

Liberia	0	0	4,443	0	0	0	4,443
---------	---	---	-------	---	---	---	-------

The entry for the subtotal should read

Subtotal	2,154,715	14,534,233	412,280	0	721,405	579,917	18,402,550
----------	-----------	------------	---------	---	---------	---------	------------

Page 134

The entry for the total should read

TOTAL	3,096,032	20,965,448	660,230	178,914	1,168,379	282,762	26,351,765
-------	-----------	------------	---------	---------	-----------	---------	------------



Distr.  
GENERAL

IDB.8/10/Corr.2  
10 October 1991

United Nations Industrial Development Organization

ORIGINAL: ENGLISH

**Industrial Development Board**

Eighth session

Vienna, 1-5 July 1991

Agenda item 4

ANNUAL REPORT OF UNIDO, 1990

Corrigendum

Page 24, entry for Institutional infrastructure

Line (iii), subtotal: For 82 read 24

Total: For 271 read 213

Replace pages 88 and 89 by the attached text.

**A. Number of purchase orders placed in 1989**

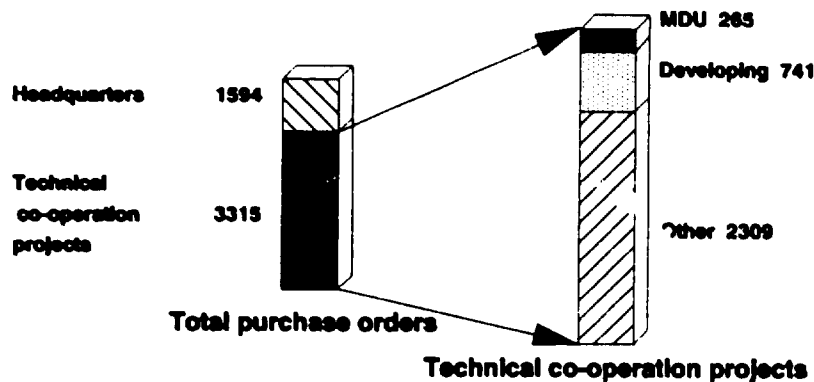

**B. Number of purchase orders placed in 1990**

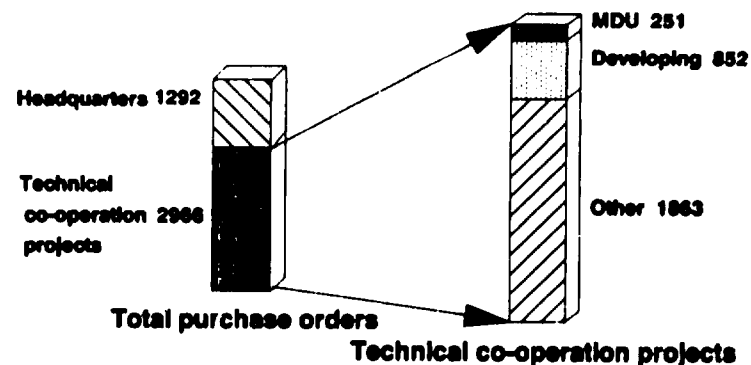

**C. Value of purchase orders placed in 1989  
(In millions of US\$)**

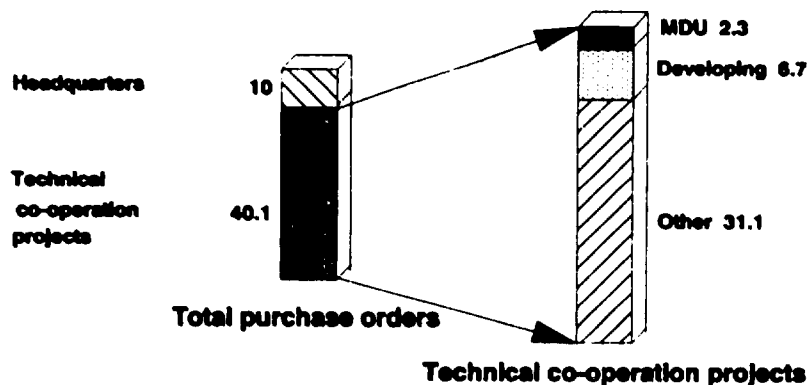

**D. Value of purchase orders placed in 1990  
(In millions of US\$)**

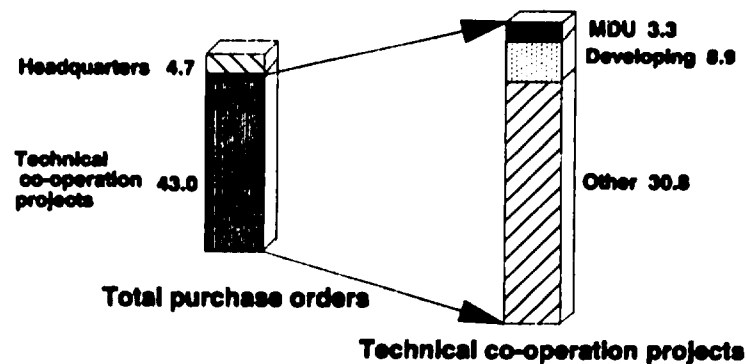

**Number and value of purchase orders placed, 1989 - 1990**

MDU = Major donor underutilized countries

**A. Number of contracts awarded in 1989**

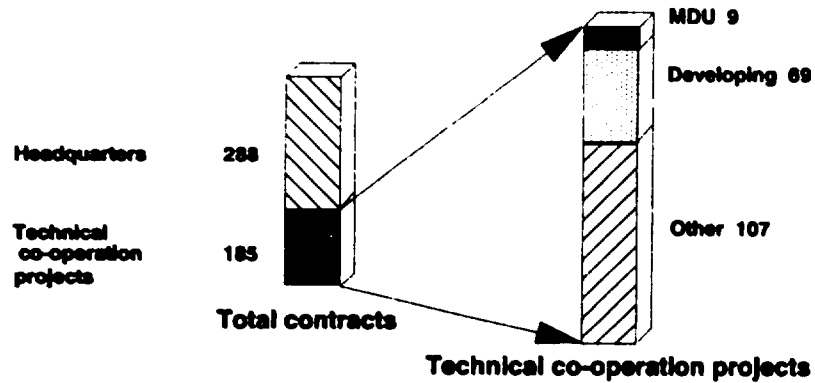

**B. Number of contracts awarded in 1990**

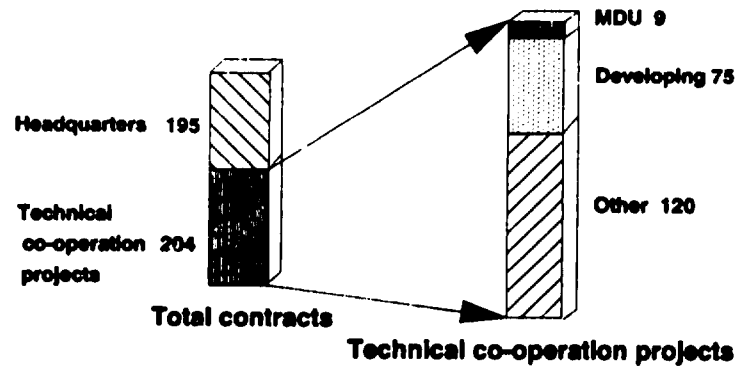

**C. Value of contracts awarded in 1989  
(In millions of US\$)**

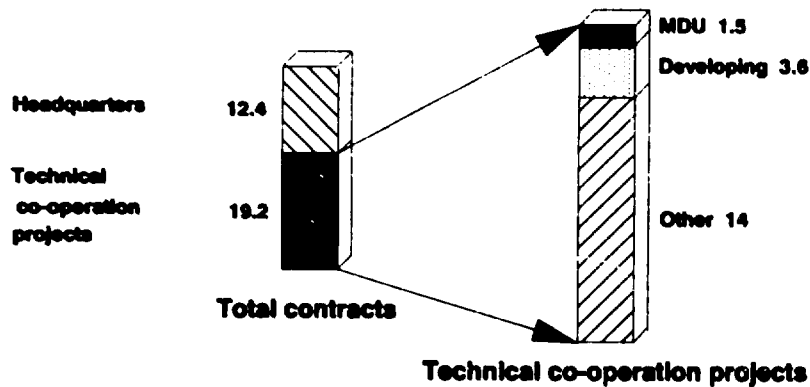

**D. Value of contracts awarded in 1990  
(In millions of US\$)**

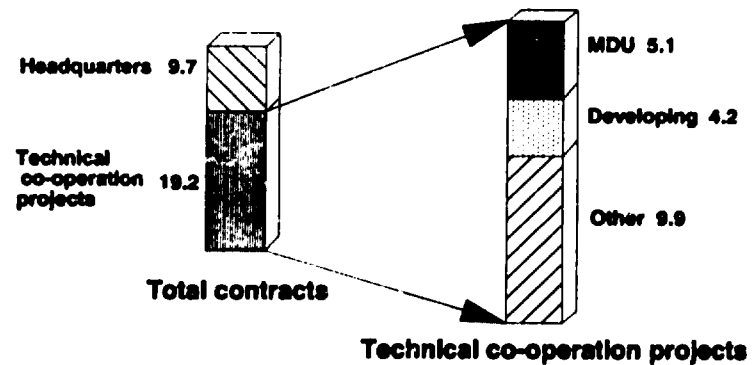

**Number and value of contracts awarded, 1989 - 1990**

MDU = Major donor underutilized countries