



**TOGETHER**  
*for a sustainable future*

## OCCASION

This publication has been made available to the public on the occasion of the 50<sup>th</sup> anniversary of the United Nations Industrial Development Organisation.



**TOGETHER**  
*for a sustainable future*

## DISCLAIMER

This document has been produced without formal United Nations editing. The designations employed and the presentation of the material in this document do not imply the expression of any opinion whatsoever on the part of the Secretariat of the United Nations Industrial Development Organization (UNIDO) concerning the legal status of any country, territory, city or area or of its authorities, or concerning the delimitation of its frontiers or boundaries, or its economic system or degree of development. Designations such as “developed”, “industrialized” and “developing” are intended for statistical convenience and do not necessarily express a judgment about the stage reached by a particular country or area in the development process. Mention of firm names or commercial products does not constitute an endorsement by UNIDO.

## FAIR USE POLICY

Any part of this publication may be quoted and referenced for educational and research purposes without additional permission from UNIDO. However, those who make use of quoting and referencing this publication are requested to follow the Fair Use Policy of giving due credit to UNIDO.

## CONTACT

Please contact [publications@unido.org](mailto:publications@unido.org) for further information concerning UNIDO publications.

For more information about UNIDO, please visit us at [www.unido.org](http://www.unido.org)

09983

Development and Transfer of Technology Series

No. **7**

**TECHNOLOGIES  
FROM DEVELOPING  
COUNTRIES (II)**

601701



TECHNOLOGIES FROM DEVELOPING COUNTRIES (II)

UNITED NATIONS INDUSTRIAL DEVELOPMENT ORGANIZATION  
Vienna

Development and Transfer of Technology Series No. 7

**TECHNOLOGIES  
FROM  
DEVELOPING COUNTRIES (II)**



UNITED NATIONS  
New York, 1980

The designations employed and the presentation of the material in this publication do not imply the expression of any opinion whatsoever on the part of the Secretariat of the United Nations concerning the legal status of any country, territory, city or area or of its authorities, or concerning the delimitation of its frontiers or boundaries.

Mention of firm names and commercial products does not imply the endorsement of the United Nations Industrial Development Organization (UNIDO).

Material in this publication may be freely quoted or reprinted, but acknowledgement is requested, together with a copy of the publication containing the quotation or reprint.

# Preface

The collection and dissemination of information on alternative technologies are essential prerequisites for the selection of alternative techniques and processes for production operations. This assumes particular significance in the context of technological absorption, adaptation and innovation in the developing countries and the use of techniques and processes more appropriate to socio-economic objectives and circumstances in these countries.

Compiling information on alternative technologies in industrial sectors is undoubtedly a complex task. The great number of industrial activities, enterprises and institutions makes it difficult to compile a comprehensive listing of alternative techniques, particularly of those available in developing countries. At the same time, for want of such a listing, entrepreneurs in developing countries have had to acquire technologies from industrialized countries, often perpetuating technological dependence even in sectors where more appropriate techniques would have been available locally or from another developing country.

An attempt has been made in this volume<sup>1</sup> to compile information on technologies which have been developed in certain sectors in developing countries and which can be acquired from sources in these countries. The sectors selected for this compilation are the industrial branches chosen for detailed discussion at the International Forum on Appropriate Industrial Technology in India, 20-30 November 1978.

It must be emphasized that the inventory of technologies described in this volume is by no means exhaustive even with regard to alternative techniques and processes available in these sectors in developing countries. There is little doubt that, apart from technologies developed in the research and development institutes, significant technological development has also taken place in a number of enterprises in these sectors. It has not been practicable for UNIDO to collect and compile information relating to technological developments in such enterprises. The information contained in the document should therefore be treated as only illustrative of the technological trends and developments in selected research and development institutes.

In preparing this volume, UNIDO undertook a survey of selected research and development institutes in developing countries through a questionnaire. In most cases all information received on a given technology or institute has been reproduced without selection. In a few cases a selection had to be made because of the large amount of information received not always pertinent to the subject. In the case where no or not enough information on technologies had been received through the UNIDO survey other sources have been used.

This volume is divided into two sections: section A describes the technologies, and section B the research and development institutes where the products and processes were developed.

Only those products or processes have been included that are available for introduction on a commercial scale. The heading "status of commercialization" indicates how to obtain the technology and to what extent it is available. No attempt has been made to evaluate the appropriateness of the techniques and processes to conditions in developing countries. It is considered that the suitability or otherwise of any of the techniques and processes listed should

---

<sup>1</sup> See also *Technologies from Developing Countries (I)*, Development and Transfer of Technology Series No. 7 (ID/208).

be considered in the context of specific factor circumstances and conditions of particular countries.

Finally, some selected information has been provided on publications on technologies and research and development institutes. These represent the most recent and comprehensive guides to more detailed information on research and development institutes and technologies for use in developing countries.

It is hoped that this publication will focus attention on the need for similar compilations at a national level in each country which could thereafter be compiled on a regional or international basis by UNIDO.

#### **Explanatory notes**

References to dollars (\$) are to United States dollars, unless otherwise stated.

A crore is 10 million.

A full stop ( . ) is used to indicate decimals.

A comma ( , ) is used to distinguish thousands and millions.

References to tons are to metric tons, unless otherwise specified.

The following abbreviations are used in this publication:

CSIR	Council of Scientific and Industrial Research (India)
G.I.	galvanized iron
M.S.	mild steel
SERC	Structural Engineering Research Centre

## CONTENTS

<i>Chapter</i>	<i>Page</i>
<b>A. Technologies</b>	
I. Chemicals and metalworking . . . . .	3
II. Drugs and pharmaceuticals . . . . .	8
III. Textiles . . . . .	10
IV. Cement and building materials . . . . .	16
V. Food storage and processing . . . . .	24
VI. Agricultural machinery and implements . . . . .	31
VII. Light engineering and rural workshops . . . . .	34
VIII. Oils and fats . . . . .	36
IX. Paper products and small pulp mills . . . . .	38
X. Energy for rural requirements . . . . .	41
XI. Low-cost transport for rural areas . . . . .	46
<b>B. Research and development institutes</b>	
I. Africa and the Middle East . . . . .	51
II. Asia and Oceania . . . . .	54
III. Europe . . . . .	60
IV. Latin America and the Caribbean . . . . .	61
<i>Bibliography</i> . . . . .	63
<i>Index of Technologies</i> . . . . .	64



## **A. Technologies**

# I. Chemicals and metalworking

## Thermophosphate production in mace roasting furnace

*Description.* Low-cost thermophosphate production for perennial plantation.

*Technical and economic details.* Apatite concentrate is submitted to a heat treatment in order to be transformed into a partially soluble product when exposed to humic acids. The process is essentially a partial smelting of apatite concentrate mixed with special slag-forming materials, in the form of pellets, using charcoal as fuel. The final product has the same amount of  $P_2O_5$  of which 50% becomes soluble.

*Status of commercialization.* A plant with a capacity of 100,000 tons was under construction in the state of Goiás, Brazil, and was expected to be in operation in December 1979. The process is covered by a Brazilian patent.

### Contact address

Instituto de Pesquisas Tecnológicas do Estado de São Paulo S.A. (IPT), P.O. Box 71411, 01000 São Paulo, Brazil

## Integral use of cellulosic residues by acid hydrolysis process

*Description.* Production technology for ethanol, lignin and other by-products from cellulose contained in renewable natural resources such as wood, agricultural wastes etc.

*Technical and economic details.* The process is a modified version of the Scholler process. Apart from contributing to the National Alcohol Programme, the utilization of this technology will have a major impact in the Brazilian steel-making industry, since Brazilian low-quality mineral coal renders the country dependent on heavy imports to satisfy industrial needs. Furthermore, the adoption of this technology will also generate income and employment benefits for rural and semi-urban communities throughout the country.

*Status of commercialization.* No patents applied for. A development and construction contract for a joint industrial plant is currently under negotiation between a major steel-making company in Brazil and the Instituto Nacional de Tecnologia.

### Contact address

Instituto Nacional de Tecnologia, Avenida Venezuela No. 82-7º Andar, Rio de Janeiro 20.081, Brazil

## Alumina from coal ash

*Description.* Process for extraction of high-purity alumina from the ash of coal briquettes.

*Technical and economic details.* The process developed is called the Lime-Soda-Coal Sinter (LSC) process. The composition of the ash of a typical coal briquette (used in Seoul) is 45%  $SiO_2$ , 30%  $Al_2O_3$  and 10% C. The LSC process is a new way of utilizing all these major components. The carbon content originating from incomplete combustion is used as part of the sintering fuel. About 80% of the alumina content is converted to metallurgical alumina (99%  $Al_2O_3$ ), and the rest to a lime silicate residue (85%  $Ca_2SiO_4$ ), an excellent feed material for Portland cement plants.

The main chemical reactions occurring in the rotary kiln are the calcination of added limestone, the gasification of coal and the lime-silica bonding by way of sintering at about 1,200°C. Part of the heat needed for the sintering comes from the combustion of coal in the feed, and the rest from that of oil or gas at the burner. The fuel ratio of coal/oil here is the most critical factor that determines the economic feasibility of the whole process.

Substitution of fuel oil by coal is possible because of the rapid combustion of the gasified products, and because of the high alumina content in the ash, which becomes part of the raw material for the process. The focus of the current rotary kiln test is on finding the upper limit of possible oil-saving that allows reasonable control of the sintering temperature and atmosphere. With 60% of the oil substituted by coal as targeted, the production cost is estimated to be \$140 per ton of alumina, which is \$20 less than the present import price (c.i.f.).

In the meantime, a process has been developed for extraction of alumina from domestic anorthosites. The LSC process is a combination of the rotary kiln operation with this. The potential feeds for the LSC process include not only coal briquette ash and anorthosite, but also coal ash from power plants, coal shale and various kinds of clays. These materials have similar constitutions and all lead to satisfactory

results in the laboratory. The fact that low-grade anthracites can be used as additional fuel indicates the emergence of potentially rich resources for heat and alumina. When commercialized, the greatest advantage of the process will be in the diversity of raw materials it can use.

*Status of commercialization.* Ready for commercialization. A patent has been filed.

*Contact address*

The Korea Institute of Science and Technology,  
P.O. Box 131, Dongdaemoon, Seoul, Republic of  
Korea

#### Copper-plated steel wire

*Description.* Process for the production of copper-plated steel wire for utilization as lead wire, especially as telephone cable, messenger wire and transmission cable.

*Technical and economic details.* Copper-plated steel wire is characterized by a combination of the electrical conductivity of copper and the mechanical strength of steel. In this project, suitable steel wire was continuously electroplated and then the wire was drawn and heat-treated. The copper-plated steel wire produced by the pilot plant has all the required characteristics for use as lead wire and also as various forms of cable. The production will have an import substitution effect of over \$3 million on the Korean economy.

*Status of commercialization.* The process is applied in commercial production.

*Contact address*

The Korea Institute of Science and Technology,  
P.O. Box 131, Dongdaemoon, Seoul, Republic of  
Korea

#### Mangrove extract

*Description.* Manufacture of mangrove extract for various uses.

*Technical and economic details.* The process yields a modified mangrove extract which could be used as a substitute for wattle and quebracho extract in the manufacture of different types of leather, particularly heavy, industrial and chrome retan leather. The product could also be used for the preservation of fishing nets, in oil-drilling operations, for the prevention of corrosion in boilers, in the textile industry etc.

The raw material requirement is 6,000 tons of bark annually. The fixed capital necessary for a plant of 1,500 tons per year capacity would amount to Rs 2 million.

*Status of commercialization.* The process is covered by the Indian Patent No. 99768.

*Contact address*

Central Leather Research Institute, Sardar Patel  
Road, Adyar, Madras 600020, India

#### Blend extract from myrobalan and babul/konnam

*Description.* Manufacture of blend extract from myrobalan and babul/konnam (rella) as a partial substitute for wattle extract in the manufacture of a variety of leathers.

*Technical and economic details.* The process consists of judicious blending of myrobalans, babul and konnam, and of water extraction, concentration and finishing. The raw material requirements for 1 ton of finished extract are: myrobalan nuts, 1.5 tons; babul bark/konnam bark, 3 to 3.5 tons. The following equipment is necessary: wooden leaching vats, disintegrator, toothed roller crusher, triple-effect evaporator, spray drier, boiler, and miscellaneous components. The total capital investment for a plant of 3 tons per day capacity amounts to about Rs 1.1 million including working capital.

*Status of commercialization.* Ready for commercialization.

*Contact address*

Central Leather Research Institute, Sardar Patel  
Road, Adyar, Madras 600020, India

#### Fertilizer from waste hair

*Description.* Simple process for making a fertilizer from waste tannery hair and waste human hair.

*Technical and economic details.* In the absence of enough synthetic fertilizers, products of this nature which are rich in nitrogen and are comparable to other farmyard manures will always have a demand particularly because they will be cheaper than the synthetic fertilizers and are not easily leachable.

*Status of commercialization.* Pilot plant trials are being completed.

*Contact address*

Central Leather Research Institute, Sardar Patel  
Road, Adyar, Madras 600020, India

#### Ethanol production from manioc roots

*Description.* Technology for producing ethanol (ethylalcohol) from manioc (cassava) roots to be used as a substitute for oil derivative fuels.

*Technical and economic details.* The steps of the process are: preliminary treatment of the raw material, cooking, saccharification, fermentation, distillation. Although not a very sophisticated process, it presents some special features such as non-newtonian fluids, control of enzyme activities, toxic substances. The appropriate adoption of this technology, particularly for smaller units of 10,000 litres per day in rural communities, would help to meet basic socio-economic needs, by generation of income and employment benefits. Furthermore, the following by-products are obtained and could be utilized: carbon dioxide (dry-ice, freezing of perishable rural products) and stillage (cattle feed, fertilizers).

The average agricultural capital investment is estimated at \$632 per hectare. The industrial capital investment for a plant with the capacity of 10,000 litres ethanol per day is estimated at \$900,000. At current ethanol prices and average operating costs a 14% return on investment could be achieved.

*Status of commercialization.* The process has been used commercially by Petrobrás in a 60,000 litre per day unit. Detailed engineering plans are in preparation for three new plants of 120,000 litres per day.

#### Contact address

Instituto Nacional de Tecnología, Avenida Venezuela No. 82-7° Andar, Rio de Janeiro 20.081, Brazil

#### Protective coating for metal parts (Plastipeel)

*Description.* Plastic protection for metal parts with indigenously available raw materials.

*Technical and economic details.* The process consists of making a jelly of a special grade of ethyl cellulose. This is a mixture of mineral and vegetable oils with specific antioxidants. The capital necessary for establishing a plant with a capacity of 1 ton per day is approximately Rs 100,000. The process is suitable for small- and medium-scale production.

*Status of commercialization.* The process has been commercialized since 1960.

#### Contact address

National Research Development Corporation of India, 61 Ring Road, Lajpatnagar III, New Delhi 110024, India

#### Improved PVC production

*Description.* Improved process to reduce and/or minimize the scale formation in PVC production.

*Technical and economic details.* The process has been developed by the Shri Ram Institute for Industrial Research. It involves the addition of special ingredients in the formulation that reduce the scale formation in PVC polymerization by 90%. The remaining scales can easily be cleaned by simple means.

*Status of commercialization.* The process is being commercially exploited.

#### Contact address

Shri Ram Chemical Industries, Kanchenjunga Building, Barakhamba Road, New Delhi 110001, India

#### Production of pancreatin for leather manufacture

*Description.* Production of pancreatin, a highly potent enzyme bate, which is used for bating different types of hides and skins in the process of leather manufacture. Pancreatin could also replace the imported product, which is used for the recovery of both silver and cellulose triacetate base from exposed photographic and X-ray films.

*Technical and economic details.* Well-minced animal pancreas is subjected to two sequential treatments for the complete conversion of the inactive enzyme precursors to highly active enzyme proper and then blended with cheap, indigenously available carriers of enzyme and ammonium salts, dried and powdered. All the machines and raw materials are available locally. It is easy to maintain the day-to-day production of standard quality bate. The capital investment for a plant with a capacity of 250 kg of bate per day per shift is estimated at Rs 60,000. The return on investment is estimated at 33%.

*Status of commercialization.* Indian Patent 2170/Cal/75.

#### Contact address

Central Leather Research Institute, Sardar Patel Road, Adyar, Madras 600020, India

#### Improved catalyst systems

*Description.* Improved process to enhance polymer production with the existing equipment at lower costs.

*Technical and economic details.* Production of a low-temperature polymer with increased rates of polymerization without any residual catalyst which may affect the polymer. The process has been developed by the Shri Ram Institute for Industrial Research.

*Status of commercialization.* Some of the catalysts have been in continuous use since 1960.

**Contact address**

Shri Ram Chemical Industries, 61 Ring Road,  
Lajpatnagar III, New Delhi 110024, India

**Manufacture of ABS plastics**

*Description.* Indigenously developed process for the manufacture of acrylonitrile butadiene styrene (ABS) plastics.

*Technical and economic details.* The process has been developed by the Shri Ram Institute for Industrial Research. Different grades of ABS plastics have been developed corresponding to international standards. The necessary capital investment for a plant with a capacity of 10 tons per day is approximately Rs 2 crores; the total investment would be the order of Rs 4 crores.

*Status of commercialization.* A semi-commercial plant has been in operation for three years. A commercial plant started production in May 1978. The process is at present licensed to three parties.

**Contact address**

National Research Development Corporation of  
India, 61 Ring Road, Lajpatnagar III, New  
Delhi 110024, India

**Dissolution of copper from copper sulphides**

*Description.* Improved process for recovering copper from low-grade sulphide ores.

*Technical and economic details.* Until now, the technologies for recovery of copper from low-grade sulphide ores were not economical and produced far more contaminants. The adapted process makes better use of local resources. Capital investment and the operation costs are lower than for flotation smelting process.

*Status of commercialization.* The process is applied in a pilot plant. An industrial plant was to take up production in 1979.

**Contact address**

Comité Contratante para Decisión 87, Junta del  
Acuerdo de Cartagena, P.O. Box 3237, Lima,  
Peru

**Carboxy methyl cellulose**

*Description.* Process for the manufacture of carboxy methyl cellulose from locally available raw materials. The product is used in oil exploration.

*Technical and economic details.* The process has been developed by the Shri Ram Institute for

Industrial Research. It consists of suspending shredded cellulose in alcohol and then adding aqueous caustic soda and chloroacetic acid at a temperature of 50°-70°C for about 3-5 hours; separating the resulting mass by centrifuging, washing and, if necessary, neutralization; and finally drying and disintegration. Special features of the process are the utilization of ethyl alcohol as a medium which is plentifully available in the country and the use of pulp from indigenous sources. The process is cheaper than the one offered by foreign countries. The approximate investment for a plant of 10 tons per day is estimated at Rs 5 million.

*Status of commercialization.* The process was licensed to Sardesai Brothers in 1970. Presently, licences are given to other parties as well. The process is covered by Indian Patent No. 62751.

**Contact address**

National Research Development Corporation of  
India, 61 Ring Road, Lajpatnagar III, New  
Delhi 110024, India

**Ethyl ether**

*Description.* Improved process for the production of ethyl ether.

*Technical and economic details.* The conventional sulphuric acid process for manufacture of ethyl ether presented many operational and maintenance problems. The salient feature of the improved process is a simplified reactor design which permits continuous operation. The process consists of catalytic dehydration of ethyl alcohol in gaseous phase using a fluidized bed system. The information on capital investment can be obtained from the licensee, Industrial Solvents Ltd., Bombay.

*Status of commercialization.* A plant has been in operation since 1963. The process is covered by Indian Patents Nos. 49836 and 60921.

**Contact address**

National Research Development Corporation of  
India, 61 Ring Road, Lajpatnagar III, New  
Delhi 110024, India

**Bisphenol-A**

*Description.* Process for the local production of Bisphenol-A as a substitute for the imported product.

*Technical and economic details.* The process has been developed by the Shri Ram Institute for Industrial Research. It consists of reacting phenol with acetone in the presence of sulphuric acid or

hydrochloric acid. The information on capital investment is available from the licensee (see contact address).

*Status of commercialization.* The process is under commercial exploitation.

*Contact address*

Raghunand Chemicals Pvt. Ltd., Mustafa Building, Feroze Shah Mehta Road, Bombay 1, India

### Pentaerythritol

*Description.* Cheaper process for the manufacture of Pentaerythritol.

*Technical and economic details.* The process has been developed by the Shri Ram Institute for Industrial Research. It involves reaction of acetaldehyde and formaldehyde under different conditions in the presence of an alkali followed by isolation of the product. The investment cost of a 10 tons per day plant is approximately Rs 15 million.

*Status of commercialization.* The process is under commercial exploitation and the know-how will be available to other parties on a turnkey basis.

*Contact address*

National Research Development Corporation of India, 61 Ring Road, Lajpatnagar III, New Delhi 110024, India

### Diallyl phthalate monomer, prepolymer and moulding compositions

*Description.* Process for production of diallyl phthalate monomer, prepolymer and moulding compositions. The product is used in the production of electronic components, dough moulding compositions and bonding and finishing agents for plywood.

*Technical and economic details.* The process has been developed by the Shri Ram Institute for Industrial Research. It is based on esterification reaction of allyl alcohol and phthalic anhydride, followed by vacuum distillation and polymerization of the pure monomer. The quality of the product meets international standards. A plant capable of producing 1 ton per day was designed at the Institute. It has been built and erected at the factory of the sponsors and has given the desired output. The capital investment for plant and machinery is estimated at Rs 750,000.

*Status of commercialization.* A plant was inaugurated in 1978 and is under commercial production.

*Contact address*

Western India Plywoods Ltd., Baliapatam, Cannanore District, Kerala, India

### Unsaturated polyesters

*Description.* Process for production of improved grades of resins such as glass reinforced polyesters.

*Technical and economic details.* The reactions are mainly with terephthalic or isophthalic acid, maleic anhydride and ethylene glycol. The process falls in the range of medium-scale industry. The approximate capital investment for a plant of 1 ton per day would be Rs 500,000.

*Status of commercialization.* The process has been commercially utilized since 1965. It is covered by Indian Patent No. 78016.

*Contact address*

Shri Ram Institute for Industrial Research, 19 University Road, Delhi 110007, India

## II. Drugs and pharmaceuticals

### Production of ethambutol

*Description.* Process for synthesizing ethambutol, a raw material for an anti-tuberculosis drug.

*Technical and economic details.* The Korea Institute of Science and Technology has developed an entirely new process. The synthetic process for ethambutol requires highly developed chemical technology, especially the technology of separating optical heterogeneities, with the result that the world market price of ethambutol is from \$120,000 to \$130,000 per ton. The domestic production thus will substitute imports.

*Status of commercialization.* Patents have been applied for. Commercial production has started.

#### Contact address

The Korea Institute of Science and Technology,  
P.O. Box 131, Dongdaemoon, Seoul, Republic of Korea

### Extraction of glue and gelatine

*Description.* Modified method for the extraction of glue and gelatine for various purposes.

*Technical and economic details.* Glue is used in the wood industry and gelatine in the pharmaceutical, food and photographic industries. As a by-product a proteinous material containing 10-14% nitrogen is produced which can be used as a nitrogenous fertilizer supplement.

By this method collagenous yields from 20-30% glue concentration could be dried without previous pre-concentration. This method has several advantages: (a) it saves thermal and other power inputs; (b) it saves total factory working time; (c) it needs smaller extraction vats; (d) it yields a purer product; and (e) it yields more glue.

*Status of commercialization.* Ready for commercialization. Application for a patent is under way.

#### Contact address

Central Leather Research Institute, Sardar Patel Road, Adyar, Madras 600020, India

### Coconut water as intravenous fluid

*Description.* Preparation of coconut water for use in intravenous replacement therapy.

*Technical and economic details.* Coconut water was aseptically withdrawn from the unripe fruit through a plastic trocar from a blood administration set into a sterile bottle, using a large-bore gauge 18 needle as a vent. This fluid was subsequently used for chemical analysis and for animal and human experiments *in vitro* and *in vivo*. Fresh coconut water was analysed for its electrolyte, sugar, protein and fat content. Other determinations were osmolarity, sterility, toxicity, pyrogenicity and antigenicity. Coconut water was found to be rich in potassium, low in sodium, sterile, non-pyrogenic, non-haemolytic, and non-antigenic. Preliminary studies using mice, rats, rabbits, dogs and monkeys indicated that coconut water is non-toxic and that intravenous infusion of it does not cause significant changes in the electrolyte composition, osmolarity, and pH of the blood of the experimental animals. 500-750 ml of coconut water infused intravenously in nine human volunteers from the Philippine General Hospital did not cause any significant change in the electrolyte composition of the blood. There was also no significant change in blood pressure, pulse rate or respiration and no untoward reactions of any type were observed.

*Status of commercialization.* No information received.

#### Contact address

National Institute of Science and Technology,  
P.O. Box 774, Manila, Philippines

### Improved strain of ergot

*Description.* Agro-technology for the cultivation of ergot with a higher percentage of alkaloids than the imported product.

*Technical and economic details.* Ergot alkaloids are obtained from ergot of rye (*sclerotium* of the fungus *Claviceps purpurea Tulasne*). The Central Indian Medicinal Plants Organization developed agro-technology for the cultivation of ergot. Pilot-scale cultivation has shown that an improved strain of ergot with 0.725% of total alkaloids and 0.4% ergotoxine could be obtained. The product imported from Europe had only 0.3% alkaloids. The average yield of ergot sclerotia is 100 kg per hectare. The yield is expected to be much higher in the temperate climate of Kashmir.

Hitherto, the strain of ergot produced in India was primarily meant for production of ergotamine. Recently a formulation of ergocristine, ergocryptine and ergocornine under the trade name Hydergine has been found to be effective in peripheral vasodilatation, increased blood flow and systematic lowering of blood pressure.

*Status of commercialization.* Production started on pilot scale.

*Contact address*

Central Indian Medicinal Plants Organization,  
Lucknow, India

### Methaqualone and methaqualone hydrochloride

*Description.* Process for producing methaqualone mainly from locally available raw materials. Methaqualone is an accepted non-barbiturate sedative used in pharmaceutical preparations.

*Technical and economic details.* The process involves reaction of anthranilic acid or isatoic anhydride with acetic anhydride. The acetylated product is isolated and refluxed in a suitable solvent with *o*-toluidine under suitable conditions when methaqualone is formed. Methaqualone is isolated from the reaction mixture as its hydrochloride and is purified by crystallization. The free base is obtained by basification of the hydrochloride.

The process has been standardized on a scale of 1-kg batch of methaqualone hydrochloride. A total quantity of 5-kg product has been prepared by the laboratory.

The raw materials required in the process are: isatoic anhydride or anthranilic acid, acetic anhydride, *o*-toluidine and hydrochloric acid.

The equipment required for the process is: 20-litre glass assemblies, filtration unit, vacuum pump, cooling water pump, tray drier and heating mantle.

The suggested capacity for an economically viable unit is 1 ton per annum. The capital investment

for such a unit is estimated at Rs 80,000 of which Rs 42,000 are for the plant and Rs 36,000 for working capital. The estimate does not include the capital requirements for land and building (80 m<sup>2</sup> approximately). The cost of product was estimated at Rs 137 per kg.

*Status of commercialization.* The process is commercially exploited.

*Contact address*

National Research Development Corporation of  
India, 61 Ring Road, Lajpatnagar III, New Delhi  
110024, India

### Silica gel production

*Description.* Low-cost production of silica gel of high purity (99%).

*Technical and economic details.* Silica gel is used mainly as a dehydrating agent. It is also used for separation of gases in petroleum refining, as a catalyst carrier in butadiene polymerization and in synthetic rubber production, and in the pharmaceutical industry. By this process, chemicals such as potassium silicate, silica sol, molecular sieve zeolites, magnesium trisilicate and calcium silicate could be manufactured, using the same equipment and machines. The process does not require elaborate arrangements such as dialysis for removal of electrolytes and thus the operation cost is low. Production cost is about Rs 10 per kg. The gel compares favourably with high-grade silica gel which sells at Rs 45 per kg. Its water absorption capacity is 42-44% at 92-95% RH, while normally the water absorption is only about 36% at 90-95% RH. The capital investment for a plant with a capacity of 50 tons per annum is estimated at Rs 278,000.

*Status of commercialization.* Three Indian firms have started the commercial production of silica gel.

*Contact address*

Regional Research Laboratory, Jorhat, India



### III. Textiles

#### High-tenacity cotton yarns by mercerization

*Description.* Improved method for mercerization of cotton yarns.

*Technical and economic details.* The yarn is unwound from a cone (see figure) and guided round a driver roller that is rotating in a small trough containing an alkali wetting agent. When the yarn is wet it is passed round a wheel that is immersed in a tank of 30% caustic soda solution. The number of wraps on the wheel is so adjusted that the yarn stays in the solution for 10 seconds. Here a good penetration of alkali and intra-crystalline swelling takes place. Then the yarn is passed round another wheel that is immersed in a tank of 10% caustic soda solution. It remains in this solution for 20 seconds and the number of wraps on the wheel is adjusted accordingly. Here, further intra-crystalline swelling takes place and the mercerization becomes complete. The thread then passes round a stretch wheel which consists of a double V-type pulley with an adjustable mechanism that allows the diameter of the two grooves to be changed in order to achieve a varying degree of stretch. Subsequently, the yarn passes round two more wheels. One is immersed in hot water (80°-90°C) and the other in 2% sulphuric acid. The newly processed thread is squeezed to remove excess water and then dried in a drying chamber by hot air while it is being wound on the take-up package.

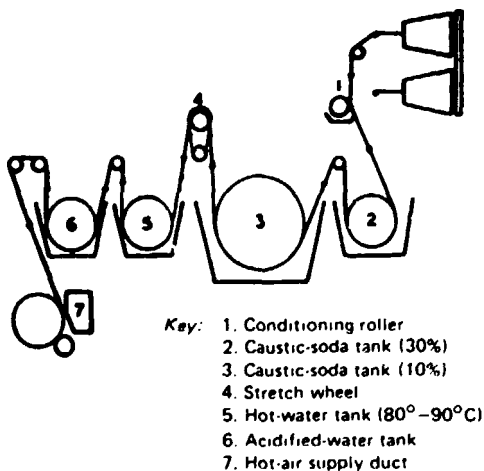

Single-end mercerization process

Capital investment is estimated at Rs 150,000. It is estimated that the yarn will cost more than the commercially mercerized sample, but the improvements in quality should compensate for the increase in cost.

*Status of commercialization.* Ready for commercialization.

#### Contact address

The South India Textile Research Association,  
P.B.No. 3205, Coimbatore Aerodrome Post,  
Coimbatore 641014, India

#### High-dome licker-in cover for carding engine

*Description.* Modified cover to minimize loss of fibres in carding engines.

*Technical and economic details.* The modified cover follows a contour that helps to create a low-pressure area above the licker-in. It can be fitted, with minor modifications, to an existing cover-bracket.

*Status of commercialization.* A licence has been issued. An application for patenting has been presented to the authorities.

#### Contact address

The South India Textile Research Association,  
P.B.No. 3205, Coimbatore Aerodrome Post,  
Coimbatore 641014, India

#### Double carding

*Description.* A system to improve the quality of spun cotton and blended yarns by double carding.

*Technical and economic details.* This double-carding system is simpler and cheaper than the conventional tandem card. Two cards, a semi-high production and a high production with crush rolls, have been combined. The carded material from the first card is passed over a highly polished, about 11 in. long plate that is inclined at an appropriate angle to the feed roller of the second card. Both cards are synchronized by a simple drive system. The material is carded twice, which results in cleaner and more uniform slivers. The yarns produced are more uniform, stronger and cleaner than the single-carded

yarns. Investment requirements for conversion of two semi-high production cards to double-card system is estimated at Rs 60,000.

*Status of commercialization.* A patent has been applied for. Negotiations are in progress with a prominent machinery manufacturer in India for commercialization.

*Contact address*

The South India Textile Research Association,  
P.B. No. 3205, Coimbatore Aerodrome Post,  
Coimbatore 641014, India

#### Single-yarn mercerization

*Description.* Process for mercerization of single yarns.

*Technical and economic details.* Mercerization is normally carried out on doubled yarns—the main reason being that they are much stronger than single yarns and can stand up better to the stretch. But these yarns are too expensive for the local knitting industries. By selecting the right type of cotton and varying the mercerizing parameters it is possible to produce mercerized single yarns with good lustre and other improved properties at a much reduced cost.

*Status of commercialization.* The technical know-how has been given to the industry.

*Contact address*

The South India Textile Research Association,  
P.B. No. 3205, Coimbatore Aerodrome Post,  
Coimbatore 641014, India

#### Use of unconventional fibres

*Description.* Method for processing of unconventional fibres on existing cotton-spinning machinery with appropriate adjustments.

*Technical and economic details.* A method has been developed for processing and spinning fibres of the cotton family such as ramie, jute etc., either pure or blended with other natural and man-made fibres. No high-capital expenses are necessary to implement this method.

*Status of commercialization.* The technology was transferred to rural industrial organizations and a project for the construction of a mini-mill has been submitted to the Ministry of Commerce.

*Contact address*

The South India Textile Research Association,  
P.B. No. 3205, Coimbatore Aerodrome Post,  
Coimbatore 641014, India

#### Crease-resistant raw silk fabrics

*Description.* Technology to produce crease-resistant raw silk fabrics.

*Technical and economic details.* The method was developed to make the very popular all-silk handloomed "raw silk" fabric crease-resistant so that it can meet the consumers' requirements regarding easy-care characteristics. The method consists of blending the silk with polyester fibre. The silk is cut to match the length of polyester fibre with which it is blended.

*Status of commercialization.* The know-how has been communicated to sponsors. Some organizations have already started to use this technique in the organized mill sector.

*Contact address*

The South India Textile Research Association,  
P.B. No. 3205, Coimbatore Aerodrome Post,  
Coimbatore 641014, India

#### Trash analyser

*Description.* Instrument for estimating the trash content.

*Technical and economic details.* The trash analyser can be used for the following purposes: (a) estimation of trash content in a sample of raw cotton; (b) estimation of trash content in lap or card sliver or in process stock from different points in the blowroom line; and (c) estimation of lint content or spinnable fibre in the waste from any machine. The instrument has been developed by the South India Textile Research Association (SITRA).

*Status of commercialization.* A licence has been issued.

*Contact address*

The Kasturi Engineers Pvt. Ltd., 218 Avanashi  
Road, Coimbatore 641018, India

#### Sriferet resins for textiles

*Description.* Process for giving better wash-and-wear properties to textile finishing.

*Technical and economic details.* The process has been developed by the Shri Ram Institute for Industrial Research. The special features of the process are a better chlorine resistant wash fastness and a "delayed cure" technique for producing durable press materials. The product developed is cheap and easy to manufacture, and does not deteriorate in storage. Information on capital investment may be obtained from the licensee, Sardesai Brothers, Bombay.

*Status of commercialization.* The process has been commercially exploited since 1961. It is covered by Indian Patents Nos. 65282, 52325 and 59835.

*Contact address*

Sardesai Brothers, 82 Advent, 8th Floor, 12-A, Gen. J. Bhouse Marg, Fort, Bombay 400001, India

**Srifericides for rot-proofing agents for textiles**

*Description.* Process for the development of improved types of rot-proofing agents for textiles.

*Technical and economic details.* The process has been developed by the Shri Ram Institute for Industrial Research. It involves condensation of carboxylic acids with organic anilides in the presence of phosphorous pentoxides. Unlike conventional copper naphthanate-based compounds, Srifericides do not adversely affect the treated materials. Because of their less corrosive nature they could be produced in stainless-steel vessels instead of in costly glass-lined equipment.

*Status of commercialization.* Commercial production started in 1963. The process is covered by Indian Patents Nos. 66794, 66795 and 83567.

*Contact address*

Shri Ram Institute for Industrial Research, 19 University Road, Delhi 110007, India

**Organdie finish**

*Description.* Improved process for finishing organdie.

*Technical and economic details.* The process has been developed by the Shri Ram Institute for Industrial Research. The fabric is treated with concentrated sulphuric acid in the presence of retardants/catalysts at controlled temperature and time. The process is cheaper than the one offered by foreign countries and gives equivalent results. Inquiries about capital investment should be addressed to the contact address.

*Status of commercialization.* The process has been commercially exploited since 1963 and most of the production has been exported. It is covered by Indian Patents Nos. 44808 and 52344.

*Contact address*

Finlay Mills Ltd., Chartered Bank Building, Mahatma Gandhi Road, Bombay, India

**Two-for-one twisting machine**

*Description.* Machine which inserts two turns of yarn twist for each revolution of the spindle.

*Technical and economic details.* The machine has been developed by the South India Textile Research Association in Coimbatore. The advantages of the two-for-one twist process are as follows:

1. For a given spindle speed, the production per spindle is double that of a ring twister. Also, the limiting spindle speeds are around 13,000 rpm and, therefore, the production per spindle on the two-for-one twisting system is two and a half to three times that of a ring twisting system.

2. Larger yarn packages (about 1 kg) are produced. This results in fewer knots in the doubled yarn, which is an added advantage in further processing. Also, owing to the large package produced, a lower doffing cycle results so that fewer operators are required for a given rewinding number of spindles.

3. Rewinding is eliminated and, hence, the cost of rewinding (machines and operators) is saved.

*Status of commercialization.* Licence issued for commercial manufacture.

*Contact address:*

The South India Textile Research Association, P.B. No. 3205, Coimbatore Aerodrome Post, Coimbatore 641014, India

**Staggering tappets**

*Description.* Mechanism to reduce damages during weaving.

*Technical and economic details.* In normal plain weaving all the yarns of one shed line cross all the yarns of the other shed line simultaneously, thus causing maximum yarn-to-yarn abrasion. If the yarns forming a shed line can be split into two or more layers while crossing the other set of yarns and also separated in two layers, the yarn abrasion during shedding can be reduced considerably. The abrasion of yarns in the reed dent and entanglements between yarns during shedding can also be reduced. This reduces the possibility of warp yarn breaks and hence better efficiency and less damage during weaving. For effective staggering it is necessary to move the four heald shafts independently by specially designed tappets which provide variable heald staggering achieved by moving the two heald shafts of the same shed line through different distances in a given time. Results of a number of mill trials indicate that a consistent reduction is obtained in the end breakage rates (20-25%). The mechanism has been developed by the Ahmedabad Textile Industry's Research Association.

*Status of commercialization.* The device has been used in several mills for some years. A licence is being issued.

**Contact address**

Poonjabhai Vanmali and Sons, Gheekantaz, Ahmedabad 380001, India, or Chesuni Engineering Works, C 3, Purnima Park, Near Jain Merchant Society, Paldi, Ahmedabad 380007, India

**Use of foam pads at sizing**

*Description.* Simple and efficient means of reducing the hairiness of sized yarn using foam pads to lay the protruding fibres in the wet, sized yarn.

*Technical and economic details.* Excessive hairiness in the warp yarn is known to increase the yarn-to-yarn abrasion on the loom and cause increased warp breakages. This affects the productivity of the loom and the incidence of cloth damage. To avoid these negative results, foam pads are mounted between the squeezing rollers and the first drying cylinder in a staggered fashion in such a way that they do not exert any pressure on the warp sheet. The technique can be used profitably to reduce warp yarn entanglement and yarn-to-yarn abrasion where the warp yarns used are more hairy (e.g. carded yarns and polyester/cotton blends); or, when weaving fabrics of heavy construction from a given yarn. The attachment can be easily fabricated in the mill's workshop itself and results in a 15% reduction in the warp breakage rate and a consequent increase in weave loom productivity. It reduces yarn-to-yarn abrasion and warp yarn entanglement and fabric defects.

*Status of commercialization.* Several mills are applying this technology.

**Contact address**

Ahmedabad Textile Industry's Research Association, Mechanical Processing Division, Ahmedabad 380015, India

**Improved mechanical slub catcher**

*Description.* Mechanical slub catcher for Rotoconer type winding machines. Its yarn clearing efficiency is considerably improved compared with the conventional fixed-blade slub catchers.

*Technical and economic details.* This slub catcher was developed by the Ahmedabad Textile Industry's Research Association. It is equipped with a suction unit to remove all the liberated fluff. Its use on non-automatic winding machines improves the weaving efficiency in the same way as does a modern

automatic winding machine. The improved slub catcher could replace the existing units on Rotoconer type winding machines. It is suitable for clearing both cotton and polyester blended yarns. In view of the improved clearing efficiency, the breakage rate at winding is often higher by about 50%, requiring a reallocation of spindles to a tenter.

*Status of commercialization.* Several mills have equipped their winding machines with this slub catcher. A licence has been issued.

**Contact address**

Kinariwala RJK Industry, Behind Anil Starch Products, Near Nicol Octroi Naka, Ahmedabad 380002, India

**Rapidry system for cylinder driers**

*Description.* Improved system for cylinder driers with increased drying speeds.

*Technical and economic details.* In cylinder driers a stagnant film of vapours forms over the drying surface and impedes evaporation. Air jets are used to disperse these vapours and increase the evaporation rate. Only ambient air is used and at the optimum velocity. The drying speed of a cylinder drier is increased by over 25%. The Rapidry system is most useful where drying is a bottleneck. It costs less than a tenth of a new machine but increases production by more than 25%. It requires no additional heating and can be installed on almost any cylinder drier without affecting the working of the machine. It saves energy.

*Status of commercialization.* Several mills are using this system.

**Contact address**

Ahmedabad Textile Industry's Research Association, Engineering Division, Ahmedabad 380015, India

**Auxiliary buffer for picking stick on overpick looms**

*Description.* Auxiliary buffer to reduce the consumption of accessory machinery in the weaving industry.

*Technical and economic details.* The excessive momentum of the picking stick after picking causes the stretching of the picking band, pulling up the loom spindle and the picker. The conventional buffer is ineffective in minimizing these strains, which cause frequent failures of these accessories. In order to absorb this momentum an auxiliary buffer was designed that acts directly on the picking stick once

picking is completed. The buffer consists of an L-bracket and a flexible cylindrical buffer made of rubberized canvas. The buffer can be fitted on any overpick loom.

*Status of commercialization.* The buffers have been installed in several mills.

*Contact address*

Ahmedabad Textile Industry's Research Association, Mechanical Processing Division, Ahmedabad 380015, India

#### Roof-cooling system

*Description.* Roof-cooling system in spinning and weaving departments as an aid to combat the excessive heat loads filtering into departments during hot summer days.

*Technical and economic details.* For roof cooling, water is sprinkled over the roof surface so that the surface temperature is brought down to about 30°C. This greatly reduces the heat transmitted through the roof. Diurnal atmospheric variations are almost completely evened out so that steady ambient conditions can be maintained in the department throughout the day. The air conditioning plants will require only very little adjustment from morning till evening. The cost of roof cooling is about a tenth of that of humidification plants (without refrigeration) of similar performance and the saving in installed power is about 40 to 50 kW for an average-sized mill.

*Status of commercialization.* The roof-cooling system has been introduced in several mills.

*Contact address*

Ahmedabad Textile Industry's Research Association, Engineering Division, Ahmedabad 380015, India

#### Modified rope washing machine

*Description.* Modified rope washing machine with reduced water consumption.

*Technical and economic details.* Washing machines consume about 25% of total water consumption in a mill. The tight and slack rope washing machines are commonly sturdy and give trouble-free service, but their washing performance is poor compared with modern machines. With the modified rope washing machines a reduction of water consumption in conventional bleaching process of about 35 to 40% has been achieved. The modified slack rope washing machines are also working satisfactorily in the continuous bleaching process in place of modern tensitrol washers. The capital cost of

modified slack rope washing machines is about one-third that of tensitrol washers.

*Status of commercialization.* The machine has been introduced in many Indian mills.

*Contact address*

Ahmedabad Textile Industry's Research Association, Engineering Division, Ahmedabad 380015, India

#### Swell release motion

*Description.* A mechanism consisting of two simple levers fitted on a non-automatic loom so as to periodically release the swell pressure on the shuttle.

*Technical and economic details.* The mechanism works only at the time of picking; at the time of checking, however, the swell pressure acts fully on the shuttle to retard it. It can be fitted on any non-automatic loom and has the following advantages: (a) reduced picking force and hence smoother running of the loom; (b) less wear and tear of accessories and hence longer life; and (c) reduced loom slip and hence higher production.

*Status of commercialization.* This device has been installed in several mills.

*Contact address*

Ahmedabad Textile Industry's Research Association, Mechanical Processing Division, Ahmedabad 380015, India

#### Fibre length tester

*Description.* Instrument for the measurement of length of cotton fibres.

*Technical and economic details.* An aligned tuft of fibres is scanned for optical transmission along the fibre axis. The distribution of optical density along the fibre tuft has been found to be highly correlated with the length distribution pattern obtained on comb sorters. An accessory to the instrument, the autosampler, prepares the aligned tuft for scanning. The instrument has been developed by the Ahmedabad Textile Industry's Research Association. It is reliable, simple to operate and inexpensive. Compared with the comb sorter method the testing time is reduced and the operator's bias largely eliminated.

*Status of commercialization.* Nearly 40 instruments are in regular use.

*Contact address*

Mahlo-Star Electronic Equipments Private Ltd., GIDC Plot No. 78/3, Makarpura, Baroda 390009, India

### Fibre fineness tester

*Description.* Instrument for estimating the fineness, maturity and  $M_c$  values of a fibre.

*Technical and economic details.* The instrument uses the air flow through a fibre plug to obtain a combined estimate of fineness and maturity (MH). A separate scale is also provided for the  $M_c$  values. The MH scale ranges from 1.5 to 7.0 and the  $M_c$  scale from 2.5 to 6.5, both in units of 0.1. At present refinements are being introduced to the instrument for obtaining separate indices for maturity and fineness as well as for measuring the fineness of man-made fibres. The instrument is reliable, simple to operate and inexpensive. It has been developed by the Ahmedabad Textile Industry's Research Association.

*Status of commercialization.* Nearly 200 instruments are in regular use.

#### Contact address

Scientific and Industrial Instruments Co., B-14,  
Industrial Estate, Polo Ground, Indore 3, India

### Short process of bleaching polyester/cotton blends

*Description.* Short process of bleaching polyester/cotton blends without the use of sodium chlorite.

*Technical and economic details.* In many mills, the daily production of polyester/cotton blends is less than 5,000 metres. The blends are bleached on jiggers which takes about 8-10 hours and expensive and imported sodium is used to get the required whiteness. In the process developed by Ahmedabad Textile Industry's Research Association the bleaching time is reduced by about 3 hours and the use of sodium chlorite can be eliminated. The process is about 30% cheaper than the conventional one.

*Status of commercialization.* Eight mills are using the process.

#### Contact address

Ahmedabad Textile Industry's Research Association,  
Chemical Technology Division, Ahmedabad  
380015, India

### Low-temperature cure catalyst for wash-and-wear finishing

*Description.* Cheaper method for easy-care finishing.

*Technical and economic details.* Low-temperature cure catalyst systems, viz., catalyst LCR for resin finishing and catalyst PD, have been developed. With catalyst LCR it is possible to cure the resin-treated fabrics at 110°C in 2-3 minutes. Catalyst PD is meant to cure the resin during the drying stage only. Hence the process of resin finishing would be pad and dry on stenter at about 140°C for 1 minute. These catalysts are comparable in performance to magnesium chloride. The storage stability of resin finishing solutions of both the catalysts has been satisfactory. There is no change in the tone of fabrics dyed with reactive dyes. Catalyst LCR permits the use of a lower temperature for curing. The polymerizer can be run at a lower temperature of 125°C, leading to substantial saving in power consumption. The cost of these catalyst systems is lower than that of magnesium chloride.

*Status of commercialization.* More than 20 mills have obtained the know-how of the catalyst systems.

#### Contact address

Ahmedabad Textile Industry's Research Association,  
Chemical Technology Division, Ahmedabad  
380015, India

### Stain remover for textiles

*Description.* Btranol is a milky white liquid used for removal of oil/grease stains from textiles.

*Technical and economic details.* The manufacture of Btranol essentially involves mixing components (solvents and detergents) in stages with a high-speed stirrer. On a pilot-plant scale, a locally made disperser (1.5 hp) can produce 20 to 30 kg. The product has the following advantages: (a) low cost of production; (b) it can be manufactured without special equipment; (c) it has a better performance than other comparable products; and (d) raw materials used are indigenous.

*Status of commercialization.* A licence has been issued to an Indian firm. The product is being widely used in the country.

#### Contact address

The Bombay Textile Research Association, Lal  
Bahadur Shastri Marg, Chat Kopar (West),  
Bombay 400086, India

## IV. Cement and building materials

### Cement from rice husk ash

*Description.* Process for the manufacture of Ashmoh, a cement from rice husk ash and lime.

*Technical and economic details.* The rice husk ash (90% of silica) is mixed with dry slaked lime and ground in a ball-mill to achieve a fine powder which can be used as cement.

The ideal location for setting up an Ashmoh plant is near a rice mill that uses rice husk as fuel for parboiling the rice. Alternatively, the husk should be field-burnt in a proper way to yield a good variety of ash.

A plant with 500 tons per year capacity could be set up with an investment of Rs 100,000.

*Status of commercialization.* Patents have been obtained for the process. A 500 tons per year plant is under production.

#### Contact address

The Director, Indian Institute of Technology,  
Kanpur 208016, India

### Foam concrete

*Description.* Process for manufacturing foam concrete by incorporation of controlled amounts of stable foam in the cement mix using an indigenously developed foaming agent.

*Technical and economic details.* The foaming agent, marketed under the trade name of Balcrete, was sold in liquid form and was based on hydrolysed proteins stabilized by suitable chemicals to produce improved foam volume and foam stability. Balcrete is comparable in performance to Mearlcrete and Elasticell manufactured in the United States of America.

In recent years know-how for producing foam concrete using non-proteinous composition was developed. This composition cannot be marketed as a stable product but can be easily made on the site in pots and pans.

In a conventional concrete mixer the ingredients of the foam compound are added to the required quantity of water (4-8 oz/bag of cement), and mixed for 3-5 minutes; then the cement is added in small quantities and mixed thoroughly until the batch

appears homogeneous. The slurry obtained is cast into wooden moulds, which are removed after 12-24 hours, and the blocks are cured like conventional concrete. For casting foam concrete *in situ* on roofs, the roof area is divided into 6-12 ft wide strips of separate wood forms into which the foam concrete is poured to a level of 2-3 in.

The mix is very easy to handle and presents no problem. The density can be controlled by a number of factors such as the quantity of foaming agent, the length of the mixing cycle, the type of mixer and the water/cement ratio. A special portable whisking machine was designed for the manufacture of foam concrete. This machine costs less than the conventional cement mixers and produces one batch in 6-8 minutes.

*Status of commercialization.* Licences have been issued (on a non-exclusive basis) and the process is commercially applied.

#### Contact address

Pakistan Council of Scientific and Industrial  
Research, Press Centre, Shahrah-e-Kamal  
Ataturk, Karachi 01090, Pakistan

### Masonry cement from waste lime sludge and Portland cement

*Description.* Process for the manufacture of masonry cement using waste lime sludge and ordinary Portland cement.

*Technical and economic details.* The process involves intergrinding of waste lime sludge with Portland cement and the required quantity of gypsum. A small amount of an air-entraining agent may also be added, if required, for any special use. But even without such an agent the lime-sludge-based calcium carbonate sludges possess good workability and water retention properties. The manufacture of limestone/slag and Portland cement clinker blend masonry cements involves considerable intergrinding cost which is reduced substantially by using lime sludges. Besides, this process offers a direct utilization and useful means of disposal of the waste sludge from sugar factories and paper mills.

Manufacture of masonry cement can be taken up on either a small or large scale depending upon the quantity of lime sludge available. No large-scale plant and machinery are required except a ball-mill and a

set of sieves. The capital investment for a 6,000 tons per year plant is estimated at Rs 160,000.

*Status of commercialization.* The process has been licensed to three parties for commercial production.

*Contact address*

Central Building Research Institute, Roorkee (U.P.), India

**Cement binder from waste lime sludge and rice husk**

*Description.* Very simple process for the manufacture of a cement binder from waste lime sludge and rice husk. The production can be established in rural areas for rural development projects.

*Technical and economic details.* A new hydraulic binder possessing properties similar to Portland cement has been developed from the waste lime (from industries such as sugar, acetylene, paper, tanning etc.) and rice husk. The binder produced can be used in place of cement for certain construction applications. The process of production of the binder is quite easy and can be adopted on a small-scale industry level. The binder is consequently cheap and can also be manufactured by the rural population itself.

Dry waste lime sludge and rice husk are mixed together thoroughly in the proportion of 1:1 by weight or 1:2 by volume. The required amount of water is added to the dry mix for making balls or cakes by hand. These balls/cakes are put in the open for drying before burning. They are then fired in the open on a jalli (grating) base of a clamp or in a trench. Rice husk not only acts as integral fuel but also provides *in situ* silica for the lime produced during firing.

The fired material obtained is quite soft. Its reactivity increases with increasing fineness. Therefore, it is ground in a ball-mill to achieve sufficient fineness.

The total capital investment for a production of 5 tons per day amounts to Rs 120,000.

*Status of commercialization.* No commercial unit has so far been set up.

*Contact address*

Central Building Research Institute, Roorkee (U.P.), India

**Manufacture of plaster of Paris**

*Description.* Process for continuous production of hemihydrate for calcium sulphate.

*Technical and economic details.* Powdered gypsum is charged to vertical shaft kiln wherein it meets the counter-current of hot air. The process is efficient, economical and continuous in operation and yields a product of uniform quality. The process has been developed by the Shri Ram Institute for Industrial Research.

*Status of commercialization.* The process is applied in commercial production.

*Contact address*

National Building Organization, Ministry of Works and Housing, Nirman Bhavan, Maulana Azad Road, New Delhi, India

**Funicular shell roof**

*Description.* Low-cost, simple technology for production of roofing elements.

*Technical and economic details.* This process uses a minimum of materials (cement and steel) to a maximum structural advantage with the resulting material savings (steel: up to 40%) and cost reduction (25%). The roofing element is a thin shell whose shape is chosen in such a way that it carries loads in compression. The technology can be used in rural, urban and metropolitan areas. The equipment needed consists of a wooden mould, a masonry platform and a piece of sacking. The precast elements measure about 4 ft x 4 ft and weigh only 275 lb and could be easily resin-treated fabrics at 110° in 2-3 minutes. Catalyst and need no steel reinforcement except for edge beams (a single 3/8 in. diameter bar). After the elements are put together the surface is levelled by a layer of concrete. The space between the edge beams is concreted to form an intersecting system of grid beams. The roof presents a pleasing waffle pattern.

The elements can also be used for floors in multi-storey buildings because they are strong enough to carry a load of 300 lb per square foot.

*Status of commercialization.* The process has been patented and is available to interested parties. It has been extensively used in housing projects in Egypt, India, Iran and the USA.

*Contact address*

Structural Engineering Centre, CSIR Complex, Adyar, Madras 600020, India

**Light-weight aggregate from urban sewage slime**

*Description.* Process for the production of light aggregate for construction from sewage slime.

*Technical and economic details.* The sewage slime is submitted to a dehydration process that is followed by stages of self-sintering with no additional



fuel. The final sinter is crushed and sized. The cost of a pilot plant for 1 m<sup>3</sup>/hour production is \$1 million.

Details of the process were published in the *Brazilian review Revista DAE*, vol. 36, No. 104/1976.

*Status of commercialization.* An industrial plant is under construction in the city of São Paulo. The process is covered by a Brazilian patent.

*Contact address*

Instituto de Pesquisas Tecnológicas do Estado de São Paulo S.A. (IFT), P.O. Box 71411, 01000 São Paulo, Brazil

**Corrugated roofing panels from agricultural residues**

*Description.* Process of conversion of fibrous agricultural residues, such as bagasse from sugar cane, into a corrugated fibre roofing panel providing stiffness and load-carrying properties comparable to corrugated galvanized iron sheets.

*Technical and economic details.* The process is labour-intensive and requires low capital investment. The construction material produced by it is as durable as galvanized iron if protected with impregnants or coatings, such as asphalt and aluminium paint.

The process consists of five sets of operations: hammermilling and air separation of fines and pith; soaking, beating and screening for further pith removal; addition of chemical additives and oriented mat formation; mat pressing; post treatment such as trimming, asphalt coating or vacuum impregnation with preservatives and painting with aluminumized asphalt coating.

The capital required for a plant with a capacity of 250 panels per day amounts to \$56,000. Cost of roofing panel will be \$0.15 per ft<sup>2</sup> (including the depreciation of investment over 5 years). Chemical costs are estimated on prices in developing countries.

*Status of commercialization.* No details received.

*Contact address*

University of Washington, College of Forest Resources, Seattle, Washington 98195, USA

**Wood wool boards**

*Description.* Process for the manufacture of wood wool boards on a small scale.

*Technical and economic details.* Wood wool board is a material made from wood fibre (wood wool) and cement. Wood wool is saturated with cement slurry and compressed in the form of a board. The board is of medium density, i.e. 300 to

500 kg/m<sup>3</sup> and open texture and because of that it is used primarily as a thermal and acoustic insulation material. The board has good bending properties and can be used as a structural panel material. Other characteristics of wood wool board are its inherent resistance to fire and termite attack. Its surface can be plastered and all coating materials, including bitumen, can be used.

The Central Building Research Institute, Roorkee, has developed a simplified method for making cement-bonded wood wool boards that does not require heavy investment. The use of a heavy press has been totally eliminated.

The process utilizes wood wool obtained by the use of a wood-wool-making machine and a cement binder which could be ordinary Portland cement or magnesium oxychloride cement. A mixture of wood wool and cement binder is spread in a wooden mould by hand and compressed by hand-operated jacks. The boards are cured for 24 hours and demoulded and then further cured to gain the desired strength.

For a production of 75,000 boards per year (200 cm x 50 cm x 2.5 cm) in a three-shift operation (300 working days per year) a fixed capital of Rs 182,000 and a working capital of Rs 70,000 is required.

*Status of commercialization.* The process has been licensed to seven parties. There is no patent involved in this process. The material is already being produced in India.

*Contact address*

Central Building Research Institute, Roorkee (U.P.), India

**Corrugated roofing sheets from coir waste or wood wool**

*Description.* Process for the manufacture of corrugated roofing sheets from coir waste or wood wool, using Portland cement as binder.

*Technical and economic details.* Coir fibres or wood wool are soaked in mineralized water for 2 hours. The drained-off water is then mixed with dry cement. Next, a mat of suitable thickness is formed on a corrugated mould and pressed. It is held under pressure for 4 to 8 hours. After demoulding the sheet is cured and dried.

Wood wool/coir fibre corrugated sheets require 30% less cement than the asbestos cement sheets. They are light and sturdy and can be transported over hilly and rough roads without breaking. The sheets have good thermal insulation properties and are waterproof and fire-resistant. Their preparation needs neither heavy machinery nor high capital investment. The sheets are 50% cheaper than asbestos cement sheets.

The total capital investment for a production of 45 sheets per day (150 cm x 90 cm) amounts to Rs 110,000.

*Status of commercialization.* The process has been licensed to five parties, one of which has started trial production.

*Contact address*

Central Building Research Institute,  
Roorkee (U.P.), India

### Resin/natural fibre composites

*Description.* Process for combining natural fibres with resins yielding a construction material for buildings, bins, boats etc.

*Technical and economic details.* It has been found that when natural fibres, such as jute, are combined with unsaturated polyester resins (thalic anhydride and malic anhydride and propylene glycol) the resultant composite was highly suitable for use in construction of schools, clinics, houses and warehouses that can withstand cyclones, heavy monsoon and the effects of prolonged exposure to the tropical sun.

The fibrous material is spun on a large drum, and then passed through a resin bath. Within a few hours the product is dry and taken off the drum which is then ready for re-use.

The technology has been developed by the Bangladesh Jute Mills Corporation. It allows for an application in a labour-intensive, small-scale manner.

*Status of commercialization.* The process is ready for commercialization. A transfer of this technology to Tanzania is being considered.

*Contact address*

Bangladesh Jute Mills Corporation, c/o Inter Pares, G.P.O. Box 311, Dacca, Bangladesh

### Building lime from sugar press-mud

*Description.* Process for the manufacture of lime for building purposes from waste lime sludge of sugar industry (carbonation process).

*Technical and economic details.* Sugar press-mud (lime sludge) is a waste material both in the carbonation and sulphitation processing sugar mills. Whereas a considerable portion of press-mud from sugar mills using the sulphitation process finds use as a fertilizer, the press-mud from carbonation sugar mills does not find any use as it contains mainly calcium carbonate. This mud can be used as building lime after calcination.

Press-mud is available in powder form. Calcination of the powder in the commonly used mixed type

kilns is not practicable unless it is made into briquettes of suitable size. Hence, briquetting of press-mud was first taken up. It was found that about 6,000 lb/in.<sup>2</sup> pressure was necessary to produce briquettes of a strength sufficient to withstand the load in a 15-20 ft high mixed-feed kiln. The optimum firing temperature was also found to be 950°-1,000°C.

In large-scale trials dry press-mud in powder form with 15-20% water was fed to a briquetting plant. The briquettes were sun-dried and then calcined. The product obtained was analysed and usually conformed to the Indian Standards Specifications. The magnesium oxide content rarely exceeded 5%. The cost of press-mud lime is lower than that of comparable material. The capital investment in a plant of 20 tons per day capacity is estimated at Rs 78,000.

*Status of commercialization.* The process has not yet been used commercially, but several field trials have been carried out. There is no patent involved in this process.

*Contact address*

Central Building Research Institute,  
Roorkee (U.P.), India

### Manufacture of puzzolana clays

*Description.* Process for continuous activation of clays to increase the puzzolanic efficiency.

*Technical and economic details.* Powdered clays are charged into a vertical shaft in which they flow counter-current to the upgoing system of hot air. The process is of special use and importance to developing countries, since it does not involve huge capital investment as is normally required for cement plants. Such plants can be located in close proximity to the clay source to avoid costly transportation. The process has been developed by the Shri Ram Institute for Industrial Research.

*Status of commercialization.* The product is commercially manufactured.

*Contact address*

National Building Organization, Ministry of Works and Housing, Nirman Bhavan, Maulana Azad Road, New Delhi, India

### Lime burnt clay puzzolana mixture (LBCPM)

*Description.* Cost-saving process to produce LBCPM as a partial substitute for cement.

*Technical and economic details.* LBCPM is produced by intergrinding burnt clay puzzolana with dry hydrated lime. It is a ready-to-use cementing

material and can be used as a strength-based economical substitute for cement for certain categories of civil engineering work, such as pavement bases, masonry mortars and plasters, foundation concretes, precast construction, airfield bases and lightweight concrete etc. The technology was developed by the Central Road Research Institute in New Delhi.

LBCPM mortar and concrete mixes are about 30% more economical than cement mortars and concretes of equivalent strength.

The burnt clay puzzolana and dry hydrated lime are mixed and ground in a ball-mill of suitable capacity in stipulated proportions of one part of lime and two to three parts of burnt clay puzzolana by weight, and ground to fine mesh size to produce LBCPM.

Hydrated lime should be Indian Standard (IS) class "C" variety lime. Fineness: 90% passing IS 150 micron sieve.

It is estimated that for small-scale manufacture of 5 tons a day the outlay involved will be approximately Rs 250,000-300,000 which includes the cost of land and civil engineering works, the plant, machinery and laboratory equipment and the working capital for three months.

The present-day consumer cost is expected to be around Rs 120 per ton (controlled price of cement is Rs 260 per ton). Studies have shown that dolomitic limestone has a much higher magnesia content than is permissible for cement manufacture and can be used successfully for making LBCPM. Since dolomitic limestone is much cheaper than the calcitic one, considerable additional savings can be made.

*Status of commercialization.* Indian Patent No. 90470-1960-65.

*Contact address*

National Research Development Corporation of India, 61 Ring Road, Lajpatnagar III, New Delhi 110024, India

**Burnt clay puzzolana (reactive surkhi)**

*Description.* Process for the production of reactive material which can be used as partial replacement of cement (up to 20-25% of weight) in all cement mortar and concrete works.

*Technical and economic details.* The manufacture of reactive surkhi involves a correct choice of suitable clay, its controlled calcination and its pulverization to the required fineness. The material may be used also in the manufacture of puzzolana cement.

Down-draught kiln of batch type can be successfully used for small-scale manufacture. Its operation is easy and may be conducted by semi-skilled workers.

The process has been developed by the Central Road Research Institute of New Delhi.

Although the capital investment required will vary from place to place, depending upon the cost of land, raw material, transport and labour charges, it is estimated that for small-scale manufacture of 5 tons per day, the outlay involved will be approximately Rs 200,000-250,000, which includes the cost of land and civil engineering works, plant machinery and laboratory equipment and working capital for 3 months.

The advantages of this technology are: (a) conservation of cement in large quantities; (b) cheaper mortars and concretes (about 10%); (c) improvement of the physical properties of mortars and concretes, including reinforced concrete; and (d) opening up of employment through small-scale industry.

*Status of commercialization.* Indian Patent No. 93726-1960-65.

*Contact address*

National Research Development Corporation of India, 61 Ring Road, Lajpatnagar III, New Delhi 110024, India

**Large-size clay products with improved strength**

*Description.* Process to modify the properties of ordinary brick clay with suitable admixtures so as to yield fired products such as tiles, pipes etc. having higher tensile strength.

*Technical and economic details.* The main feature of this process is that a special body mix is used in place of the ordinary clay mix for making the pipes and corrugated clay sheets. The tensile strength of these products after firing is quite high. The corrugated clay sheets can be made by hand-moulding and pipes by extrusion. Large-size sheets and pipes can be made without any warping during drying and firing. Handling, drying and firing losses are almost negligible. The weight, 30 kg/m<sup>2</sup>, of a roof laid with clay sheets is much lower than that with Mangalore pattern tiles, which is 54 kg/m<sup>2</sup>. The sheets are easy to lay and handle and can be drilled and sawn.

Corrugated clay sheets can be used as a roofing material particularly for rural housing and for low-cost housing. The pipes can be used for irrigation in rural areas.

Adoption of this process will reduce the ultimate cost of the roof as compared to the clay tile roof and asbestos-cement roof. As such, the production cost of corrugated clay sheets is quite comparable to that of the clay tiles. The clay sheets and pipes are much cheaper than the asbestos-cement sheets and pipes. In the case of clay sheets the cost of the supporting structure is much less than that for clay tiles.

Any locally available alluvial brick clay having 25-40% clay fraction is suitable for making clay

sheets and pipes. The other raw materials are glass wool and red oxide iron and the addition is about 3-4% by the weight of clay. Pipes can be extruded well with the addition of wollastonite also. Clay sheets can also be made with the addition of wollastonite and glass wool. The quantity of glass wool can be reduced when wollastonite is added to the mix.

A fixed capital of Rs 95,000 and a working capital of Rs 35,000 is required. According to the laboratory and field trials the production cost of the corrugated clay sheets of 150 cm x 60 cm size and 10-12 mm thickness is about Rs 2.16 per sheet. The production cost of clay pipes of 5 cm internal diameter, 8 mm thickness, is about Rs 0.50 per metre.

*Status of commercialization.* A patent has been taken out. The process has been demonstrated on a large scale with the help of existing units, but so far no licence has been issued.

#### Contact address

Central Building Research Institute,  
Roorkee (U.P.), India

#### Clay flooring and roofing tiles

*Description.* Process for the manufacture of improved quality clay flooring and roofing tiles from alluvial clays.

*Technical and economic details.* Clay flooring and roofing tiles are one of the cheapest building materials commonly used in South India. They can be used for flooring in rural and urban housing and light-duty floors in industrial buildings, school and health buildings. The Central Building Research Institute has developed a process for the manufacture of improved quality tiles from alluvial clays possessing a flexural strength above  $160 \text{ kg/cm}^2$  and a water absorption of less than 10%.

The flooring tiles are resistant to abrasion and impact and can easily be laid or replaced. Owing to the scarcity and high cost of cement and steel, these tiles are a suitable alternative for low-cost construction.

Plastic alluvial clays containing illitic or the kaolinitic group of clay minerals and free from nodular lime or aggregates can be used for the manufacture of these tiles. The clay mixture containing lean and plastic clays must contain:

Clay	28-35%
Total fines	65-75%
Plasticity index	more than 20%

The mixture of lean and plastic clays in suitable proportions is weathered by alternate wetting and drying for a period varying from 2 to 3 months.

Weathered soil is pugged mechanically in a pug mill and left for a period of 1 or 2 weeks. The pugged mass is tempered, repugged and clay slabs of suitable size are hand-moulded or extruded. The slabs are pressed to roofing or flooring tiles by a hand-driven screw press. The tiles are dried slowly under shade, and fired in a down-draft kiln at a firing temperature range of  $850^\circ\text{-}950^\circ\text{C}$ .

Pilot plant work, consisting of several batches of production in a commercial kiln near Roorkee, was carried out. One 6.09-m diameter down-draft kiln with a capacity of 25,000 tiles per batch is required to manufacture 750,000 tiles per year (300 working days) at a capital expenditure of Rs 212,000.

*Status of commercialization.* The process has not yet been utilized commercially, but several large-scale field trials have been conducted in collaboration with the tile industry. There is no patent involved in this process.

#### Contact address

Central Building Research Institute,  
Roorkee (U.P.), India

#### Manufacture of ceramic floor tiles

*Description.* Process for the manufacture of ceramic floor tiles.

*Technical and economic details.* The process developed 10 substitutes for improved tiles using 100% local raw materials: only feasible as part of a ceramic factory.

*Status of commercialization.* It is being negotiated with the State Ceramic Corporation.

#### Contact address

Ceylon Institute of Scientific and Industrial Research, P.O. Box 787, Colombo 7, Sri Lanka

#### Production of wall tiles from unrefined china clay

*Description.* Bench-scale production of wall tiles using unrefined china clay.

*Technical and economic details.* By using unrefined china clay (containing mainly quartz and feldspar as impurities) the cost of the tiles may be considerably reduced. The tiles are covered with an opaque glaze.

*Status of commercialization.* A pilot plant is being established.

#### Contact address

National Council for Scientific Research,  
P.O. Box CH 158, Chelston, Lusaka, Zambia

### Production of floor tiles from red burning clay

*Description.* Bench-scale production of floor tiles using a red burning clay.

*Technical and economic details.* Floor tiles were manufactured on a bench scale using a red burning clay and feldspar. The tiles were fired at 1,200°C and the porosity was less than 2%.

*Status of commercialization.* A pilot plant is in the planning stage.

#### Contact address

National Council for Scientific Research,  
P.O. Box CH 158, Chelston, Lusaka, Zambia

### Production of acid-resistant bricks from red burning clays

*Description.* Bench-scale production of acid-resistant bricks using red burning clays.

*Technical and economic details.* Acid-resistant bricks which are used in the copper refining industry are manufactured on a bench scale with red burning clay and grog by an extrusion process.

*Status of commercialization.* It is hoped that the Zambia Clay Industries will take up the technology and produce the bricks on a commercial basis.

#### Contact address

National Council for Scientific Research,  
P.O. Box CH 158, Chelston, Lusaka, Zambia

### Soil/cement brick-making machine

*Description.* Hand-operated press for making soil/cement building blocks (modified CINVA Ram).

*Technical and economic details.* In the early 1950s the Inter-American Housing and Planning Centre (CINVA) in Bogota, Columbia developed a simple hand-operated press for the production of building blocks from soil/cement. This CINVA Ram has been modified in Zambia to eliminate some deficiencies. The bricks can be produced at low cost and withstand high temperatures and most weathers.

*Status of commercialization.* About 50 machines are in use in Zambia.

#### Contact address

Technology Development and Advisory Unit,  
P.O. Box 2379, Lusaka, Zambia

### Coconut pith as expansion joint filler and building board

*Description.* Process to produce an expansion joint filler for road pavements and for building and packing material from the non-fibrous tissue of the coconut husk.

*Technical and economic details.* Concrete slabs in road pavements, runways, bridge decks etc. expand and contract owing to the rise and fall of temperature. In order to adapt to these changes, joint filler material is needed with the following properties: (a) good compressibility, (b) high recovery after compression, (c) adequate resistance to water, (d) resistance to weathering, (e) stability, and (f) adequate strength against handling. Coconut pith is the elastic corklike material forming the non-fibrous tissue of the coconut husk which, in combination with a few indigenous products, could be used for the manufacture of low-cost expansion joint filler boards. It is estimated that at present 350,000 tons of coconut pith are available as a waste product from the coir industry. On account of its poor cellulose content (35%) this material has no place in the pulp industry.

Raw coconut pith is cleaned of sand and grit by sieving and washing with water, then mixed with an animal glue solution (3% by weight of animal glue made into a 4% solution in hot water) in a non-staining tray. Compounded rubber latex is used as a binder (mixture of 28% rubber latex and 0.25% of vulcanizing paste made of Z.D.C. sulphur and zinc oxide, both by weight of the pith). The vulcanizing paste is prepared in an 0.12% ammoniacal solution of 3.5% casein by weight of the vulcanizing agents. The mixing process is completed as quickly as possible in order to avoid clogging. The mixture is then kept in the oven at 50°-60°C for 24 hours for curing. Cured material is pressed in a pre-heated press at a pressing load of 75 psi for 15 minutes. The prepared board is allowed to dry slowly to avoid warping and is then treated with a solution of bitumen in kerosene oil, as a protection against microbial attack.

Cost of production of the board is Rs 13.50/m<sup>2</sup>, ½ in. thick and Rs 21/m<sup>2</sup>, ¼ in. thick.

The boards, suitably modified, could also be used for insulation, building and packing material, sealing caps etc. The process was developed by the Central Road Research Institute.

*Status of commercialization.* Indian Patent No. 87958.

#### Contact address

National Research Development Corporation of India, 61 Ring Road, Lajpatnagar III, New Delhi 110024, India

### Utilization of fly-ash

*Description.* Techniques for the use of fly-ash in pavement construction.

*Technical and economic details.* Fly-ash is a waste material and about 4.5 million tons per annum are being produced in Indian power plants, disposal of which costs about Rs 10 million.

A semi-rigid behaviour is observed when lime and fly-ash mixture is used as a bonding medium in pavement construction.

Lime-fly-ash concrete as a sub-base or base course in pavements spreads the load over larger areas; owing to greater resistance to penetration of water, the performance of such pavements is better than other conventional materials. Initial cost is at par with conventional base construction but savings will result because of better long-term performance. As precast blocks the concrete is suitable for construction of footpaths. The blocks are topped with a thin layer of cement sand mortar for better resistance to abrasion.

Lime-fly-ash-sand-bound macadam as base course is about 5-8% dearer than conventional material; in view of its superior performance and expected long life, a saving in maintenance costs could be achieved in the long run.

Lime-fly-ash-stabilized soil as sub-course in pavements gives superior performance and long service life. It is economical wherever stones are costly.

*Status of commercialization.* Ready for commercialization.

#### Contact address

Central Road Research Institute, Delhi Mathura Road, New Delhi 110020, India

### Low-grade materials for road construction

*Description.* New techniques for construction of low-traffic roads with low-grade materials, such as

laterite, gravel, coral etc. in areas where hard stone is not available.

*Technical and economic details.* Low-grade materials had not been considered acceptable for road construction, since, compared to stone, they usually have a low crushing strength or are found to be mixed with other materials. Considerable research work has been carried out to investigate the possibility of their use in the construction of road pavements either in their natural state or in combination with other stabilizing material. The engineering properties and other physico-chemical characteristics of these materials are now known. It has been shown that most of these abundantly available and so-called inferior materials can successfully replace the more expensive stone or brick in road construction. Investigations have also shown that since the magnitude of load stresses in the lower layers of pavement crust is low, a suitable processed and well-compacted soil can replace stone for a part of crust thickness in the lower layers.

Not all materials for road construction could be found on the surface. It was possible to establish through aerial photography well-defined and distinct patterns of the hidden deposits of these materials.

According to their engineering properties locally available low-grade materials are used in the different layers of a pavement. The engineering properties of these low-grade materials may be improved by the addition of small percentages of lime, cement, bitumen etc.

The advantages of these techniques are savings of up to 30% in comparison with conventional road construction, and their labour-intensiveness.

*Status of commercialization.* The techniques are being used in different parts of the country.

#### Contact address

Central Road Research Institute, Delhi Mathura Road, New Delhi 110020, India

# V. Food storage and processing

## Ferrocement bins

*Description.* Process for producing precast ferrocement cylindrical units for grain storage, water tanks, biogas holders and pipes etc.

*Technical and economic details.* The ferrocement bins developed at SERC, Roorkee, are cylindrical in shape and are assembled from prefabricated units, e.g. reinforced concrete based slabs, ferrocement wall units and dome-shaped ferrocement roof units. A wall unit has a diameter of 120 cm and a height of 100 cm. Depending on the individual consumer's requirement, 1-, 2- or 3-ton bins may be assembled by erecting one, two or three wall units one over the other and filling up the joints with cement mortar. A manhole is provided in the roof unit for loading and an outlet is provided in the bottom wall unit for

unloading the grain. Rubber gaskets are provided for both the inlet and the outlet to make the bins airtight. Locking arrangements are provided for the inlet and the outlet openings. The external surface of bins is painted with bituminous aluminium paint to make them moisture-proof.

The sizes of the various components of the bins have been so selected that these units can be handled and erected by four or five persons. The base slab, which is the heaviest of the prefabricated components, weighs about 160 kg. The cylindrical shape is preferred for the wall unit because it is suitable for mass production at the factory level. These cylindrical wall units are cast using the semi-mechanized process developed at SERC, Roorkee. The diagrammatic representation of the equipment is shown in figure I. The details of the various prefabricated components of 1-, 2- and 3-ton capacity bins are given in figure II.

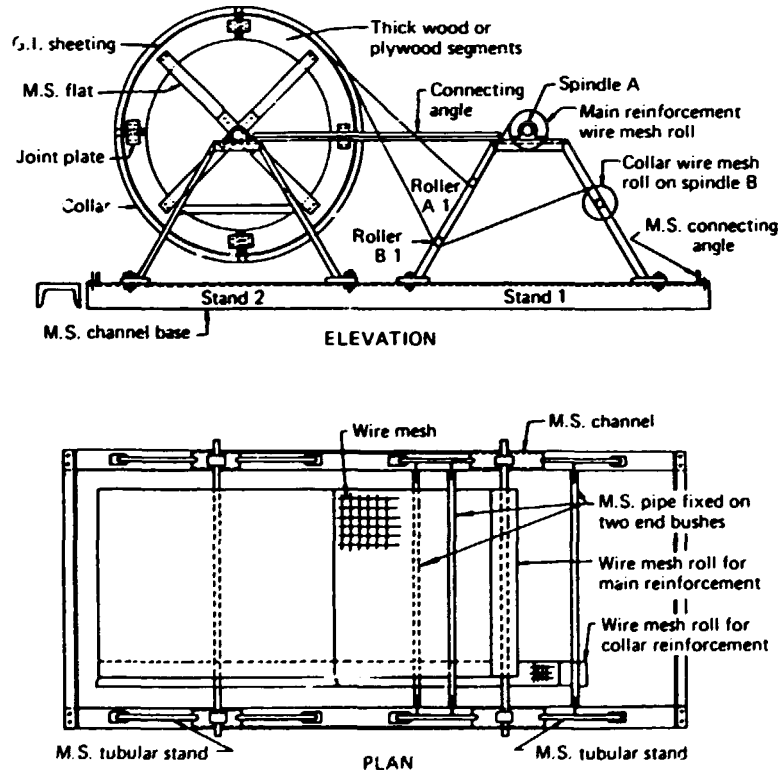

Figure I. Casting process for cylindrical ferrocement wall units

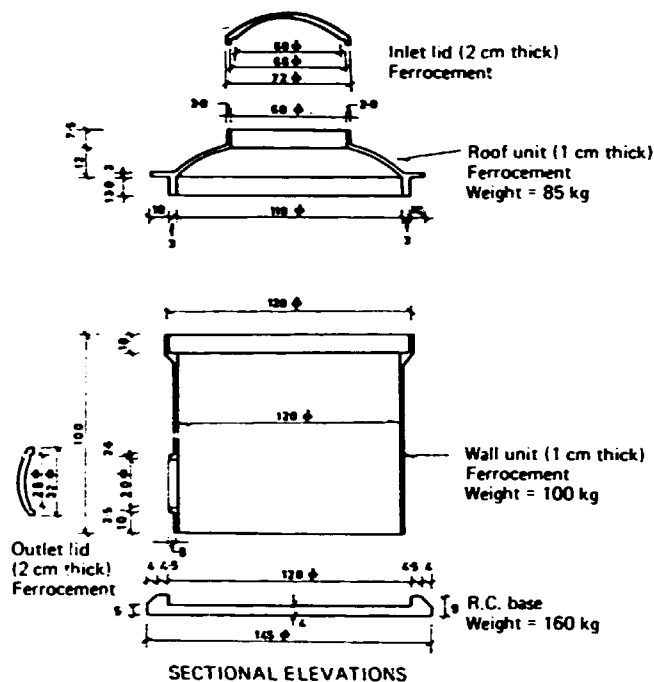

Figure II. Prefabricated units for bins up to 3-ton capacity

The equipment for casting wall units consists of a wooden cylindrical collapsible mould resting on two A-frames. A wire mesh spindle feeds wire mesh during casting. The process of casting consists of a manual application of cement mortar on wire mesh. The application is done layer by layer until the required thickness is obtained. After 24 hours the mould along with the casting is removed from mild steel frames and the unit is demoulded. The wall unit is given a finishing coat on the inside surface and is cured for 28 days.

The ferrocement bins possess the following advantages: (a) they are cheaper than steel bins, reinforced concrete bins and aluminium bins; (b) they are lighter than conventional reinforced concrete bins; (c) they require little or no maintenance; (d) the condensation and moisture migration problems in the stored food grains are much less compared to steel bins; (e) they can be easily fabricated at the rural level; (f) the fabrication technique is simple and can be easily acquired by the local labourers; (g) they are rodent-proof, fireproof, moisture-proof and can be made airtight easily by sealing the inlet and the outlet openings; (h) any structural damage can be easily repaired by plastering over the wire mesh.

*Status of commercialization.* A patent has been filed for the process. The process is commercially applied.

#### Contact address

Structural Engineering Research Centre, CSIR Complex, Adyar, Madras 600020, India

#### Ferrocement tanks for liquid storage

*Description.* Low-cost technique to produce ferrocement liquid storage tanks using unskilled labour.

*Technical and economic details.* The structure is a frame of steel bars and fence wire covered with a mortar of sand and cement; it is 2.5 cm thick. A synthetic lacquer, applied internally, is used for sealing. The cost is very low when compared to the cost of an ordinary asbestos-cement storage tank. This kind of tank can be built in any size required and may especially serve remote rural areas.

*Status of commercialization.* Ready for commercialization.

#### Contact address

Instituto de Pesquisas Tecnológicas do Estado de São Paulo S.A. (IPT), P.O. Box 71411, 01000 São Paulo, Brazil



### Naranjilla concentrate

*Description.* Processing and packaging of the naranjilla (*Solanum quitoenses*).

*Technical and economic details.* Naranjillas are processed into a greenish amber heavy syrup with a high-soluble solid content. This product is packaged into vacuum-sealed cans that can be stored for one year. The syrup is used in nectar, juice, soft drinks and the production of frozen confections.

*Status of commercialization.* The process is commercially applied.

#### Contact address

Instituto de Investigaciones Tecnológicas,  
Avenida 30 No. 52-A-77, Bogota, Colombia

### Dehydrated vegetables

*Description.* Production and packaging of dehydrated vegetables.

*Technical and economic details.* Carrots, spinach, spinach beet, onion or garlic are dehydrated and processed into flakes or powder. The product is packaged either in cans containing nitrogen or in cellophane or polyethylene bags. It is intended for use by other industries, mainly in spices, foods for infants and instant soups. Specific advantages of the product are: same quality as a fresh ingredient; production volume and price are stabilized; no refrigeration required; retention of nutritive factors; reduction of handling charges; quick reconstitution.

*Status of commercialization.* The process is commercially applied.

#### Contact address

Instituto de Investigaciones Tecnológicas,  
Avenida 30 No. 52-A-77, Bogota, Colombia

### Dehydrated potatoes

*Description.* Production and packaging of dehydrated potatoes.

*Technical and economic details.* The potatoes are processed either in the form of flakes (4% moisture) or slices of different shapes (4% moisture). Both products are well protected in polyethylene film bags. Their storage life is one year at 14°C under a relative humidity of 70%. Specific advantages of the product are low-cost handling and wrapping, long-term storage, no refrigeration required and stabilization of prices paid to farmers.

*Status of commercialization.* The process is commercially applied.

#### Contact address

Instituto de Investigaciones Tecnológicas,  
Avenida 30 No. 52-A-77, Bogota, Colombia

### Vegetable-textured protein

*Description.* Processing of soya beans into vegetable-textured protein.

*Technical and economic details.* The protein is produced by extrusion cooking of extracted soya bean flour and other oil-seed cakes and can be used as a partial substitute for meat in food products. The advantages of this product are full use of oil-seed cakes, good organoleptic quality and good nutritive value.

*Status of commercialization.* The process is commercially applied.

#### Contact address

Instituto de Investigaciones Tecnológicas,  
Avenida 30 No. 52-A-77, Bogota, Colombia

### Preservation of fish

*Description.* Low-cost process for preservation of fish.

*Technical and economic details.* The split fish are buried in salt until the body fluids form a brine liquor. At 30°C, 72% relative humidity, the climatic conditions can be used for the salting/drying process. If relative humidity is high (85-90%), salting is followed by drying. The product is sealed in polyethylene film bags and has a storage life of three months at 25°C and 85% relative humidity.

*Status of commercialization.* The process is commercially applied.

#### Contact address

Instituto de Investigaciones Tecnológicas,  
Avenida 30 No. 52-A-77, Bogota, Colombia

### Coconut cherry cubes

*Description.* Technology for processing of coconut milk.

*Technical and economic details.* The product is a delicious dessert manufactured from waste coconut water using a bacterial culture. It is syruped in sugar as cubes ½ in. in size and could be flavoured and coloured to suit different markets. The Industrial Development Board has developed simple ways of preparing this on a cottage scale in order to popularize this as a home industry.

*Status of commercialization.* Ready for commercialization.

**Contact address**

Industrial Development Board of Ceylon (IDB),  
615 Galle Road, Katubedde, Sri Lanka

**Manufacture of tomato purée**

*Description.* Low-cost process for preparation of tomato purée.

*Technical and economic details.* The process for preparation of purée consists of removing the seeds, skins and hard cores from the ripe tomatoes that have been treated by hot-break method, and concentrating the tomato pulp to not less than 9.0% solids free of salt. The purée is filled hot into plain A-2½ cans and sealed. The sealed cans are processed at 100°C for 25 minutes. By processing 1.5 tons of tomato fruits per day in one shift of 8 hours for 100 working days one can produce 70,000 A-2½ cans of tomato purée. Depending on demand the production can be increased threefold by operating three shifts and providing other inputs. The total capital investment amounts to Rs 520,000. The production will employ 10 workers and supervision/managerial personnel.

Important items of equipment are washing tanks, steam-jacketed kettles, pulper, filling machine, seamers, retort and boiler. The cost of production can be reduced further if the seed can be utilized for sowing purposes. This will call for preservation of the seed viability during crushing; only cold processing of the fruit can ensure this aspect. The machinery required can be fabricated in many countries with minimum workshop facilities.

*Status of commercialization.* The process is commercially applied.

**Contact address**

Central Food Technological Research Institute,  
Cheluvamba Mansion, Food Technology P.O.,  
Mysore 570013, India

**Canned coconut milk (Gata)**

*Description.* Production and canning of coconut milk.

*Technical and economic details.* Coconut cream or "gata" is the white extract of the ground coconut meat. It is rich in vegetable fat and used for culinary and baking purposes in the tropical countries. The procedure for producing canned coconut cream is as follows. Mature and sound dehusked coconuts are cracked and then deshelled. The coconut meat is then washed, weighed and ground. The ground meat is then passed through an expeller to extract coconut whole milk. The first extract is pure coconut whole milk. The ground coconut meat (after the first extraction) is then mixed with one half to two times

its weight of water and then passed through a screw press. This second extract is centrifuged whereby the cream is separated from the watery and solid portions. The cream is then mixed with one half to two times its weight in water and pasteurized for about 15-30 minutes. The pasteurized cream is mixed thoroughly with a stabilizer and passed through a homogenizer for further blending. The homogenized mixture is heated almost to boiling, poured hot in tin cans, immediately sealed and sterilized at 6-10 psi for 45-70 minutes.

*Status of commercialization.* Semi-pilot-scale production.

**Contact address**

National Institute of Science and Technology,  
P.O. Box 774, Manila, Philippines

**Production of a carbonated beverage from guava fruit**

*Description.* Processing of guava fruit into a beverage as a substitute for carbonated beverages that are based on imported components.

*Technical and economic details.* The process involves washing of fruit, comminuting, pulping, clarification and carbonation steps. The major pieces of equipment required are: washing baskets; comminuting machine; pulper; filter press; carbonation/bottling plant.

Capital investment is estimated at Zambian kwacha 40,000 for equipment, excluding building.

*Status of commercialization.* Ready for commercialization.

**Contact address**

National Council for Scientific Research, P.O.  
Box CH 158, Chelston, Lusaka, Zambia

**Pectin, oil and calcium citrate from limes**

*Description.* Process for extracting pectin, oil and calcium citrate from limes.

*Technical and economic details.* The process consists of crushing the fruits, pressing, distillation of juice to recover the oil, precipitation of calcium citrate from the juice under controlled conditions and manufacture of pectin from the waste peels. The process for pectin manufacture consists of extraction of peels in acidified water under controlled conditions of temperature and pH, filtration of the extract, precipitation of pectin as aluminium pectinate, chemical treatment of the precipitate to free pectin concentrate from aluminium, precipitation of pectin with ethyl alcohol, and drying.

Production capacity:	600 tons of fruit per season (150 days)
	1.8 tons oil
	24 tons calcium citrate
	14.5 tons pectin (150 grade)
Fixed capital:	Rs 1,250,000
Working capital:	Rs 250,000
Cost of production (approx):	Oil, Rs 80/kg

*Status of commercialization.* The process is commercially applied.

#### Contact address

Central Food Technological Research Institute,  
Cheluvamba Mansion, Food Technology P.O.,  
Mysore 570241, India

#### Production of weaning food

*Description.* Preparation of weaning food from oil-seed flours, pulse flours and cereal flour.

*Technical and economic details.* Weaning food is prepared by blending the oil-seed flours such as ground-nut or soya bean and pulse flours such as green gram, Bengal gram or black gram with cereal flour. The steps in the manufacture are: pre-cleaning and powdering the raw materials, blending of flours, dispersing and pre-cooking the blend in water, roller drying and packing. The food contains 28% protein and is useful for feeding weaned infants, and also as a supplement to the diets of schoolchildren and adults.

Production capacity:	3 tons per day
Fixed capital:	Rs 3,200,000
Working capital:	Rs 2,000,000 (3 months)
Cost of production:	Rs 9 per kg

*Status of commercialization.* The process is commercially applied.

#### Contact address

Central Food Technological Research Institute,  
Cheluvamba Mansion, Food Technology P.O.,  
Mysore 570241, India

#### High-fructose corn syrup production

*Description.* Process for production of high-fructose corn syrup by means of glucose isomerase. The product is used as sugar substitute.

*Technical and economic details.* Being a micro-biological enzyme, glucose isomerase is obtained from the cells of *Streptomyces sp.* No. 14 (KFCC 35051), which is a newly isolated strain. The cells are cultured in a medium containing xylose or xylan to induce the enzyme. The cells thus grown can be harvested and used as crude enzymes.

The consumption of high-fructose corn syrup will significantly reduce growth rates of imports by providing a domestic sugar substitute. Consequently, the development of glucose isomerase for the production of high-fructose corn syrup is anticipated to bring about the double advantage of food technology development and foreign exchange savings. In addition, the research team is investigating methods of producing immobilized enzyme and developing the continuous isomerization process, since the production of high-fructose corn syrup is gradually being shifted to the continuous process.

*Status of commercialization.* The process has been commercially applied since 1976.

#### Contact address

The Korea Institute of Science and Technology  
(KIST), P.O. Box 131, Dongdaemoon, Seoul,  
Republic of Korea

#### Improved method for manioc processing

*Description.* Process that reduces the toxic factors in manioc by 35%, yielding a detoxified dried chip which can be stored and, if necessary, processed into flour.

*Technical and economic details.* The process has eight stages: 1. Peeling; 2. Chipping; 3. Sun drying I; 4. Soaking and washing the chips; 5. Sun drying II; 6. Oven drying; 7. Grinding and sieving; 8. Packing.

The first three stages may be carried out at the factory or decentralized in households. In the latter case the factory has to buy dry chips instead of raw manioc. For the production of industrial flour, stage 6 is omitted. Provided the water used is bacteriologically satisfactory and the processing hygienic, the product may be used for food purposes, e.g. as a part-substitution for cereal flours. In industry the flour is suitable for preparation of dextrins and other adhesives. Its suitability for textiles is being studied. The main wastes of the process will be the rind and the soak water. Drying, soaking and re-drying of the rind followed by grinding will yield a product that can be used as poultry or cattle feed. Because of its high oxygen demand as well as high cyanide content, the soak water should not be discharged into the environment without further treatment.

For processing 400,000 lb of raw manioc per year the following requirements would have to be met: over 200 sunny working days with only one wet season a year; 2,400 gallons of potable water per day; 1,100 square feet of drying floors and buildings; 2,000 lb of fresh manioc per day or an equivalent in home-dried chips. Two hundred pounds of fresh manioc render 700 lb of flour. The total capital cost for establishing a plant with a processing capacity of

2,000 lb of raw manioc per day amounts to Rs 90,000. This includes the land, the building and the drying area, the machinery, the water supply and the working capital (Rs 7,000). If all eight stages of the process are done in the factory, a labour force of 2 skilled and 25 unskilled workers is needed for the production of edible flour. A paper with more detailed information about the process is available.

*Status of commercialization.* The process is commercially applied.

**Contact address**

Ceylon Institute of Scientific and Industrial Research, P.O. Box 787, Colombo 7, Sri Lanka

**Solar grape drier**

*Description.* Simple and cheap technology for processing grapes into raisins.

*Technical and economic details.* The process has been adopted by INTEC/Chile on the basis of technologies from Australia and the United States of America. It includes a simple chemical pretreatment (with caustic soda) and a solar drier with a special structure of horizontal mesh. This technique is labour-intensive and can be utilized successfully in a warm (25°C) and dry climate.

Capital requirements for a plant with a capacity of 30 tons of grapes a year amount to \$75/ton.

*Status of commercialization.* This technology is commercially applied in Chile. Technological information may be forwarded free of charge.

**Contact address**

Corporación de Fomento de la Producción, Gerencia de Desarrollo, Casilla 667, Santiago, Chile

**Processing of cashew nuts**

*Description.* Small plant for roasting cashew nuts.

*Technical and economic details.* The plant is a small demountable unit with simple design. Only low capital investment is involved.

A technical report with details and drawings (TD 102.Fin.) and an explanation report of the Ministry of Rural Development are available.

*Status of commercialization.* In use in several plants.

**Contact address**

Technology Development and Advisory Unit, University of Zambia, P.O. Box 2379, Lusaka, Zambia

**Hand texturizer for food processing**

*Description.* Equipment to produce low-cost vegetable protein products at a village level: an alternative to extrusion cooking technology.

*Technical and economic details.* The equipment employs the same general functional consideration as the cooker extruder, i.e. temperature, pressure, time and moisture. The base plate and a plug-type lid are heated by a coal briquette fire or any other steady heat source such as charcoal or vaporized fuel oil. Where low-cost electricity is available an electric heater also can be used.

A predetermined quantity of the raw material is placed into a shallow, 10-cm diameter cylinder chamber located in the base plate. The lid is placed in proper alignment and pressure is applied to the mixture by a lever and plunger (the plunger mechanism employs an eccentric cam action actuated by the lever). The lever is then held down for the required time and at the appropriate pressure. When the lever is released, instantaneously the heated water within the mix explodes in vapour and puffs the product.

The products that could be produced by the texturizer may be divided into two main groups:

(a) Snack-type products produced from raw materials that are high in starch and low in protein (10-12% or less), such as rice, corn, sweet potato flakes and cassava flour. The product is expanded and can be eaten as it is;

(b) Meat-analogue-type products using raw materials high in protein content (20% or more) such as soy flour, peanut meal, glandless cotton seed flour etc. This type of product develops a meat-like texture which is less expanded. The product which is already cooked can be consumed after soaking it for several minutes in water which may contain salt etc., and then fried for a short time. Another possibility is to grind the product into flour or chunks and add it to various dishes before cooking, in order to increase their protein level.

The apparatus would cost about \$42 in a developing country and could easily be made in a small machine shop. It can produce products which cannot be obtained by using an extruder cooker (e.g. structured vegetable proteins with a high fat content). The hand texturizer requires little skill to operate. Almost any raw material having a range of 20-60% moisture can be used. A detailed handbook is available from VITA, 3706 Rhode Island Avenue, Mt. Rainier, Maryland 20822, USA.

*Status of commercialization.* Ready for commercialization.

**Contact address**

International Institute of Protein Food Technology (IIPFT), Meals for Millions Foundation, 1800 Olympic Boulevard, P.O. Box 680, Santa Monica, California 90406, USA

### Gari-processing machinery

*Description.* Equipment for processing of the Nigerian staple food, gari.

*Technical and economic details.* The equipment developed will enable mass production and therefore price reduction of this food. It consists of machinery for peeling, grating, de-watering, screening, gas-generation from coal and frying.

*Status of commercialization.* Patents have been obtained. Limited production has been taken up. Semi-mass production is being planned.

#### Contact address

Projects Development Institute, P.O. Box 609, Enugu, Nigeria

### Vinegar from coconut water

*Description.* Production of vinegar from coconut water (generator process) with the help of a bamboo generator.

*Technical and economic details.* The production process is as follows. Filter fresh coconut water through muslin cloth or coarse fabric, to remove large particles of suspended dirt, i. to a kettle. To 10 litres of this filtered coconut water dissolve 1.5 kg of brown sugar and then pasteurize for 20 minutes. Cool and transfer to the fermentation vessel. Add 5 g Fleischmann's yeast. Allow this solution to ferment until the vigorous bubble formation stops. This is the alcoholic solution.

To start vinegar production, close the air inlet of the vinegar generator and trickle down 4 litres of actively fermenting vinegar or laboratory-prepared inoculum into the generator for 3 days. The vinegar generator consists of a bamboo column about 8.5 cm inside diameter and 2.3 m high, packed with 0.85 kg of moist coconut coir fibres. Decant or siphon the upper layer of the alcoholic solution in the

fermentation vessel carefully, so as not to disturb the sediment at the bottom of the container. Transfer 10 litres of the solution into the reservoir or container placed on top of the previously inoculated vinegar generator. Trickle down or feed into the vinegar generator the contents of the reservoir at the rate of 0.75 to 1 litre per hour. Recycle the product collected at the bottom of the generator until an acidity of approximately 6% (total acidity) is obtained. See that the air inlet of the vinegar generator is fully open during the above operation. Pool the resulting clear vinegar and pasteurize or age and then pasteurize, depending on its intended use, prior to bottling.

*Status of commercialization.* Semi-commercial production.

#### Contact address

National Institute of Science and Technology, P.O. Box 774, Manila, Philippines

### Chamber for smoking fish

*Description.* Low-cost equipment for smoking fish.

*Technical and economic details.* The chamber can hold about 100-300 lb of fish depending on the variety and size of the fish. The total cost of the unit does not exceed Rs 500 and the product obtained is of very high quality.

The fish are hung on pieces of wire in a wooden smoke chamber into which smoke, produced by a smoke generator, is introduced.

*Status of commercialization.* Ready for commercialization.

#### Contact address

Industrial Development Board of Ceylon (IDB), 615 Galle Road, Katubedde, Sri Lanka

## VI. Agricultural machinery and implements

### Mochudi toolbar

*Description.* Multi-purpose agricultural machine ("Makgonatsotlhe").

*Technical and economic details.* To the ox-driven toolbar almost any type of cultivation tool can be attached and it can also be used for carting or transporting drums of water.

The multi-purpose machine consists of an iron frame on two wheels and several implements. The full range of implements are carried on transverse subframes which clamp on to the edge of the angled iron frame. Since subframes can be positioned anywhere along the width of the frame, either one or two planter units may be used at row widths varying from 75 cm to 100 cm. Other tools can likewise be positioned as desired. All of the bolts used in assembly and adjustment of the components are the same size, 12 mm, so that only one size spanner is required.

The frame of the toolbar can be raised and lowered according to the working depth required. A planter unit incorporates the seed-metering drum, the seed-press wheel, the chain drive and an open drag. The fertilizer applicator consists of a metering device and subsoiler shank with a tube extending down the back to deliver the fertilizer deep into the soil. The unit is designed so that it can be used in combination with the planter. The disk hillers may be used both for throwing away the soil from the plants and for ridge building. Full sweeps may be fitted for stubble mulching. With the tool frame in full-down position it is at a very convenient height for carrying water drums or other goods. By fitting floor boards and sides the toolbar becomes a scotch cart capable of carrying 500 kg. A walking implement can be assembled which can be used for inter-row cultivation.

As well as being extremely versatile, the toolbar incorporates a number of additional features that aid crop productivity and quality. The toolbar will:

- (a) Reduce soil erosion through maintaining the crop residues as a surface mulch;
- (b) Conserve moisture also by leaving the surface mulch and tilling only the top 10 mm of soil;
- (c) Control weeds with the use of the Texas-style sweeps in combination with disk hillers;
- (d) Increase germination and reduce seedling mortality. (A lister share ahead of the planter will allow the seed to be placed in the moist soil.);

(e) Imbed the seed firmly in moist soil before covering with the seed-press wheel;

(f) Make better use of fertilizer through applying the fertilizer below the seed when planting.

A report and a complete set of drawings are available.

*Status of commercialization.* The toolbar has been used in Botswana since 1973.

#### Contact address

Mochudi Farmers Brigade, Box 208, Mochudi, Botswana

### Mini thresher

*Description.* Small thresher for dwarf paddy varieties and wheat.

*Technical and economic details.* The machine consists of a threshing cylinder based on the axial flow principle. It is lightweight and is mounted on two wheels for easy transport. A two-man crew is needed for feeding the machine and for transporting bundles to it. It is powered with a 5-hp kerosene or 3-hp diesel engine.

Threshing output per hour: Wheat, 280 lb  
Paddy, 560 lb

Price of the thresher: Rs 6,500  
without engine

*Status of commercialization.* May be ordered from producer.

#### Contact address

Bethlehem Technical Foundation (Trading), P.O. Box 435, Rawalpindi, Pakistan

### Machine for decortication of sesame seed

*Description.* Very effective method for decortication of sesame seed.

*Technical and economic details.* Simple labour-intensive process requiring a capital investment of Rs 20,000.

*Status of commercialization.* Ready for commercial exploitation.

#### Contact address

Ceylon Institute of Scientific and Industrial Research, P.O. Box 787, Colombo 7, Sri Lanka

### Rice thresher

*Description.* Machine for threshing rice and similar dry plants.

*Technical and economic details.* The machine is driven either by pedal or by bicycle. The frame of the machine is wooden. The model is the adaptation of a Chinese thresher. The conditional use for dry ground-nuts or soya beans is possible.

Productivity is 35 kg/hour (with pedal) and 60 kg/hour (with bicycle). The threshers are sold by CENEEMA for CFAF 20 000 (with pedal) and CFAF 25,000 (bicycle driven), respectively.

*Status of commercialization.* The machine is commercially produced.

#### Contact address

Centre national d'études et d'expérimentation du machinisme agricole (CENEEMA), B.P. 1040, Yaoundé, United Republic of Cameroon

### Corn sheller

*Description.* Very simple tool for manual corn shelling.

*Technical and economic details.* There are four types available at a price of CFAF 100-300. The productivity of the tool is 10-20 kg/hour.

*Status of commercialization.* The tool is produced and may be bought.

#### Contact address

Centre national d'études et d'expérimentation du machinisme agricole (CENEEMA), B.P. 1040, Yaoundé, United Republic of Cameroon

### Maize sheller

*Description.* Simple hand-held tool for removing maize from the cob.

*Technical and economic details.* The equipment is made from hardwood and can be produced at the village level with simple tools. In use the cob is inserted, tip first, into the central hole and rotated with a screwing motion. This removes the grain from the cob without damaging or cracking it and without breaking up the cob itself. The grain produced by this method has very little chaff and is easily winnowed to clean it. Where maize cobs vary in size, for example if both local varieties and hybrids are grown, it may be necessary to make two shellers of different size to cope with large and small cobs. Detailed information is available on request.

*Status of commercialization.* The maize sheller is used in rural practice.

#### Contact address

Tropical Products Institute, 56-62 Gray's Inn Road, London WC1X 8LU, United Kingdom

### Mini rice mill

*Description.* Small machine for rice milling.

*Technical and economic details.* The unit consists of paddy cleaner, sheller, separator and polisher. The sheller is of a centrifugal type and is more suited for milling mixed paddy varieties and fresh paddy with higher moisture content. The bran obtained is pure and has a high oil content. The equipment requires very little space for installation and can be installed in paddy-growing areas.

Operating capacity:	500 kg of paddy/hour
Cost of the unit:	Rs 30,000
Size of unit:	6 ft x 4 ft x 12 ft
Processing cost of paddy:	Rs 35/ton

*Status of commercialization.* Process is applied commercially.

#### Contact address

Central Food Technological Research Institute, Cheluvamba Mansion, Food Technology P.O., Mysore 570241, India

### Maize mill

*Description.* Small machine for processing maize.

*Technical and economic details.* Maize, both white and yellow varieties, can be processed into products such as grits, flour, bran and germ fractions using suitable dry-milling techniques. The maize mill, developed at CFTRI, consists of precleaning, destoning, conditioning, degerming and grinding operations.

Capacity:	400 kg of maize/hour
Fixed capital:	Rs 125,000 (for plant and equipment)
Processing cost:	Rs 68 per ton

*Status of commercialization.* Blueprints of the prototype design are available.

#### Contact address

Central Food Technological Research Institute, Cheluvamba Mansion, Food Technology P.O., Mysore 570241, India

### Solar-energy-powered crop sprayer

*Description.* A herbicide or insecticide sprayer powered by the sun, using silicon photo-voltaic cells and a battery of nickel cadmium cells.

*Technical and economic details.* The photo-voltaic generator comprises a panel, about 33 cm<sup>2</sup>, equipped with 38 semicircular silicon cells, 7.5 cm in diameter, connected in series, to deliver about 6 W at 12-14 V. Cells are rated at a conservative 100 mW/cm<sup>2</sup> light intensity to deliver, each, 500 mA at 0.45 V. The panel is protected by a blocking diode. It also serves as a sunshade for the operator and only weighs 1.2 kg. Eight nickel cadmium cells in the handle of the sprayer are series connected and at full charge deliver 1.2 V each (total 9.6 V) with a capacity of 4.0 A. They function both as a voltage stabilizer, maintaining a constant 7,000 rpm, and also to store the considerable excess power generated by the panel during periods of medium to bright sunlight

(3-6 W) over the requirements of the motors in the sprayers (0.8-2 W). After continuous operation for 8 hours a day, 7 days a week, the batteries were found to be as full of charge as on the first day.

The advantages of this technology lie in the light weight of the equipment, the reduced quantity of chemical solution necessary (15 litres per hectare instead of some 500 litres) and in the fact that no labour for pumping the sprayer is required.

*Status of commercialization.* No details provided.

*Contact address*

International Institute of Tropical Agriculture (IITA), Ibadan, Nigeria



## VII. Light engineering and rural workshops

### Blacksmith bellows

*Description.* Low-cost method for making a blacksmith bellows.

*Technical and economic details.* A step-by-step manual teaches the construction of bellows made with local materials, such as inner tubes of normal car tyres, plywood, nails and pieces of thin sheet metal. Flaps of simple rubber (from inner tubes of tyres) work as valves. The bellows are hand-operated and cost about \$3.

*Status of commercialization.* Bellows constructed according to this method are in use. The design may be used by all persons interested.

#### Contact address

South Pacific Appropriate Technology Foundation, P.O. Box 6937, Boroko, Papua New Guinea

### Wooden lathe

*Description.* Wooden lathe for the manufacture of wooden articles.

*Technical and economic details.* The machine can be used for sanding, drilling, line painting, hot ironing, lacquering and polishing. It can handle pieces of wood up to 95 cm long and 30 cm in diameter.

The lathe is formed by two pairs of legs, the bed and the strut. The headstock is of rigid construction with a 50-, 75- and 100-mm diameter pulley. A standard shaft with a No. 1 tapered hole in each side permits the use of different standard attachments such as faceplates, chucks etc. In each side of the headstock, one sealed, self-aligning ball-bearing is bolted with 8-mm bolts.

The tailstock supports the long tool-rest without interfering with its movement. It runs along the entire bed and is held down in position with a wing nut.

The moving system uses a flywheel made from cast iron because its weight makes the movement smooth and constant and this material is suitable for setting the bearings. The manufacture of this flywheel is possible in many villages. The pedal is of the rocking type and it is 1 m long, permitting working along the entire bed of the lathe.

The headstock and the bed must be made of hardwood. The lathe can be operated by human power but also by a 1½-hp motor when available.

*Status of commercialization.* Ready for commercialization.

#### Contact address

Central School of Art and Design, Mexico City, Mexico

### Driven tube-well

*Description.* Simple and effective tube-well consisting of a piece of perforated pipe with closed and pointed end.

*Technical and economic details.* The perforated pipe is driven down into the ground. An unperforated tube is screwed on top and that is driven down too. The process is repeated until the perforated end has entered and penetrated the aquifer to the desired degree. A pump is screwed on the top and water is drawn up the tube itself.

The tubes usually are not smaller than 1¼ in. or larger than 2 in., though tubes up to 4 in. in diameter are occasionally used. The pipe sections are 3-5 ft in length; the perforated area usually extends only 1-1½ ft up from the point and consists of drilled holes of 3/16-in. or ¼-in. diameter.

It is reasonable to hope for yields of about 300 gallons per hour from a 1¼-in. tube-well and 800 from a 2-in. one.

Any kind of suction pump can be used, either drawing directly or from a pipe hanging down inside the tube-well. The usual size of a well is too small to take a deep-well type pump. In practice this means that the suction limit of a tube-well is about 20 ft.

The well has the advantage that water can only enter the tube through bottom perforations thus excluding polluted water from upper layers.

*Status of commercialization.* No details received.

#### Contact address

Intermediate Technology Development Group, Water Panel, 9 King Street, London WC2E 8HN, United Kingdom

### Boswell water pump

*Description.* Equipment for pumping water from medium-depth wells in conjunction with an imported pumping cylinder.

*Technical and economic details.* The pumping head equipment is an all-steel construction, except for wooden limit stops. The two main pivoting points have greasable bearings with toughened steel pins. The equipment is designed for pumping water up from 90 metres, using a 12-mm pipe pump rod and a 50-mm bore pumping cylinder. By adjusting the size of the pumping cylinder and lightening the pump rod, greater depths with smaller flow rate—or more shallow depths with larger flow rate—can be achieved. Maximum force on the pump rod end of the handle should not exceed 300 kg. The handle can be counter-balanced by filling it with concrete or by bolting on weights through a hole provided in the hand-held end.

The lifting sleeve, which can slide over a 38-mm pipe, is screwed into the top of the delivery pipe, and the well is then sealed against human and animal pollution. A watertight seal could be fitted to this 38-mm pipe, around the pump rod, allowing water to be pumped higher than the head equipment.

The equipment is mostly installed in remote areas where simple construction using locally available light machinery and materials, durability and ease of maintenance are key factors. In Addis Ababa the pump can be produced at a price of \$250.

*Status of commercialization.* Such pumps are installed in many areas of Ethiopia.

*Contact address*

Kale Heywet Development Programme,  
P.O. Box 4181, Addis Ababa, Ethiopia

### Cupola furnace for foundries

*Description.* Melting facility as a substitute for the low-shaft furnace in local foundries.

*Technical and economic details.* The cupola furnace (14-in. diameter), with an approximate melting rate of 750 kg/h, is suitable for small and medium-sized foundries. Because of its small diameter, its design must be sectional to facilitate maintenance of refractory lining after each run. To lower the cost of construction, the cupola has been simply designed and has no complicated facilities

such as hot blast or O<sub>2</sub>-enriched blast air. The capital investment hence includes only the design, construction and test run. The cupola furnace can be made locally at a low cost. It is easy to handle and maintain and it is suitable for foundries where large capital investment is not available.

Careful operational control coupled with an appropriate moulding technique and design allows good castings of high-grade metal quality such as ductile iron to be produced economically, as compared to the electric furnace where the price of electricity is costly.

*Status of commercialization.* This type of furnace, at present, is being used in iron foundries for the commercial manufacture of a variety of cast-iron products, such as machinery parts and components, that have been hitherto imported. The design and operational service are available to interested parties on the basis of research contracts.

*Contact address*

Applied Scientific Research Corporation of  
Thailand (ASRCT), 196 Phahonyothin Road,  
Bangkhen, Bangkok, Thailand

### Manufacture of matches

*Description.* Small-scale production unit to satisfy local demand for safety matches.

*Technical and economic details.* The production unit is planned to manufacture 7,200 boxes of matches per day and employ 8 full-time or 15 part-time workers.

Capital required per work-place is Rs 700 (a work-place in an automated plant costs Rs 90,000). The total production cost of one box of matches, including duty, is about Rs 0.126 in Pakistan. The fixed capital required for one unit with 15 part-time workers is about Rs 5,500.

*Status of commercialization.* Production has started in one plant.

*Contact address*

Government of Pakistan, Appropriate Technology Development Organization, 1-B,  
47th Street, F-7/1, Islamabad, Pakistan

## VIII. Oils and fats

### Fat liquors for leather processing

*Description.* Processes for the production of blends of emulsifying agents such as sulphated oils and neutral oils (vegetable, animal marine and mineral) that are used in the processing of leathers.

*Technical and economic details.* The Central Leather Research Institute has developed processes for the manufacture of fat liquors from indigenous oil sources such as sardines, coconut, castor etc. The processes envisage the sulphation of clarified oils of required specifications under standard conditions which vary with the type of oil for the specific types of fat liquors to be produced. The sulphated products are washed free of sulphuric acid and neutralized to the required pH. These are blended suitably with other oils and ingredients wherever necessary. Testing and quality control at different stages, starting from the raw-material stage, are essential to maintain the standard of the product. These standards have to be specifically adhered to so that tanners receive products of uniform quality.

*Status of commercialization.* Ready for commercialization.

#### Contact address

Central Leather Research Institute, Sardar Patel Road, Adyar, Madras 600020, India

### Silicone oils production

*Description.* Process to produce methylsilicone oils from dimethyldichlorosilane.

*Technical and economic details.* Dimethyldichlorosilane can be polymerized by hydrolysis to produce cyclic or linear dimethylpolysiloxanes with relatively low molecular weights. These silicone oligomers may be further polymerized by heating in the presence of acid or base catalysts. The molecular weights and viscosity of the silicone oils produced depend on the amounts of the chain-stopping agent, hexamethyldisiloxane, used in the catalytic polymerization reaction.

Silicone oils are very stable in heat and cold, very inert to chemical agents, and are thus used for a variety of industrial purposes; for example as dielectric fluid, hydraulic fluids, release agents, antifoamer and water repellants.

Silicone resin, silicone rubber, and semi-conductor silicone, besides silicone oils, are other products of the silicon chemical industry. The raw materials for the silicon chemical industry are silica, salt, and hydrocarbon, which are all readily available from domestic sources.

*Status of commercialization.* Ready for commercialization.

#### Contact address

The Korea Institute of Science and Technology, P.O. Box 131, Dongdaemoon, Seoul, Republic of Korea

### Synthetic pine oil from turpentine

*Description.* Process for the production of synthetic pine oil as an alternative source for scarce natural pine oil.

*Technical and economic details.* The process developed by the Shri Ram Institute for Industrial Research is a novel attempt to use local turpentine with a comparatively low pine oil content for the production of synthetic pine oil. In brief, the process consists of partially isolating the pine oil fraction, followed by reaction with alcohol in the presence of a catalyst. Since the plant was established by the licensee, Prabhat General Agencies, details about investment are available only from them.

*Status of commercialization.* The process has been under commercial production since 1960. The process is covered by Indian Patent No. 69344.

#### Contact address

National Research Development Corporation of India, 61 Ring Road, Lajpatnagar III, New Delhi 110024, India

### Integrated processing of sesame seed

*Description.* Production of edible oil and protein concentrate from sesame seed.

*Technical and economic details.* Commercial-quality sesame seed is cleaned. The cleaned seeds are chemically treated under optimal conditions, washed and decuticled. The decuticled seeds are expeller-

pressed to obtain edible oil and cake that could be processed to yield edible-grade sesame flour and protein concentrate.

Production capacity: 10 tons of raw  
material/day  
Fixed capital: Rs 2,900,000  
Working capital: Rs 1,350,000  
Cost of production: Rs 1,200/ton

*Status of commercialization.* The process is applied commercially.

*Contact address*

Central Food Technological Research Institute,  
Cheluvamba Mansion, Food Technology P.O.,  
Mysore 570241, India

### Oil from shark liver

*Description.* Process for the extraction of oil from shark liver and for the preparation of vitamin A concentrate.

*Technical and economic details.* During investigations on edible fish it was discovered that the oil of shark liver was several times richer in vitamin A than cod-liver oil. A process for the extraction of oil and the preparation of vitamin A concentrate was developed.

*Status of commercialization.* The process has been commercially used since 1962.

*Contact address*

Pakistan Council of Scientific and Industrial  
Research, Press Centre, Shahrah-e-Kamal Ataturk,  
Karachi 01090, Pakistan

### Substitution of diesel oil by vegetable oils

*Description.* Substitution of fossil fuels by renewable fuels.

*Technical and economic details.* Unrefined peanut oil can be used in diesel engines alone or mixed with mineral oils. Castor oil can be used with ethanol and an ignition additive. A technical report is available at IPT.

*Status of commercialization.* Ready for commercialization.

*Contact address*

Instituto de Pesquisas Tecnológicas do Estado  
de São Paulo S.A. (IPT), P.O. Box 71411,  
01000 São Paulo, Brazil

### Portable essential oil distillation unit

*Description.* Equipment to distil essential oil from leaves in mountainous areas.

*Technical and economic details.* The still is made of one and a half 200-litre oil drums welded together. The condenser is made of stainless-steel. The stove could be modified to use wood, spent hay, rice husk etc. This unit would cost about \$200 if manufactured in Thailand.

*Status of commercialization.* The product has been utilized commercially but there is no intention to apply for any patents or any other licences.

*Contact address*

Project Development Department, Applied  
Scientific Research Corporation of Thailand,  
196 Phahonyothin Road, Bangkok 9, Thailand

## IX. Paper products and small pulp mills

### Pulping of rice straw

*Description.* Techniques for the production of pulp from rice straw.

*Technical and economic details.* For the production of bleached pulp for fine paper it is essential to remove a substantial part of the non-fibrous cells and extraneous materials from rice straw. A new technique for efficient cleaning and upgrading of this raw material has been developed. This new technique, "the wet-cleaning" of rice straw, was first applied at the RAKTA Pulp Mill in 1961 and has been developed further since then. Over the past 13 years of mill experience, the wet-cleaning technique has proved the following advantages:

(a) An increase in the overall pulp yield by about 2%;

(b) A reduction in cooking chemical by about 2%, based on straw;

(c) A better use of the capacity of the digester by about 15% is achieved. Moreover, the packing of the digester is higher than when using dry straw;

(d) A reduction of the silica content of the straw due to the removal of a good part of the leafy and extraneous materials in the wet-cleaning system;

(e) The resulting pulp from the wet-cleaned straw has a higher freeness, which leads to easier washing of the pulp in ensuing processes such as the brown stock washers and bleaching washers;

(f) The wet-cleaning system opens up the straw, which makes the pre-impregnation with cooking liquor efficient;

(g) The removal of leafy and extraneous materials from the straw leads to better bleaching of the pulp; these materials would have consumed bleaching chemicals uselessly. About 15% of the chlorine consumed in the bleaching process is saved by introducing the wet-cleaning system;

(h) The strength properties of the pulp are appreciably improved.

A short-cycle pulping process (3 hours at 7 atm) resulted in raising the production capacity of the pulp mill. Another advantage of this process is that the pulp produces more opaque paper sheets because of the higher silica content retained in the pulp. This has led to a reduction in the fillers added in paper-making and to savings in hard currency needed to import such fillers. Consequently, the cost per ton of pulp is considerably reduced.

It has been found that these pulps differ appreciably in their dewatering property. The reed and bagasse pulps are much freer and drain more easily than rice straw pulp. By blending rice straw pulp with reed or bagasse pulp and studying the bleaching characteristics of such pulp blends the following results are obtained:

(a) Improving the dewatering property of rice straw pulp;

(b) Increasing the capacity of the bleach plant;

(c) Raising the efficiency of the pulp washers and thickeners;

(d) Reducing the bleach chemicals, water and power;

(e) Producing uniformly bleached pulp blends with better strength properties.

*Status of commercialization.* These techniques are applied on a commercial basis.

### Contact address

General Company for Paper Manufacturing (RAKTA), El Tabia, Alexandria, Egypt

### Pulp-making from rice straw

*Description.* A dilute ammonia process for making pulp from agricultural residues such as rice straw, bagasse and grass-family plants.

*Technical and economic details.* Existing processes for rice straw and agricultural residue are expensive because caustic soda and sodium sulphite are used which cannot easily be recovered and result in inevitable pollution if the wastes are indiscriminately discharged into rivers.

The new process developed in Malaysia is different in that ammonium hydroxide is used and digestion takes place in a pressurized vessel heated by coils carrying steam. Previous attempts of this type elsewhere had failed because concentrated ammonium hydroxide was used in the mistaken belief that it is a weak alkali at high pressure and temperatures. Actually, vapour pressure problems had prevented a workable temperature at safe pressures from being achieved.

This problem was solved by using dilute ammonia (2-7%) together with catalytic agents which permitted temperatures of 140°-150°C to be reached at pressures of 150-200 psi. Cooking time under these

conditions is less than 1 hour, compared to 15 hours previously.

Straw or bagasse is cut, washed and fed to the digester and a solution of ammonium hydroxide is filled into the digester and heated under pressure. The non-fibrous materials such as lignin and carbohydrates dissolve or swell up into jelly. After the digestion the pressure is released through a recovery unit for collecting the ammonia and the digester is put under vacuum until no ammonia remains. The pulp, now free from ammonia, is run out into washers, refiners, bleachers and other specialized plant before being made into sheets. If a paper plant is adjacent to the pulp mill, the pulp is mixed with various fillers, sizes, waterproofing compounds and pumped into the paper-making section for conversion to paper. Black liquor wastes are evaporated to dryness and used as fuel or sold for various purposes.

The new ammonia pulping process provides these advantages:

(a) Cost of pulp production is low compared with conventional chemical processes because of the recovery of the ammonia;

(b) Cellulose fibre is not affected by ammonia and therefore the pulp is much stronger than soda and sulphate pulp;

(c) Variation of yield of pulp is obtained by adjusting the ammonia concentration and cooking time: reduced boiling time gives a large yield by partial removal of lignin etc.;

(d) The lignin-rich residual black liquor normally available in this process contains a higher concentration of solids, and requires less heat to evaporate to dryness;

(e) Ammonia does not attack any silica in plant tissues or entrained silica; hence, evaporation of black liquor is straightforward;

(f) If the digestion temperature is low and the raw materials are cereal straws or grasses, the evaporated residues from the black liquors are so pure that these can be used as animal feed additives;

(g) The lignin residues also may be utilized as fuel, fertilizer, plastic filler, wood adhesives, base for alcohol manufacture and other purposes, solving the problems of disposal and attendant pollution.

*Status of commercialization.* The process is covered by patents in several countries while in other countries patents are pending.

#### Contact address

Industrial Patents (M) Sdn. Bhd., 905A Ene Plaza, 128 Jalan Pudu, Kuala Lumpur, Malaysia

#### Use of *Agathis lorantifolia* for paper pulp

*Description.* Use of the softwood species, *Agathis lorantifolia*, as raw material for paper pulp.

*Technical and economic details.* The sulphate process and C-E-H-H bleaching sequence was used during the investigation. The pulping behaviour was relatively good, with a rather low yield (44-48% pulping yield) and the physical properties were comparable with other softwood species like *Pinus merkusii*.

*Status of commercialization.* This process has been utilized commercially in a paper mill. No patents have been obtained yet.

#### Contact address

Lembaga Penelitian Selulosa (Cellulose Research Institute), Jln. Raya Dayeuhkolot 158, Bandung, Indonesia

#### *Dacridium* spp. for pulpwood

*Description.* Utilization of *Dacridium* spp. for pulpwood and for manufacturing paper for cement bags.

*Technical and economic details.* *Dacridium* spp. as a softwood (average fibre length 5.47 mm) is a potential species for reforestation in South Kalimantan. Research was done to study its suitability for manufacturing wrapping paper as well as kraft paper for cement bags. Laboratory as well as pilot-plant-scale studies were carried out using sulphate process. It seems that with adequate refining, a strong wrapping paper could be produced which is comparable with kraft paper for cement bags.

*Status of commercialization.* This process has been applied commercially at a paper mill to produce wrapping paper.

#### Contact address

Lembaga Penelitian Selulosa (Cellulose Research Institute), Jln. Raya Dayeuhkolot 158, Bandung, Indonesia

#### *Eucalyptus saligna* for dissolving pulp and its viscose rayon making

*Description.* Utilization of *Eucalyptus* species for dissolving pulp and its viscose rayon making.

*Technical and economic details.* Experiments were carried out using the sulphate process preceded by water prehydrolysis; they gave a relatively good pulp yield with low pentosan content, but with a rather high ash content. The dissolving pulp obtained is comparable to imported dissolving pulp. Rayon stable fibre was made from it and no significant problem arose during the spinning.

*Status of commercialization.* This process has not been utilized commercially since no rayon industry exists in Indonesia. No patents have been obtained yet.

**Contact address**

Lembaga Penelitian Selulosa (Cellulose Research Institute), Jln. Raya Dayeuhkolot 158, Bandung, Indonesia

**Use of rubber tree for pulp and paper**

*Description.* Utilization of old rubber trees for pulpwood for manufacturing writing and printing paper.

*Technical and economic details.* As the rubber tree (*Hevea brasiliensis*) contains latex, problems arise during the pulping process, i.e. clogging on the screens etc. The sulphate process and soda-sulphur process were used in this investigation, although any process containing sulphur can be used. The latex was not sticky and the removal by screening became easier.

*Status of commercialization.* This process has been utilized commercially in a paper mill for the production of duplicating paper (cyclostyle). No patents have been obtained yet.

**Contact address**

Lembaga Penelitian Selulosa (Cellulose Research Institute), Jln. Raya Dayeuhkolot 158, Bandung, Indonesia

**Paper pulp moulding system**

*Description.* System for the production of paper pulp moulds such as egg trays, egg boxes, meat trays, seed pots, wine bottle packs, fruit trays etc.

*Technical and economic details.* This technology has been developed by Development Techniques (the

engineering subsidiary of Intermediate Technology Development Group Ltd., London) and the commercial company Tomlinsons (at present, sale licensee).

The process consists of the following steps:

1. A pulp preparation machine breaks the paper down into its constituent fibres and disperses them uniformly in water together with small quantities of soluble wax and aluminium sulphate.
2. At this stage the moulding machine immerses a forming mould into the pulp and by vacuum draws water through the mould to leave a mat of fibres on its surface. The water is recycled to be used again in the preparation of more pulp.
3. The wet moulding is removed from the forming mould by means of a transfer mould using vacuum and compressed air.
4. In the final stage of the process the excess water is removed by a drying machine.

The hot-air drying system gives controlled drying of the mouldings. The air is heated by steam, electricity, gas or oil. The drying system is designed to recirculate up to 90% of the air and is thus very efficient in the use of fuel.

The small-scale equipment produces from 180 30-egg trays per hour up to 2,000 30-egg trays per hour according to packaging needs and the corresponding type of machine. As raw material, clean newspaper can be used.

*Status of commercialization.* A licence has been issued. A transfer of its manufacture under an agency (and, ultimately, a licensing) arrangement to India and Brazil is being negotiated.

**Contact address**

Tomlinsons (Rochdale) Ltd., Newhey Road, Milnrow, Rochdale, United Kingdom

## X. Energy for rural requirements

### Bicycle-powered water pump

*Description.* A commercially available water pump driven by a single vee belt from the bicycle-wheel rim.

*Technical and economic details.* The advantages of this pump are its simple and solid construction, the fact that no energy is required and its low cost. It is able to pump more than 3 gallons per minute at vertical distances up to 50 ft.

The pump has also been successfully tested using a small ½-hp overshot water-wheel for power.

*Status of commercialization.* This technology is being used.

#### Contact address

Pindiu Rural Development Association, Pindiu, Morobe Province, Papua New Guinea

### Diaphragm pump

*Description.* Water pump for low-lift irrigation.

*Technical and economic details.* The pump is a foot-operated, paddle system with discharge of 55-60 gallons/min at maximum head of 6 ft. It consists of a mild-steel cylinder, divided into two chambers with inlet and exhaust valves, mounted on a wooden frame. The price is about Rs 1,200.

*Status of commercialization.* May be ordered from producer (see contact address).

#### Contact address

Bethlehem Technical Foundation (Trading), P.O. Box 435, Rawalpindi, Pakistan

### Diaphragm pump

*Description.* A pump for lift irrigation.

*Technical and economic details.* The pump is relatively light and can be manually carried for field operations. Important features of this pump are design and fabrication simplicity, a 50-60 gallon capacity under low-lift conditions and manual operation. Preliminary tests carried out by the Industrial Development Board with the prototype

gave good results, showing that an average person could pump 50-60 gallons of water per minute at 6-8 ft of water head. The pump's circular rubber diaphragms are not subjected to excessive stress and it is expected that they will have a satisfactory service life. The pump can handle muddy water with small solid impurities without any problems.

*Status of commercialization.* Ready for commercialization.

#### Contact address

Industrial Development Board of Ceylon (IDB), 615 Galle Road, Katubedde, Sri Lanka

### Hydraulic ram pump

*Description.* Pump without motor, actuated by the water itself.

*Technical and economic details.* The pump is made of simple galvanized-iron pipe fittings and has been developed by the South Pacific Appropriate Technology Foundation. It has very few moving parts and construction requires only hand tools and a drill press. No special skills, e.g. threading, machining, brazing or welding, are required.

This device can pump several thousand litres of water a day over long distances and up to heights of 50 metres or more using the energy of falling water. The construction is described, step by step, in a manual. It would cost about K 40 to build this pump in Papua New Guinea.

*Status of commercialization.* Ready for commercialization.

#### Contact address

Appropriate Technology Development Unit, P.O. Box 793, Lae, Papua New Guinea

### Hydropower for rural development

*Description.* Technology for small-scale hydroelectric power generation (10-100 kW).

*Technical and economic details.* The Intermediate Technology Development Group (ITDG) and a private company have developed new concepts and construction techniques that offer savings in small



turbine construction. At present pilot plants can be offered using either propeller turbines for heads of water from 2 to 10 m. or impulse turbines for heads in excess of 20 m. A turbine for the intermediate-range heads is being developed.

One of the innovative features of this system is the use of load control. The turbine is set to carry the full water flow; any surplus electrical power is stored in a bank of electrical resistors that are capable of absorbing even the full output of the alternator should no electrical power be needed. Modern electronic switching devices can make adjustments for any change in demand quickly; however, load control switching can even be manual.

Because there is no need to vary the water supply (as with flow control), much simpler turbine designs can be used—without gates, variable pitch blades or adjustable automatic valves—and there is no need for a mechanical controller to automatically adjust valves.

An electronic load controller needs nearly no power for switching, requires no maintenance and costs from £200 to £1,000 depending on rating and number of output phases. It is less expensive to install, is inherently more reliable and has the potential to deliver more usable power from a given system if the load can be split between a primary demand circuit and a secondary by-product circuit. Load control does require that the alternator runs continuously at full power, but, as it is normal to use a larger frame size than in an equivalent engine-powered system, it is possible to ensure a very long life (over 30 years) with only occasional maintenance. The extra cost of installing the larger alternator can be recovered through the long amortization period.

A simple but effective Pelton wheel impulse turbine using load control has been developed for heads of water over 20 m. It can be two or three times as powerful as a turbine with a spear valve which is needed with flow control. The Evans/ITDG load controller consists of a Triac electronic switching circuit (one per phase of output is required) used in combination with a suitable ballast load circuit capable of absorbing surplus electrical power. Two or three nozzles (or even four) can be used, giving proportionate increases in flow. The nozzles can be manually switched in or out, by using simple gate valves, to allow for seasonal changes in flow.

As low- and medium-head turbines, propeller turbines have been adapted and an upward-flow turbine with a vertical shaft proved to be the most favoured configuration. A turbine is being developed to replace the Francis Turbine for use on heads from 10 to 20 m. It will use a similar flow path to the Turgo wheel but it runs partly as a reaction turbine.

ITDG is independently developing a device that operates on zero head of water and utilizes the kinetic energy of a river's current. The machine is more like a windmill than a traditional turbine as it is

not encased but runs in free-stream either supported by a pontoon or sunk on to the bed of the river.

Turbine construction should require only commonly available machine or welding-shop facilities. However, it would probably be more economical, initially, to import the alternator, control equipment and other electrical components.

*Status of commercialization.* The propeller turbine system and the controller were both successfully installed in plants in the United Kingdom and in some developing countries. ITDG is looking for opportunities for joint projects in developing countries.

#### Contact address

Intermediate Technology Development Group Ltd., 9 King Street, London WC2E 8HN, United Kingdom

#### Low-grade heat-recovery turbopack system

*Description.* Turbine working on acetone-based rankine loop, with a turbine entry temperature of 60°C. Heat may be delivered by waste heat from industries, chemical plants, geothermal energy or solar energy.

*Technical and economic details.* This technology permits the use of energy at a low-temperature level, e.g. solar energy, and therefore may be used in rural areas. The system has a low power rating of 1-6 kW. Acetone, which is easily available in India and is non-toxic and non-corrosive, is used as working fluid.

The rankine cycle is operated around atmospheric pressure to simplify shaft sealing problems and to reduce disc friction loss at high speed.

One variant of the turbopack runs at 3,000 rpm, directly driving a pump or an alternator and thus eliminating belt-gearing. The design, which provides for almost hermetic sealing of the working fluid and also drives a condensate pump impeller mounted on the same shaft, is expected to offer long life, reliability and easy maintenance even in rural areas.

The estimated cost of this system is Rs 15,000 per installed kW. Assuming that heat is available continuously in the form of hot water or steam at a temperature of about 80°C, and assuming that production is 80% of available capacity per year and that depreciation, interest and maintenance will be about 20% annually, such a system will produce electrical energy at a cost of Rs 0.50 per kW.

The cost of the system using solar energy will be governed by the cost of flat-plate solar collectors.

*Status of commercialization.* Ready for commercialization.

#### Contact address

National Aeronautical Laboratory (NAL), Bangalore, India

### Windmill for irrigation

*Description.* Cheap and simple windmill for subterranean water pumping for irrigation.

*Technical and economic details.* The pumping equipment has been designed to allow for simple manufacture with cheap materials. The windmill has a sail diameter of 4.5 m and a pumping capacity of 60 m<sup>3</sup>/day at a wind speed of 8 m/sec during 4-5 hours/day. The estimated cost is \$1,000 per irrigated hectare.

The technology has been developed by INTEC/Chile for small farms.

*Status of commercialization.* The technology is being tested at the pilot level and will be forwarded to interested persons free of charge.

#### Contact address

Corporación de Fomento de la Producción,  
Gerencia de Desarrollo, Casilla 667, Santiago,  
Chile

### Solar wind-ventilated drier

*Description.* Solar-powered drier for grains, vegetables etc.

*Technical and economic details.* This technology was based on development work carried out in other countries. It consists of a wind-powered suction fan and a solar collector connected to a drying chamber with six mesh shelves, each 4 ft x 3 ft in area. The drier could be used for grains, vegetables, fruits and fish, making it possible to preserve the excess food produced in villages at a very low cost.

*Status of commercialization.* Ready for commercialization.

#### Contact address

Industrial Development Board of Ceylon (IDB),  
615 Galle Road, Katubedde, Sri Lanka

### Gobar gas plant

*Description.* Modified Chinese-type biogas plant providing gas and fertilizer slurry.

*Technical and economic details.* The advantage of the plant lies in the easily available raw material (dung) and, therefore, in the very low running costs (see figure). The gas storage chamber can be from 10 to 100 m<sup>3</sup> and its production requires no special skills. It is mainly made of bricks and cement. A plant of 10 m<sup>3</sup> with a daily production of 3 m<sup>3</sup> of gas covers the basic needs of one family. Five head of cattle are required for the production of the necessary dung. The fixed construction costs (bricks, cement, sand, gas pipes, burners, labour, technical assistance etc.) are about Rs 3,000. The total annual costs (equipment and running costs) are about Rs 500. The medium lifespan of the plant is 30 years.

*Status of commercialization.* Several plants of this design are operating successfully.

#### Contact address

Government of Pakistan, Appropriate Technology Development Organization, 1-B, 47th Street, F-7/1, Islamabad, Pakistan

### Lakgen biogas generator

*Description.* Modified low-cost biogas generator.

*Technical and economic details.* The traditional gas generator now in use has a floating gas holder

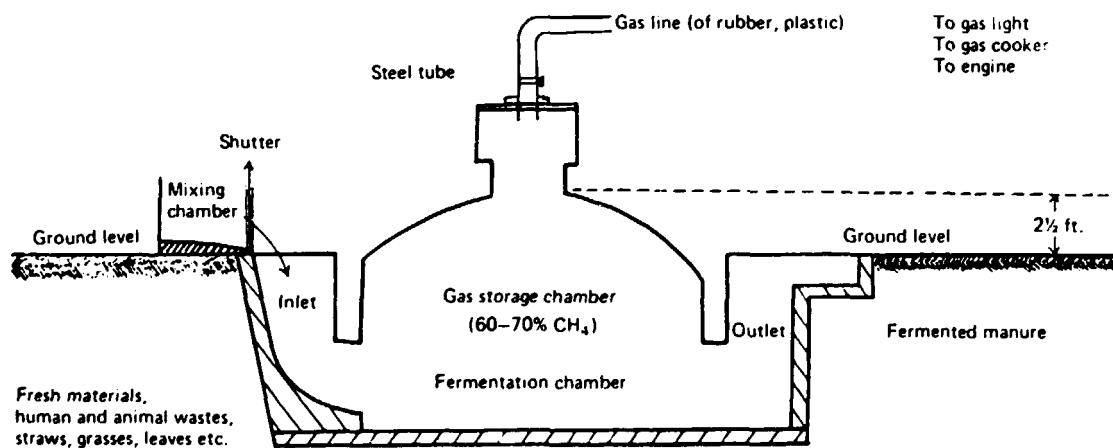

Modified biogas plant

made out of welded sheet metal. Its cost has prevented many interested individuals from erecting gas plants on their premises. IDB has developed a simple, inexpensive generator of brick and cement that can be built at the village level with little expert guidance. The main components are two brick static tanks. In the suburbs of Colombo and even in the rural areas septic tanks are built near some houses to serve the drainage system; in such cases the "Lakgen" principle could be used to solve the problems of fuel requirements. Its advantages are:

(a) It could be used for long periods without much attention;

(b) It is very cheap to construct,

(c) It produces higher pressure than the earlier generator;

(d) Efficiency is improved because sludge is automatically churned from time to time to prevent scum, which can cause problems, from forming;

(e) The gas plant does not use garden space as the tanks are buried in the earth;

(f) There are no metal components. Only a mason's services are needed;

(g) It is made of cement. Replacement or repair is seldom necessary.

The waste material such as cow dung, straw, household refuse etc. is mixed with water and collected in a tank where the generation of biogas begins. The pressure thus created pushes the slurry into the next tank, which is at a higher elevation. When the gas is needed, a valve is opened in the top of the first tank; the flow-back of slurry from the second tank forces it through the outlet.

*Status of commercialization.* Ready for commercialization.

#### Contact address

Industrial Development Board of Ceylon (IDB),  
615 Galle Road, Katubedde, Sri Lanka

#### Biogas generator

*Description.* Generator of methane using agricultural wastes and garbage, with the isolated and screened bacteria as starter.

*Technical and economic details.* For a single biogas digester unit, a minimum of 5 pigs (6 to 8 months old) is necessary to supply the raw material (approximately 5 kg) to produce enough gas as fuel for a family.

A generator made of hollow blocks and cement should be water- and gas-proof. It should be cleaned,

initially, by filling it half full with water to remove acids, carbonates and other chemical impurities that may have detrimental effects on the biogas-producing micro-organisms. After 1 week the water should be pumped out and the digester left to dry for 2 days. Two parts of water for every one part of fresh manure and/or other decomposable material should be put in the digester. For the initial charging, the digester must be 1/3 full.

For a single digester, 3 litres of methane-producing bacteria serve as the starter; 10 different selected bacteria in the prepared starter are required for biogas production. The selected bacteria are first grown separately on agar slants for about 2 weeks. The cultures are kept in an anaerobic chamber and maintained by regular monthly transfers. A nutrients solution is prepared and dispersed at 15 psi for 15 minutes. Two-week-old cultures in test tubes are suspended and mixed in the solution and incubated for a week at a room temperature of 28°-30°C until good bubbling is observed. Biogas can be obtained after 8-12 days from the time the first charging is done. The gas holder rises as the gases accumulate in the digester.

After continuous use for about a year, the digester should be cleaned by removing sediment and other undecomposed matter which can be used as fertilizer and soil conditioner for vegetables and other crops. To resume operation, the same procedure must be followed with a new batch of starter.

A plant based on 60 head of cattle or 45 pigs may produce 90-100 m<sup>3</sup> gas per day which, if used for the generation of electricity, would be equivalent to 80 kW per day or 10 kW for 8 hours (if used to drive, for instance, one or two corn mills) or 16 kW for 5 hours (or sufficient to illuminate a mile of road). The cost of material for constructing a multiple unit is about ₱ 4,000 and for a single unit about ₱ 2,000.

*Status of commercialization.* Several of the biogas generators are successfully used.

#### Contact address

National Institute of Science and Technology,  
P.O. Box 774, Manila, Philippines

#### Charcoal from babassu nut endocarp

*Description.* Utilization of natural energetic resources by transforming of babassu endocarp into high-quality charcoal.

*Technical and economic details.* The process consists essentially of the following operations: endocarp drying, granulometric classification and

carbonization in a continuous vertical furnace, with partial combustion of the endocarp itself by controlled air admission. Products recovered from distillation are tar, acetic acid, phenols, furfural, alcohols etc., and gases. The carbonized product is dried and classified by size. The charcoal can be used either straight or after pelletizing. Coke and/or active carbon can also be produced.

*Status of commercialization.* After pilot-plant production the implementation of the process on an industrial scale is being negotiated.

*Contact address*

Instituto de Pesquisas Tecnológicas do Estado de São Paulo S.A. (IPT), P.O. Box 71411, 01000 São Paulo, Brazil

## XI. Low-cost transport for rural areas

### Load-carrying bicycle

*Description.* Bicycle with metal frame for carrying large loads.

*Technical and economic details.* A metal frame has been designed that can fit an existing bicycle for carrying loads of up to 200 kg. The operator walks alongside the bicycle. It can be used in rugged areas inaccessible to cars and trucks.

The frame is welded and bolted together and then attached to the bicycle. The design has to be adapted to local requirements. The construction is straightforward, although some experience in machining, welding and working with metal will be necessary. The materials needed are a bicycle, an angle bar, tubing and wood strips. Dimensional drawings with text and photos are available.

*Status of commercialization.* The transport bicycle is being widely used.

#### Contact address

Liberation Support Group, P.O. Box 2099,  
Dar es Salaam, United Republic of Tanzania

### Three-wheeled vehicles

*Description.* Simple three-wheeled vehicles for taxi and freight-handling services.

*Technical and economic details.* The three-wheeled vehicles are powered by two-stroke engines and are usually motor scooter derivatives modified by the addition of two chain-driven back wheels. In one instance a heavier commercial vehicle is built around a single front-wheel drive.

The four major producers in this field are:

(a) Bajaj Auto, Poona. Three-wheeled vehicles based on the Italian Vespa motor scooter with a 150-cm<sup>3</sup> engine, now manufactured with 98% Indian components and spares. The three-wheeler is mainly used as a taxi, but the vehicle is also available in the form of a pick-up truck, delivery van and articulated trailer;

(b) Automotive Products of India, Bombay. Three-wheeled vehicles based on the Lambretta motor cycle, now effectively manufactured with 100% Indian components and spares, with 175-cm<sup>3</sup> engine. The vehicle is available in a wide range of

forms, but is primarily supplied as the basic body and cowl for adaptation to the final purpose of the user;

(c) Bajaj Tempo, Poona. Three- and four-wheeled vehicles. The company was historically linked with Bajaj Auto but is now completely separate. The Tempo is a single front-wheel-drive vehicle derived from a Heinkel 395-cm<sup>3</sup> engine based on an original design of a company in the Federal Republic of Germany, now effectively manufactured with 100% Indian components. Unlike the motor scooter derivatives, the Tempo has a fully enclosed driver's cab. Like them it is used for both passenger and goods carriage. The plant is now primarily engaged in manufacture of the four-wheeled Matador van;

(d) Scooters India Ltd., Lucknow. Two-wheeled and three-wheeled vehicles. The company, which is publicly owned, has acquired the Italian Lambretta plant. A separate foundry is under construction, and several semi-independent ancillary industries have been established. A research unit is working on the development of three-wheeled variants.

*Status of commercialization.* The vehicles are commercially produced.

#### Contact address

See the firms mentioned under (a) to (d) above.

### Asian utility vehicle (AUV)

*Description.* Simple vehicle designed for local conditions.

*Technical and economic details.* Five firms manufacture versions of the AUV. Basically, a simple vehicle has been designed around a standard four-cylinder engine. The chassis is simple and easily fabricated. Maximum use is made of flat-body panels that require little forming other than simple bending, usually on a press brake. The development of the AUV has been actively encouraged under the Progressive Car Manufacturing Plan. The lead in the design for the vehicles came from the two major United States manufacturers, Ford and General Motors, both of which have subsidiary assembly companies in the Philippines. A comparatively low investment is needed for facilities and equipment and a high degree of local labour and local material needed in the manufacturing and assembly operations.

In 1975, an estimated 12,500 AUVs were manufactured. The vehicles are all available as simple chassis and cabs (in some cases also as chassis and cowl), as low-side pick-up, as high-side pick-up (with or without canopy), as a van and as a Jeepney. The five main models are listed below:

(a) Fiera, manufactured by Ford Philippines at Rizal. Escort engine, 1,100 or 1,300 cm<sup>3</sup>, imported, payload 1,200-1,700 lb. Philippine content 43%; is also being built in Thailand, and elsewhere;

(b) Harabas, manufactured by General Motors Philippines at Manila. United Kingdom Bedford engine, 1,256 cm<sup>3</sup>, payload 550-750 kg. In addition to the usual range, available as a station-wagon. Design was adapted to local conditions in co-operation with the Francisco Motors Corporation. This basic transport vehicle is also built in 19 other developing countries;

(c) Cimarron, manufactured by Chrysler Philippines at Rizal (P.O. Box 4592, Manila). Developed by Chrysler and Mitsubishi in the Philippines. Neptune engine, 1,400 or 1,600 cm<sup>3</sup>, imported;

(d) Trakbayam, manufactured by DMG Quezon (P.O. Box 1263, Manila). Volkswagen engine, 1,600 cm<sup>3</sup>, imported from Brazil, payload 1,000 kg. DMG also manufactures a 1,500-cm<sup>3</sup> car, the Sakbayan. The main parts supplied by the Volkswagenwerk AG are the engine, the transmission, the axle drive and steering gear while the frame, the driver's cab, the body and all other remaining parts are manufactured in the Philippines. The design of the vehicle was proposed by VW but finally created by the manufacturer in the Philippines. The vehicle is also manufactured in Ghana, Indonesia, Pakistan and Senegal;

(e) Pinyo, manufactured by the Francisco Motors Corporation at Rizal. Mazda engine, 1,200 cm<sup>3</sup>, manufactured in Japan. Developed by Francisco Motors with benefit of experience of General Motors in developing the Harabas.

*Status of commercialization.* The vehicles are commercially produced.

#### Contact address

See firms mentioned under (a) to (e) above.

## Ferrocement boats

*Description.* Method for producing boats and vessels of ferrocement.

*Technical and economic details.* Ferrocement is easily fabricated to any shape, is watertight, fireproof and highly resistant to corrosion and, in comparison with reinforced concrete, is considerably lighter for equal strength. It is best utilized in a thin shell construction, and it can be considered as a replacement for wood, steel and reinforced concrete in a variety of applications.

Ferrocement has gained acceptance as a boat-building material in many parts of the world, and a fairly large amount of technical knowledge has been gained in this field. It is particularly suited to boat building in developing countries for three major reasons:

(a) The construction techniques can be made labour-intensive rather than capital-intensive, if desired;

(b) The technology can be introduced at a level to utilize existing indigenous skills. Except for one or two critical phases, the labour skills required are relatively low;

(c) In most countries, the cost of materials is comparatively low.

Ferrocement working vessels and barges have been successfully constructed with lengths ranging from 20 to 100 ft. In general, the material is somewhat heavier than wood or steel and it has a lower resistance to impact. However, with proper design these deficiencies can be overcome satisfactorily. The major technical advantage of the material is that high-quality ferrocement requires little or no maintenance and, if damaged, can be easily repaired. In addition, it is not affected by marine worms and rot.

*Status of commercialization.* This technology is used in many parts of the world.

#### Contact address

Ferrocement Boatyard, National Fishermen's Cooperative Society, P.O. Box 27, Chittagong, Bangladesh

## **B. Research and development institutes**

# I. Africa and the Middle East

## **Building and Road Research Institute**

A governmental institution, established in 1952, employing 80 professionals, 130 technicians and over 500 others.

*Main areas of activity.* Building materials, building technology, low-cost housing, architecture and planning; traffic and transportation engineering and planning; soil mechanics and foundation engineering; structures.

*Ongoing research and development projects.* Use of timber for school buildings; production of bricks and tiles on a medium scale; kiln for commercial production of lime; use of local materials such as bauxite waste as cementing material in building; production of Portland cement; utilization of mining wastes; pyrolytic conversion of agricultural and timber wastes into char, oil and gas; low-cost roofing materials.

*Contact address:* University, P.O. Box 40, Kumasi, Ghana

*Cable address:* B.R.I.G.A

*Telephone:* 4221/2

*Contact person:* Mr. M. D. Mengu, Liaison Officer

## **Centre national d'études et d'expérimentation du machinisme agricole (CENEEMA)**

A governmental institution, established in 1974, employing 9 advisers, 15 agricultural engineers, 9 technicians and about 50 workers.

*Main areas of activity.* Agricultural mechanization, post-harvest technologies, agro-industry; development, adaptation and testing of agricultural equipment suitable for the United Republic of Cameroon; training of agricultural advisers and farmers in all fields of agricultural mechanization; training of mechanics and tractor drivers; provision of advice and recommendations to the Government, governmental and other institutions as well as private persons in all questions of agricultural mechanization. (See *Corn sheller, Rice thresher.*)

*Ongoing research and development projects.* Construction of agricultural machinery, partly as an adaptation of appropriate technologies developed elsewhere; utilization of local raw materials.

*Contact address:* B.P. 1040, Yaoundé, United Republic of Cameroon

*Telephone:* 22 32 50

*Contact person:* Mr. Ela Eving, Director

## **Family Farms Ltd.**

A non-profit private development organization employing two people.

*Main areas of activity.* Training and consultancy for small farms on agricultural machinery; development of intermediate technology in this field.

*Ongoing research and development projects.* Planter; winged chisel plough; machinery for ground-nuts, sugar beans and sunflower; small-scale shelling and winnowing techniques; solar cooker, windmill.

*Contact address:* P.O. Box 281, Monze, Zambia

*Contact person:* Mr. H. M. Hansen, Technologist

## **Industrial Testing and Research Centre**

A governmental institution, established in 1974

*Main areas of activity.* Analysis, materials testing, industrial information.

*Ongoing research and development projects.* Food and beverage technology, waste treatment, effect of fuel oil on glass quality.

*Contact address:* P.O. Box 845, Damascus, Syrian Arab Republic

*Cable address:* INTEST

*Telephone:* 662438

*Contact person:* Eng. T. Sheikh El-Shabab, Vice-Director

## **International Institute for Tropical Agriculture (IITA)**

An international institution registered according to Nigerian law. It was established in 1967 and employs 600 staff.



*Main areas of activity.* Research and development, evaluation, information, consultancy. (See *Solar-energy-powered crop sprayer.*)

*Ongoing research and development projects.* Alternative to the prevailing shifting cultivation practised in low-lying tropical areas; equipment and process for a minimum tillage with special reference to the reduction of drudgery and to the need for non-animal sources of energy; extension of appropriate technology work to housing, schools, water, power and sanitation is under discussion.

*Contact address:* P.M.B. 5320, Ibadan, Nigeria

*Cable address:* TROPFOUND IKEJA

*Telephone:* 23741

*Contact person:* Dr. Ray Wijewardene, Systems Engineer

#### **Kgatlang Development Board**

Non-profit organization directed by a board of trustees composed of local community leaders, local government officials and representatives of donor agencies. Established in 1968, it employs 2 professionals and 10 others.

*Main areas of activity.* Research and development, training and consultancy in agriculture; building; leather work and mechanics; secondary-school education; production. (See *Mochudi toolbar.*)

*Ongoing research and development projects.* Agricultural technology, horticulture, conservation farming.

*Contact address:* P.O. Box 208, Mochudi, Botswana

*Telephone:* 356 Mochudi

*Contact person:* The Secretary

#### **Leather Research Institute of Nigeria (LERIN)**

A corporate body of the Federal Government of Nigeria, established in 1976, employing 32 senior professionals and technicians.

*Main areas of activity.* Leather manufacture; engineering and process research; application of indigenous materials in leather processing.

*Ongoing research and development projects.* Local salts and vegetable preservatives for treatment of hides and skins; standardization of local vegetable tannages; treatment of tannery effluents; local liming material for leather processing.

*Contact address:* P.M.B. 1052, Zaria, Nigeria

*Cable address:* LEATHER ZARIA

*Telephone:* 0632-2565

*Contact person:* Dr. C. M. Ojinnaka, Head, Research Division

#### **National Council for Scientific Research**

A governmental institution, established in 1967, employing 68 professionals and 118 technicians.

*Main areas of activity.* Food science and technology research; radioisotopes application; textiles testing; cement and concrete testing; building research; animal (local) productivity; water resources research; pest (tick and tsetse fly) research; tree improvement. (See *Production of carbonated beverage from guava fruit, Production of floor tiles from red burning clay, Production of acid-resistant bricks from red burning clays, Production of wall tiles from unrefined china clay.*)

*Ongoing research and development projects.* Production of soya milk, soya flour and baby foods; production of sanitary ware from local ceramic raw materials.

*Contact address:* P.O. Box CH 158, Chelston, Lusaka, Zambia

*Cable address:* NACSIR

*Telephone:* 75321

*Contact person:* Dr. S. M. Silangwa, Secretary-General

#### **Projects Development Institute**

A governmental institution, established in 1970, employing 20 professionals, 281 technicians and 106 administrative staff.

*Main areas of activity.* Process and product research and development, technical assistance, engineering. (See *Garri-processing machinery.*)

*Ongoing research and development projects.* Equipment for parboiling of rice; pulp from rice straw and other wastes; school laboratory equipment; ceramic products etc.

*Contact address:* 3 Independence Layout, P.O. Box 609, Enugu, Nigeria

*Telephone:* 252560

*Contact person:* Mr. J. I. Chinedo, Ag. Secretary

#### **Specialized Institute for Engineering Industries**

A governmental institution, established in 1972, employing 35 persons.

*Main areas of activity.* Product design and development, product technology engineering, quality control, industrial information and documentation, techno-economic study.

*Ongoing research and development projects.* Redesign of air cooler, testing of tractor air filters; testing of agricultural machines; design of fixtures for electrical appliance assembly; quality control systems etc.

*Contact address:* Jamburia Street No. 192,  
P.O. Box 5798, Baghdad, Iraq

*Cable address:* MAHAD

*Telephone:* 69791

*Telex:* 2226 SIEI

*Contact person:* Dr. Abid Ali Sahib Abbas, Director  
General

#### Technology Consultancy Centre

A university department, established in 1971, employing 7 professionals, but drawing upon the services of 350 professionals at the university.

*Main areas of activity.* Research and development in engineering, architecture, industrial art, pharmacy etc.; training, consultancy, small-scale credit.

*Ongoing research and development projects.* Soap production; pyrolytic converter; steel-bolt production; non-ferrous metal casting; sugar production; vegetable oils; lost wax castings for engineering products; handloom weaving; textiles; agricultural machinery and implements; animal feeds; alternative energy sources; craft products; glass and ceramics; glues based on cassava starch and rubber latex.

*Contact address:* University of Science and Technology, Kumasi, Ghana

*Cable address:* KUMASITECH

*Telephone:* Kumasi 5351

*Contact person:* Dr. J. W. Fowell, Director

#### Technology Development and Advisory Unit

A university department, established in 1975, employing four engineers and one technician.

*Main areas of activity.* Research and development activities, especially in mechanical and agricultural engineering; testing and evaluation of new equipment, pilot production. (See *Soil/cement brick-making machine*, *Processing of cashew nuts*.)

*Ongoing research and development projects.* Development of inter-row cultivator; beef marker; cattle cake; cyclone ground-nut shelter; hydraulic ram; solar water heating; alternative sources for electrical energy; low-cost school science equipment; ground-nut decorticating equipment; simplified bore-hole drilling rig.

*Contact address:* P.O. Box 2379, Lusaka, Zambia

*Telephone:* 54755

*Contact person:* Mr. A. M. C. Vissar, Deputy Manager

## II. Asia and Oceania

### **The Ahmedabad Textile Industry's Research Association**

A registered autonomous society, established in 1949, employing 77 scientists and 127 supporting staff.

*Main areas of activity.* Research and development in the areas of textile manufacture (mainly of cotton and cotton/man-made fibre blends) and allied fields. Consultancy and technical services to the textile industry. (See *Use of foam pads at sizing, Improved mechanical stub catcher, Rapidry system for cylinder looms, Auxiliary buffer for picking stick on overpick looms, Roof-cooling system, Modified rope washing machine, Staggering tappets, Swell release motion, Fibre length tester, Short process of bleaching polyester/cotton blends, Low-temperature cure catalyst for wash-and-wear finishing.*)

*Ongoing research and development projects.* Many projects to increase productivity, reduce cost, improve quality, develop new products, all within the framework of intermediate technology.

*Contact address:* Polytechnic P.O., Ahmedabad 380015, India

*Cable address:* ATIRA

*Telephone:* 42671-72-73

*Contact person:* Dr. B. V. Iyer, Assistant Director and Head, Information Centre

### **Applied Scientific Research Corporation of Thailand (ASRCT)**

A state enterprise, established in 1964, employing 175 professionals and 231 technicians.

*Main areas of activity.* Research on utilization of natural resources and services in applied science. (See *Portable essential oil distillation unit, Cupola furnace for foundries.*)

*Ongoing research and development projects.* No details are given.

*Contact address:* 196 Phahonyothin Rd, Bangkok, Thailand

*Cable address:* RESCORP

*Telephone:* 5791121-30

*Contact person:* Wadanyu Nathalang, Governor

### **Appropriate Technology Development Organization (ATDO)**

A governmental organization, attached to the Planning and Development Division of the Government of Pakistan. It was established in 1974.

*Main areas of activity.* Identification of technology "gaps"; research and development or commission of research and development to other suitable organizations; economic evaluation of technologies; promotion and information. (See *Gobar gas plant, Manufacture of matches.*)

*Ongoing research and development projects.* Utilization of indigenous iron ore for steel production in mini steel mills; vegetable dehydration; manufacture of blackboard chalk; small-scale candle-making; simple wool-spinning machine; screw-type cane crushing machine; village-level food processing.

*Contact address:* P.O. Box 1306, 1-B, 47th Street, Islamabad, Pakistan

*Contact person:* M. M. Qurashi, Director General

### **Bethlehem Technical Foundation (Trading)**

A private foundation, established in 1973, employing six professionals and three others.

*Main areas of activity.* Manufacture of equipment for agriculture, soil sampling, land survey and levelling; water management and climatological instruments. (See *Diaphragm pump, Mini thresher.*)

*Ongoing research and development projects.* None at present. Production of cultivators, ploughs, weeders, planters, harrows, sprays etc. is planned.

*Contact address:* P.O. Box 435, Rawalpindi, Pakistan

*Cable address:* BETHFOUND RAWALPINDI

*Telephone:* 44972

*Telex:* 1973

*Contact person:* Manohar L. Gill, Proprietor

### **The Bombay Textile Research Association**

An autonomous society, supported by members and by the Central Government through the Ministry of Industry, employing 167 technicians and 70 administrative staff.

*Main areas of activity:* Research and development in textile technology, with particular reference to cotton and cotton-blends. (See *Stain remover for textiles*.)

*Ongoing research and development projects.* Basic research in the field of textile physics, chemistry and mathematics; applied research in spinning, weaving, bleaching, dyeing and printing; development of suitable mechanical and electronic instruments for use in the textile mills.

*Contact address:* Lal Bahadur Shastri Marg, Ghat Kopar (West), Bombay 400086, India

*Cable address:* MILITRA

*Telephone:* 582651

*Contact person:* Mr. T. V. Ananthan, Director

#### Central Building Research Institute

A governmental institution, established in 1974, employing 180 scientists, 172 auxiliary technicians and 34 technicians.

*Main areas of activity.* Building materials; soil engineering; building physics; building processes, plant and productivity; architecture and physical planning; fire research; rural buildings and environment. (See *Clay flooring and roofing tiles*, *Wood-wool boards*, *Large-size clay products with improved strength*, *Corrugated roofing sheets from coir waste or wood wool*, *Building lime from sugar press-mud*, *Masonry cement from waste lime sludge and Portland cement*, *Cement binder from waste lime sludge and rice husk*.)

*Ongoing research and development projects.* More than 50 projects are distributed over the seven main areas of activity.

*Contact address:* Central Building Research Institute, Roorkee (U.P.), India

*Cable address:* BILDSERCH

*Telephone:* 243, 428, 293

*Contact person:* Professor Dinesh Mohan, Director

#### Central Food Technological Research Institute

A public organization registered under the Societies Act. It was established in 1950 and employs 307 professionals and 208 technicians.

*Main areas of activity.* Research and development activities and training in the field of food science and technology. (See *Production of weaning food*, *Pectin oil and calcium citrate from limes*, *Integrated processing of sesame seed*, *Manufacture of tomato purée*, *Mini rice mill*, *Maize mill*.)

*Ongoing research and development projects.* More than 100 projects in the following areas:

biochemistry and applied nutrition; microbiology, fermentation and sanitation; plantation products and flavour technology; rice milling and pulse technology; flour milling and baking technology; fermentation technology; lipids technology; protein technology; infestation control and pesticides; fruit and vegetable technology; meat, fish and poultry technology; and packaging technology.

*Contact address:* Cheluvamba Mansion, Food Technology P.O., Mysore 570013, India

*Cable address:* FOODSEARCH, MYSORE

*Telephone:* 22660

*Telex:* 0946 241 FTRI IN

*Contact person:* Mr. C. P. Natarajan, Deputy Director

#### Central Leather Research Institute

A public organization (national laboratory under the Council of Scientific and Industrial Research (CSIR) functioning under the Ministry of Education, Government of India), established in 1951, employing 138 scientists and 107 technicians.

*Main areas of activity.* Raw hides and skins and microbiology; slaughterhouse and carcass by-products; tanning agents, tanning and finishing; collagens; polymers; leather auxiliaries; leather trades engineering; extension; economics; leather goods and footwear; tannery effluents and environmental biology; technical training, information. (See *Fertilizer from waste hair*, *Extraction of glue and gelatine*, *Fat liquors for leather processing*, *Mangrove extract*, *Blend extract from myrobalan and babul/konnam*, *Production of pancreatin for leather manufacture*.)

*Ongoing research and development projects.* More than 80 projects in the areas mentioned above.

*Contact address:* Sardar Patel Road, Adyar, Madras 600020, India

*Cable address:* LESERCH

*Telephone:* 412616, 412713, 412868, or 412993

*Telex:* MS 514

*Contact person:* Mr. Y. C. Gokhale, Assistant Director Information Area Leader

#### Central Road Research Institute (CRRRI)

A governmental institution, established in 1952, employing about 200 scientists and technicians.

*Main areas of activity.* Highway engineering research. (See *Lime burnt clay puzzolana mixture (LBCPM)*, *Burnt clay puzzolana (reactive surkhi)*, *Low-grade materials for road construction*, *Utilization of fly-ash*, *Coconut pith as expansion joint filler and building board*.)

*Ongoing research and development projects.*  
Appropriate technology in road construction.

*Contact address:* Central Road Research Institute,  
Delhi Mathura Road, New Delhi 110020, India

*Contact person:* Mr. Y. C. Gokhale, Assistant Director

#### **Ceylon Institute of Scientific and Industrial Research (CISIR)**

A governmental institution, established in 1955,  
employing 85 graduates and 75 non-graduates.

*Main areas of activity.* Process and product  
research on locally available raw materials and  
residues. (See *Machine for decortication of sesame  
seed, Manufacture of ceramic floor tiles, Improved  
method for manioc processing.*)

*Ongoing research and development projects.*  
Solar energy for stills and drying.

*Contact address:* P.O. Box 787, Colombo 7, Sri  
Lanka

*Cable address:* CISIR

*Telephone:* 93 80 7

*Contact person:* E. E. Jeya Raj, Deputy Director

#### **Indian Institute of Packaging**

The Institute was established in 1967; it employs  
35 technicians and professionals and 45 others.

*Main areas of activity.* Research and develop-  
ment; problem-solving; consultancy training and  
education; testing and information and other  
promotional efforts.

*Ongoing research and development projects.*  
Packaging of cement, transport packaging, plastic  
packaging, packaging under tropical conditions.

*Contact address:* Plot E. 2, M.I.D.C., Andheri (East),  
Bombay 400093, India

*Telephone:* 573342 or 57663

*Contact person:* Mr. M. R. Subramaniam, Deputy  
Director

#### **Industrial Development Board of Ceylon**

A state institution, established in 1966.

*Main areas of activity.* Promotion and develop-  
ment of small-scale industries, development of  
appropriate technologies. (See *Diaphragm pump,  
Lakgen biogas generator, Solar wind-ventilated drier,  
Chamber for smoking fish, Coconut cherry cubes.*)

*Ongoing research and development projects.*  
Peanut butter manufacture from ground-nuts; turkey  
red oil (wetting agent) manufacture from castor oil;

soya milk manufacture from soya beans; agar-agar  
manufacture from seaweed; handmade paper manu-  
facture from waste paper etc.; small-scale rubber  
products manufacture etc.; stearic acid from rubber  
seed oil; vegetable dyes from various plants and  
flowers; plaster materials from dolomite and extrac-  
tion of magnesium from dolomite and lime  
puzzolanas; acetic acid from coconut shell; carbon-  
black substitute and manufacture of board from  
waste coir dust; paddy-husk ash as a filler for rubber  
products etc.

*Contact address:* 615 Galle Road, Katubedde, Sri  
Lanka

*Cable address:* KARMANTHA

*Telephone:* 072-450, 452, 394, 323

*Contact person:* L. S. G. Tillekeratne, Director,  
Extension Services

#### **Institute of Textile Technology**

A governmental institution, established in 1922,  
employing 100 professionals and 300 technicians.

*Main areas of activity.* Research, testing,  
consulting, education, training, demonstration plant  
in textile technology.

*Ongoing research and development projects.*  
Treatment of textile fibres; modification of hand-  
loom to vary the design in weaving; batik printing  
on cotton- and wool-blended fabrics; tolerance of  
colour difference for colour matching and quality  
control of dyed fabric; standardization and textile  
quality control.

*Contact address:* Jalan Jendral A. Yani 390, Bandung,  
Indonesia

*Cable address:* INTITEKS

*Telephone:* 71214

*Contact person:* Mr. Soerjosoejarso

#### **The Korea Institute of Science and Technology (KIST)**

A non-profit independent research organization,  
established in 1966, employing 344 researchers and  
84 technicians.

*Main areas of activity.* Product and process  
development; scientific and technological survey and  
analysis in the following fields: mechanical engineer-  
ing, metal and metallurgical engineering, material  
science, electrical and electronic engineering, food  
and biotechnology, industrial economics and systems  
development, and chemistry and chemical engineer-  
ing. (See *Alumina from coal ash, Silicone oils  
production, Production of ethambutol, High-fructose  
corn syrup production, Copper-plated steel wire.*)

*Ongoing research and development projects.* A great number of projects in the areas mentioned above.

*Contact address:* P.O. Box 131, Dongdaemoon, Seoul, Republic of Korea

*Cable address:* KISTROK

*Telephone:* 967-8801

*Telex:* K27380 KISTROK

*Contact person:* Mr. Dal Hwan Lee, Associate Manager, Project Development Department

#### **Lembaga Penelitian Selulosa (Cellulose Research Institute)**

A governmental institution, established in 1968, employing 11 senior professionals, 17 junior professionals and 83 technicians.

*Main areas of activity.* Research and development on utilization of indigenous fibrous resources for cellulose industries (pulp, paper and viscose rayon); engineering and consulting services for cellulose industries; conducting and co-ordinating in-plant training programmes; conducting and co-ordinating technical meetings, seminars etc.; publication of research activities. (See *Use of rubber tree for pulp and paper*, *Dacrydium spp. for pulpwood*, *Use of Agathis lorantifolia for paper pulp*, *Eucalyptus saligna for dissolving pulp and its viscose rayon making*.)

*Ongoing research and development projects.* Utilization of tropical wood species and of agricultural waste for the pulp and paper industry; pollution abatement problems of the cellulose industry.

*Contact address:* Jln. Raya Dayeuhkolot 158, Bandung, Indonesia

*Telephone:* 50623 and 59811, or 81031 and 81032

*Contact person:* Garjito Pringgo Sudirjo, Director

#### **National Institute of Science and Technology**

A governmental institution, established in 1901, employing 272 technicians and 318 unskilled workers.

*Main areas of activity.* Engineering, process research; product standardization; drug chemistry; plant and animal ecology. (See *Canned coconut milk (Gata)*, *Vinegar from coconut water*, *Coconut water as intravenous fluid*, *Biogas generator*.)

*Ongoing research and development projects.* Use of local raw materials, mineral deposits and agricultural wastes; improved methods of manufacture; drugs from local plants.

*Contact address:* P.O. Box 774, Manila, Philippines

*Telephone:* 50-30-41

*Contact person:* Dr. Vedasto R. Jose, Commissioner

#### **Pakistan Council of Scientific and Industrial Research (PCSIR)**

A public organization, established in 1953, employing 550 professionals and technicians and 1,400 others.

*Main areas of activity.* Research and development on the utilization of indigenous raw materials and on solving problems of the industrial sector; industrial extension services; standardization; establishment of new science-based industries. (See *Oil from shark liver*, *Foam concrete*.)

*Ongoing research and development projects.* A large number of projects in the following fields: agrochemical technology; food and fermentation technology; oil, fats and waxes technology; minerals technology; glass and ceramics technology; pharmaceuticals and fine chemicals technology; fuel technology; leather technology; fibre technology; chemical engineering and design; industrial organic and inorganic chemicals; marine foods and applied biology; physical standards; electronics and instrumentation.

*Contact address:* Press Centre, 2nd Floor, Shahrah-e-Kamal Ataturk, Karachi 01090, Pakistan

*Cable address:* CONSEARCH

*Telephone:* 212173

*Contact person:* Mr. M. Aslam, Member (technology)

#### **Philippine Textile Research Institute**

A governmental institution, established in 1967, employing 50 researchers and 37 technicians.

*Main areas of activity.* Textile research, industry development and extension services.

*Ongoing research and development projects.* Sericulture; utilization of pineapple fibres for textiles; crease-resistant finishing of jusi fabrics; fabric handle of ramie blends; easy-care finish for woven cotton; non-wovens from textile processing waste; fabrics for Philippine weather conditions.

*Contact address:* General Santos Ave., Bicutan, Taguig, Metro Manila, Philippines

*Cable address:* PHILTEX

*Telephone:* 83-99-31 or 78-23-93

*Telex:* PHILTEX

*Contact person:* Mrs. Maternidad Palmario, Science Research Supervisor

### Rubber Research Institute of Malaysia

A statutory body (quasi-governmental), established in 1925, employing over 200 senior staff.

*Main areas of activity.* Research and development activities in planting, cultivating and processing of rubber; applied economics; information and documentation; training.

*Ongoing research and development projects.* A large number of projects in the following areas: analytical and applied chemistry; crop protection and microbiology; plant science; rubber technology; quality control; polymer chemistry and physics; soils and crop management; and smallholding rubber cultivation.

*Contact address:* 260 Jalan Ampang, P.O. Box 150, Kuala Lumpur 01-02, Malaysia

*Cable address:* SEARCHING, KUALA LUMPUR

*Telephone:* 467033

*Telex:* RRIM MA 30369

*Contact person:* Haji (Dr.) Ani Bin Arope, Director

### Singapore Institute of Standards and Industrial Research

A governmental institution, established in 1973, employing 100 professionals and technicians and 184 others.

*Main areas of activity.* Standardization and quality control; testing and verification of materials; non-destructive testing and metals technology; instrumentation; metrology; applied research and development; design; consultancy.

*Ongoing research and development projects.* In the electrical/electronic, food and souvenir sectors.

*Contact address:* 179 River Valley Road, Singapore 6, Singapore

*Cable address:* SISIR

*Telephone:* 360933

*Contact person:* Ms. Yeoh Quee Nee, Secretary, SISIR

### Shri Ram Institute for Industrial Research

A public organization run by a foundation, employing 104 technicians and 86 others.

*Main areas of activity.* Process research in the areas of polymers, fibres, organic chemicals, environmental pollution control and analysis and testing. (See *Manufacture of ABS plastics, Improved PVC production, Improved catalyst systems, Protective coating for metal parts (Plastipeel), Unsaturated polyesters, Diallyl phthalate monomer, Prepolymer and moulding compositions, Pentaerythritol, Synthetic pine oil from turpentine, Bisphenol-A, Ethyl ether, Carboxy methyl cellulose, Sulfur resins for textiles, Organdie finish, Sulfuricides for rot-proofing agents for textiles, Manufacture of plaster of Paris, Manufacture of puzzolana clays.*)

*Ongoing research and development projects.* Rubber-reinforced thermoplastics by suspension technique; polyelectrolytes by gamma irradiation; natural rubber-reinforced thermoplastics of commercial importance by irradiation technique; biodegradable polymers; fluoroolefin-based polymers based on tetrafluoroethylene; poly-P-hydroxy benzoic acid; PVC compounds; flocculants and polymeric lubricants.

*Contact address:* 19 University Road, Delhi 110007, India

*Cable address:* SRISANDHAN

*Telephone:* 227954

*Telex:* 3751

*Contact person:* Dr. R. T. Thampy, Director

### The South India Textile Research Association

Sponsored by the Textile Industry and supported by the Government of India, the Association was established in 1956 and employs 106 professionals and technicians.

*Main areas of activity.* Basic as well as applied research in the fields of fibre technology, processing technology up to spinning, weaving problems, machinery development and instrumentation and operational research activities relating to textiles as well as human relations. Research relating to problems of the decentralized sectors like handlooms, powerlooms and hosiery industries is being carried out. (See *High-dome licker-in cover for carding engine, Double carding, Single-yarn mercerization, High-tenacity cotton yarns by mercerization, Use of unconventional fibres, Crease-resistant raw silk fabrics, Two-for-one twisting machine.*)

*Ongoing research and development projects.* Effect of fibre property variables and processing factors on yarn and fabric quality; novel yarns and fabrics from natural and man-made fibres and filaments; increasing wear-life of cellulose, machinery and instruments; blending of natural and man-made fibres; reduction of costs and increase of productivity in mills.

*Contact address:* P.B. No. 3205, Coimbatore Aerodrome Post, Coimbatore 641014, India

*Cable address:* SITRA

*Telephone:* 87-367

*Contact person:* K. Sreenivasan, Director

**South Pacific Appropriate Technology  
Foundation**

A quasi-governmental institution, established in 1977, employing 13 persons.

*Main areas of activity.* Information services on the concept and availability of appropriate technology; importation, testing, evaluation and marketing of A.T. equipment (through Village Equipment Supplies Ltd.); development of appropriate tools and techniques (joint venture with the University of

Technology and the Liklik Bak Information Centre). (See *Hydraulic ram pump, Blacksmith bellows.*)

*Ongoing research and development projects.* Methods of repair and/or recycling of dumped equipment; design of an appropriate hydroelectric generating unit for rural areas.

*Contact address:* P.O. Box 6937, Boroko, Papua New Guinea

*Telephone:* 212499

*Contact person:* Nigel Florida, Associate Director



## III. Europe

### Building Research Establishment

A governmental institution, established in 1921, employing 15 professional and technical staff. In Overseas Division approximately 350 professional and technical staff.

*Main areas of activity.* Research into low-cost material designs and technology for low-cost house construction in developing countries; advice and assistance to developing countries on all aspects of housing and construction.

*Contact address:* Bucknalls Lane, Garston, Watford, United Kingdom

*Cable address:* RESEARCH WATFORD

*Telephone:* 09273-74040

*Telex:* 923220

*Contact person:* Dr. R. F. Stevens, Head of Overseas Division

### Intermediate Technology Development Group Ltd. (ITDG)

A non-profit private organization, established in 1965, employing about 50 persons. Draws on the expertise of over 200 professional advisors operating in 14 panels.

*Main areas of activity.* Research and development; evaluation; promotion; information/publication; consultancy; production. (See *Driven tube-well*,

*Paper pulp moulding system, Hydropower for rural development.*)

*Ongoing research and development projects.* Small-scale glass ware; windmills and river turbines for irrigation pumping; multi-purpose pedal tricycles; mini paper-making plant; mini sawmills; fibre/cement roofing and other building materials; small spinning machinery.

*Contact address:* 9 King Street, London WC2E 8HN, United Kingdom

*Cable address:* IT/DEV, LONDON WC2

*Telephone:* 01-836 9434/39; 836 6379

*Contact person:* Dennis H. Frost, Chief Executive

### Tropical Products Institute (TPI)

A governmental institution, part of the British Ministry of Overseas Development, employing 380 persons.

*Main areas of activity.* Research and development; information; consultancy; training. (See *Maize sheller.*)

*Ongoing research and development projects.* Projects related to problems of post-harvest storage, preservation, processing, marketing and utilization of plant and animal products.

*Contact address:* 56-62 Gray's Inn Road, London WC1X 8LU, United Kingdom

*Contact person:* The Director

## IV. Latin America and the Caribbean

### **Caribbean Industrial Research Institute (CARIRI)**

A governmental institution, established in 1970, employing over 100 persons.

*Main areas of activity.* Research and development; training; information; consultancy; standardization in economics; electronics; engineering; food and chemistry; materials technology.

*Ongoing research and development projects.* Electrical and electronic components; sugar manufacture; use of local agricultural crops; agricultural machinery; weaning food; pollution studies; local pottery, and ceramics; construction material and metal processing.

*Contact address:* Tunapuna Post Office, Trinidad, West Indies

*Cable address:* CARIRI, TRINIDAD

*Telephone:* 662-7161/5

*Contact person:* The Director

### **Center for Economic and Social Studies of the Third World (CEESTEM)**

A governmental institution, established in 1976, employing 64 researchers and 12 technicians in the Center and 12 engineers and 2 technicians in the area.

*Main areas of activity.* Studies in the areas of food, population, culture and education; communication and information, international relations; appropriate technology; research and development on village-level technology.

*Ongoing research and development projects.* Establishment of a rural workshop for the development, testing and manufacture of village-level machinery; special programme on medicinal plants.

*Contact address:* Coronel Porfirio Díaz No. 50, San Jerónimo Lídice, Mexico 20, D.F.

*Telephone:* 595-20-88

*Telex:* 1777579

*Contact person:* Julio A. Corés Hernández, Chemical Engineer

### **Instituto de Investigación Tecnológica Industrial de Normas Técnicas**

A decentralized public institution, established in 1973, employing 90 professionals and 10 technicians.

*Main areas of activity.* Technological research and development; technical information; national standards, metrology, patents.

*Ongoing research and development projects.* Energy: development of solar energy apparatus for cooking of food, dehydration of fruits, desalination of water, water heating and house heating; development of microhydroelectric centrals up to 50 kW; development of windmills for electric energy generation and water pumping. Agriculture: development of simple agricultural tools as well as harvesting, conservation, storage and transport techniques. Housing: adobe housing (two-storey), use of natural building, reinforcements, house sanitation systems, roofing techniques. Food: development of industrialization technologies for Peruvian natural products such as Lupinus, Aguaje, Quinoa, Ungurahui, Majuey etc.

*Contact address:* Apartado postal No. 145, Lima, Peru

*Telephone:* 40 10 40

*Contact person:* Dr. Jorge E. Vega, Director of Technology

### **Instituto de Investigaciones Tecnológicas (IIT)**

A non-profit organization, established in 1958, employing 52 professionals, 28 technicians and 47 others.

*Main areas of activity.* Research and development; quality control; pilot plant production. (See *Dehydrated potatoes, Dehydrated vegetables, Naranjilla concentrate, Vegetable-textured protein, Preservation of fish.*)

*Contact address:* Avenida 30 No. 52-A-77, Bogota, Colombia

*Cable address:* TECNOLOGICO

*Telephone:* 2-35-00-66

*Contact person:* Ms. Teresa S. de Buckle-Jorge Beltran

### **Instituto de Investigaciones Tecnológicas (INTEC/Chile)**

A public organization, established in 1968, employing 77 professionals, 33 technicians, 58 administrative and services staff.

*Main areas of activity.* Research and development; techno-economical studies; transfer of technology; consultancy for industry; industrial information and documentation. (See *Solar grape drier, Windmill for irrigation.*)

*Ongoing research and development projects.* Production of papaina from the Chilean fruit *papaya carica*; processing of the castor oil plant (*higuerilla*); use of thermoplastics from rubbish; utilization of sawdust etc.

*Contact address:* Avda. Santa Maria 06500—Lo Curro, P.O. Box 667, Santiago, Chile

*Cable address:* INTEC/CAS.667

*Telephone:* 285066

*Telex:* 40421-CORFO-CL PARA INTEC

*Contact person:* Sergio Varas, Project Manager

#### Instituto Nacional de Tecnología

A governmental institution, established in 1921, employing 299 professionals and 102 technicians.

*Main areas of activity.* Industrial research, development, engineering and marketing in the areas of renewable natural resources and pollution prevention and control. (See *Ethanol production from manioc roots, Integral use of cellulosic residues by acid hydrolysis process.*)

*Ongoing research and development projects.* Soil, liquid and air pollution prevention and control; industrial design; vegetable oils as diesel engines' fuel and/or lubricants; ethanol stillage; derivative products and their use; continuation of acid hydrolysis of cellulosic residues and production of ethanol.

*Contact address:* Avenida Venezuela No. 82-7° Andar, Rio de Janeiro 20.081, Brazil

*Telephone:* 243.8070

*Contact person:* Fernando Magalhães Machado, Programme Co-ordinator

#### Instituto Nacional de Tecnología Industrial— Centro de Investigaciones Textiles (INTI—CIT)

A governmental institution, established in 1957 (INTI) and 1967 (CIT), employing several professionals and six technicians.

*Main areas of activity.* CIT gives technical assistance to the Argentine textile industry on the following subjects: research on processes, raw materials and their uses, quality control etc.

*Ongoing research and development projects.* Spinning potential of several varieties of national cotton fibres; test methods for textiles; open-end spinning of man-made fibres; manufacture of wool standards for the air-flow apparatus; determination of breaking, resistance, elongation and resilience of wool

fibres; influence of scouring parameters on wool quality; waste waters in the textile industry; relationship between crystallinity and the mechanical and dyeing properties of polyester fibres; quality and behaviour of wool and part-wool yarns made by self-twist spinning.

*Contact address:* Leandro N. Alem 1067-5° piso, 1001 Buenos Aires, Argentina

*Telephone:* 755-7255

*Telex:* INTI BAIRE 012-1859

*Contact person:* Ing. Héctor J. Vázquez, CIT Director

#### Instituto de Pesquisas Tecnológicas

A governmental institution, established in 1899, employing 562 professionals, 482 technicians and 1,080 others.

*Main areas of activity.* Civil engineering; naval engineering; packaging; technical standards and specifications; geology and mining. (See *Light-weight aggregate from urban sewage slime, Substitutions of diesel oil by vegetable oils, Charcoal from babassu nut: endocarp, Ferrocement tanks for liquid storage, Thermophosphate production in mace roasting furnace.*)

*Ongoing research and development projects.* Saw mill for eucalyptus and pine spp.; pre-cast concrete elements for school buildings; organic urban wastes for methane gas production; small-scale production of alcohol from sugar; metal atomization by gas; metal processing by means of explosives; production of ethylene; alternative fuels for motors etc.

*Contact address:* P.O. Box 71411, 01000 São Paulo, Brazil

*Cable address:* TECNINST

*Telephone:* (011) 268.2211

*Telex:* (011) 22831 INPT BR

*Contact person:* Alberto Albuquerque Arantes, Technical Director

#### Technology Policy Group

An Andean subregional organization, established in 1969, employing 4 professionals and 20 technicians.

*Main areas of activity.* Science and technology policy in connection with integration and development on specific projects in the area of importation or innovation of technology at the subregional level. (See *Dissolution of copper from copper sulphides.*)

*Contact address:* P.O. Box 3237, Lima, Peru

*Cable address:* JUNAC LIMA

*Telephone:* 414212

*Telex:* 20104

*Contact person:* Eng. Luis Soto Krebs, Chief

## BIBLIOGRAPHY

*Intermediate Technology Publications Ltd.* (9 King Street, Covent Garden, London WC2E 8HN, United Kingdom) regularly publishes an updated list of publications on intermediate/appropriate technology.

### *Directories of institutes*

*Appropriate Technology in the Commonwealth: A Directory of Institutions.* Gives up-to-date information on 118 institutions in 26 Commonwealth countries. There is a comprehensive index for particular equipment and processes.

64 pp., 1977, price: £1.

May be purchased from: Commonwealth Secretariat Publications, Marlborough House, London SW1Y 5HX, United Kingdom.

*Institutions and Individuals Active in Environmentally-Sound and Appropriate Technologies.* Preliminary world-wide listing of institutes and individuals with activities or an interest in appropriate technology. Information on the institutes and detailed indication of areas of activities. No index for particular equipment and processes.

281 pp., May 1978, no price indicated.

Orders, questions and comments may be addressed to: The International Referral System, United Nations Environment Programme (UNEP), P.O. Box 30552, Nairobi, Kenya.

### *Information sources on technologies*

*Appropriate Technology Source book.* A comprehensive guide to plans and methods for village and intermediate technology with focus on agriculture, food and crop preservation and storage, energy, water supply, housing and health care.

304 pp., second edition, 1976, price: \$US 4.00 (\$US 2.00 for local groups in developing countries).

The book can be ordered from: Appropriate Technology Project, Volunteers in Asia, Box 4543, Stanford, California 94305, USA.

*UNIDO Guides to Information Sources.* This is a series of guides to selected information sources on branches of industry of primary concern to developing countries. Each publication gives information on organizations, directories, statistics, dictionaries and encyclopaedias and various other kinds of publications, bibliographies and

other potential sources of information, all related to a specific industrial sector. The following *Guides* have already been published:

- No. 1/Rev.1 Meat-processing Industry
- No. 2/Rev.1 Cement and Concrete Industry
- No. 3/Rev.1 Leather and Leather Products Industries
- No. 4/Rev.1 Furniture and Joinery Industry
- No. 5/Rev.1 Foundry Industry
- No. 6 Industrial Quality Control
- No. 7/Rev.1 Vegetable Oil Processing Industry
- No. 8 Agricultural Implements and Machinery Industry
- No. 9 Building Boards from Wood and Other Fibrous Materials
- No. 10 Pesticides Industry
- No. 11 Pulp and Paper Industry
- No. 12 Clothing Industry
- No. 13 Animal Feed Industry
- No. 14 Printing and Graphics Industry
- No. 15 Non-alcoholic Beverage Industry
- No. 16 Glass Industry
- No. 17 Ceramics Industry
- No. 18 Paint and Varnish Industry
- No. 19 Canning Industry
- No. 20 Pharmaceutical Industry
- No. 21 Fertilizer Industry
- No. 22 Machine Tool Industry
- No. 23 Dairy Product Manufacturing Industry
- No. 24 Soap and Detergent Industry
- No. 25 Beer and Wine Industry
- No. 26 Iron and Steel Industry
- No. 27 Packaging Industry
- No. 28 Coffee, Cocoa, Tea and Spices Industry
- No. 29 Petrochemical Industry
- No. 30 Non-conventional Sources of Energy
- No. 31 Woodworking Machinery
- No. 32 Electronics Industry
- No. 33 Bioconversion of Agricultural Wastes
- No. 34 Rubber Industry
- No. 35 Utilization of Agricultural Residues for the Production of Panels, Pulp and Paper

The price varies according to the number of pages. These guides may be obtained from bookstores and distributors throughout the world or directly from: Sales Section, United Nations—Geneva (for orders from Africa, Europe and Western Asia); or New York (for orders from Asia and the Pacific and North and South America).

## INDEX OF TECHNOLOGIES

	<i>Page</i>		<i>Page</i>		<i>Page</i>
<b>I. Chemicals and metalworking</b>					
Alumina from coal ash	3	Double carding	10	Large-size clay products with improved strength	20
Bisphenol-A	6	Fibre fineness tester	15	Light-weight aggregate from urban sewage slime	17
Blend extract from myrobalan and babul/konnam	4	Fibre length tester	14	Lime burnt clay puzzolana mixture (LBCPM)	19
Carboxy methyl cellulose	6	High-dome licker-in cover for carding engine	10	Low-grade materials for road construction	23
Copper-plated steel wire	4	High-tenacity cotton yarns by mercerization	10	Manufacture of ceramic floor tiles	21
Diallyl phthalate monomer, prepolymer and moulding compositions	7	Improved mechanical stub catcher	13	Manufacture of plaster of Paris	17
Dissolution of copper from copper sulphides	6	Low-temperature cure catalyst for wash-and-wear finishing	15	Manufacture of puzzolana clays	19
Ethanol production from manioc roots	4	Modified rope washing machine	14	Masonry cement from waste lime sludge and Portland cement	16
Ethyl ether	6	Organic finish	12	Production of acid-resistant bricks from red burning clays	22
Fertilizer from waste hair	4	Rapidry system for cylinder driers	13	Production of floor tiles from red burning clay	22
Improved catalyst systems	5	Roof-cooling system	14	Production of wall tiles from unrefined china clay	21
Improved PVC production	5	Short process of bleaching polyester/cotton blends	15	Resin/natural fibre composites	19
Integral use of cellulosic residues by acid hydrolysis process	3	Single-yarn mercerization	11	Soil/cement brick-making machine	22
Mangrove extract	4	Srifericides for rot-proofing agents for textiles	12	Utilization of fly-ash	23
Manufacture of ABS plastics	6	Sriferet resins for textiles	11	Wood wool boards	18
Pentaerythritol	7	Staggering tappets	12	<b>V. Food storage and processing</b>	
Production of pancreatin for leather manufacture	5	Stain remover for textiles	15	Canned coconut milk (Gata)	27
Protective coating for metal parts (Plasti Peel)	5	Swell release motion	14	Chamber for smoking fish	30
Thermophosphate production in mace roasting furnace	3	Trash analyser	11	Coconut cherry cubes	26
Unsaturated polyesters	7	Two-for-one twisting machine	12	Dehydrated potatoes	26
		Use of foam pads at sizing	13	Dehydrated vegetables	26
		Use of unconventional fibres	11	Ferrocement bins	24
				Ferrocement tanks for liquid storage	25
				Garri-processing machinery	30
				Hand texturizer for food processing	29
				High-fructose corn syrup production	28
				Improved method for manioc processing	28
				Manufacture of tomato purée	27
				Naranjilla concentrate	26
				Pectin, oil and calcium citrate from limes	27
				Preservation of fish	26
				Processing of cashew nuts	29
<b>II. Drugs and pharmaceuticals</b>					
Coconut water as intravenous fluid	8	<b>IV. Cement and building materials</b>			
Extraction of glue and gelatine	8	Building lime from sugar press-mud	19		
Improved strain of ergot	8	Burnt clay puzzolana (reactive surkhi)	20		
Methaqualone and methaqualone hydrochloride	9	Cement binder from waste lime sludge and rice husk	17		
Production of ethambutol	8	Cement from rice husk ash	16		
Silica gel production	9	Clay flooring and roofing tiles	21		
		Coconut pith as expansion joint filler and building board	22		
		Corrugated roofing panels from agricultural residues	18		
		Corrugated roofing sheets from coir waste or wood wool	18		
		Foam concrete	16		
		Funicular shell roof	17		
<b>III. Textiles</b>					
Auxiliary buffer for picking stick on overpick looms	13				
Crease-resistant raw silk fabrics	11				

	<i>Page</i>		<i>Page</i>		<i>Page</i>
Production of a carbonated beverage from guava fruit	27	Manufacture of matches	35	Use of rubber tree for pulp and paper	40
Production of weaning food	28	Wooden lathe	34		
Solar grape drier	29				
Vegetable-textured protein	26	<i>VIII. Oils and fats</i>		<i>X. Energy for rural requirements</i>	
Vinegar from coconut water	30	Fat liquors for leather processing	36	Bicycle-powered water pump	41
		Integrated processing of sesame seed	36	Biogas generator	44
<i>VI. Agricultural machinery and implements</i>		Oil from shark liver	37	Charcoal from babassu nut endocarp	44
Corn sheller	32	Portable essential oil distillation unit	37	Diaphragm pump	41
Machine for decortication of sesame seed	31	Silicone oils production	36	Diaphragm pump	41
Maize mill	32	Substitution of diesel oil by vegetable oils	37	Gobar gas plant	43
Maize sheller	32	Synthetic pine oil from turpentine	36	Hydraulic ram pump	41
Mini rice mill	32			Hydropower for rural development	41
Mini thresher	31	<i>IX. Paper products and small pulp mills</i>		Lakgen biogas generator	43
Mochudi toolbar	31	<i>Dacrydium spp.</i> for pulpwood	39	Low-grade heat recovery turbopack system	42
Rice thresher	32	<i>Eucalyptus saligna</i> for dissolving pulp and its viscose rayon making	39	Solar wind-ventilated drier	43
Solar-energy-powered crop sprayer	32	Paper pulp moulding system	40	Windmill for irrigation	43
		Pulping of rice straw	38		
<i>VII. Light engineering and rural workshops</i>		Pulp-making from rice straw	38	<i>XI. Low-cost transport for rural areas</i>	
Blacksmith bellows	34	Use of <i>Agathis lorantifolia</i> for paper pulp	39	Asian utility vehicle (AUV)	46
Boswell water pump	34			Ferrocement boats	47
Cupola furnace for foundries	35			Load-carrying bicycle	46
Driven tube-well	34			Three-wheeled vehicles	46

**The UNIDO Development and Transfer of Technology Series**

- \*No. 1 National Approaches to the Acquisition of Technology (ID/187), Sales No. E.78.II.B.7. Price: SUS 8.00
- No. 2 UNIDO Abstracts on Technology Transfer (ID/189)
- \*No. 3 The Manufacture of Low-cost Vehicles in Developing Countries (ID/193), Sales No. E.78.II.B.8. Price: SUS 3.00
- No. 4 Manual on Instrumentation and Quality Control in the Textile Industry (ID/200)
- \*No. 5 Technology for Solar Energy Utilization (ID/202), Sales No. E.78.II.B.6. Price: SUS 10.00
- No. 6 Audio-visual Techniques for Industry (ID/203)
- No. 7 Technologies from Developing Countries (I) (ID/208)  
Technologies from Developing Countries (II) (ID/246)
- No. 8 Process Technologies for Phosphat : Fertilizers (ID/209)
- No. 9 Process Technologies for Nitrogen Fertilizers (ID/211)
- \*No. 10 Brickmaking Plant: Industry Profile (ID/212), Sales No. E.78.II.B.9. Price: SUS 4.00
- No. 11 Technological Profiles on the Iron and Steel Industry (ID/218)
- No. 12 Guidelines for Evaluation of Transfer of Technology Agreements (ID/233)

In Europe, North America and Japan, all the numbers listed above are free except those marked with an asterisk, which are distributed in those areas in a separate sales edition at the price shown. Outside Europe, North America and Japan, all the numbers are free without exception.

Requests for free copies, quoting title and ID number, should be addressed to the Editor, *UNIDO Newsletter*, P.O. Box 300, A-1400, Vienna, Austria.

Copies of the sales editions should be ordered by title and sales number from an authorized distributor of United Nations publications or from one of the following offices:

*For Europe*  
Sales Section  
United Nations Office  
CH-1211 Geneva 10  
Switzerland

*For North America and Japan*  
Sales Section  
United Nations  
New York, New York 10017  
United States of America







with  
09983

2



**CORRIGENDUM**

ID/246  
June 1981  
New York

Development and Transfer of Technology Series  
No. 7

**TECHNOLOGIES FROM DEVELOPING COUNTRIES (II)**

*Corrigendum*

*Page 17, second column*

*Line 28 should read*

handled manually. The shells are just one inch thick

*Page 22*

Delete the second column

000017

