



**TOGETHER**  
*for a sustainable future*

## OCCASION

This publication has been made available to the public on the occasion of the 50<sup>th</sup> anniversary of the United Nations Industrial Development Organisation.



**TOGETHER**  
*for a sustainable future*

## DISCLAIMER

This document has been produced without formal United Nations editing. The designations employed and the presentation of the material in this document do not imply the expression of any opinion whatsoever on the part of the Secretariat of the United Nations Industrial Development Organization (UNIDO) concerning the legal status of any country, territory, city or area or of its authorities, or concerning the delimitation of its frontiers or boundaries, or its economic system or degree of development. Designations such as “developed”, “industrialized” and “developing” are intended for statistical convenience and do not necessarily express a judgment about the stage reached by a particular country or area in the development process. Mention of firm names or commercial products does not constitute an endorsement by UNIDO.

## FAIR USE POLICY

Any part of this publication may be quoted and referenced for educational and research purposes without additional permission from UNIDO. However, those who make use of quoting and referencing this publication are requested to follow the Fair Use Policy of giving due credit to UNIDO.

## CONTACT

Please contact [publications@unido.org](mailto:publications@unido.org) for further information concerning UNIDO publications.

For more information about UNIDO, please visit us at [www.unido.org](http://www.unido.org)

22912

Ozone-friendly industrial development

# **Impact and lessons learned— solvents (including process agents) and aerosols**

UNIDO in the Montreal Protocol—  
technology transfer to developing countries



UNITED NATIONS INDUSTRIAL DEVELOPMENT ORGANIZATION

# **Ozone-friendly Industrial development**

## **UNIDO in the Montreal Protocol - technology transfer to developing countries**

Impact and lessons learned—  
Solvents (including process agents)  
and aerosols



**UNITED NATIONS INDUSTRIAL DEVELOPMENT ORGANIZATION**  
**Vienna, 2003**

Copyright © 2003 by the United Nations Industrial Development Organization.  
First published 2003.

United Nations Industrial Development Organization, Programme Development and  
Technical Cooperation Division, Multilateral Environmental Agreements Branch  
Vienna International Centre  
P.O. Box 300, A-1400 Vienna, Austria.  
Tel.: +43 1 260 26-0; fax: +43 1 260 26-6804; internet: <http://www.unido.org>

Designations employed and the presentation of material in this publication do not imply the expression of any opinion whatsoever on the part of the Secretariat of the United Nations Industrial Development Organization (UNIDO) concerning the legal status of any country, territory, city or area, or of its authorities, or concerning the delimitation of its frontiers or boundaries. The opinions, figures and estimates set forth are the responsibility of the authors and should not necessarily be considered as reflecting the views or carrying the endorsement of UNIDO. The mention of firm names or commercial products does not imply endorsement by UNIDO.

All tons are metric and all dollars are U.S. dollars.

This document has not been formally edited.

## About this series

This booklet is one of a series of six designed for specialists interested in the effectiveness and efficiency of UNIDO's sectoral programmes for phasing out the use of ozone depleting substances (ODSs) by industry and agriculture. Covering refrigeration and alternative technologies for domestic appliances, refrigerant management plans, plastics foams, solvents (including process agents and aerosols) and fumigants, they focus on the complex interventions required to replace technologies, equipment and operating procedures in the main ODS-consuming sectors. Each sector calls for a different set of technical, economic and (in some cases) social solutions. Case study presentations show that the common benefit of adopting of ozone-friendly technologies is the opportunity to improve productivity, product design and quality and to move into new markets. The series documents not only the implementation of cost-effective projects, but also the many indirect benefits of UNIDO's work—such as technology transfer, employment generation, support for SMEs and institutional capacity building.

The series places UNIDO's efforts as an implementing agency for the Multilateral Fund (MLF) of the Montreal Protocol in the context of UNIDO's mission to support developing countries and countries in transition in their pursuit of sustainable industrial development. UNIDO interprets such development as the accomplishment of three things: (i) protecting the environment—with industry complying with environmental norms, efficiently utilizing non-renewable resources and conserving renewable resources; (ii) encouraging a competitive economy—with industry producing for export as well as domestic markets; and (iii) creating productive employment—with industry promoting long-term employment and increased prosperity.

## Abbreviations

CFC	chlorofluorocarbon
CTC	carbon tetrachloride
DPRK	Democratic People's Republic of Korea (DPR Korea)
DI	De-ionized
EDC	ethylene dichloride
HAP	hydrocarbon aerosol propellant
HFC	hydrofluorocarbon
ISO	International Standards Organization
LPG	liquefied petroleum gas
MLF	Multilateral Fund of the Montreal Protocol
MP	Montreal Protocol
o.d.	outer diameter
ODS	ozone-depleting substance
ODP	ozone-depleting potential
PFC	perfluorocarbon
POP	persistent organic pollutant
SME	small or medium scale enterprise
TCA	trichlorethane
TCE	trichlorethylene
TLV-TWA	Threshold Limit Value-Time Weighted Average
UV	ultraviolet
VOC	volatile organic compound

# Contents

## Foreword

### SOLVENTS, incl. PROCESS AGENTS

Ozone depleting solvents  
UNIDO and the solvent sector  
Substitute solvent technologies  
Electronics  
Precision cleaning  
General metal cleaning  
Scope and approach of solvent conversion projects  
Technology transfer leadership  
Safety and product quality  
Small and medium-size enterprises  
Barriers to phase-out

#### Case studies:

Converting metal cleaning from ODS solvents to trichlorethylene degreasing:  
Bearing Factory (DPR Korea)  
Converting CFC-113 and CFC-11 cleaning processes to aqueous cleaning:  
Huangshi Dongbei Refrigeration Co. (China)  
Phasing out carbon tetrachloride from 2,6 dichlorophenol production: Amoli  
Organics Ltd. (India)

### AEROSOLS

Conversion technologies  
UNIDO-managed technology transfer  
Safety and product quality  
Technology transfer to SMEs

### Tables and Figures

- Table 1 Use of solvents  
Table 2 Average ODS solvent consumption in selected Article 5 countries  
Table 3 MLF approvals in the solvent cleaning sub-sector  
Table 4 MLF approvals in the process agent sub-sector  
Table 5 UNIDO aerosol projects funded by the MLF
- Fig. 1 Catalytic chlorination with chlorine and perchlorethene yields active pharmaceutical ingredient Diclophenac  
Fig. 2 Old process used carbon tetrachloride to recover 2.6 dichlorophenol intermediate  
Fig. 3 In new process with new catalyst, cyclohexane substitutes carbon tetrachloride in finishing, cleaning and distillation stage  
Fig. 4 Share of ozone depletion potential phased out by sector

## FOREWORD

The year 2002 has seen a milestone in UNIDO's contribution to preserving the stratospheric umbrella that protects life on earth from the sun's radiation - the ozone layer. Eleven years ago in October, the Organization became an implementing agency to the Montreal Protocol. It accepted, thereby, the challenge of helping cut back the use of ozone depleting substances (ODSs) that threaten the future of all life forms on our planet.



In that short interval since UNIDO became an implementing agency for the Montreal Protocol's Multilateral Fund, the Organization successfully eliminated an annual consumption of more than 24,500 tons of industrial chemicals that would otherwise have torn an even larger hole in the protective ozone shield. The allocation of 25 per cent of the Multilateral Fund's resources to UNIDO, increasing, as of 2003, thanks to the strong portfolio of projects, is unequivocal recognition of the Organization's track record in tackling the industrial challenges of today's world.

Working closely with the Fund's Secretariat and the United Nations Environment Programme, UNIDO applies its expertise in industry to transferring technology and know-how so that ODS consumption and its ozone depleting potential are reduced. Their impact has far exceeded the limited staff resources available within the Organization. A major success factor has been the establishment of an organizational branch dedicated to Montreal Protocol activities, which I created when transforming UNIDO in 1998.

Since then, UNIDO's role in combating ozone depletion has gone from strength to strength. But it has also taken on a new dimension, namely to help developing countries to benefit from globalization through increased trade. By enabling their industries to comply with environmental export requirements, UNIDO has opened up new markets for their industrial goods thus encouraging the growth of selected manufacturing sectors. The cooperation between UNIDO, the Multilateral Fund, other international agencies, donors and ODS technology recipients in pursuing the goals of the Montreal Protocol, demonstrates that collective multilateral efforts can indeed have a substantial impact on threats - environmental, economic and others - that face mankind.

Meanwhile the task of eliminating ODSs from industry is far from finished. To meet the challenges ahead, UNIDO is expanding its support for Montreal Protocol activities. In addition to individual projects to transfer ozone-friendly technologies, UNIDO will help developing countries plan their own phase-out programmes for ODSs. This summary booklet and its accompanying technical reports are an insight into one of the key value-added services that UNIDO offers its clients. They are also an industrial blueprint for protecting the ozone layer in the twenty-first century.

Carlos Magariños  
Director-General

## **SOLVENTS, including PROCESS AGENTS**

Solvents are liquids with the ability to dissolve, suspend or extract other materials, without chemically changing those materials or themselves. They have been used in many industrial areas over many years, e.g. to:

- remove grease from metals and printed circuit boards,
- produce intermediates for pharmaceuticals and agrochemicals, chlorinated polymers and polyurethane foam materials, and to
- remove paints and coatings or in dry cleaning.

Solvents are freely soluble, and can easily be reconcentrated and recycled. Some, like CFC-113 (trichlorotrifluoroethane), methyl chloroform (1,1,1-trichloroethane or TCA) and carbon tetrachloride (tetrachloromethane or CTC) are considered to be the substances chiefly responsible for stratospheric ozone depletion. They contribute to the man-made greenhouse effect and, because they are also possible health hazards for people working with them (as well as being harmful for the environment), their substitution with alternative products has become imperative.

Between 1995 and 2002, UNIDO, other UN agencies and their counterparts eliminated around 4500 ODP-tons of ozone-depleting solvents. Their approach is an integrated one, taking into consideration ecology, safety, economics and social affairs and balancing their impact. In particular, when designing and developing process alternatives, UNIDO always strives to ensure that economy and ecology go hand in hand. UNIDO insists on integrating environmental protection and plant safety into processes, and on maximizing resource productivity. This means that less harm is caused to the environment by products and production methods. Production processes are organized with a higher degree of safety; fewer valuable natural resources are utilized.

In-process environmental protection means developing production methods in such a way that emissions are, where possible, totally avoided – thus leading to a minimum disposal of waste gases, waste water and solid waste. In many cases, it is possible to recover solvents after they have been used and feed them back into the production process. The solvent is then used several times, increasing cost-effectiveness through reduced purchases.

In-process plant safety calls for designing processes so that they run as safely as possible, protecting employees and neighbouring communities from possible dangers associated with the hazardous substances used. Beginning with the selection of a suitable method of cleaning or synthesis, UNIDO builds a series of measures into the production process. It designs processes that keep quantities of hazardous substances in the plants to a minimum. But because even the best planning cannot eliminate errors completely, it also organizes processes and plants in such a way that one error alone cannot put people or the environment at risk. And since even the best technology cannot function without practitioners at plants, UNIDO ensures that the staff using the new equipment are fully qualified to operate it safely. They are trained in safe handling of the plant and materials, and are provided with easy-to-understand instructions both for normal operations and irregularities.



### *Ozone depleting solvents*

CFC-113, TCA and CTC are used as solvents in various applications (see table 1). Their primary uses are:

- cleaning of electronics assemblies
- cleaning of precision/optical components
- cleaning of metal parts, and
- dry cleaning and spot removal.

CFC-113 and TCA found favour because they combine low toxicity with good solvency power.

CTC while being a good, low-cost solvent, is classified as toxic/carcinogenic. As a process agent it functions as an inert reaction medium in chlorination, bromination and Friedel-Crafts-acylation reactions that produce chlorinated rubbers and paraffins, intermediates for pharmaceuticals and production of pesticides. CTC can be avoided or substituted in these applications by other non-ODS process solvents such as ethylene dichloride (EDC), toluene, perchloroethene, tetrahydrofurane and others.

**Table 1 Use of solvents**

<b>Cleaning agents</b>	<b>Process agents</b>	<b>Formulation agents</b>
metal parts	chlorine	aerosol pesticides
heat exchangers and condensers	chlorinated rubber and paraffins	correction liquids
ball bearings	pharmaceutical intermediates	spray coatings
Electronics assemblies and printed circuit boards	agrochemicals and intermediates	lubricants
plastics		fabric protectants
textiles		

Source: UNIDO Solvents Unit

The Montreal Protocol Secretariat reports that about 16,000 ODP tons of CTC, CFC-113, and trichlorethane remain to be phased out in future years in developing countries' solvent sectors, especially in China (4106 ODP tons and India 3,000 ODP tons). Starting from 1995, UNIDO itself has phased out 1,638 ODP tons within the framework of 50 MLF-approved solvent cleaning projects, accounting for 6 per cent of the total UNIDO ODS phase-out. Eleven projects were approved in the process agent sector (591 ODP tons) where UNIDO pioneered the phase-out of CTC in the pharmaceutical sector.

As estimated from Country Programmes (CP) and from assumptions for other countries, unconstrained consumption of solvents in 1993 was approximately 24,000 ODP tons, i.e. around 10 per cent of all ODP industrial consumption. Table 2 shows average consumption figures in ODS and ODP tons and by percent based on Country Programme of seven of the top ten solvent-consuming Article 5 countries.

**Table 2 Average ODS solvent consumption in selected Article 5 countries (1993)**

Total consumption in country		Solvents sector Consumption					
ODS (tons)	ODP (tons)	ODS (tons)	ODP (tons)	CFC-113 (ODS tons)	CFC-113 (ODP tons)	TCA (ODS tons)	TCA ODP (tons)
		Share of total (%)	Share of total (%)	Share of total (%)	Share of total (%)	Share of total (%)	Share of total (%)
16,831	16,127	5,771	2,287	1,273	6,246	3,776	378
		41.5%	19.4%	9.6%	9.3%	25%	3.9%

Source: Country programme data from China, India, Mexico, Thailand, Brazil, Indonesia and Malaysia.

These seven countries, each with a significant small-scale and informal sector, have a combined ODS and ODP solvents consumption averaging 41.5 per cent and 19.4 per cent respectively of their total ODS and ODP tons consumed. However roughly estimated, the figures underline the importance of the sector, given that those seven countries account for over 50 per cent of the total estimated ODP consumption in Article 5 countries.

An important aspect of each country's Country Programme is therefore the national strategy for dealing with the solvent consumption in the small-scale and informal sector, which in developing countries is characterized by the presence of a large number of enterprises. It is estimated that in India, Indonesia, Malaysia, Pakistan and Philippines two thirds of the ODS solvents consumed by such enterprises are in annual quantities of less than 5 tons (many of them less than 1 ton ODS per annum). As such, they fall outside the acceptance range (i.e. their cost-effectiveness thresholds set up by the Montreal Protocol Fund are too high) for project eligibility, given the large capital incremental cost of ODS phase-out projects that could conceivably be implemented to eliminate solvents consumption. (In the remaining one third of the sector, the enterprises are typically large and sophisticated enough to be able to implement projects technically. Between them they account for the majority of the approved projects fall.)

#### *UNIDO and the solvent sector*

UNIDO has been active in the solvent sector right from the beginning of its work with the Multilateral Fund. The organization has prepared solvent and process agent projects in the following countries: Brazil, China, Egypt, India, Indonesia, Iran, Jordan, Kenya, DPR Korea, Pakistan, Peru, Turkey and Yugoslavia. Projects to be prepared in other countries: Argentina, Mexico, Nigeria and Romania.

Tables 3 and 4 show that the share of UNIDO solvent and process agents investment projects approved by the MLF up to March 2002 is higher than the average of the Fund's portfolio. In solvent cleaning, ODP phased out by UNIDO was 2.4 per cent of its portfolio compared to the MLF's average of 2 per cent. UNIDO's leading role is also evident in its use of 27.7 per cent of the total amount approved for the sub-sector; UNIDO has more

solvent projects approved than other implementing agencies. Furthermore, UNIDO's solvent projects are also 30 per cent more cost-effective than the sectoral average, i.e. UNIDO has been spending only \$10.13 to phase out one kg of ODS, while the average of the total portfolio of the Fund is \$14.14 /kg.

**Table 3 MLF approvals in the solvent cleaning sub-sector**

Item	UNIDO		Multilateral Fund	
	Total	Share of total (%)	Total	Share of total (%)
ODP phase-out (solvent) ODP tons	1,638.2	4.5	4,243.6	2.4
Funds approved (solvent) \$ millions	16.6	5.8	60	4.5
Cost effectiveness (solvent), \$/kg	10.15		14.14	
Share of funds for UNIDO solvent projects compared to the total funds approved for solvent sector for all Implementing Agencies				27.7
Share of UNIDO solvent projects compared to the total number of projects approved for sector for all Implementing Agencies				41.7

Source: MLF 39<sup>th</sup> Inventory

In the process agent sector, UNIDO was the first agency to develop sub-sectoral profiles to phase CTC out of ibuprofen, bromhexane and diclophenac in the pharmaceutical industry in India and Pakistan. Some 56% of the MLF funding allocated for the sub-sector came to the UNIDO programme, which consequently developed more process agent projects than other implementing agencies.

**Table 4 MLF approvals in the process agent sub-sector**

Item	UNIDO		Multilateral Fund	
	Total	Share of total (%)	Total	Share of total (%)
ODP phase-out (process agent), ODP tons	591	1.6	1,214	0.7
Funds approved (process agent), \$ millions	2.9	1.0	5.2	0.4
Cost effectiveness (process agent), \$/kg	4.88		4.28	
Funds for UNIDO solvent process agent projects as compared to the total funds approved for process agent sector for all Implementing Agencies				55.8
Number of UNIDO solvent process agent projects as compared to the total number of projects approved for this sector for all Implementing Agencies				73.3

Source: MLF 39<sup>th</sup> Inventory

### *Substitute solvent technologies*

There is no single substitute for all uses of CFC- 113, methyl chloroform and carbon tetrachloride. Every solvent area has at least one or more available alternatives. CFC- 113, for example, has been widely used as a solvent precisely because it fits many different applications. Thus, any substitute for CFC-113, methyl chloroform and carbon tetrachloride should exhibit most, if not all of their useful characteristics—particularly in cleaning effectiveness. UNIDO's criteria in selecting a suitable substitute are that it should have:

- low ODP, global warming potential, and volatile organic content;
- low toxicity or carcinogenic character ;
- feasible recovery and recycling cost effectiveness;
- alternative processes that are safe and do not generate other environmental hazards;
- emissions that can be minimized by the use of closed equipment.

In applications where toxic chemicals are the only current substitutes, their use is accepted only subject to strict work place controls.

### *Electronics*

Solvent losses in the electronics industry are often large. Most occur during cleaning, the rest during recovery and other handling operations. In conventionally maintained plants, total recovered solvents consumed may be as low as 20 per cent. Thus, up to 90 per cent of all solvent loss in the electronics industry can be eliminated through conservation, recovery and recycling at minimal net cost. Pending development of longer-term solutions, such processes will be vital while equipment and procedures are modified. CFC-113's main advantage to the electronics industry as a non-corrosive solvent is already less compelling now, thanks to the increasing use of more solvent-resistant assembly coatings. This has led to a greater use of methyl chloroform, but it also allows the wider use of other, harsher substitutes. Electronic assemblies can be specifically designed with aqueous cleaning in mind. Military specifications are currently being changed to allow use of non-rosin fluxes and aqueous cleaning. Replacement chemicals and technologies are already commercially available. Nevertheless, the most environmentally-sound alternative is the elimination of cleaning altogether. A number of fluxes and flux application technologies exist which make that alternative viable.

Many alternative solvents could replace CFC-113 and methyl chloroform in electronics cleaning, either singly or in combination using different processes. Other chlorinated solvents such as trichlorethylene, perchlorethylene and methylene chloride have been used as effective cleaners for many years and have been extensively tested. However, in some countries, the first two are regulated as volatile organic compounds (VOCs) because they contribute to tropospheric ozone formation.

Hydrocarbon/surfactant solvents are mixtures of organic compounds and agents that reduce the surface tension of water thus improving the efficiency of water cleaning. Organic chemicals used in conjunction with surfactants include terpenes, alcohols, aldehydes and esters. They are non-corrosive, have low viscosity and foaming values, remove both polar and non-polar contaminants, and are useful for cleaning closely-spaced electronic assemblies at low temperatures. They do require specially designed explosion-proof equipment because of their low flash points and potential room temperature flammability; and, because they are classified as VOCs, their mists and vapours must be contained. These

blends can be used to clean all types of soldered assemblies, and most electronic assembly components are compatible with most of them. Terpene wastes may be hazardous and require proper disposal to prevent further environmental problems. A new hydrocarbon/surfactant blend, ethyl lactate, is an excellent non-toxic cleaner that mixes with water, but may deplete oxygen in discharged wastewater. Waste chemicals from these solvents have not yet been extensively tested.

Other organic solvents, such as ketones and alcohols, are effective in removing both solder fluxes and many polar contaminants. Being flammable and classified as VOCs, they can be used only in small quantities in well-ventilated areas. Isopropanol looks promising as a substitute and is an acceptable cleaner for activated rosin and other military-approved fluxes. Special equipment required for flammable alcohol-based solvents is now commercially available including cold solvent cleaners, hot solvent cleaners, vapour-phase batch cleaners, in-line cleaners and immersion cleaners. Most use ultrasonic agitation and/or sprays to achieve more thorough cleaning.

### *Alternative technologies*

Aqueous cleaning requires no distillation equipment and often no water pretreatment. This can result in cost savings (although these may be offset if wastewater treatment and disposal are needed). Water is excellent for removing ionic contaminants and water-soluble fluxes; in combination with saponifiers, it can remove non-polar substances such as rosin flux residues, oils and activators. Water may also be combined with alcohol, neutralizers and detergents to maximize cleaning effectiveness. If during cleaning it becomes too contaminated to remove fluxes effectively, it must be treated by deionization, reverse osmosis or carbon adsorption. Aqueous cleaning equipment includes mechanized brush cleaning machines, dishwasher-type batch machines, high-throughput batch machines, tank-immersion batch machines, and in-line conveyORIZED machines, each method being relevant to specific electronics applications.

Combination cleaning is used where no single solvent can remove all flux residues, e.g. when some contaminants are not water-soluble and some are not solvent-soluble. Substitute solvents can be used in conjunction with aqueous cleaning. Cost comparisons between aqueous and solvent cleaning favour aqueous methods by a small margin, particularly for large manufacturers—even taking into account the need for wastewater monitoring and disposal.

UNIDO-favoured no-clean options include the use of low solid fluxes in printed circuit board manufacture. They can eliminate the need for cleaning altogether in numerous applications, particularly in consumer electronics, where a relatively low level of cleanliness is required.

### *Precision cleaning*

Much progress has been made in developing alternatives to CFC-113 and methyl chloroform in precision cleaning, including substitute solvents and new or improved technologies. Conservation methods can be implemented immediately in some applications (for example, clean-room assembly) to reduce current CFC-113 and methyl chloroform use and emissions in the short term. Major considerations in finding alternatives for precision

cleaning solvents are ease of drying and material compatibility—due to the large range of materials and parts and the delicacy of the instruments in this sector.

HCFs have similar properties to CFC-113 and methyl chloroform, including compatibility with most metals and plastics. Regulated as transitional substances, their use is likely to be controlled.

Alcohols and ketones may be used in precision component cleaning, subject to material compatibility and use of explosion-proof or gas-blanketed equipment for low flash-point alcohols. Together with ultrasonic agitation, boiling isopropanol combined with acetone is a substitute in many applications—although not in large-scale clean-room operations, nor for polymers.

Perfluorocarbons (PFCs)—compounds in which all hydrocarbon hydrogen atoms have been replaced by fluorine—demonstrate great chemical stability, low toxicity, non-flammability and low ODPs. They are particularly suitable solvents for medical applications where pure oxygen is used at high pressure, and for cleaning high accuracy gyroscopes. The equipment needs to be designed according to the application, however. On the other hand, PFCs are costly and have very high global warming potentials; they are thus unlikely to be acceptable as long-term substitutes. PFCs can be used as vapour blankets over alcohol cleaners to render them less flammable, thereby providing an effective cleaning mix. Aliphatic hydrocarbons (such as mineral spirits, n-paraffin and kerosene) can be used as substitutes in processes similar to aqueous cleaning—with the advantage of not requiring water. They have been extensively tested. Recovery processes such as carbon adsorption are essential because many aliphatics are classified as VOCs. Trichlorethylene, perchlorethylene and methylene chloride may be used in compliance with national regulations.

#### *Alternative technologies*

Water is the most likely long-term precision cleaning substitute for CFC-113 and methyl chloroform. It works better than CFC-113 when removing ionic contaminants, but is less effective in removing some organic contaminants. It also dries slowly if special drying techniques are not used. Aqueous cleaning involves the use of spray, ultrasonic, hot-air and vacuum oven drying processes. Product design can affect cleanability and a rapid spot-free dewatering system may be necessary.

Semi-aqueous cleaning uses hydrocarbon/surfactant blends as emulsions in water solutions, or in concentrated form followed by water rinsing. The method is effective and is compatible with most materials; however, safe worker exposure levels have not been established for some blends, and energy consumption may be high unless rinse water is recycled.

Plasma cleaning, widely used for cleaning gyroscopes, depends on electrically charged gases (such as oxygen, argon, helium and silicon tetrafluoride) to remove contaminants. Radio frequency discharges produce the plasma, and these raise the energy levels of the charged particles in the plasma sufficiently to break the chemical bonds in organic contaminants. Volatile compounds are formed as a result, which are swept out of the chamber by a gas. The process is non-toxic and has low operating costs. However, capital cost can be high and contaminant layers are not always cleaned at an even rate. Plasma cleaning is a viable option only for special circumstances, since its use must always be preceded by solvent cleaning to achieve an ultra-clean, smooth surface.

Filtered, contaminant-free pressurized gas or air is increasingly used as a CFC-113/methyl chloroform substitute for cleaning cross hairs in surveying instruments, high definition cathode ray tubes and electron guns to remove non-metallic dust and particles. Supercritical fluids are gases held above the critical temperature and pressure at which they would normally condense. Such gases are powerful solvents. They work rapidly to remove medium-molecular weight and low polar substances. They involve low operating costs but, again, incur substantial capital costs.

Ultraviolet (UV) light combined with ozone can be used to remove organic films from a wide variety of surfaces—glass, quartz, sapphire, ceramics, metals, silicon and polyamide cement. Cleaning results from oxidation, which is induced by a photosensitive chemical reaction. UV/ozone cleaning is simple, inexpensive and rapid. Concerns about worker and material exposure to UV light, and low work place ozone limits (0.1 ppm), mean that specially designed equipment is needed, which entails further testing and development.

### ***General metal cleaning***

The wide range of substrates being cleaned and the variety of processes used in metal cleaning and finishing mean that process-specific alternatives must be found for reducing CFC-113, methyl chloroform carbon tetrachloride use.

As in other sectors, significant amounts of solvent can be recovered by improved operating practices and by using conservation processes specific to metal degreasing. There are a few cleaning applications for which immediate substitution is limited to other chlorinated solvents, aliphatic hydrocarbons or aromatic hydrocarbons.

Where metal substrates (such as mild steel parts) could be corroded by other solvent substitutes or where heavy contamination needs removing, trichlorethylene, perchlorethylene and methylene chloride are alternatives to methyl chloroform.

Many non-corrosive, biodegradable solvents have been identified and tested to replace chlorinated and CFC solvents. They include: petroleum distillate, ethyl ester, potassium hydroxide primed alcohol, 4-isopropenyl-1-methylcyclohexene, alkyl acetate ester and dipropylene glycol/monomethyl ether. Other potential metal degreasing compounds include hydrocarbon/ surfactant blends, dibasic acid esters and n-methyl pyrrolidone.

For cold immersion and manual cleaning, commercial solvent blends are already available, including mixtures of aliphatic and aromatic hydrocarbons (naphtha, toluene, xylene) and oxygenated solvents (ketones, esters and alcohols). Cold immersion in these blends removes heavy grease and other industrial contaminants. New blends are being developed to minimize flammability (their chief disadvantage) and toxicity.

Alkaline cleaners are the most widely applicable substitutes for metal degreasing and could replace 75-90 per cent of current methyl chloroform and CFC-113 solvent use. Their active ingredients include anionic and non-ionic surfactants, chelating and sequestering agents, and corrosion inhibitors. Hundreds of alkaline cleaners are available, and more are being developed for special applications. Acidic cleaners may be used to remove rust and scale, and to clean aluminium, which reacts with high alkalinity solutions, particularly those containing sodium hydroxide.

### *Alternative technologies*

Aqueous cleaning uses immersion with mechanical agitation (impeller-type mixers or pumps) or spray processes. Ultrasonic agitation is applicable in small-scale systems. Each requires different equipment that may have optional features such as solution heaters, dryers, part handling automation equipment, solution filtration, recycling and water treatment equipment. Proper waste disposal is important in aqueous cleaning, because some byproducts are not biodegradable; this adds to cost.

Emulsion cleaners (hydrocarbon/surfactants) are used in semi-aqueous cleaning and have many different formulations. They are used with ultrasonic agitation and fluid circulation to clean metal parts. Their advantages are low vapour pressures, low evaporation loss, low flammability and low flashpoints, as well as being potentially less expensive than CFC-113. But they have associated recycling and disposal problems, low contaminant-saturation capacity and require special equipment. Aqueous immersion and solvent emulsions in semi-aqueous processes can be used in all metal-cleaning operations. Tubing, complex shapes, and sensitive materials all require specially designed equipment, which has been tailored for that specific process. Additional research and system design work is needed when considering complex applications for aqueous/alkaline and emulsion cleaning technologies.

Thermal vacuum de-oiling can be used to clean parts after cutting, machining and stamping, and in preparation for coating and heat treatment. Oil is removed from parts by vapourization in a heated vacuum chamber to give a super-clean finish. The operation is simple, but contaminant specific.

No-clean options for metal degreasing include water-soluble, emulsifiable machining and metal forming lubricants (some non-chlorinated). They are much easier to remove with aqueous cleaners and not hazardous to workers. Dry lubricants and thin polymer sheeting which can be peeled from a metal surface after a metal forming operation are being developed. The technology is still in its infancy, however.

### ***Scope and approach of solvent conversion projects***

As a lead agency in the solvent sector, UNIDO has developed the most solvent projects and accumulated great experience in replacing old cleaning degreasers with modern technology. It has also secured the most modern degreasing technology for transfer to Article 5 countries, where cleaning is an essential part of production. In general UNIDO finds serious deficiencies in the existing cleaning operations in Article 5 countries, for example inadequate worker protection and little understanding of the need to protect the environment. It makes a special point of addressing these needs in its projects.

UNIDO is also deeply involved in technology transfer through its projects in the solvent sector. It introduces good practices and codes of conduct both in manufacturing operations and in training people. As a result, there have been tremendous strides in the control of processes and in the safe storage, handling and use of cleaning solvents. Nevertheless, some difficulties have been encountered in implementing solvent projects. The cost-effectiveness for the individual ODS has been reduced significantly—for example for CTC it is now less than \$10/kg whereas in principle it should be close to \$20/kg. Incremental operating savings (IOS) coming from almost all solvent projects and extended to 4 years considerably reduce incremental capital costs needed to implement a project. UNIDO works hard to develop



good co-operation with the beneficiaries and to encourage them to share in the costs of their projects. In many cases, small projects cannot be formulated individually. In such cases, UNIDO explains the problems associated with replacement of CTC or TCA and makes necessary recommendations.

## *Technology transfer leadership*

UNIDO started to formulate its first investment projects in the solvent sector in 1994 for the electronics industry in India. There, and later in Egypt, it was the first to use hydrocarbons in the cleaning of electronics assemblies. At that time cleaning machinery developed by some companies in Europe used hydrocarbons of the Class AIII (flash point  $> 55^{\circ}\text{C} < 100^{\circ}\text{C}$ ) to replace CFC-113 for cleaning of printed circuit boards. Later, while preparing projects in metal cleaning to replace TCA, UNIDO used vacuum in closed trichlorethylene cleaning machines to reduce the drying time in the cleaning cycle in order to increase the cleaning throughput.

In summary, UNIDO projects in the solvent sector provide:

- Access to the latest non-ODS technologies, alternatives and expertise on the market;
- Assistance in research and development work to identify alternative technology for a particular application case;
- Technology upgrading to maintain international competitiveness;
- Workforce training in non-ODS related design, research and development and equipment operating practices;
- Introduction of safety protection components, which recipient companies often lack;
- Industrial level compliance with ODS-related international and national regulations and standards;
- Assistance to small-scale industries;
- Links between industry and government promoting technology transfer.

A major constraint is the priority needed for the use of locally available products. For example, in DPR Korea, top priority is assigned to the principle of self-reliance. Therefore, UNIDO deliberately concentrated on using replacement cleaning solvents and agents (trichlorethylene and alkaline cleaner components) that are, or can be, locally produced.

UNIDO learned by experience that adequate attention must be paid in the solvents sector to the problems of securing reliable sources and stability of electric power. Modern equipment tends to have components (such as computer chips) that can be sensitive to power outages and voltage fluctuations.

Provisions for waste disposal may be rudimentary, in which case projects need to include measures and recommendations that solve such problems and do not simply transfer disposal from one environmental compartment to another.

## *Safety and product quality*

Protection of the environment and worker health are critical aspects of the implementation of any programme using MLF funding. The solution of one problem should not result in the creation of other problems as could be the case with methylene chloride, perchlorethylene and trichlorethylene which are significantly more toxic than either CFC-113 or 1,1,1-trichloroethane (methyl chloroform), for which they may be proposed as replacements. This is a concern because, after the Montreal Protocol agreement was ratified, the cost of TCA went up and there was a tendency in Article 5 countries to use trichlorethylene instead of the ozone depleting solvent TCA in the TCA degreasers—without taking into account the occupational and environment protection issues.

For these reasons, UNIDO has been evaluating state-of-the-art technologies in the solvents projects, especially where protection of health and the environment are needed, with due consideration to the limits imposed by cost-effectiveness parameters. This is part of the sustainable development approach. UNIDO was the first to specify worker exposure limits for equipment using solvents supplied to developing countries. It opposed proposals to modify and/or retrofit existing degreasers as being both non-cost-effective, unsafe and not environmentally friendly.

Current use of ODS solvents in developing countries is often carried out in rudimentary conditions (such as open tanks) with minimal consideration for health, safety and the environment. UNIDO therefore insists on replacement technology that is appropriate to working practices in developed countries, even though this does not necessarily provide an upgrade in the technical performance of the solvents. In situations where chlorinated solvents are the preferred technical replacement for the ozone-depleting solvents traditionally used for surface cleaning of sensitive parts, closed cleaning equipment with solvent recycle is provided, together with measures for protecting worker health and safety. Introducing appropriate safety measures frequently remedies significant deficiencies in the operating practices of companies.

Where ODSs are used as process agents, a significant level of industrial progress will already have been attained in that country. Nevertheless the above concern for worker health and safety, as well as concern for environmental protection will still be driving forces in project planning and implementation. In these applications carbon tetrachloride is substituted where possible by modifying existing technologies and using appropriate alternative solvents. Exceptionally, a new technology may need to be developed or licensed.

In the area of environmental protection of the atmospheric compartment, the Volatile Organic Compounds (VOC) directive of the European Union now restricts stack emissions of chlorinated solvents to 20 mg/cu m and in the case of trichlorethylene this will further be reduced to 2 mg/cu m. This has force-fed the development of improved closed solvent cleaning equipment so that modern installations are competitive with retrofits and at the same time provide improved worker health protection and reduced loads on the environment. All such new developments have been reflected in UNIDO solvent projects.

Provisions for waste disposal may also be rudimentary in Article 5 countries. UNIDO projects therefore include measures and recommendations that solve such problems and do not simply transfer disposal from one environmental compartment to another. Pending completion of the regulatory revision process described above, UNIDO intends to apply the precautionary principle by using a TLV-TWA value of 5 ppm for trichlorethylene in the work place and will insist that suppliers of new equipment and retrofitters meet this limit.

### ***Small and medium size enterprises***

As noted earlier, small and medium size enterprises when taken collectively, consume the greatest volume of ozone depleting solvents. Because in many countries they are usually distributed over a wide range of regions where user identification is an immense task, only minimum attention has been paid to them. Nevertheless, it is increasingly evident that SMEs in Article 5 countries require more assistance if they are to make the transition to non-ODS technologies and at the same time avoid severe economic and social dislocations.

UNIDO has extensive experience of working together with SMEs and two thirds of all its projects in the solvent sector fall into this category. It is an area which is avoided by other MLF implementing agencies, but nevertheless represents many thousands of small and medium users of ODS, which are collectively responsible for the major part of ODS emissions of this sector. Thus an essential feature of the formulation of Sector Phase-out Programmes is the identification of the role of SMEs in terms of both numbers of companies and their use patterns. In this respect, UNIDO is the leading agency in terms of experience and results to date. Of its 50 solvent projects in the cleaning sub-sector and 11 projects in the process agent sub-sector, 38 address SMEs.

Because of their smaller-scale, SME ODS phase-out investment projects will never be as cost effective as those for larger companies. Nevertheless, UNIDO and its clients have ascertained that the present high cost-effectiveness thresholds established by the MLF for project proposals in the solvents sector have led to cases where the majority of SMEs and ODS users in the informal sector (which have a large combined scope for solvents elimination—particularly CFC-113 and TCA) fall outside the acceptance range of project approval. UNIDO has accumulated experience in negotiating with beneficiaries of MP grants belonging to SMEs on their contribution to project costs to enable approved projects be implemented. Such an agreement is normally reflected in a Working Arrangement, which is signed by UNIDO and the beneficiary before the start of project implementation.

### ***Barriers to phase-out***

Barriers to ODS phase-out in the solvent sector are:

- Environment not being a priority concern.
- Environmental issues in general, and ozone layer protection specifically, are not considered priorities, given limited time.
- Due to the established rules and regulations in the solvent cleaning sub-sector, incremental operating savings usually associated with the technology transfer are calculated on a four-year basis. As a result, a project's cost is considerably (sometimes 50 per cent) lower than the originally planned cost.
- SMEs often cannot make additional monetary contributions, creating serious problems for project implementation.
- Due to their small size and limited human and financial resources, companies in Article 5 countries have great difficulties in acquiring information on suitable conversion processes. It is a requirement that the project document provides complete information on the new technology selected and its cost.
- As a rule, companies are unable to select a suitable solution out of the dozens available. Normally a selection of alternative technology is made on the basis of technical advice given by UNIDO experts.
- SMEs in particular are poorly equipped to identify suppliers of new technology, equipment and chemicals.
- Cost effectiveness thresholds set up in 1995 have to be reconsidered to allow the preparation of solvent projects for SMEs.

## ***Converting metal cleaning from ODS solvents to trichlorethylene degreasing: Bearing Factory (DPR Korea)***

Sector: solvents

Company: Bearings Factory, DPR Korea

Project no.: MP/DRK/98/079

Project title: Conversion of Metal Cleaning Processes from ODS Solvent to (TCE) Vapour Degreasing at Pyongyang September 18 Bearings Factory, DPR Korea.

### ***Background***

The Pyongyang September 18 Bearings Factory (BRG), is a state-owned company employing some 3,000 people. The factory was built in 1986 and equipped mostly from the former Soviet Union sources, with some inputs from the former German Democratic Republic and the Federal Republic of Germany. The factory makes bearings of all sizes, ranging from 4 mm i.d. to 600 mm o.d.

### ***Alternative technology selection***

Open tanks had been used for CTC solvent cleaning. After a joint review of the situation with the factory, some cleaning operations were replaced by closed equipment, using TCE as solvent; others were replaced by modern aqueous alkaline cleaning machines.

The project phased out 110 tons of carbon tetrachloride (CTC) in metal-cleaning operations by replacing the CTC cold dip method with trichlorethane (TCE) vapour degreasing technology. It replaced five CTC automatic cleaning machines designed for CTC solvent with aqueous cleaning machines. The \$1.1 million budget covered procurement of six TCE ultrasonic solvent degreasers and three aqueous machines, a solvent recovery unit and ancillary equipment. It deployed commercially available technology in a factory located in a city with a significant number of metals and machinery enterprises, thus creating a focal/learning point for other factories. Elimination of ODS in this sector is a priority for the DPRK's action plan under the 1996-2010 Country Programme, which features the principle of maximum self-reliance.

### ***Services provided***

UNIDO paid special attention to assuring worker safety and health by selecting machines of modern design. Measures were also taken to protect the environment, for example by providing equipment for solvent recovery and recycling.

### ***Impact***

The project:

- Eliminated CTC emissions to the atmosphere
- Eliminated landfill disposal of CTC wastes
- Upgraded technical skills of the workforce
- Upgraded quality of output
- Introduced best practices including process and quality improvement; safety consciousness raised significantly.

Energy consumption increased significantly due to conversion from manual- to machine-cleaning, but chemicals consumption was much reduced by solvent recycling and use of closed equipment. Final cost-effectiveness was \$8.93/ODP kg.

## ***Converting CFC-113 and CFC-11 cleaning processes to aqueous cleaning: Huangshi Dongbei Refrigeration Co. (China)***

Sector: solvents

Company: Huangshi Dongbei Refrigeration Co., P.R.China

Project no.: MP/CPR/97/074

Project title: Conversion of ODS Cleaning Processes from CFC-113 and CFC-11 to Aqueous Cleaning

### ***Background***

Huangshi Refrigeration Equipment Co. manufactures room air conditioners, cold drink refrigerators and compressors. It has a capacity of 1 million compressors annually. During production, all metal parts were cleaned in CFC-113 cleaning machines. All parts for assembly supplied by other factories in China were also cleaned. In addition, parts were cleaned after surface treatment operations (phosphating) prior to assembly. Precision cleaning is necessary due to the high requirements for cleanliness of the compressor parts, control of water content, and control of dust content.

### ***Alternative technology selection***

The recipient company opted to replace CFC-113 with aqueous cleaning featuring spraying and ultrasonics in four major stages, i.e. washing with surfactant, tap-water rinsing, DI-water rinsing and drying in order to phase out CFCs.

The \$236,242 project phased out 32 tons of CFC-113 and 12 tons of CFC-11. The cleaning processes with CFC-113 had been primarily used as a degreasing agent in vapour cleaning of compressor parts for production of refrigerator compressors. CFC-11 was used as a flushing agent for repair of faulty assembled crankcases.

### ***Services provided***

UNIDO provided two new aqueous cleaning machines from FinnSonic, Finland. In addition, the recipient company itself co-financed at a cost of around \$250,000 the purchase of two aqueous cleaning machines, a centralized DI-water plant and dehydration. It also bought a drying air system with a molecular sieve to dry the compressors before final assembly. Assistance was provided on selection of appropriate detergents applicable for the cleaning of compressor parts in water. FinnSonic also provided technical advice and staff training in machine operations.

### ***Impact***

The project demonstrated the technical and economic feasibility of new alternative cleaning processes applicable to compressor production by:

- Eliminating CFC-113 and CFC-11 emissions into the atmosphere
- Eliminating landfill disposal of CFC-113 wastes
- Upgrading technical skills of the workforce
- Upgrading quality of output
- Introducing best cleaning practices
- Significantly increasing safety consciousness in the company.

Project cost-effectiveness was \$6.28 per ODP kg. Due to cleaning in water, it also enabled significant operating savings —\$193,858 calculated on a 4-year basis.



*Phasing out carbon tetrachloride from 2,6 dichlorophenol production: Amoli Organics Ltd. (India)*

Sector: process agents

Company: Amoli Organics Ltd

Project no.: MP/IND/01/225

Project title: Conversion of Carbon Tetrachloride as Process Agent to Cyclohexane at Amoli Organics Ltd., Mumbai (India)

**Background**

Amoli Organics Ltd., an Amoli Group member, is a 30 year-old pharmaceutical enterprise with its own R & D centre. The company manufactures and markets generic active ingredients and various formulations to Good Manufacturing Practice (GMP) standards and has an established position in Indian and developing country markets. Amoli's production site for Diclofenac and other pharmaceutical products such as carbamazepine, celecoxib, clotrimazole, oxarbazepine and triclosan is in Vapi, Gujarat.

The pharmaceuticals are produced in three shifts daily with a work force of 300 employees. Annual turnover is \$7.8 million. In 1992, the company started production of Diclofenac, an active pharmaceutical ingredient for combating specific inflammations, with an installed capacity of 300 ton/year. It currently produces 210 tons/year. The UNIDO project was designed to phase out the 35 tons of CTC used as process solvent in the manufacture of 2,6-dichlorophenol, a Diclofenac precursor.

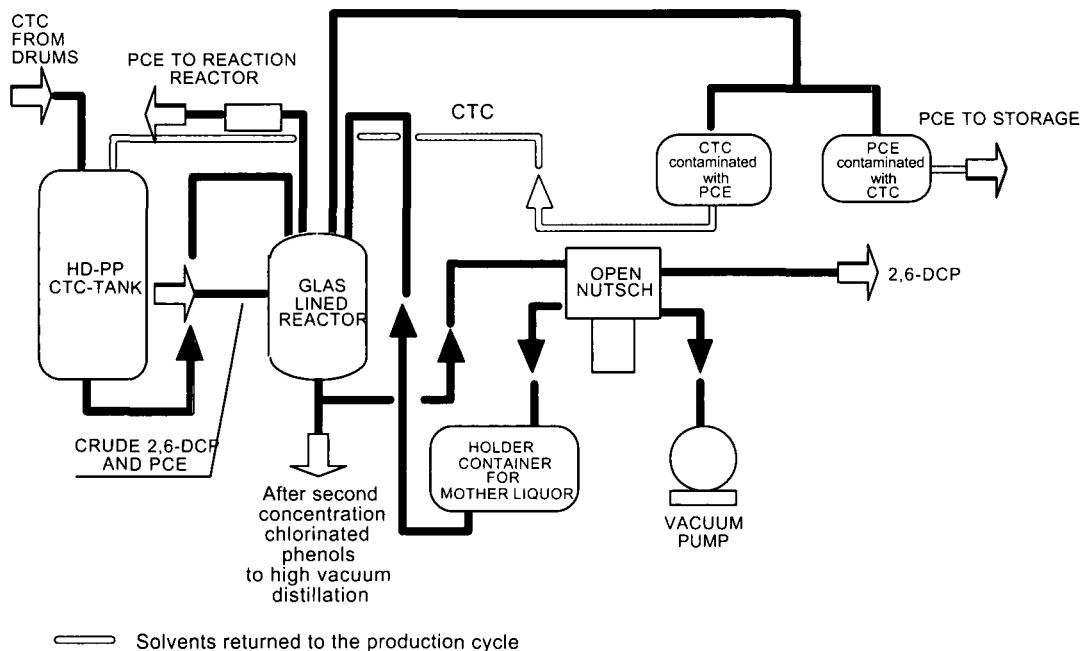

Fig. 1: Catalytic chlorination with chlorine and perchlorethene yields active pharmaceutical ingredient Diclophenac

The batch process comprises a 6-step sequence starting with the chlorination of phenol to the intermediate 2,6-dichlorophenol, for which CTC was used as process solvent. Due to poor process control measures and severe deficiencies in the chemical process and plant design, large quantities of solvent, hydrogen chloride and hazardous waste (consisting of uncountable phenol derivatives—dioxins, perchlorinated phenols etc.) were released into the environment thus polluting soil, water and air.

### Alternative technology selection

In the redesigned process isopropyl amine is used as a highly regio-specific catalyst in the phenol chlorination, so that the undesired precursors of persistent organic pollutants (POPs) could be eliminated. Instead of carbon tetrachloride the non-toxic and non-ozone depleting cyclohexane has been deployed. Because of flammability of the new solvent, all operations are carried out in a closed system under nitrogen blanketing and reduced temperatures. The installation of a rectification unit will contribute considerably to the improvement of the solvents recycling rate and the purity of the separated substances needed for further use.

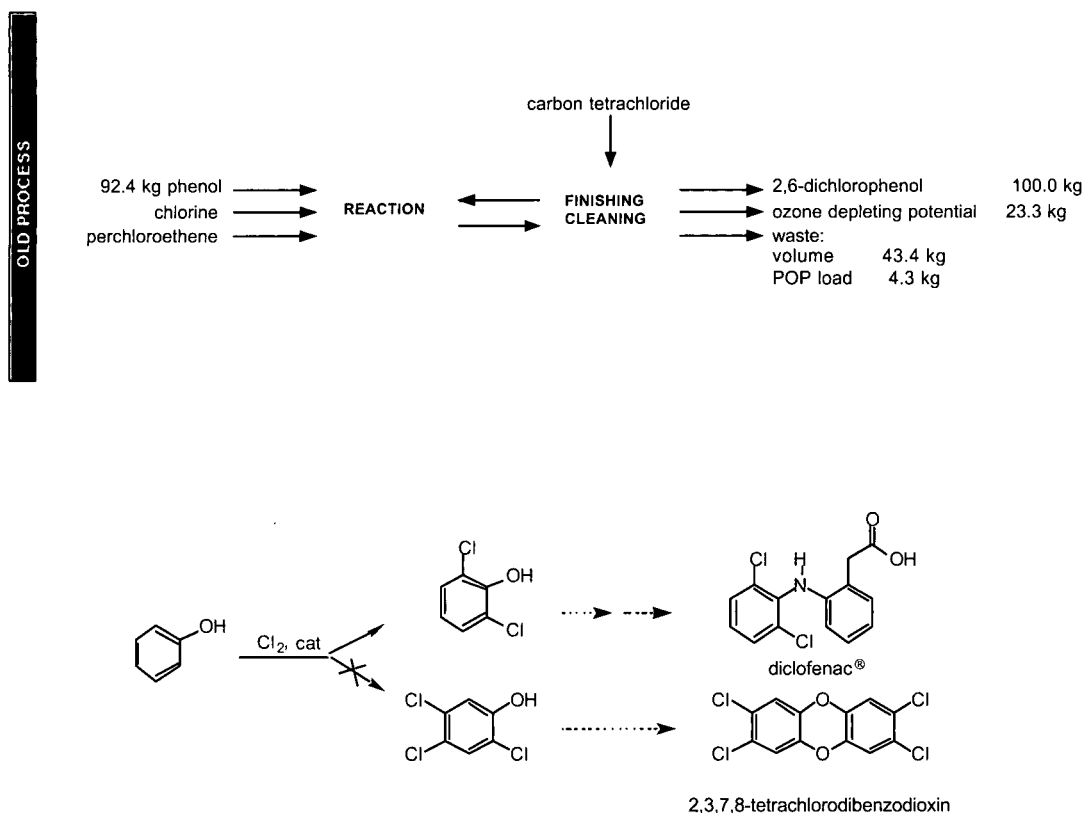

Fig. 2: Old process used carbon tetrachloride to manufacture and purify 2,6-dichlorophenol intermediate

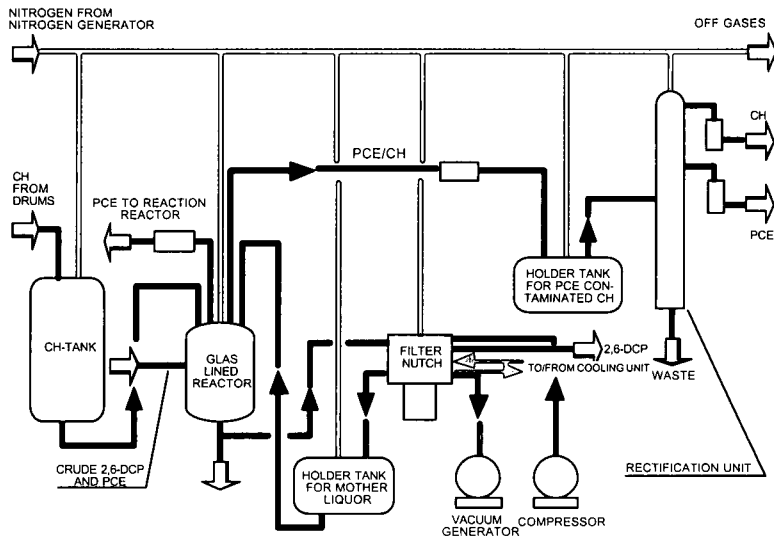
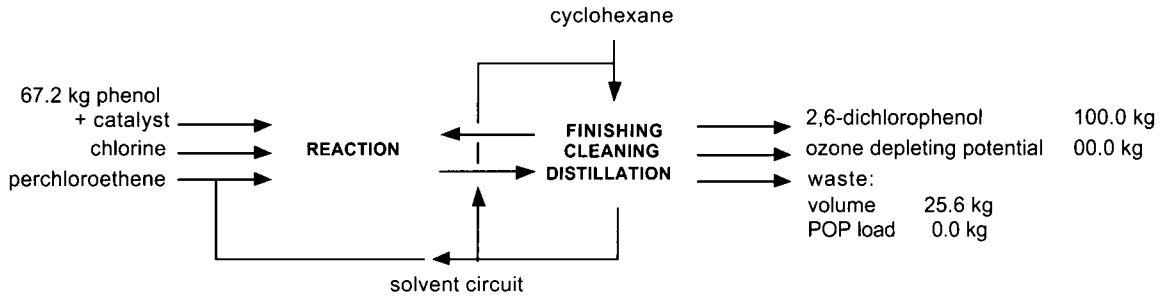

Fig. 3: In a new process with new catalyst, cyclohexane substitutes carbon tetrachloride in the purification step

### *Services provided*

The counterpart provided infrastructure and work related to it (buildings, foundations, installations etc.). The replacement of carbon tetrachloride by non-toxic cyclohexane contributes considerably to improved occupational safety. Plant safety is ensured through organizational measures (procedures, training of staff members), technical measures (flame arresters, nitrogen blanketing etc.), and a fire fighting system.

The dimensions, design and materials were thoroughly optimized and selected to avoid energy losses.

### *Impact*

The project:

- Totally eliminated the ozone depleting substances;
- Increased the selectivity of the chlorination reaction, thus improving product quality (purity and safety) and avoiding formation of persistent and toxic dioxins;
- Improved occupational and process safety measures;
- Increased yields from 62 up to 88 per cent thus reducing raw materials and energy consumption and operating costs by 28 per cent;
- Improved solvent recycling rate;
- Enhanced competitiveness on local and foreign markets thanks to improved product quality, lower manufacturing cost and environmentally sound production;
- Reduced waste by approximately 41 per cent.

Eco-efficient phase-out of CTC increased added value by reducing environmental impact. The added value in terms of sustainability accrued from improving product value (purity of drugs and intermediates), reducing the consumption of resources (raw materials, energy), and by minimizing environmental impact (emissions, solid waste).

In terms of environmental damage, significant improvements included total elimination of emissions of ozone depleting substances and substantial reductions in volatile organic compounds. Thanks to a new type of catalyst and optimal solvents, previously unavoidable dioxin-type POPs are no longer generated.

Project cost effectiveness was \$10.01 /ODP kg phased out (spin offs not considered).

---

*Explanatory notes*

VOCs	Volatile organic compounds are organic compounds with boiling points of $\leq 150^{\circ}\text{C}$ (1,013 mbar) or vapour pressure of $\geq 1$ mbar ( $20^{\circ}\text{C}$ ). VOCs are measured at the source or calculated from material balances.
Emissions	Solid, liquid and gaseous substances released into the environment as a result of chemical, industrial and even biological processes. Emissions include noise heat and radiation.
POPs	Persistent organic pollutants are organic compounds of natural or anthropogenic origin that resist photolytic, chemical and biological degradation. They are characterized by low water solubility and high lipid solubility, resulting in bioaccumulation in fatty tissues of living organisms. POPs are transported in the environment in low concentrations by movement of fresh and marine waters and they are semi-volatile, enabling them to move long distances in the atmosphere, resulting in widespread distribution across the earth, including regions where they have never been used.
Eco-efficiency	Economic concept designed to increase added value by reducing environmental impact. The intrinsic elements of this concept are: <ul style="list-style-type: none"><li>▪ Reducing material intensity</li><li>▪ Reducing energy intensity</li><li>▪ Reducing waste and emissions</li><li>▪ Enhancing recycling</li><li>▪ Maximizing the use of renewable resources</li><li>▪ Extending product durability</li><li>▪ Increasing service intensity</li></ul>

---

## AEROSOLS

Aerosols are collections of tiny solid particles or liquid droplets that are finely dispersed in a gas. To disperse active ingredients of a product effectively, the aerosol propellant must evaporate quickly. Compressed gas is of limited use, because the pressure in the container falls as the container empties. Since liquefied gases do not suffer from this problem, CFCs quickly became a preferred propellant in the aerosol industry that expanded rapidly after World War II. Thanks to their good dispersion characteristics, good solubility, non-flammability, stability as well as being non-toxic and non-explosive, CFCs were widely used in the production of aerosol lacquers, deodorants, shaving foams, perfumes, insecticides, window and oven cleaners, pharmaceuticals and veterinary products, paints, glues, lubricating oils and many other products. CFC-11, CFC-12 and CFC-114 (for dispersing products containing alcohol) were used most widely.

In the mid-1970s aerosol products accounted for 432,000 metric tons of CFCs, i.e. about 60 per cent of their consumption world-wide. By the end of the decade, however, countries were beginning to ban or restrict their use. After the introduction of the Montreal Protocol in 1987, their use in aerosol products began to decline rapidly. As a result, overall consumption of CFC dropped from 180,000 tons in 1989 to an estimated 15,000 tons in 1995.

### *Conversion technologies*

The three most practical and commercially available CFC replacement substances adopted for the aerosol sector are hydrocarbons, dimethyl ether (DME) and HFCs (hydrofluorocarbons).

Because of its high solvency and easy reformulation in water-based products, DME is important in uses such as water-based paints, hair sprays and perfumes. However, DME's strong solvency means that filling equipment, container material and gaskets have to be resistant to dissolution or deterioration. DME is more expensive than hydrocarbons, and, like them, is flammable—requiring additional safety precautions for handling, storage, transportation and filling. Such disadvantages effectively limit its use as a CFC replacement to a few applications.

Hydrofluorocarbons such as HFC-134a and HFC-227ea are replacing CFC propellants in some specific aerosol products—mainly pharmaceuticals, some solvent cleaning sprays, lubricants and other products. However, although they are non-flammable, non-toxic liquids, they work at higher pressure than CFCs and in some cases require modifications to filling equipment. Moreover, being greenhouse gases, HFCs are regulated under the Kyoto Protocol and therefore can be used only for applications where no other alternatives are readily available.

The characteristics of hydrocarbons—zero ozone-depleting potential, widespread availability, low cost, low toxicity and good dispersion—make them the most common substitute for CFCs as aerosol propellants. They account for 96 per cent of world-wide conversion from CFCs in the sector. The most frequently used are propane, n-butane and isobutane. They derive from liquefied petroleum gases (LPGs) which contain varying levels of unsaturated hydrocarbons, sulphur compounds, water and other impurities—contaminants that have to be removed from the gas to various grades including aerosol

grade for most applications. Thus, although hydrocarbons are widely sold as LPG for fuel, many developing countries do not have butane or propane of suitable quality to be used as a feedstock for purification to aerosol propellant grade. They therefore either have to be imported in the same way as CFCs, or the gas purification equipment has to be purchased.

The most serious disadvantage of hydrocarbons is their high flammability, which requires safety precautions for all aspects of their use including transportation, handling, storage and filling. Safe facilities must be explosion- and fire-proof and have adequate ventilation. Employees also require additional training in handling flammable substances. Both gas purity and safety requirements thus constitute the key issues to be addressed while transferring this CFC substitute technology to the end users.

### ***UNIDO-managed technology transfer***

UNIDO has actively formulated and implemented investment projects in the aerosol sector since it became an implementing agency of the Montreal Protocol in 1993. Table 5 illustrates the share of UNIDO aerosol investment projects approved as of the 35<sup>th</sup> Executive Committee session of December 2001. It shows that of the total 105 aerosol projects approved in 1992-2001, 44 (42 per cent) were formulated and submitted by UNIDO. From the total budget of \$26.6 million allocated for implementation of these projects by the Multilateral Fund, UNIDO's share was 29.7 per cent, or \$7.9 million. The significant role of UNIDO in aerosols is also evident in the 29.7 per cent share approved by the Multilateral Fund for UNIDO projects compared to its 24.5 per cent share in the total investment project fund. Because most of them are developed for small and medium scale enterprises, the cost effectiveness (dollars per kg ODP phased out) of UNIDO projects is higher than the average for the sector. Nevertheless UNIDO spends only \$2.27 to phase out one kg of ODS, which is half the adopted threshold for the sector (\$4.4 per kg).

Geographically, most of the MLF-approved UNIDO investment projects have been developed for Africa (Algeria, Cote d'Ivoire, Kenya, Nigeria, Sudan, Tanzania and Tunisia). Others were for West Asia (Lebanon, Jordan, Syria and Yemen) and Eastern Europe (Croatia, Macedonia and Romania). The main conversion technology transferred to end-users in these countries replaced CFC propellants with hydrocarbon aerosol propellants (HAPs). In a few cases, CFC was replaced by both HAP and non-flammable HFC-134a (specified for pharmaceutical products).

Conversion to HAP-based technology involves the provision of relevant advice and services on the proper composition of aerosol products to be gassed with the ODS-free propellant, corresponding modifications to the aerosol plant layout and the civil engineering works to be carried out at the project site. It also includes the supply of eligible equipment items and safety devices as well as their installation, testing and commissioning and training of counterpart personnel involved in maintenance and production operations.

**Table 5 UNIDO aerosol projects funded by the MLF**

Item	UNIDO		Multilateral Fund	
	Total	Share of total (%)	Total	Share of total (%)
ODP phased out (aerosols), tons	3,477	11	24,902	12
Funds approved (aerosols) - \$ millions	7.9	3	26.6	3
Average cost effectiveness (aerosols), \$/kg	2.27		1.07	
Funds for UNIDO aerosol projects compared to the total funds approved for aerosol sector for all Implementing Agencies				29.73
Number of UNIDO aerosol projects compared to the total number of projects approved for aerosol sector for all implementing agencies				42
Share of UNIDO in the total investment project fund approved for all Implementing Agencies				24.45

Source: 35<sup>th</sup> MLF Executive Committee, December 2001.

Because of the low cost of hydrocarbon propellants, savings in operating costs in aerosol production are an advantage for that particular technology in aerosol plant conversion. On the other hand, at the conversion project implementation stage, established procedures require that the calculated incremental operating savings should be deducted from the costs of eligible equipment items and safety devices to be supplied to a counterpart, thus reducing the amount of funds allocated to a project.

### ***Safety and product quality***

Aerosol production technology involves operations such as filling of a liquid product concentrate into a can, inserting and crimping (hermetically sealing) of an aerosol valve to its top, and subsequent gassing of the can with a propellant. To perform these operations, aerosol plants have to be equipped with baseline and auxiliary equipment and the average production line is composed of ten to twenty pieces of equipment linked together by conveyors. Irrespective of the production capacity and the level of automation, the baseline equipment always includes components such as product filling, valve crimping and propellant gassing units and interconnecting conveyors as well as propellant feedstock (cylinders or bulk storage tanks) and pumps delivering the propellant to the gassing unit.

Being non-flammable and non-toxic, CFC propellants did not require specific safety measures for their storage, handling and use in the aerosol can gassing operation. All the above equipment could be easily placed in the same production area. In contrast, the major issue with HAP-based technology is its use of highly flammable hydrocarbon propellant. Conversion of production facilities to HAP duty therefore always calls for specific safety measures and equipment, as well as special training of the personnel involved in HAP transportation, storage, handling and filling operations. To minimize accident risks and to ensure safe operation of the aerosol production line, the conversion process starts with modification of the aerosol plant layout and subsequent repositioning of the baseline production equipment. A gasser that is specifically designed for HAP gassing operations replaces the CFC propellant gassing unit. The HAP gassing operation is performed in a



space separated from the main production area where aerosol cans are filled with a product and crimped. This is achieved by placing a HAP gassing machine either in an open air filling room with sufficient natural ventilation, or in a special enclosure equipped with safety devices and ventilation system and explosion-proof lighting and electrical equipment. The safe use of HAP-based technology also requires installation of additional fire fighting equipment and, together with automatic flammable gas detection and monitoring systems placed in the HAP bulk storage area, the gassing enclosure and production area. Proper training of the project beneficiary personnel in safe handling of the equipment is an indispensable, integral part of the technology transfer, and all projects formulated and implemented by UNIDO in Article 5 countries provide this service to the technology end users.

To maintain product quality, converting an aerosol plant to HAP-based technology also involves reformulating the aerosol product composition. Except in those cases where a project beneficiary possesses the experience and laboratory equipment to perform the required tests, relevant advice on proper composition of aerosol products gassed with HAP is usually provided by UNIDO. Proper composition of an aerosol product is an essential technology transfer element that allows the project beneficiary to maintain and/or improve the quality. This has a positive impact on enterprise competitiveness and its ability to keep and/or enhance its local market share as well as an opportunity to enter international markets.

Another factor in the quality of products is the purity level of the propellant used in the gassing operation. It should be aerosol grade (odorless), which in most cases is not available locally. To ensure the required purity, beneficiary enterprises are supplied with de-stenching columns with molecular sieve filters and gas purity measuring instruments. Also included in the scope of UNIDO delivery is a hot water test bath in which the filled and gassed cans are placed to check the quality of the final product. Other expertise, equipment and services provided by UNIDO allowed enterprises to apply for and be certified to both ISO 9000 and ISO 14000 standards.

### ***Technology transfer to SMEs***

Most of the beneficiaries of the 44 aerosol projects formulated by UNIDO and approved by the Multilateral Fund are SMEs employing from 5 to 50 workers and producing from 1 to 4 million aerosol cans per year. The small ones often have very basic equipment composed of manual filling, crimping and gassing machines and propellant feeding pumps driven by non-explosion proof motors. In addition, some of them are located in congested areas where conversion to flammable propellants can be very dangerous.

The most suitable solution is relocation of the aerosol plant to a safe area. UNIDO services therefore include advice on the aerosol plant layout, the civil engineering works and the required electricity, water and compressed air supply. Those services, together with procurement, delivery, installation and testing of new equipment, and training of the counterpart personnel, ensure a smooth transfer of the HAP based technology to SMEs.

**Acknowledgements**

This document was prepared by the United Nations Industrial Development Organization, Programme Development and Technical Cooperation Division, Multilateral Environmental Agreements Branch.

Produced with the support of Documents Control, United Nations Office Vienna  
Cover design by Electronic Publishing Unit, United Nations Office Vienna  
Printed by Printing Unit, International Atomic Energy Agency, Vienna, Austria.



UNITED NATIONS INDUSTRIAL DEVELOPMENT ORGANIZATION  
Multilateral Environmental Agreements Branch  
Programme Development and Technical Cooperation Division  
Vienna International Centre, P.O. Box 300, A-1400 Vienna, Austria  
Telephone: (+43-1) 26026-4714, Fax: (+43-1) 26026-6804  
E-mail: [unido@unido.org](mailto:unido@unido.org), Internet: <http://www.unido.org>