



TOGETHER
for a sustainable future

OCCASION

This publication has been made available to the public on the occasion of the 50th anniversary of the United Nations Industrial Development Organisation.



TOGETHER
for a sustainable future

DISCLAIMER

This document has been produced without formal United Nations editing. The designations employed and the presentation of the material in this document do not imply the expression of any opinion whatsoever on the part of the Secretariat of the United Nations Industrial Development Organization (UNIDO) concerning the legal status of any country, territory, city or area or of its authorities, or concerning the delimitation of its frontiers or boundaries, or its economic system or degree of development. Designations such as “developed”, “industrialized” and “developing” are intended for statistical convenience and do not necessarily express a judgment about the stage reached by a particular country or area in the development process. Mention of firm names or commercial products does not constitute an endorsement by UNIDO.

FAIR USE POLICY

Any part of this publication may be quoted and referenced for educational and research purposes without additional permission from UNIDO. However, those who make use of quoting and referencing this publication are requested to follow the Fair Use Policy of giving due credit to UNIDO.

CONTACT

Please contact publications@unido.org for further information concerning UNIDO publications.

For more information about UNIDO, please visit us at www.unido.org

22837

BUILDING CONSTRUCTION
UNDER SEISMIC CONDITIONS
IN THE BALKAN REGION

VOLUME 6

REPAIR
AND STRENGTHENING
OF HISTORICAL
MONUMENTS
AND BUILDINGS
IN URBAN NUCLEI

**BUILDING CONSTRUCTION
UNDER SEISMIC CONDITIONS
IN THE BALKAN REGION**

UNDP/UNIDO PROJECT RER/79/015

VOLUME 6

**REPAIR
AND STRENGTHENING
OF HISTORICAL
MONUMENTS
AND BUILDINGS
IN URBAN NUCLEI**



UNITED NATIONS INDUSTRIAL DEVELOPMENT ORGANIZATION
executing agency for the
UNITED NATIONS DEVELOPMENT PROGRAMME
Vienna, 1984

VOLUME 6

REPAIR AND STRENGTHENING OF HISTORICAL MONUMENTS AND
BUILDINGS IN URBAN NUCLEI

Working Group

George Gr. Penelis, Convenor
Vesselin Venkov
Costas Zambas
Bela Csak
Traian Popp
Dogan Kuban
Drazen Anicic

Chief Technical Adviser

Jack G. Bouwkamp

Consultant

Roland J. Mainstone

UNIDO Backstopping Officer

Emanuel Csorba

TABLE OF CONTENTS

	PREFACE	vii
	NOTE ON THIS VOLUME	ix
1.	INTRODUCTION	1
2.	OBJECTIVES AND NECESSARY ACTIONS BEFORE AND AFTER AN EARTHQUAKE	3
	2.1 Objectives in repair and strengthening	3
	2.2 Actions before an earthquake	6
	2.3 Actions after an earthquake	12
	2.4 The task of the structural engineer	15
3.	TYPICAL STRUCTURAL FORMS AND THEIR SEISMIC BEHAVIOUR	17
	3.1 Materials and loading	17
	3.2 Columns	17
	3.3 Walls and piers	21
	3.4 Foundations	34
	3.5 Beams and lintels	34
	3.6 Trusses	34
	3.7 Arches	40
	3.8 Vaults	43
	3.9 Domes, semidomes, pendentives, and squinches	43
	3.10 Ties	47
	3.11 Buttresses	50
	3.12 Classical temples and colonnades	53
	3.13 Arcades	58
	3.14 Halls with open non-thrusting timber roofs	61
	3.15 Vaulted halls	63
	3.16 Centrally planned domed structures	64
	3.17 Minarets and towers	69
	3.18 Multi-storey buildings	74
4.	METHODS OF INVESTIGATION AND ANALYSIS	79
	4.1 Visual inspection	79
	4.2 Structural survey	81
	4.3 Continued recording, tests on materials and soils, etc.	83
	4.4 Estimation of seismic hazard	88
	4.5 Analysis of structural response	89
	4.6 Static analysis	89
	4.7 Dynamic analysis	95
	4.8 Safety coefficients	95
5.	METHODS OF EMERGENCY INTERVENTION, REPAIR, AND STRENGTHENING	97
	5.1 Emergency interventions	97
	5.2 Partial demolition for repair and reconstruction	105
	5.3 Materials for repair and strengthening	105
	5.4 Local repairs	110
	5.5 Reconstruction of dismantled or fallen masonry or timber	116
	5.6 Local strengthening	116

5.7	Overall strengthening above ground	127
5.8	Strengthening of foundations	137
6.	BIBLIOGRAPHY AND SOURCES	141
6.1	Bibliography	141
6.2	Sources for the text	142
6.3	Sources for the illustrations	143
7.	CASE STUDY: THE ERECHTHEION, ATHENS	145
7.1	Introduction	145
7.2	Description	145
7.3	Structural condition	145
7.4	Detailed investigations	152
7.5	Repair and strengthening	155
7.6	Sources	163
8.	CASE STUDY: THE ROTUNDA, THESSALONIKI	165
8.1	Introduction	165
8.2	Description	165
8.3	Structural condition	168
8.4	Emergency works	168
8.5	Detailed investigations	169
8.6	Repair and strengthening	181
8.7	Specification and execution	187
8.8	Sources	187
9.	CASE STUDY: THE CHURCH OF HAGIOS ANDREAS, PERISTERA	189
9.1	Introduction	189
9.2	Description	189
9.3	Structural condition	191
9.4	Detailed investigations	191
9.5	Repair and strengthening	194
9.6	Specification	195
9.7	Sources	195
10.	CASE STUDY: THE BOYANA CHURCH, SOFIA	197
10.1	Introduction	197
10.2	Description	197
10.3	Structural condition	199
10.4	Detailed investigations	199
10.5	Repair and strengthening	201
10.6	Sources	202
11.	CASE STUDY: THE CATHEDRAL, DUBROVNIK	205
11.1	Introduction	205
11.2	Description	205
11.3	Structural condition	206
11.4	Detailed investigations	206
11.5	Repair and strengthening	209
11.6	Sources	210
12.	CASE STUDY: THE CALVINIST CHURCH, BEKES	215

12.1	Introduction	215
12.2	Description	215
12.3	Structural condition	216
12.4	Detailed investigations	216
12.5	Repair and strengthening	220
12.6	Sources	224
13.	CASE STUDY: THE MINARET OF EGER	225
13.1	Introduction	225
13.2	Description	225
13.3	Structural condition	227
13.4	Detailed investigations, 1970	228
13.5	Strengthening, 1970	229
13.6	Subsequent dynamic analysis, 1983	231
13.7	Sources	236
14.	CASE STUDY: FREE-STANDING DEFENCE WALLS	239
14.1	Introduction	239
14.2	Description	239
14.3	Structural condition	239
14.4	Detailed investigation	243
14.5	Repair and strengthening	246
14.6	Sources	246
15.	CASE STUDY: THE RECTOR'S PALACE, DUBROVNIK	251
15.1	Introduction	251
15.2	Description	251
15.3	Structural condition	252
15.4	Detailed investigations	252
15.5	Repair and strengthening	256
15.6	Sources	263
16.	CASE STUDY: THE MARITIME MUSEUM, KOTOR	265
16.1	Introduction	265
16.2	Description	265
16.3	Structural condition	267
16.4	Detailed investigations	267
16.5	Repair and strengthening	267
16.6	Sources	269
17.	CASE STUDY: THE HEGEMONEION, KARLOVASI, SAMOS	271
17.1	Introduction	271
17.2	Description	271
17.3	Structural condition	274
17.4	Detailed investigations	274
17.5	Repair and strengthening	276
17.6	Sources	279
18.	CASE STUDY: BUILDINGS OF LESS INDIVIDUAL IMPORTANCE	281
18.1	Introduction	281
18.2	Overall considerations including seismic hazard	283
18.3	Building in Ulica Pracata, Dubrovnik	283

18.4	Buildings in Budva	285
18.5	Rural dwelling house in Lusevera (Friuli)	291
18.6	Timber framed dwelling houses	294
18.7	Sources	296

PREFACE

The Regional Project, "Building Construction under Seismic Conditions in the Balkan Region", UNDP/UNIDO RER/79/105, has been carried out with the participation of the Governments of Bulgaria, Greece, Hungary, Rumania, Turkey, and Yugoslavia, and with the United Nations Industrial Development Organisation acting as Executing Agency for the United Nations Development Programme. Mr J.G. Bouwkamp served as Chief Technical Advisor.

Within the framework of the Project, a set of seven manuals has been produced, reflecting to a considerable extent the experience of the participating nations in earthquake resistant design and construction. These Manuals were developed by the National Delegates of the Project Working Groups, the Chief Technical Advisor, and the Consultants.

The following manuals have been produced:

- Volume 1 : Design and Construction of Seismic Resistant Reinforced Concrete Frame and Shear-Wall Buildings
- Volume 2 : Design and Construction of Prefabricated Reinforced Concrete Building Systems
- Volume 3 : Design and Construction of Stone and Brick-Masonry Buildings
- Volume 4 : Post-Earthquake Damage Evaluation and Strength Assessment of Buildings under Seismic Conditions
- Volume 5 : Repair and Strengthening of Reinforced Concrete, Stone and Brick-Masonry Buildings
- Volume 6 : Repair and Strengthening of Historical Monuments and Buildings in Urban Nuclei
- Volume 7 : Seismic Design Codes of the Balkan Region.

ACKNOWLEDGEMENTS

The financial support of the United Nations and the Governments of Bulgaria, Greece, Hungary, Rumania, Turkey, and Yugoslavia should hereby be acknowledged. Also the cooperation of the National Science Foundation of the USA is noted with appreciation.

The Project has been directed by the Project Coordinating Committee. The membership of the Committee was as follows:

Bulgaria	G. Brankov
Greece	Th. Tassios and J. Sbokos
Hungary	F. Hunyadi
Rumania	V. Cristescu
Turkey	M. Erdik
Yugoslavia	N. Vukotic

From the United Nations the following individuals participated in the deliberations of the Coordinating Committee:

- O.A. Nordstrand - UNDP, Athens, Greece, Resident Representative and UNDP Principal Project Representative,
- E. Csorba - UNIDO, Vienna, Austria, Senior Industrial Development Officer, and
- J.G. Bouwkamp - UNIDO, Thessaloniki, Greece, Chief Technical Advisor.

DISCLAIMER

The material contained in these volumes includes detailed findings in earthquake engineering - particularly, objective evaluations of causes and effects in earthquake damage - and in the seismic and geological characteristics of the physical environment.

The material reflects the interpretation of the authors and contributors and does not necessarily represent the viewpoint of the United Nations Industrial Development Organisation, the United Nations Development Programme, the participating Governments, and the National Science Foundation of the USA. The above mentioned Governments and Organisations - while providing for the presentation of these Volumes in the public interest and for their obvious informational value - assume no responsibility for any views expressed therein.

The Governemnts and Organisations do not approve, recommend, or endorse any proprietary product or proprietary material mentioned in this publication. No reference shall be made to the Governments or Organisations mentioned above, that would indicate or imply - directly or indirectly - that the Governments and Organisations mentioned above approve or disapprove of the use of any proprietary product or proprietary material mentioned herein.

The description and classification of countries and territories in these publications and the arrangement of material do not imply the expression of any opinion whatsoever on the part of the secretariat of UNIDO concerning the legal status of any country, territory, city or area, or its authorities, or concerning the delimitation of its frontiers or boundaries.

This publication has been reproduced without formal editing by UNIDO.

NOTE ON THIS VOLUME

This Manual is the sixth volume of the seven listed on page vii and developed under UNDP/UNIDO Project RER/79/015 "Building Construction under Seismic Conditions in the Balkan Region". It has been prepared in consultation with Project Working Group F on "Assessment of Earthquake Resistance, Strengthening and Repair of Cultural and Historical Monuments and Urban Nuclei" and on behalf of that Working Group by the Consultant to the Group. It aims to provide engineers and associated professionals in the Balkan region particularly, but also in other earthquake-prone areas, with relevant information and guidance based on the experience gained after some recent strong earthquakes in the Balkan region and elsewhere and on other recent experience, investigation, and thinking related to the special problems posed by historical monuments and other old buildings. This aim is more fully explained in the introduction.

The content of the Manual stems initially from the National Reports of the participating countries as presented at the first two Working Group Meetings in Thessaloniki (in March 1982) and Istanbul (in December 1982 - when the first part of the meeting took the form of a three-day joint seminar with Project Working Group C on "Stone and Brick-Masonry Structures"). On the basis of the discussions at the second meeting, the Consultant prepared a draft outline of the Manual. This was discussed at the third (and last) full Working Group Meeting in Thessaloniki (in March 1983). The Consultant was then authorised to produce the final version, incorporating further material promised by Working Group members, particularly for the Case Studies. During the production of this final version, one more meeting was held between the Convenor, the Yugoslav National Delegate, and the Consultant to agree the content of chapters 2, 4, 5, and of all Case Studies for which the National inputs had been received. Drafts of these chapters were also sent to all other Working Group members, as were drafts of Case Studies as appropriate, and these were discussed individually with some members in Athens (in September 1983) and in Venice (later in September 1983 before the small meeting just referred to). The Consultant was also grateful for the comments of Dr Bernard Feilden, Past Director of ICCROM, to whom the draft chapters 2, 4 and 5 were shown in Athens. All contributions by Working Group members and others that were used in the final version of the Manual are acknowledged in chapter 6 or, if used in Case Studies, at the ends of these studies. Where no source is acknowledged, the Consultant must take primary responsibility, though all recommendations were discussed and agreed as stated above. He would like here to express his thanks to all Working Group members for their trust and for the freedom that they gave him to develop the Manual as a coherent whole, even though this meant omitting some contributions for the sake of overall balance and greatly abbreviating others.

The Working Group consisted of the National Delegates of the participating countries with Professor George Gr. Penelis, Aristoteles University of Thessaloniki, Greece, serving as Convenor. Other members of the Working group were: Professor Vesselin Venkov, University of Architecture and Civil Engineering, Sofia, Bulgaria; Costas Zambas, Civil Engineer, Technical Office for the Preservation of the Acropolis Monuments, Athens, Greece; Dr Bela Csak, Associate Professor, Technical University of Budapest, Hungary; Dr Traian Popp, Consulting Engineer, Design Institute "Carpati", Bucarest, Rumania; Professor Dogan Kuban, Technical University, Istanbul, Turkey; and Professor Drazen Anicic, University of Zagreb, Yugoslavia.

Consultant to the Working Group was Dr Rowland J. Mainstone, Consulting Engineer and Visiting Professor, University College, University of London, England.

The Working Group and the Consultant would like to express their gratitude for the contributions and assistance of Küksal Anadol, Yapi Merkezi, Istanbul; Poul Beckmann, Ove Arup & Partners, London; Androniki Miltiadou, Athens; Professor Graham Powell, Berkeley; Asst. Professor Alexander Rachev, Sofia; Miha Tomazevic, Ljubljana; Dr M. Velkov, IZIIS, Skopje; Professor Müfit Yorulmaz, Istanbul; and Mihaela Zamolo, Zagreb, and to the Chief Technical Adviser for his guidance and assistance.

1. INTRODUCTION

The structures dealt with in this manual are all those which merit special care on account of their individual historical or architectural importance, their significance as surviving representatives of an earlier tradition, or their value as components of a larger group such as an old-established urban nucleus.

Assessment of the earthquake resistance of such structures presents special problems on account of the ways in which they were built and the materials used. These problems may be accentuated by complex past histories of successive changes and progressive deterioration. When devising methods of repair or strengthening, there will also be a need to adopt a more cautious approach than that which would normally be adequate for a modern structure, and to look further ahead.

Even though the focus is on a limited geographic region, the number of structures to be considered is large, and they embrace a wide range of structural forms, sizes, and materials used. On the one hand are unique monuments like those on the Acropolis in Athens. On the other are many modest and more recent dwellings and public buildings in both town and country. With the latter, wider considerations of group value and social and economic policy are likely to be more important than the conservation of the individual structures. From the structural point of view, it is nevertheless necessary to look chiefly at the individual structures in all cases, since it is these, one by one, which must be given the capacity to resist a future earthquake.

The manual is therefore concerned largely with individual structures, after noting the contexts in which those which are valuable chiefly as components of a group should be considered.

It is also addressed primarily to engineers and is concerned specifically with repair and strengthening to meet a seismic hazard rather than with repair and strengthening in general. It is stressed that architectural, archaeological, and other aspects should be taken fully into account in the assessments made and the choice of what is to be done. Indeed it is recommended that no engineer should undertake alone works of this nature. He should always seek the advice of, and work in close collaboration with, architects and archaeologists or other professionals with relevant complementary expertise. But these non-structural aspects are not, therefore, a direct concern.

It is felt, however, that collaboration between the professions may be more effective and fruitful if each has some understanding of the others' aims, needs, and approaches, and of the choices open to them. In the hope of contributing to this understanding, an attempt has been made to make the explanations that are given as widely intelligible as possible.

The manual proper opens with discussions of general principles, of the actions which are desirable before and after an earthquake, and of the task of the structural engineer. Chapter 3 describes the structural forms that are found and their responses to earthquake loading. Chapters 4 and 5 then describe the available methods for the assessment of needs for repair and strengthening and for the actual works that must be undertaken.

The manual concludes with a number of case studies of works recently undertaken in several Balkan countries. It is not claimed that they represent

the best that could be done in every instance. That would be unwise when there is still much to be learnt and when most of the works described have yet to be tested by another earthquake. But they do illustrate many of the methods and overall approaches described in the preceding chapters, and they have been included primarily for this purpose. They have been selected to cover also a wide range of structural types and requirements.

2. OBJECTIVES AND NECESSARY ACTIONS BEFORE AND AFTER AN EARTHQUAKE

2.1 Objectives in repair and strengthening

The engineer will be concerned primarily with giving the structures that are discussed here the ability to withstand future earthquakes without excessive damage. In this respect, his objective will differ from the usual one that is applicable to other existing structures only in that there may be other criteria of acceptable damage and in that a longer return period may have to be envisaged for the design earthquake.

Alongside this primary objective he must, however, take into account others which stem from the particular characteristics and values that make these structures (or groups of structures) worthy of special attention. This imposes upon him, in consultation with other specialists, a duty to:

- identify the particular characteristics and values.
- consider what limitations these place on the choice of methods of repair and strengthening.

Possible values, consequent limitations on choice, and appropriate structural design criteria are discussed further in the next few paragraphs.

2.1.1 Characteristics and values to be considered

These may include any of the following:

- a symbolic value stemming from the beliefs or purposes that gave rise to the original construction, or from subsequent uses or events. A temple, church, mosque, or shrine will have such a value by design. Other structures may subsequently acquire it as a result of the accidents of history.
- an aesthetic value as a consciously created work of art or (more by accident perhaps) as an important feature in the landscape or townscape.
- a related importance stemming from contents or decorations that are themselves of aesthetic value - such as cycles of fresco or mosaic.
- a 'documentary' value as physical evidence of outstanding architectural and/or structural creativity, or (in a more representative manner) of the architectural or structural practices of a particular time and place.
- a secondary 'documentary' value in relation to particular historical events, religious rituals, etc.
- a social function - as a focus of community life for instance.
- a value as part of a group of structures which, together, have one or more of the above values.

2.1.2 General principles of action: the Venice Charter

Bearing in mind this wide range of values, an international meeting of experts concerned with historical structures agreed, in 1964, on a number of general principles of action. These were embodied in a document known as the Venice

Charter. Though they were not specifically concerned with action after an earthquake, those headed RESTORATION are all relevant:

Article 9 - The process of restoration is a highly specialised operation. Its aim is to preserve and reveal the aesthetic and historical value of the monument and is based on respect for original material and authentic documents. It must stop at the point where conjecture begins, and in this case moreover any extra work which is indispensable must be distinct from the architectural composition and must bear a contemporary stamp. The restoration in any case must be preceded and followed by an archaeological and historical study of the monument.

Article 10 - Where traditional techniques prove inadequate, the consolidation of a monument can be achieved by the use of any modern technique for conservation and construction, the efficacy of which has been shown by scientific data and proved by experience.

Article 11 - The valid contributions of all periods to the building of a monument must be respected, since unity of style is not the aim of a restoration. When a building includes the superimposed work of different periods, the revealing of the underlying state can only be justified in exceptional circumstances and when what is removed is of little interest and the material which is brought to light is of great historical, archaeological or aesthetic value, and its state of preservation good enough to justify the action. Evaluation of the importance of the elements involved and the decision as to what may be destroyed cannot rest solely on the individual in charge of the work.

Article 12 - Replacements of missing parts must integrate harmoniously with the whole, but at the same time must be distinguishable from the original so that restoration does not falsify the artistic or historical evidence.

Article 13 - Additions cannot be allowed except in so far as they do not detract from the interesting parts of the building, its traditional setting, the balance of its composition and its relation with its surroundings.

In relation to partly ruined structures, Article 15 added:

Ruins must be maintained and measures necessary for the permanent conservation and protection of architectural features and of objects discovered must be undertaken. Furthermore, every means must be taken to facilitate the understanding of the monument and to reveal it without ever distorting its meaning. All reconstruction work should however be ruled out a priori. Only anastylosis, that is to say, the reassembling of existing but dismembered parts can be permitted. The material used for integration should always be recognisable and its use should be the least that will ensure the conservation of a monument and the reinstatement of its form.

Finally article 16 called for full and precise documentation of all stages of the work undertaken and of all technical and formal features identified in the course of the work, and for the safe deposit of the record.

The meeting did not specifically consider structures whose value stemmed less from their individual characteristics than from their membership of a larger group. For such structures, some of the principles may not apply with the

same force. In any particular case, their relevance will depend on the values considered to be important.

2.1.3 Choice of techniques

Article 10 of the Charter is the most directly relevant to the choice of techniques for repair and strengthening in a seismic environment.

Modern techniques are admissible where they are adequately proven for the particular use intended and adequate capacity cannot be ensured by traditional techniques. But caution is called for by the requirement that they should be adequately proven, in view of the long life that is required. Proof of durability may be difficult without longer experience of use than will yet be available.

Where there is no satisfactory alternative to the use of a technique that is not adequately proven, this technique should be used only in a manner that will permit easy corrective action at a later date if necessary. What is done should be easily undone with the minimum hurt to the original fabric. The use of traditional techniques and materials characteristic of the original structure or others of its period is clearly preferable, bearing in mind the principle behind Article 12 - namely that there should be no deception or falsification through their use.

Articles 11 and 13 have a less direct relevance to any works that involve a change in the structural form.

When parts of the surviving structure are removed (perhaps to reduce mass or to give a better distribution of stiffness or strength), some evidence of the past history of the structure will be destroyed. This will also happen even if parts are merely moved - as when leaning walls or columns are pushed back to the vertical. In such cases there is a particularly strong need for a precise record of the condition before the change if the past history is important, or may in the future be thought to be.

Additions are less likely to destroy evidence of past history, except where substantial cutting into the surviving structure is necessary to accommodate them. Additions of ties and buttresses were, moreover, fairly common in the past. To make similar additions today with due sensitivity to their aesthetic effects may, therefore, be the best way of conforming to a historical pattern of response to structural need if it avoids a more substantial structural change.

In the case of smaller structures, similar considerations apply if they are important representatives of a particular traditional type. If their value stems only from their contributions to the overall character of an urban group, a freer choice of technique will be admissible.

Article 15 should be read as including whatever measures are necessary to protect and safeguard fresco or mosaic decoration. This may exclude the use of some strengthening techniques because they could cause damage.

This article also explicitly covers anastylosis, which is strictly relevant only to structures already partly or wholly dismembered. But it may be read as including the prior dismantling of parts of structures so built that re-erection is possible without significant loss if this is the only feasible way of undertaking essential local repairs, inserting essential reinforcement, or rectifying errors in a previous intervention. It is applicable,

in this sense, chiefly to structures originally built of timber or of well squared blocks of dressed stone.

2.1.4 Structural criteria and the need to look ahead

In all design it is necessary to look ahead and to consider a wide range of criteria, both structural and non-structural. Normally the ideal will be to achieve an acceptable level of performance over the expected life with an acceptably low risk of failure under abnormal loads such as those due to earthquake and no excessive need for maintenance. The life may not be considered explicitly. Where it is, it is likely to be around 50 - 100 years.

In repairing and strengthening cultural and historical monuments and (to a less extent) other structures in important urban nuclei, a similarly wide range of criteria must be considered. But it is necessary to look further ahead and to eliminate, as far as possible, the need for future remedial intervention. The fact that the structures already exist and have, usually, already existed for much longer than the life normally envisaged for new structures also substantially changes the design problem. Allowance must still be made for unknowns. But they are not now the same unknowns. The criteria stated in normal Codes of Practice are not, therefore, relevant.

Such Codes are, in any case, framed for types of construction common today rather than those used in the past, which further limits their applicability. Usually they will be applicable, in this respect, only to some of the newer dwellings and public buildings in urban nuclei and to older ones only after these have been extensively modified.

In terms of safety levels, it seems reasonable that all dwellings and public buildings intended to remain in use should, when they are restored after earthquake damage, be brought up to levels not less than those specified for new construction for the same uses. For older historical monuments it is desirable to consider a longer return period when estimating future seismic loadings. At the same time it should be recognised that the survival of the structure hitherto demonstrates structural capacities that may not be easy to demonstrate by present methods of analysis. Also the primary concern is more likely to be the limitation of future damage than the usual considerations of public safety.

2.2 Actions before an earthquake

Earthquakes strike unannounced. This makes it impossible to identify, among the very large numbers of structures at risk, those most likely to be hit next and to divert the available resources to repairing and strengthening these structures in advance. Such preventive interventions are feasible, in practice, only to a very limited extent and on the basis of some different assessment of priorities. But there are several other types of action that are both feasible and desirable. Most are already in progress in individual countries, and it is strongly recommended that all should be actively pursued with the necessary Governmental backing.

2.2.1 Inventories of structures at risk and assessments of priorities for further action

National inventories of structures at risk are highly desirable, both for immediate reference after an earthquake and to assist in planning other desirable action beforehand. For the latter purpose, some assessment of the

level of risk is desirable, and a first indication of this will be given by the location on a seismic zoning map. All major cultural and historical monuments should be individually listed. Initially it will, however, be sufficient to list together groups of similar structures that make up important urban nuclei, and to identify and list typical traditional types of construction for these and other smaller structures, together with the areas where these types are chiefly found. For ease of listing and subsequent reference, a simple coded nomenclature will be useful. Figures 2.1 and 2.2 illustrate such a nomenclature applied to a number of mediaeval and Ottoman monuments in Turkey.

To assist in determining priorities for other action, these inventories should include also some assessments (provisional and tentative if necessary in the first place) of the relative importance of the structures listed and their present states of repair and likely seismic behaviour. These assessments may be possible from existing records. If not, they will have to be based on visual inspections in the field.

Since different types of further action are possible (as discussed in the following sections) priorities will have to be considered afresh in relation to each.

The actual determination of priorities will present little difficulty where all indications - high importance coupled with high seismic risk for instance - point in the same direction. It will be more difficult when it is necessary to balance claims of higher importance of one structure against those of higher risk to another. In practice, those responsible will have to make the best judgements they can from the broadest possible standpoint, and paying attention to the resources likely to be available for further action.

2.2.2 Surveying and recording of structures at risk

Full architectural measured surveys, supplemented by good photographic coverage, are desirable for all major monuments and for representative examples of other structures. Where they do not already exist, the lack should be made good. See Figure 2.3.

Materials, significant structural details, evidence of past structural changes, and evidence of present structural condition should also be recorded. Evidence of past structural changes may include changes in material, construction technique, or architectural character. Such changes may also be betrayed by incompatible structural deformations such as incompatible inclinations from the vertical of adjacent sections of wall or pier. Evidence of present structural condition should include displacements, cracks, weathering or other deterioration of materials, and the condition of important structural joints and connections - for example of the anchorage of ties and of the joints of timber frames. This should be typical evidence where it relates to representative examples from a group of structures.

Where there is prima facie evidence from the above records, or from poor foundation conditions, of a considerable risk of serious damage in a future earthquake, structural analysis is also desirable to assess the risk.

2.2.3 Studies in support of future structural interventions

To assess strength and stability and likely response to a future earthquake, much information is required about the properties of materials and structural elements, and suitable methods of analysis must be available.

Materials

S stone
 BR brick (BR_b-baked brick BR_m-mud brick)
 T timber
 E earth

Load Bearing walls

SW_d Stone wall of dressed stone (or ashlar)
 SW_{dr} Stone wall of dressed stone with rubble core
 SW_r Rubble stone wall

Timber structure with or without infill

T_b Timber with brick infill
 T_a Timber with stone infill
 T Timber without infill

Single support (interior)

S_p Stone pier
 S_c Stone column
 T_c Timber column

Horizontal Tie elements

S_a Stone arch
 BR_a Brick arch
 (if mixed SB or BS depending the priority
 given to any one material)
 T_{bm} Timber beam
 T_t Timber truss

Elements of transition

P_d Pendentive
 S_q Squinch
 T_r Turkish triangle

Roofing

S_v Stone vault
 B_v Brick vault
 S_d Stone dome
 B_d Brick dome
 T_{bm} Timber beam
 T_t Timber truss

Roof Insulation

R_e Flat earthen roof
 R_t Tiled roof
 R_l Lead covered

If the foundations are of dressed stone, they are indicated F_d

The two numbers added to the formula between parenthesis are:
 the first number max free height of vertical supports
 the second number max opening

Example:

Karaman, Arapzade Mosque

SW_r-SBR_a-T_b-E (x, y)

2.1 Nomenclature for the Mediaeval and Ottoman monuments of Turkey

- o The Mosque Gökmedrese (A.D. 13th C)

$F_d + SW_{dr} + P_d + B_v + R_e$ x: 5.00 m. y: 7.00 m.

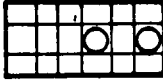

- o The Hospital Bimarhane (A.D. 1308)

$F_d + SW_{dr} + P_d + T_q + B_d + R_e$ x: 7.00 m. y: 6.90 m.



- o The so called Tomb of Sultan Mesut (A.D. 14th C)

$F_d + SW_{dr} + B_v$ x: 6.00m. y: 5.80 m.



B. Ottoman

- o The Mosque of Beyazıt Paşa (A.D. 1414-1419)

$F_d + SW_{dr} + S_q + P_d + B_d + R_t$ x: 7.00 m. y: 7.15 m.

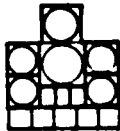

2.2 Examples of use of the nomenclature

ŞEYH NECMETTİN HAVAI BABA MAUSOLEUM
 AHLAT, BİTLİS

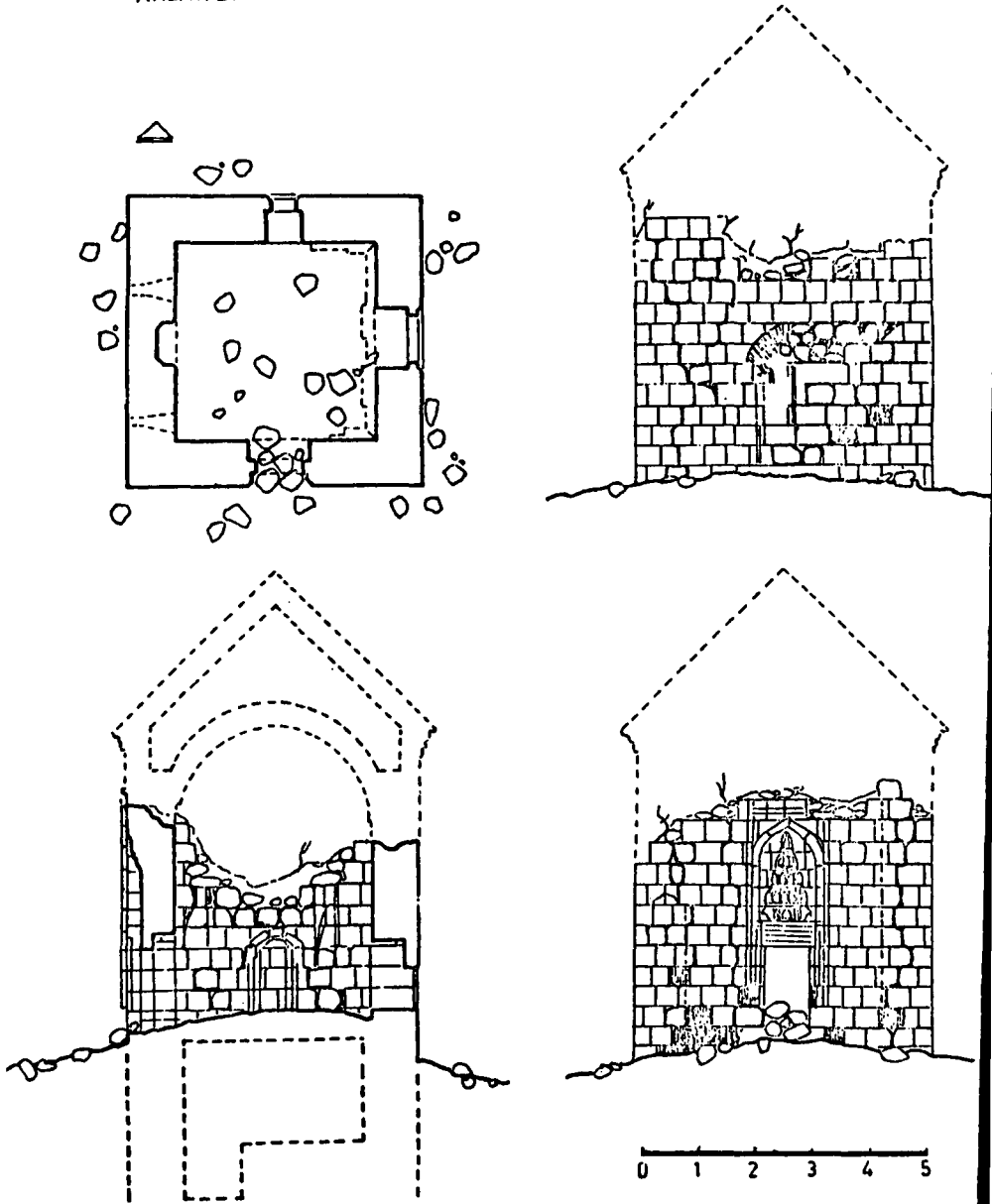

2.3 Measured survey of a Seljuk tomb

Past testing and other research have provided considerable data and a range of analytical tools - sufficient to serve as a basis for the recommendations and other guidance in chapters 4 and 5 and for most of the structural analyses referred to in the case studies. But by far the greatest effort hitherto has been directed towards the problems presented by modern structures and modern materials and construction methods. To support some of the interventions described, it was therefore necessary to undertake extensive further ad hoc studies. It will clearly be useful if, where similar testing and research are shown to be desirable by the inventories and surveys of structures at risk, this testing and research could be undertaken in a planned and systematic manner now. As with all research, it will of course be necessary to identify typical problems, since it will not be feasible to devote large efforts to the special problems that may be presented by individual structures.

The desirable studies are likely to fall into the following broad categories:

- strength tests on materials and structural elements.
- chemical and other tests necessary to assess the characteristics of the materials used in the past and the long-term compatibility of materials that might be used for repair and strengthening.
- measurements of dynamic responses to assist in estimating periods of vibration and damping characteristics.
- the development of more realistic methods of analysis.

2.2.4 Preventive structural interventions

All interventions result in some change and thus in some loss of authentic historical character. Preventive strengthening in advance of a possible future earthquake is not, therefore, recommended unless there are clear signs of weaknesses due to settlements, other changes in foundation conditions, or significant deterioration of the above-ground fabric.

Where, on the other hand, such weaknesses do exist, or where there are other reasons for immediate intervention, the risk of a future earthquake should be fully taken into account in deciding what is to be done, following the principles described elsewhere in this manual.

An example is given in the case study of the Erechtheion.

2.2.5 Preparedness for action in the immediate aftermath of an earthquake

In the confusion that is likely to follow in the immediate aftermath of an earthquake, the first priorities must be rescue of those trapped in the wreckage, care for the injured and homeless, control of fires, demolition of dangerous structures, prevention of disease, and the maintenance or re-establishment of public order. While attention is given to these, there is a real risk of wanton or unnecessary further damage to cultural property.

To minimise this risk and to be prepared to undertake the further tasks referred to in sections 2.3.1 and 2.3.2, prior planning is essential:

- there should be clearly established procedures for initial inspections and assessments of all structures included in the national inventory, for their marking and mapping to indicate their condition and how they are to be treated, and for any necessary temporary protection of either

structure or contents.

- there should be clearly defined and recognised responsibilities for putting these procedures into effect, as part of the general contingency planning for dealing with earthquakes and similar emergencies.
- there should, if possible, be suitably located stores of necessary equipment. Where it is not possible to maintain stores solely for emergency use, it would be helpful to maintain registers of equipment that could be requisitioned at short notice.

2.3 Actions after an earthquake

After an earthquake there will obviously be a need to reassess the structural condition of all monuments and other buildings identified in the inventory as worthy of preservation that are still standing. Some will require immediate emergency measures to limit further damage until permanent repair and strengthening are possible. More detailed assessments and the preparation and execution of schemes for permanent repair and strengthening will follow.

These actions are outlined in the following sections. Detailed guidance is given in chapters 4 and 5.

2.3.1 Initial inspections and assessments

As soon as possible after the earthquake, a first quick assessment should be made to indicate which structures should be protected until a fuller assessment is possible, and which can continue in use. This assessment will have to be made on the basis of a rapid visual inspection, perhaps only from outside, and a familiarity with the strengths and potential weaknesses of each type of structure. It therefore calls for a different expertise from that of the average engineer familiar only with modern structures. The value of each structure should also be taken into account, since one of high historical, aesthetic, symbolic, social, or 'documentary' value will justify a greater effort to safeguard and subsequently repair and strengthen it; similarly one whose contents are of high value. If a good inventory has been prepared and is available, this will help in establishing relative values. If not (and perhaps in any case), architectural, archaeological, or historical expertise will also be called for.

After this first assessment, each structure that is to be saved from immediate demolition should be conspicuously marked and similarly identified on a large-scale plan to indicate in which of the following categories it falls:

- undamaged or only slightly damaged and still usable (green marking).
- damaged, but not severely. Repair, and possibly strengthening, necessary, also temporary shoring or other protection, but restricted access possible for this purpose and for removal of contents that would otherwise be at risk (yellow marking).
- severely damaged, unsafe to enter, and possibly liable to partial or more extensive collapse. Decision on whether, and to what extent, repair and strengthening are feasible and justifiable calls for further inspection. In the meantime, no access allowable and barriers to prevent access required (red marking).

When the first assessment is completed, more detailed inspections should be undertaken to give a clearer picture of the extent and nature of the damage and of its significance. In general, structures in the second and third categories above should receive attention first, giving priority to those considered to be most important, but taking into account also the ease with which inspections can be made and the profitable use of time and expertise.

As before, these inspections will be purely visual ones, and the assessments the best judgements that can be made in the circumstances. Difficulties of access will mean that they will often in the first place have to be made from a distance using binoculars and possibly cameras. A mobile access crane will be valuable for high-level inspection if one is available. But one objective should be to decide what temporary strutting or shoring is necessary, and if this can be set in place as the inspection proceeds it will permit closer access. Sometimes, bearing in mind the risk of aftershocks, partial demolition may be necessary to reduce the risk of a more extensive collapse.

During the inspection, the condition of important frescoes, mosaics, or other decorative features should be noted, together with any hazards to them or to the structure from broken water pipes, damaged roofs or roof coverings, etc.

On the basis of these inspections, it should be possible to make less tentative preliminary assessments of the feasibility of repair and strengthening, to see what further investigation is required, to estimate the likely total effort necessary and judge whether it will be worthwhile, and to decide which structures should have priority for further work.

2.3.2 Emergency works

The inspections just described should also indicate what temporary works are needed to protect the damaged structure and its contents until further work is possible.

Reference has already been made to temporary strutting and shoring and possible partial demolition. More protection of this kind will possibly be desirable for major monuments, whose final repair and strengthening may not be completed for a considerable time.

Where any hazard to frescoes, mosaics, etc, from exposure to the weather or from leaking water is noted, immediate steps should be taken to provide protection or stop the leak. Where there is a risk of their falling away from the wall or vault because of structural movements, they should either be given temporary support or, as a last resort, removed to a safe place. Other contents at risk should be moved to safe storage.

2.3.3 Detailed investigations and assessments

For most structures, more detailed investigations of the structural condition should follow to provide an adequate basis for deciding on suitable schemes for repair and strengthening.

The questions to be answered should arise from the more detailed initial inspections and from the initial ideas for repair and strengthening. They may include questions about:

- the precise form of the structure before and/or after the earthquake, especially if no earlier accurate measured survey is available

- the constituent materials and critical structural details.
- physical and/or chemical properties of these materials.
- the foundation conditions and soil properties.
- the precise nature and extent of cracks, separations, and other structural movements and their significance.
- dynamic structural characteristics.
- possible future seismic loadings.
- present strengths in relation to these loadings.
- the precise condition of features like mosaics and frescoes, and any special requirements that their presence may impose on the choice of repair and strengthening techniques.

Purely visual inspections will still have a part to play in providing answers, but many more approaches may now also be required. These may range from in situ and laboratory tests on the properties of materials and structural elements to static and dynamic analyses of structural responses. The amount of testing required will depend partly on the amount of data already available from prior investigations such as those recommended in section 2.2.3, and partly on the nature of the structure and its present condition. For groups of similar structures, it should be possible to limit the most detailed investigations to representative examples of the type.

2.3.4 Preparation and execution of schemes for repair and strengthening

The engineer should be considering possibilities for repair and strengthening from an early stage - tentatively at first and more definitively as the detailed investigations and assessments proceed.

When the investigations are sufficiently advanced, two or more fully detailed schemes should be produced, analysed, costed as accurately as possible, and presented to the collaborating architects, archaeologists, and others concerned. All necessary drawings and specifications should then be completed for the agreed scheme, paying particular attention to operations of an unusual nature or calling for special care. Provision should also be made, as necessary, for continued monitoring of crack widths, etc, and for the proper maintenance of protective coverings etc.

Ideally the scheme should then proceed satisfactorily to completion with normal day-to-day supervision. For any major operation of this kind it would, however, be wiser to regard the final scheme as a datum or framework, subject to modification in the light of experience as the work proceeds. Similarly, investigation should not cease completely with the adoption of the scheme. All fresh evidence about the structure and its condition that is brought to light should be noted, and the scheme reassessed whenever the evidence seems to call for this.

Finally, Article 16 of the Venice Charter should be borne in mind: a full record should be kept of what is done, and at least two copies of this record should be deposited in safe places.

2.4 The task of the structural engineer

It will be seen from the foregoing outline of objectives and necessary actions that the task of the structural engineer will include most or all of the following:

- identifying the essential structural character of the monument or other structure under consideration - namely how it develops its strength, how it responds to seismic excitation, and what are its likely weaknesses.
- recognising the evidence of present structural condition, both that which is readily visible and that which calls for further investigation.
- carrying out any necessary investigations or arranging for and supervising them, including investigations of ground conditions.
- making preliminary and then more definitive assessments of the structural condition and (in particular) the strength in relation to future seismic loadings.
- making complementary assessments, where necessary, of the local seismic hazard.
- deciding what temporary shoring etc is needed to safeguard a damaged structure.
- proposing schemes for final repair and strengthening.
- selecting, with other consultants, the scheme to be adopted.
- preparing the necessary documentation for the selected scheme.
- supervising it during execution, and introducing any modifications that seem desirable in the light of fresh observations.
- arranging for the works undertaken to be adequately recorded for future reference, and for the safe deposit of copies of the record.

In addition to the qualities called for in normal design practice, this task calls for sensitivity to the special values of historical and cultural monuments and other structures considered worthy of preservation, an interest in and ability to appreciate the differences between their structural characteristics and those of most modern buildings, a readiness (and the necessary imagination) to work with these characteristics in devising schemes for repair and strengthening rather than ignoring them and designing as if for a new structure, and an ability to share expertise with conservation architects, archaeologists, and historians.

In sum, it is a demanding task that calls for considerable flexibility of mind and for continuing collaboration with others in defining objectives, seeking, interpreting and assessing evidence, and choosing schemes to be put into effect.

3. TYPICAL STRUCTURAL FORMS AND THEIR SEISMIC BEHAVIOUR

A correct assessment of the condition of a structure (whether before or after an earthquake), a correct modelling of it for purposes of analysis, and an appropriately sensitive choice of a scheme for repairing and strengthening it, all depend on a good appreciation of its characteristics and of the behaviour to be expected of it.

It is therefore of great importance to understand how the structures that are considered here differ from the moment-resisting frames and shear-wall structures built today, and how their behaviour differs correspondingly.

This chapter reviews the principal structural forms found in the Balkan region, looking first at the materials used and the loading, then at the principal elements, and finally at complete structural systems.

3.1 Materials and loading

The materials available in 1800 are compared, in Figure 3.1, with those available at two recent dates. The bands of strengths and stiffnesses indicate basic values. Effective strengths-in-use in 1800 and earlier were usually much lower, particularly in most masonry and - on account of the difficulty of making efficient end joints - in timber tie members. And these effective strengths may now be further reduced by weathering or other deterioration.

It should also be noted that availability is shown without restriction to the Balkans, and that in 1800 cast iron was new and was little used outside England and Russia. Thus, up to well into the 19th century, the only materials in use in the Balkans that were able to sustain much tension were timber and the small quantities of forged iron used for cramps and ties.

The chief distinguishing characteristic of the structures considered here is, therefore, that - with the partial exception of some timber frames - they carry their loads predominantly in compression. Also they are typically more massive than their modern counterparts because of the high weight-to-strength ratios of the materials. Under normal conditions, the predominant loading is, for this reason, self weight; and it is this downward gravitational load that they are best proportioned to resist. Frequently they do so in spite of fairly extensive cracking under the tensile stresses that do arise, even under the predominantly compressive loading of the structural elements.

Earthquakes affect such structures in two ways at the same time. Firstly there are the horizontal loads due to horizontal ground accelerations. These act, as on modern structures, to produce horizontal shearing actions, and may also cause overturning of parts of the structure. Secondly there are the vertical loads due to the vertical ground accelerations. These alternately increase and reduce the normal gravitational loads, and, in structures with poor tensile continuity, they can be more damaging than in modern structures. They may, for instance, allow the bed joints of masonry elements to open, leading to rocking and sideways displacements which then make overturning more likely. These effects are considered further in the following sections.

3.2 Columns

Masonry columns may be either monolithic - that is cut from a single block of stone as seen in Figure 3.2 - or built up from superimposed drums as seen

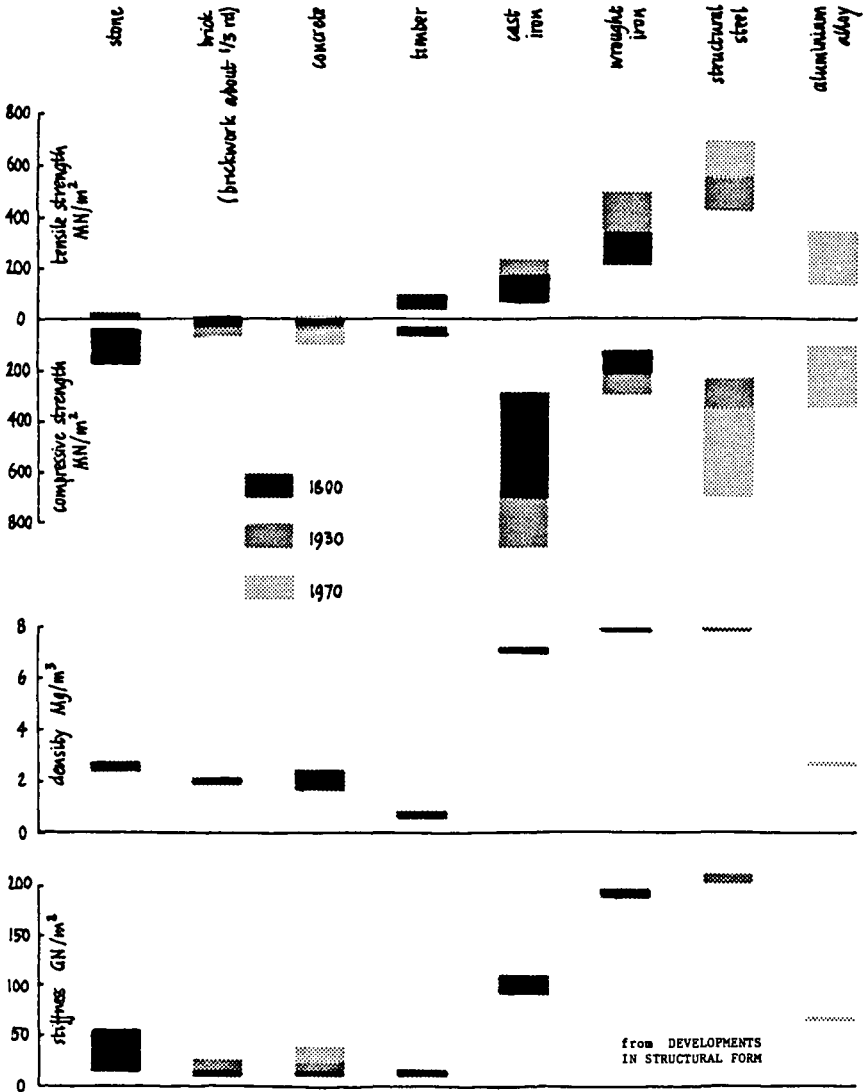

3.1 Structural properties of the available materials



3.2 Temple of Apollo, Corinth

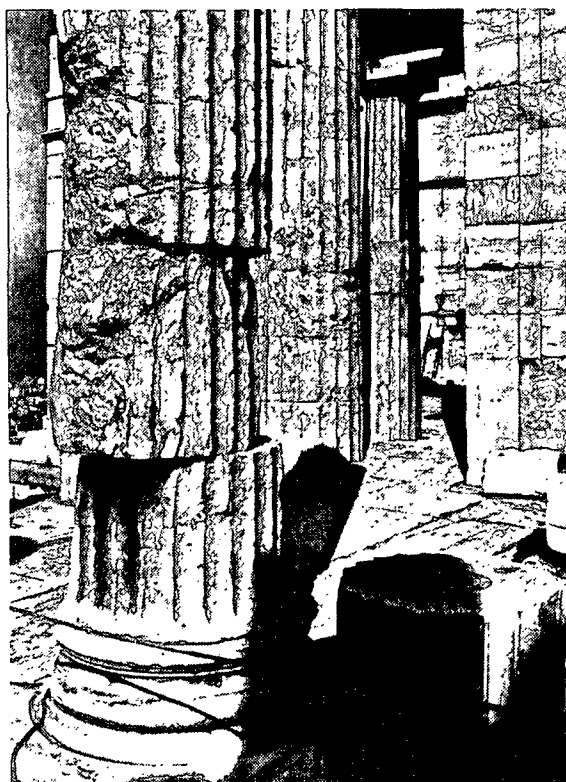

3.3 Columns of the north wing of the Propylaea, Athens

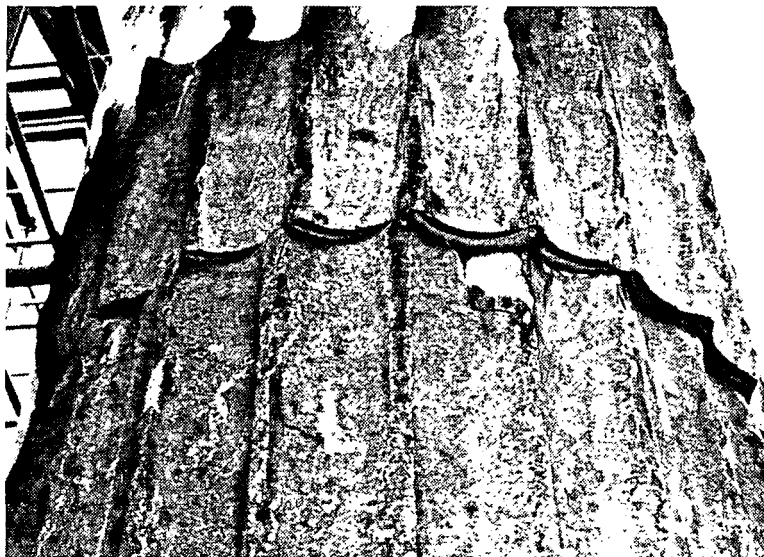

3.4 Detail of a column of the east porch, Erechtheion, Athens



3.5 Fallen columns, Temple of Zeus, Olympia

in Figure 3.3. Monolithic columns were used not only in early classical temples. They are also frequently found on a smaller scale in later buildings of other kinds, usually supporting arcades. The column of superimposed drums was used almost exclusively in the classical temple, presumably to simplify the cutting and transport of the stone. To give stability, the bearing surfaces of the drums were accurately dressed around the whole circumference and in the centre and slightly recessed elsewhere, as seen at the lower right of Figure 3.3. The drums were then set one on another without any intervening bed of mortar, though dowels were inserted to give some resistance to sliding in addition to that given by friction. In practice the frictional resistance would have been the main one, and should have prevented sliding even under earthquake loading.

Because of the large restraints to sliding, the characteristic response of both types of column to an earthquake is a rocking motion - of the whole column on its base and of individual drums on those below. During rocking however, twisting also occurs due to the continuing horizontal and vertical accelerations of the ground, and this may result in horizontal displacements that look like slips. Figure 3.3 shows gross displacements of this kind of the drums of the column on the left, though these may not be due solely to past earthquakes. Figure 3.4 shows much clearer evidence of a further displacement of the upper drum by the earthquake of February 1981. The fresh displacement is indicated by the lighter colour of the newly exposed under surface of the upper drum, and one point about which rocking occurred by the spalling off of a piece of the edge of the lower drum. Note, however, that the spalling damage is very slight. Displacement of the drum has a more significant effect on the margin of safety against overturning.

Collapse, if it occurs, will be by overturning. As in all cases of dynamic structural response, the likelihood of this depends on the natural frequency of response in relation to the frequencies of the imposed motion. Here, since the relevant response is a rocking motion, the natural frequency will reduce markedly as the amplitude increases and overturning becomes more likely, and this reduction will usually take it outside the range of the predominant ground frequencies. Tall slender columns are also less at risk than would be expected for a static response, on account of their low natural frequencies. It now seems likely, in fact, that many of the collapses that have occurred are not due solely to earthquakes, but have been caused partly by prior human interference - which often took the form of cutting into the base to extract the metal used in the dowels. A risk of collapse in a future earthquake will arise chiefly where stability has already been reduced either by damage of this kind or by other local damage or by extensive relative displacements of drums.

3.3 Walls and piers

Walls and piers were invariably built from smaller units, but in many different ways. Slenderness also ranged widely. Broadly speaking, slender walls are most likely to fail by overturning when subjected to transverse shaking, rather like slender columns of superimposed drums. Thicker walls subjected to similar shaking are more likely to fail by primary internal disruption, the risk of this being greatly dependent on the manner of construction. When the shaking is in the plane of the wall, both may fail in shear, by diagonal cracking.

3.3.1 Walls of unmortared unshaped blocks

This is probably the oldest type of masonry construction. It is difficult



3.6 Walls of un-mortared stone rubble with bonding timbers



3.7 Fortress wall of large roughly dressed un-mortared blocks, Tiryns

to achieve stability, even under purely self-weight loading, if the blocks are very irregular in shape and small in relation to the height of the wall. It has then usually been done partly by packing the gaps between the larger blocks with smaller stones and partly by introducing lengths of bonding timber at intervals. A wall constructed in this way in a rural dwelling in Anatolia is illustrated in Figure 3.6. It is shown after an earthquake. This has led to the complete disintegration and collapse of the upper part, but the lower part has been held together by the bonding timbers.

Surviving structures of individual historical importance were constructed from much larger blocks, which made it easier to achieve stability. In the example illustrated in Figure 3.7, the blocks have been selected with great care or partly shaped. Flat through stones have also been introduced at intervals to bond the construction together through its thickness. The imperfect bearing of the blocks on one another has, however, resulted in bending actions on the through blocks and in excessively high local compressions, which have produced some fractures. Nevertheless, the structure probably still has a large margin of safety after more than three thousand years, on account of its proportions.

3.3.2 Walls and piers constructed throughout their thickness of unmortared fully shaped blocks

Shaping of the blocks so that they fitted closely without any packing greatly improved stability and reduced stress concentrations and unwanted bending actions, thereby making it possible to adopt much more slender proportions. Walls and piers of well squared masonry were constructed in the region from early classical times after tentative beginnings a thousand years earlier. Examples from Turkey and Greece are shown in Figures 3.8 to 3.11, the last being a counterpart to the construction shown in Figure 3.7 with through stones laid flat for bonding purposes.

With good uniform bearing between courses and proper breaking of vertical joints, friction at the joints and the tensile strengths of the individual blocks should have been sufficient to prevent both horizontal sliding and opening of the vertical joints under the action of in-plane seismic loads on a single length of wall. Considerably larger loads could act, however, if there was a bonded return wall repeatedly pulling away at the end, and if the presence of an opening in the wall concentrated this pull on a few courses. Figure 3.12a shows an example of this situation and the resultant separations.

Presumably with the intention of preventing such separations, adjacent blocks were often cramped together as shown in Figure 3.13a, the cramps here being of iron set in lead for protection against corrosion and to achieve a close fit. The blocks of the wall seen in Figure 3.12b were cramped together in this way. The cramps have not wholly prevented separations, but they may have done so in earlier times and they have concentrated the separation and slip on one line. If corrosion does occur, such cramps do far more harm than good because the resultant swelling of the iron splits the stone in which it is set as seen in Figure 3.13b.

3.3.3 Walls with facings of unmortared shaped blocks and a loose fill

Walls of this type are mostly defence walls or retaining walls. Those that remain have done so by virtue of their proportions and the sound construction of the facings. Figure 3.14 shows a wall preserved for its full thickness. Figure 3.15 shows one facing only remaining, both witnessing to the soundness

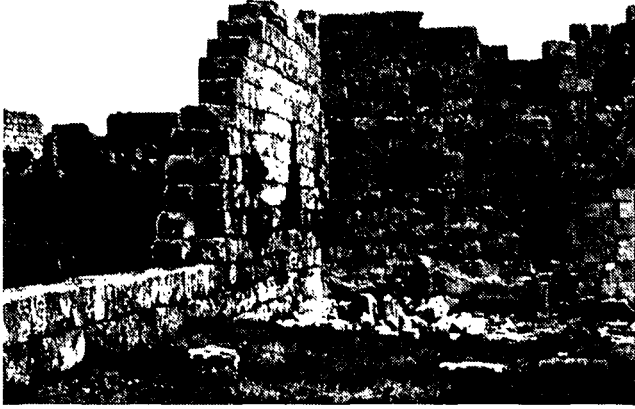

3.8 Later southern city wall, Perge

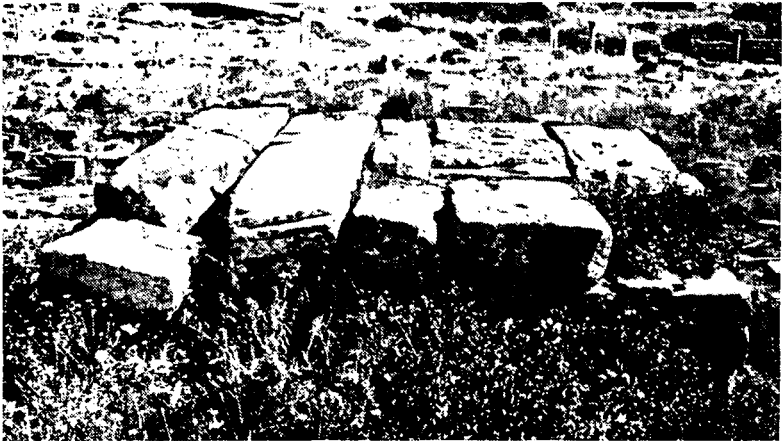

3.9 Base of a pier, Roman Agora, Ephesus

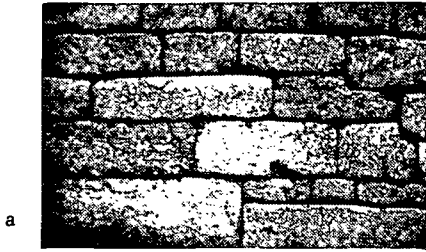

3.10 Random coursed and isodomic masonry, Mycenae and Athens



3.11 Pseudisodomic masonry, Delphi and Ephesus

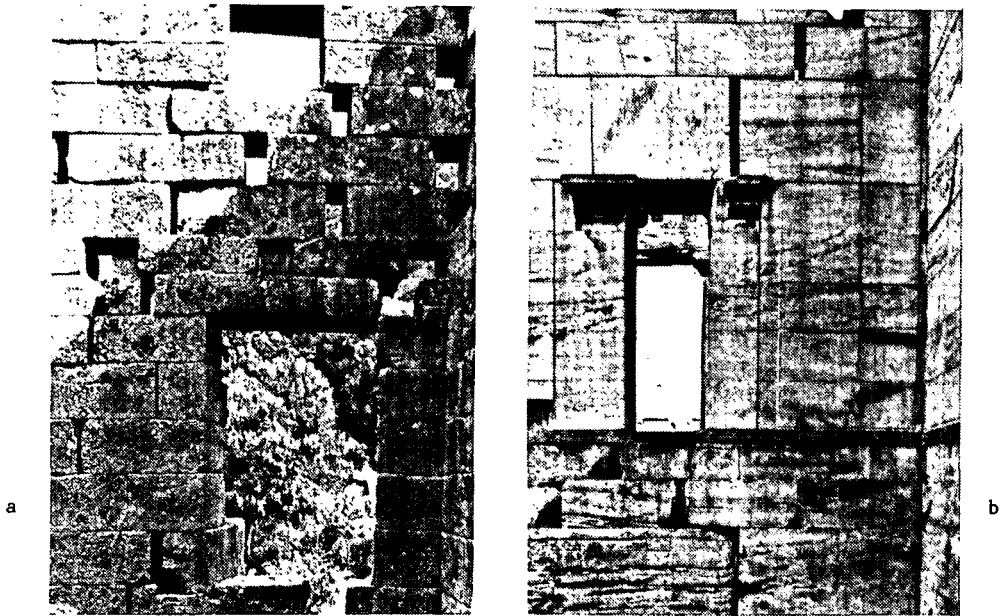

3.12 Dislocated masonry, Messene and Propylaia, Athens

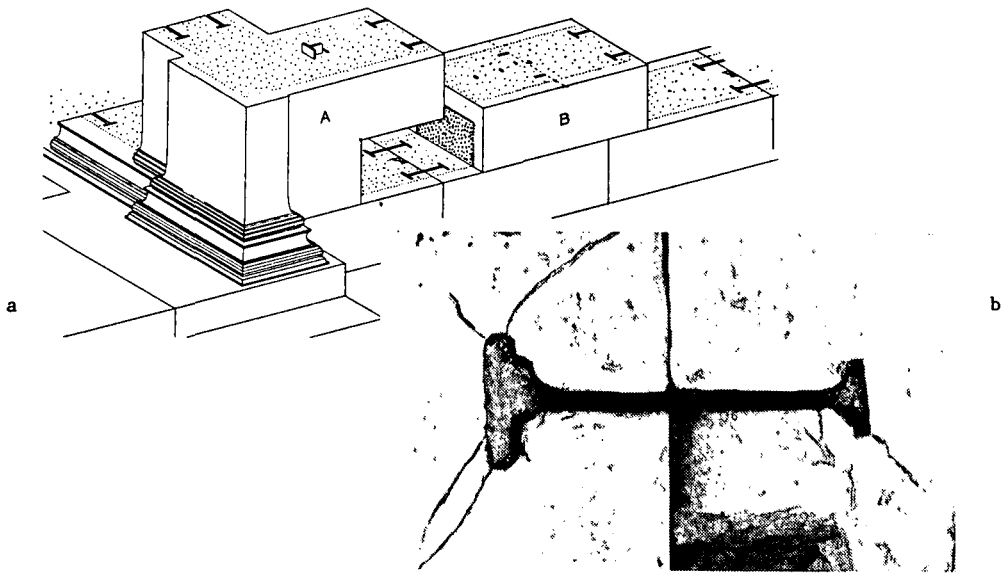

3.13 Iron cramps in the Erechtheion and Parthenon, Athens

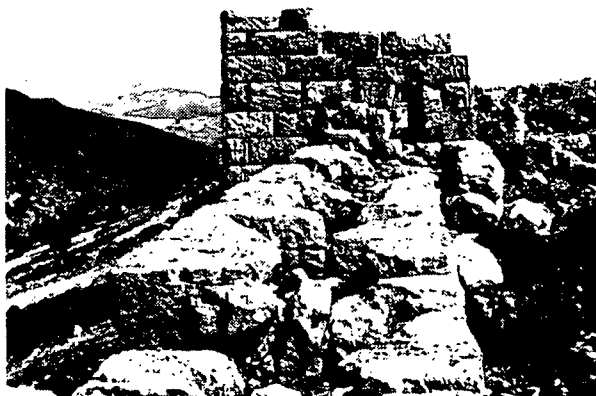

3.14 Defence wall, Eleutherai



3.15 Defence wall, Messene

of its construction and exposing the blocks that originally projected into the fill for bonding purposes.

3.3.4 Walls and piers of mortared stone and brick

Mortar serves, in the first place, to fill the gaps between units and thereby provide a uniform bearing without the need for accurate cutting or shaping. Some strength is required to transmit the stresses from unit to unit. But the requisite strength depends on the degree of confinement of the mortar as well as on the average stress in the wall or pier. Bond strength at the interfaces is also required if there is any tension to be transmitted. Many mortars have been used in the past, ranging from the mud used to build walls from unfired mud bricks to the strong pozzolanic mortars used to make Roman concrete and similar later hydraulic mortars that incorporated pulverised underfired brick in place of a natural pozzolana. The manner of use has also varied widely. A few examples only can be given.

Figures 3.16 and 3.17 show thick walls constructed from brick in the first case and part brick and part stone in the second. The walls are partly cut through, thereby showing the uniformity of the construction right through the thickness. Strong hydraulic mortars have been used, giving the masonry a character resembling that of Roman concrete. Damage to the facing of the first is not due to earthquake. Damage to the second may have been partly caused in this way, but not wholly. What is chiefly significant about it is that there are just two clean diagonal cracks in the wall seen face-on. Walls like these may be expected to behave not very differently from their modern counterparts.

Figures 3.18 and 3.19 show walls with facings of cut stone and thin fills of mortared small rubble between the facings. The mortars appear less good than in the previous examples, but they have prevented any separation of the facings. Both walls have been badly damaged by recent earthquakes. The first shows the diagonal cracking that results from alternating horizontal loads in the plane of the wall. The second shows essentially a failure in direct tension as the wall to the right that has completely overturned pulled away.

Less satisfactory performance is to be expected where walls are of non homogeneous construction (like the last two examples) but the mortar was weaker, or has become weaker with time, the filling between the facings was composed of small rubble, and little or nothing was done to bond the facings together. There is then a considerable risk of the facings separating from the fill and from one another. Not only will they be weaker in this condition. They are likely to be weakened further by loose rubble falling between them and bowing them outwards. Figure 3.20 shows serious bowing of this kind of the outer facing of a town defence wall after an earthquake. Figure 3.21 shows a two-skin wall in a house in the same town after the same earthquake. Here the skins have separated but no serious bowing has yet occurred. A wise practice in some areas where walls were constructed of stone rubble throughout the thickness was to build-in timber bonding courses at regular intervals, as seen in Figure 3.22. Straight timbers on each face are connected, as in a ladder, by frequent short cross timbers (whose ends may be seen projecting slightly just above some of the long timbers). This produces a wall of much improved seismic resistance while the timber remains in good condition.

3.3.5 Timber-framed walls

For small structures such as houses, a complete braced frame of timber has,



3.16 Temple of Serapis, Pergamon



3.17 Defence tower, Istanbul

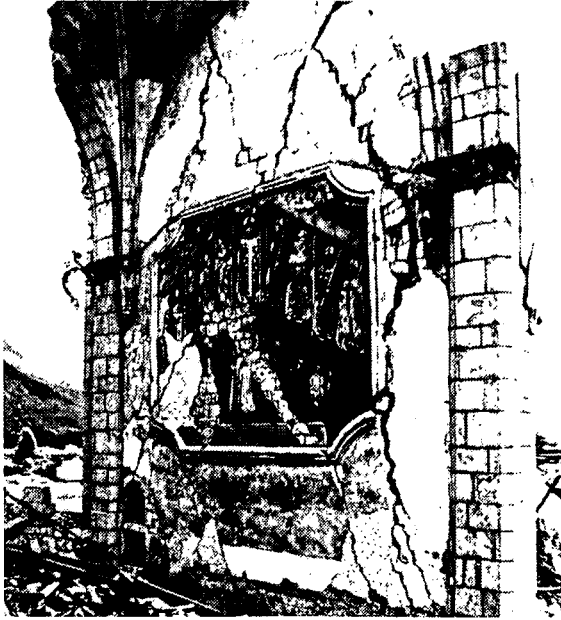

3.18 Cathedral, Venzona



3.19 Uspenje Chapel, Gradiste Monastery



3.20 Defence wall, Budva



3.21 House, Budva

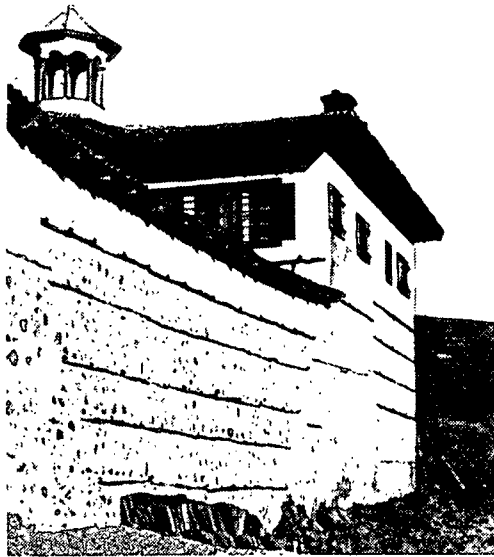

3.22 Rozhen Monastery

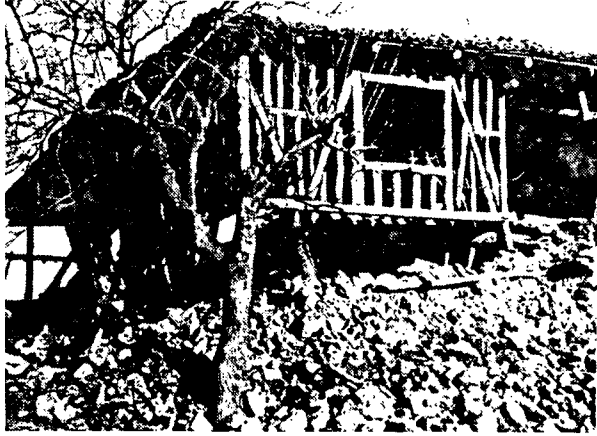

3.23 House, Gediz



3.24 Kirazlimescit Sokagi, Istanbul



3.25 House, Skopje



3.26 House, Turkey

in the past, probably provided the best assurance of structural survival in an earthquake - though it did so at the expense of an increased risk of destruction by an ensuing fire. This has been repeatedly demonstrated as seen, for instance, in Figure 3.23. The frame has the strength to resist in-plane horizontal loads, and energy absorption capacity is provided by slight play in the joints. A cladding of timber boards, as in Figure 3.24, improves the performance. But good performance may still be obtained when the frame is filled with masonry, though this is heavier. It will crack and any rendering will show the cracks. But, as Figures 3.25 and 3.26 show, the frame will prevent complete disintegration.

3.3.6 Defence walls and retaining walls

In terms of construction type, defence walls and retaining walls belong to one or other of the categories already described. They are always stiff as well as massive, and will experience directly the peak ground accelerations in an earthquake without any dynamic amplification. From this point of view, they should suffer little damage except, perhaps, to parapets and similar features. Damage is more likely to result from weaknesses of construction already referred to, from weaknesses introduced by earlier human intervention, and from foundation problems. The latter are discussed further below. Other aspects are discussed further in the case study.

3.4 Foundations

Much less is known about the foundations constructed in the past. For some important structures, they were constructed with great care, as is evident from Figure 3.27. Far more frequently they were probably no better than shallow footings. Evidence of differential settlements will frequently be seen in large structures that were not founded directly on rock. But these will have stabilised long ago unless there has been some recent significant change in the ground conditions, and any consequent weakening of the structure should be clearly visible above ground.

Earthquake damage directly attributable to movements at foundation level is likely chiefly where the ground itself is weak and deforms as in the case of the slip seen in Figure 3.28, or where the structure slips bodily on a sloping base as seen in Figure 3.29a and b.

3.5 Beams and lintels

The timber beam and the stone lintel have long been used for spanning gaps (Figure 3.30) and constructing floors and roofs (Figure 3.31). If they remain unbroken, they exert no side thrusts in supporting vertical loads, though they may, through friction at the ends or through some anchorage, serve as horizontal interconnections of their supports.

Flexural failure of heavy stone lintels is not, however, uncommon, as seen in Figures 3.32 and 3.33, and it may occur as a result of the increased vertical loads due to the vertical ground accelerations in an earthquake. Once it has occurred, the lintel will thrust outwards like an arch.

3.6 Trusses

Trusses are found chiefly in roofs. They should behave as beams, but if the connections between the principal tie and the rafters are damaged and no longer effective, the coupled rafters will thrust outwards as arches.



3.27 Temple of Apollo, Delphi



3.28 Transfiguration Monastery, Tarnovo

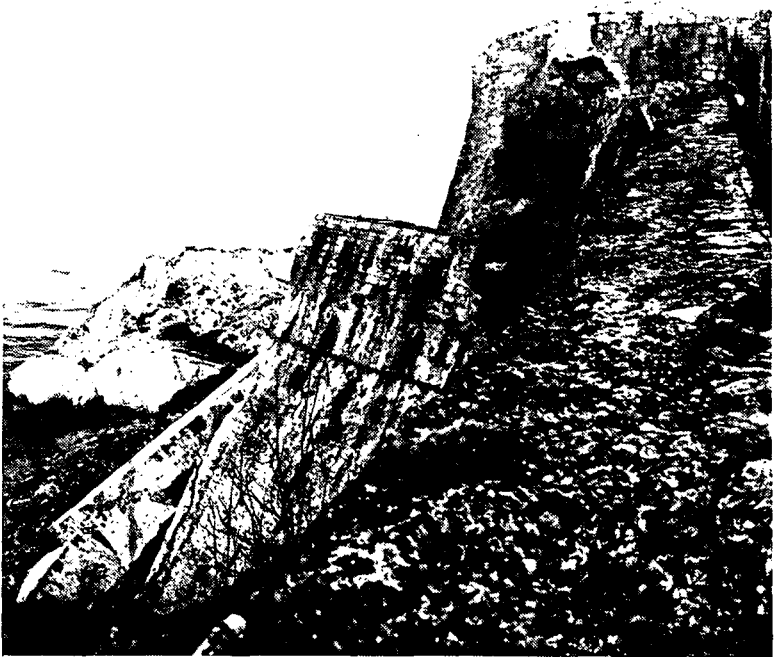
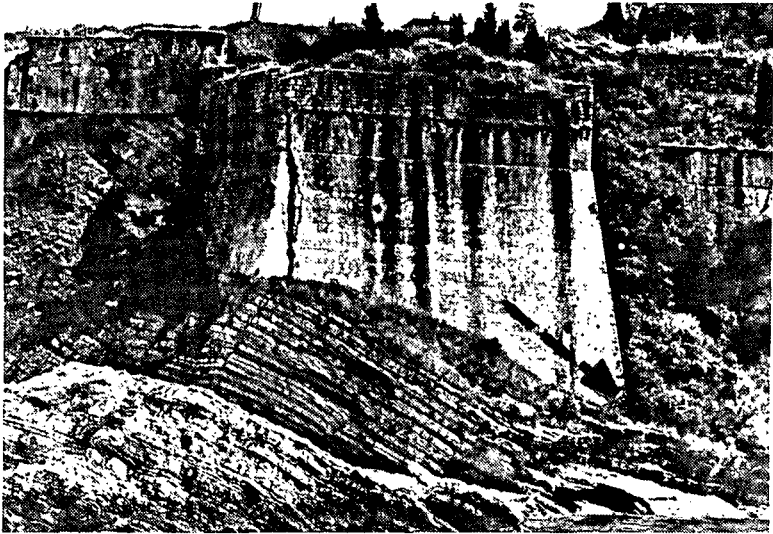

3.29 Rampart of the Castle, Corfu, before and after collapse



3.30 Lion Gate, Mycenae

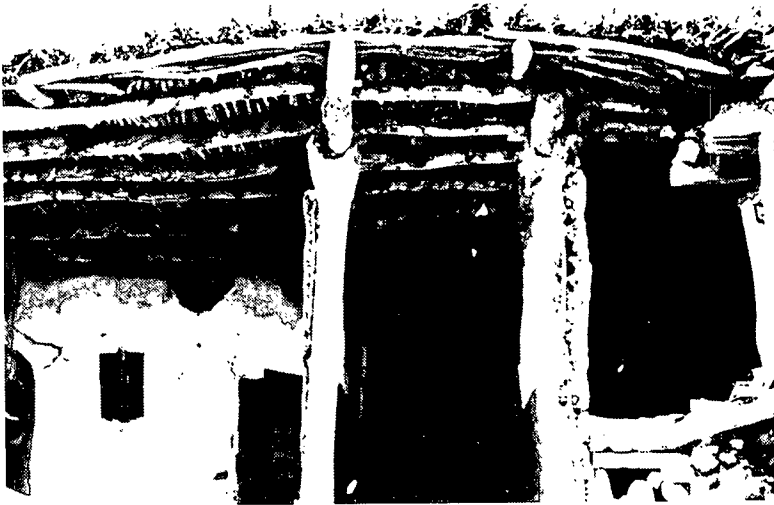

3.31 Rural house, Turkey

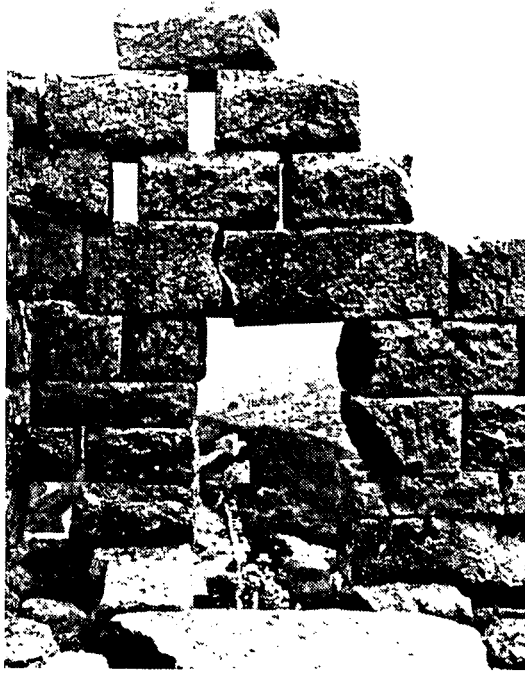

3.32 Detail of a defence tower, Messene



3.33 Broken architrave, Olympieion, Athens



3.34 Stone voussoir arch, Ephesus



3.35 Brick arch, Ephesus

3.7 Arches

Arches of brick or stone were one of the usual spanning elements in the past, and they were used almost invariably from Roman times onwards where large loads had to be carried. The semicircular profile was commonest, but far from universal. Profile is not of great importance structurally, however, if the depth of the arch ring is adequate to contain a sufficient range of possible thrust lines. It is of still less importance if there is a stiff spandrel above the arch, because this will favourably modify the distribution of loads reaching the arch.

Semicircular arches of brick and stone are shown in Figures 3.34 and 3.35. They are from partly ruined structures, but their abutments have stood firm and they are not noticeably deformed. An arch can collapse only by first undergoing considerable deformation, and the manner of deformation is therefore important. If there is no spandrel above the arch and there are no limits in stresses within it, collapse can occur only when a situation like that shown in the upper sketch below arises, and movements of the supports arising independently of the arch can be accommodated as shown in the lower sketches.

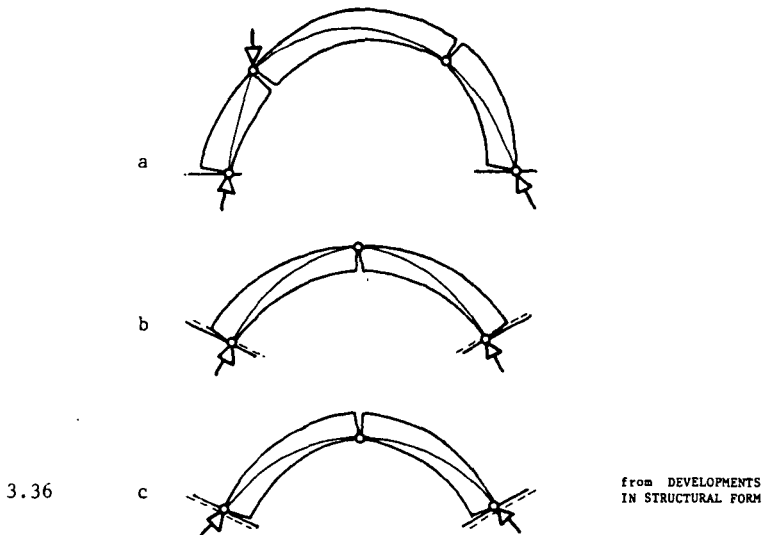

In practice, stresses cannot be ignored. The simple hinging rotations about axes on the extrados or intrados would entail impossibly high stresses and, even before the thrust lines moved out this far, there would be local splitting or crushing. This is illustrated by the sequence of photographs reproduced in Figure 3.37, though these show three different arches and the two lower ones are stiffened by the spandrels. The local splitting leads to slipping and this can lead in turn to the fall of part of the arch as seen in the bottom photograph. Figure 3.38 shows both hinging rotations and slips in a multi-tiered arcade, associated with outward inclinations of the piers towards the end of the arcade (which is at the left hand side). Slips can also occur when the supports move apart independently of the arch thrusts as seen in Figure 3.39, or when they similarly undergo a parallel relative movement as may happen to paired buttresses interconnected by arches.

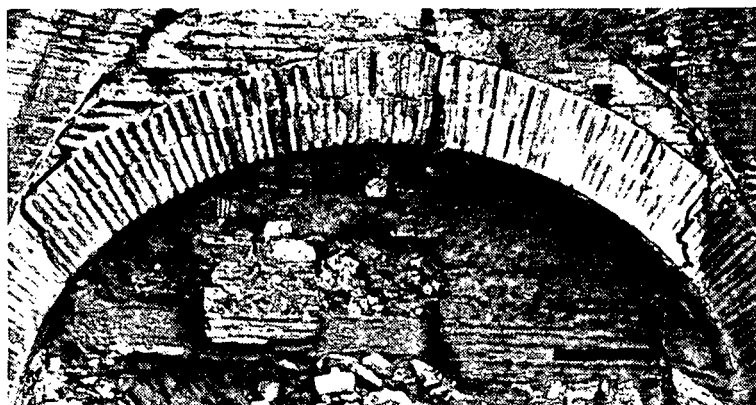

3.37 Arch deformations

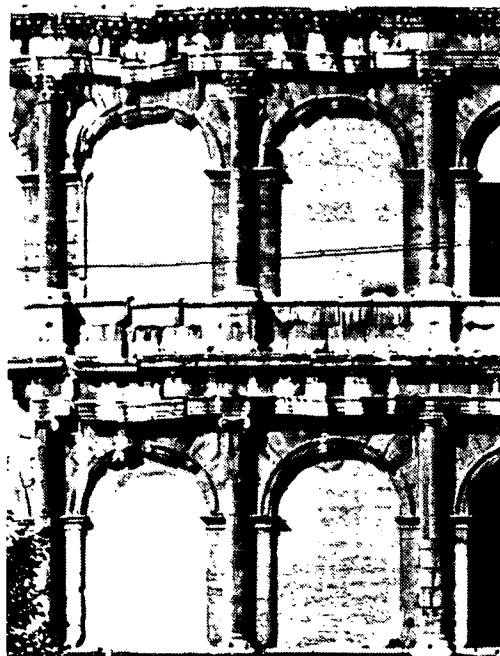

3.38 Flavian Amphitheatre (Colosseum), Rome



3.39 Governor's Palace, Kotor

Earthquakes may affect arches both directly and indirectly. The chief direct effect will be that of the vertical ground accelerations which, although they are usually smaller and less damaging than the horizontal ones, may here be of some importance in alternately increasing and reducing the vertical loading and, in consequence, the thrusts. The indirect effect will arise through movements of the supports caused by the horizontal accelerations.

The response of the arch to movements of the supports must also be considered. If the arch accommodates a spreading of the supports by hinging rotations as shown in the middle sketch of Figure 3.36, it may be able to return to its previous condition when the loading on the supports allows them to do so. If, on the other hand, it accommodates the spreading by a slipping downwards of the keystone, as shown in Figure 3.39, or by similar slipping of a larger wedge-shaped piece of the crown, there will be no possibility of a return to previous condition. Then, in successive cycles of loading, the supports will be permanently wedged further and further apart. An arch without an effective tie across its springs can thus be an agent of destruction.

3.8 Vaults

There is no sharp distinction between the arch and the barrel vault, which is simply an arch extended in the direction of its axis. As an economy, the depth was sometimes reduced and the vault stiffened at intervals by deeper ribs. But the differences in behaviour are not of sufficient importance to call for further comment here.

The groined vault is formed by intersecting barrels. Sometimes there are ribs along the groins with thinner masonry between them, and sometimes the barrels forming the vault are arched upwards towards its centre to give a domed form in this region. In general, the loads will be transmitted down to the groins along similar paths to those that they would have followed in the constituent barrels as sketched below, and will then pass down the arched ribs or groins.

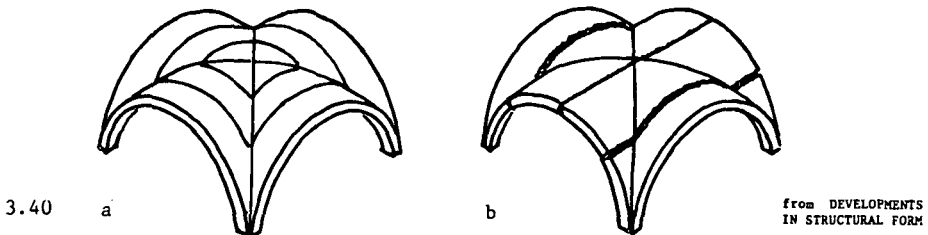

Behaviour will, in general, be as would be expected of the constituent barrels and arches, except that, if the supports spread in relation to one barrel for instance, the other will have to split open slightly to accommodate the spread and the deformations of the first barrel. This is sketched in an idealised manner to the right of the Figure above.

3.9 Domes, semidomes, pendentives, and squinches

The dome is, in form, an arch rotated about a vertical axis through its crown. But its three-dimensional surface geometry permits, in principle, the three-dimensional manner of supporting the loads acting on it that is exploited in

modern shells. In particular, the outward thrusts of the radial arches can be wholly contained in a hemispherical dome by circumferential tensions in the lower part as sketched at the left below, provided that there is the necessary capacity to resist this tension and there are no horizontal restraints at the base. In fact, these conditions were probably never fulfilled. The masonry could not itself resist much tension and it was frequently interrupted by a ring of windows, or set on a drum similarly interrupted. It therefore cracked radially as sketched at the right and shown in Figure 3.43, thereby making the dome act essentially as a ring of arches with a common keystone.

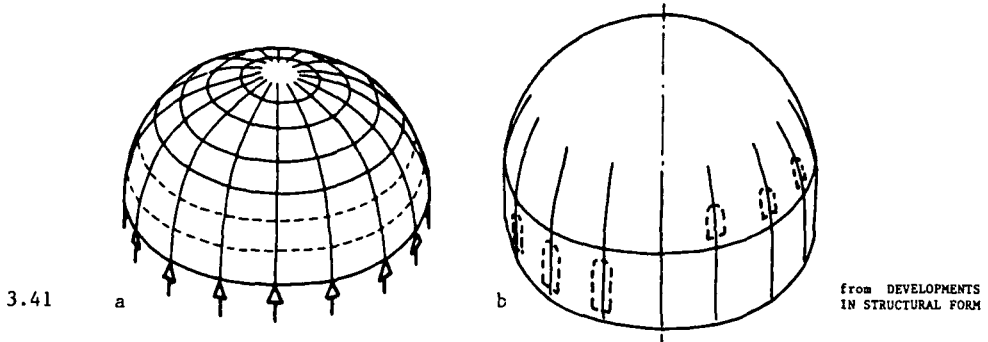

Some domes were set directly on a circular base. But many were carried on isolated piers (usually four but sometimes more), or the drums were carried in this way. This created a need for transitional elements between the polygon of arches that spanned between the piers and the dome or drum. There were two basic elements - the pendentive and the squinch. The first is sketched below and is also shown in Figure 3.44. It acts essentially as a downward continuation of the dome, thrusting outwards but carrying the thrust lower down. The cracks that develop when the supporting piers move apart involves dome, pendentives, and arches, as seen in Figure 3.44.

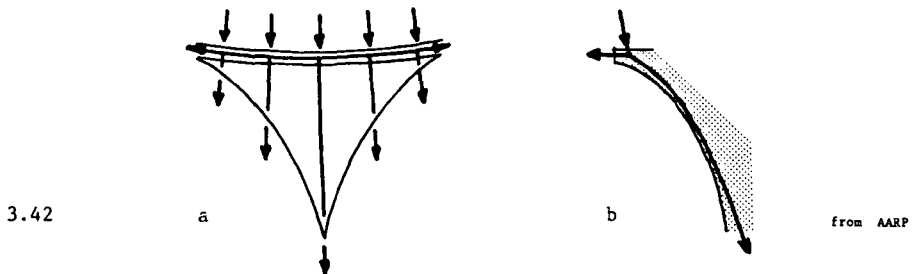

The squinch has more the character of another supporting arch, transforming a square base to an octagonal one, for instance. If the masonry were thin in relation to its surface dimensions, the loads would be carried as sketched in Figure 3.47. Usually it is filled out at the back to a pendentive-like form, so that the behaviour is closer to that of the pendentive. The simple squinch must, in any case, be capped by smaller squinches or pendentives to complete the transition to the circle, which further blurs the distinction between the two forms.



3.43 Baths of Trajan, Rome



3.44 Western dome and pendentives, Hagia Irene, Istanbul

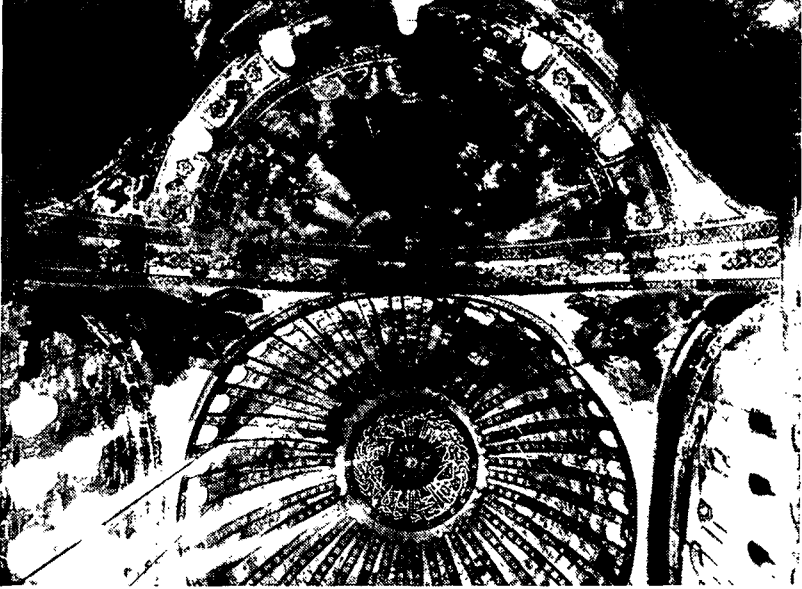

3.45 Vertical view of the eastern semidome and dome, Hagia Sophia Istanbul

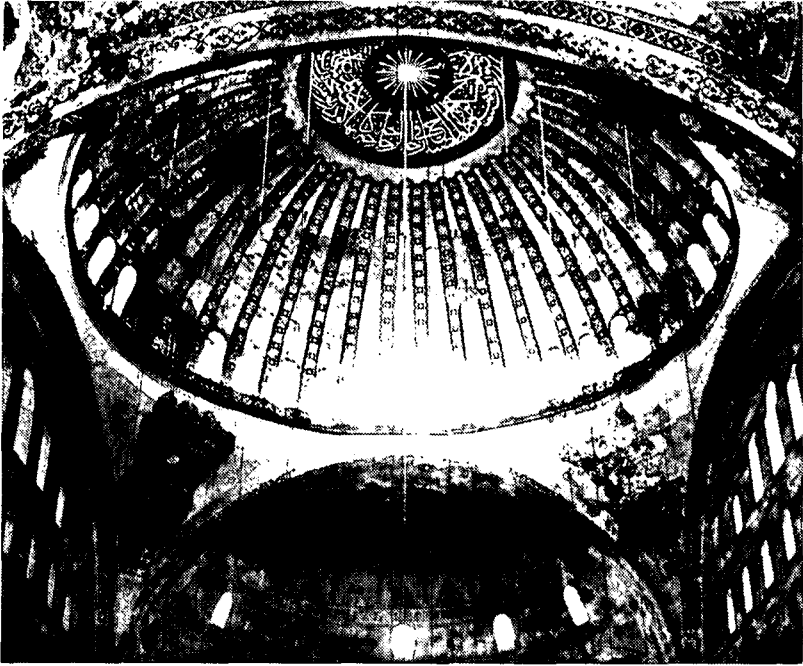

3.46 Oblique view of the dome looking westwards, Hagia Sophia, Istanbul

3.47

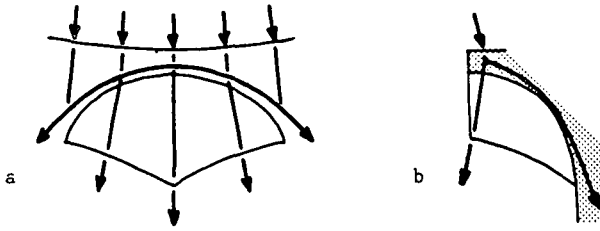

from AARP

If the dome sketched in Figure 3,41a is notionally sliced vertically in two through the crown, the resulting form is the semidome. There will be large radial forces pushing the crown outwards until these forces are balanced by the effective development of a horizontal arch behind the cut edge. All semidomes show this forward movement of the free edge in addition to the usual radial cracking of the lower part even if, as seen below and in Figures 3.45 and 3.46, a dome above later exerts opposing thrusts. These will push the free edges back as the semidomes assume the role of buttresses, but only part way because of the influence of sequence of construction when stiffnesses develop progressively as the mortar hardens.

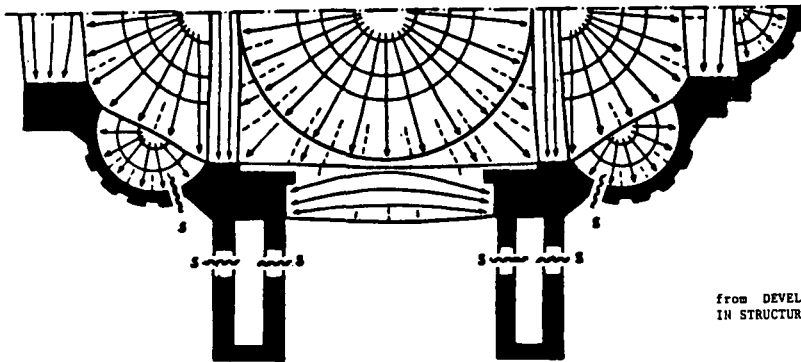
from DEVELOPMENTS
IN STRUCTURAL FORM

3.48 Half plan of the dome and semidomes of Hagia Sophia, Istanbul

To summarise, all the doubly curved forms described in this section should be regarded as three-dimensional systems of arches rather than as systems of the kind of thin shells that are built today, although modern shell theory can give some useful insights into their behaviour. Figure 3.48 above also illustrates this: the arrowed lines which represent the directions of the radial compressions can also be read as denoting the effective system of arches. (The broken lines denote cracks separating the effective arches, and the other lines lettered 's' denote shear failures in the system of supports.) The final paragraph of section 3.6 is therefore relevant to these forms also.

3.10 Ties

The disruptive tendency of the arch and of other arch-like forms has been countered by two further elements - the tie and the buttress.

Ties of both timber and iron are found. They usually span between the



3.49 Vaults and ties, south aisle, Hagia Sophia, Istanbul

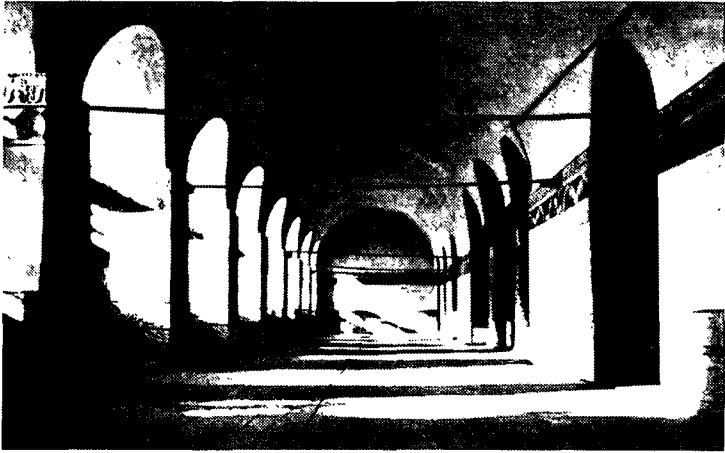

3.50 West gallery, Hagia Sophia, Istanbul

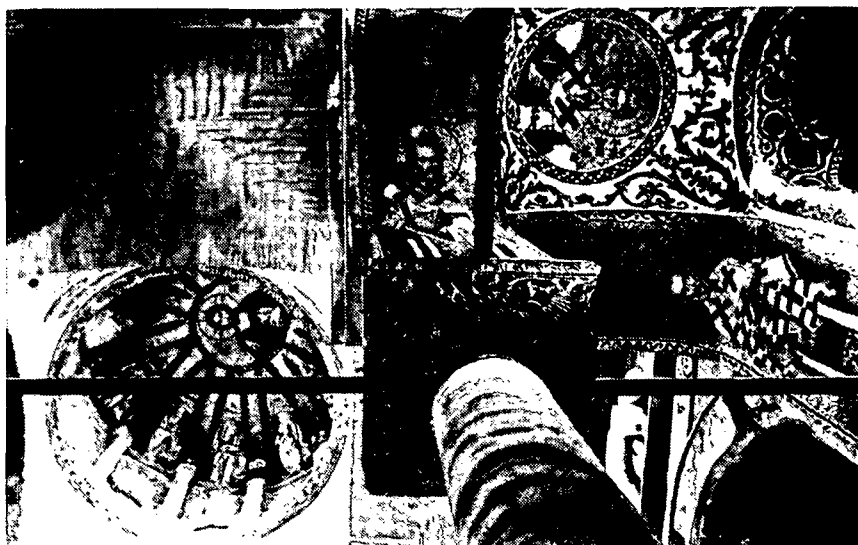

3.51 Theotokos Pammakaristos (Fethiye Camii), Istanbul

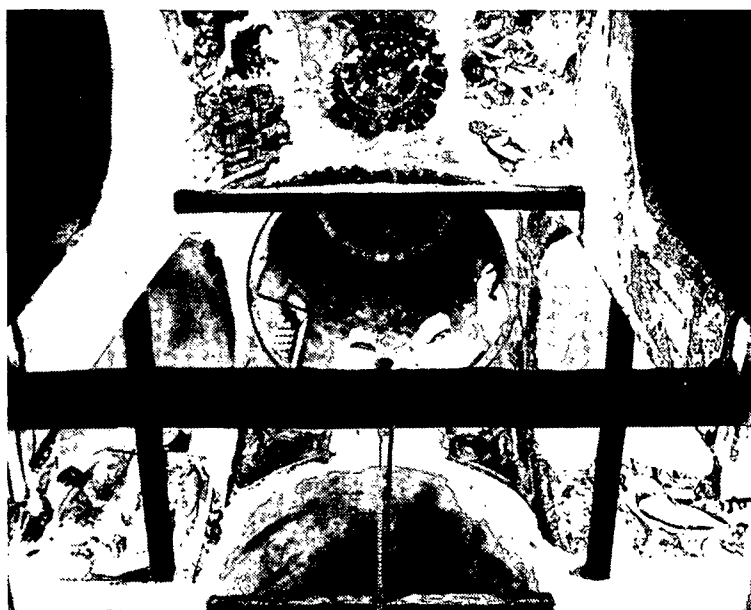

3.52 Dodekheka Apostoli, Thessaloniki

springings of arches and vaults as seen in Figures 3.49 to 3.51, but they may span between the same supports at more than one level as seen in Figure 3.52 and in the centre of Figure 3.49 (where an upper timber tie is partly hidden by the lower iron tie). In this latter case however, one 'tie' may be acting more as a strut in relation to an arch that springs at its level from the opposite side of the column. It will then be found to be of timber even when the true ties are of iron.

A second use was around the bases of domes and semidomes and, if these or the drums beneath them were interrupted by rings of window openings, across these openings. One way of constructing a tie in the former positions was to use iron cramps to bind together all adjacent blocks of stone of the cornice on which the dome or semidome was built. These blocks then had to act as links in a chain.

A further very important use was to restrain outward tilting and bowing of external walls in multistorey buildings. These ties are always of iron, and they usually run across the building within the depths of the floors as seen in Figure 3.53. It is probable that many, if not most, were incorporated only after some movement had demonstrated a need. But there is ample evidence of their value in preventing collapses in earthquakes.

Unfortunately not all ties achieved their intended purpose and remain effective today. This is partly a consequence of the inability of those who designed and installed them to determine the precise requirement, and partly the result of decay of timber, rusting of iron, and inadequacy of end anchorages. Figure 3.54 shows the end anchorages of ties installed to prevent outward movements of the two walls. They prevented a collapse that might otherwise have occurred in the 1979 Montenegro earthquake, but the walls were on the point of pulling away from the anchorages, which failed to distribute the restraining forces over sufficient areas of wall surface. Figure 3.55a shows at the centre top, a glimpse of an iron cramp inserted at the time of construction to join two adjacent blocks of the marble cornice from which the small semidome on the left of Figure 3.48 springs. It is still intact. But it was inadequately anchored in the block on the right and this split at the point of anchorage, the split being visible near the right of the photograph. The semidome then cracked over the join between the cornice blocks as seen at the top and as marked by an 's' in Figure 3.48. Sometime later, a continuous tie of long iron bars pinned together was set in a chase cut in the cornice at the foot of the semidome. This tie is seen at the bottom of Figure 3.55a and again in Figure 3.55b. But it was inadequately anchored at the end seen in the latter Figure and sprang out its chase, thereby allowing further movement on the line of the original break.

3.11 Buttresses

Buttresses restrain undesirable movements of other elements by leaning and pushing against them rather than by pulling. It is this function that identifies them rather than the form or manner of construction. The forms that have usually been adopted are those of the pier built directly against the element to be kept from moving and the free-standing pier connected to this element by one or more arches and/or walls.

Figure 3.56 shows the heavily buttressed exterior of Hagia Sophia, Istanbul. The arches and vaults of the aisles and galleries that almost completely surround the structure are buttressed by massive piers built against the lower outer walls on three sides as seen at the bottom of Figure 3.58. At this level at the west the buttresses take the 'flying' form seen in Figure 3.59.



3.53 Cross tie in the floor, Hegemoneion, Karlovasi, Samos

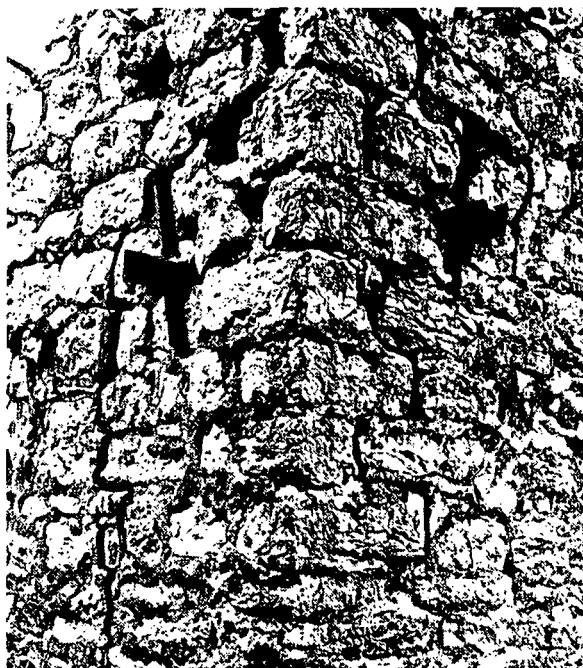

3.54 Anchorages of ties, Praskvica Monastery



a



< view a

b

3.55 Ties in the southwest exedra, Hagia Sophia, Istanbul

The piers on the left support the half arches which lean against the outer wall and against the vaults inside, the upper vault being the one shown in Figure 3.50. Finally, the high-level semidomes and dome are buttressed on the side seen in Figure 3.56 and shown in the half plan in Figure 3.48 by the prominent tower-like forms seen also in the upper part of Figure 3.58. These actually consist of outer staircase towers connected to the main piers that carry the dome by arches and barrel vaults at aisle and gallery levels and by the walls shown in plan in Figure 3.48 above the gallery.

Buttresses, like the ties found in multistorey buildings, will often be found to have been added to the structure only after movements had demonstrated a need. This may considerably reduce their value if they were called on to resist further movement before the masonry had gained its full strength and stiffness or if their resistance could be mobilised only after significant settlements and associated tilting. Figure 3.57 shows a typical elevation of the walls that link the main piers (on the left) to the staircase towers (on the right) in the high-level buttresses of Hagia Sophia. They should have ensured that the main piers and staircase towers moved as a single unit if they moved at all. But, perhaps on account of hasty construction and early subjection to earthquake loading, there were pronounced shear failures which permitted the piers and staircase towers to move more independently and to lean out much more than would otherwise have been possible.

Where buttresses are part of the original construction and stand on similar foundations, they will be more effective in that they will restrain outward movements without first giving way themselves to the same extent.

3.12 Classical temples and colonnades

In the Greek classical temple, its Hellenistic and Roman counterparts, and many surviving remains of these, the columns discussed in section 3.2 are interconnected by stone lintels in colonnades, which are themselves, in the complete structures, further connected to walls of the type discussed in section 3.3.2. The longitudinal walls are also buttressed against possible overturning by return walls, usually well bonded to them. Sometimes, in the largest temples, the colonnades stand in parallel rows, as seen in Figure 3.60.

The interconnections between the elements may be expected to affect the behaviour in an earthquake in several ways. Most obviously they will make less likely the separate overturning of single columns or lengths of wall and the overturning of a complete colonnade when this is shaken transversely to its length. On the other hand, natural frequencies will be increased where the structure is fairly complete and this may increase the loading for a given ground acceleration. And, where the structure survives only in part, it may experience overall torsional loads that its individual elements would not have experienced. It is not yet possible to quantify the net result of these effects.

From study of the survivors and surviving partially preserved structures, it is becoming increasingly clear that the form was very resistant to earthquake, and that most collapses that have occurred were the result, in part, of damage inflicted in other ways. The behaviour of the best-preserved survivor, the Athenian Temple of Hephaistos, is particularly interesting. Despite the preservation of the complete walls of the cella and of most of the lintels connecting the outer colonnades to them, past earthquakes have caused considerable rocking and displacement of column drums in relation to one another, as seen in Figure 3.61. Yet there has been no resultant collapse. The Temple of Apollo at Bassae has lost part of its epistyle, but is otherwise

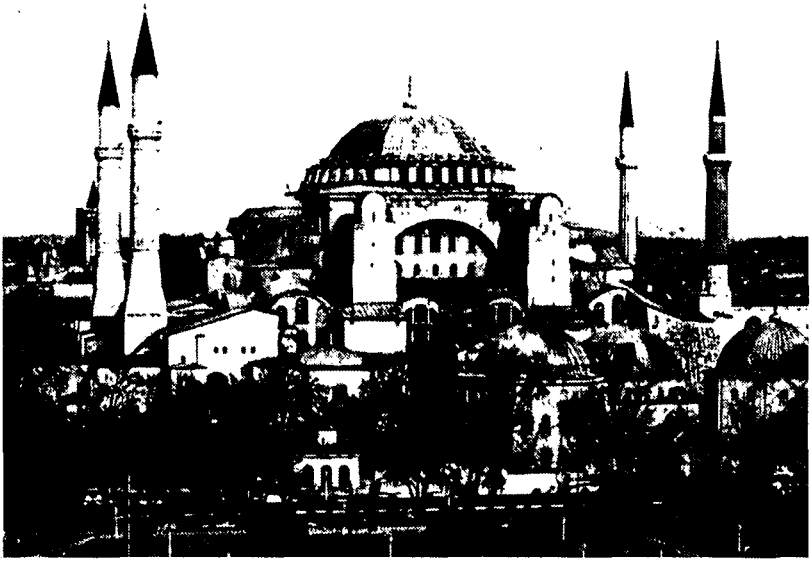

3.56 Hagia Sophia, Istanbul, from the south

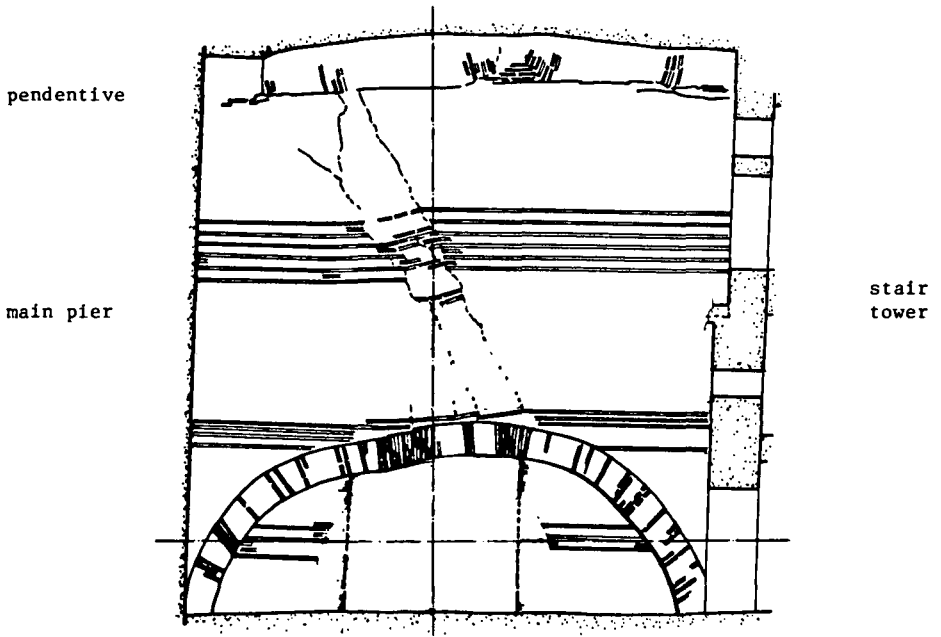

3.57 Part elevation of a high-level buttress, Hagia Sophia, Istanbul

3.58 Northern buttresses
Hagia Sophia, Istanbul



3.59 Western buttresses
Hagia Sophia, Istanbul



3.60 Olympieion, Athens



3.61 Hephaisteion, Athens



3.62 Temple of Apollo, Bassae

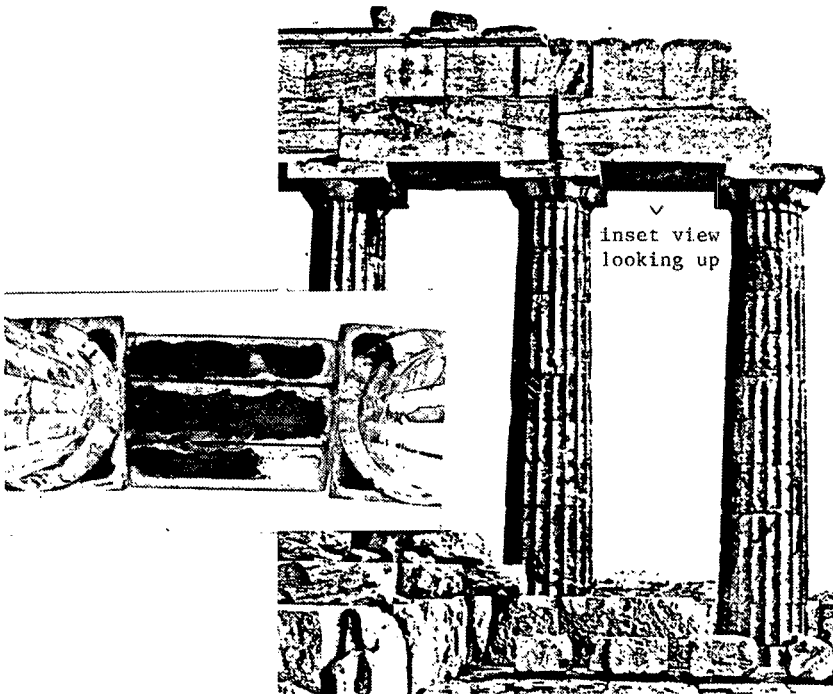

3.63 Details of south colonnade, Parthenon, Athens

largely intact. Equally significantly, it survived unharmed the 1965 earthquake which badly damaged nearby Andritsaina in spite of the fact that erosion of the rock on which it stands by an underground aquifer has led to the tilting of many of its columns, as seen in Figure 3.62.

Further collapse in an earthquake is possibly a real risk only for a structure that has already been seriously damaged in some other way. The case study of the Erechtheion refers to the extensive damage from fire and from an ill-advised earlier intervention that led to doubts about its safety. Present concern for the safety of the Parthenon stems similarly from the clear evidence of similar damage, plus the damage done by the explosion that blew its centre apart in 1687. Figure 3.63 shows the columns at the east end of the break caused then in the south colonnade. The end column is twisted and so is the epistyle above it. A column in this position will, moreover, be subjected to additional side load at the top from any ground shaking at right angles to the colonnade.

3.13 Arcades

The arcade - a sequence of arches carried on piers or columns - was the usual alternative in the past to the colonnade spanned by straight lintels. It was employed wherever spans exceeded those that could economically be spanned by single blocks of stone, and timber, if available, lacked the necessary strength or was considered insufficiently durable. On the largest scale it was used for bridges and aqueducts. On a smaller scale it was used widely in buildings, sometimes in several tiers as seen in Figure 3.38 (which shows only the top two of three tiers). Usually then it carries some superstructure. But sometimes it stands alone as seen in Figure 3.64. Usually it is straight in plan as seen here. But curved arcades were frequently used in circular or oval buildings like theatres and amphitheatres. The arcade at the right of Figure 3.65 (of which the right hand arch has fallen) is an example that previously carried a heavy superstructure.

The single arch on its supports, as seen at the left of Figure 3.65, is the essential component. It is also the smallest unit that must be considered when asking how any arch will behave unless the arch spans directly from rock to rock. The shape and loading determine how the arch will thrust outwards on the supports, and their stiffnesses determine how much they will give way in resisting the thrusts. Earthquakes may be particularly hazardous for the single-arch system if the horizontal ground accelerations lead to out-of-phase movements of the supports in the direction of the span, and if separations of the supports from this cause coincide with downward vertical accelerations.

The effect of constructing arches on both sides of a support is to neutralise the horizontal thrusts if both are similar in form, similarly loaded, and in a straight line in plan. Thus, for static vertical loading, all but the end supports of a straight arcade are free of lateral thrust and can be much more slender than would otherwise be necessary. This does, however, make the arcade more vulnerable to transverse seismic loading unless it is suitably braced. If, on the other hand, an arcade is curved in plan, the lateral thrusts do not completely neutralise one another, but there is a little less vulnerability to horizontal seismic loading on account of the horizontal arching action that becomes possible in the arcade as a whole.

In practice, many smaller arcades incorporated ties across the arches, which, if still effective, will neutralise all lateral thrusts from the arches. Since stronger end supports were usually still provided, their intention may have been chiefly to facilitate construction of the arches one by one.

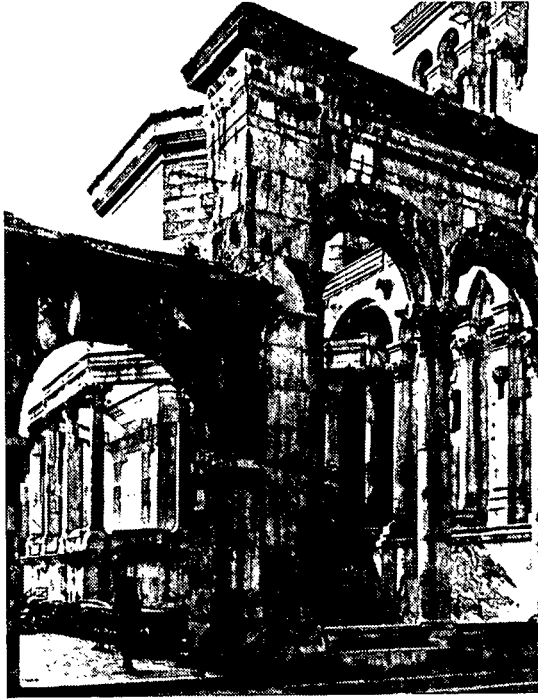

3.64 Detail of peristyle, Diocletian's Palace, Split



3.65 Circular structure, Asklepieion, Pergamon

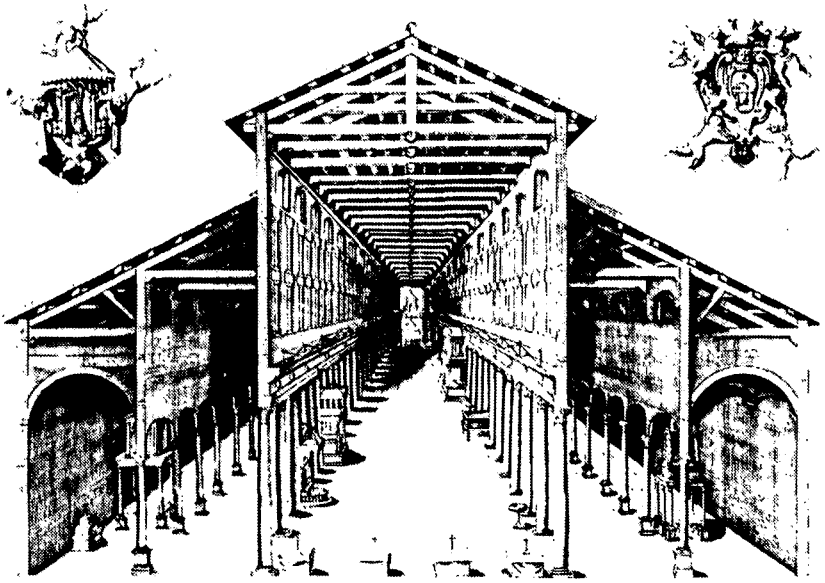

3.66 Old St Peter's, Rome (Ferrabosco after Tasselli)



3.67 Hagios Dimitrios, Thessaloniki

3.14 Halls with open non-thrusting timber roofs

The principal surviving structures of this kind in the Balkans are early basilican churches and some Seljuk mosques. The latter typically have prayer halls of approximately square plan. Within the enclosing walls, rows of columns in each direction support the roof and are braced against overturning by their connections, through the roof system, to the outer walls. The height is not great in relation to the plan dimensions, so the seismic performance should be good if the structure is in good repair.

The basilican church may also be approximately square in overall plan. But it is divided internally in the transverse direction only, sometimes into five aisles as seen in Figure 3.66 and sometimes into three only. To light the interior, the roof of the central section is raised to a considerable height on walls carried at ground level by open colonnades or arcades and perforated by windows above the lower outer roofs, as also seen in Figure 3.66. These walls have little lateral stiffness in themselves, and are prone to lateral buckling even in the absence of transverse seismic loads and outward thrusts from the roof. An instance may be seen below from Ravenna. Their low stiffnesses result, however, in low natural frequencies, which will usually reduce any transverse seismic loads. In some churches also, they are braced by the floors of galleries built over the outer aisles, as seen in Figure 3.67.

The chief risk of earthquake damage is probably of separations at the joints between longitudinal and end walls, and between any stiffer section of wall and the adjacent walls - for instance of each side of a projecting apse. This was the pattern of damage observed at the Church of Acheiropoitos in



3.68 South side of the nave, S. Apollinare Nuovo, Ravenna



3.69 Separations in the northeast corner, Acheiropitios, Thessaloniki

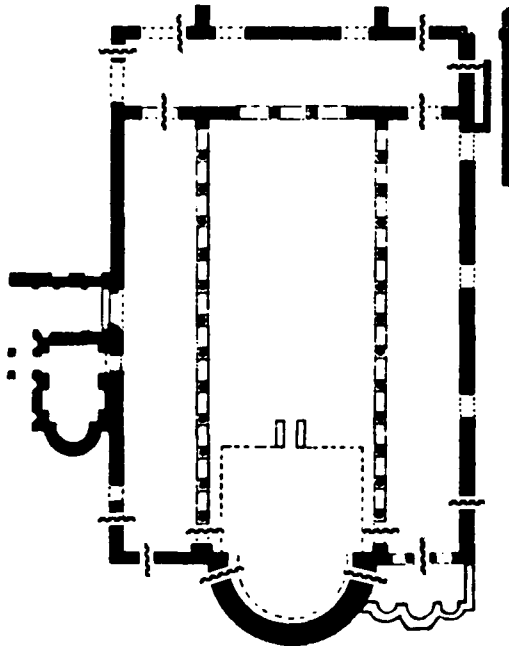

3.70 Principal cracks and separations, Acheiropitios, Thessaloniki

Thessaloniki after the 1978 earthquake, as illustrated in Figures 3.69 and 3.70. The breaks allowed the separated sections of wall to incline outwards, only outward movements being possible to any significant extent. Had these movements been somewhat greater, some of the roof trusses might have fallen. Where roof trusses are no longer effectively tied at the feet of the rafters, their outward thrusts will, of course, make the longitudinal walls more likely to incline outwards and perhaps collapse. It is therefore important that the ties should be in good repair, and preferable that they should also be anchored to the wall heads.

3.15 Vaulted halls

Barrel, groined, or ribbed vaults often took the place of open timber roofs, or were constructed as fireproof ceilings beneath them, to remove the risk of fire associated with the open timber roof. The simplest vaulted structure is illustrated at the left below. It is the longitudinally extended counterpart of the arch on two piers seen to the left on Figure 3.65 and will behave similarly.

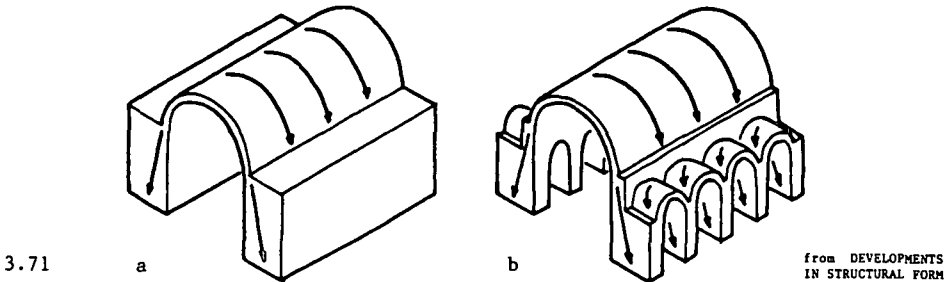

It is rarely encountered except in domestic buildings. Much commoner is the the corresponding counterpart of the arcade. The plan below shows examples along both sides of the large entrance courtyard at the left. The enclosed range served as guest rooms and the open one as stables. Because the thrusts of the vaults neutralise one another as in an arcade except at the ends, it was possible to support the vaults of the stable range on pairs of arches only, in all intermediate positions.

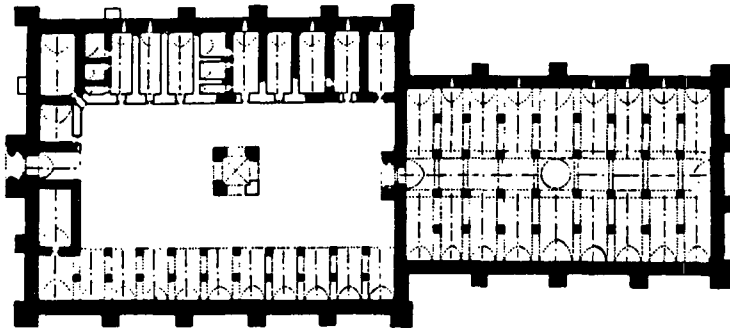

3.72 Seljuk caravanserai, Sultan Han, near Aksaray

It was realised, moreover, that the arcade-like range of vaulted bays could very efficiently support a higher vault aligned at right angles to the bays, as sketched to the right of Figure 3.71. This was the arrangement adopted for the large covered hall of the caravanserai shown in Figure 3.72.

The groined vault supplanted the barrel vault in later Roman architecture, and the same sequence was repeated in the great wave of church building in Western Europe in the 12th and 13th centuries. It is found in the Balkans chiefly in later basilican-plan churches like the Cathedral of Dubrovnik and the Calvinist church of Bekes described in the case studies. As shown in the sketches below, it permits a more localised provision of support and permits a similar relationship of central nave and side aisles to that of the earlier basilican church with open timber roof. Structurally it calls for efficient buttressing of the vaults over the aisles. But the possibility existed, and was sometimes exploited, of using ties as sketched at the right to reduce the need.

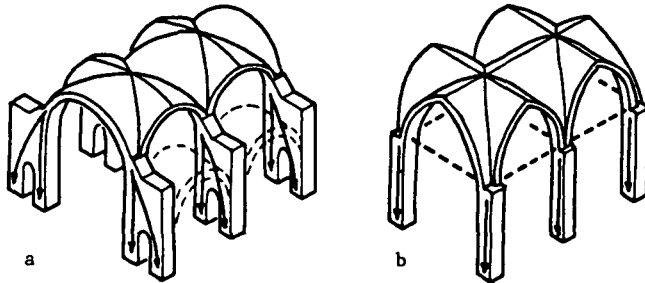

3.73

from DEVELOPMENTS
IN STRUCTURAL FORM

The characteristic type of damage is again an outward inclination of the supporting elements, with associated cracking of the connecting arches and the vaults and some dropping of their crowns. These are likely to have occurred even without an earthquake, but will be accentuated by one. The case studies describe instances of relatively light damage, well short of actual collapse of vaults or supporting piers. Figures 3.74a and 3.74b show badly damaged piers after all the main vaults have collapsed. The structure was originally the caldarium of a Roman bath, probably with a high central vault spanning the whole distance between the heavy piers seen in the upper view. After the collapse of this vault, the structure was later restored to serve as a church, with the central span now reduced by the construction of the inwardly projecting extensions to the piers seen in the lower view. It has still to be excavated to determine the forms more precisely, but it serves to illustrate one kind of collapse to be guarded against even where the supports are originally very stiff.

Another risk to some older structures of the kinds discussed here arises from erosion of the outer surface of the masonry or walls or piers at ground level - either natural erosion or, if the structure is partly ruined and unused, by robbing of facing stones. This considerably reduces the stability.

3.16 Centrally planned domed structures

The simplest structure of which a central dome is the dominant feature consists of no more than the dome and a circular wall beneath to carry it, as already illustrated diagrammatically in Figure 3.41b. In practice, the circular wall has often been hollowed internally in its lower part as in the



a



b

3.74 Extramural bath converted to a church, Hierapolis

Roman Pantheon, its smaller counterpart shown in Figure 3.76, and the sketch to the left below. The Rotunda in Thessaloniki, described in the second case study, was also originally of this form before a large opening was cut to give access to the Christian chancel. Many Seljuk tombs are further examples of the form on a smaller scale except that, as seen in Figure 3.77 and in the indications of the likely original form in Figure 1.3, the dome is surmounted by a conical outer vault which was often carried partly by a fill of horizontally coursed rubble resting on the dome.

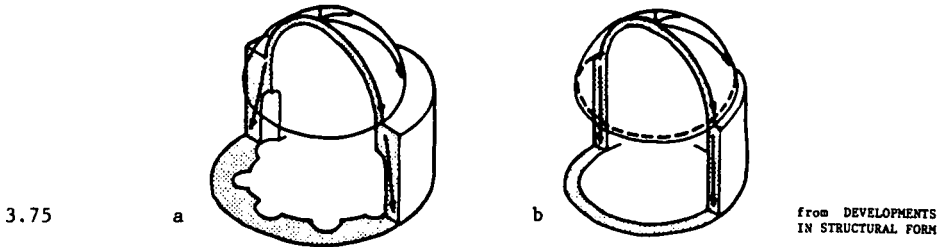

In principle, all bursting tendencies could have been contained by a circumferential tie as sketched to the right above. Dome and supporting wall could both then have been reduced in thickness, and there would have been an excellent resistance to earthquakes on account of the double curvature of the dome. In practice, effective circumferential ties were lacking, so the behaviour is more that of a ring of arches on supporting piers as indicated in Figure 3.41b. With high quality masonry, the behaviour is nevertheless still better than would be that of the component arches individually, as illustrated by Figure 3.76. Damage to the Rotunda in Thessaloniki was made worse by the alterations to the original structure and by the extent to which even the original circular base structure was hollowed out, both to the interior and within the thickness. Damage to many Seljuk tombs is probably attributable partly to long exposure and weathering of the binding mortar and partly to the massiveness of the double vault and its height above the ground.

In other centrally planned domed structures the dome is supported on isolated piers spanned by arches with either pendentives or squinches as transitional elements. The core of the structure is then as sketched in Figure 3.78, or some variant of this.

Several references have already been made to the prototype of this form - the 6th century rebuilding of the Church of Hagia Sophia in Istanbul, now known as Aya Sofya. Here, large semidomes abut two of the the arches that carry the dome as seen in Figure 3.79 and Figures 3.45 and 3.46. The whole central vaulting system and its pattern of behaviour are also sketched in Figure 3.48 and described in the accompanying text of section 3.9, and the buttressing system to the north and south is described and illustrated in section 3.11. For a structure of this size, and with the dome high above the ground, the inertia forces due to earthquake become more serious than for a smaller structure, as does any out-of-phase shaking of the main supports. Three partial collapses of the dome are, in fact, recorded after earthquakes, though probably none of them should be attributed solely to the earthquake. The first certainly occurred partly on account of the rapidity of the original construction, which allowed insufficient time for the mortar to harden as loads increased and before the first earthquake shocks. It occurred through inclinations of the main supporting piers to north and south and the dropping down



3.76 'Tor de Schiavi', Rome

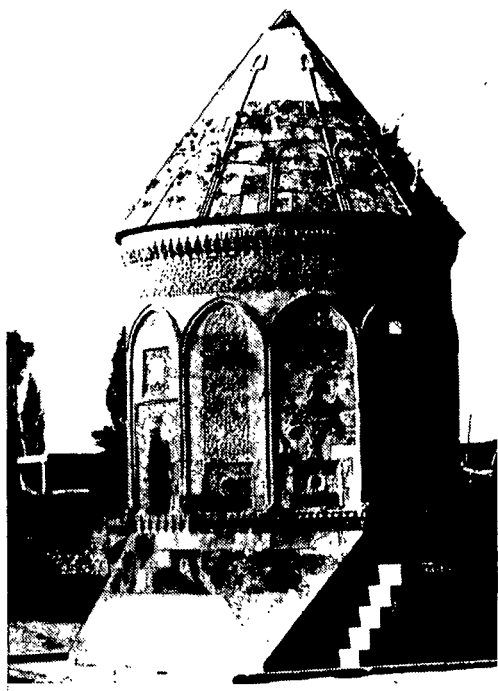

3.77 Doner Kumbet, Kayseri

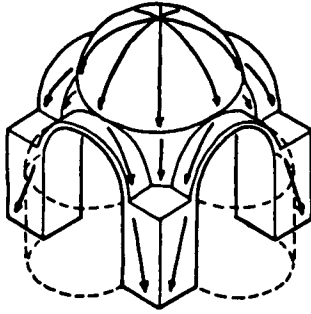

3.78

from DEVELOPMENTS
IN STRUCTURAL FORM

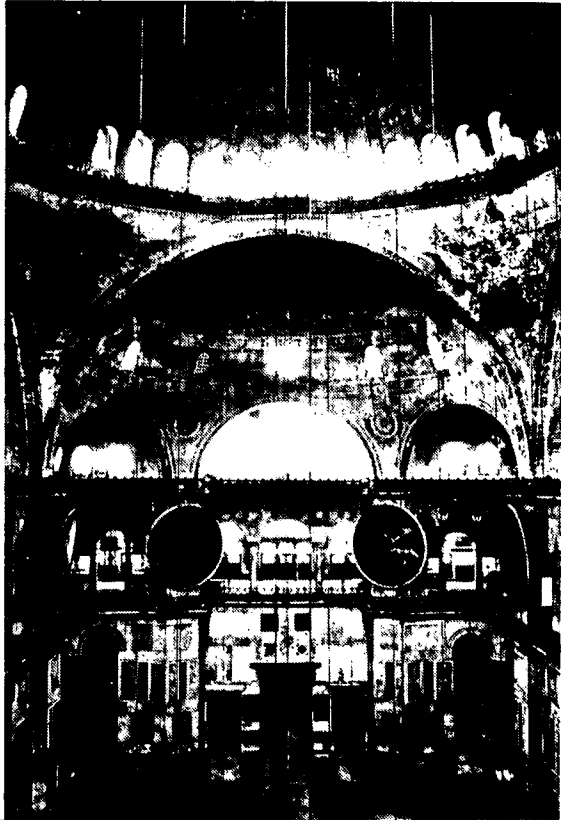

3.79 Hagia Sophia, Istanbul, looking westwards

of the crown of the main eastern arch after the earlier development of cracks like those seen in Figure 3.44. Today the structure is more heavily buttressed and more secure.

Later Byzantine churches were all much smaller, mostly only a small fraction of the size of Hagia Sophia. For that reason alone, stresses due to earthquake loading will be substantially smaller. From the 9th century onwards, the 'cross-in-square' plan was adopted. An example is shown in Figure 3.80. Here the dome and the four supporting arches, corresponding to those of Figure 3.78, are marked by single hatching. With a much reduced weight to be carried, the four piers become the four small square bays marked by crossed hatching, in which the vertical weight of the dome is carried by single columns and all side thrusts by the enclosing outer wall, though systems of ties were usually introduced in addition as shown in Figures 3.51 and 3.52. Outward thrusts due to normal vertical loads are, in any case, small. Under seismic conditions, the horizontal inertia loads due to horizontal ground accelerations are likely to present the main threat, in view of the tendency to increase the height of the structure and to add to the central dome others in the outer corners which were similarly raised on high drums. The primary damage is therefore likely to be cracking apart of the side and end sections of the enclosing wall, much as in the open roofed basilica or in multi-storey buildings.

There were two important subsequent uses of the basic form sketched in Figure 3.78. One was as the crowning feature of a vaulted church of basilican plan. An example is discussed in the case study of the Cathedral of Dubrovnik. The other was in the Ottoman mosque.

Early Ottoman mosques consisted of several domed square bays open to one another internally. Here, the thrusts of adjacent domes neutralised one another in the same way as the thrusts of adjacent arches in an arcade, though construction of the domes one-by-one was usually facilitated by making all the piers of equal cross section.

The later centralised form was closer to Hagia Sophia in plan and in structural system. Some Imperial mosques, like the Sulcymaniye Mosque in Istanbul, bore a very close resemblance. Others, like the Mosque of Sultan Ahmet illustrated in Figures 3.82 and 3.83, were more completely centralised. They have buttressing semidomes on all sides of the dome, as shown by broken lines in Figure 3.78. These mosques were also well constructed, with a greater use of cut stone for the high-level arches and thin mortar joints to reduce the deformations that occurred during construction, and with a very extensive use of iron ties across all arches. They should, therefore, behave more like the form sketched in Figure 3.75b in an earthquake, and have in fact performed well hitherto.

3.17 Minarets and towers

The minaret is usually of tubular form, tall and slender, and with a stair ascending in the centre of the tube. It rises from a more solid base, and has one or more slightly projecting platforms as seen in Figures 3.56, 3.58, and 3.82. Some minarets are built of brick, others of well dressed squared stone.

The seismic behaviour will approximate to that of the tall free-standing column built from superimposed drums, especially if the bed joints of the masonry are continuous over the cross section and constitute planes of weakness. The long natural period of vibration will reduce the effective loading, and

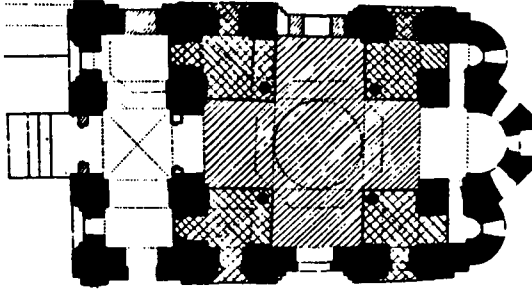

3.80 Panaghia Halkeon, Thessaloniki

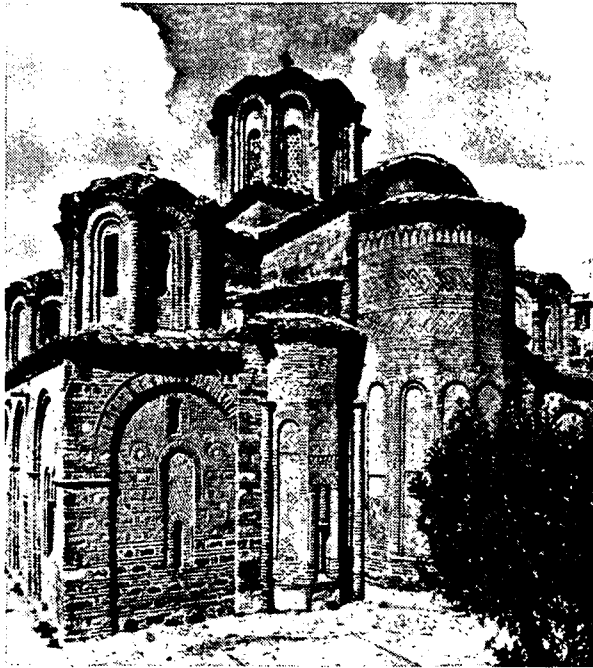

3.81 Dhodheka Apostoli, Thessaloniki



3.82 Mosque of Sultan Ahmet, Istanbul, from the northeast

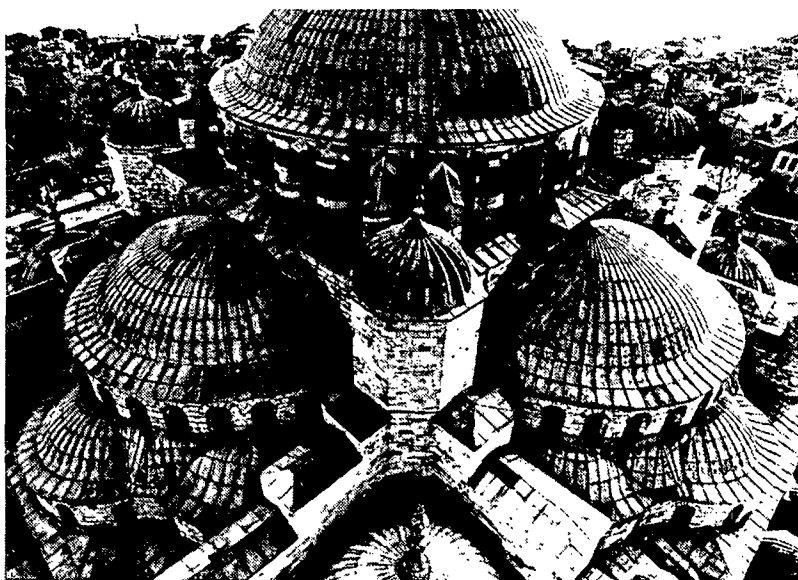

3.83 Dome and semidomes, Mosque of Sultan Ahmet, Istanbul, from the north

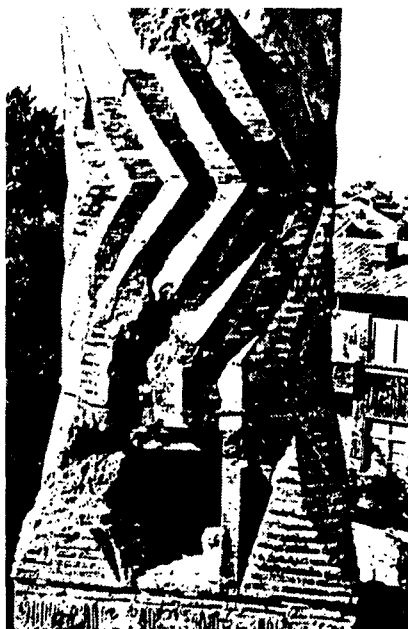

3.84 Minaret of the Imaret Mosque, Plovdiv



3.85 Gradska Kula, Kotor

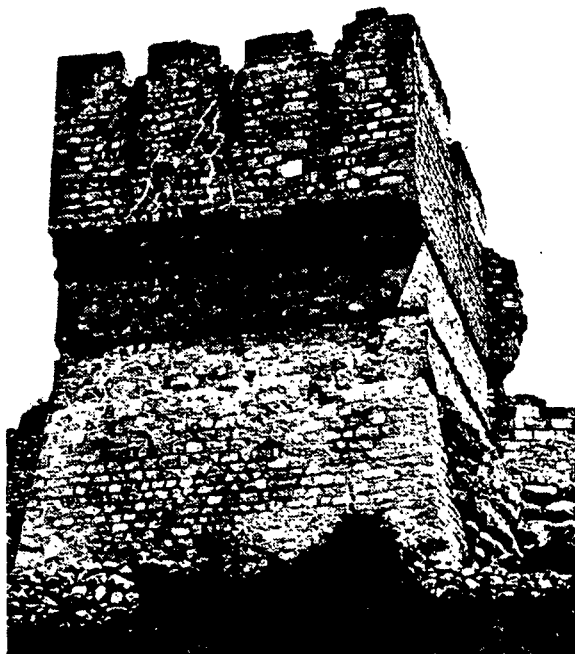

a

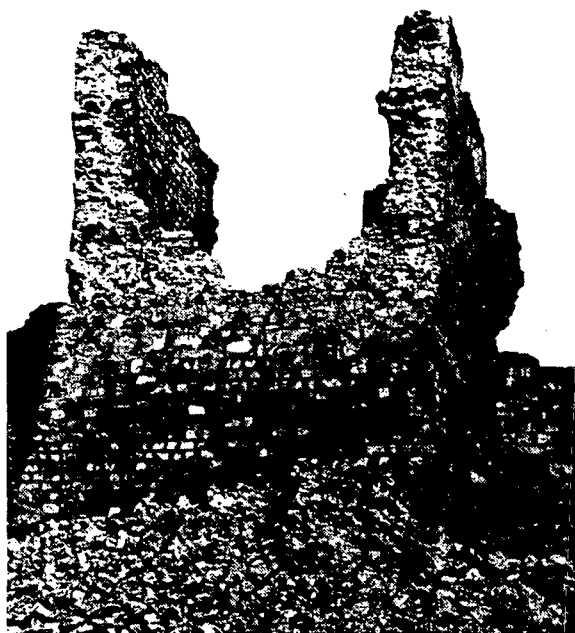

b

3.86 Defence tower, Cherven

the most likely damage will be some lateral displacement at the level of a projecting platform due to slight rocking as in the column. The other risk is of local crushing near the foot if the masonry is relatively weak and the cross section is reduced here, as seen in Figure 3.84, by an entrance to the internal stair.

The tower is a less precisely defined form. The term is used here to cover structures that are taller than they are broad, have almost constant overall dimensions in plan throughout the height, and consist largely of a single continuous outer wall. They may be square, polygonal, or circular in plan. The most frequent uses are as bell towers - the counterpart to the minaret - or as vantage points in a circuit of defensive wall. There will be a stair to give access to the upper levels and, usually, some intermediate floor or floors and a top floor or walkway with, perhaps, a roof. It is not unusual for construction to have taken place in several stages, and this may be betrayed by a levelling of the upper stage or stages after differential settlement had taken place and led to some inclination of the earlier work, as seen in Figure 3.85.

Both the natural frequency and the characteristic mode of response will vary according to the overall slenderness. For a slender tower, they will be similar to those described for the minaret. For a squat tower, they will be closer to those described below for a multi-storey building of similar construction.

Another factor to be considered is the interaction between a tower and another structure built immediately alongside. The tower will usually be stiffer and more massive and will have a different dynamic response to seismic excitation. There will, as a result, be a tendency for the tower first to pull away from the other structure and then to inflict damage on it by acting as a battering ram. This also is seen in Figure 3.85.

Figures 3.86a and 3.86b show the consequence of a marked change in cross section at the top level.

3.18 Multi-storey buildings

The multi-storey building differs from the squat tower in having internal bearing walls as well as external. Most floors span for shorter distances than the full width of the building, bearing on one side at least on an internal wall. Most walls, internal and external, are interrupted at each floor level by openings for doors or windows. Walls are usually of the types described in sections 3.3.4 and 3.3.5. Floors are usually of timber, but they may be shallow masonry vaults in more important buildings. Roofs are almost invariably of timber. Even in old urban nuclei, few structures other than palaces and public buildings are likely to have been built before the 18th century.

Good seismic performance depends on integral response of all walls to the horizontal shear. This calls for adequate tying together of all walls and good diaphragm action of the floor systems. Serious damage and collapse usually result from shortcomings in these respects and from other departures from good overall form - regular and symmetrical plan form, uniform distribution of strength and stiffness, and absence of excessive mass at the upper levels. The latter shortcomings often stem partly from a sequence of modifications to the original structure, including the building of a new structure of markedly different characteristics immediately alongside an existing one - as probably happened in the case already referred to and illustrated



3.87 Bulgarian Renaissance house, V. Tiznovo



3.88 Timber houses, Soguk Cesme Sokagi, Istanbul

3.89 Damaged building, Budva



3.90 Damaged building, Venzone

in Figure 3.85. Poor tying together of the walls and poor diaphragm action of the floors may result either from deficiencies in the original construction or from deterioration and poor maintenance.

Just as the timber-framed wall behaves well, so does the complete timber-framed building or the building with fully timber-framed upper storeys on a well built masonry ground storey as seen in Figures 3.23, 3.25, and 3.87. Integral response is ensured by the connections between the framing members in all planes, shear resistance of the walls by diagonal bracing - see Figure 3.88 - and horizontal diaphragm action by the boarding of the floors. There is also just enough play in the joints to contribute to good energy absorption. Decay of the timber may, however, loosen the joints so much that they can no longer hold the structure together.

Equally good performance of the building with walls of unframed masonry under similar seismic excitation is rarer. Instances of damage are shown in Figures 3.89 and 3.90. The damage in both instances stemmed partly from the absence of transverse ties at the floor levels. In the first case the further cause was the excessive weakening of the external walls on the lines of the window openings. Beneath the windows, the wall thickness was reduced to about half the thickness elsewhere, so that vertical cracks developed in line with each window jamb as seen on the right, and further shaking led to the local collapse seen on the left. A more extensive collapse might have followed if the shaking had continued longer because all possibility of integral action of the whole wall in resisting the horizontal shear was now destroyed. In the second case the further cause was the presence of an open arcade at ground level. Without good tying back to the walls behind at the level of the column heads, this permitted an outward buckling of the wall (the buckled wall being held in place by the shores seen on the right).

An example of damage to a building of individual importance is described in the case study of the Hegemoneion, Samos, while the behaviour of the rector's Palace in Dubrovnik described in an earlier case study demonstrates the value of ties in a situation similar to that shown in Figure 3.90.

4. METHODS OF INVESTIGATION AND ANALYSIS

The investigation and analysis that are a necessary basis for the preparation of any scheme for repair and strengthening assume particular importance when the structure is of cultural or historical significance, and it is therefore desired to preserve the original fabric and character with as little change as possible. The needs that arise at different times, both before and after an earthquake, have already been discussed in sections 2.2 and 2.3. The available methods are now described.

4.1 Visual inspection

Visual inspections must always come first, though it will obviously be helpful, when making them, to have available any previous survey drawings and related records and to have studied these beforehand. Such inspections also have a continuing part to play in the direction and supervision of any intervention.

Initial inspections may be of three kinds:

- those made before an emergency arises for the purpose of listing important structures and assessing their structural condition.
- those made immediately after an earthquake for the purpose of a first rapid assessment of the damage done.
- those made a little later to see what emergency interventions are needed, to assess the damage further, and to plan future action.

The assessment, in each case, will have to be a judgement based on limited evidence interpreted in the light of the engineer's knowledge of the type of structure and its characteristic behaviour, as described in chapter 3. The ways in which the structure is supporting itself and is capable of withstanding future shaking, wind, and other likely loads must be envisaged. Then, bearing in mind what it has already withstood, the ways in which and the extent to which its capacity has been reduced by cracking, crushing, other local failures, tilts, bows, and other deformations or movements, must be estimated.

Close detailed inspection will be necessary chiefly in the third case, but sometimes also in the first case where, at first sight, the structural condition gives rise to concern. Drawings will then be essential for recording observations and building up an adequate composite picture of the condition of the structure as a whole. They are considered further in section 4.2.

Indications of the structural condition to which particular attention should be paid are:

- cracking of masonry. When this is examined, attempts should be made to distinguish between old and new cracks, and between cracks indicative of different types of structural action. New cracks will usually have a sharp clean appearance and show clearly defined separations. Older cracks will have a more weathered appearance and often a less clearly defined separation as a result of past attempts at making good or covering up. Fresh opening of an old crack may show as a separation between a previous filling and one side of the crack proper.

The structural actions may be distinguished both in terms of the local stress conditions and in terms of the action of the structure as a whole and the loading on it. The local stress condition may be excessive bending tension in a spanning element; the secondary tension at right angles to a primary compression that leads to splitting in the direction of the compression in an element of uniform cross section; bursting apart of the stiffer facings of a wall or pier of non-uniform construction under a similar primary compression; combined tension and compression in a wall subject to shear; or tension due to restrained thermal movement or the swelling of corroded embedded iron reinforcements. In terms of the action of the structure as a whole, cracks that indicate the directions of primary compressions in masonry are the most revealing, since these compressions will be the principal internal actions resisting the applied loads, Relative movements across such cracks are further clues to the structural action, as are overall relative movements of masses of masonry separated by families of cracks.

The overall pattern of cracking, together with the relative movements, should help to distinguish between long-term action under dead load, action under seismic or wind loads, response to differential settlements of the foundation, and the effects of restrained thermal and similar fluctuations.

- crushing of masonry. Pure crushing indicates local stresses much in excess of the average that is likely to be found, or local weaknesses such as badly underfired bricks in a brick wall. High local compression is more likely to lead to local splitting or spalling.
- deformation of arches and vaults. This will always be found to some extent, and will be accompanied by visible openings of joints and/or local slips at joints (as seen in Figures 3.36 and 3.37, though usually to a less pronounced degree), unless the deformation is all accommodated by a weak mortar. If the arch or vault is a main spanning element, there will usually be a spreading of the springings and some associated change in the thrust exerted. This behaviour is discussed further in sections 3.7 and 3.13.
- tilts of walls, piers, and columns. Like cracks, tilts may be long-standing or (at least in part) new, and they assist further in identifying the structural action. Apparently anomalous tilts probably indicate that the elements in question are not part of the primary load-bearing structure, or that these elements are later additions or have been rebuilt after some tilting had already occurred.
- differential settlements, as shown by changes in levels.
- slips or failures of tie members.
- other weaknesses or failures of the joints of timber frames.
- the manner of construction of masonry and its general condition.
- the condition of all structural timber.

Judgement of the significance of particular clues will become easier as the whole pattern emerges. Diagnosis will be facilitated, however, if the engineer continually asks himself what each fresh piece of evidence means and formulates tentative hypotheses about the overall behaviour from an early

stage. He should then test these hypotheses against further observations and modify and refine them as necessary.

Where there are decorations or other contents of importance, the condition and safety of these should also be inspected. Visible internal cracking will, of course, be that of decorative finishes where these exist unless they have become completely dislodged. But there is a further possibility (and on curved surfaces such as vaults a likelihood) of the whole plaster bed of a mosaic or fresco becoming separated from the masonry behind. This both poses a threat that it may fall and means that, while it remains in place, the full extent of cracking of the masonry is hidden. Where such separation does seem possible, it may be tested by gently pressing against the surface if nothing can be seen through cracks and other breaks in the plaster.

The chief purpose of later visual inspections during the preparation and execution of schemes of repair and strengthening will be to extend and either confirm or correct the initial observations and conclusions as more is made visible by exploratory cutting and other work.

4.2 Structural survey

By a structural survey is meant a precise record of the types of evidence discussed above. Measurement is called for, and the basic record should take the form of measured drawings. An architectural survey will probably also be necessary and may already exist. If so, it can serve as a framework, though additional cross sections may be necessary. For the representation of structural deformations such as inclinations from the vertical, further drawings may be desirable, with the deformations plotted to an exaggerated scale. To assist in a complete three-dimensional visualisation of the structure and its condition, a three-dimensional model may also be helpful. If it is made of transparent plastic, it can be used to give a simultaneous view of significant visible cracking on all surfaces and to show, for instance, how cracks penetrate through a wall or pier.

Figures 4.1 and 4.2 show a transparent three-dimensional model of the Rotunda in Thessaloniki, and one drawing made to record the cracking observed after the 1978 earthquake. It shows cracks on the outer wall of a helical stair within the thickness of the pier seen in the centre of the view of the model.

In addition to the techniques used in normal architectural survey (including photogrammetry), the following are suggested:

- for the initial measurement of crack widths, a millimetre scale should usually be adequate since high accuracy is not required and it is more important to ensure that the full true width is recorded and not just the surface width of a crack that has previously been filled. A crack microscope may, however, be easier to use. The direction and depth of penetration can be determined by inserting suitable slightly flexible steel rods, or the depth alone by ultrasonic tests.
- for the initial measurement of deviations from the vertical or horizontal, the simplest methods again suffice because the true datum for the measurements - the initial form - is not precisely known. Plumb line or theodolite or photogrammetry may be used for the first, bearing in mind the need for protection of a plumb line from any wind and the possible desirability of damping of the swing of the bob to speed its use. An ordinary level will do for measuring deviations from the horizontal.

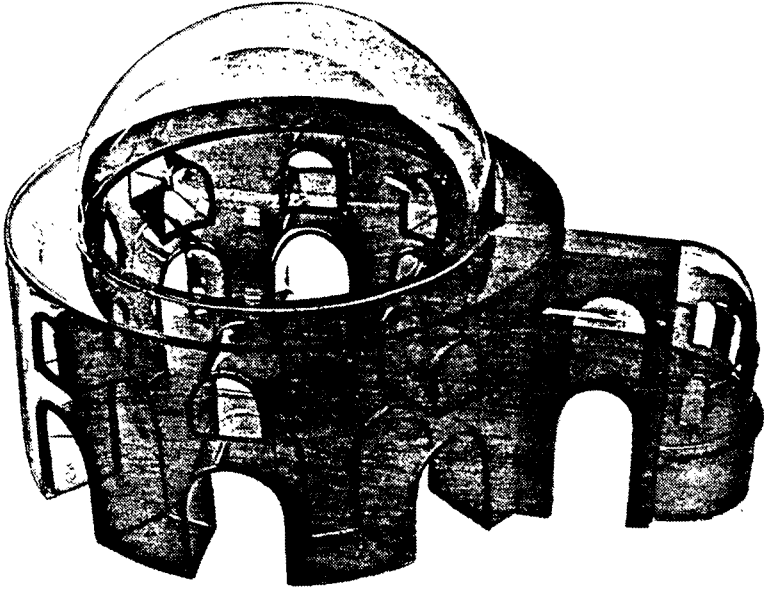

4.1 Model of the Rotunda, Thessaloniki

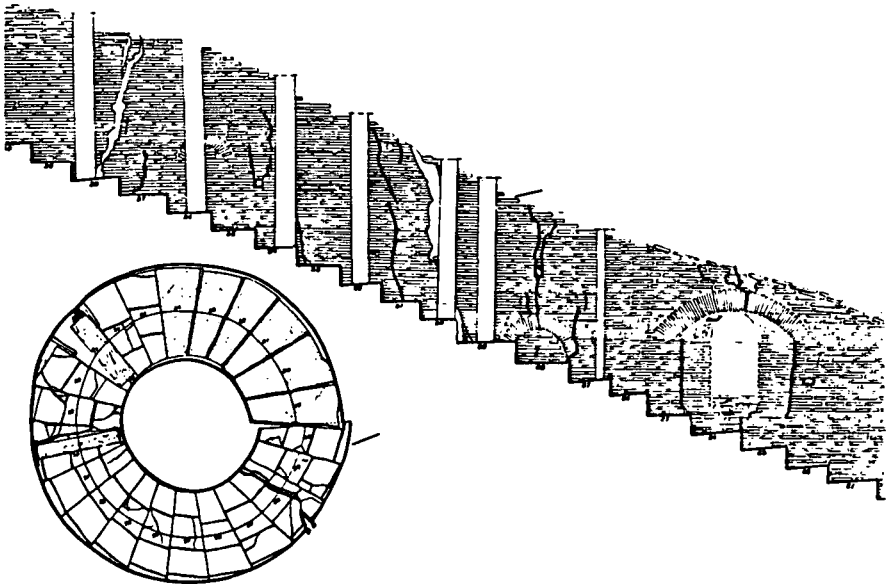

4.2 Survey of cracking, internal stair, Rotunda, Thessaloniki

There will be a greater need than in a purely architectural survey for information on foundations, on the thicknesses of vaults, on the construction of walls and piers through their thicknesses, and on the presence of any buried reinforcements.

Wherever possible, this information should be obtained by observation or measurement through existing holes, breaks, and other points of access. Where it cannot be obtained in this way, it will be given most reliably by drilling or digging trial holes. An alternative technique for detecting buried metal reinforcements is gamma radiography. This calls for specialist operation and interpretation. An example of its use is reproduced below.

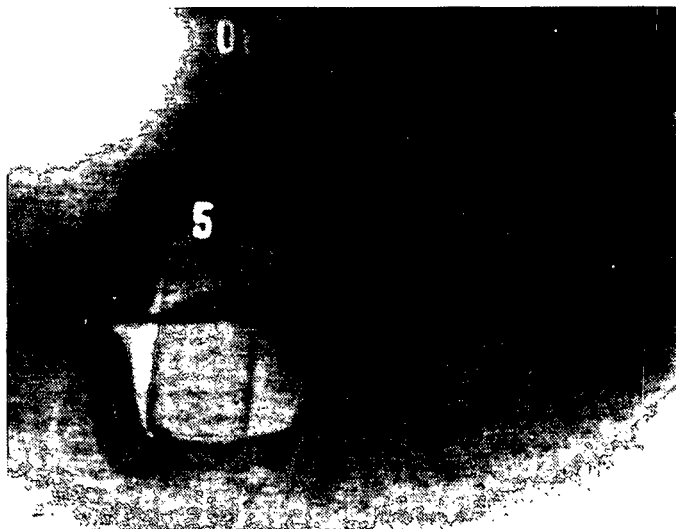

4.3 An iron dowel detected by radiography on the Erechtheion, Athens

4.3 Continued recording, tests on materials and soils, etc.

A structural survey such as has just been described (or a simplified version of it where that is all that is called for) will provide much of the information on which analyses of seismic resistance and decisions on the need for repair and strengthening must be based. The chief further needs that may arise are for information on the properties of the structural materials, information on overall dynamic structural characteristics and on ground conditions, and information on whether cracks and tilts etc. are increasing and, for that reason, dangerous.

4.3.1 Continued recording of significant movements

The mere presence of a crack signifies a local loss of strength and a consequent reduction in the resistances that can be mobilised. It also introduces a freedom of movement. This freedom is not always undesirable or dangerous, and even when it might be, movement is usually restrained by resistances developed elsewhere. A serious situation arises when continued move-

ment seems both a possibility and a likely threat to stability. Such a situation may also arise through continued movements not associated with visible cracking.

When such situations are suspected, continued observation is desirable (after, of course, taking any emergency measures necessary to prevent major further movements and collapses). Changes in crack widths are the easiest to record, provided that there is easy access to suitable points of measurement. Direct recording of significant movements of structural elements may be more time consuming, but it gives a more immediate indication of possible danger. The most significant are usually inclinations from the vertical of principal supports.

No structure remains completely at rest. Small movements take place continuously with changes in load, changes in temperature, etc. Movements due to changes in temperature tend to have both daily and annual cycles. Since cyclic movements are not of concern, but only the continuous trend, measurements must continue for long enough and be so planned as to distinguish the continuous trend from the short-term and longer-term fluctuations around it. They should continue, if possible, for at least a year, and be taken preferably at fixed intervals and at a fixed time of day. Some of them may, with advantage, be continued during strengthening to monitor the effects of this. See the Figure below and Figure 8.8.

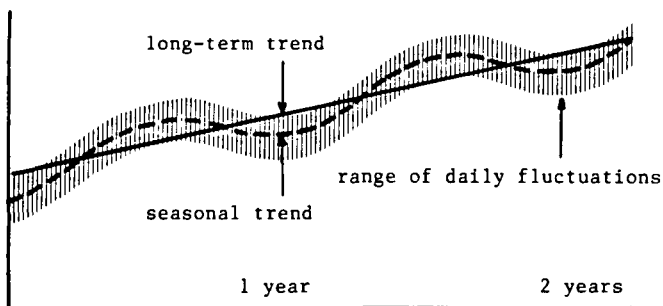

4.4 Structural movements: typical fluctuations around a long-term trend

Much higher accuracy is called for now than in the basic structural survey, since the rate of movement is likely to be small and the datum is the situation when measurements start and not the unknown original state of the structure. An accuracy of 0.1 mm is desirable for crack measurements and 1 mm for out-of-plumb and out-of-line measurements.

The desirable accuracy of measurement of crack widths is unlikely to be attained by direct measurement to the edges of the crack because of the difficulty of identifying these consistently and precisely. Measurement to marks scribed to each side, using a crack microscope, is possible in skilled hands. But it has the drawback of allowing only measurement of the width. The best technique is to glue small metal studs in isosceles triangular formation, two on one side of the crack and one on the other, and then to measure the two distances across the crack by means of a screw micrometer or a dial gauge adapted for this purpose. From these measurements, both changes in width

and relative movements parallel to the crack can be calculated.

For continued out-of-plumb measurements, the plumb line can be used if sufficient care and time are devoted to minimising errors. Optical plumbs are more convenient to use if light is adequate and good targets are fixed at the upper and lower levels in each position. (These operate on the principle of viewing the targets vertically through prisms from an intermediate position, the verticality of the lines of sight being controlled by a spirit level.)

4.3.2 Tests on materials

The calculation of strengths and responses to seismic excitation calls for knowledge of the densities, unit strengths, and moduli of elasticity of the materials. Damping properties are also relevant, but these depend on much more than the properties of the materials and will be considered in section 4.3.5. For the purpose of assessing the long-term suitability of materials such as grouts to be used for strengthening or repair, knowledge of the chemical composition of the existing materials may also be required.

Three difficulties confront the engineer responsible for an old existing structure, in place of the uncertainties that arise when a new one is designed. The materials are already in place, with their own specific properties. But:

- there may be difficulties in extracting samples suitable for test.
- there is likely to be less homogeneity and uniformity of construction, particularly in walls and piers, so that overall strengths will be less predictably related to the unit strengths of the constituent materials.
- there may be considerable variation in the properties of a particular type of material, or of the way in which the individual materials contribute to the strength of a composite element.

For chemical tests the extraction of samples is essential, but the samples can be small enough for this to present few problems.

For reliable values of strengths or moduli of elasticity, larger specimens are essential for the normal laboratory tests prescribed by codes. It may therefore be necessary (either in place of these or alongside them to give a more representative sample) to carry out in-situ non-destructive tests. The most suitable types of test (if suitably calibrated) are rebound hammer tests for strengths of masonry, and ultrasonic pulse velocity measurements for dynamic moduli of elasticity. Examples of such tests are referred to in the case study of the Rotunda, Thessaloniki.

For determination of the strengths of compound masonry, the empirical relationships with the strengths of brick or stone and mortar that are given in codes of practice can be used if the construction is uniform throughout the thickness. Where this is not so, the core will usually be weaker than the facings, and a reasonable lower limit to the compound strength may be given by ignoring the core - at least until it has been grouted and perhaps reinforced. An alternative, which may be possible where some structural remodeling is contemplated or where there are numbers of similar structures, is to perform in-situ tests on sections of wall that have been partly cut free for the purpose. An example of such a test to determine shear strength of a wall of fairly uniform construction is shown in Figure 4.5 overleaf. A

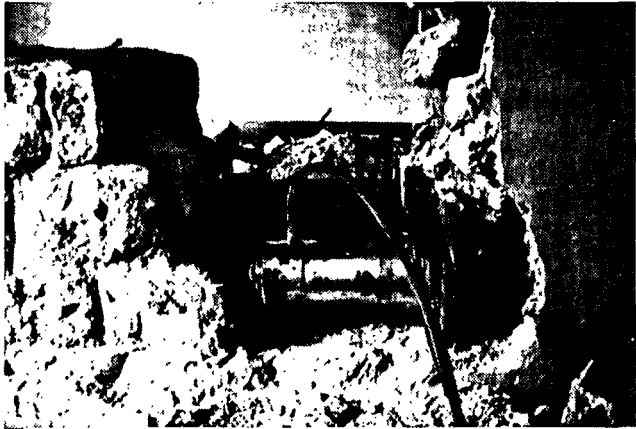

a

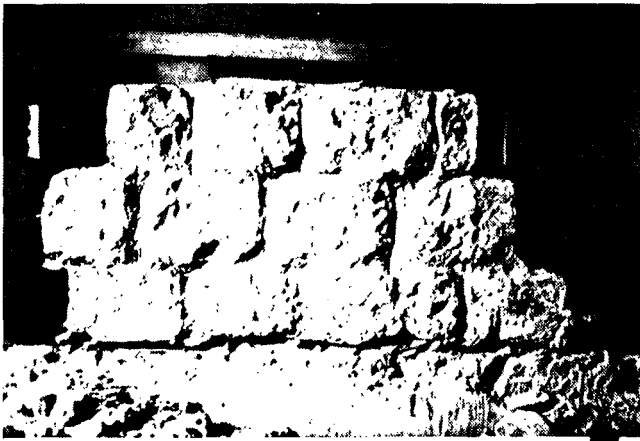

b

4.5 In-situ test of a wall of the Rector's Palace, Dubrovnik

section of the wall was first cut free at the top and both sides. Lateral load was then applied by the jack seen in a, causing the failure along the bed joint seen in b. In the absence of top load, this will give a lower limit for the shear strength of the masonry.

Likely variability of properties may, with experience, be roughly estimated from an inspection of workmanship, variability of surface (including differential weathering), and distribution of cracks. Unless extensive coring or other extraction of samples for test is possible, the most reliable indications will be given by in-situ rebound hammer and ultrasonic tests.

Because of the limited data at present available on the strengths and stiffnesses of typical types of walling found in old structures and on their variability, it would be helpful if any extensive series of tests of possible

wider validity were published.

4.3.3 Measurements of existing stresses

The highly non-uniform distributions of stress that are typical of old masonry construction have already been referred to in chapter 3. In addition to the local variations that result from inhomogeneities and uneven bearing, actual stress distributions will also reflect the sequence of construction and the whole history of loading of the structure. Where it is suspected that high local stresses may seriously reduce the capacity to withstand future loading, direct measurement may be desirable.

In principle, this calls for releasing the existing stress in a small piece of the masonry and for measurement of the strain reduction. The technique is to attach a strain gauge to the face, then cut out a wedge by drilling above the gauge and (diagonally) at each side. Readings are taken on the gauge before and after drilling. Measurements made in this way in the past have indicated stresses up to 4.5 times the calculated value even in the well constructed and apparently uniformly stressed masonry of a 19th century tower.

4.3.4 Soil tests

Where existing information is insufficient to take local soil conditions into account in estimating seismic loading, boreholes should be drilled to determine the stratigraphy and the maximum ground water level. The number required will depend on the ground conditions and the depth should be related to the width of the foundation. Usually there should be at least one borehole per 100 m² cut to a depth of at least 5 m below the foundation.

For each layer, laboratory tests should be made to determine grain content, mass density, voids ratio, and moisture content.

Where ground conditions are suspect, additional tests may be required.

Standard penetration tests or other appropriate tests may also be desirable for the estimation of bearing capacities.

4.3.5 Other tests relevant to seismic loading

The elastic response of a structure to seismic loading depends on its natural frequencies and damping characteristics. Post-elastic response depends also on ductility. For design, it is usual to assume values of seismic loading that take any capacity for post-elastic response into account. Thus it is necessary to know at least the fundamental natural frequency or period and either the damping ratio and ductility ratio or a factor that combines these two. Mode shapes may also be required.

None of these characteristics can, in practice, be determined by test with great accuracy - the ductility ratio because the test would have to be carried close to failure, and the natural frequency and damping because these vary with amplitude so that the tests should really be conducted at amplitudes approaching the end of the elastic range.

Natural frequencies at low amplitudes can be determined from seismograph records of ambient vibrations. Mode shapes can also be determined from relative amplitudes if simultaneous records are taken at several heights. For simple forms like towers, the fundamental frequency should be clearly defined as in Figure 4.6 overleaf. For more complex forms like some multistorey buildings,

it may be less clearly defined as in Figure 4.7. The lowest frequency at which there is a peak response should then be taken as the fundamental.

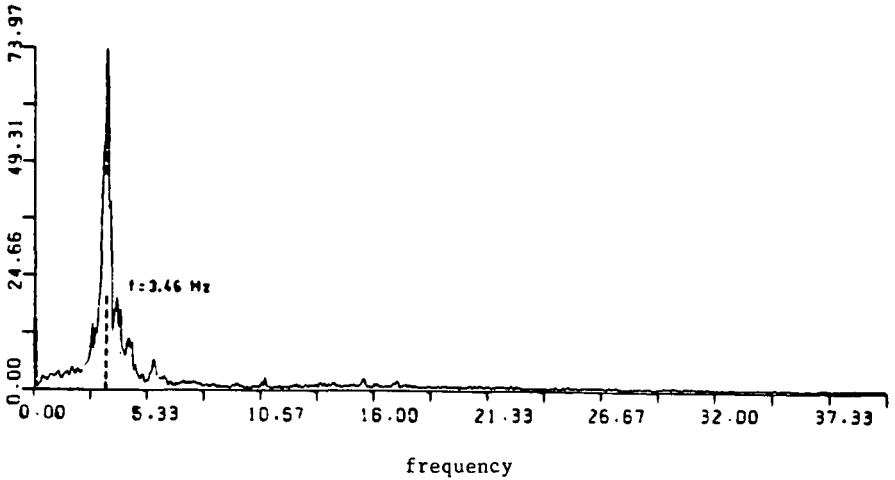

4.6 Amplitude-frequency spectrum for ambient vibrations of a tower

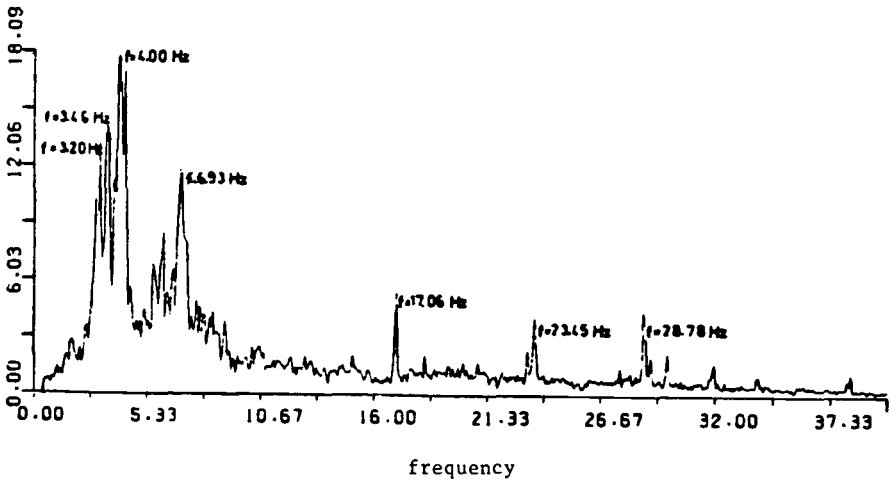

4.7 Amplitude-frequency spectrum for ambient vibrations of a building

Where there is no risk of causing further damage by exciting larger amplitudes, forced vibration tests will be more revealing since they alone also permit the determination of damping ratios.

4.4 Estimation of seismic hazard

For important structures or groups of structures, seismic hazard (in terms

of intensities of ground shaking or peak ground accelerations with given probabilities of recurrence) is best assessed for the site by a seismologist on the basis of past seismic activity, underlying geology, and local soil types. National codes also specify design intensities. These can be used as a check, or independently if more detailed investigation is thought to be unwarranted.

4.5 Analysis of structural response

Analyses of structural response will be required at various stages. Initially the structure as it exists must be analysed to determine its safety and whether any strengthening is required. Subsequently it must be re-analysed, virtually as a new structure, taking into account proposals for strengthening. The methods to be adopted will be similar throughout, though different safety coefficients may be desirable in relation to the existing structure and to new work added to strengthen it.

However extensive the investigations of the existing structure have been, not enough will be known of its materials, past history, and present condition (including existing stress levels) to justify a precise non-linear dynamic analysis, even if this were computationally and economically feasible. The present considered opinion is that with a single exception, only the simplest types of static analysis can be recommended. That exception is the tall slender type of structure best represented in the Balkans by the minaret, for which a linear dynamic analysis is recommended.

For a few structural forms and types of response - notably the response of arches and vaults to vertical accelerations which lead to variations in the horizontal thrusts - exploratory dynamic analyses seem desirable to gain more understanding. But the present need here is for a limited programme of research. Dynamic analysis cannot be recommended for assessments of safety or re-design.

In what follows, methods of static analysis will be considered first, then dynamic methods, with a final discussion of safety coefficients and load combinations.

4.6 Static analysis

In a static analysis the seismic loading is obtained directly from the National code or the independently assessed seismic hazard. The basic ground acceleration (or seismic coefficient) is adjusted as necessary to give a total base shear. This shear is then distributed over the height in accordance with an assumed mode of response. Further analysis may be performed in terms of either elastic stresses or ultimate strengths.

4.6.1 Seismic loading

National codes usually give a period-related horizontal seismic coefficient which either varies according to local soil type or is adjusted for this by a separate coefficient. The basic coefficient is further adjusted by other coefficients to give the proportion of the total weight of the structure that is to be taken as the total base shear. These other coefficients recognise the different levels of safety desirable for different classes of structure and the different capacities of different materials and types of construction to absorb energy and undergo post-elastic deformation without collapse.

The total base shear is then distributed over the height in a prescribed manner. Shears are computed separately for the two main directions and are considered to act independently, but torsions that may arise from eccentricities of centres of mass in relation to centres of rigidity are taken into account.

Most codes make no provision for the effects of vertical ground accelerations on the structure as a whole, on the assumption that most modern structures have an ample margin of strength to resist these effects without special provision. Vertical loads are, however, specified on wide-spanning elements. All codes make further provisions for increased loading on elements that project from the main structure - either vertically like parapets and battlements or horizontally like balconies.

Underlying these provisions is the general objective of ensuring a fairly uniform level of safety in structures of the kinds for which the code has been chiefly formulated. These are structures of regular geometric form and normal height-to-width ratios, with ductile moment-resisting frames. Structures of other types are, as far as possible, brought within the scope of the code by means of some of the coefficients and, for instance, by alternative provisions for distributing the total base shear over the height.

Thus some historical monuments and old buildings within historical urban nuclei can be validly analysed on the basis of the loadings specified, provided that the coefficients are suitably chosen. For others a more fundamental approach is desirable.

Where national codes are used, the following recommendations are made:

- natural periods of vibration may be measured as suggested in section 4.3.5 or calculated for a simplified model of the structure by the Rayleigh method. Most masonry structures (excepting chiefly tall slender walls and towers) are very stiff however, and have periods towards the lower end of the range. Typical examples are 0.2 to 0.3 sec. for 3 and 4 storey buildings of normal height-to-width ratios; 0.2 to 0.4 sec. for small to medium sized domed and vaulted churches; and 0.42 sec. for the massive piers of the Rotunda in Thessaloniki. Since all codes specify the maximum basic seismic coefficient for any period up to 0.5 sec. or more, it is therefore suggested that the maximum should be adopted for all such structures. Timber structures and tall slender masonry ones are more flexible and may have periods around 1.0 sec., so their periods should be estimated and taken into account.
- available information on damping and ductility is sparse and less directly useful because of the interrelatedness of code provisions and the complexity of the mechanisms of energy absorption and dissipation. The appropriate coefficient or coefficients must be selected in relation to those specified for other materials and types of construction. Damping is likely to be near the middle of the range specified for masonry. Effective ductility is likely to be poor, especially in structures with low gravity compression that have few alternative load paths and are liable to fail by shearing of the supporting walls or piers. The coefficient should be chosen accordingly.
- coefficients related to levels of safety desirable for different classes of structure should be selected in relation to the values specified in the code, taking into account the relative importance of the structure, its possible future uses (and the consequent risks to the public of any

collapse), and the future life that is aimed at.

- the applicability of the procedures for distributing the total base shear over the height depends on the modes of deformation under load. The usual rule assumes that the deformation is effectively that of a uniform shear beam. Measured shapes of the fundamental modes of vibration for the 3 and 4 storey buildings referred to above are of this character (as may be seen in the Figure below), so that for such buildings the normal procedure should be followed.

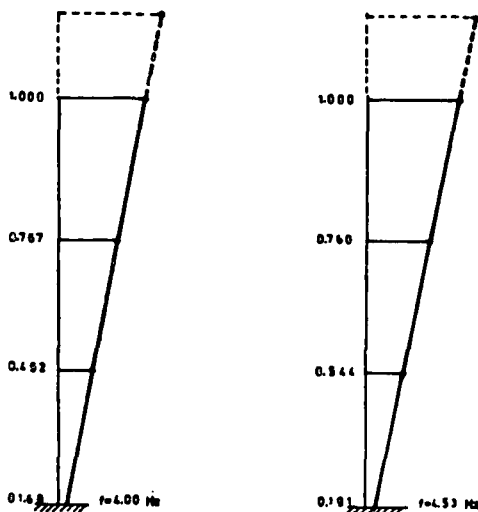

4.8 Fundamental mode shapes for a 4 storey building

For more flexible structures, a larger part of the shear should be considered to act near the top. For more rigid ones, a distribution related simply to the distribution of mass (ie assuming no deformation) might be admissible.

- in the absence of sufficiently clear evidence to the contrary, it is considered that the effect of vertical inertia loads in permitting rocking on the bed joints of masonry walls and piers should be ignored for the present. Vertical inertia loads on wide-spanning arches and beams and similar elements should be considered; also the loads specified as acting on parapets and balconies and similar projections. But the secondary horizontal thrusts resulting from the vertical inertia loads on arched elements should be ignored. For all inertia loads on individual elements, the relevant periods are those of the elements themselves.

Where an independent assessment is made of the seismic hazard, it is suggested that for most stiff masonry structures a value close to the maximum ground acceleration should be used to calculate the total base shear on account of the short natural period, the relatively poor ductility, and the possibility of shear failures in walls and piers. Some reduction in this figure is, however, reasonable if it can be demonstrated from response to past earthquakes that the existing structure has a reserve of strength that cannot

otherwise be accounted for within the overall assumptions of the analysis.

4.6.2 Linear elastic analysis

Any calculation of structural behaviour calls for an analytical model of the structure, and the validity of the predictions made will usually depend more on the skill of the analyst on choosing a valid model than on the choice of calculation method. Often it will be impracticable to analyse the whole structure. The validity of the model will then depend partly on the way in which the boundary conditions are represented - and this includes the representation of boundary conditions at the foundation.

A statically determinate model will be easier to analyse, and does not call for assumptions about the elastic properties of the materials as does a statically indeterminate model. Statically determinate models include shell models for domes, and articulated linear models (or thrust-line models) for some framed and arched structures. Where it can be seen by inspection that the existing structure (or part of it) is effectively articulated so as to make it statically determinate, such a model is clearly admissible and preferable to any other - although analysis of it will yield directly only the forces on given cross sections and not the stress distributions over them. Another obvious application is to the calculation of the tension needed in a peripheral tie at the base of a dome to restrain bursting and give only vertical reactions at the supports.

Where it is desired to explore the stress distribution in more detail - through the thickness of a dome or a supporting wall or pier for instance - the finite element model is the most versatile. This typically represents the structure as a plane or spatial mesh composed of as many elements as desired. An example is given in Figure 4.9. These elements are given properties corresponding to the assumed elastic properties of the structure itself, and the closeness of their spacing is varied in accordance with the expected departures from uniformity of stress and the expected locations of critical regions. The results of such an analysis of a plane section of a heavy masonry dome are given in the case study of the Rotunda, Thessaloniki.

Because more is asked of such a model, the difficulties of defining it in a manner that adequately represents the real structure are increased however. In practice, the stress distributions that are obtained ought to be regarded as showing just a possible response, under certain idealised conditions, to the imposed loads. The actual stress distributions are unlikely even to be quite the same for successive applications of the load, and will certainly differ from the calculated ones on account of:

- differences between the assumed and actual stress-strain relationships of the materials (including non-linearity and limited tensile strength).
- errors introduced by the finite-element modelling of the real continuous structure.
- errors introduced by the actual non-homogeneity and any local discontinuities (cracks).
- most important of all, perhaps, the impracticability of subjecting the model to the unknown and highly complex past loading of the real structure, both during its construction and afterwards.

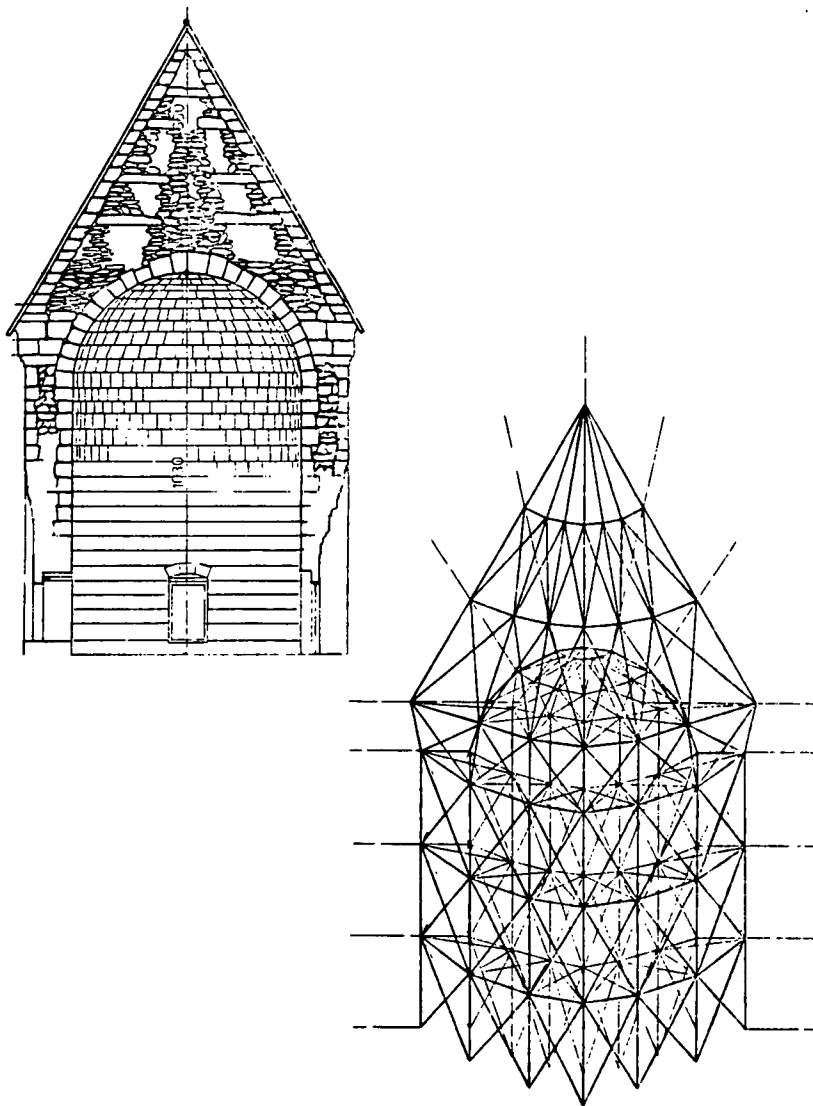

4.9 Hasan Padisah Tomb, Bitlis-Ahlat
cross section and finite-element model

4.6.3 Ultimate strength analysis

Ultimate strengths can be calculated more confidently and reliably. They are also more directly relevant to safety, which should be the chief structural criterion for a historical monument rather than serviceability. It is therefore suggested that analysis should be directed primarily towards their calculation.

It must, however, be remembered that a particular collapse mechanism will, in itself, give only an upper bound for the true ultimate strength. Lower bounds are less easy to calculate, for reasons similar to those just given above. It is therefore important to consider all possible modes of failure and to ensure that none is missed in the analytical model - especially none that involves a shear failure.

For one common type of structure - the old building with masonry walls in an urban nucleus - past earthquake damage shows that the predominant mode of failure is a shear failure of the walls, provided that these are adequately tied together by the floors (or by cross ties in the floors) and that they are not excessively weakened by openings or poorly bonded junctions. If, therefore, any weaknesses of the floors, of internal ties, of junctions between walls, or at openings in them, are made good in the strengthening scheme, ultimate strengths can be calculated by means of a model that simply adds together the shear strengths of all the walls aligned to resist the load in each direction. These shear strengths can be calculated by the semi-empirical formulae derived from tests on similar walls that are given in the manual on design and construction of stone and brick-masonry buildings.

For the type of structure found in many historical monuments - in which masonry piers support arches, vaults, or domes - a more complex model is required. Collapse may occur either by the development of a mechanism in the combined system of supporting and spanning elements, or by failure in shear of a support. The model must allow for both possibilities. Linear or frame models, as shown below, are nevertheless possible, combined with appropriate failure criteria for all the members.

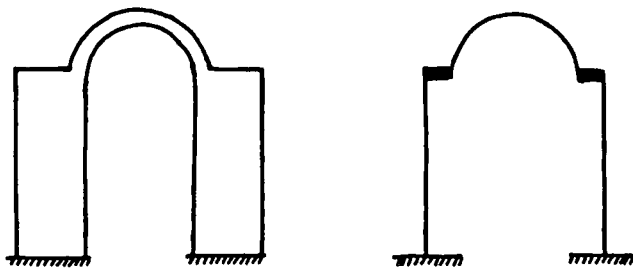

4.10 Arched system and linear frame model

The failure criteria can be represented graphically as interaction envelopes for direct load, bending moment, and shear force, as illustrated in the case studies of the Rotunda, Thessaloniki and the Church of Hagios Andreas, Peristera. If they are so represented, the ultimate strength can be calculated for any pattern and sequence of applied load - gravity load followed by seismic load for instance - by a step-by-step graphical procedure in which the

load is increased until collapse is indicated. This procedure is illustrated in the second of the case studies just referred to. Ideally the failure criteria for the members should be obtained directly from tests on similar members. But it will usually be necessary to obtain them from tests on the materials or on comparable materials, interpreted in the light of available data on the failure strengths of elements.

4.7 Dynamic analysis

The most versatile kind of dynamic analysis follows the structural response to the ground accelerations instant by instant, to give a complete time history. Its chief merit is that - given sufficient computer capacity - it eliminates the need to assume linear elastic behaviour of the materials that arises in any analysis which ignores the sequence of events and calls for the superposition of responses.

Since, for reasons already discussed, it is impossible to take full advantage of this freedom when analysing the types of structure considered here, only response-spectrum modal analysis is worth considering. This derives the seismic loading and its distribution over the height in a manner that gives better recognition to the dynamic characteristics of the structure than do the procedures followed in a static analysis. But it is necessarily a linear analysis, and it is strictly relevant only if safety is assessed in terms of derived stresses.

4.7.1 Seismic loading

A response-spectrum modal analysis is a dynamic one in the sense that it starts with estimations of the periods and shapes of the natural modes of vibration of the structure. Usually it is sufficient to consider only the first three. Periods and mode shapes can be calculated by the Rayleigh method. Seismic shears are then calculated separately for each mode from the acceleration indicated by the response spectrum for its period, and from the modal displacements and the participating masses.

Since the peak shears and moments will not occur simultaneously in all modes, the separate modal responses are usually combined by taking the square root of the sum of the squares. For tall flexible structures, the loading derived in this way is likely to be less than that given by the more arbitrary rules found in codes of practice for deriving equivalent static shears.

4.7.2 Linear elastic analysis

A dynamic analysis of this kind was recommended in section 4.5 only for the slender minaret-like structure, which is easily modelled as a tube. Once the loading has been determined, stresses can be calculated statically, again assuming linear elasticity. If tension is indicated at some sections, a further calculation should be made for no tension.

4.8 Safety coefficients

The results of any analyses must finally be interpreted and decisions made about whether or not the calculated stresses or ultimate strengths are acceptable. Quantitative criteria of acceptability are needed, and the criteria given in codes of practice for new structures are not relevant. Historical structures vary so much that each should really be considered on its own

merits. But some general guidance can be given:

- the chief load combinations to be considered are dead load plus seismic load and - for tall structures on exposed sites - dead load plus wind load. Snow load may also sometimes call for consideration where it can be large in relation to dead load at roof level. User-imposed live load will rarely be significant in relation to dead load.
- dead load is not subject to variation as in a structure that is still to be built, but some factor on it may still be necessary to cover possible shortcomings in the estimates made of it.
- factors to cover possible shortcomings in estimates of seismic loads must be chosen in relation to those specified in codes, bearing in mind the likely relative accuracies of the estimates.
- factors to cover possible errors in the calculation of ultimate loads or stresses should be similarly chosen in relation to those specified in codes. Unless cautious assumptions have been made in the analysis, they may have to be higher because of the greater difficulties of accurate analysis.
- like dead load, unit strengths of the existing materials are not subject to variation as in a structure that is still to be built. Difficulties of determining characteristic strengths and their variation through the structure, coupled with ignorance of the influence of past loading history on the existing stresses, may, however, equal or outweigh the variation that has to be allowed for when designing a new structure.
- before a final choice of coefficients is made, they should be considered together, because it is their combined influence that is important. At this point, the overall objectives should also be taken into account - such as the intended future use of the structure, the resultant likely consequences of future damage, and the life that is aimed at - particularly where these objectives differ significantly from those envisaged by current codes of practice for new construction.

Finally it is important that the calculations should be seen in proper perspective. The structure already exists, and usually it has already been tested extensively by what it has already undergone. Full use should be made of all that is thus demonstrated about its strengths, even if calculation cannot quite explain them. Moreover, no analytical assessment of the kind considered here can guarantee a good structure. The engineer should not rely on it alone, but should give at least as much attention to overall structural form - distributions of mass and stiffness etc. - and to the avoidance of catastrophic modes of failure, whether brittle or due to instability.

5. METHODS OF EMERGENCY INTERVENTION, REPAIR, AND STRENGTHENING

A wide range of methods is described here. But no attempt has been made to cover methods that are not specifically relevant to improving the resistance to a future earthquake or to deal with general maintenance. Just as a possible seismic hazard should be taken into account when a structure is repaired or strengthened primarily for some other reason, so should other hazards and causes of deterioration - such as rising damp or rainwater penetration - be dealt with by appropriate further measures when earthquake damage or a risk of future damage is the primary reason for intervention. The importance of continuous good general maintenance cannot be overemphasised. Much damage could have been averted in the past by better maintenance.

The methods that are described involve different degrees of interference with the existing fabric, and offer different degrees of long-term protection. Some should give protection for a very long time. Others use materials that are known to be less durable, or whose durability is unproven and open to doubt. Choice between alternative methods should be made on the basis of the general principles outlined in sections 2.1.2 and 2.1.3, and in the light of the comments made here.

5.1 Emergency interventions

A structure in need of strengthening usually calls for temporary strutting or shoring to reduce the risk of a worsening of its condition before the final strengthening can be undertaken. An emergency intervention of this kind is particularly necessary when the structure has just been badly damaged by an earthquake, partly because of the likelihood of aftershocks and partly because it may be several years before permanent works are possible. Additional measures may be necessary to protect valuable surface decorations and fixtures. Both these kinds of intervention are considered here. The obvious need to move other valuable contents to a place of safe storage has also been mentioned in the earlier discussion of emergency works in section 2.3.2 and should not be forgotten.

5.1.1 Temporary shoring and strutting, etc.

Struts and shores provide vertical or inclined support to parts of a structure that are in danger of dropping or tilting and overturning. The use of temporary ties should also be considered where walls or piers are tending to tilt away from one another because of weak interconnections, especially if they are being thrust apart by arches, vaults, or domes that span between them.

For struts and shores, timber is often the most readily available material. Its chief drawback is that it creates a fire risk. Good fire precautions are therefore necessary if it is used in a major historical monument, as seen in Figure 5.1. It is also susceptible to significant dimensional changes under prolonged load and with changes in moisture content, as well as to rot and insect attack. Regular inspection is thus another necessity if the strutting or shoring remains in place for a long time.

Steel does not have these drawbacks, but is subject to rusting, and should be protected against this risk in accordance with the type of exposure. With suitable protection, it is generally to be preferred to timber for important structures.

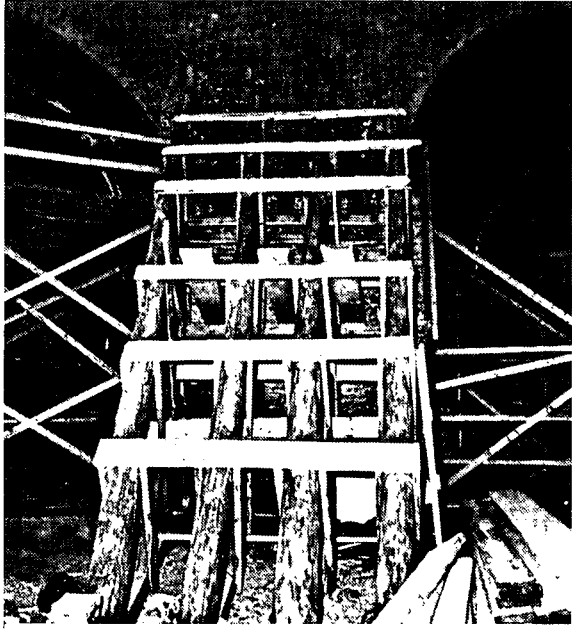

5.1 Timber shores, Rotunda, Thessaloniki

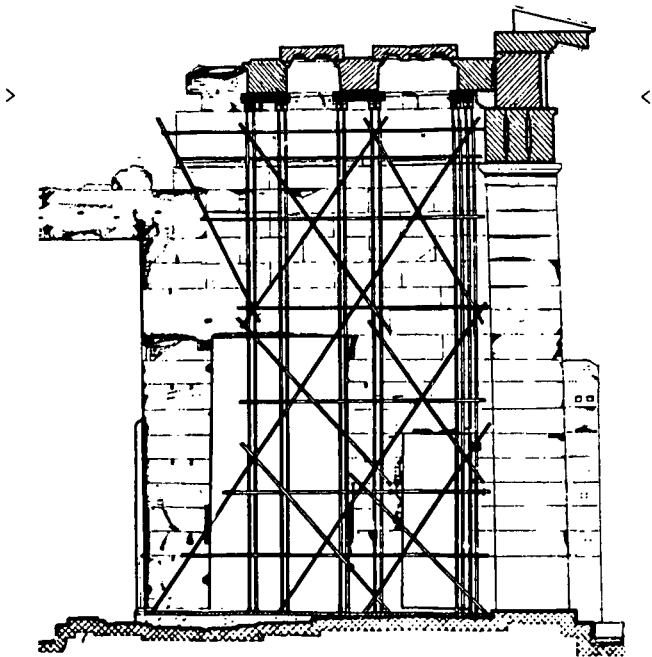

5.2 Shoring of the East Portico, Propylaea, Athens



5.3 Temporary prestressed ties, Rotunda, Thessaloniki



5.4 Temporary ties, Jesuit College, Angra do Heroismo

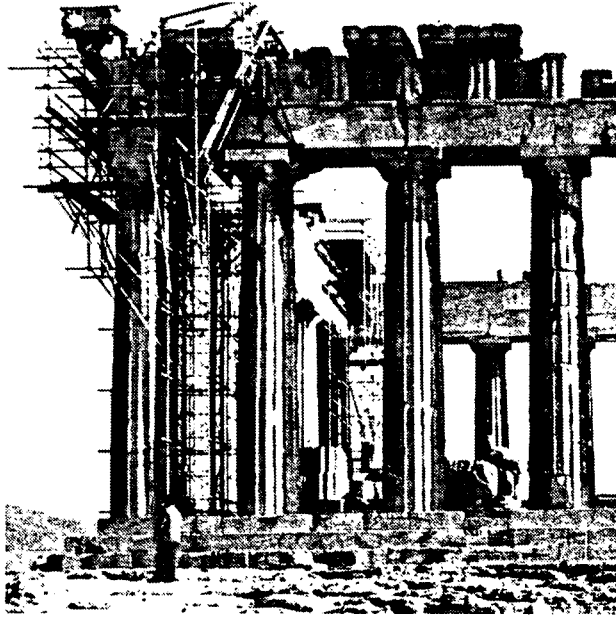

a

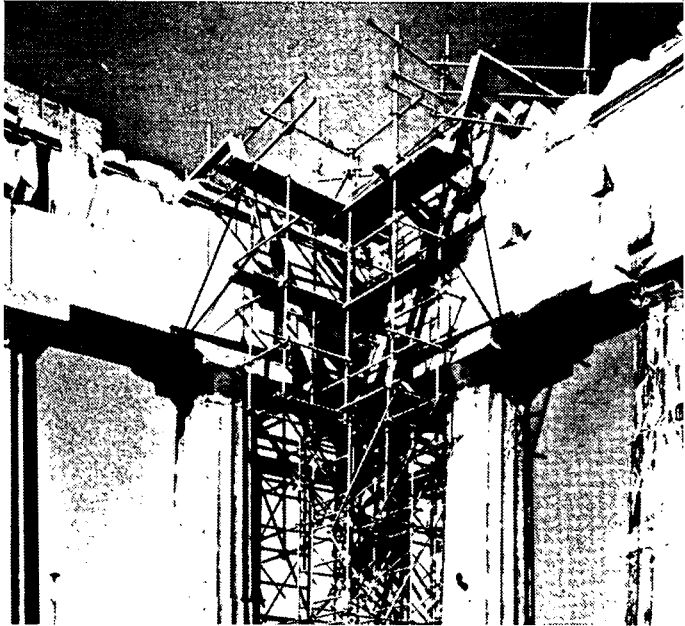

b

5.5 High-level temporary tying, Parthenon, Athens

When designing strutting and shoring, it is important to bear in mind the effects they will have on the dynamic response of the existing structure. In general it will be best to make them act as integral parts of this structure or as distinct new elements - as the raking shores of Figure 5.1 might be regarded. Alternatively, a separate support may be built up from the ground beneath a part of the structure in danger of falling, but without any firm contact. This was the procedure followed on the Acropolis, Athens, to safeguard architraves of the East Portico of the Propylaia, as illustrated in Figure 5.2. Interposed between the soffits of the architraves and the timber cross pieces (shown in solid black) at the top of the tubular steel shoring tower was 5 mm of soft packing to allow relative movement unless the architraves did start to fall.

Temporary ties must be made from steel rods, cables, or prestressing tendons, and should be suitably protected against rust. Care should be taken in locating them and in providing adequate anchorages where they are not continuous, and suitable packings where required, to distribute the tie forces into the existing structure.

To contain the thrusts of arches and vaults, ties should preferably be placed near the springing levels. To contain those of a dome, the tie should encircle it near the springing level, as do the ties seen in Figure 5.3. To provide temporary support to the walls of a building that have cracked apart and are leaning outwards, ties should similarly encircle at each floor level the walls at risk, as seen in Figure 5.4. A further and related use is illustrated in Figure 5.5. The epistyles had separated in the corner above the column at the left of the upper view and in the one seen through the second intercolumniation after the 1981 earthquake. They were tied together by continuous ties looped around the abacus of the second column to each side and held at suitable heights by being passed through the inclined frames that encircle the epistyles.

All ties should be prestressed sufficiently, at least, to place them in reasonable tension without further undesirable movement of the existing structure. This may call both for calculation of the desirable prestress and for continued monitoring of it - either directly or indirectly. Indirect monitoring may be possible either by accurate measurements of spans or by measurements of the widths of cracks or separations associated with the movements that have already occurred. This is referred to further in the case study of the Rotunda, Thessaloniki.

In designing all temporary supports, the engineer should try to look ahead to the final works of repair and strengthening and to arrange the supports so that they do not interfere with these final works or the access that will be required to them. Sometimes the supports - particularly ties - can be arranged so that they can be used during the final works to apply controlled forces or displacements thereby, for instance, eliminating part of an undesirable outward inclination of a wall. The ties seen in Figure 5.4 were used in this way. It need hardly be added that care should always be taken to avoid inflicting further damage when installing any temporary works.

5.1.2 Safeguarding of surface decorations

The types of decoration most likely to call for emergency protection are frescoes and mosaics. These are executed on plaster beds on the surfaces of walls, piers, vaults, or domes. Movements of these structural elements may loosen the plaster or cause cracks in it, and both loosening and cracking may occur without an earthquake. Earthquake shaking is likely, however, to

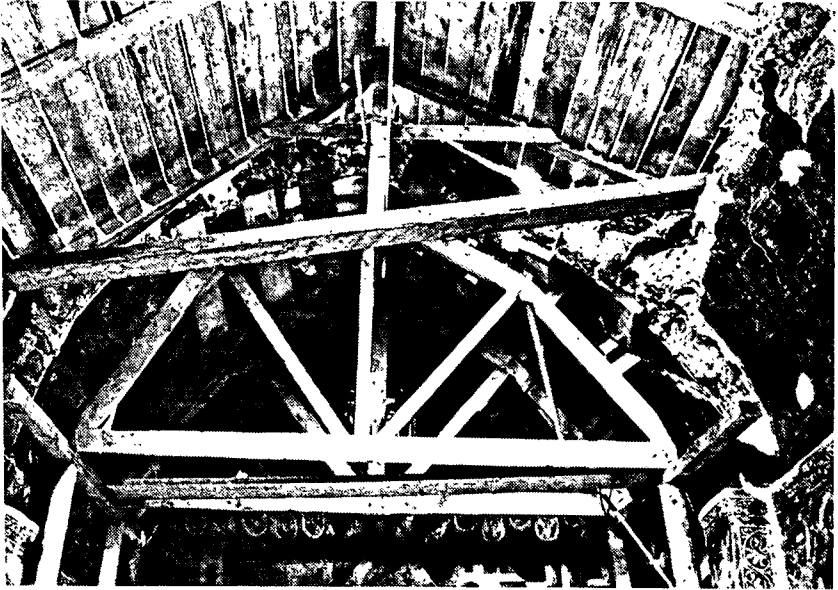

5.6 Temporary weather protection, Sveti Nikola, Gradiste Monastery



5.7 Preparation for removal of mosaics, Rotunda, Thessaloniki

worsen whatever has already occurred and to create a real risk of part of the decoration falling. Cracking of structural elements and any local collapses will create risks of further damage by leaking water or direct exposure to the weather.

The first priority should be protection against the weather wherever this is necessary. Figure 5.6 shows temporary roofing to protect frescoes on the walls and surviving vault surface after a partial collapse of the vault in the 1979 Montenegro earthquake.

Further protection should be undertaken in close consultation with the appropriate experts. Often a choice will present itself between providing temporary support to retain the decoration in place until permanent consolidation is possible and the alternative of removing it before it falls.

Removal and subsequent reinstatement will often be the best choice for easy removable wooden panelling, because it is unlikely to suffer much damage if it is removed with care and subsequent structural work will be facilitated. The removal of frescoes and mosaics is, however, to be avoided if at all possible, since cutting into manageable sections is essential and significant loss is almost inevitable. Where it is to be undertaken, it is necessary first to make a precise record of the decoration, then to glue fabric to the surface and mark this out to indicate the lines for cutting and the positions for reinstatement as shown in Figure 5.7. This, and the subsequent removal and reinstatement, are tasks for specialists.

It is better to retain the decoration in place if possible. This calls for a system of temporary support which will give distributed and slightly flexible support over the whole surface and which will move with any subsequent movements of the structure behind but will not move independently of this. For support at high level, for instance, the base of the support should also be at a high level and should be as rigid as possible if any considerable span is called for.

In the example illustrated in Figure 5.8, the mosaic (with its setting bed) was found to have separated from the dome (whose brickwork is exposed by a partial loss of the mosaic at the right hand side of the upper view) over most of the surface. Pending a decision on final treatment, it was supported as shown. A rigid trussed platform was erected at the springing level as seen in the lower view. Above this, several lighter boarded platforms were erected at about 2 m intervals, carried on the first by tubular steel struts. Then, from these, raking adjustable steel props were used to press slightly flexible plywood panels gently against the curved surface of the mosaic as seen in the upper view, leaving only narrow bands of mosaic unsupported between the panels. For further temporary protection, nails with circular spreader plates were driven at intervals through the mosaic into the brickwork of the dome. In a situation like this - with the springing of the dome about 20 m above the ground - a support carried up from floor level would have been too flexible, and would have tended to move differently from the stiffer masonry supporting the dome in the event of another earthquake.

5.1.3 Partial demolition

This is mentioned only for completeness. In a badly damaged structure, some deliberate further demolition may be unavoidable to permit further emergency inspection and intervention to proceed with safety. But it should be undertaken on a historical monument only if, after a careful initial structural appraisal, there is no reasonable alternative. And it should be undertaken

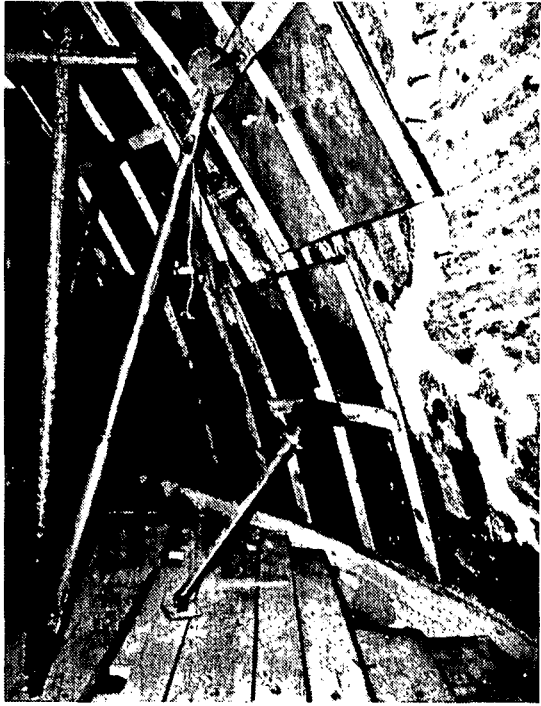

a

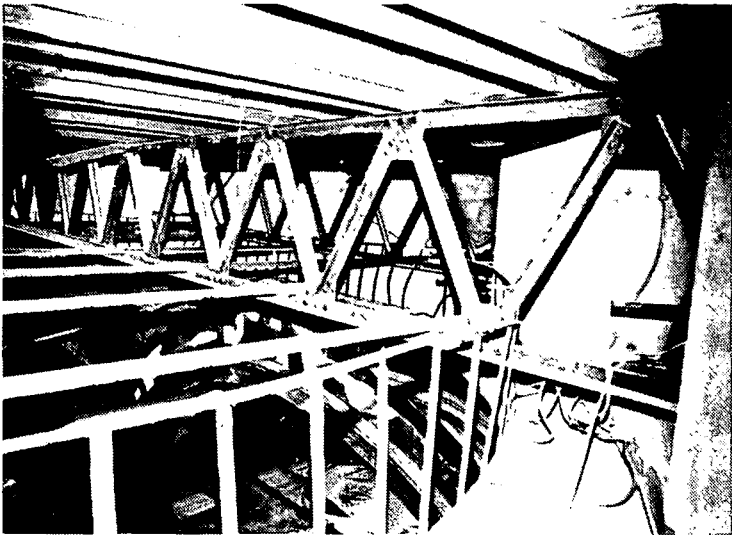

b

5.8 Temporary support for mosaics, Hagia Sophia, Thessaloniki

in such a way as to create the minimum hazard to the rest of the structure

5.2 Partial dismantling for repair and reconstruction

Partial dismantling for repair and reconstruction must be distinguished from the partial demolition referred to above. It is not an emergency intervention to forestall a possible collapse, but a carefully planned and executed operation to permit repairs that cannot otherwise be undertaken or the incorporation of new strengthening elements in places that would not otherwise be accessible. To the extent that it involves interference with the authentic original structure, it is undesirable - just how undesirable being dependent on the importance of that part of the structure that is disturbed and on how far re-erection is possible without change of character.

The only historical monuments which do permit dismantling and re-erection with very little loss of authenticity are those constructed wholly or partly of timber and/or good ashlar. Several classical temples, theatres, etc., have already been re-erected in part, so there can be little objection to dismantling these afresh if there is good reason for it and no damage is inflicted in the process. This has recently been the situation on the Acropolis in Athens after the restorations undertaken earlier in this century, and was one justification for the dismantling described in the case study of the Erechtheion.

The requirement that no damage should be inflicted on the blocks of stone or other members that are taken apart calls for careful handling and may necessitate the construction of special lifting tackle and other related provisions as illustrated in Figure 5.9 and described in the case study just referred to. The other chief requirements are for careful numbering of all units, full recording of the whole procedure, and proper provision for the safe temporary storage of the units.

5.3 Materials for repair and strengthening

Among the construction materials available today are many - such as high strength steels, stainless steels, epoxy resins, and modern cements - which have obvious attractions for the engineer responsible for repairing or strengthening an old structure. Indeed Article 10 of the Venice Charter authorises their use 'where traditional techniques prove inadequate' and where they are adequately proven for the particular use. But these conditions are important and, as was pointed out in section 2.1.3, very limiting in relation to historical monuments and other structures which must be considered in a similar manner because of their contribution to a group.

Unless an intervention is designed to permit an easy further intervention in the future - unless, in other words, it is easily 'reversible' - both chemical and physical compatibility with the existing materials are called for over a long period, and strengths and other essential properties must also be maintained over this long period.

These requirements of long-term durability and compatibility in the case of irreversible interventions are what chiefly distinguish the choice of materials for the works described in this manual from the choice for the otherwise similar works on structures of no special historical importance that are described in the companion manual on repair and strengthening of reinforced concrete, stone and brick masonry buildings. The principal materials available

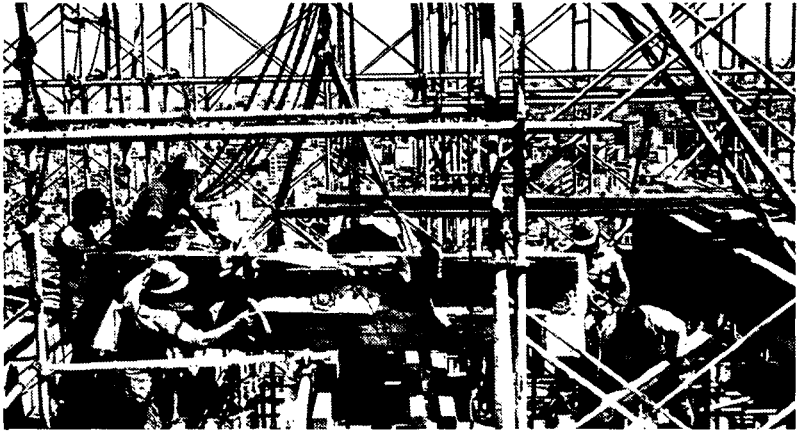

a

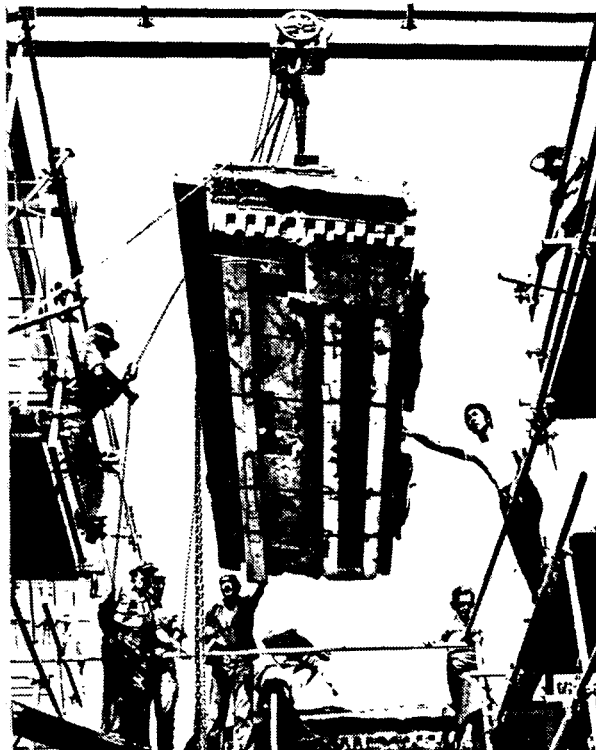

b

5.9 Lifting and traversing arrangements, Erechtheion, Athens

are reviewed below from this point of view without any attempt at a detailed coverage.

5.3.1 Non-metallic materials

The ideal materials for irreversible interventions are brick, stone, mortar, and concrete, each of similar character to those used in the original construction. They can neither corrode nor rot, and no problems of chemical or physical incompatibility can arise. Only if the original materials have weathered poorly or proved deficient in strength may some small change be desirable. The chief problem is likely to be that of obtaining a good match - visually as well as in other respects if the new material will be exposed to view.

In the selection of natural stones, expert advice is recommended. For other materials a programme of testing may be necessary to match the most important properties of strength, modulus of elasticity, permeability (chiefly for materials to be used in external elements of the structure), thermal expansion, moisture movement, and chemical reaction. In the absence of a good match, there will be risks of separation of the new material from the old, or damage to the adjacent old material if this is weaker or (in situations where there are continual moisture movements) more permeable. The commonest mistake is to repair an external wall with new work which is too stiff and too impermeable in relation to the existing construction. In the examples illustrated in Figures 5.10 and 5.11, breaks in a defence wall and in its parapet have been made good with stronger new masonry which has cracked the old masonry seen below and led to a partial collapse in the second instance.



5.10 Cracking of a wall after repair, Castle of Heraklion



a

b

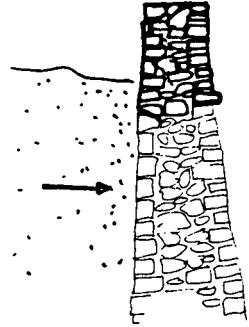

c

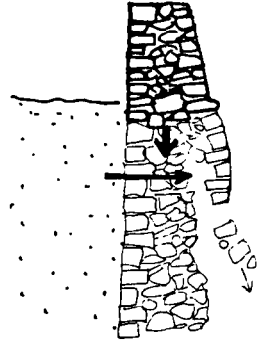

d



A need for testing is most likely to arise when choosing grouts for injecting into cracks or filling voids in walls. Traditional mortars were mixed from hydrated lime, sand, and frequently either natural pozzolanic ash or powdered brick. Modern grouts usually substitute cement for the lime or the mixture of lime and pozzolana or brick dust, and they are consequently usually stiffer and stronger. This is undesirable if the grout will replace the weaker old mortar in parts only of the masonry, since it will lead to the situation that has just been referred to. It is best to restrict the use of such grouts to situations in which the grout will permeate the whole of the bearing structure in a uniform manner. Tests to select suitable grouts for local repair and strengthening of the Byzantine monuments of Thessaloniki are described in the case study of the Rotunda.

The recent development of organic resins with a wide range of strengths, elasticities, etc., has presented a further choice, particularly since these resins do not shrink on drying, penetrate well, and have excellent bond properties. It is possible to choose either a pure resin or a resin mixed with a fine aggregate to give, apparently, all that is required for any particular application. But the high cost is not the only drawback. There is, as yet, no long-term proof of their suitability, so that it would be risky to use them for such an irreversible intervention as grouting. At most, they may, perhaps, be admissible for grouting fine cracks in otherwise sound material.

The use of modern cement concretes (including Shotcrete and Gunitite) is best restricted to the construction of essentially new elements that are capable of working in harmony with the existing structure. Further references and some cautions will be found in later sections.

Timber has many excellent characteristics, and there are long traditions of valuable use in enhancing structural performance in earthquakes, some of which were referred to in chapter 3. Its drawbacks are the fire risk that it creates in some applications and the susceptibility of some species in some situations to fungal and insect attack. If it is badly damaged or decayed, or if a whole timber floor or roof has proved to be structurally inadequate, the possibility of substituting steel or reinforced concrete will obviously arise. This is discussed further in section 5.7.5. For a historical monument, this change in structural character is, however, undesirable in itself, and it can lead to other problems. Repair or replacement with timber is preferable. But attention must be paid to choice of species, and to seasoning and moisture content, and treatment with a suitable preservative may be desirable.

5.3.2 Metallic materials

Where high tensile strength is required, steel must usually be employed in spite of its newness and liability to corrosion: alternatives would be too expensive. Many different steels are available, varying in cost, corrosion resistance (stainless steels), and strength. Also many protective treatments of varying value are available for steels that are not corrosion resistant and will otherwise be vulnerable. Choice between steels and treatments must be made, if necessary with specialist advice, on the basis of the most desirable properties and the cost - the latter in relation to the age and importance of the monument or other structure.

There are instances, however, where no risk of future corrosion can be tolerated. The serious damage caused in recent years by the rusting of iron cramps and other reinforcements embedded in the marble masonry of the monuments on the Athens Acropolis led, for instance, to the choice of titanium

for the new cramps and dowels used in the repair of damaged blocks and in the rebuilding of the walls of the Erechtheion, as described in the case study.

5.4 Local repairs

By local repair is meant no more than the making good of local damage. Depending on the manner in which the repair is executed and the nature of the damage, there may or may not be a local strengthening or restoration of strength. But even local repairs which do not directly add to strength will often be a necessary part of an overall strengthening scheme. They should also halt, or assist in halting, damage of a non-seismic origin, and may make a building that has been only lightly damaged habitable again.

5.4.1 Repair of cracks and other local damage to masonry

The most frequent need is for the repair of cracks in masonry walls. Similar repairs may be necessary in other masonry elements - for instance the repair of radial cracks around the base of a dome or of cracks in a vault.

Suitable techniques vary according to the type of masonry, the width of the crack, its location, and (closely related to the location) the desirability of re-establishing a structural interconnection in addition to filling the gap. The re-establishing of a structural interconnection capable of transmitting appreciable tension calls, however, for some kind of reinforcement, and this comes more under the heading of strengthening. As part of the overall strengthening scheme, it may also be decided to reverse some of the movement that was associated with the crack. This also is discussed later. But it does have an implication for repair, since it means that a narrower crack will remain to be filled.

The repair techniques suitable for historical monuments are grouting and the bonding-in of new bricks or blocks of stone across the crack after cutting out some of those to each side to provide a good key.

For fine cracks, and for most other cracks where there is a considerable thickness of masonry, grouting is the only feasible method unless extensive prior cutting is undertaken. It is also the obvious technique to use if it is necessary, for the purpose of overall strengthening, to grout the whole core of the masonry. Grouting is discussed further in section 5.6.1.

Partly because of the need for some prior cutting, the bonding-in of new bricks or blocks of stone across the crack involves more labour. It also calls for the selection (and perhaps for the special manufacture) of suitable matching bricks or blocks and for a matching mortar. For thin masonry it can be done throughout the thickness. For thicker masonry it can be limited to the faces, the crack behind being grouted after some initial filling if the width calls for this. Some overall gain of strength will result from a bonded repair if the mortar is well rammed between the new 'stitching' bricks or blocks and the prepared masonry key to each side. In principle, this technique is the best one where a crack runs through a bonded return (or junction of two walls at an angle), although it is also more difficult to execute well in this situation. Figure 5.12 shows the preparatory cutting at one side of a wide crack at the base of a double-shell brick masonry dome.

A further technique for vertical cracks, in which reinforced concrete columns are cast into irregular chases formed by cutting as just described and as



5.12 Crack repair, Mausoleum of Oljeitu, Sultaniya, Iran

illustrated above, is admissible chiefly for some buildings of less individual importance in urban nuclei. See the manual on repair and strengthening of reinforced concrete, stone and brick masonry buildings for this.

The other repair that may be necessary is the rebuilding of parts of the facings of walls where these have fallen bodily (usually exposing a rubble fill in the core) or have been slowly eroded (usually near ground level as a result partly of recurrent dampness) or robbed for re-use of the stone or brick. Damage of these kinds should be repaired by bonding-in new masonry of matching character after a limited cleaning of the surface of the break and after any necessary consolidation of the interior. If a repair of this kind is to restore the wall to its initial structural condition in resisting a future earthquake, good bonding-in of the new work and good matching of the materials in terms of structural properties are essential. The warning in section 5.3.1 against the use of materials (especially mortar) that are too stiff or impermeable should be headed here.

Special consideration must be given to walls that are constructed throughout of finely dressed ashlar. Here, dismantling, followed by the repair of damaged blocks and subsequent rebuilding as described in the case study of the Erechtheion, may be justified.

5.4.2 Repair of individual blocks of stone

The repair of individual blocks of stone will be justified only where an adequate replacement block would be more costly, or where no replacement would be acceptable except for reasons of absolute necessity. The former situation will arise chiefly where the damage is slight and superficial, and the latter where there would be an unacceptable loss of authenticity if the original block were replaced. These situations are encountered most frequently when dealing with major Classical monuments constructed from the fifth century BC through to the Hellenistic period. In structures of later date, they are likely to arise only for blocks whose decoration makes a major contribution to the architecture or is of considerable intrinsic importance.

Repair may, or may not, involve a necessary strengthening. If the block serves as a lintel and is cracked through its depth, it will either have to be reinforced longitudinally or suspended from above. If it is a column drum

from which there has been slight surface spalling, there may still be sufficient cross section left to meet all structural needs, and the repair need be little more than cosmetic.

In this latter case, it has been common in the past to make good the loss in cast stone or concrete. This cannot be regarded as a permanent repair, though no irremediable harm will have been done if the patch falls away, provided that there was no prior cutting of the original damaged surface to give a good key. Making good the loss with a matching stone will be better if this is cut to a close fit and can be adequately secured. In spite of limited experience, this seems to be a possible role for epoxy resins, since again no irremediable harm will have been done if adhesion later fails.

The choice is less free where the repair must later carry significant load, and where, usually, it is necessary to make good a larger loss or to join two separated pieces of comparable size. The usual procedure in the past is not a good model here. Losses have been made good with new stone, but fitting has been facilitated by first cutting back the original broken block to form a regularly shaped key as seen in Figure 5.13. This is highly undesirable because it precludes the later identification and fitting of the lost piece of the original block. New completion pieces should be cut to fit the original fracture surface as shown in Figure 5.14. This is done by first making a plaster cast and then copying this precisely. A second mistake in the past was to attach a completion piece or to join two separated pieces by means of iron or steel cramps, dowels, or other reinforcements which it proved impossible to protect adequately against corrosion. The resulting new fractures have already been referred to in section 5.3.2. It is essential to use only cramps, dowels, and other reinforcements made of a metal that will not corrode.

Considerable thought was given to the procedures desirable for this type of repair when planning the restoration of the Erechtheion. When it was necessary to connect two separated pieces, for instance, holes parallel to the longitudinal axis were first drilled in corresponding locations through both pieces. Titanium bars (threaded to improve bond) were then inserted for half their lengths through one piece as seen in Figure 5.15a, and grouted in place. The holes in the second piece were then also grouted and the face of the break was covered with cement mortar prior to bringing the two pieces together and inserting the protruding bars into the holes of the second as seen in Figure 5.15b. For a member required to resist bending stress, the reinforcing bars were selected to resist the full tension on the tension side and a nominal compression on the compression side. A prestressing force was also sometimes applied. A similar reinforcement technique was also applied to some cracked members still in situ with only one end accessible. Some slight cutting was then necessary at right angles to the longitudinal axis to permit the anchorage of the reinforcement near the inaccessible end.

5.4.3 Repair of timber members

It will usually be easier to substitute new for old when repairing a timber truss or frame or timber claddings, unless the damaged member or members are large ones. Whatever the size, repair rather than replacement will be preferable if the damaged member is, in itself, of architectural, artistic, or historical importance.

Repair of damaged members should, where possible, be carried out by inserting new timber of the same kind with the minimum of cutting into the original timber to permit making a good joint. One of the traditional scarf joints,

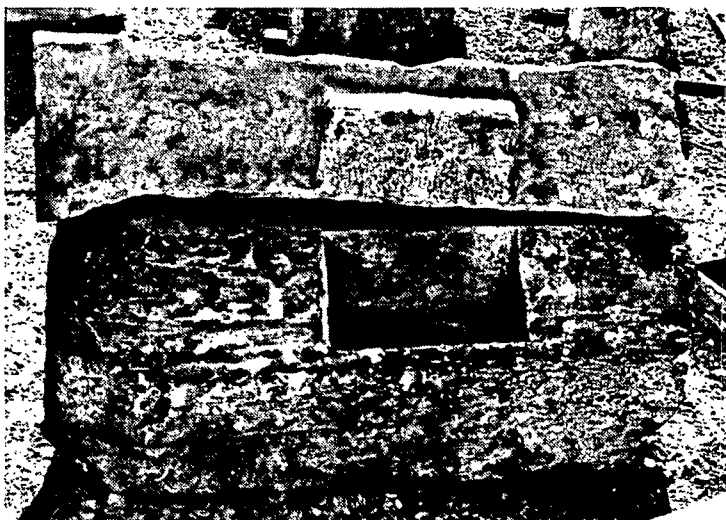

5.13 Damaged block and completion piece, Erechtheion, Athens
1902-1907 restoration

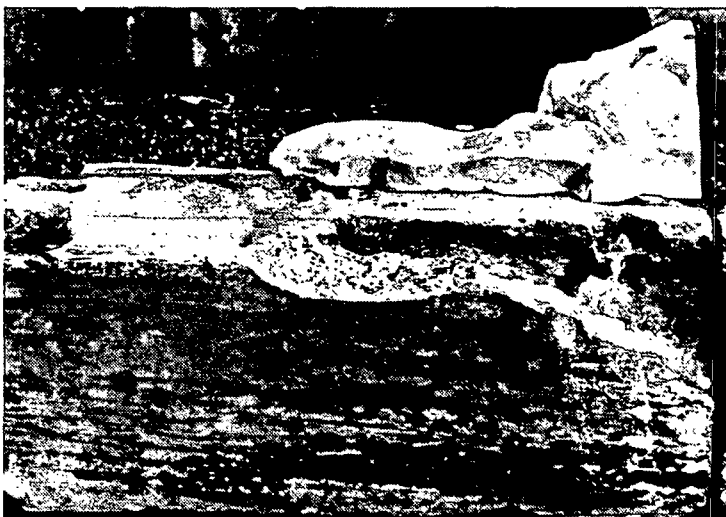

5.14 Damaged block and completion piece, Erechtheion, Athens
current restoration



a

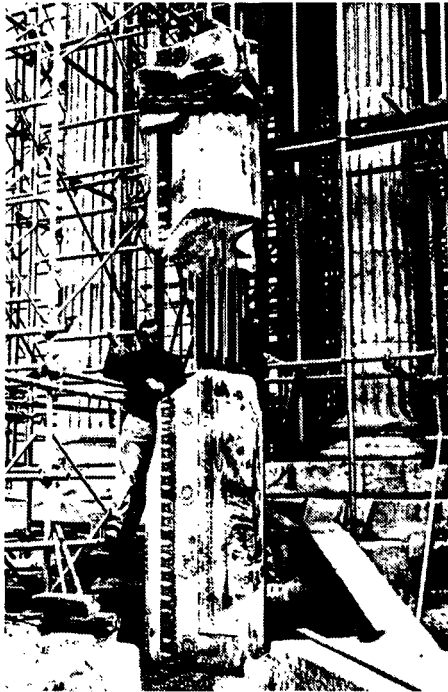

b

5.15 Reinforcement and connection of separated pieces, Erechtheion, Athens

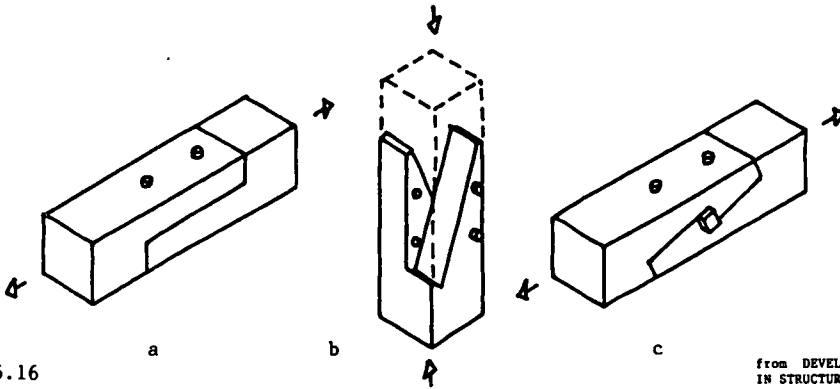

as illustrated above, will usually be appropriate, reinforced as necessary by metal plates or straps (provided that these are protected against corrosion and accessible for future inspection). Joints a and c are suitable for members subject to tension, and the scissor scarf, b, for members subject to compression. A more efficient modern alternative is illustrated below.

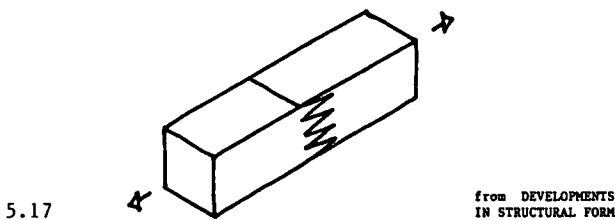

This relies on a good synthetic glue and, when new and well made using a special tool for cutting the fingers, is capable of developing the full tensile strengths of the separate pieces. Its drawback for use in a historical structure is the possible doubt about the durability of the glue in the particular environment of use.

A further possibility, where a member has failed at an end connection (as not infrequently happens at the feet of rafters, where they are housed in the ends of horizontal ties), is to remake the joint with metal straps, provided again that these are protected and will remain accessible. But it is always preferable in a historical structure to repair or replace the damaged member or members and retain the original form.

5.4.4 Other aspects of repair

Although structural repair is the primary concern of this manual, the reader is again reminded that other types of damage and other existing weaknesses should also receive attention.

Even from the structural point of view, it is particularly important that other repairs should be undertaken wherever they are needed in order to prevent water penetration, to control upward movement of ground water, and to eliminate major fire hazards where this can be done without serious loss to the essential architectural or historical character.

5.5 Re-erection of dismantled or fallen masonry or timber

Re-erection of dismantled or fallen masonry or timber might be regarded as a general repair. The intention, with a historical monument, is to restore the structure (or as much of it as remains) as closely as possible to its original form. But the opportunity exists for introducing some strengthening. This opportunity should not be ignored.

The possibilities will probably include some of those described below in sections 5.6 and 5.7, to which the reader is referred. The other main possibility is that of improving the interconnection between individual blocks of stone or members of a timber frame. If this is attempted, it is preferable to keep to the materials and structural details used in the original construction unless there is good reason to depart from them. In this connection see the note on columns constructed from superimposed drums in section 5.6.3, and the earlier discussions of materials.

An example is described in the case study of the Erechtheion.

5.6 Local strengthening

The distinction between local and overall strengthening is largely one of convenience. Techniques which are applied locally and which directly increase the strength of the element to which they are applied - as when a masonry wall is grouted and reinforced - are described here. Techniques which are less local in their application or serve chiefly to increase the overall strength - as when ties are introduced to connect elements together - are described in section 5.7. But both should be considered in terms of their contribution to the overall seismic response of the structure.

The strengthening of free-standing columns and minaret-like structures is, however, included in this section because these are (or are in effect) single elements.

5.6.1 Strengthening of walls and piers by grouting and reinforcement

The use of grouting to fill cracks in masonry and to consolidate loose or weak rubble cores has already been referred to.

No gain in overall strength should be expected from it alone. Strength under triaxial compression will certainly be increased. But little tensile strength will be developed across the cracks and other voids that have been filled. Thus, for a useful increase in strength, tensile reinforcement or other confinement is also required. The grouting procedure will be considered first; then methods of reinforcement.

Typical mechanical grouting equipment consists of a pump, mixing tanks, hoses, and nozzles, as seen in Figure 5.18. Two mixing tanks are used alternately to prepare the mix and feed the pump, in order to permit continuous operation. In the equipment illustrated, the mixers have a volume of approximately 230 litres, and mixing lasts one minute. The piston pump is capable of developing exit pressures of 5 to 8 atmospheres, depending on the length of hose. It can pump a mortar mix with aggregate particles up to 1 mm in size. The high-pressure hoses are 40 mm in diameter and from 30 to 200 m in length.

Nozzles are illustrated in Figure 5.19. The 5 mm nozzle seen at a is used for cracks up to 10 mm wide. The 10 mm nozzle at b is used for wider cracks.

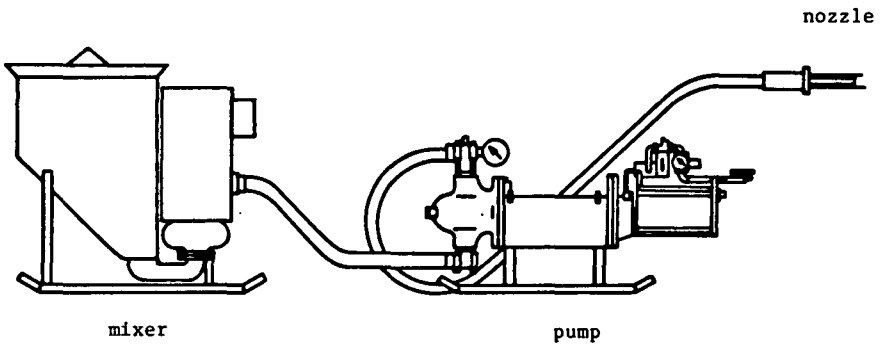

5.18 Mechanical grouting equipment

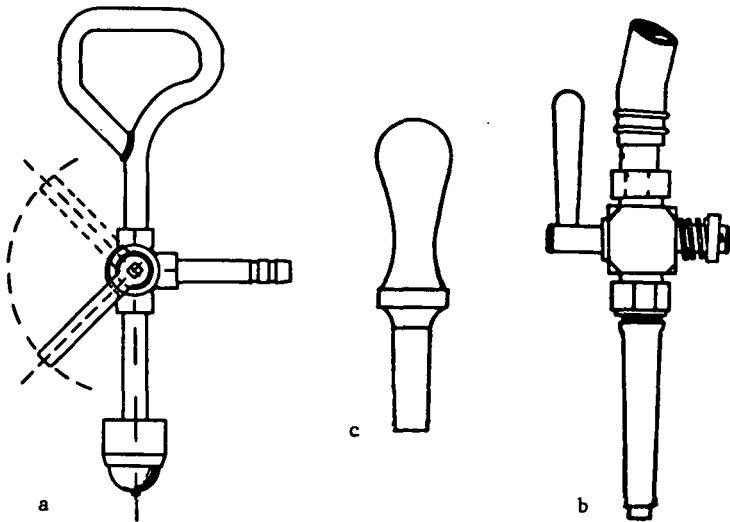

5.19 Nozzles for grouting and tapered plug

Simpler equipment can also be used, with either a hand pump or gravity feed. It is safer to use because it reduces or eliminates the risk of an excessive build up of pressure if the flow of grout is suddenly blocked. There is some risk with any pump, but the hand pump has the advantage that the operator will immediately feel the pressure rise and react to it. If a large build up does occur, it can blow out stones from a wall and do other damage. Very good communication is therefore required between the operator of a mechanical pump and those directly observing and controlling the grouting.

Before injection of grout commences, several preliminary steps are needed:

- since some spillage of grout is inevitable, all surfaces that might be damaged by it should be protected. As a further safeguard, provision should be made for the immediate cleaning of any important surfaces on which spillages might occur.
- all cracks and other voids to be grouted should be well cleaned out and washed to promote adhesion of the grout.
- wide cracks should be filled with a coarse aggregate of either stone or crushed brick. For cracks of widths between 30 and 70 mm, an aggregate size of 3 to 7 mm is recommended; for wider cracks, a size of 7 to 15 mm. Special care must be taken to ensure that no smaller particles are included, because their presence could impede the flow of grout.
- all cracks should be sealed on the surface to prevent the escape of grout. For cracks wider than 20 or 30 mm, a mixture of one part by weight of cement, one part of gypsum, and three of sand may be used. For narrower cracks, gypsum alone is better. This sealing is best done about two days before grouting, the surfaces to be grouted being kept wet during this interval.



a Preparation for grouting



b Grouting in progress

5.20 Grouting procedure, Rotunda, Thessaloniki

- to provide points of entry for the grout, short lengths of hose should be sealed at intervals in the surface filling of the cracks as seen in Figure 5.20a. Or, where internal voids are to be grouted without ready-made access through cracks, the lengths of hose should be sealed in holes drilled for the purpose at similar intervals of about 0.5 m.

Injection must proceed from the bottom upwards. To minimise the risk of damage by excessive internal pressure, the pressure at the nozzle should preferably be about 0.5 atmosphere, and not more than 1 atmosphere. Injection is interrupted each time grout appears at an entry point above the one in use, and pressure at the pump should be simultaneously reduced if the grout is being pumped. The nozzle should then be withdrawn and the short length of hose sealed with a tapered plug like that seen in Figure 5.19c.

After an interruption of 10 to 20 minutes, the procedure is repeated at the next higher level, or (if there are several entry points at the same level) at the next one along, until all points have been injected and sealed.

When injection is advancing vertically, it is important to avoid an excessive build up of hydrostatic pressure in the grout already injected. For this reason, the advance should be limited to 1 m per day.

When grouting is completed, it may be desirable to verify the extent to which cracks and other voids have been filled. For this purpose it is necessary to drill cores of 40 to 100 mm diameter. If excessive voids do remain, further injection should then be carried out through the drill holes.

As was stated at the beginning, grouting alone does not usually increase overall strength significantly because it develops little tensile strength. Adequate confinement to develop the potential increase in strength without added reinforcement is likely to be provided only by complete facings of good sound uncracked ashlar or brick. Where such a facing is lightly cracked but otherwise sound, it may be possible to repair it sufficiently to achieve much of the increase by bonding in new stone or brick across the cracks. In all other cases, additional reinforcement by steel bar or cable will be required.

Reinforcement will be most effective if it passes through the masonry, but it will usually be easier to set it in place externally, either on both sides of a wall or circumferentially around a pier, for instance. Setting it in this manner is also preferable in that it involves no irreversible change, whereas setting it within the masonry necessitates drilling, threading the reinforcement through, and then further grouting to develop bond and give protection. If much reinforcement is added internally, it may also modify significantly the stiffnesses of the masonry and its future ability to accommodate long-term structural movements.

Externally applied reinforcement will require anchorage plates at the ends, and these must be of sufficient area to distribute the tie forces into the masonry, unless it is circumferentially continuous. Both bars and anchorages may be lightly buried in chases cut in surface plaster or other rendering. But little protection against corrosion will result from this shallow cover, and other protection is necessary. It is essential that internal reinforcement is fully corrosion resistant to minimise the risk that it will later cause fresh damage. Some prestressing is desirable, but it is likely to disappear in time through creep in the masonry, especially if this has been extensively grouted.

Some further discussion, relevant chiefly to buildings of limited individual

historical importance, will be found in the manual on repair and strengthening of reinforced concrete, stone, and brick masonry buildings.

5.6.2 Strengthening of walls by applying skins of reinforced concrete

The addition of skins of reinforced concrete to one or both sides of walls that have been badly cracked or cannot easily be given the desired strength by grouting has obvious attractions. But it should be adopted only warily in historical monuments and other buildings of individual importance. Often the skin or skins can easily be substituted for existing surface treatments or hidden beneath a similar treatment. But they will have very different stiffnesses and permeabilities. Some slight cracking, if only from shrinkage of the concrete, is likely. When this occurs in an external skin, it will admit rainwater run-off, and the relative impermeability of the skins will then prevent easy evaporation. The greater stiffnesses of the skins will probably mean that most of the load is borne by them until they fail.

These drawbacks suggest that, in general, such skins should be applied only to the internal walls of buildings of the kinds discussed here, and chiefly just in buildings of fairly recent date and limited individual historical importance. When they are so applied, they should preferably be applied to both faces of the walls, with interconnecting ties at regular intervals unless the walls are much thicker than the skins. The result will be virtually new walls of sandwich construction, and it would be wise, before proceeding, to consider the alternative of complete reconstruction.



5.21 Reinforcement anchored to the wall surface, Hegemoneion, Samos

Careful prior stripping and cleaning of the wall surfaces is necessary, including the removal of all dust and fragments of brick or stone with air or water jets. Cracks may or may not be filled according to the circumstances and the judgement of the engineer: leaving them open may help by providing a key for the new concrete. Reinforcement is then fixed as shown above by means of metal dowels glued to the surface or by means of bars through the thickness. Ribs may be incorporated at intervals, as seen in Figure 5.22a. Concrete is usually applied by the Shotcrete or Guniting process as seen in Figure 5.22b. Typical thicknesses are from 30 to 80 mm. While work is proceeding, some temporary support may be required for floor or roof members.

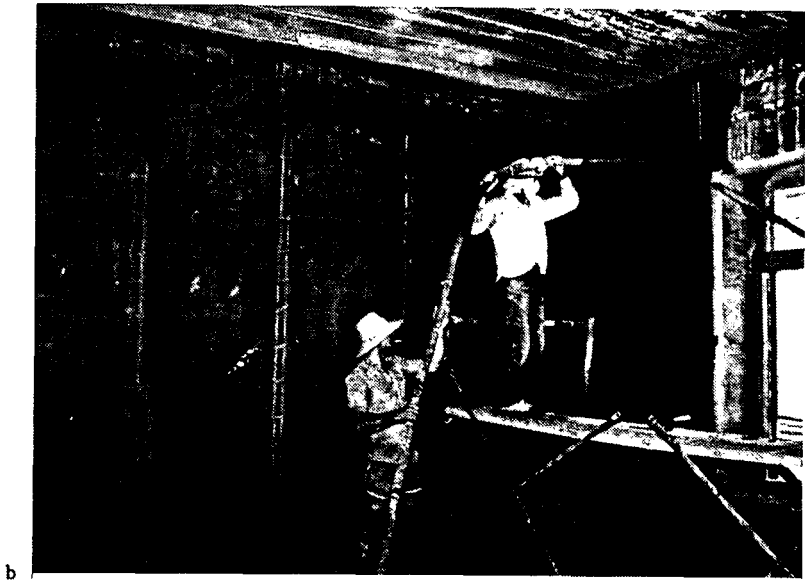
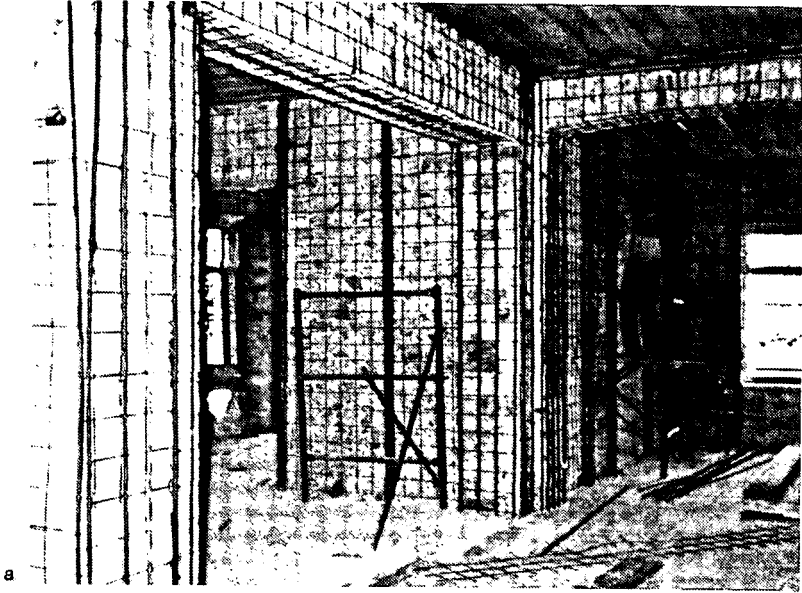

5.22 Application of reinforced concrete skins to internal walls
Hegemoneion, Samos

Further description will again be found in the manual on repair and strengthening of reinforced concrete, stone, and brick masonry buildings, including typical details applicable to multistorey buildings in urban nuclei. An example of the use of the technique is described in the case study of the Hegemoneion, Samos.

5.6.3 Strengthening of free-standing columns and minarets

From a statical point of view, a free-standing column or similar structure built of masonry could, in principle, be strengthened by applying a vertical prestress which will both anchor it to its foundation and eliminate tensile stresses due to lateral load. However, under the dynamic conditions of an earthquake, the prestressed form may not perform better. This is because the rocking response of the original form usually results in lower loads and gives a high ability to survive lateral shaking without collapse, as has been explained in section 3.2. Prestressing also presents practical difficulties. The prestress is unlikely to be permanent. And, to accommodate the tendons through which it is applied, considerable drilling of a difficult kind is called for. This drilling, and the grouting in place of the tendons, are, moreover, irreversible interventions and undesirable for that reason.

Experience shows that both monolithic columns and columns constructed from superimposed drums accurately cut and fitted together behave very well unless the horizontal bearing area has, somewhere, been considerably reduced - usually by deliberate cutting into the stone or other human action. The best strengthening measure is the restoration of the original bearing area. It is difficult, however, to do this effectively by adding patches: these too readily break away if rocking commences. Perhaps the only really effective procedure is the replacement of the damaged drum (or of a drum-like section of a damaged monolithic column) by a new drum. A possible alternative for the monolithic column is the fitting of a patch of similar stone cut as described in section 5.4.2, followed by local circumferential prestressing by means of an encircling band. An early precedent for this is to be found in the use of bronze bands around the tops and bottoms of all monolithic marble columns in Hagia Sophia, Istanbul, as seen below.



5.23 Base of a monolithic column, Hagia Sophia, Istanbul

In the column-like minaret, there are risks of high local compressions under seismic loading, leading to local crushing or splitting, as seen for instance

in Figure 3.84. This is likely chiefly if the masonry is of fairly low strength or is locally weakened by an entrance opening. Prior inclination or bowing will also make it more likely. Here the best method of strengthening is possibly the addition of an annular skin of reinforced concrete to the face of the central void that accommodates the ascending stair. An example is referred to in the case study of the Eger Minaret.

5.6.4 Strengthening of timber floors

Unless there is to be a major change in the use of a building that will lead to significantly higher live loads, the strengthening of timber floors (as distinct from the simple repair of earthquake damage or damage due to deterioration of the timber) will usually be necessary only to improve their capacity to resist in-plane bending and shear and thereby to distribute horizontal shears between the vertical load-bearing elements of the structure. Only local strengthening for this purpose is considered here. Connections between floors and walls and associated horizontal tying are discussed in section 5.7.5, as is the possibility of replacing an existing timber floor with a reinforced concrete slab.

Strengthening is best undertaken by adding an additional layer of boards at an angle to the existing boards, after carrying out any necessary repairs to the existing floor. If the new boards are well nailed through to the existing boards at each intersection and to the joists beneath, the angle of intersection is not of great importance, but it is suggested that it should not be less than 45°. Alternatively the additional layer could consist of plywood or hardboard sheet.

A further possibility is the casting of a thin layer of concrete, reinforced with steel mesh, over the existing boards and connected to them and to the joists by projecting nails driven into both. If the walls are given a reinforced concrete skin, the steel mesh in the floor concrete should be made continuous with that in this skin. Otherwise there should be direct connection to the walls.

5.6.5 Strengthening of arches and arched vaults

The inherent strength of arches, provided their supports do not move, has been pointed out in section 3.7. Hinging rotations, local splitting or crushing, slipping of voussoirs, and eventual collapse occur only when the supports - under the combined action of the arch thrusts and any other loading - move sufficiently to permit them. Any strengthening must, therefore, be considered primarily in terms of the whole system of arch plus supports, which is discussed in section 5.7.6. This is also true of barrel, groined, and ribbed vaults, which behave essentially as families of arches in this respect.

One measure of the margin of strength of the complete system of arch or vault plus supports is, however, the separation of the supports at the springing level which is possible without collapse of the arch or vault. Strength measured in this way will be diminished by deformation of the arch or vault, particularly by local crushing or splitting and slipping of the voussoirs, as seen in Figure 3.37.

Where strength has been diminished in this way, it may be desirable to replace the damaged voussoirs or to jack back into place any that have slipped. But this must be done as part of an overall strengthening which also includes the necessary associated closure of the separation of the supports at the springing level. If it is done in a major historical monument, a precise record

is essential because some evidence of the past history will have been destroyed.

Simply filling any cracks that have opened will add no strength. Since it will prevent their subsequent closure by a reversal of the movements that led to them, it might even be regarded as a weakening because the extent of future separation of the supports that is possible without collapse will have been permanently reduced. If other measures are taken to prevent significant future separation (such as the use of ties as discussed in section 5.7.6), it will, however, be desirable. It is suggested that the filling is then done with a grout that is slightly weaker than the existing mortar and that it is done immediately before the final stressing of the ties.

5.6.6 Strengthening of domes and domical vaults

Domes, and domical vaults with a large rise in the central region, differ from arches and arched vaults in that their surface geometry permits the containment of all or part of the radial horizontal thrusts by circumferential reinforcement of the dome or vault itself.

The absence of effective reinforcement of this kind, together with the tensile weakness of the masonry, means, however, that the domes and vaults of historical structures are invariably cracked and do thrust outwards. Thus it is possible to strengthen them significantly by adding circumferential reinforcement on the outside near the base (for a dome) or near the base of the central domical region (for a domical vault).

The added reinforcement should be prestressed to the full calculated circumferential tension for an idealised equivalent uncracked membrane. Care is, however, required in stressing because there will be a tendency to close the existing cracks. This will either cause the dome or central part of the vault to move inwards slightly in relation to the supporting structure or to pull the supporting structure inwards as well. Closure of the cracks will, it itself, be beneficial, provided that it takes place uniformly and is not impeded by local blockages of the cracks. But there may be a further hazard if there is mosaic or fresco decoration on a plaster bed on the inner surface, and this bed is no longer fully in contact with the structural dome or vault. The stressing procedure must therefore be planned as part of the overall strengthening scheme and with clear overall objectives. Where cracks are closed, they should be carefully cleaned beforehand through the whole thickness. Otherwise they should be filled in the same manner as described above for arches and arched vaults.

The reinforcement should also be corrosion resistant or should be protected against corrosion, though this is less important where it will remain accessible provided that regular inspection can be relied upon. One possibility for protection is to encase the reinforcement in a sufficient cover of dense concrete.

In a very few instances - where there is important decoration on a plaster bed on the inner surface and part of the dome or vault is very badly cracked or otherwise deteriorated - partial rebuilding of this cracked or deterioration portion while the plaster bed is supported from below may be justifiable. This is a procedure calling for considerable skill and care. Another possibility in these and similar circumstances is to cast a complete skin of reinforced concrete on one surface, although this should rarely be necessary and it is not recommended as a normal procedure. It will be justified chiefly when much of the masonry is in poor condition and unlikely to be able to

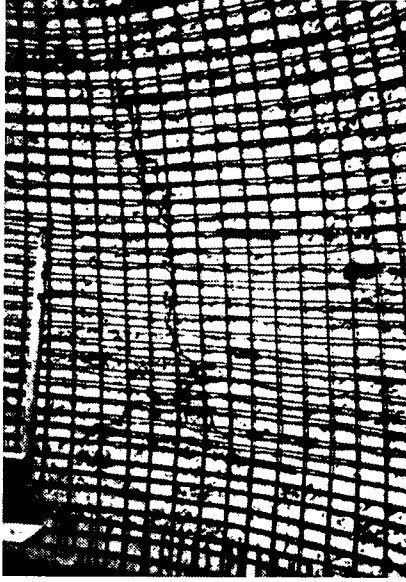

a

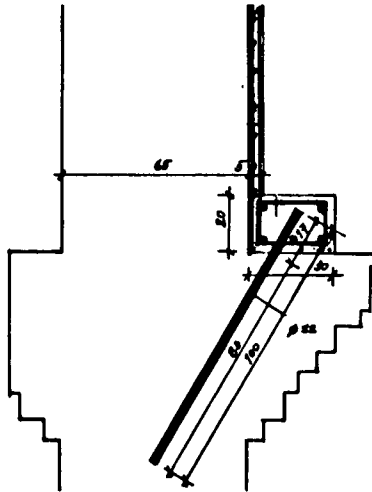

b

5.24 Strengthening of the dome, Cathedral of Dubrovnik

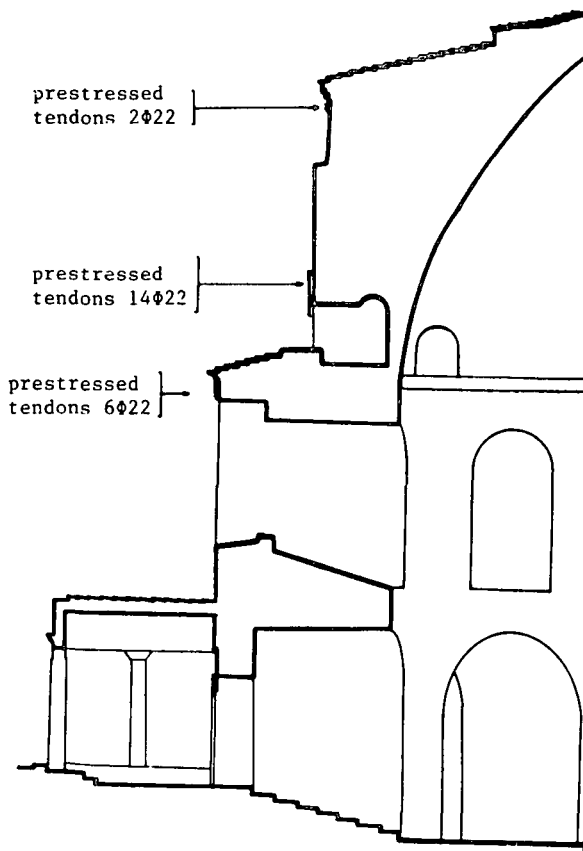

5.25 Strengthening of the dome, Rotunda, Thessaloniki

be able to withstand the forces exerted by a prestressed tie, and where its complete replacement by a reinforced concrete shell is inadmissible. An example is illustrated in Figure 5.24 and further described in the case study. It will be seen that the new skin is continuous with the tie and that both are anchored to the base structure.

The Figure above illustrates a more normal use of ties alone.

5.7 Overall strengthening above ground

It has already been stated that all strengthening should be considered in terms of its contribution to the overall seismic response of the structure. On the one hand, this means making good weaknesses that have been disclosed by the investigation and analysis of the structure as it is, especially those indicated by past earthquake damage. On the other hand, it may mean making the structure conform more closely - where considerations of historical and architectural character and authenticity allow - to the usual norms for good

earthquake resistance. In practice however, the two will often amount to virtually the same thing.

It will be most convenient here to consider overall strengthening under the headings of those of the usual norms as are most relevant to the structures considered in this manual:

- reduction of mass, particularly at high level.
- avoidance of large torsional loadings resulting from unfavourable relative distributions of mass and stiffness.
- development of all potential strength and ductility by appropriate interconnections of elements (including prestressing).

One possibility will not be discussed further. This is the substitution of a different structural system for the existing one. An example would be the insertion of a complete frame of reinforced concrete in a previously unframed masonry structure, with the intention that it should carry all loads in the same way as a similar frame in a modern structure. (It might be cast in chases cut in the existing structure, or this structure might be partly dismantled and subsequently re-erected around it.) This procedure is not recommended. It would result in an excessive loss of authenticity; it would be an irreversible intervention; and there would be considerable difficulties in ensuring safety of the structure during the work if the new frame were accommodated in chases cut into it. The resultant hybrid structure would, moreover, be difficult to analyse realistically because of the difficulty of taking properly into account the stiffening effect of the remaining masonry on the behaviour of the frame.

Only those methods of strengthening that do retain the original structural system in its essentials will be considered.

5.7.1 Removal of excess mass

Excess mass is most frequently found as a filling over vaults to give a level floor surface or as an earth covering to the roofs of certain traditional types of dwelling primarily to give weather protection. Because it is at levels well above the ground it leads to considerable increase in seismic loads while adding little or nothing to the strength of the structure.

Heavy fills over vaults should be removed, as seen in Figure 5.26, and lighter floors substituted.

Lighter types of weather protection (and better forms of insulation) should be substituted for the heavy roof coverings of earth.

5.7.2 Improvement of the distributions of mass and stiffness

Most historical monuments and many other buildings in old urban nuclei probably had fairly compact forms with fairly uniform distributions of mass and stiffness when first built. Subsequent changes and additions to meet changing and growing needs have, however, resulted in less satisfactory forms. Typical changes have been repeated rearrangements of internal walls in buildings in urban nuclei. Typical additions have been repeated additions to these same buildings to increase accommodation, the construction of new buildings immediately alongside existing ones, and the addition of new chapels, sacristies, bell towers, etc., to churches.



5.26 Fills removed over side aisle and narthex vaults,
Hagia Sophia, Thessaloniki

Where repeated internal rearrangements have taken place in older multistorey buildings, there will usually be little reason why some further rearrangement - possibly returning to an arrangement closer to the original - should not be introduced. An example is given in the case study of the Rector's Palace, Dubrovnik. Where only the exterior of the building is thought to be fully worthy of preservation, it will be permissible and may be desirable to introduce a completely new internal arrangement. An example of this is given in the final case study.

Where additions have been made that will, in a future earthquake, tend to pull away from and then batter the main structure, it will be advisable to introduce a separation if this is practicable. The separation should be wide enough to eliminate the risk of battering if the two structures vibrate differently. Some reinforcement may be necessary on one or both sides of it to compensate for losses of support. An example is given in the case study of the Rector's Palace, Dubrovnik.

5.7.3 Improvement of structural interaction in classical temples and colonnades

Past experience shows that the seismic performance of these structures - like that of free-standing columns discussed in section 5.6.3 - is good, provided that they are in good repair. This is true in spite of - and perhaps partly because of - the absence of tensile continuity and moment-resisting joints. There is no evidence to support the view that the introduction of reinforcement to provide either of these would improve performance. Since, moreover, this would be an irreversible intervention, would destroy some of the historical authenticity of the structure, and might cause future damage through corrosion of the reinforcement, it is not recommended.

Structural weakening occurs largely through local damage to blocks of stone and consequent loss of some of the original bearing contact, the best remedy for which is the replacement or repair of the damaged blocks in the ways already discussed in sections 5.4.2 and 5.6.3.

Where there have been partial collapses which have reduced the possibilities of overall interaction or created a likelihood of serious torsional loads, partial reconstructions to restore some of the losses in a manner as close as possible to the original construction should be considered if they are thought to be admissible from other points of view. As yet, the seismic behaviour of these structures is, however, imperfectly understood. It is not possible, therefore, to give a more definite recommendation about the circumstances in which this partial restoration of losses is desirable from the seismic point of view.

An example is given in the case study of the Erechtheion.

5.7.4 Improvement of structural interaction in halls with open non-thrusting timber roofs

The most useful overall strengthening in structures of this type will be improvement of the interconnection of the longitudinal walls and the shorter transverse walls at the ends. Lateral stability of the flexible longitudinal walls may also call for improvement. This may be achieved by improving the transverse interconnections between the walls through the horizontal tie members of the roof trusses and, where there are galleries, through the beams of the gallery floors. But it should be recognised that these interconnections will reduce the natural periods of vibration and may, thereby,

result in some increase in seismic loads.

5.7.5 Improvement in structural interaction in multistorey buildings

In the structures typical of the palace type of historical monument and of most other buildings in old urban nuclei, it is essential, for good response to earthquake loading, that the bearing walls should act together in resisting the horizontal shears and be loaded in proportion to their respective strengths. This calls for good interconnections where walls meet, floor systems strong and stiff enough to transmit horizontal shears as necessary between different sections of wall, and adequate tying of external walls to one another to prevent them from falling outwards. Where external walls are interrupted by doors or windows, there should also be adequate connection across the interruption, either directly or through the floors. Often the existing structure will be found to be deficient in one or more of these respects, so that improved interconnections or ties or improved floor systems are called for.

Some capacity for post-elastic (or post-cracking) deformation of the bearing walls is also desirable, and this capacity is invariably slight in pure masonry walls, although it may be greater in timber-framed walls with a masonry infill. It is more difficult to increase this capacity to a worthwhile degree, so it may be better to aim simply at adequate elastic strength. But a worthwhile increase may be possible where it is feasible and admissible to introduce framing elements within the thickness of the walls.

Many techniques are available for improving the connection between walls which meet at a bonded junction. These range from local repair of the existing masonry bond, to repair of the existing bond coupled with the insertion of additional stitching blocks or metal plates, and overall grouting coupled with the addition of reinforcement anchored at the junctions in such a way as to tie the walls together. Another possibility is to make the connection through reinforced concrete skins applied to both walls and with the reinforcement continuous across the junction. All these techniques are more fully described in the manual on repair and strengthening of reinforced concrete, stone and brick-masonry buildings. Choice between them must be made in the light of the historical importance of the structure, the extent to which some modification of the existing construction is admissible, the present condition, and the choice of technique for any necessary local strengthening of the walls.

The most widely applicable and valuable technique is that of the insertion of metal ties for linking external walls on opposite sides of a building across its width. Ties have frequently been inserted at floor levels in the past when walls have shown a tendency to bulge or rotate outwards, and they have frequently proved their value as the ties inserted in the Rector's Palace, Dubrovnik after the 1667 earthquake did in 1979. Unless such ties are rendered unnecessary by the substitution of reinforced concrete for the existing timber floors, they should be threaded through from wall to wall as before (and as shown in Figure 3.53), and they must be anchored in the walls by spreader plates of sufficient size to distribute the tie forces into the walls without pulling through (see Figure 5.27). An upper limit to the strength required will be given by the full calculated seismic overturning force on the wall that is restrained, though some reduction might be made for the restraints given by return walls. Some prestress is desirable to avoid slackness.

When ties are inserted in this manner, there is the further possibility, if



5.27 Tie anchorage, Rector's Palace, Dubrovnik



5.28 Balsiceva Kula, Ulcinj (upper left)

the ties are suitably placed, of returning leaning walls to a more nearly vertical position by continued controlled stressing in much the same way as with the temporary external ties seen in Figure 5.4. If this is attempted, it is again important to ensure first that no debris or other obstruction prevents a uniform closure of all gaps associated with the inclinations of the walls.

Existing floors will almost invariably be of timber (unless they are carried by masonry vaults, in which case reference should be made to section 5.7.6). Strengthening of the floors themselves has already been discussed in section 5.6.4. They will already be supported by the walls. Any necessary repair at the points of support may, in conjunction with new horizontal ties, provide adequate shear transfer. If not, steel straps nailed to the floor boards or joists and anchored in the walls may be used as illustrated in Figures 8.41 and 8.42 of the manual on repair and strengthening of reinforced concrete, stone and brick-masonry buildings.

Two other possibilities are the introduction of continuous belt courses of reinforced concrete in the outer walls at each floor level, and the complete substitution of the existing timber floors by reinforced concrete slabs. These will provide the required horizontal diaphragm action (the first in association with the existing floors). But both involve substantial change in the original structural system and will be undesirable, for that reason, in many historical buildings. And both have two other drawbacks. One is that considerable cutting into the existing walls is necessary to accommodate and provide support for them. This will weaken the walls and will call for special care during execution of the work. The second is that the reinforced concrete will usually be considerably stiffer than the masonry of the walls, and will tend to have different long-term and cyclic movements due to shrinkage, temperature change, etc. This latter tendency will probably lead to fresh cracking of the walls, and the difference in stiffness, coupled with the weakening of the walls by the cutting of chases in them, may lead to further damage being inflicted on the walls during an earthquake. Where recent earthquakes have affected masonry buildings, some with timber floors and traditional timber reinforcements in the wall masonry and some with reinforced concrete floors, the former have shown little damage while nearby examples of the latter have suffered extensive horizontal cracking and displacements at the floor levels. Figure 5.28 shows more extensive damage to the upper storey of a defence tower caused by a reconstruction of the roof in reinforced concrete. Any introduction of horizontal elements of reinforced concrete into a structure whose vertical bearing elements remain the original masonry walls should, therefore, be undertaken only with considerable caution. It will be less likely to have undesirable consequences if the walls are, at the same time, strengthened in some way or if, for instance, all internal walls are replaced by walls of reinforced concrete and the external walls strengthened by reinforced concrete skins as in the Palace in Dubrovnik described in the final case study.

Some methods of strengthening the walls themselves have already been described in sections 5.6.1 and 5.6.2. Strengthening by improvement of the ductility calls for the introduction of vertical framing elements in association with reinforced concrete horizontal belt courses. Further cutting into the walls is necessary for this purpose, possibly at the junctions with internal return walls and at external corners. Light reinforced concrete 'columns' must then be cast in the chases, their reinforcement being linked to that of the belt courses as described in more detail in the manual on repair and strengthening of reinforced concrete, stone and brick-masonry buildings. The 'columns' will, however, be called upon to act more as ties and should be reinforced

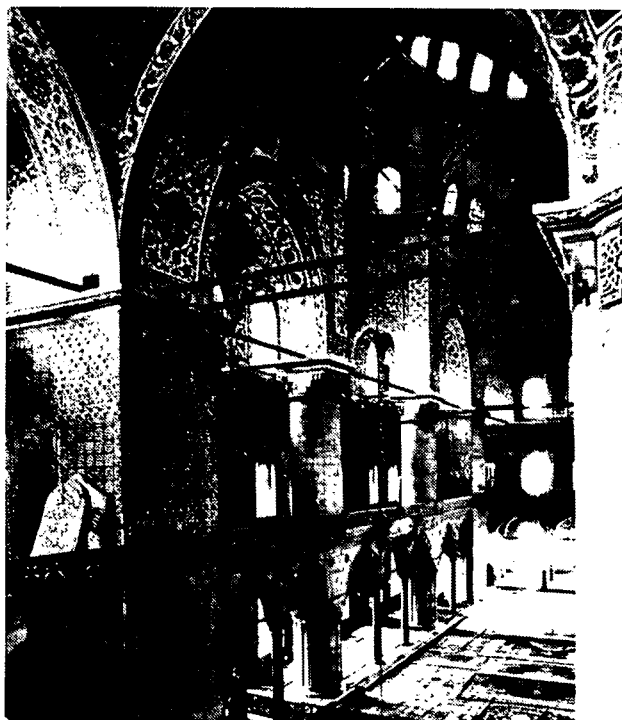

5.29 Iron ties, Mosque of Sultan Ahmet, Istanbul

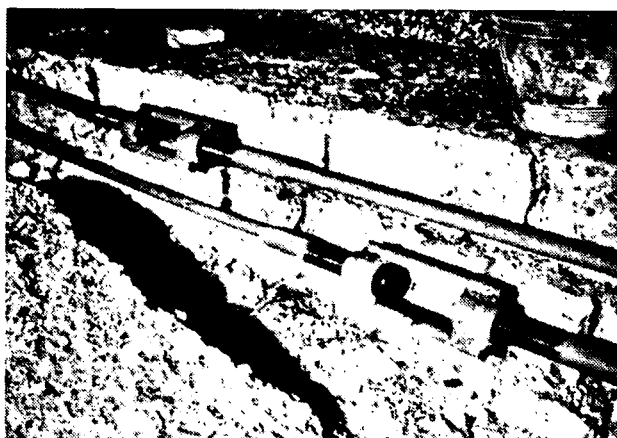

5.30 New ties, Cathedral, Dubrovnik

accordingly. Their purpose is not to carry vertical compression but to provide tensile confinement to each section of wall after it cracks in shear. This technique is, however, even less applicable to historical monuments than the other uses of reinforced concrete. It should be considered chiefly for fairly recent buildings of regular plan form with walls of uniform thickness of not more than about 500 mm.

5.7.6 Improvement of structural interaction in arched, vaulted, and domed structures

Vaults and domes do not, in themselves, provide good interconnections between the supporting piers and walls from the point of view of seismic performance. They tend, rather, to push these apart and to do so progressively in an irreversible manner. The most desirable intervention is, therefore, the addition of ties at or near the springing level, or the addition of buttresses to serve a similar purpose. Where multiple vaulted bays carry floors, there may also be a need for more effective horizontal diaphragms to distribute seismic shears between walls or provide more effective lateral bracing to them. The use of circumferential tensile reinforcement to strengthen domes and domical vaults has already been considered in section 5.6.6 and will not be considered further - only the use of ties spanning freely between their supporting piers or the corresponding use of buttresses will be considered here.

Free-spanning ties have the drawback that they are necessarily visible. The intrusion may be considered aesthetically unacceptable. But there is a long tradition of using them, especially in the Byzantine and Ottoman monuments in the Balkan region as seen in Figures 3.49 to 3.52 and Figure 5.29, and modern high-strength steels allow the use of smaller cross sections. Their use should not, therefore, be ruled out without full consideration.

The best position for ties is slightly above the springing level of the arch or vault, where they should preferably be threaded through the support and adequately anchored on the far side. Sometimes an alternative position, out of sight, is just above the crown. This is possible only if the supports continue to this level and both carry sufficient compression there and have sufficient strength to transmit the tie force down to the level where the arch or vault thrust acts. In practice, this location will be suitable chiefly for ties over arches that carry domical vaults that rise well above them, often to support galleries in churches or mosques or upper floors in important buildings. Figure 5.30 shows ties in a similar position over an aisle of the Cathedral of Dubrovnik.

Ties to vaulted floors can, if they are set at the higher level just referred to, form part of a trussed diaphragm system as illustrated in Figure 5.31. This will have a stiffness comparable with that of the reinforced concrete systems referred to in the previous section. But there will be less risk of causing damage to the vertical bearing structure because this will now usually be of a different form.

Whatever their position, ties should be capable of taking the full horizontal thrusts of the arches or vaults, possibly with some allowance for the additional thrusts due to vertical seismic loading when the spans are large. They should also be prestressed to a tension close to the thrust under static load, and they may be used, by continued stressing suitably controlled, to partly close a previous separation. (See also, in this connection, section 5.6.5.)



5.31 Diaphragm system above ground floor vaults, Rector's Palace, Dubrovnik

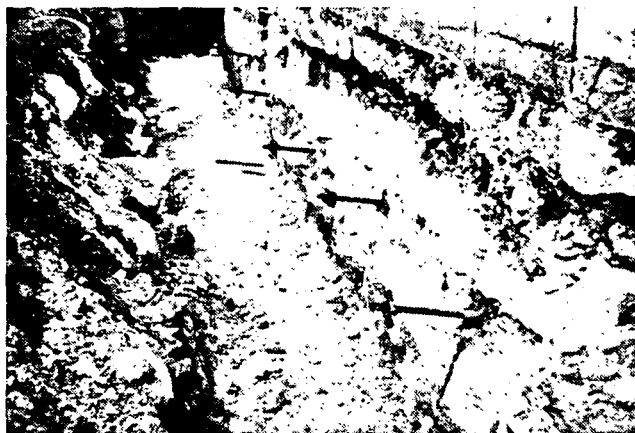

5.32 Shear connectors for new foundation beam, Rector's Palace, Dubrovnik

The addition of buttresses was the other expedient often used in the past to resist the outward thrusts. Buttresses, being much more bulky, were inevitably more obtrusive if they projected externally, and they sometimes obscured the natural lighting of the interior. There was also the risk that they might fail to serve their intended purpose if consolidation and settlement of the ground on which they stood led to their tilting away from the pier or wall against which they were built.

In principle, similar buttresses could now be prestressed against a pier or wall, but the difficulty of compensating for long-term settlement would remain and might call for provisions for future jacking. The addition of internal shear walls - suitably linked by means of ties or horizontal diaphragms to the piers or walls in need of support - will be preferable if it is feasible and does not cause excessive obstruction. Like new external buttresses, they will, of course, call for adequate new foundations. Ties avoid this requirement.

The remaining possibility is to reduce greatly the horizontal thrusts on the supporting piers or walls by substituting lighter shells of reinforced concrete for the existing masonry vaults, perhaps with upstanding transverse wall-like ribs or beams. Like other major substitutions, this is a technique best reserved for comparatively recent structures where nothing of great value would be lost through the destruction of the original vaults.

Examples of some of the techniques referred to above are given in the case studies of the Rotunda, Thessaloniki; the Church of Hagios Andreas, Peristera; the Boyana Church, Sofia; the Cathedral, Dubrovnik; the Calvinist Church, Bekes; and the Rector's Palace, Dubrovnik.

5.8 Strengthening of foundations

Since the type of ground and the design and condition of the foundations also influence the structural response to an earthquake, they must also be considered in planning an overall strengthening scheme. Possibilities of improving the ground are limited. Strengthening of the substructure is usually easier and a wider range of techniques is available to deal with the different situations that arise - the term strengthening being used here to denote any operation which improves the support given by the ground or, more specifically, improves the seismic response.

5.8.1 Consolidation of the ground

Unstable soils, particularly those liable to liquify, pose a threat of serious differential settlements during an earthquake. Soils in the following categories should be regarded as potentially unstable:

- saturated sands: large grained sands with a relative density less than 1/3; medium and small grained sands with a relative density between 1/3 and 1/2; and fine grained sands with a relative density between 2/3 and 1.
- saturated clay with a sensitivity greater than 8.

Where the threat referred to exists, the ground should be consolidated, either by drainage or by chemical means. If the ground is drained, the water level should be permanently lowered to at least 5 m below the foundation. Care is necessary, in doing this, to avoid inflicting damage by the settlement that

the consolidation will cause.

Possible chemical means include the injection of water glass to achieve the silication of loess and saturated sands, the injection of carbamide polymerides in saturated sands, and the injection of emulsified asphalt in large-grained sands. Specialist advice is recommended, however, before any of these techniques is adopted.

5.8.2 Strengthening of existing footings

Where the ground is potentially able to carry the structure safely (or has been suitably consolidated), differential settlements may still occur if the footings or other foundation do not distribute its weight sufficiently or carry it down to a suitable stratum. There is also a possibility of relative lateral displacements occurring if the substructure is not sufficiently unified. However, with structures of considerable age, any differential settlement will usually have stabilised long ago if there have been no recent changes - as was pointed out in section 3.4. A need for strengthening is most likely to arise where the above ground works have resulted in significant changes in loading at foundation loading, or where there has been some deterioration of the original foundation, such as the rotting of timber piles or bearers.

Inadequate existing footings may be strengthened most readily by casting new reinforced concrete members alongside them, after providing for the necessary shear transfer as shown in Figure 5.32. The sketches at a below illustrate the principle with and without provision for jacking to ensure transfer of load to the new members without further settlement. Alternatively, the existing footings may be underpinned with wider reinforced concrete members, as sketched at c below, following normal underpinning procedures.

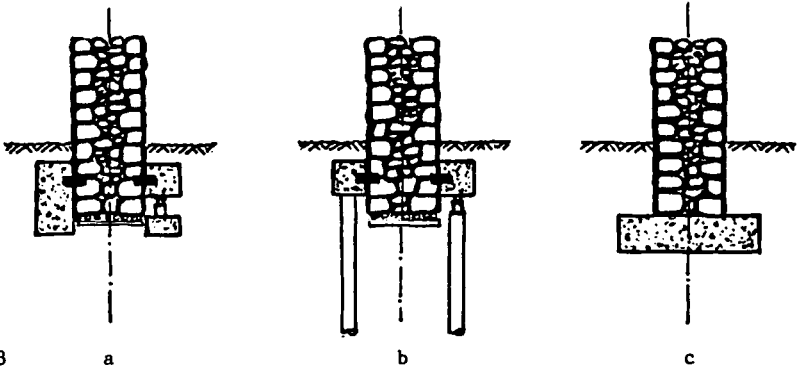

Where it seems desirable to carry the loads of the superstructure to a lower firmer stratum, new piles must be driven. Usually it will be preferable to drive them alongside (rather than beneath) the existing footings. This again calls for the casting of new reinforced concrete members alongside the existing footings with adequate shear connection, as sketched at b above. Provision for jacking, as shown at the right of the sketch, will usually be necessary to ensure a proper transfer of loads to the piles.

Examples of the strengthening of existing footings to provide a more unified substructure and to increase the bearing capacity to take the additional loads

imposed by above-ground strengthening works are given in the case studies of the Rector's Palace, Dubrovnik, and the Hegemoneion, Samos.

5.8.3 Vibration isolation

In principle, a structure can be isolated from movements of the ground on which it stands, at least from horizontal movements, if it is free to slide relatively to the ground. It will remain at rest, and free of inertia loads, while the ground moves to and fro beneath it. This will be tantamount to an overall strengthening.

Complete isolation would, however, be undesirable. It would lead to unwanted relative movements under frequently acting horizontal loads like the wind. Thus a more realistic aim is to provide normal restraints to relative movements up to the maximum values of frequently occurring loads, but only constant restraints of these magnitudes when larger loads would otherwise arise.

To achieve this aim calls for the incorporation of elasto-plastic spring elements in the foundation.

Experience is hitherto limited to applications to highly sensitive new structures, in which the spring elements can be incorporated at the time of construction. If the system were to be applied to a historical structure of significant size, a major underpinning operation would be called for, including the creating of a rigid box-like base for the structure. It seems highly unlikely that the costs, difficulties, and risks of this would ever be justified, even if the major change in the historical form below ground were thought to be acceptable. It has, however, been suggested that there may be some potential applications to small monuments and, perhaps, to some museum buildings housing exhibits that cannot easily be protected in other ways. A summary of recent Hungarian studies is therefore referred to in the following chapter.

6. BIBLIOGRAPHY AND SOURCES

Most of the content of this manual is new. This means that there are few existing publications to which the reader can turn for further information or guidance, other than those devoted to seismology generally, to aspects of architectural history, and to the analysis and design of modern structures. It is not considered necessary to list works of these latter kinds here, so the bibliography that follows is very brief.

Where the input reports of the members of the Working Group and other similar contributions have been drawn upon by the consultant in writing certain sections, they are referred to in section 6.2. The chief contributions of this kind have been to the case studies, and these are referred to separately at the end of each study.

Section 6.3 lists the sources of the illustrations to chapters 2 to 5.

6.1 Bibliography

Chapter 2:

- Feilden, B M, Conservation of Historic Buildings, Butterworth Scientific, London, 1982.

Chapter 3:

- International Association for Earthquake Engineering, Basic Concepts of Seismic Codes, vol.1, part 2, 'Non-Engineered Construction', IAEE, Tokyo, 1980. (chiefly relevant to the performance of smaller buildings in urban nuclei)
- Mainstone, R J, Developments in Structural Form, Allen Lane and Penguin, Harmondsworth, and MIT Press, Cambridge, Mass, 1975, 1983. (wide general coverage, not specifically concerned with earthquakes; extensive further references)
- Mainstone, R J, 'Historic Buildings as Structures', Appendix I to B M Feilden, op.cit.

Chapter 4:

- Feilden, B M, op.cit.
- Institution of Structural Engineers, Appraisal of Existing Structures, ISE, London, 1980.

Chapter 5:

- Feilden, B M, op.cit.
- International Association for Earthquake Engineering, op.cit.
- United Nations Industrial Development Organisation, Building Construction under Seismic Conditions in the Balkan Region, vol.5, 'Repair and Strengthening of Reinforced Concrete, Stone and Brick-Masonry Buildings', UNIDO/UNDP, Vienna, 1983. (relevant to some buildings in urban nuclei)

- Schultze, E, Techniques de Conservation et de Restauration des Monuments (Terrains et Fondations), ICCROM, Rome, 1970. (relevant to foundations, not specifically concerned with earthquakes)

6.2 Sources for the text

Section 2.1:

- IIO International Congress of the Architects and Technicians of Historic Monuments, Decisions and Resolutions, Document 1, 'International Charter for the Conservation and Restoration of Monuments and Sites', Venice, 1964.

Section 2.2:

- Kuban, D, and Yorulmaz, M, 'On the organisation of studies and intervention methods for the preservation of historical monuments and sites in earthquake areas' and 'Methodology of structural classification of historical buildings in the Medieval Turkish and Ottoman periods', Turkish input reports, 1982.

Section 3.2:

- Ambraseys, N N, Working paper for a UNESCO/ICOMOS meeting, Paris, 1977.
- Zambas, C, 'Articulated Ancient Greek and Roman buildings: General identification of structural characteristics, damage and strength assessment and intervention methodologies', Greek input report, 1982.

Section 4.3.4:

- Venkov, V, Preliminary draft, Bulgarian input, 1983.

Section 4.5:

- Powell, G H, 'Notes on earthquake resistance, strengthening and repair of cultural and historical monuments', Discussion paper for the third Working Group meeting, 1983. (also the basis for some recommendations in sections 4.6 and 4.7)

Section 5.3:

- Penelis, G, Preliminary draft, Greek input, 1983.

Section 5.4.2:

- Zambas, C, op.cit, Greek input report, 1982.

Section 5.6.1:

- Penelis, G, Preliminary draft, Greek input, 1983.

Sections 5.8.1 and 5.8.2:

- Venkov, V, Preliminary drafts, Bulgarian inputs, 1983.

Section 5.8.3:

- Csak, B, D W Haase, and J Peredy, 'Elastoplastic spring elements for diminution of seismic forces and absorption of kinetic energies', paper submitted to the 8th World Conference on Earthquake Engineering, 1984. (does not deal with applications to historical structures)

References to sources among the consultant's own publications will be found in Developments in Structural Form. (op.cit. in bibliography for chapter 3)

6.3 Sources for the illustrations

All illustrations to the preceding chapters are from photographs or drawings by the consultant and are his copyright except for the following:

Figures 3.6, 3.23, 3.26, 3.31: K Anadol, Yapi Merkezi, Istanbul.

Figures 3.25, 4.5, 5.30, 5.31, 5.32: D Anicic, Zagreb.

Figures 4.6, 4.7, 4.8: Institute of Earthquake Engineering and Engineering Seismology, Skopje. (from IZIIS Report 81-76)

Figures 2.1, 2.2, 2.3: D Kuban, Istanbul.

Figures 3.36, 3.53, 5.10, 5.11, 5.21, 5.22: A Miltiadou, Athens.

Figures 4.1, 4.2, 4.10, 5.18, 5.19, 5.20, 5.25: G Penelis, Thessaloniki.

Figure 3.13a: from G P Stevens, The Erechtheum.

Figure 5.7: 9th Superintendency of Byzantine Monuments, Thessaloniki (Mrs Nicolaidou).

Figures 3.84, 3.86, 3.87, V Venkov, Sofia.

Figure 4.9: M Yorulmaz, Istanbul.

Figures 3.4, 4.3, 5.2, 5.13, 5.14, 5.15: C Zambas, Athens.

7. CASE STUDY: THE ERECHTHEION, ATHENS

7.1 Introduction

The work undertaken on the Erechtheion from 1979 onwards is the most important recent example of the repair and strengthening of a major classical monument built of finely dressed and closely fitted unmortared blocks of marble in the manner described in section 3.3.2.

Repair and strengthening were necessary chiefly on account of damage to the masonry by the rusting of iron cramps and other reinforcements added in an earlier intervention and by further damage caused by recent air pollution. But the structure was also still seriously weakened by the effects of a much earlier fire, by a nearby explosion, and by previous human intervention, and the risk of future earthquakes had to be taken into account in devising the restoration scheme.

7.2 Description

The Erechtheion is an Ionic temple constructed in the late 5th century BC on the north side of the Acropolis rock. The surface of the rock dips here to both north and west, which may be one reason for the unique form of the structure that is best seen in the restored plan and elevations reproduced in Figures 7.1 to 7.3. The central block is flanked by porches of very different height on the north and south as well as having a porch at the east. The small south porch is notable for the use of sculptured female figures (caryatids) instead of columns to support the roof.

In later years the temple became a church and then the harem of the Turkish governor of Athens, with the consequent destruction of the original internal arrangements, although the marble of the walls had already been damaged internally by the fire referred to above.

When the Turkish occupation ended, later accretions were removed. But the structure was largely roofless, great parts of the north, south, and west walls had fallen, and the north corner of the east porch had been taken away.

A partial reconstruction of the south and west walls was undertaken in 1835-47, and a major further reconstruction in 1902-08. The walls were rebuilt with some transference of blocks and with some new masonry to heighten the south wall. There was also considerable re-erection of fallen members of the north and south porches. In the rebuilding, an attempt was made to unify the masonry as in the original construction by means of embedded iron cramps, and to support damaged architraves and other parts of the ceilings of the porches from steel beams placed above them as seen in Figure 7.4. In the south porch, iron columns were also introduced between the caryatids to relieve them of load from the roof.

7.3 Structural condition

General views of the structure as it existed after the 1902-08 reconstruction and up to the start of the works described here are reproduced in Figures 7.6 and 7.7, and may be compared with the view towards the end of the Turkish occupation reproduced in Figure 7.5. The diminution of the strength of the walls by fire damage is apparent from Figure 7.7 and from the detail

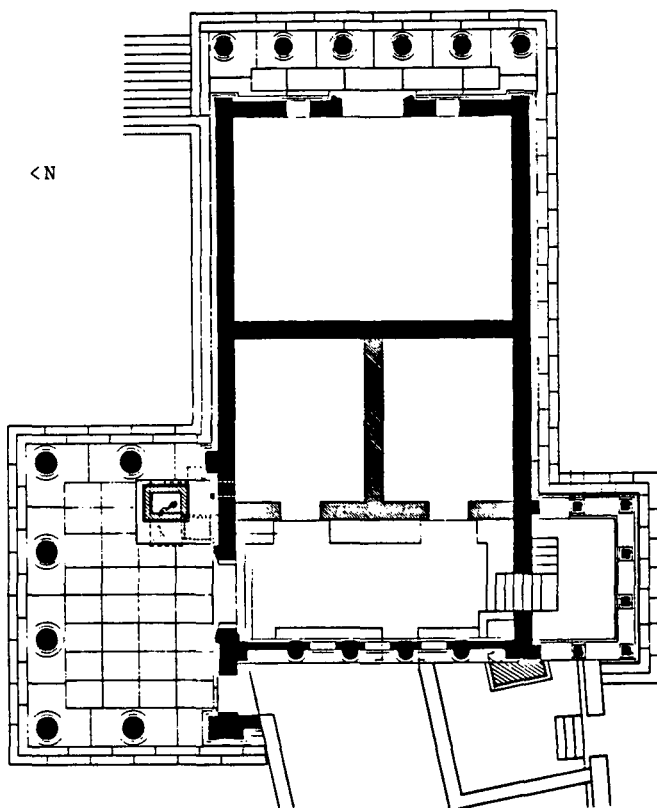

7.1 Restored original plan (1:200)

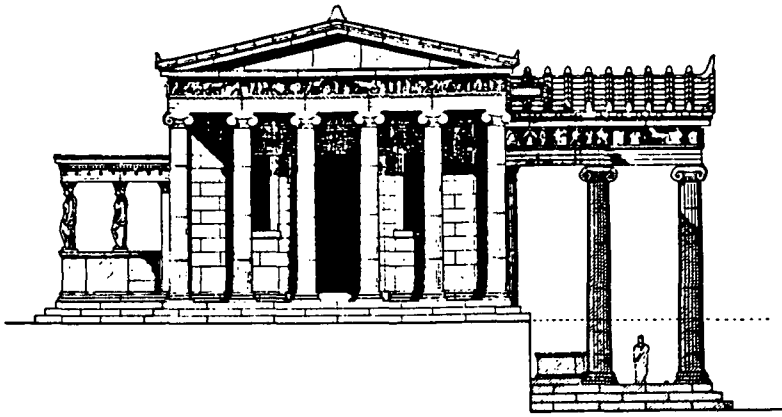

from the east

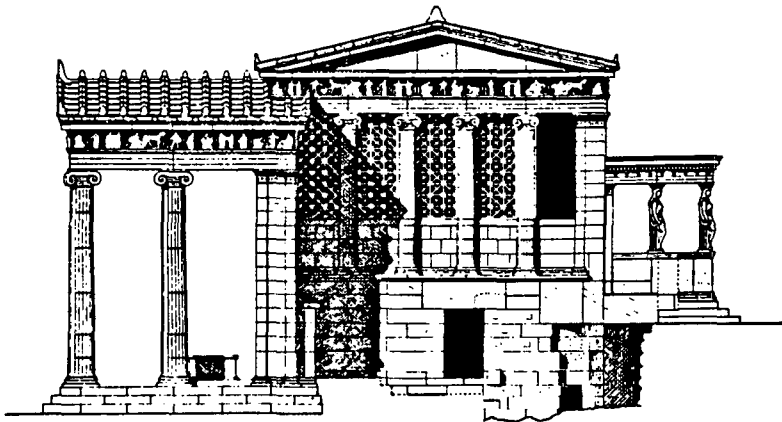

from the west

7.2 Restored original elevations (1:200)

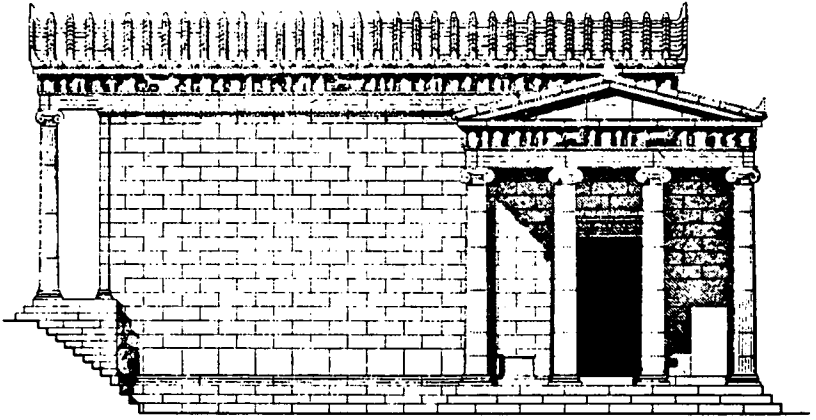

north side

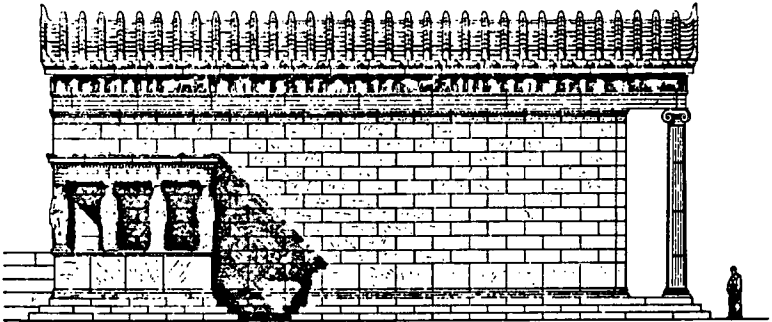

south side

7.3 Restored original elevations (1:200)

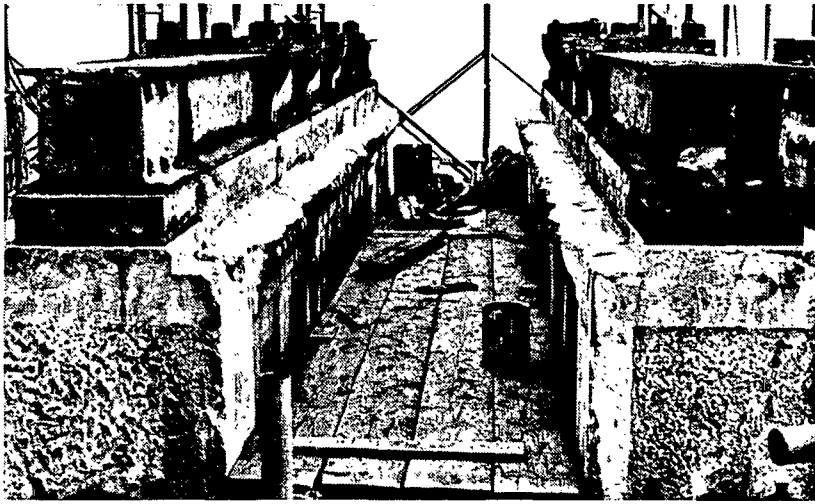

north porch



south porch

7.4 Steel supporting beams installed in 1902-08

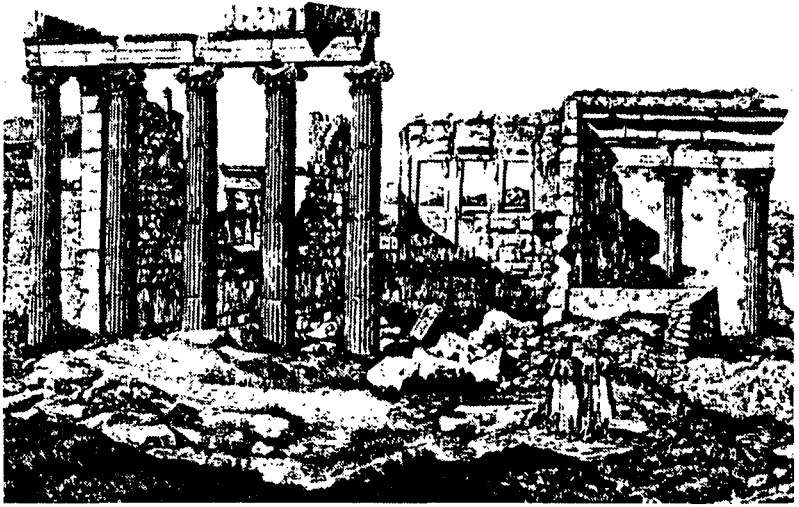

7.5 View from the northeast in 1819 (Thurner)

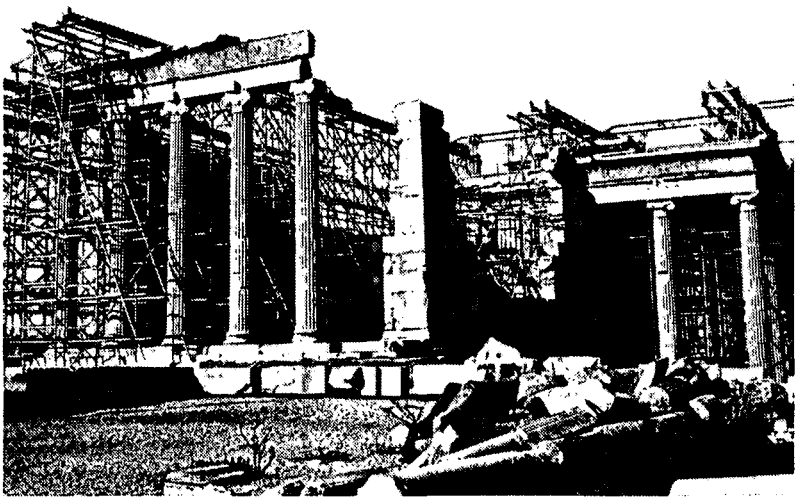

7.6 View from the northeast at the start of the present works



7.7 View of the interior from the east

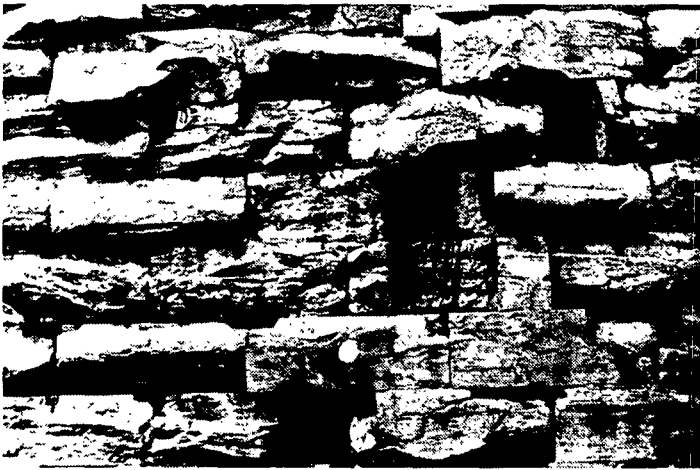

7.8 Detail of the inner face of the south wall

in Figure 7.8. The other most obvious weakness was the loss of the north corner of the east porch.

The real situation was, however, much more serious, chiefly on account of the corrosion of the iron cramps and other reinforcements added in 1902-08 and the resulting damage to the marble, of which examples may be seen in Figures 7.9 and 7.10. A further major cause for concern was the greatly accelerated surface weathering of the caryatids and loss of sculptural detail as a result of the air pollution. This seemed to necessitate their removal to a protected environment.

Damage directly attributable to past earthquakes was slight. It could be seen, for instance, in local fractures near the edges of column drums and bases in the east porch, caused by rocking of the drums on one another. Examples are shown in Figures 7.11 and 7.12.

7.4 Detailed investigations

As one of the major monuments of Classical antiquity, the Erechtheion had already been repeatedly studied and surveyed. There was also available a limited record of the works undertaken in 1902-08. These served as a basis for the further investigation that was necessary before decisions could be reached on the works now desirable.

From the present point of view, the detailed examination and recording of the structural condition, the associated static analyses, and the consideration of the methods to be used for making good local damage and repairing and strengthening the structure as a whole, are the most relevant.

7.4.1 Recording and analysis of the structural condition

A full record was made of the condition of the masonry and the reinforcements. Both visible cracks and internal details were recorded, using gamma radiography for the latter purpose. By this means it was also possible to locate hitherto unsuspected hidden cramps and dowels. See Figure 4.3.

Static analyses were made of the south wall, the west facade, the south porch, and the incomplete east porch. For this purpose, these were considered as independent structural elements, each subject to horizontal wind or earthquake loads as well as gravity loads.

From the analyses it was concluded that:

- there was a risk of overturning of the south wall.
- the stability of the upper part of the west facade could not be guaranteed on account of the manner in which it had previously been reconstructed from many broken blocks and the widespread further cracking caused by the embedded cramps and other reinforcements.
- the iron structure that was intended to relieve the caryatids of load from above was no longer effective in this role.
- replacement of the reinforcements of the reconstructed part of the north porch was also desirable.

7.4.2 Consideration of methods of repair and strengthening

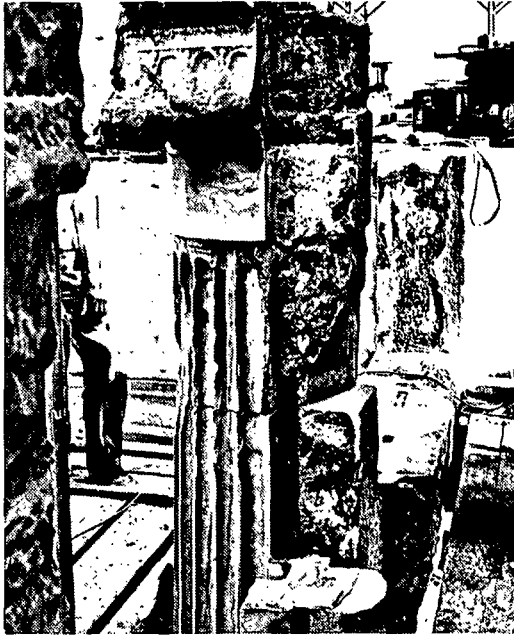

7.9 Fracture of a semicolumn due to rusting of iron reinforcement



7.10 Fracture of an architrave of the north porch due to rusting of hangers



7.11 Fractures on the edges of column drums, east porch



7.12 Fractures at the foot of a column, east porch

The cause of most of the cracking of the marble had been established as swelling of the embedded iron due to corrosion, the corrosion having been accelerated by the inadequate protection given to the iron in the previous restoration, by recent air pollution, and by the greater exposure that resulted from the initial cracking and opening of the bed joints.

The only way of halting the damage was considered to be the removal of the iron and its replacement by a metal with a better performance. The use of titanium was proposed. This is highly non-rusting, has a high mechanical strength, has a coefficient of thermal expansion very close to that of marble, and is not excessively costly for a project of this kind.

To remove the iron, it was of course necessary to dismantle the masonry. But, even after dismantling, a problem remained on account of its swelling. Tests were made with chemical solvents, but a mechanical method was finally selected.

Removal of the caryatids was considered essential until pollution was greatly reduced.

7.4.3 Other investigations

In parallel with these investigations, consideration was given to the architectural, historical, and archaeological factors to be taken into account in deciding of future action. Partial dismantling would, for instance, provide an opportunity for a fuller examination of the individual blocks, and for the restoration to their original positions of some that had previously been moved.

Geological, hydrological, and seismological studies of the Acropolis rock were also undertaken.

7.5 Repair and strengthening

The overall objective was to undertake only such works as were essential to the halting of damage and the preservation of the monument, and to do so in full conformity with the recommendations of the Venice Charter.

Changes should be introduced only where there was clear evidence that they restored the monument to a more authentic state. New stone should be introduced to the minimum extent necessary and where there was adequate evidence of the original form, and it should be clearly distinguishable as new without being needlessly obtrusive. Nothing original should be destroyed. Bearing in mind the mistakes that were unwittingly made in the previous restoration, only materials of proven durability should be used and - in case mistakes were made again - the interventions should be reversible wherever possible for the purpose of rectification.

This was a stringent objective, justified by the unique value of the monument. From the present point of view, the chief interest lies in the way in which it was pursued.

7.5.1 Direction of the work

The whole work, including the investigations already referred to, was undertaken as a national responsibility by the Greek Ministry of Culture and Sciences under the guidance and responsibility of a specially convened

Committee for the Preservation of the Acropolis Monuments.

7.5.2 Preparation of schemes and International Meeting, 1977

On the basis of the detailed investigations, tentative schemes were prepared. Figure 7.13 shows elevations of the north and south walls with all blocks identified for reassembly (where necessary) to the height existing at the commencement of the works. Figure 7.14 shows a scheme for a fuller reconstruction of the north side, including the replacement (if necessary by copies) of the missing corner column of the east porch and the missing epistyle above it. It may be compared with Figure 7.6 showing the existing state. Figures 7.15 to 7.17 show three of the schemes considered for the support of the roof of the south porch.

The proposals were then presented to an international meeting of experts in all relevant fields, sponsored jointly by the Ministry of Culture and Sciences and UNESCO. Only after this was work commenced.

Even then, it was recognised that dismantling would bring to light further evidence of the condition of the damaged masonry and of misplacing of blocks in the previous restoration. It should also permit the identification of the place in the original structure of some of the blocks and fragments still lying on the ground, so that these could be re-incorporated. Final detailed design would, therefore, have to be undertaken later.

7.5.3 Dismantling

All previously restored parts of the north, south, and west facade walls and of the north and south porches were dismantled. Cramps and other metal connections were cut out with fine stone-cutting tools. Hand-driven lifting equipment was used. This had a low operating speed, which allowed checks to be made on the dismantled members during lifting and prevented damage from abrupt movements or vibrations. Members were lifted in suspension belts, with pads inserted between the members and the belts to prevent injuries during fastening. Badly damaged or cracked members were lifted in protective cradles. See also Figure 5.9.

The dismantled members were deposited in prepared locations around the monument. Here, each was fully surveyed, photographed, and documented.

7.5.4 Further archaeological study

On the basis of this documentation and a similar documentation of the blocks and fragments already lying on the ground, the correct locations of the blocks were reassessed and matching fragments were identified. The slightly varying positions of cuttings for the original cramps and dowels in relation to the edges of the blocks were valuable indications of the original relative locations. In the subsequent reassembly, it was thus possible to restore to their correct positions several blocks from the base of the caryatids on the south porch and from the north and south walls.

7.5.5 Repair and strengthening of individual members

The stability of the original structure stemmed from the close bearing of the individual blocks on one another and from their individual capacities to resist the stresses that arose - mainly compressive in the columns and walls, and flexural in the architraves and other spanning elements. It had been weakened largely by damage to the individual blocks which reduced the bearing

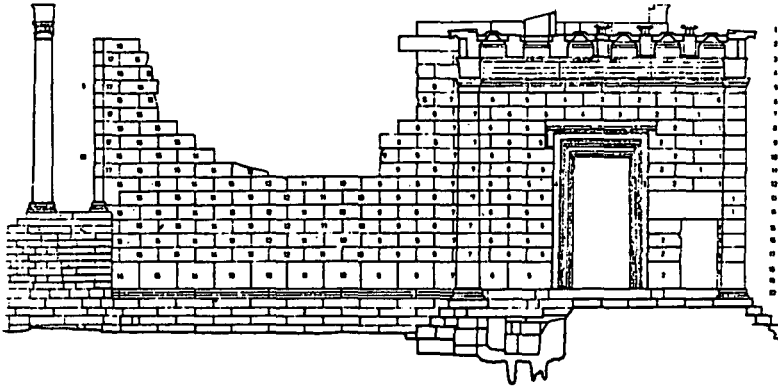

north elevation (1:200)

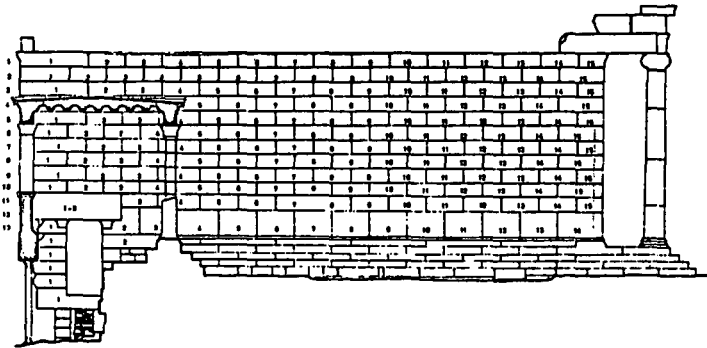

south elevation (1:200)

7.13 Survey drawings

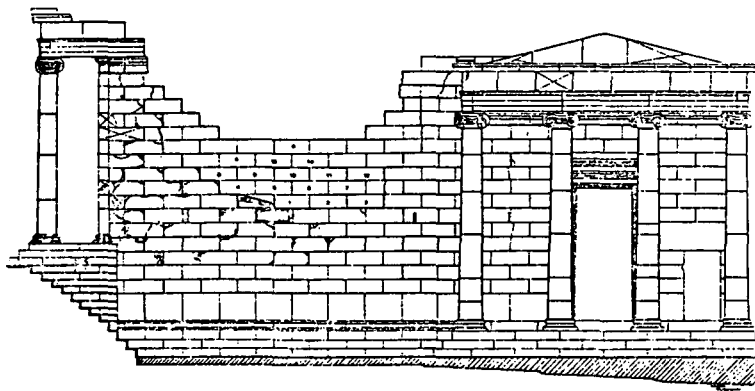

north elevation (1:200)

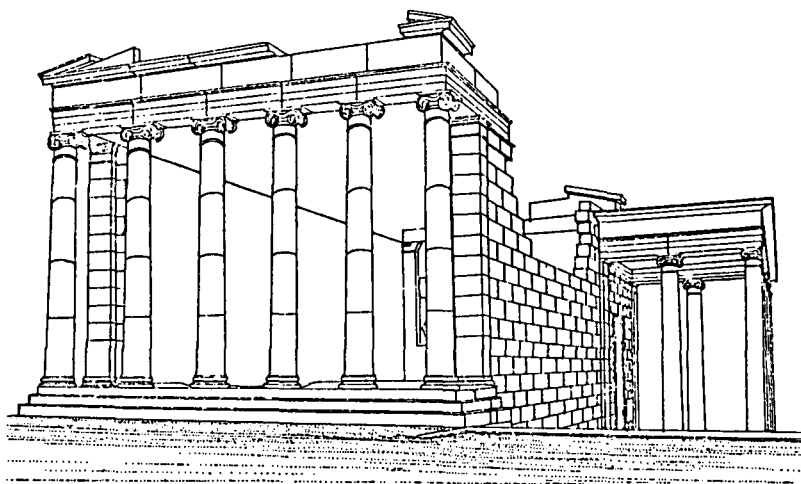

view from the north east

7.14 Proposed reconstruction of the north side

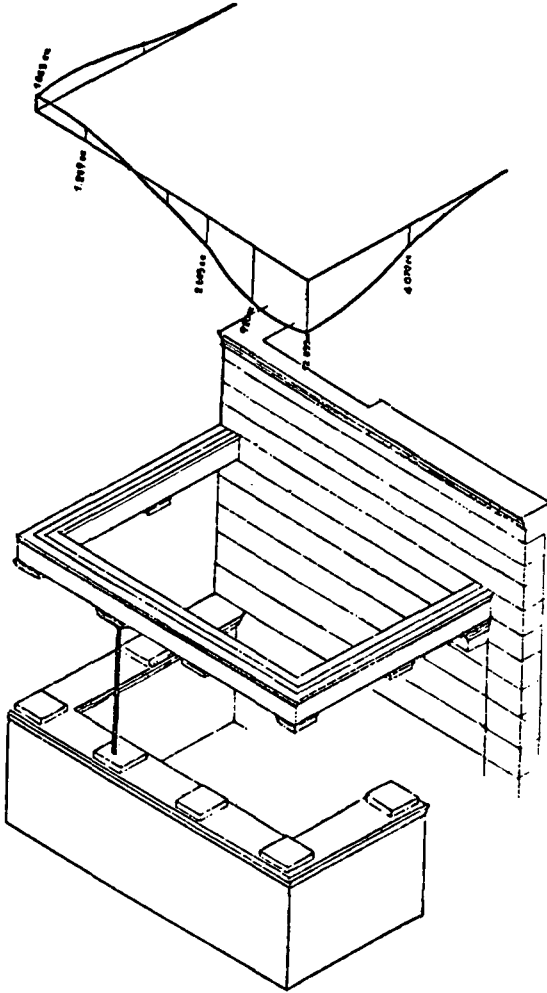

7.15 First proposal for supporting the roof of the south porch (1:100)

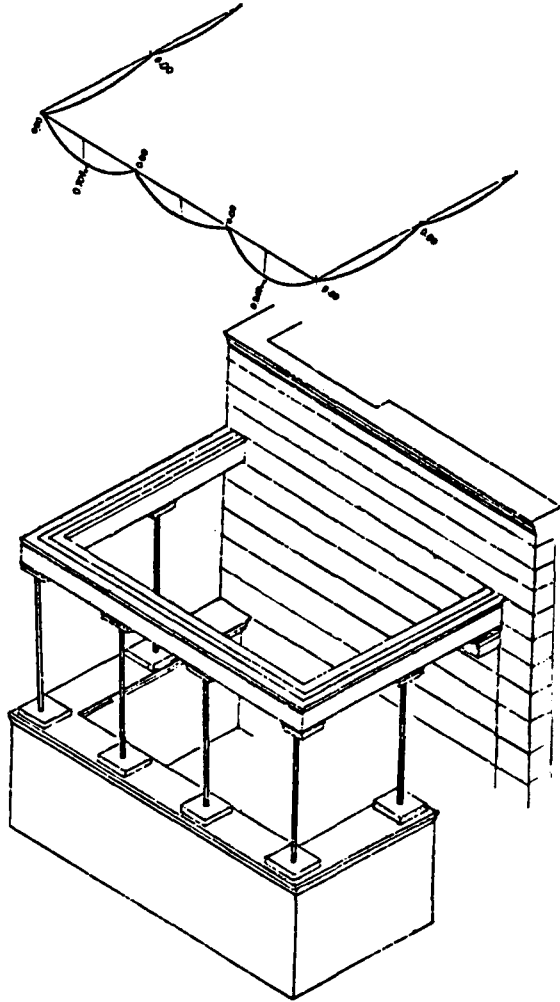

7.16 .Second proposal for supporting the roof of the south porch (1:100)
(as finally selected)

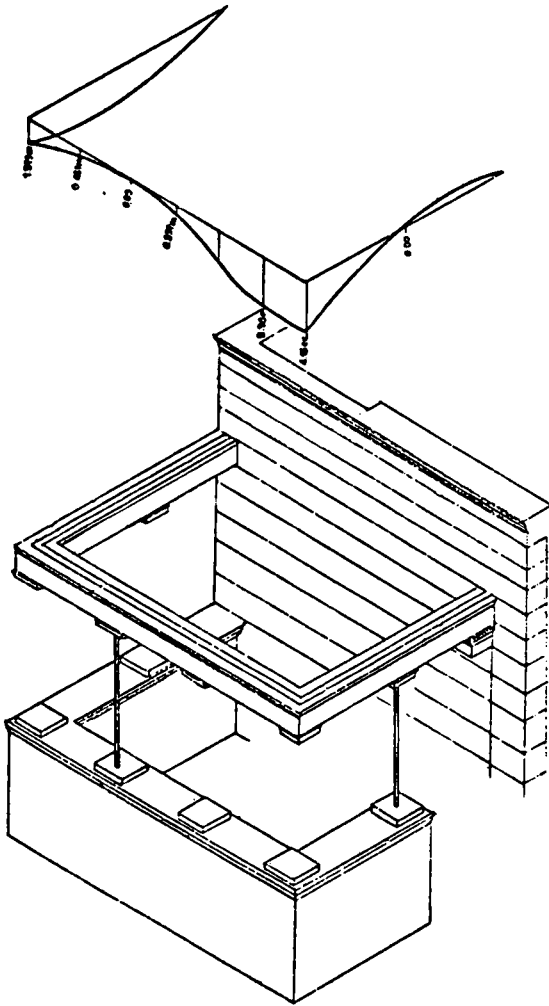

7.17 Third proposal for supporting the roof of the south porch (1:100)

areas and destroyed flexural strengths. The main need for repair and strengthening was therefore for the making good of this local damage, especially where the integrity of the individual blocks was most necessary for overall stability and safety.

Where a part of the original block was missing, it was first necessary to make a new completion piece. In the previous restoration, this operation had been simplified by first cutting into the block as shown in Figure 5.13. This was now considered inadmissible for the reasons given in section 5.4.2. Instead, new completion pieces were cut to fit the untouched face of the break as described in that section and illustrated below and in Figure 5.14, using a similar Pentelic marble.

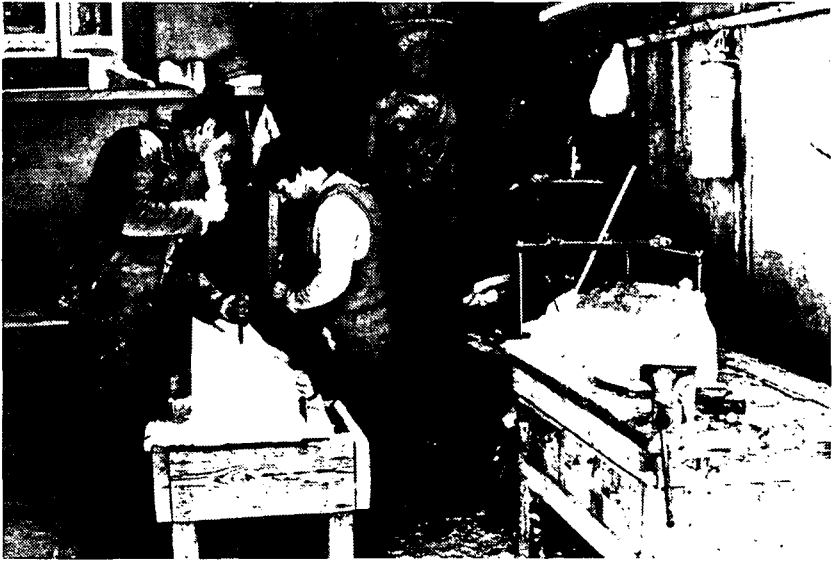

7.18 Cutting a completion piece for a broken block

Where, after reassembly, there would be little tension across the joint, the closely fitting pieces were joined with cement mortar only. Where there would be more tension, titanium bars were inserted as reinforcement, as described in section 5.4.2 and illustrated in Figure 5.15. The reinforcement requirements and necessary bond lengths were determined on the basis of tests in the laboratory.

7.5.6 Reassembly

The process of reassembly closely followed the original erection procedure, except that metal reinforcing beams - now of titanium - were again placed over the main spanning elements of the porch roofs to relieve these of major bending stresses. The marble blocks were set, without mortar, to bear as evenly as possible on one another, and they were connected, as before, by cramps and dowels - now also of titanium. Where possible, these cramps and dowels were placed in the original cuttings, although new cuttings were

sometimes necessary. They were set in a mortar of white sulphate-resistant cement and silica sand.

In the reassembly of the south porch, copies were substituted for the original caryatids which were placed in the nearby Acropolis Museum for protection from the damaging air pollution after possible means of protection in situ had been rejected as unsatisfactory.

7.6 Sources

7.6.1 Sources for the text

The principal source was the Greek input report, 1982, part 1:

- Zambas, C, 'Articulated Ancient Greek and Roman buildings: General identification of structural characteristics, damage and strength assessment and intervention methodologies'.

This was supplemented by inspections of the works with Mr Zambas, further notes prepared by him, and by reference to the following:

- Andronopoulos, B, and Koukis, G, Engineering geology study in the Acropolis area - Athens, Institute of Geological and Mining Research, Athens, 1976.
- Balanos, N M, Les monuments de l'Acropole, Paris, 1938.
- Ministry of Culture and Science, The Acropolis, Athens, 1976.
- Ministry of culture and Sciences and UNESCO, International meeting on the restoration of the Erechtheion, Athens 1977. (reports by S. Angelidis, Ch Bouras, and Th Skoulikidis and associated groups of civil engineers, architects and archaeologists, and chemical engineers)
- Paton, J M, and Stevens, G P, The Erechtheum, Cambridge, Mass., 1927.

7.6.2 Sources for the illustrations

The illustrations are taken from photographs and drawings supplied by Mr Zambas from the archive of the Committee for the Preservation of the Acropolis Monuments, except for the following:

- Figure 7.1: J Travlos, Athens.
- Figures 7.2, 7.3, 7.5: from G P Stevens, The Erechtheum, op. cit.

8. CASE STUDY: THE ROTUNDA, THESSALONIKI

8.1 Introduction

The Rotunda suffered serious damage in the earthquake of June 1978. Since it is comparable in importance - as one of the chief surviving monuments of the late Roman Empire in the whole Balkan region - with the Erechtheion, a major programme of research was undertaken to provide the data required for the subsequent repair and strengthening. The present study focusses on this research.

It is not suggested that investigations on this scale will often be required or justified. But it may be noted that a similar overall procedure was followed in dealing with other monuments damaged in the same earthquake, as is illustrated by the following study of Hagios Andreas, Peristera.

8.2 Description

The Rotunda was built close to, and as a part of, the Imperial Palace in about 300 AD. It was an imposing circular building resembling the Pantheon in Rome and covered by a huge dome 24.5 m in diameter. The chief difference (apart from the smaller size) was that the construction techniques were those typical of this part of the Eastern Empire rather than those of early 2nd century Rome. Eight barrel-vaulted niches lightened the 6.25 m thick walls.

The original structure has survived substantially intact, as shown below and in Figures 8.2 and 8.3, although it has undergone a number of adaptations.

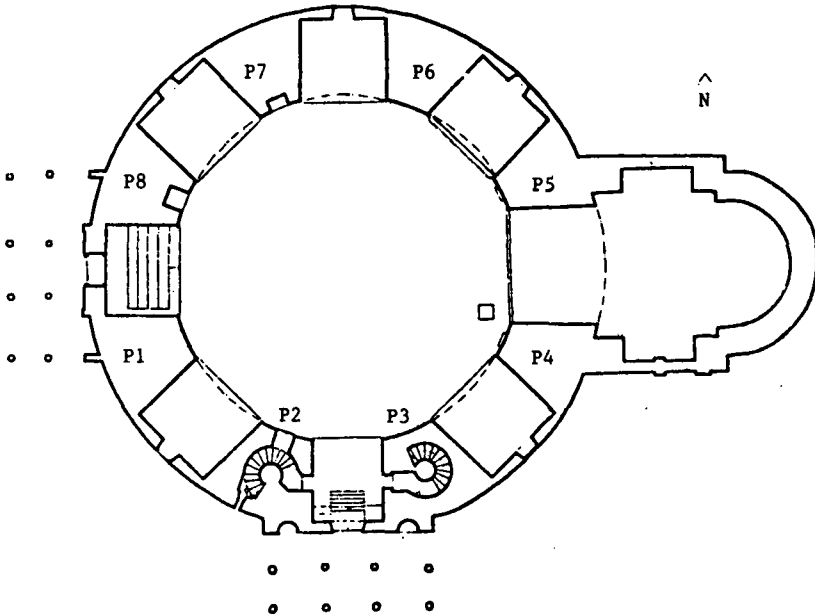

8.1 Plan at ground level (1:400)

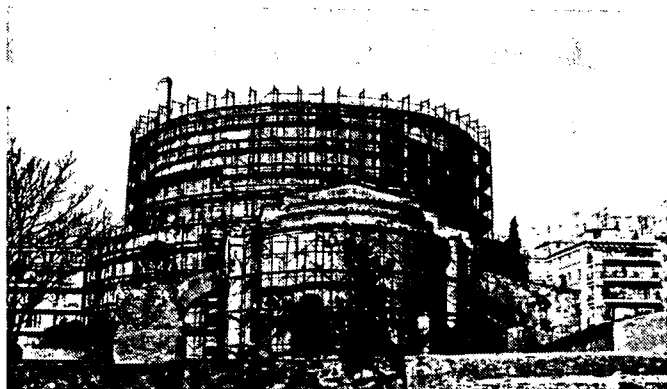

8.2 View from the east

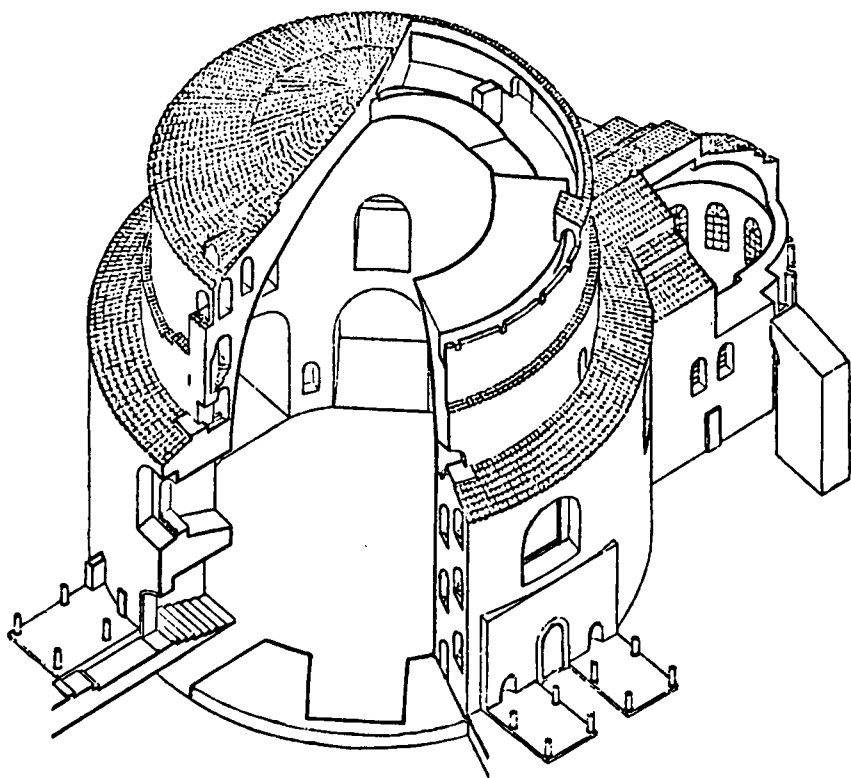

8.3 Cut-away isometric view from the southwest (1:400)

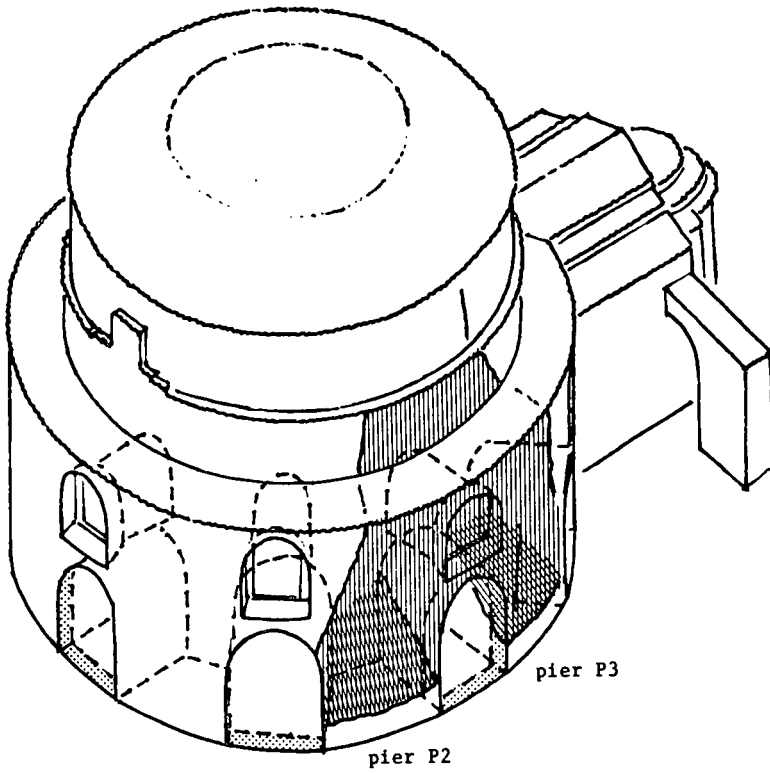

8.4 The main sliding cracks on the southern piers P2 and P3

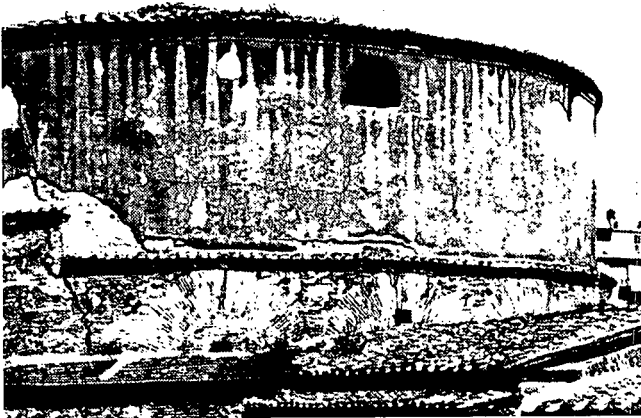

8.5 Cracking of the dome base from the southeast

Having been built as a mausoleum or throne room, it was first adapted in about 400 AD for use as a church. A vaulted chancel and apse and an ambulatory were added. The walls of the niches were pierced to give access to the ambulatory, and the main cylindrical wall was cut further at the east to open the interior to the new chancel. This last intervention seems to have led to a partial collapse of the dome and its subsequent reconstruction. The dome was given a mosaic decoration of saints standing against an architectural background, which still largely survives.

Later, the ambulatory was damaged, perhaps partly by earthquakes. When, during the Ottoman occupation, the church became, in turn, a mosque, it was removed. At this time the pierced walls of the niches were again closed, and a minaret, which still stands nearby, was added.

8.3 Structural condition

Before the earthquake of June 1978, the structure was already extensively cracked, especially in the piers (P2 and P3 in Figure 8.1) which flank the southern entrance and which were already weakened by the helical staircases within them. The inclined cracks in these piers appear to have had a width of about 120 mm, as indicated by fillings of tiles and mortar probably dating from the beginning of this century.

Concern about the poor structural condition was expressed in several reports from 1976 onwards, but no action had been taken when the earthquake caused a further worsening, including further opening of the cracks. Most seriously, it appeared that the part of the structure bounded by the cracks in piers P2 and P3 had then begun to slide.

The condition after the earthquake is described more fully in the following paragraphs.

8.3.1 The southern piers P2 and P3

The cracks in these piers extended over the full height of the monument. As seen in Figure 8.4, they ran almost vertically up the outer surface, and they continued, where visible, through the thickness of the piers at an angle of about 70° to the horizontal.

8.3.2 The north-western pier at the left of the western entrance

This pier had a vertical crack near the middle, which extended on both outer and inner faces up to the springing level of the dome.

8.3.3 The dome

This was cracked radially in its lower part in the manner that was to be expected from the cracking and associated outward inclinations of the piers. One crack can be seen on the left of Figure 8.5, where the surface rendering has fallen away.

8.3.4 The walls and vaults of the Christian chancel and apse

These were also cracked, with associated outward inclinations of the walls.

8.4 Emergency works

Because of the apparently serious structural condition after the earthquake, and to permit systematic further investigation and full consideration of a scheme for final repair and strengthening, emergency works were undertaken as follows:

- erection of heavy timber shores between piers P1 and P2, P2 and P3, and P3 and P4, to support the load from the dome directed towards piers P2 and P3.
- erection of shores on all sides of piers P2 and P3 (as seen in Figure 5.1) to prevent their collapse.
- internal cross bracing with heavy timber of the helical stair openings in piers P2 and P3.
- installation of prestressed external rings of 26 mm diameter mild steel bars (as seen in Figure 8.6) to assist further in preventing continued outward movement of piers P2 and P3.
- support of the chancel vault by metal frames.
- shoring of the south porch.
- erection of steel scaffolds both inside and outside (as seen in Figure 8.2) to give access for detailed measurements and, later, for final repair and strengthening.

8.5 Detailed investigations

The extensive investigations that were then commenced progressed from architectural and constructional surveys and other in-situ surveys and measurements to laboratory tests and analyses of the existing stability of the structure. These investigations aimed not only to assess the need for repair and strengthening, but also to permit choices of materials and methods that were appropriate to the character of the monument and its historical importance.

8.5.1 Architectural and constructional surveys

A precise architectural survey was made using standard survey techniques including photogrammetry. To determine the foundation conditions, four sections were cut to base level. One is reproduced in Figure 8.7. Ten further cuts were made to determine the thicknesses and construction of the dome and the vaults of the Christian chancel and apse. Other details of the construction were determined (or inferred) from observations of the visible surfaces and comparisons with contemporary part-ruined structures, such as the Palace octagon in the Hippodrome, where similar masonry could be seen on the outer faces.

8.5.2 Survey and recording of the damage

An initial survey was made of the lines of all cracks as visible at the surfaces of the masonry, both by measurement and photographically. Crack widths and depths (where ascertainable) and relative displacements of the edges (both tangential and normal to the surface of the masonry) were all recorded.

Subsequent movements at the cracks were then recorded by means of suitable



8.6 Prestressing of temporary external steel rings

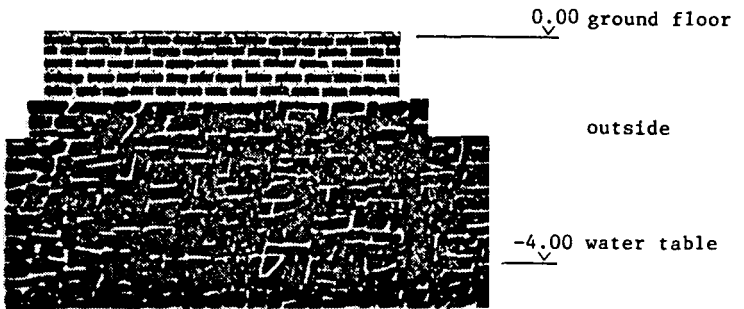

8.7 Vertical section of the Roman foundation (1:100)

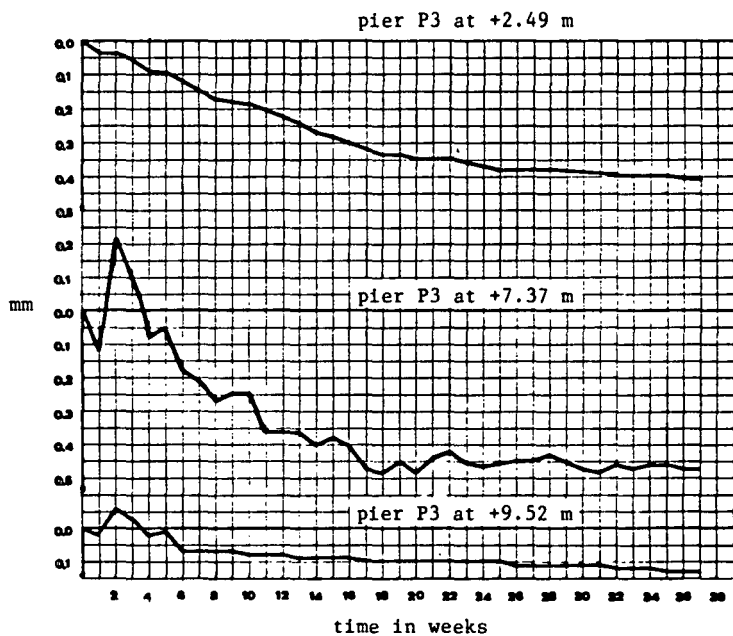

8.8 Variation of crack widths with time

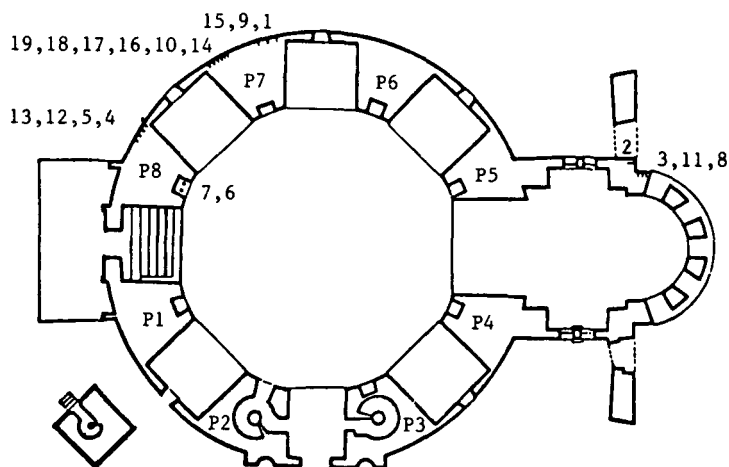

8.9 Locations for taking cores

gauges installed at 11 critical positions. Typical records are reproduced in Figure 8.8. These continued measurements served both to indicate any worsening in the structural condition and as a control on the effectiveness of the strengthening measures.

The survey also included measurements, at several levels, of the deviation of the piers from the vertical.

To give a more comprehensible overall picture of the damage, the cracks were marked on the transparent plexiglass model of the structure to a scale of 1:100 that is illustrated in Figure 4.1. Here it was possible to show clearly how cracks visible on the outside related to those inside.

8.5.3 Tests on materials

Tests were made both in situ and in the laboratory to determine the mechanical properties of the materials, and further laboratory tests were made to determine the chemical compositions to assist in the choice of suitable grouts.

For the laboratory tests, 19 cores of 100 mm diameter were taken from various locations as indicated in Figure 8.9. From these cores, specimens of the mortars, of the bricks, and of brick-plus-mortar were prepared for the determination of the compressive and flexural strengths and moduli of elasticity of the mortars, the compressive strengths and moduli of elasticity of the bricks, and the bond strengths between bricks and mortar. Values of compressive strength of the mortar obtained from these tests are given below.

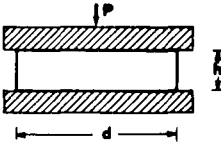
Period	Core No	Specimen No	b (cm)	d (cm)	Failing Load (Kg)	Strength (Kg/cm ²)
Roman	5	1	3,03	7,40	510,00	22,75
	9	2	3,00	3,80	170,00	14,91
	12	3	4,40	9,35	570,00	13,86
	14	4	4,93	9,18	890,00	19,66
	16	5	4,10	4,80	330,00	16,77
	18	6	4,40	8,70	815,00	21,29
	18	7	4,30	6,56	700,00	24,82
	19	8	4,10	9,10	740,00	19,83
	19	9	4,10	6,90	580,00	20,50
Christian	3	1	4,08	6,02	815,00	33,18
	3	2	4,03	6,66	1085,00	40,43
	3	3	3,90	4,16	835,00	51,47
	3	4	3,64	6,10	1110,00	50,00
	3	5	3,60	5,57	1115,00	55,61
	3	6	3,55	4,00	880,00	61,97
	8	7	3,90	7,50	1650,00	56,41
	8	8	4,15	7,50	1200,00	38,55
	8	9	3,50	6,90	600,00	24,84
	8	10	3,58	4,55	735,00	45,12
	8	11	3,50	6,09	950,00	44,57
	8	12	3,58	7,38	910,00	34,44

Table I Laboratory tests of compressive strength of the mortar

To obtain truly credible values of the properties for the whole structure would, of course, have necessitated many more specimens from other locations if reliance had been placed wholly on such tests. Since it was not desired to cause further damage to the monument, the laboratory tests were supplemented by non-destructive ultrasonic and hammer tests. 600 hammer tests and 300 ultrasonic measurements were made over the whole external and internal surfaces.

Very satisfactory correlation was obtained between the hammer test results and the corresponding measurements of compressive strengths in the laboratory (correlation ratio of 0.867). Using the laboratory measurements to calibrate the hammer test results, a statistical evaluation of the mortar strengths was made, as shown in the following Table.

Constr. Phase	Location of Tests	Number of Tests	Mean value	Standard deviation	Lower 5% fractile	Upper 5% fractile	Minimum value	Maximum value
			μ	σ	$\mu-1,645\sigma$	$\mu+1,645\sigma$		
			(kg/cm ²)	(kg/cm ²)	(kg/cm ²)	(kg/cm ²)	(kg/cm ²)	(kg/cm ²)
Roman	P1	54	28,33	4,61	20,75	35,91	17,80	39,40
	P2	54	29,96	6,91	18,59	41,33	19,19	44,94
	P3	54	26,04	5,54	16,92	35,16	15,16	42,93
	P4	54	32,36	5,89	22,67	42,05	15,16	42,93
	P5	54	29,67	6,64	18,75	40,59	15,16	49,08
	P6	54	28,23	6,35	17,78	38,68	17,13	39,99
	P7	54	28,13	6,44	17,54	38,72	13,90	39,04
	P8	54	27,34	7,57	14,89	39,79	11,51	48,03
	Top	144	32,44	6,34	22,01	42,87	15,16	49,08
	Midnight	144	28,27	5,04	19,98	36,56	17,80	39,04
	Bottom	144	25,56	6,13	15,48	35,64	11,51	42,93
Inside	216	27,36	5,25	18,72	36,00	15,16	42,93	
Outside	216	30,16	7,29	18,16	42,16	11,51	49,08	
Total	432	28,76	6,50	18,07	39,45	11,51	49,08	
Christian	Top	54	36,96	11,60	17,87	56,05	15,81	60,16
	Midnight	54	37,39	11,15	19,05	55,73	19,19	59,00
	Bottom	60	39,88	14,32	16,33	63,43	13,90	69,77
	Inside	72	33,91	11,25	15,40	52,42	13,90	59,00
	Outside	96	41,32	12,51	20,74	61,90	15,81	69,77
	Total	168	38,14	12,50	17,57	58,71	13,90	69,77

Table II Hammer tests of compressive strength of the mortar

It will be seen from this evaluation that:

- the mean strength of the mortar in the Christian part is considerably higher than in the Roman part, although it also has a more than proportionately higher variability.
- the lowest strengths are found at the bottom of the monument, possibly because of deterioration due to ground water.

The compressive strength and modulus of elasticity of the compound masonry were determined from the separate strengths and moduli of bricks and mortar, using the semi-empirical relationships given in current Codes of Practice.

Chemical analyses were made as follows on specimens taken from the 19 cores:

- determination of the proportions of paste and aggregate in the mortar.
- determination of the hydraulic constituents of the mortar, including the quantitative determination and the identification of the source - i.e. pozzolanic ash or crushed brick. Results from core 10 in the Roman part of the monument are tabulated below.
- determination of the composition of the bricks, including a comparison with that of the brick dust in the mortar and a determination of the hydraulic properties.

Composition	First analysis with coarse ceramic material			Second Analysis without coarse ceramic material		
	Determined values			Determined values		
	(gr)	%	%	(gr)	%	%
Burning loss	2.672	12.78		4.3045	21.52	
Insoluble compounds	13.852	66.30		8.989	44.94	
Soluble compounds	(4.372)	(20.92)	Composition of compounds	(6.71)	(33.54)	Composition of compounds
SiO ₂	0.540	2.58	12.35	0.640	3.20	9.53
R ₂ O ₃	0.673	3.22	15.39	0.775	3.87	11.55
CaO	2.988	14.31	68.36	5.10	25.48	76.00
MgO	0.107	0.51	2.44	0.1175	0.59	1.75
SO ₃	0.029	0.14	0.67	0.029	0.14	0.44
Na ₂ O	-	-	-	0.0060	0.03	0.09
K ₂ O	-	-	-	0.0400	0.20	0.59
Not determined	0.035	0.16	0.79	0.0025	0.03	0.05
Total	20.896	100.00	100.00	20.003	100.00	100.00

Table III Chemical composition of the Roman mortar

In parallel with these chemical analyses, analyses were also made of materials from other sources that it was thought might be suitable for preparing grouts - i.e. hydrated lime, pozzolanic ash, cement, and powdered brick.

8.5.4 Tests on soils

Data on the soils on which the monument stood were necessary for the estimation of seismic base shears. These tests also served to confirm that the soil conditions exerted no unfavourable influence.

Four borings were made to a depth of 25 m. The soil profile and water table were determined, and the usual tests were made on the soil samples for

liquid and plastic limits, strength in unconfined compression, particle size distribution, etc. Standard penetration tests were also made.

8.5.5 Determination of natural periods, damping, and ductility

Natural periods of vibration were calculated by the Rayleigh method for the two models of the structure shown below. One was a free cantilever pier. The other was a series of free cantilevers connected by a ring at mid height and vibrating radially and simultaneously.

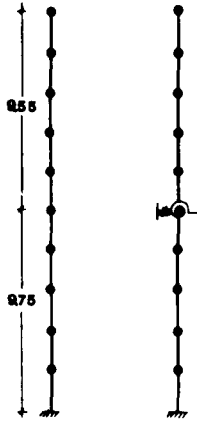

8.10 Analytical models for determining natural periods of vibration

Records were also made of ambient vibrations and good agreement was obtained between the periods obtained from these and the calculated periods. Typical records are reproduced in Figure 8.11.

It was considered unwise to undertake forced vibration tests before the structure had been repaired and strengthened. Damping was therefore estimated from data on other structures.

The relevant ductility factor for estimating the seismic loading was the one that was associated with outward rotations of the piers. This was determined both for free cantilever action and for analytical models in which rotation of the piers was restrained by prestressed rings of various types of steel at the levels of the rings installed in the emergency works. The calculated load-deflection curves are reproduced in Figure 8.12

8.5.6 Estimation of seismic loading

Using the above data on soils, natural period, damping and ductility, and taking into account the importance of the monument, the seismic loading was estimated according to the Greek NCAP Code (in preparation at the time), the SEAOC Code, and the response spectrum derived from the accelerogram of the 1978 Thessaloniki earthquake.

8.5.7 Static analyses of the Roman part of the structure

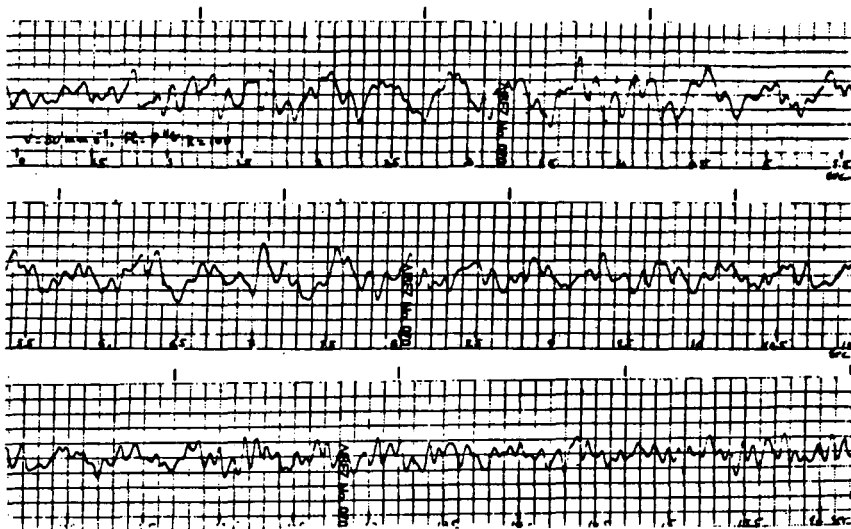

8.11 Records of ambient vibrations

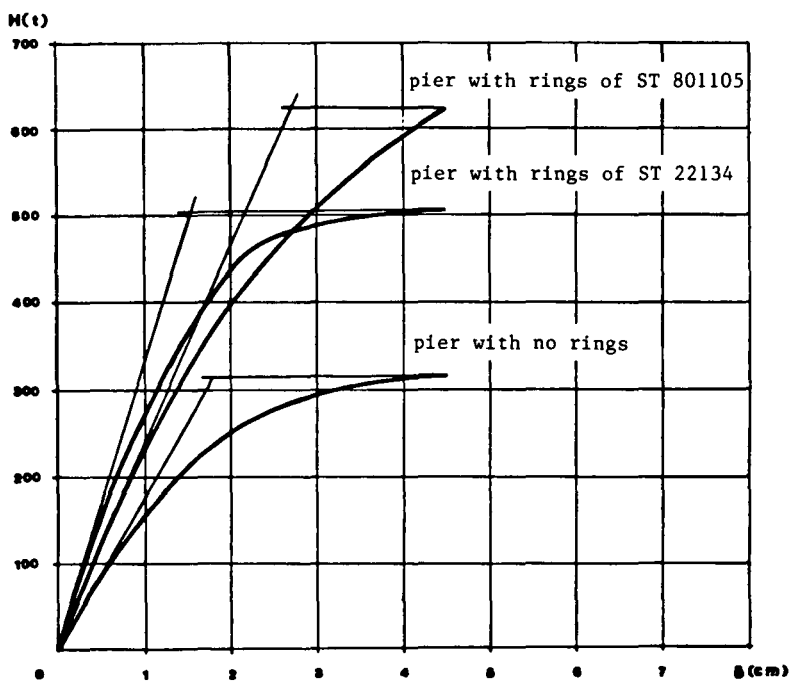

8.12 Calculated curves of load v horizontal deflection for the piers

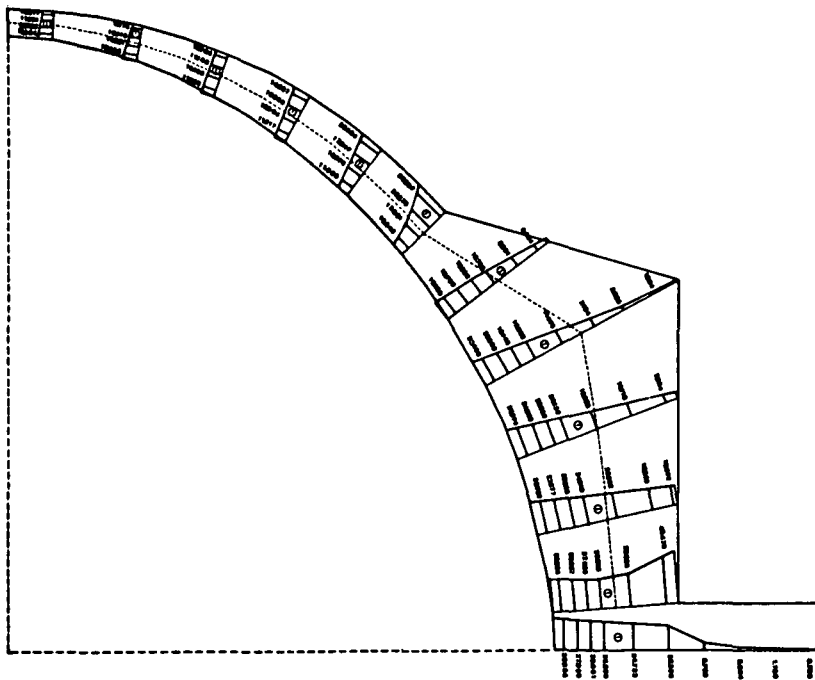

8.13 Calculated distribution of meridional stresses in the dome

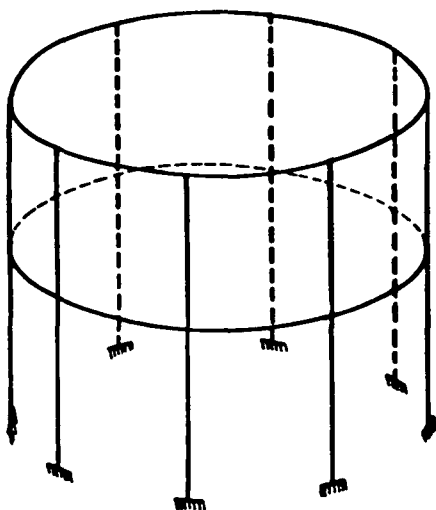

8.14 Frame model of the dome support system

Initially several elastic analyses were made for:

- vertical gravity loading.
- independent ring-type loadings at three levels where there was a possibility of installing permanent peripheral prestressed rings.
- horizontal seismic loading.

The structure as a whole was analysed first, using an axi-symmetric finite-element model. The presence of the niches in the cylindrical lower part of the structure was allowed for by introducing a reduced effective modulus of elasticity there. Stresses in the dome, as calculated in one of these analyses, are plotted in Figure 8.13.

The support system for the dome was then analysed as the linear-element space frame shown in Figure 8.14. For this purpose the forces at the junction of the dome and the supports were taken from the previous analysis, except in the case of horizontal seismic loading. In that case, because of their relative unimportance, they were estimated by simpler membrane theory. This analysis was performed both for the initial state of the structure with an uninterrupted supporting ring at the intermediate level at the east, and for the later state with the ring cut here to give access over its full height to the Christian chancel.

Elastic analyses can, however, provide only conservative estimates of collapse loads. Both for this reason, and because such analyses are of questionable validity when the structure is already extensively cracked, ultimate load analyses were also made.

Application of the upper and lower bound theorems led to the conclusion that the collapse mechanism would involve interruption of the continuity of the rings of masonry linking the piers and the formation of hinges at the top and bottom of the piers. Ultimate loads were therefore calculated for the piers acting as free cantilevers.

Since failure was possible in shear as well as by rotation, it was necessary to establish failure criteria for the masonry in combined compression and shear. The tests referred to in section 8.5.3 gave directly only the uniaxial compressive strength and the bond strength between bricks and mortar. Uniaxial tensile strength was given indirectly by the bending strength. An envelope of ultimate strength in combined shear and compression was therefore obtained on the analogy of the curves for low-strength concretes having similar compressive and tensile strengths, as shown in Figure 8.15.

8.5.8 Conclusions for the Roman part of the structure

From these analyses, the following conclusions were drawn about the structural behaviour and safety of the structure at different times:

- as first constructed, all members had a safety factor under gravity load within the range of about 2.70 to 3.10. Thus they had fairly uniform strength at all critical points, similar to that which would be provided today for masonry construction.
- under seismic-plus-gravity load, however, ruptures of the upper and lower rings between the piers were already possible and may have occurred in this initial state.

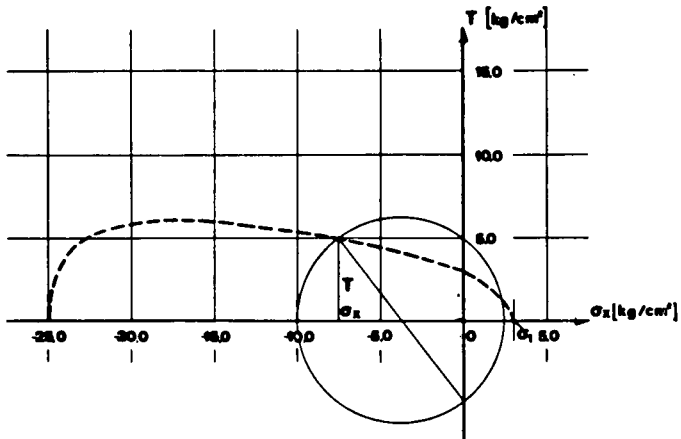

8.15 Strength of the masonry in combined shear and compression

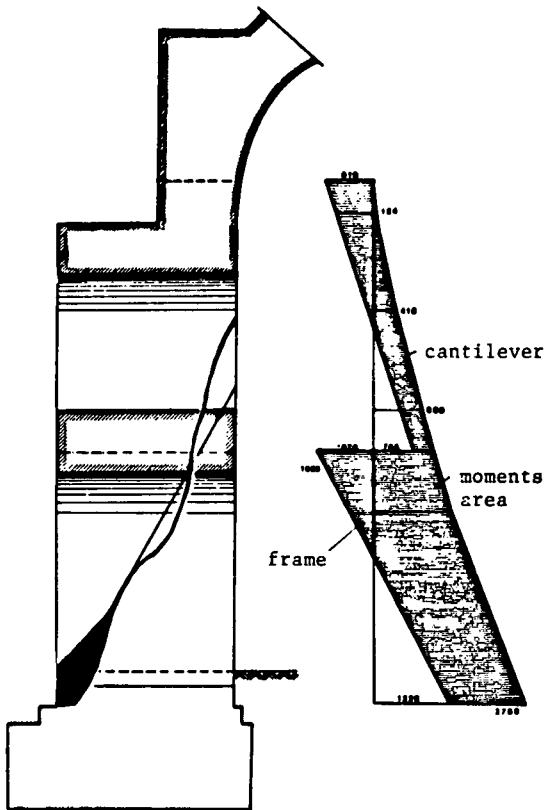

8.16 Cracked pier with staircase

- after the cutting of the intermediate ring at the east for the Christian chancel, a rupture of the upper ring was possible even under gravity load if it had not already occurred, and this could have led to a partial collapse of the dome.
- additional seismic load at this stage would certainly have caused rupture of the upper ring.

The Christian modification critically reduced to load-bearing capacity, and it is certain that, at least after the next strong earthquake, the piers would have had to act as free cantilevers. Thus the subsequent behaviour need only be considered on this basis. The following further conclusions were drawn about them when so acting:

- gravity load could be safely carried with a safety factor of about 2.15.
- under gravity-plus-seismic load, piers P2 and P3 should fail in shear by a crack inclined at 61° to the horizontal for a base shear with a lower bound of about 8.5% of the gravity load. As may be seen from Figure 8.16, this calculated crack inclination agreed closely with the measured inclinations of the observed cracks in these piers. The remaining piers (which are not weakened by internal stairs) should safely withstand a base shear about 70% greater. This is consistent with their observed lack of damage.
- failure of piers P2 and P3 activated the sections of infill wall of the flanking niches, and these prevented complete collapse of the piers by raising the combined seismic shear resistance to about 14% of the gravity load.
- the addition of the temporary prestressed rings significantly improved the safety margins.

Calculated stresses in the foundation and the resulting deformations were well within safe limits throughout the lifetime of the structure. Since the addition of the circumferential prestress improved safety, there was no need for further checking of the foundation.

8.5.9 Static analysis and conclusions for the Christian chancel and apse

An initial ultimate load analysis of the chancel, following the step-by-step graphical procedure illustrated in Figure 9.3 and described in the accompanying case study, indicated a factor of safety of about 67% for gravity load alone. It seemed unlikely that the apse would add sufficiently to the total strength to prevent collapse, even without an earthquake. This suggested either that the flying buttresses were erected at the same time as the chancel, or that the present heavy covering of the vault seen in Figure 8.17 is a latter addition and that the buttresses were added when the addition was made.

A further analysis was made in which the flying buttresses were included. This still indicated a low factor of safety of about 1.20 for gravity load alone.

No analysis was made for seismic load, since any analysis for horizontal load which did not include the stabilising contribution of the adjacent Roman part would have been unrealistic.

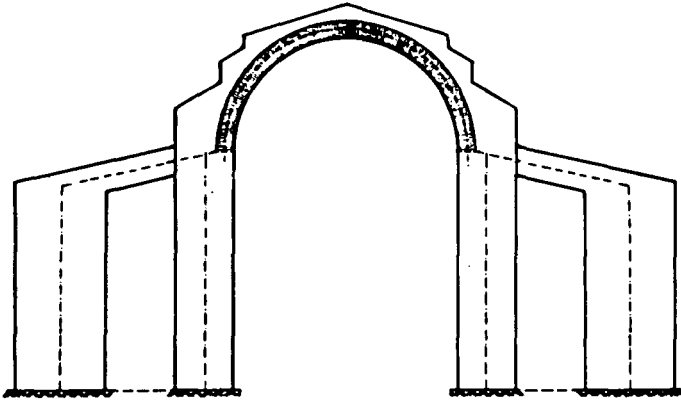

8.17 Cross section of the Christian chancel (1:250)

8.6 Repair and strengthening

Proposals for repair and strengthening had to meet the following requirements:

- repairs should be clearly distinguishable from original work so that the authenticity of the latter would not be placed in doubt.
- interventions should, where possible, be reversible to permit the adoption of improved procedures at a later date if this then seemed to be desirable.
- where reversible procedures were impracticable, the materials used should be fully compatible with the original materials and should be of known long-term durability.

8.6.1 Proposals for the Roman part

On the basis of the analyses described above, local repair and strengthening of piers P2 and P3 was considered necessary, plus more general repair and strengthening by internal grouting and the installation of permanent peripheral prestressed rings.

For the local repair and strengthening of piers P2 and P3, the following were proposed:

- the application of an internal reinforced concrete (gunite) skin to each helical stairway, as shown in Figure 8.18b, using as reinforcement high-strength deformed bars of an austenitic stainless steel alloyed with chromium, nickel, and molybdenum.
- the stitching of the piers throughout their height as shown in Figures 8.18a and 8.19, using prestressed bars of the same steel, protected by means of a cement grout of high alkali content. (Prestressing steels were not used because there would have been difficulty in providing adequate anchorage within the masonry.)

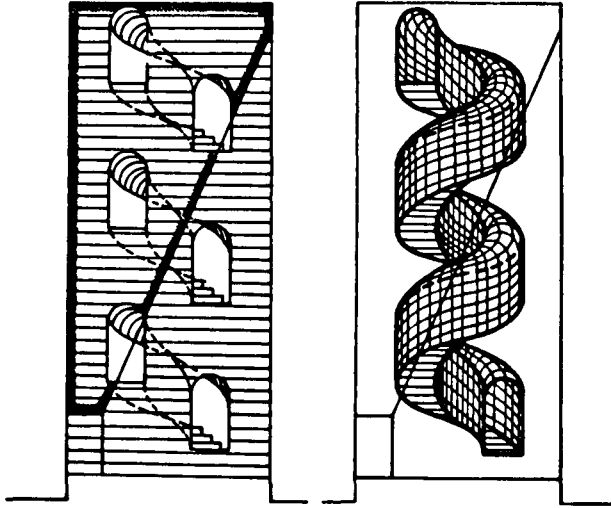

8.18 Reinforcement of piers P2 and P3 (diagrammatic)

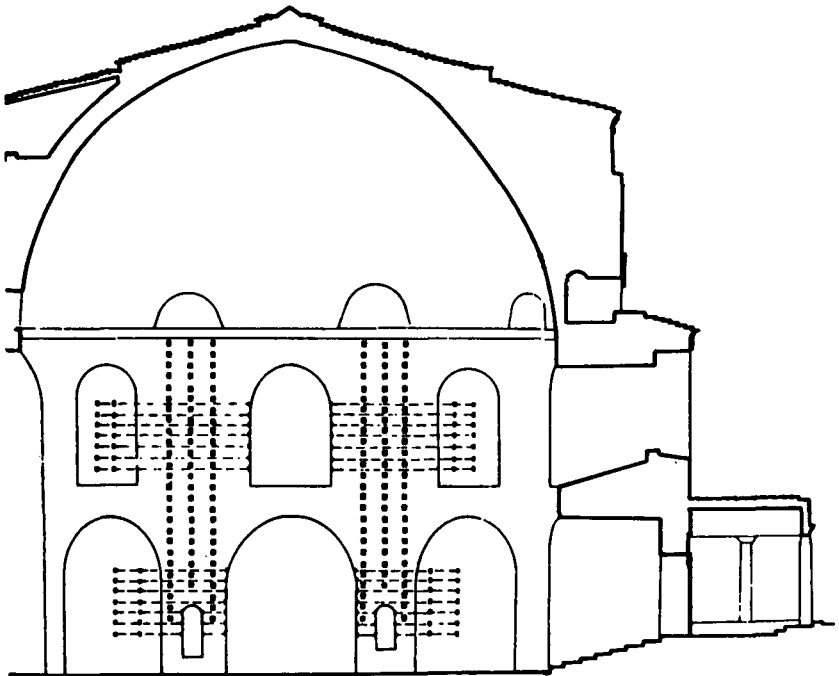

8.19 Internal elevation of reinforcement of piers P2 and P3 (1:250)

For the more general repair and strengthening the proposals, in more detail, were as follows:

- the grouting of all cracks in the piers.
- the installation of permanent mild steel (ST 37) rings on the external face of the monument as shown in Figures 5.25 and 8.20. These rings should be protected by a lead coating. (This would be a reversible intervention, and mild steel was proposed because it would give greater ductility and because the age of the structure limited the risk of relaxation due to creep of the masonry.)
- the initial stressing of these rings to 50% of the final prestress, with the simultaneous removal of the temporary rings.
- the grouting of all radial cracks in the upper and intermediate masonry rings.
- the final stressing of the mild steel rings.

8.6.2 Selection of a suitable grout

Grouting is an irreversible intervention. This was considered to rule out the use of organic resins whose long-term behaviour is unknown, and to favour

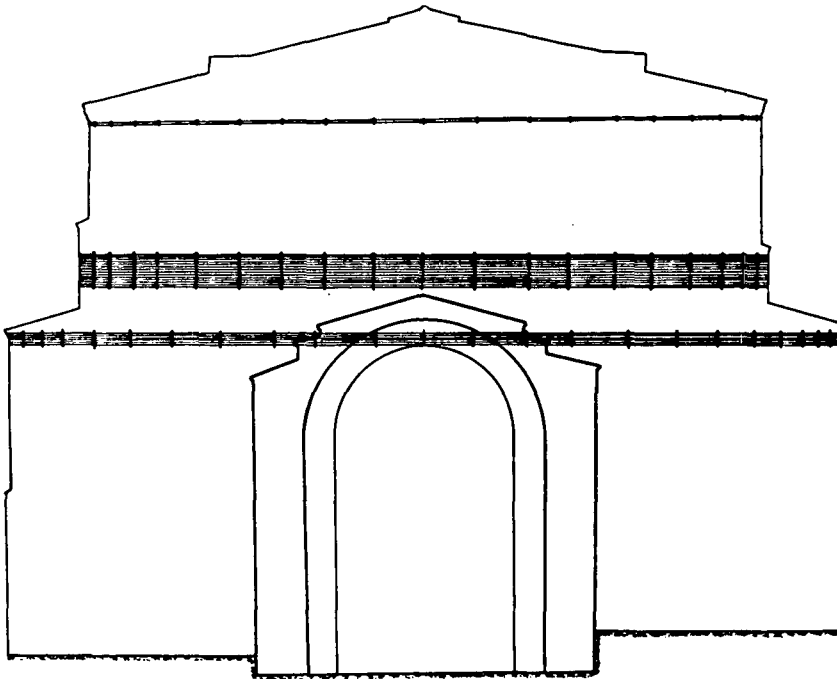

8.20 External elevation of permanent prestressed tie rings (1:250)

the use of traditional inorganic materials whose durability was proven in the monument itself. Similar requirements arose for the repair and strengthening of other monuments in Thessaloniki. A whole series of mixes was therefore tested to provide a basis for selecting the most suitable ones for each monument in accordance with the desirable strengths and moduli of elasticity and the current specifications for fluidity, bleeding, shrinkage, and sedimentation.

In the first stage of the test programme, the grouts were mixed from hydrated lime and powdered brick, or from hydrated lime, powdered brick, and pozzolanic ash. Although the powdered brick in the Roman mortar had given it good hydraulic properties, the results now with powdered brick were unsatisfactory. The final mixes to be tested were therefore of pozzolanic ash, hydrated lime, and cement, in ratios varying from 10:5:1 to 10:5:10, and of pozzolanic ash, hydrated lime, cement, and fine sand, in ratios varying from 10:5:1:16 to 10:5:10:15. They are listed below.

Grouting		Mixing Proportions (parts by weight)								Sinking
Category	Label	Pozzo- lanic Ash	Lime	Cement	Ceramic powder 900°	Ceramic powder 650°	Sand	Water	Tricosal	time (sec.)
I	E ₁	10	5	-	-	-	-	15,50	-	33
	E ₁	10	5	-	-	-	-	12,00	0,15	30
	E ₂	10	8	-	-	-	-	12,50	0,18	32
	EN ₂	6	4	-	5	-	-	13,50	0,15	28
	EN ₄	6	4	-	-	5	-	14,50	0,15	29
	K ₁₋₁	10	5	-	-	-	15	17,50	0,15	28
	K ₁₋₂	10	5	-	-	-	30	18,75	0,15	26
K ₁₋₃	10	5	-	-	-	45	20,50	0,15	27	
II	ET ₁	10	5	1	-	-	-	12,50	0,16	32
	ET ₂	10	5	2	-	-	-	12,50	0,17	34
	ET ₃	10	5	3	-	-	-	12,75	0,18	34
	ET ₄	10	5	4	-	-	-	14,00	0,19	28
	ET ₅	10	5	5	-	-	-	14,50	0,20	30
	ET ₆	10	5	6	-	-	-	14,00	0,21	32
	ET ₇	10	5	7	-	-	-	15,00	0,22	30
	ET ₈	10	5	8	-	-	-	15,50	0,23	33
	ET ₉	10	5	9	-	-	-	16,00	0,24	31
	ET ₁₀	10	5	10	-	-	-	16,50	0,25	30
III	KT ₁₋₁	10	5	2	-	-	17	15,75	0,17	32
	KT ₁₋₂	10	5	2	-	-	34	20,00	0,17	29
	KT ₁₋₃	10	5	2	-	-	51	22,50	0,17	30
	KT ₂₋₁	10	5	4	-	-	19	18,00	0,19	23
	KT ₂₋₂	10	5	4	-	-	38	21,00	0,19	31
	KT ₂₋₃	10	5	4	-	-	57	25,00	0,19	31
	KT ₃₋₁	10	5	6	-	-	21	18,50	0,21	30
	KT ₃₋₂	10	5	6	-	-	42	23,00	0,21	30
	KT ₃₋₃	10	5	6	-	-	63	25,50	0,21	32
	KT ₄₋₁	10	5	8	-	-	23	19,50	0,23	33
	KT ₄₋₂	10	5	8	-	-	46	23,00	0,23	30
	KT ₄₋₃	10	5	8	-	-	69	29,50	0,23	28
	KT ₅₋₁	10	5	10	-	-	25	19,00	0,25	31
KT ₅₋₂	10	5	10	-	-	50	23,50	0,25	30	

Table IV Mixing proportions of the trial grouts

Tricosal H181 was added to all mixes to limit bleeding and quick setting (and thus to improve fluidity). Water contents were chosen to give a sinking time (according to German specifications) between about 30 and 32 sec, to ensure penetration of the cracks.

For each mix, specimens were prepared according to current specifications to determine bleeding and sedimentation, shrinkage, flexural strength, compressive strength, bond between bricks and grout, and modulus of elasticity. The strength tests covered periods of up to 9 months. Some results are shown below.

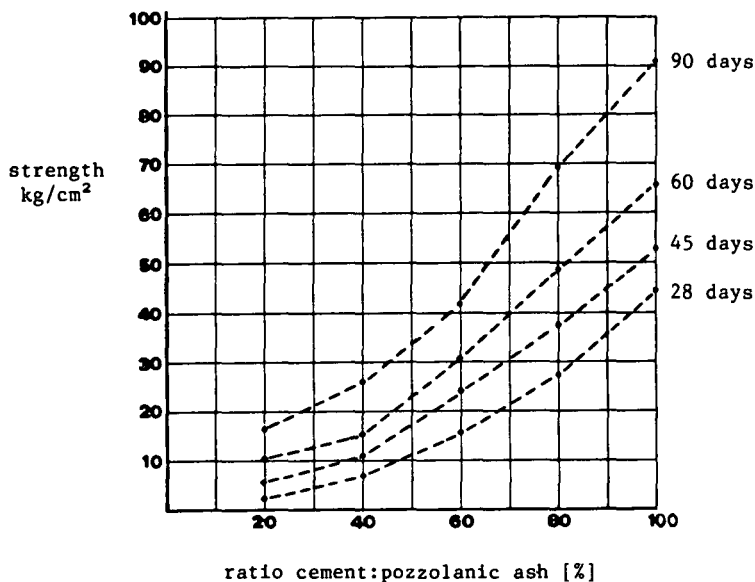

8.21 Typical variations of compressive strength of class III grouts

Tests were also made to determine whether the grout could be pumped in a hand-operated pump.

On the basis of these tests, the following grouts were selected:

- for the Roman part ET_6 for small cracks and KT_{3-1} for wide cracks.
- for the Christian part ET_6 for small cracks and KT_{4-1} for wide cracks.

8.6.3 Detailing of strengthening measures and re-analysis for the Roman part

Re-analysis to determine, in particular, the requirements for the prestressed rings was performed by the ultimate load method used in the earlier static analysis.

For the strengthened structure as finally detailed, the following safety factors and strengths were estimated:

- for gravity load only on the whole structure, a factor of 2.58, and for stress in the stitching steel in piers P2 and P3, a factor of 2.04.
- for seismic load, ultimate strengths of between 20.5 and 18.5% of gravity for the solid piers and between 21.8 and 20% of gravity for the

strengthened piers P2 and P3.

8.6.4 Proposals, detailing and re-analysis for the Christian part

A major weakness had been disclosed here in the resistance offered to horizontal thrusts exerted by the vault. The proposals, illustrated below, aimed chiefly at providing remedies for this weakness:

- the grouting of existing cracks.
- the installation of temporary transverse ties at the springing level of the vault.
- the strengthening of the existing flying buttresses (A,A below).
- the construction of an additional pair of flying buttresses (B,B below), or, as an alternative to this, the installation of permanent prestressed ties across the vault.
- the removal of the temporary ties.
- the grouting of any fresh cracks.
- the local strengthening of the apse by prestressed peripheral ties (C,C below).

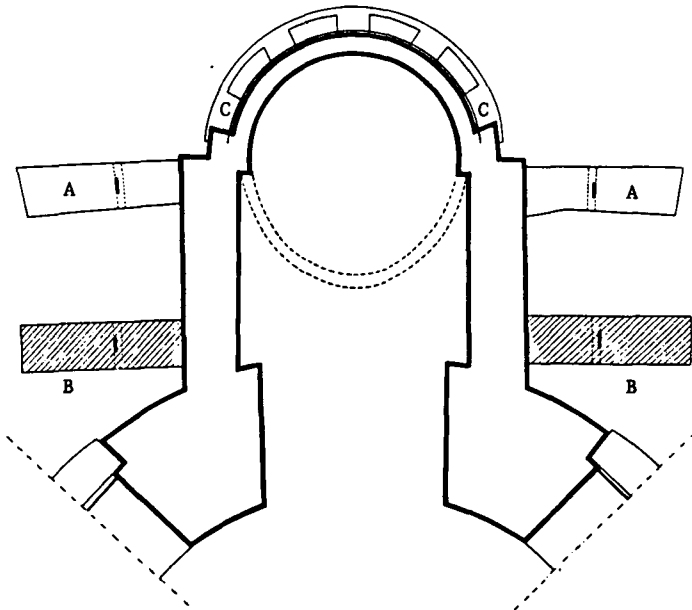

8.22 Proposals for strengthening the Christian part (1:250)

Re-analysis and detailing were again carried out following the procedures that had been adopted in the earlier analysis.

8.7 Specifications and execution

When detailed design had been completed for all the proposals, full detailed drawings and specifications were prepared including a technical description of the existing structure and details of the procedures to be followed.

The work of repair and strengthening was authorised on this basis in December 1981 and is still in progress.

8.8 Sources

8.8.1 Sources for the text

The principal source was the Greek input report, 1982, appendix to part 2:

- Penelis, G, Karaveziroglu, M, Stylianidis, K, and Leontaridis, D, 'The monument Rotunda in Thessaloniki'.

A revised version was prepared in 1983, and some further data were provided by Professor Penelis during drafting of the present account.

8.8.2 Sources for the illustrations

The illustrations are taken (with some adaptation and redrawing where necessary) from those in the Greek input report and from other drawings provided by Professor Penelis. Figure 8.4 has been completely redrawn to be more readily intelligible in relation to Figure 8.3.

9. CASE STUDY: THE CHURCH OF HAGIOS ANDREAS, PERISTERA

9.1 Introduction

The Church of Hagios Andreas is one of the smaller Byzantine monuments in and around Thessaloniki that were damaged at the same time as the Rotunda by the earthquake of June 1978. Damage was less serious, but a full investigation was undertaken as part of the general programme of research that has already been referred to in the previous study. Aspects of the research that were fully described there are mentioned only briefly here. But more detail is now given of the method of ultimate load analysis.

9.2 Description

The main body of the church was built in about 870 AD, with a central dome and four slightly smaller domes around it over the arms of a cross, as seen in Figures 9.1 and 9.2. In 1915, a narthex was added at the west, and a buttress was built against the south arm of the cross at about the same time. The interior is frescoed.

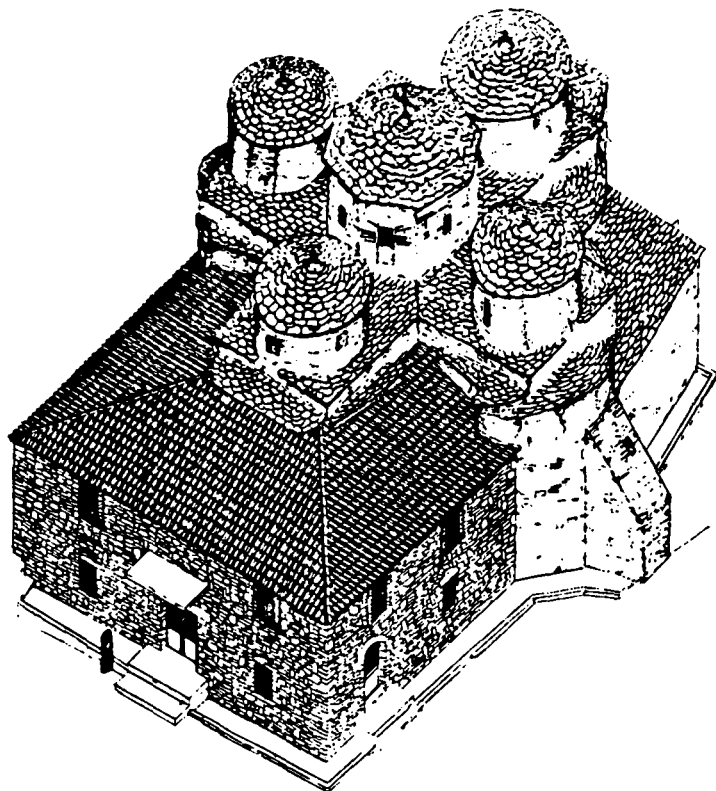

9.1 General view from the southwest

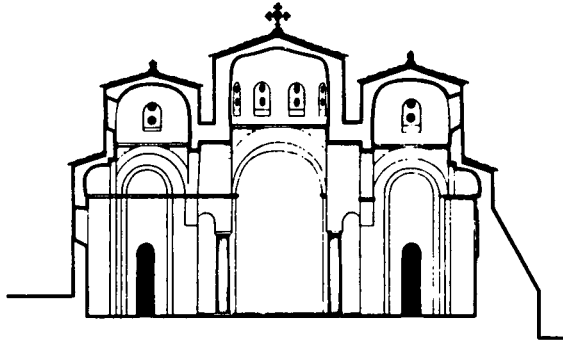
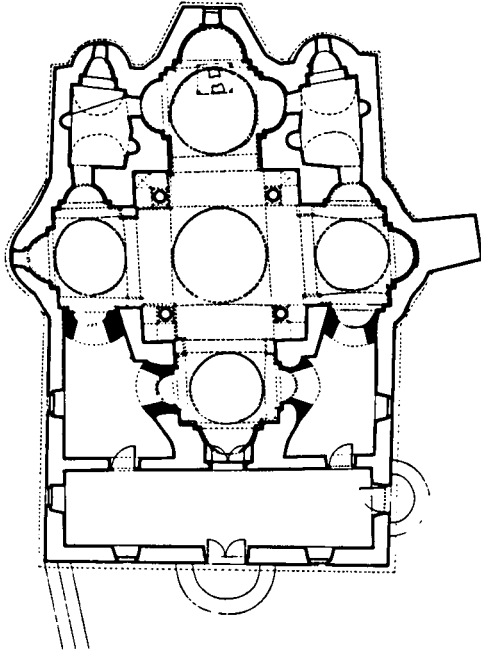

9.2 Plan and cross section looking east (1:200)

9.3 Structural condition

Before the earthquake, cracks already existed in the domes and their drums and in the supporting arches. The southern part of the church was also separated from the main body, as indicated both by the construction of the new buttress against it and by fillings of tile and mortar in old cracks.

The earthquake led to a slight worsening of these conditions. There was, for instance, a 2.6% deviation from the vertical at the SE corner. But there was no apparent danger of collapse, and no emergency shoring was considered necessary apart from the placing of some prestressed steel rings around the drums of the domes.

9.4 Detailed investigations

The investigations were similar to those undertaken for the Rotunda, though somewhat less extensive.

9.4.1 Architectural and construction survey

A precise architectural survey was made using standard survey techniques. To determine foundation conditions, several sections were cut alongside the external walls. Two sections were cut into the walls to determine the manner of construction and to obtain samples of bricks and mortar for chemical analysis. Elsewhere, the manner of construction was inferred from the character of the visible surfaces.

9.4.2 Survey of the damage

The survey of the damage included a detailed survey of the visible cracks and measurements of the inclinations from the vertical of the walls and piers.

9.4.3 Tests on materials

The taking of cores for tests on the mechanical properties was not attempted because the mortar joints were too thin for the extraction of adequate test samples. Instead, hammer and sonic tests were made over the whole external surface. (They were not practicable inside because of the risk of damage to the frescoes.) The correlation curves derived from the tests on the mortars of the Rotunda were then used to determine the strengths here. The sonic tests were used for a statistical evaluation of the dynamic modulus of elasticity to assist in the choice of suitable grouting mortars.

Chemical analyses were made to determine the same characteristics of the bricks and mortar as in the Rotunda investigation.

9.4.3 Static analyses

The domes and their drums were first analysed as linearly-elastic systems of thin shells. The central dome was modelled as a conical shell at the top, merging with a lower doubly-curved frustrum shell standing on a cylindrical drum. The other domes were modelled as semi-elliptical shells of revolution, likewise on cylindrical drums.

These analyses (taking into account the internal forces at the interfaces between shells) indicated sufficiently high tensile stresses at some sections of the drums to cause meridional cracking - especially in the central drum.

Re-analysis, with the drums modelled as rings of independent cantilevers, led to the conclusion that no tensile stresses would exist on horizontal sections at the base for gravity load only, but that stresses sufficient to cause cracking here would arise for a seismic base shear of 8%.

For the investigation of overall strength and stability, it was necessary to perform ultimate-load analyses of the combined systems of principal (dome-bearing) arches and their supporting piers. These were modelled as shown in Figure 9.4

Failure criteria for the cross sections of the piers and arches (CS I and CS II) were first plotted as interaction curves between moment (M) and direct force (N) (Figure 9.4c) and between direct stress (σ) and shear stress (τ) (Figure 9.3), derived on the following assumptions:

- the tensile strength is equal to the estimated flexural strength.
- the compressive strength is equal to the estimated overall strength of the bricks and mortar.
- behaviour in the compressive zone is similar to that of a low-strength concrete.

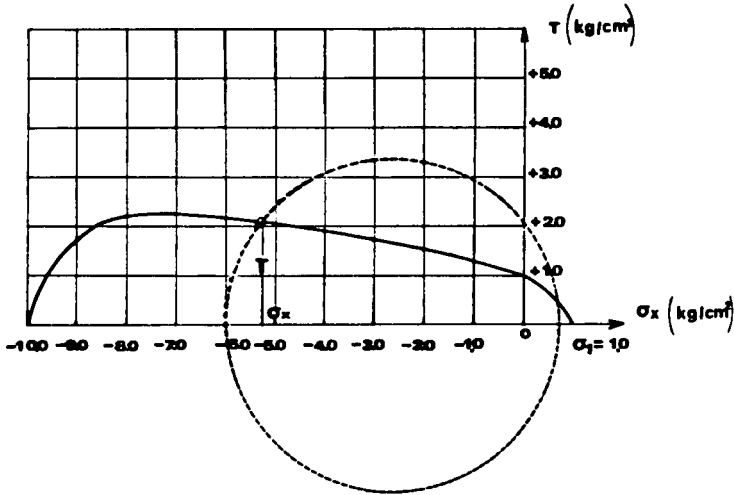

9.3 Strength of the masonry in combined shear and compression

For these analyses, a step-by-step procedure was followed - initially for service (gravity) load, and subsequently for seismic load superimposed on this. Referring to Figure 9.4c and d, a small multiple of the service load, say 0.2, is applied first. For this loading, the internal forces and moments are determined at the critical sections and plotted on the M-N interaction curves (points F_1 , D_1 , B_1 , and A_1). Extension of the line OF_1 to \bar{F}_1 on the M-N curve then gives the position of the first hinge and the corresponding load factor (i.e. point F and OF_1/OF_1). Proportionate extensions of the lines $\bar{O}D_1$, $\bar{O}B_1$, and $\bar{O}A_1$ give the corresponding forces and moments at the other critical sections. Repetition of the procedure for the new structural system with a hinge at F gives the location of the next hinges at

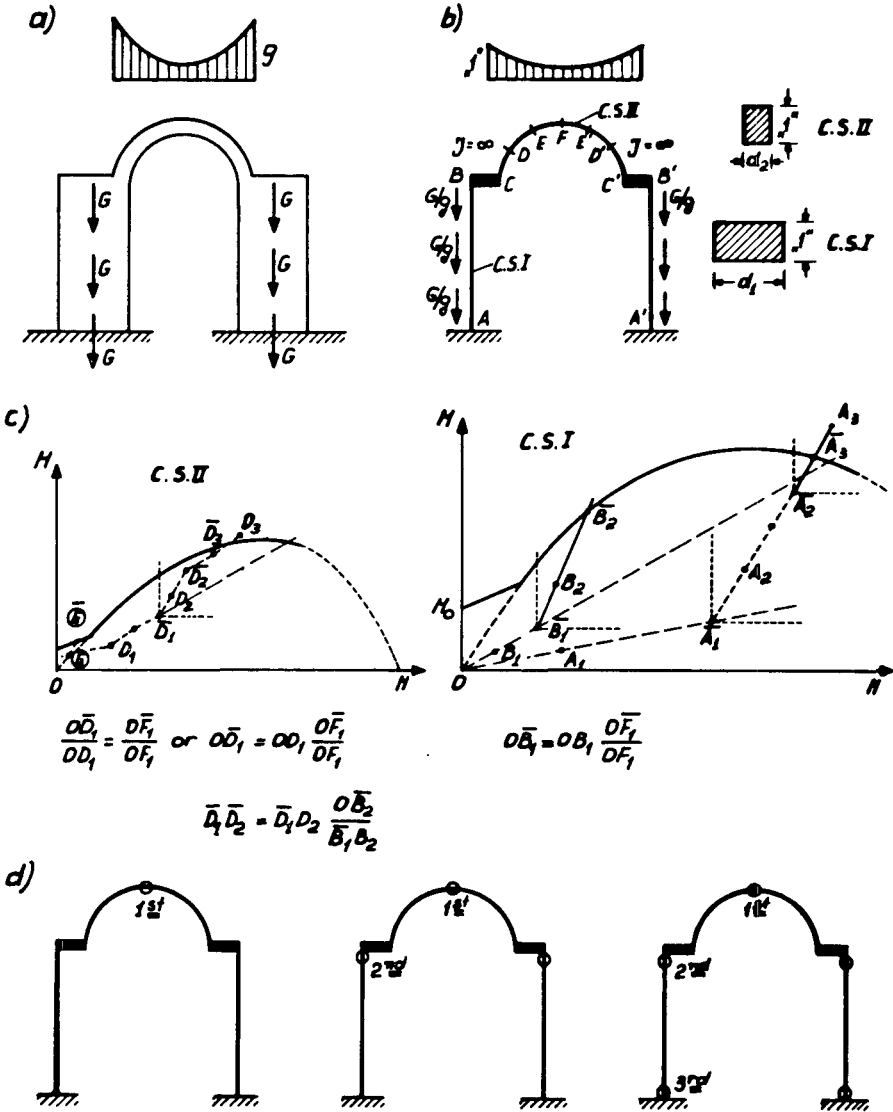

9.4 Step-by-step ultimate load-analysis of the piers and arches

B and B', the second partial load factor $\bar{B}_1\bar{B}_2/\bar{B}_1B_2$, and the corresponding forces and moments at the remaining critical sections D and A. A further repetition for the system with hinges at both F, B, and B' gives the location of the final hinges necessary to allow collapse at A and A', and the final load factor.

For response under seismic load, the same procedure is followed up to full service (gravity) load, and then continued with increasing horizontal load until a collapse mechanism forms. At each step of the analysis it is now necessary, however, to check that no shear failure will occur in the supporting system. This is done by means of the curve representing the ultimate strength of the masonry in combined shear and compression reproduced in Figure 9.3.

These analyses indicated a load factor of 1.73 for service (gravity) load, and showed that, at full unfactored gravity load, collapse would be caused by a seismic load of 12%.

9.5 Repair and strengthening

The level of safety indicated by the analyses, together with the evidence of past performance of the structure, showed that only limited intervention was desirable. The proposals were as follows:

- the grouting of cracks.
- the installation of permanent prestressed steel rings around the drums of the domes.
- retention of the buttress on the south side.

On the basis of the tests on the existing mortars and the tests on grouts described in section 8.6.2, grouts ET₂ and KT₂₋₁ (Table IV of chapter 8) were selected for filling small and wide cracks respectively.

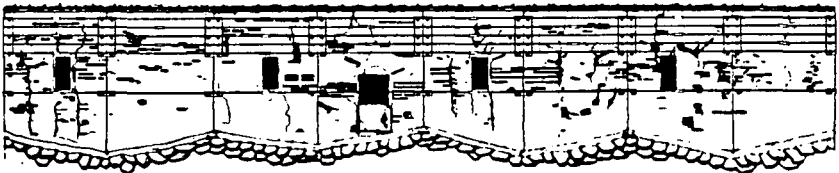

9.5 Development of the permanent prestressed tie rings of the drum of the central dome (1:100)

The prestressed tie rings could easily be removed and replaced, if necessary, at some future date. Their installation (like that of similar rings around the dome of the Rotunda) was thus a reversible intervention, for which 22/34 mild steel coated with lead was considered appropriate. The prestress was not to exceed 50 MN/m². The arrangement of the rings around the drum of the central dome is shown above.

Since no change in the overall structural system was proposed, the only further analysis that was called for was that needed to determine the cross sections and desirable prestress of these rings.

9.6 Specification

When detailed design had been completed, drawings and specifications were prepared in the same way as for the Rotunda.

9.7 Sources

9.7.1 Source for the text

The source for the text is a supplementary Greek input report, 1983:

- Penelis, G, Karaveziroglu, M, Stylianidis, K, and Leontaridis, D, 'Repair and strengthening of the Church 'Hagios Andreas' at Peristera, Thessaloniki'.

9.7.2 Source for the illustrations

The illustrations are taken (with slight adaptation) from this Greek input report.

10. CASE STUDY: THE BOYANA CHURCH, SOFIA

10.1 Introduction

The Boyana Church ranks as a major architectural and historical monument, partly on account of the fine 13th century frescoes on its interior walls and vaults, as seen below.



10.1 The frescoed interior, looking from the lower storey of the Kaloyanic church towards the apse of the earlier cross-domed church

Repair and strengthening to provide improved seismic resistance were undertaken after the church had been included in the World Heritage List in 1979 rather than as an immediate response to damage by earthquake.

10.2 Description

The name is a collective one that is given to three adjoining structures of different date within what was once a mediaeval fortress. All three are shown in Figures 10.2 and 10.3.

At the east is a small late-10th or 11th century domed cross church. To the west of this is a slightly larger two-storey church of the 13th century, with a dome again in the upper storey. This is known as the Kaloyanic church. Both these structures are constructed throughout of brick and stone masonry. Further west is a slightly broader 19th century annex with an intermediate timber floor and a timber roof.

Since the annex was considered to be of little architectural or historical interest, attention was concentrated on the earlier structures.

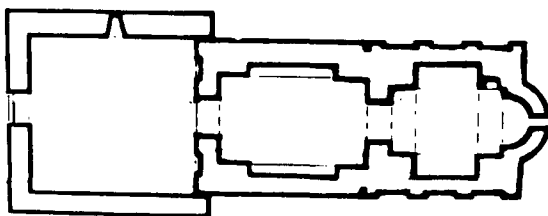
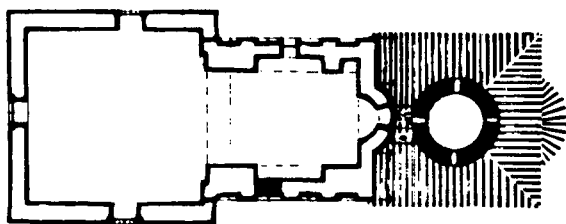
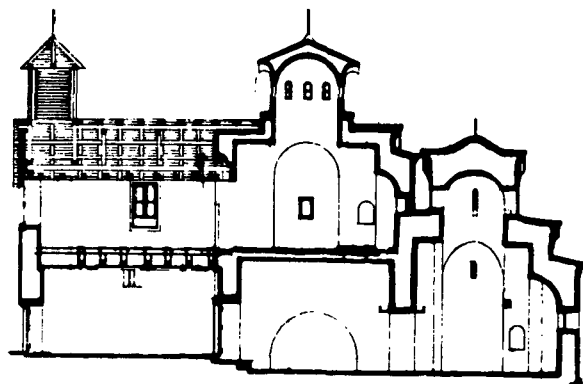

10.2 Longitudinal section and plans of the upper and lower levels (1:200)

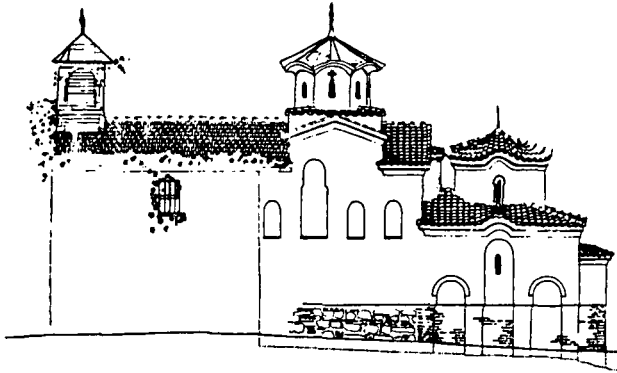

10.3 Elevation from the south (1:200)

10.3 Structural condition

The church stands on alluvial soil containing many large stones and, until 1948, had no adequate foundations. Partly for this reason, and partly because of its history of successive additions and alterations including the removal of tie bars, there were numerous cracks in the walls and vaults.

To improve the foundations, unreinforced concrete strips were poured alongside the bases of the walls in 1948, just below the floor level. There were no signs of recent movements of the cracks, but they had clearly weakened the structural interconnections.

10.4 Detailed investigations

The investigations relevant to the seismic strengthening were chiefly aimed at identifying the major weaknesses. Calculations of stresses at possible critical sections were, in this instance, made first. Tests on the materials at the likely weakest points followed.

10.4.1 Static analyses

The complexity of the overall structural form and the impossibility of establishing the precise nature of the interconnections between elements precluded an analysis of the structure as a whole. Instead, separate analyses were made for the Old (eastern) Church and the Kaloyanic Church.

All the analyses assumed linearly elastic behaviour and ignored the existing cracks. The analyses were also two-dimensional, with the cross sections modelled as linear elements or frames and with arched elements representing the vaults. The domes and drums were analysed first, then the main supporting arches and vaults, and finally the walls (together with the intermediate vault for the Kaloyanic Church).

Since the seismic hazard at the site is high, all analyses were made initially for a seismic intensity of IX. Transverse excitation only was considered for the lower part of the Kaloyanic Church, since this presented the only real danger here.

In the Old Church, the calculated stresses at the base of the drum were all safely compressive. In the walls also, considered as independent cantilevers, only low compressive stresses were found. Moderate tensions were found at the springings of the main vaults.

In the Kaloyanic Church, the calculated stresses at the base of the drum were again safely compressive, and tensions of twice the previous magnitude were found at the springings of the main vaults. A much higher tension (of about 5 MN/m^2) was found at the springings of the intermediate vault under transverse loading. But this estimate ignored the resistance offered by the east and west walls. A separate calculation, assuming that the loading was resisted by these walls, gave moderate tensions and compressions and a maximum shear of 2 MN/m^2 in the walls.

10.4.2 Tests on materials

These analyses showed that the critical regions were at the springings of the vaults and at the feet of the walls. Strengths in tension and compression were therefore determined in these regions. Since it was not possible to extract samples for test, it was necessary to adopt non-destructive methods.

The tensile strength of the masonry depends chiefly on the tensile strength of the mortar and its adhesion with brick or stone. The strength of the mortar was determined by attaching plates and rings to the mortar in selected joints, using an epoxy cement. The plates were then pulled away with a dynamometer, bringing some of the mortar with them.

The compressive strengths of bricks, stone, and mortar were all determined by means of rebound hammer tests. Readings with the hammer were calibrated against the crushing strengths of cubes of artificially carbonated mortar and cubes cut from different types of brick and stone.

10.4.3 Conclusions and supplementary analyses

When the strengths obtained in this way were compared with the calculated elastic stresses for intensity IX seismic loading, it was found that:

- the Old Church was completely safe, since the calculated stresses were everywhere less than the measured strengths.
- the upper part of the Kaloyanic Church would also be safe if the existing cracks were filled and tensile continuity re-established where it had been broken.
- in the lower part of the Kaloyanic Church, the calculated stresses were excessively high in the regions of the springings of the intermediate barrel vault, so that there would be local failures here. These failures would throw load onto the east and west walls, but would then lead to excessive stresses in these walls. Thus this church could not be considered safe.

To clarify further the safety of the Kaloyanic Church, fresh approximate calculations were made of stresses under seismic loadings of lower intensities.

These showed that the limit of strength would be likely to be reached at intensity VI. There would be cracking at intensity VII, and collapse was possible at intensity VII.

10.5 Repair and strengthening

Some strengthening of the Kaloyanic Church was clearly necessary. In undertaking it, it was desirable that the external appearance should not be changed and essential that there should be no risk of damage to the frescoes inside or any other interference with them. This called for the avoidance of all wet processes such as grouting with normal mortars and the introduction of internal elements of reinforced concrete.

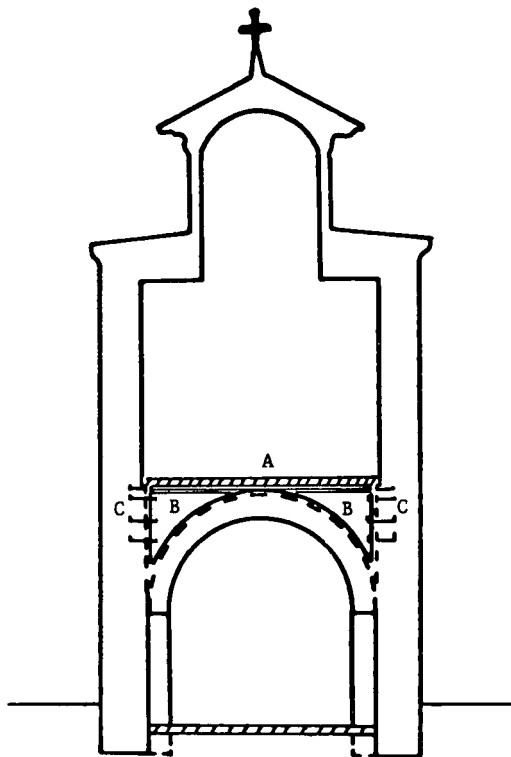

10.4 Diagrammatic transverse cross section through the Kaloyanic Church showing the new stiffening diaphragm (approximately 1:100)

The proposed scheme was as follows:

- the grouting of cracks with epoxy resin, after taking suitable measures to give full protection to the frescoes. [editorial note: the use of epoxy resins for grouting is not, however, recommended for general adoption in structures of this age and importance on account of their

unproven durability - see section 5.3.1.]

- the removal of the existing concrete floor of the upper church using a carborundum disc, followed by the removal, in stages, of the fill over the intermediate vault.
- the insertion, at the previous floor level, of the steel trussed diaphragm seen below and shown also in Figure 10.5.

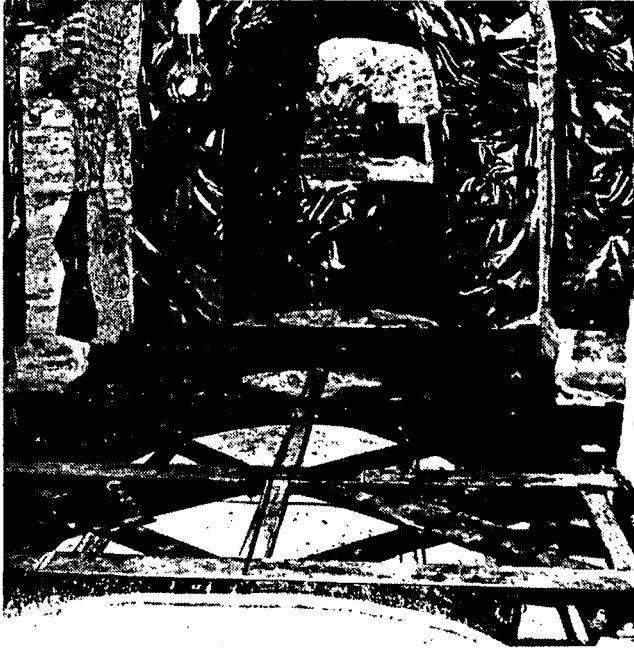

10.5 The new stiffening diaphragm installed

This diaphragm (A in Figure 10.4) has vertical ribs (B,B in Figure 10.4) which follow the curve of the extrados of the vault, and is connected to the side walls by steel anchors (C,C in Figure 10.4).

- the construction of a new floor above this diaphragm, leaving the space between it and the vault unfilled except for new air-conditioning ducts.
- the consolidation of the poor masonry of the western annex.

The new diaphragm was designed both to resist the horizontal thrusts of the intermediate vault and to transmit transverse seismic forces to the rigid east and west transverse walls.

10.6 Sources

10.6.1 Sources for the text

The principal source for the text was a Bulgarian input report, 1983:

- Venkov, V, 'Structural problems of the Boyana Church'.

This was supplemented by a copy of the static calculations supplied by Professor Venkov and by reference to:

- Kitov, V, 'The architecture of the Boyana Church', Monumentum, XXIII-XXIV, 1981, 67-74.

10.7.2 Sources for the illustrations

The illustrations are taken from photographs and drawings supplied by Professor Venkov and from the article in Monumentum referred to above.

11. CASE STUDY: THE CATHEDRAL, DUBROVNIK

11.1 Introduction

This is a considerably larger structure than those considered in the two previous studies. It was damaged in the 1979 Montenegro earthquake. Proposals for repair and strengthening were prepared in 1981-82, taking into account its importance as a historical monument and with the objective of preserving it from damage in a possible future earthquake. Works were started in 1982 and are still in progress.

11.2 Description

The present cathedral (seen below) was built in a typical Baroque style after the 1667 earthquake. It replaced a slightly smaller Romanesque cathedral with its apse just inside the present entrance portal, and this Romanesque structure itself replaced a Byzantine one. Recent excavation beneath the floor of the present nave has provided considerable new information on these earlier structures, and the evidence brought to light will be preserved beneath a new floor structure.

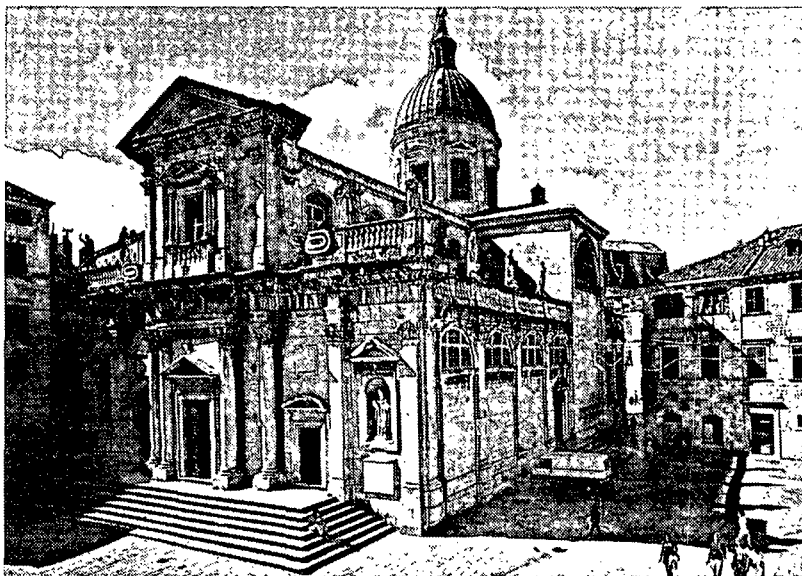

11.1 General view from the northeast

The wall and piers are built of finely dressed stone, the wall thicknesses ranging from 400 mm between the side chapels to a maximum of 850 mm, and the piers being 1000 x 1100 mm under the dome and 700 x 700 mm elsewhere. They carry masonry vaults.

11.3 Structural condition

The overall pattern of cracking of the vaults observed after the earthquake is illustrated opposite.

The chief damage occurred in the dome and at the east (main entrance) end of the nave. Radial cracking of the dome (seen also in Figure 11.3) indicated poor resistance to circumferential tensions. The cracks here were up to 50 mm wide. Cracks in the nave vaults were similar in magnitude. The most prominent of them along the crown of the easternmost vault (seen also in Figure 11.4) showed that the whole entrance facade had pulled away.

11.4 Detailed investigations

After the damage had been surveyed, investigations were made of local seismicity and foundation conditions, to permit the calculation of safety coefficients both for the existing structure as a whole and for the dome.

11.4.1 Local seismicity

It was established that a shock of intensity IX on the MCS scale might be expected with a return period of 208 years and 50% probability. This intensity corresponds to a bedrock acceleration of 0.375 g.

11.4.2 Foundation conditions

The structure was found to rest, in part, directly on bedrock, and elsewhere on the remains of the foundations of the earlier structures. Bedrock occurred at depths of 1.5 to 5.0 m below the surface. The foundation construction, where it could be seen, consisted of roughly dressed or broken stone, set in a lime or soil-and-lime mortar.

The permissible bearing stress was high enough to rule out any risk of further settlements.

11.4.3 Estimation of the strength of the masonry

No separate determination was made of the strength of the stone masonry. In the analyses, average values determined by in-situ tests on similar masonry were used. The ultimate tensile strength was taken as 0.18 MN/m².

11.4.4 Analysis of seismic resistance

Analyses were made to determine:

- overall seismic capacities at the ultimate strength of the masonry, and the corresponding safety factors.
- the safety of the dome against overturning and against horizontal slip on its base, both on the assumption that it is adequately tied circumferentially.

These analyses showed that:

- for the overall seismic coefficient of 0.30 specified by the Yugoslav Code for a masonry cultural monument exposed to shocks of intensity IX on the MCS scale, the overall safety factors were only 0.77 in the

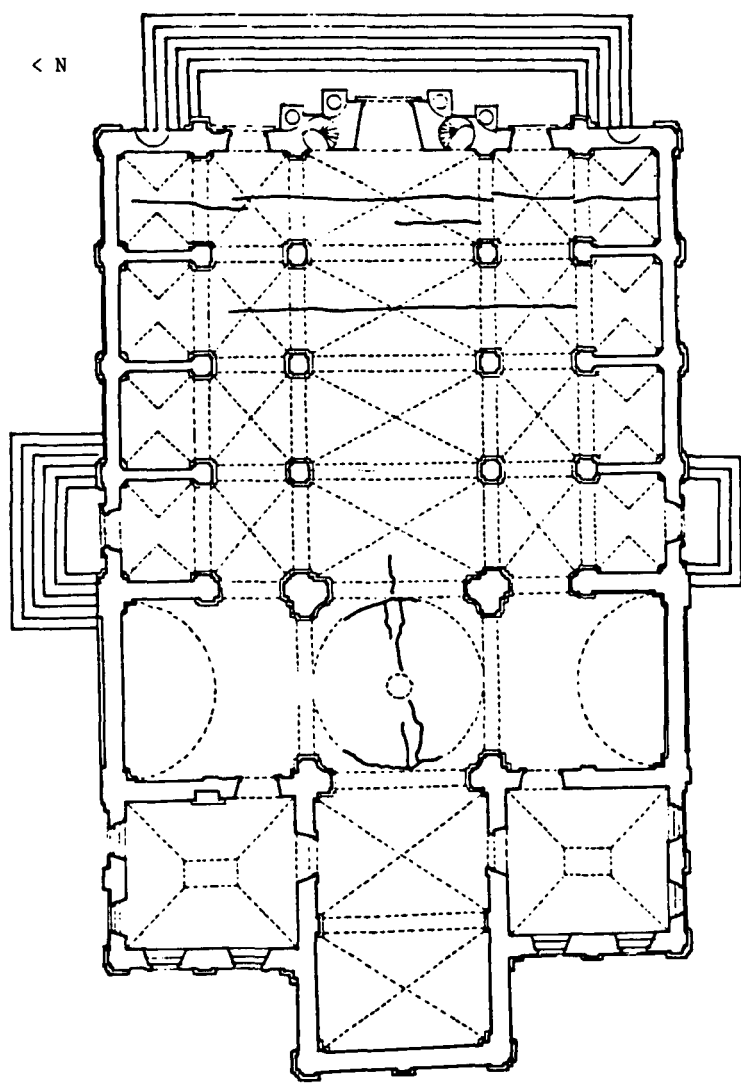

11.2 Plan showing cracking of the dome and other vaults (1:250)



11.3 Cracking of the dome

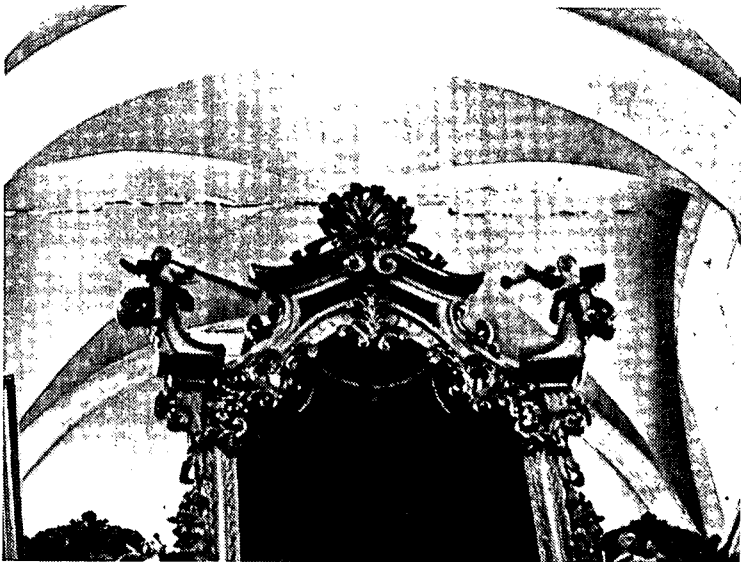

11.4 Cracking of the easternmost vault of the nave (looking east)

longitudinal direction and 0.80 in the transverse direction, even on the assumption that all vertical elements were adequately tied together so that none would fail prematurely on account of its masonry being below the average strength. At the maximum bedrock acceleration of 0.375 g, these factors were reduced to 0.61 and 0.64 respectively. Thus significant further damage was to be expected from a shock of this intensity. But all factors would be doubled for intensity VIII, and they would then be adequate.

- the dome was secure against horizontal slip, but had a safety coefficient of only 1.15 against overturning when subjected to loading of intensity IX. This suggested that some vertical anchorage was desirable.

11.5 Repair and strengthening

The scheme for repair and strengthening was designed both to make good, to the extent that seemed reasonable, the shortcomings disclosed by these analyses and repair past damage, and to restore the interconnections of the walls and piers at ground level where these had been disrupted by the excavations referred to in section 11.2. Only the works directed towards the former objective are described here.

11.5.1 Overall proposals

In the light of the past performance of the structure, it was considered more reasonable to give it an overall capacity (as indicated by the strengths of the masonry assumed in the analyses referred to above) to resist a future shock of intensity VIII with a reasonable factor of safety, and to do so without introducing any major new elements that would remain visible. This called chiefly for the installation of new ties to supplement the existing ones shown below. It was, however, necessary to give full security against overturning of the dome under loading of intensity IX as well as providing the assumed circumferential tie.

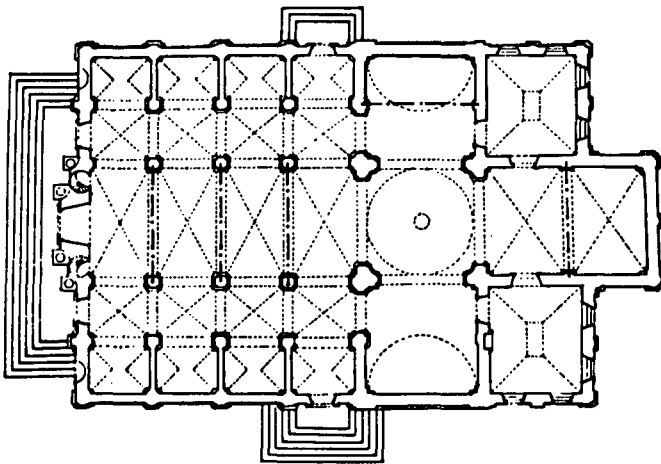

11.5 Existing high-level ties

The scheme therefore envisaged:

- the installation of additional transverse and longitudinal ties at various levels and of a reinforced concrete collar beam at the foot of the drum of the dome, all for the purpose of neutralising the horizontal thrusts of the arches and vaults and linking the walls and piers more effectively to one another.
- the repair, strengthening, and tying down of the dome.
- the strengthening of the lantern.
- the repair of cracks in the vaults.

11.5.2 New ties and collar beam

New ties will be installed at four levels as shown in Figures 11.6 to 11.10.

Individual ties consist of two lengths of round steel bar connected by a turn-buckle as seen in Figure 5.30 to permit pretensioning.

The collar beam (seen in Figures 11.6a and 11.10) is 400 mm square in cross section, and will link the four piers that carry the dome. It will be set at the level of the roofs of the nave and transepts, connecting with the highest system of ties.

11.5.3 Strengthening and tying down of the dome

The dome will be strengthened primarily by a reinforced concrete ring 300 mm square in cross section at level E in Figure 11.6a. This ring, seen in more detail in Figure 5.24b, will be provided with anchors projecting downwards into the top ring of the drum to give the necessary improvement in safety of the dome against overturning.

Further strengthening will be achieved by the application of an internal skin of reinforced gunite, 50 mm thick, as seen in Figure 5.24a. This skin will obviate the need for separate filling of the cracks.

11.5.4 Strengthening of the lantern

It is intended also to strengthen the lantern by cramping together the blocks of stone that, originally, were only mortared together.

11.5.5 Repair of cracks in the vaults

These cracks will be repaired by injecting grout, and the surfaces will then be made good.

11.6 Sources

11.6.1 Sources for the text

The principal source for the text was a Yugoslav input report, 1983:

- Zamolo, M, 'Earthquake strengthening of the Cathedral in Dubrovnik'.

This was supplemented by further information supplied by Professor Anicic.

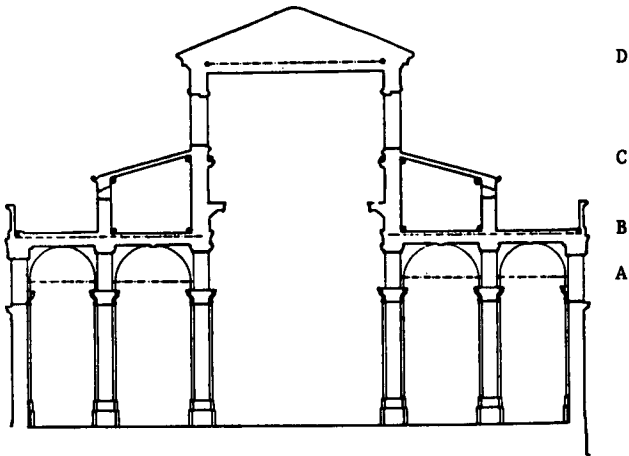
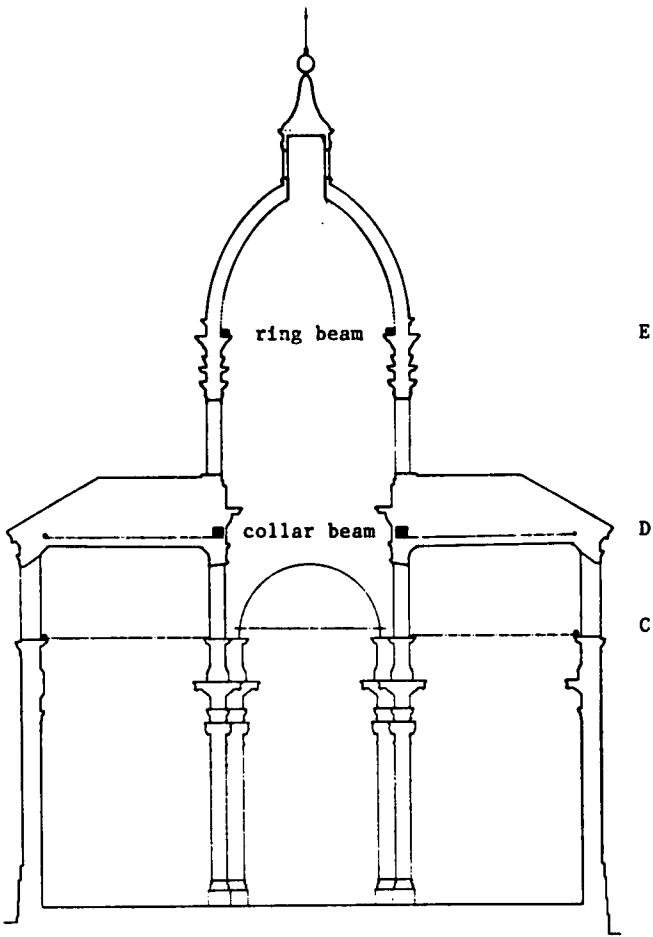

11.6 Transverse sections showing new ties and collar and ring beams (1:250)

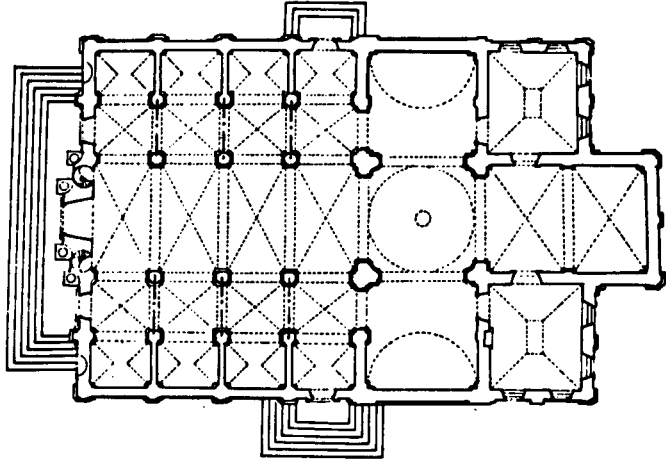

11.7 New ties at level A (1:400)

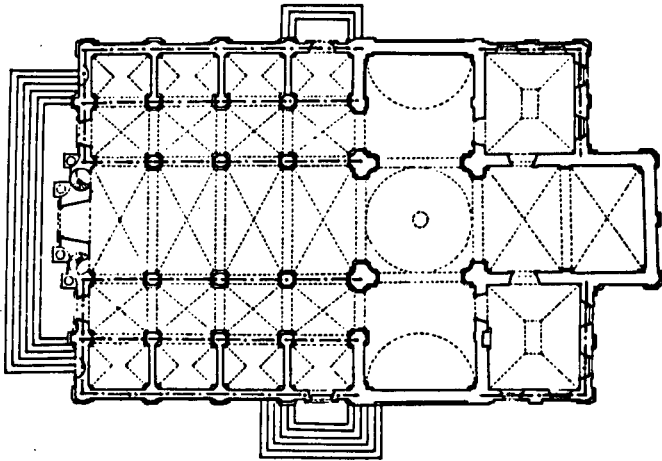

11.8 New ties at level B (1:400)

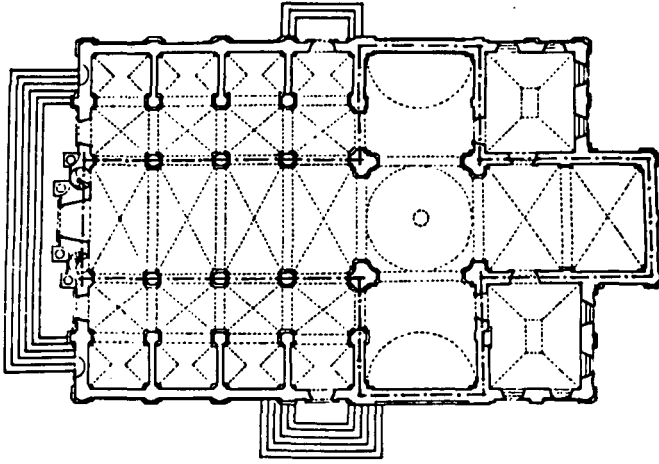

11.9 New ties at level C (1:400)

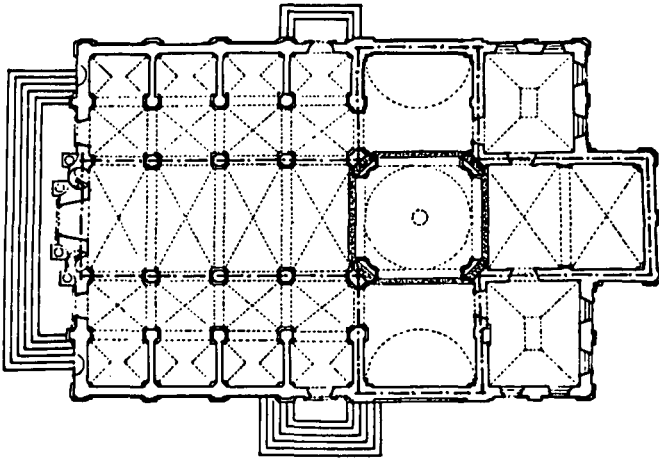

11.10 New ties and collar beam at level D (1:400)

11.6.2 Sources for the illustrations

The illustrations are taken (with some adaptation and redrawing) from photographs and drawings supplied by Professor Anicic.

Figure 11.2 is based on a drawing reproduced in IZIIS Report 81-76.

12. CASE STUDY: THE CALVINIST CHURCH, BEKES

12.1 Introduction

This structure was damaged in the Bekes earthquake of June 1978. It was built more recently than any of those described in the previous studies, and this perhaps justified the freer choice of the method of strengthening. That choice was different from the one made in Dubrovnik, although the problem faced was broadly similar.

12.2 Description

The church is a vaulted masonry structure built in the 1770s. It has a central nave and an aisle on each side over which is a gallery. The central nave rises to a height of 13 m and is 11 m wide. The main entrance is at

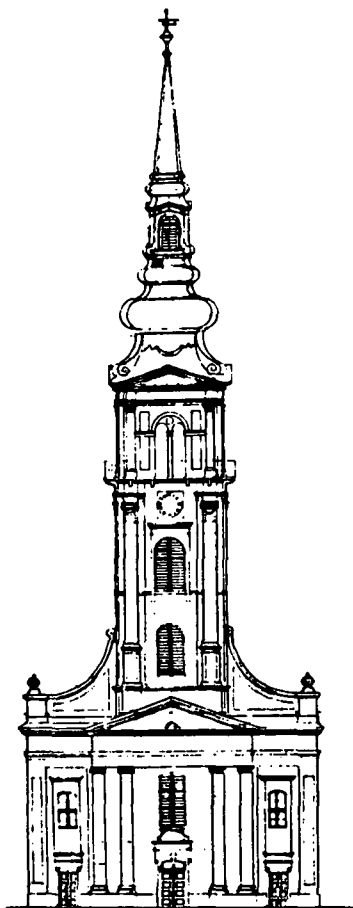

12.1 The entrance facade (1:400)

one end, the southwest. Over it rises a tower which, with its steeple, is 57 m high. In its lower part this tower, as seen in Figures 12.1 and 12.3, is much more massive in construction than the rest of the church, but there is no structural separation. The steeple is framed in timber, as is the single main roof of the church.

12.3 Structural condition

The main damage took the form of extensive cracking of the vaults, the supporting arches, and the upper parts of the side walls. This damage is summarised opposite and shown further in Figures 12.4 and 12.5. It was consistent with a predominant ground movement along the longitudinal axis of the church, as was the crack at ground level at the main entrance that is seen below. Crack widths at the upper levels were of the order of 10 mm, and diminished lower down.



12.2 Cracks in the paving of the main entrance

There was also some cracking in the tower, which must have been due partly to its tendency to respond to the ground movements at different frequencies from those of the rest of the structure.

12.4 Detailed investigations

The chief investigations were made for the purpose of predicting the seismic hazard, and related to the seismicity of the region and the local ground conditions.

After the damage had been surveyed, it was apparent that the strength of the structure and its energy absorption capacity has been considerably reduced, so that some strengthening was essential.

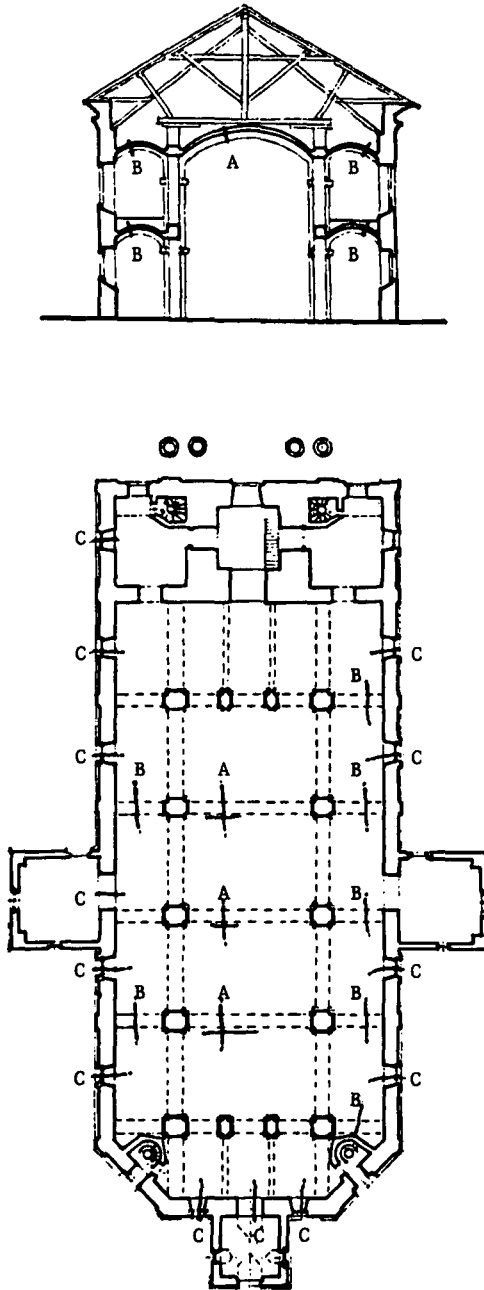

12.3 Transverse section and plan showing the principal cracks (1:400)

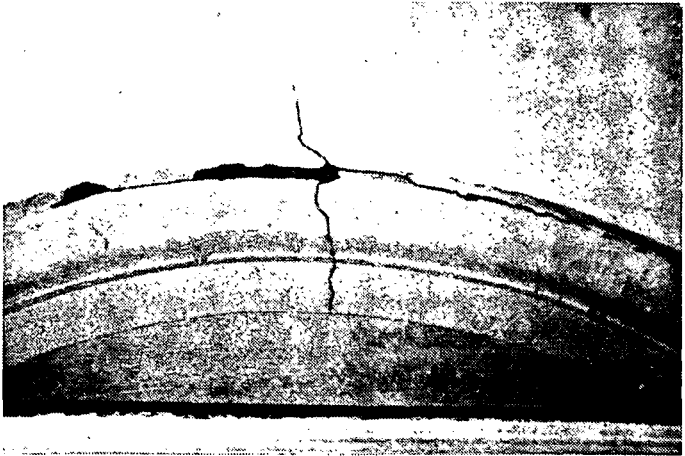
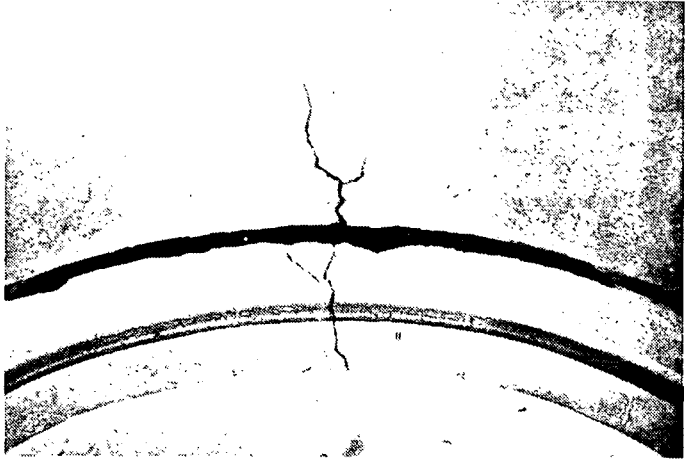

12.4 Cracking of the transverse arches and vaults of the nave



12.5 Cracking of the transverse arches and vaults of the side gallery

12.5 Repair and strengthening

The pattern of cracking indicated that the chief needs were to restore the structural continuity of the outer walls and to contain the thrusting actions of the vaults and arches. It would have been possible to do the latter by the traditional means of a system of tie bars between the springings - one of the means that was adopted in the Cathedral of Dubrovnik. But there was no evidence of the use of such ties in the church previously, and they would remain visible. It was therefore considered to be architecturally inadmissible to introduce them now. An alternative which would leave the interior looking exactly as before was sought.

The scheme adopted is illustrated in Figures 12.6 to 12.9. It comprised:

- a reinforced concrete slab, 100 mm thick, over the gallery vault at each side, marked A in Figures 12.6, 12.7 and 12.9.
- transverse reinforced concrete beams 1000 mm deep and 600 mm wide (400 mm wide at the entrance end) over the transverse arches carrying the vault of the main nave, marked B in Figures 12.6, 12.8 and 12.9, these beams being connected to the slabs just referred to over the gallery vaults.
- further reinforced concrete beams, 600 mm deep and 400 mm wide, marked C in Figure 12.9, to complete the horizontal ring system at this level.
- steel ties at approximately 1.8 m centres, marked D in Figures 12.6 and 12.9, to anchor the outer walls to this ring system.
- a second system of steel ties, marked E in Figures 12.6 and 12.7, at the

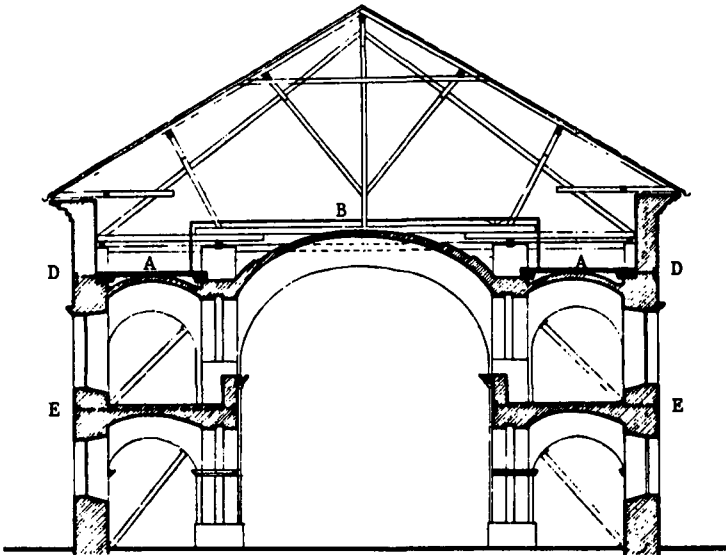

12.6 Transverse section (1:200)

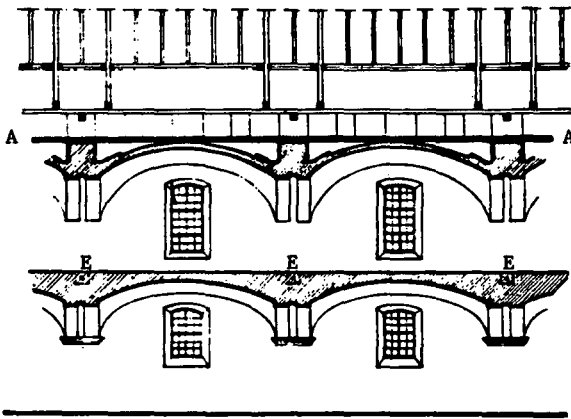

12.7 Detail of longitudinal section through side aisle and gallery (1:200)

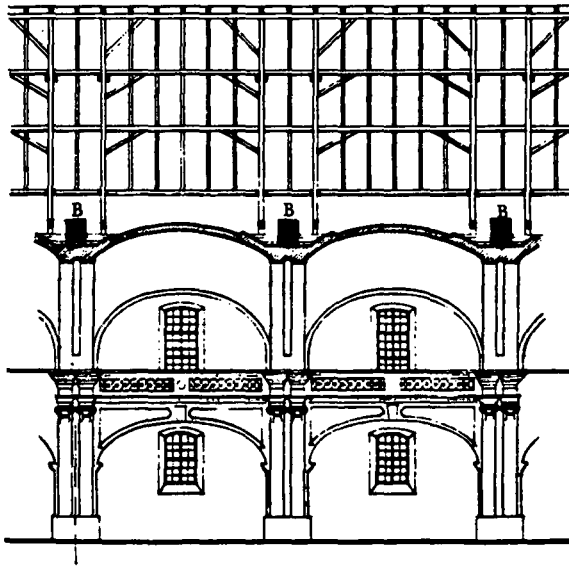

12.8 Detail of longitudinal section through the nave (1:200)

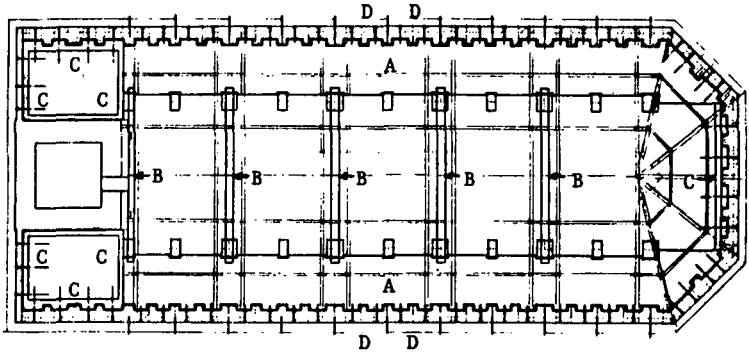

12.9 Plan at roof level (1:400)



12.10 Interior after restoration



12.11 Exterior after restoration

level of the crowns of the lower aisle vaults, anchoring the outer walls to each pier of the main nave arcade.

The detailed design of this scheme was based on purely static calculations.

12.5.1 Further strengthening of the tower

There was also considered to be a need for strengthening of the whole tower.

It was first proposed to do this by vertical prestressing by means of strands in each of the four corners. The cross sections of the masonry were sufficient to resist the additional stress, but the practical difficulties were thought to be too great.

Instead, reinforced concrete columns were introduced into the four corners, together with interconnecting ring beams and some additional cross ties.

12.5.2 High-level ring beam

The construction of another ring beam at the level of the upper cornice (roof

eaves) was considered, but was renounced on account of the likely difficulties of execution.

12.5.3 Repair of cracks

The cracks were repaired, both inside and outside, by scraping and cleaning them and then filling with mortar.

12.6 Sources

12.6.1 Source for the text

The source for the text was a Hungarian input report, 1983:

- Csak, B, Györgyfi, G, Laki, T, and Rozgonyi, M, 'The earthquake of Bekes, 22 June 1978: damages and ulterior strengthening of the Calvinist church of Bekes'.

12.6.2 Source for the illustrations

The photographs are taken from this report or were supplied by Dr Csak.

The drawings are based on the working drawings reproduced in the report.

13. CASE STUDY: THE MINARET OF EGER

13.1 Introduction

This structure was strengthened in 1970. At that time only static analyses were made. A linear dynamic analysis is now recommended in section 4.7.1 for the determination of internal forces due to seismic loading in tall slender structures of this type. As an illustration of the procedure, further dynamic analyses were made in 1983 of both the original structure and the strengthened structure, and these analyses are presented at the end of this study.

13.2 Description

The minaret, before strengthening, is illustrated below and in Figures 13.2 and 13.3. It is 37 m high, with a circular muezzin's balcony at the +25.54 m



13.1 General view early in the present century

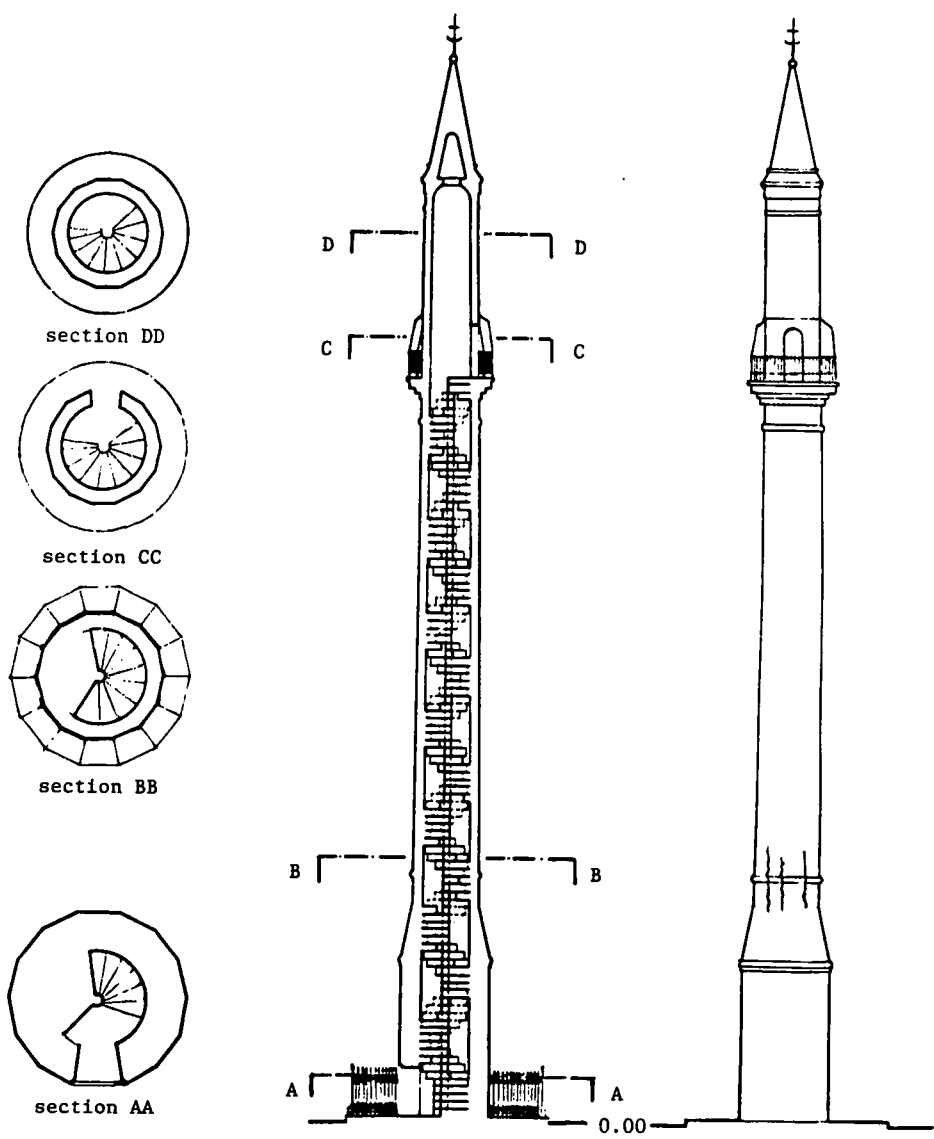

13.2 Plans, section, and elevation of the minaret before strengthening (1:200)

level. The main part of the tower and the broader base section are both twelve-sided, with diameters of 2.0 and 3.1 m respectively and wall thicknesses of 300 and 700 mm. A single helical stair ascends internally to the balcony level. The stairs are built into the outer wall with a central stone newel.

A hard sandstone was used for construction. It is finely cut, with close fitting joints.

13.3 Structural condition

The principal damage visible in 1970 was series of vertical cracks around the whole circumference of the lower part of the tower. Though hardly discernable in Figure 13.3, they are indicated in the elevation at the right of Figure 13.2.

There were also traces of frost damage penetrating up to 60 to 80 mm from the surface of the stone. Several blocks had been replaced, possibly at the beginning of the century, and others had been cut back and new facing

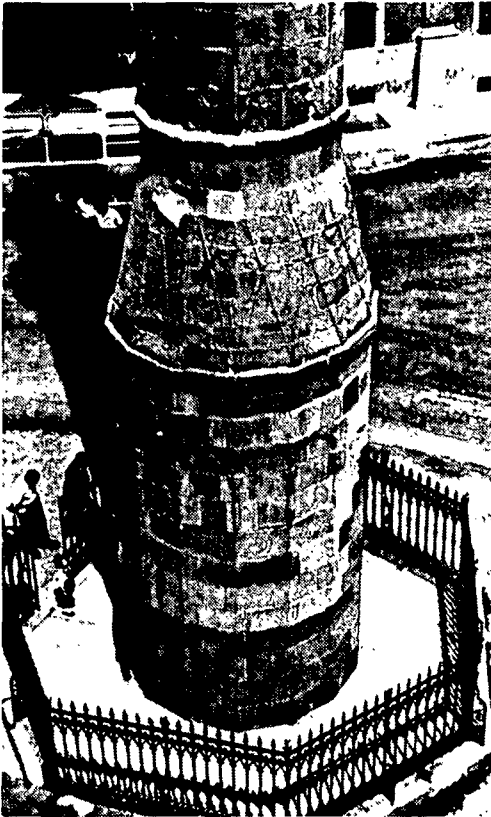

13.3 View of the base in 1970

stones mortared in place. The new stone seemed to be of better quality than the original.

13.4 Detailed investigations, 1970

Prior to analyses of stresses in the masonry, investigations were made of the foundation and soil conditions and of the precise form of the minaret. It was not possible to remove specimens of structural materials for laboratory tests, so calculations had to be based on assumed characteristics.

13.4.1 Above-ground survey

A precise survey, from which Figure 13.2 is taken, indicated no deviation from the vertical.

13.4.2 Foundation and soil conditions

No records were available from the time of construction. Trial boreholes were therefore made to discover the nature of the foundation and the soil. Within a circle of 12 m radius, four 55 mm diameter holes were bored to a depth of 5.4 m, and one pit was dug to a depth of 3.6 m.

These disclosed 1.6 to 1.8 m of clayey fill near the surface, followed by 1.0 to 1.2 m of rich black clay, up to 3.1 m of rich grey clay, and, at the bottom, a grey muddy pebbly clay. The load-bearing capacity of the soil at foundation level was estimated by laboratory and other tests as 0.35 MN/m^2 , although none of the trial holes reached this level.

The form of the foundation that was assumed for purposes of calculation is shown below.

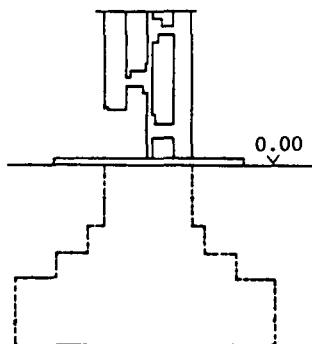

13.4 Assumed cross section of the foundation (1:200)

13.4.3 Structural analysis and assessment

Static analyses of internal forces and moments were made for both wind and earthquake loading. Since there was no valid seismic code in Hungary in 1970, the earthquake loads were taken from the Yugoslav code for an intensity in the range MSK VII to VIII.

The full calculations are no longer available, so that it is possible to present only the principal conclusions.

The critical cross section is at the foot of the main cylindrical part of the tower, just above the conical transition from the broader base, and it is approximately annular.

For the assumed ultimate crushing strengths of the stone and mortar of 10.0 and 1.0 MN/m² respectively, the Hungarian standard gave an allowable ultimate strength of the masonry of 1.6 MN/m². Assuming no tension, it was found that this stress was exceeded at the critical section even when only self-weight and static wind load were considered. It was exceeded to a greater extent under dynamic wind load or earthquake load.

Nevertheless, the structure had stood for several centuries with only minor evidence of possible weaknesses.

Possible reasons for this were:

- some tensile resistance by the masonry.
- a higher ultimate compressive strength of the masonry than the allowable value estimated from the assumed strengths of the stone and mortar.
- overestimation of the loadings in relation to those hitherto experienced.

Strengthening was, however, decided upon, on account of the observed cracking and the adverse indications of the calculations in relation to the normal safety requirements.

13.5 Strengthening, 1970

While the primary objective was to ensure the future safety of the monument in accordance with the indications of current standards, it was considered essential that this should be done without without any change in the external appearance.

13.5.1 Alternative schemes considered

The following alternatives were considered:

- prestressing by vertical tendons.
- the addition of an internal reinforced concrete skin.

The first seemed a simple and elegant solution which would leave no visible traces. It was, however, considered impracticable because the masonry cross section was already too heavily loaded to support the additional compression from the necessary prestressing force of about 1000 kN.

The second solution was therefore adopted.

13.5.2 Construction of an internal reinforced concrete skin

A skin, 60 mm thick, was constructed over the whole internal surface of the tower wall, as shown in Figure 13.5.

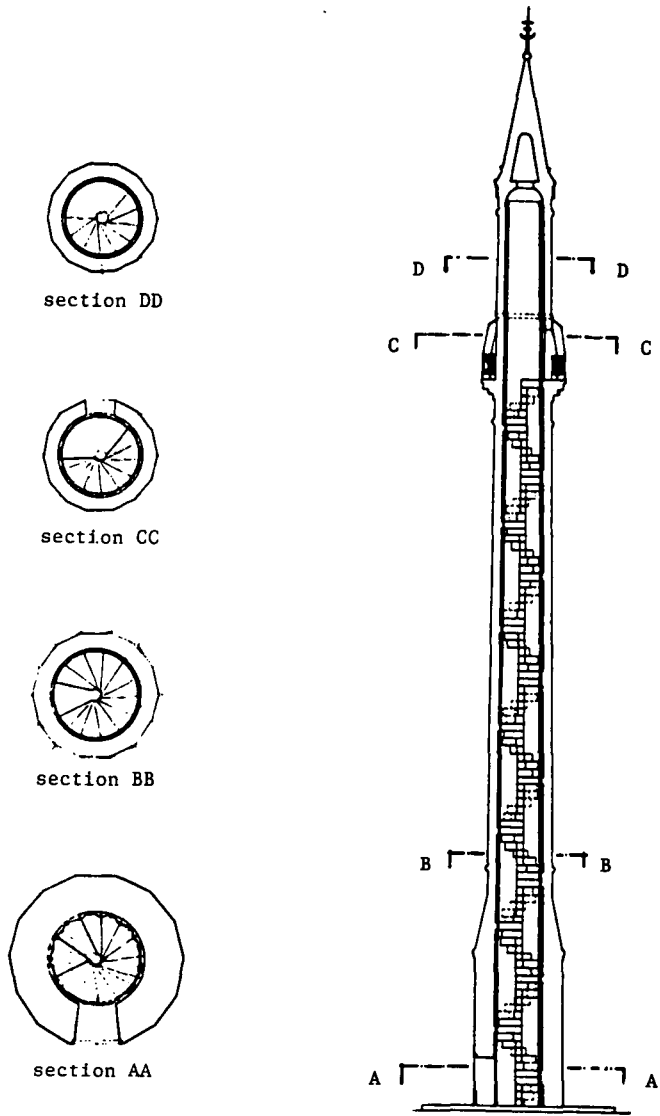

13.5 Plans and vertical section of the minaret after strengthening (1:200)

Grade C28 concrete was used, and was pumped in place. It was reinforced with 20 mm and 22 mm vertical steel bars and 8 mm helical bars following the ascending stair. The vertical reinforcement was made continuous by thread-bars through 30 mm holes drilled in the stairs close to the wall, and by ensuring adequate laps of successive lengths of bar.

To ensure the full interaction of the existing masonry and the new internal skin, the mortar joints were raked out and the stones washed before concreting. Penetration of the raked-out joints by the concrete thus provided continuous shear keys to supplement the natural bond between concrete and stone.

13.6 Subsequent dynamic analysis, 1983

In 1983, the internal forces and moments were recalculated dynamically using computer facilities that had not been available in 1970. These calculations were made according to the Hungarian Seismic Code of 1976 for intensity MSK VII, and for both the unstrengthened and strengthened states of the monument.

13.6.1 Structural modelling and calculation of natural frequencies and mode shapes

The mass of the structure was assumed to be concentrated at 38 points, as shown in Figure 13.6, and the stiffness of the foundation was represented by horizontal, vertical, and rocking springs at ground (0.00) level. The elastic modulus of the masonry was taken as 16000 MN/m², and damping was neglected. Necessary integrals were calculated by Simpson's rule.

The circular frequencies and deflections of the first three natural modes of vibration were then calculated by the iterative application of the Rayleigh energy method. Modal displacements are shown in Figure 13.6 and calculated circular frequencies were as follows:

		fundamental	1st harmonic	2nd harmonic
circular frequency (sec ⁻¹)	unstrengthened	6.47	26.49	48.43
	strengthened	6.36	33.20	53.00

13.6.2 Calculation of internal forces and moments

From these frequencies and modal displacements, the seismic shear forces at each section and the corresponding bending moments were calculated for each mode in accordance with the code. Those for the unstrengthened state are plotted in Figures 13.7 and 13.8.

Finally combined moments were calculated from the formula given in clause 4.3.8 of the code:

$$M_{\text{comb}} = \sqrt{M_{\text{max}}^2 + 0.5 \sum M_i^2}$$

where: M_{comb} = combined moment
 M_{max} = maximum moment
 M_i = moments for other modes

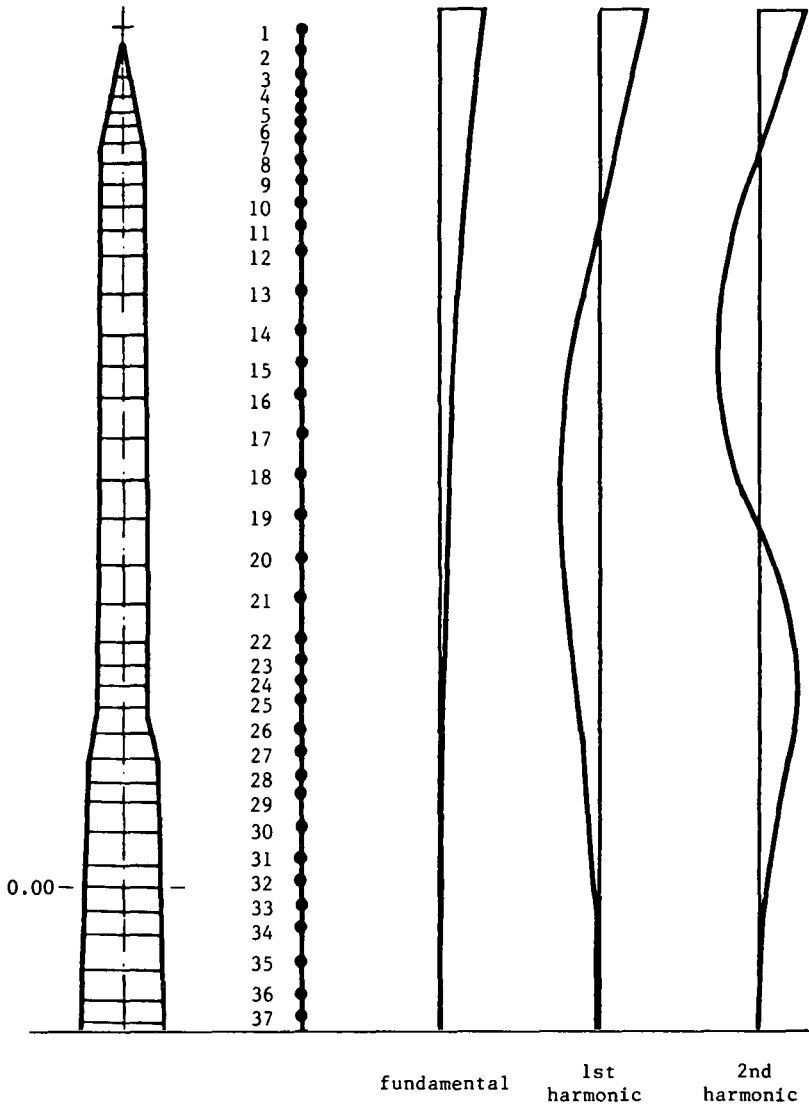

13.6 Structural model and first three mode shapes

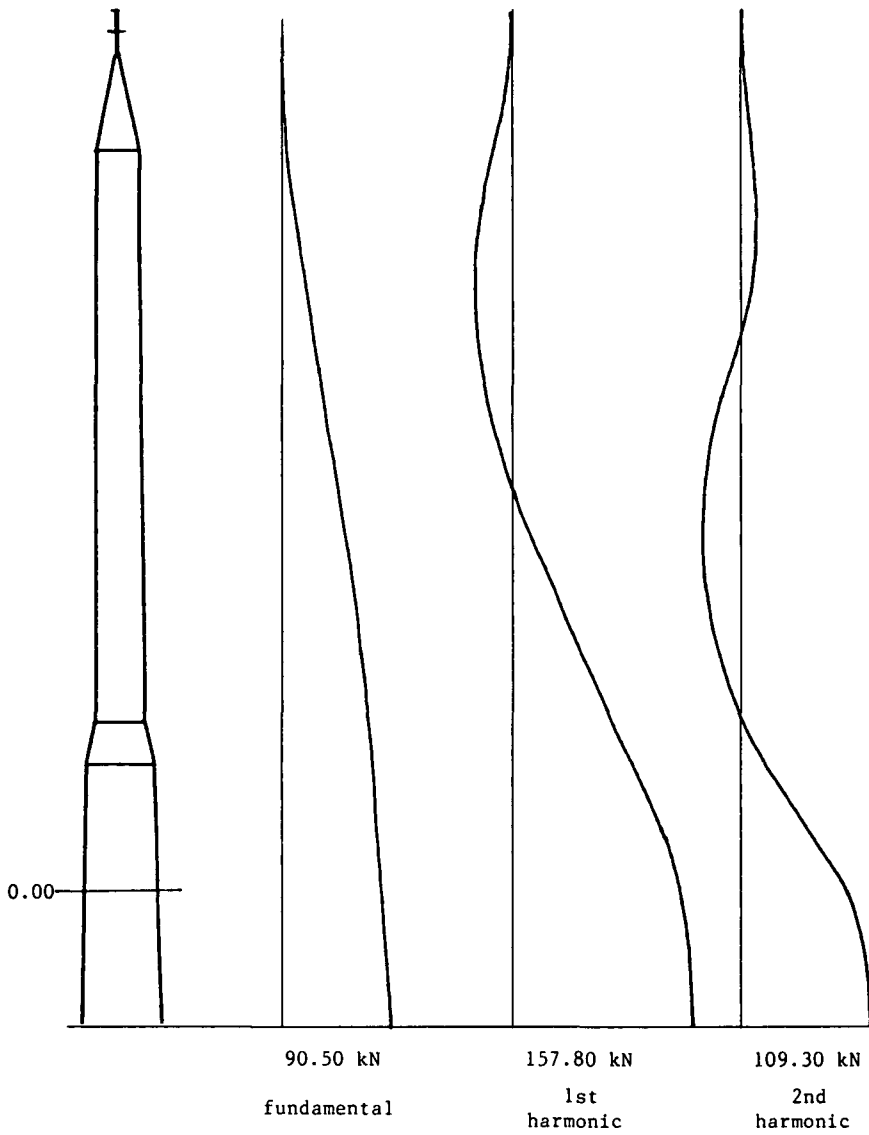

13.7 Modal seismic shear forces in the unstrengthened state
(1 cm = 50 kN)

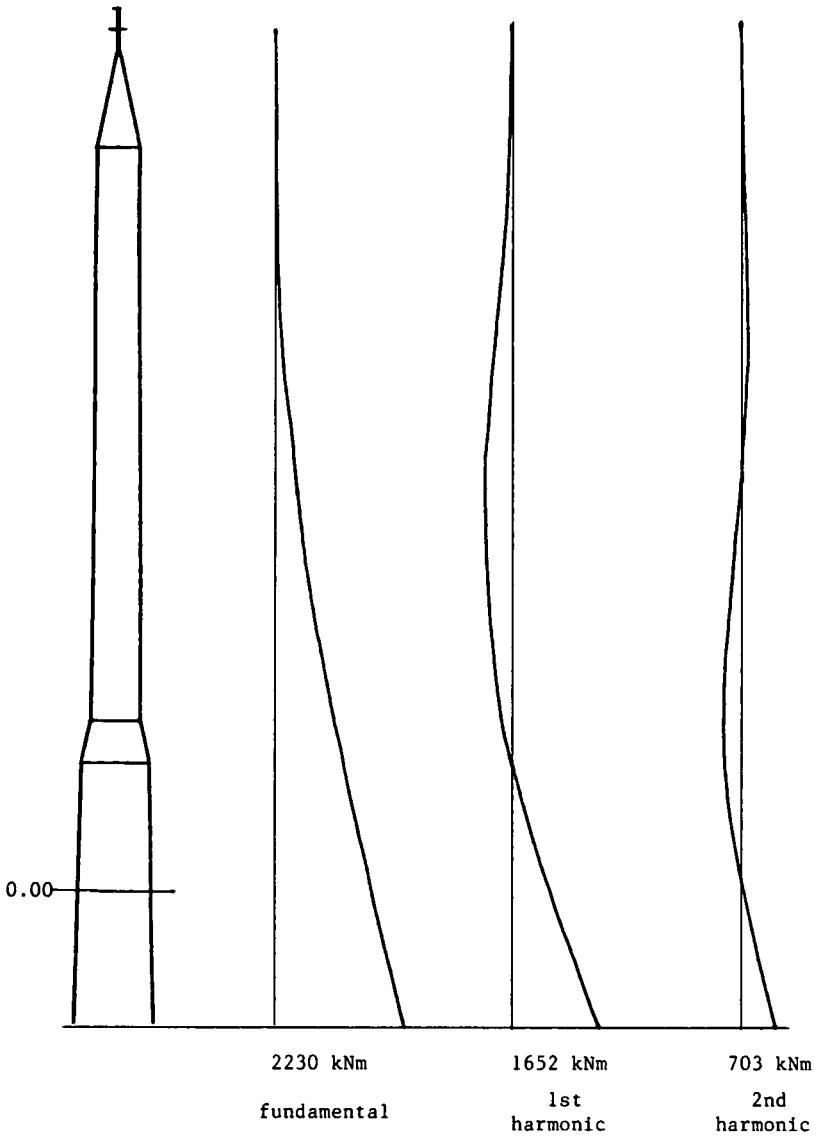

13.8 Modal seismic moments in the unstrengthened state
(1 cm = 1000 kNm)

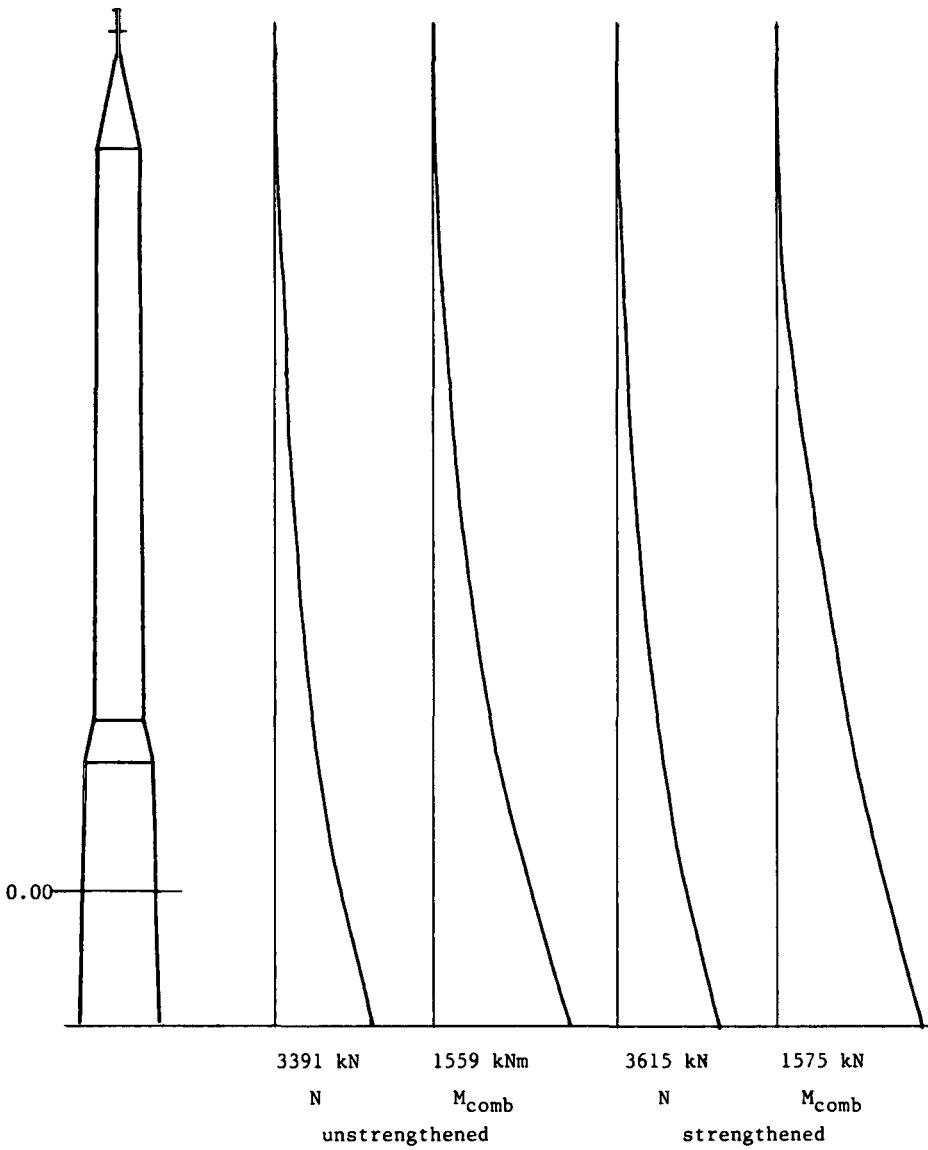

13.9 Normal forces and combined seismic moments in both states
(1 cm = 2000 kN or 1000 kNm)

Combined moments for both unstrengthened and strengthened states are plotted in Figure 13.9, together with the corresponding normal forces.

It will be seen that strengthening results in some increase in the moments that would be experienced, the proportionate increase being greatest in the main cylindrical portion.

13.6.3 Checks on safety

On the basis of these recalculated moments, fresh checks were made on the safety of the monument in both states. These checks were made for both elastic and plastic behaviour of the cross sections, although the combining of the individual modal responses was strictly valid only for linear elastic behaviour.

For the assumed intensity of MSK VII, the unstrengthened structure was again found to have been unsafe, whereas the strengthened structure was safe. As shown below, the moments in the critical sections in the lower part of the main cylindrical portion are well within the ultimate bearing capacity after strengthening.

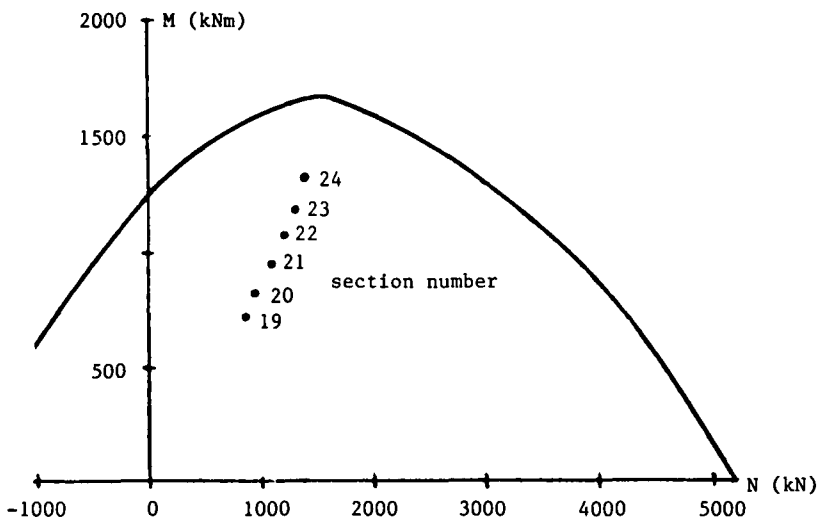

13.10 Ultimate bearing capacity and safety of the cylindrical portion after strengthening

13.7 Sources

13.7.1 Sources for the text

The principal source for the text was a Hungarian input report, 1983:

- Csak, B, Györgyfi, G, Laki, T, and Rozgonyi, M, 'Strengthening of the Minaret of Eger'.

This was supplemented by details of further calculations and other information supplied by Dr Csak.

13.7.2 Sources for the illustrations

The photographs are taken from the input report.

Figures 13.2, 13.4, 13.5 and 13.10 are adapted from drawings reproduced in the input report or supplied by Dr Csak.

Figures 13.6 to 13.9 are based on the calculations and drawings supplied by Dr Csak.

14. CASE STUDY: FREE-STANDING DEFENCE WALLS

14.1 Introduction

It has not proved possible to include a representative detailed study of the repair and strengthening of a system of defence walls, similar to the studies presented hitherto. According this study takes a different form, and draws on a number of examples to amplify and illustrate further the relevant comments in chapters 3 and 5.

14.2 Description

Surviving defence walls vary widely in date and manner of construction.

On the one hand there are partial survivals from Mycenaean (Figures 3.7 and 3.30) and Classical (Figures 3.8, 3.14, and 3.15) times, well built throughout of large blocks of stone and without subsequent additions or modifications. A few later examples, like the Ottoman castle of Rumeli Hisari, have also retained their original form.

More typically, where the walls are, in origin, of fairly early date and have repeatedly changed hands, they have been repeatedly repaired and added to or modified. A good example of this is the castle of Acrocorinth, seen in Figure 14.1. Here, the earliest construction is of the Classical period. But these walls were added to by the Byzantines in the 6th and 13th centuries, by the Franks in the 13th and 15th centuries, and then by both Venetians and Turks. In such cases, construction is likely to be very variable, as are the foundation conditions.

14.3 Structural condition

Structural condition also varies greatly. Deterioration is possible from a number of causes: man-made damage, natural erosion of the wall masonry, erosion of the ground or other change in ground conditions, vegetation, ill-judged repairs or modifications, and earthquake. These are considered briefly below.

14.3.1 Man-made damage

Man-made damage includes the robbing for building materials to which all structures that have ceased to serve a clear practical purpose are liable. But it also includes the damage done in warfare if this was not soon made good by an effective repair. The hole made by a cannon ball can, if left open, result in progressive accelerated erosion as seen in Figure 14.2. Deliberate undermining can have results similar to those of natural erosion of the ground.

14.3.2 Natural erosion of the wall masonry

Natural erosion is usually most damaging where the rubble interior of a wall is exposed by, for instance, a cannon shot, or where there is considerable moisture movement. The latter is likely at ground level in the absence of good drainage, and it may also occur at higher levels if water collects there, perhaps behind a parapet or behind the springing of a vault. Serious erosion can threaten stability.

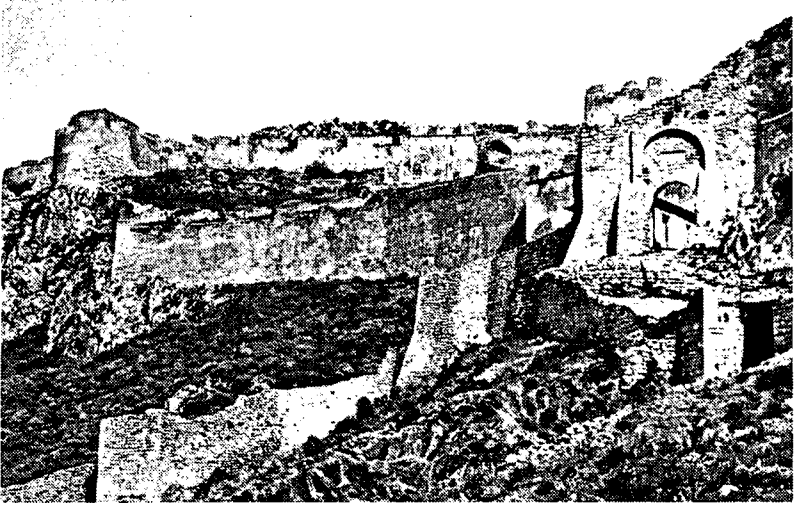

14.1 Castle of Acrocorinth



14.2 Damage initiated by gunfire, Castle of Acrocorinth

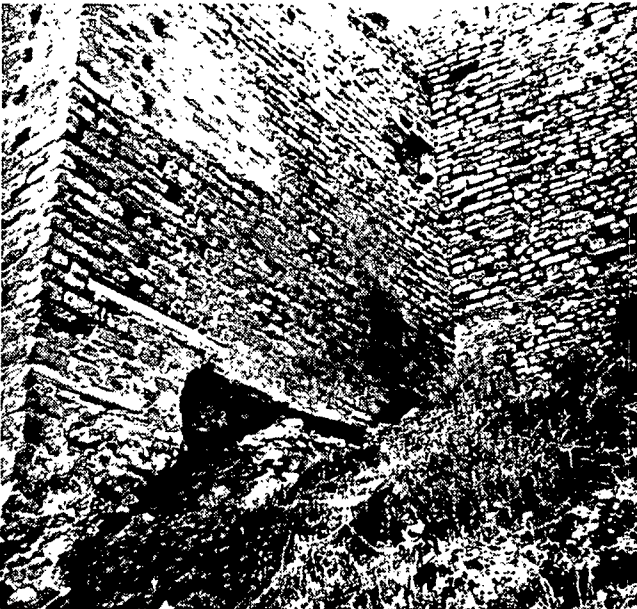

14.3 Partial erosion of foundation, Castle of Acrocorinth

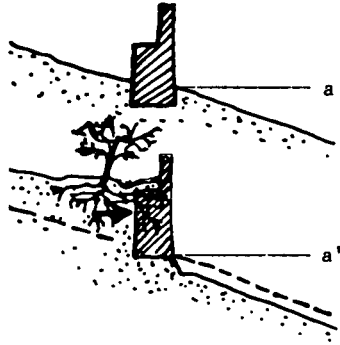

a Original and subsequent states

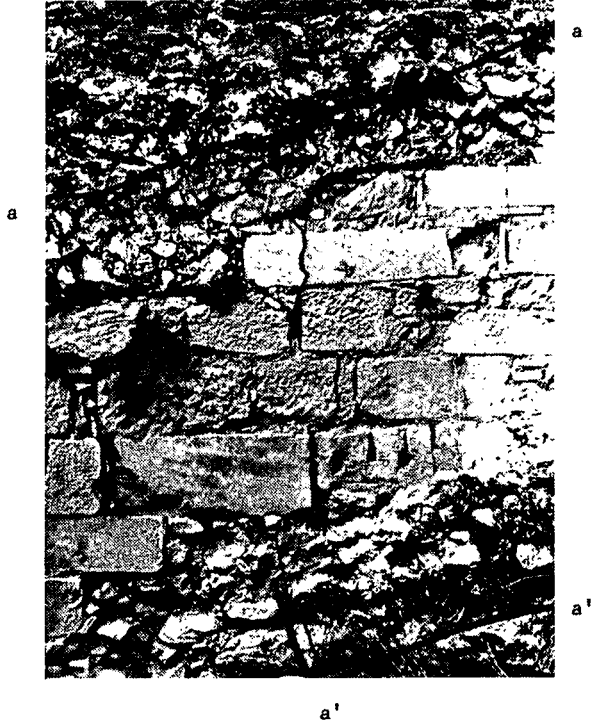

b Foundation laid bare on the outer face

14.4 Castle of Levadhia

14.3.3 Erosion of the ground and other changes in ground conditions

Soil erosion can reduce or partly remove the support at the base of a wall. In the case illustrated in Figure 14.3, some of the support has been removed in this way and the wall above has been left bridging over the gap between rock outcrops on which the adjacent sections of wall stand. In Figure 14.4, a potentially dangerous situation is shown in which erosion alongside the outer face of the wall has laid bare the foundation courses on this side (Figure 14.4b), while the ground level on the inside has risen considerably and created earth pressures tending to overturn the wall.

Other damage has been caused by differential settlements. Figure 14.5 shows numerous vertical cracks caused by differential settlement of the soft sedimentary underlying soil.

Often walls were built on sloping ground to take full advantage of a site which offered good natural defence. This introduces the further risk of major slips. An extreme example was illustrated in Figure 3.29.

14.3.4 Damage caused by vegetation

Because defence walls stand in the open, they are more prone than other structures to damage by the roots of growing vegetation, particularly in situations like that shown in Figure 14.4a, and in situations where poor drainage leads to dampness and local erosion of the facings.

14.3.5 Damage caused by ill-judged repairs or modifications

Repairs and modifications have sometimes led to damage where they have overloaded the existing wall by increasing its height or attempting to restore its earlier height, or where they have introduced elements or areas of an incompatible stiffness or permeability. Examples were shown in Figures 5.10 and 5.11.

14.3.6 Damage by earthquakes

Since defence walls are, in general, well fitted by their form to withstand ground shaking, the damage that has occurred has usually been at points of pre-existing weakness due to damage of one or other of the kinds discussed above.

Instances may be seen in Figures 14.6 and 14.7. There was almost certainly pre-existing vertical cracking of the tower in Budva, while the damage in the castle of Skyros was largely due to movement of the subsoil. It is also probable that the collapsed overhanging section of the tower seen in Figure 3.87 was of later date than the wall below.

Where damage has occurred to the unaltered original construction, it is most likely to be found at marked changes in direction or stiffness.

14.4 Detailed investigation

No investigation comparable in depth to those described in previous studies is known to have been made hitherto, although investigation is now in hand for some Greek castles. One obvious requirement is a good structural survey. In the light of the above discussion of structural condition, it is also important to explore the foundation conditions, the sequence of con-

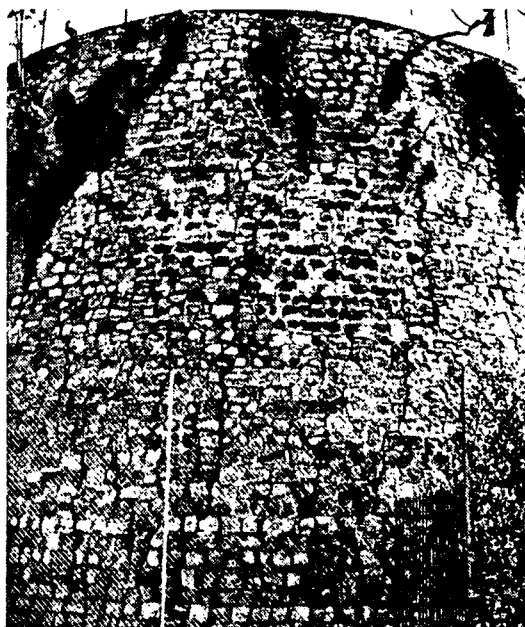

14.5 Castle of Heraklion



14.6 Tower in the Budva defence wall



14.7 Castle of Skyros

struction, and the causes of all significant damage. To assist in the choice of materials for repair, the existing materials should be identified.

14.5 Repair and strengthening

It would seem wise, in general, to limit repair and strengthening to the repair of local damage in a manner as close as possible to the existing construction, coupled with the elimination, as far as possible, of causes of damage such as bad drainage, growing vegetation, and adverse changes in the foundation conditions. Rebuilding that will significantly add to the loads on the existing wall should be undertaken only after very careful consideration. (A Bulgarian suggestion is to undertake works of this kind by first constructing a relatively light internal frame of reinforced concrete and then adding a facing to resemble the original construction, but this procedure is open to criticism in the light of the principles discussed in chapter 2, and will not always be appropriate.)

As with other types of structure, the best safeguard against future damage is possibly good maintenance, for which some permanent arrangement is, in this case, particularly desirable. Such an arrangement does already exist in some places. Figures 14.8 to 14.10 illustrate recent repairs of the walls of Thessaloniki after the 1978 earthquake by the group responsible for their conservation.

14.6 Sources

14.6.1 Sources for the text

The text has drawn, in part, on the following Bulgarian and Greek input reports, 1983:

- Venkov, V, 'Techniques for conservation and restoration of fortress wall'.
- Delincola, E, 'A brief note on the existing situation and problems of castles in Greece'.
- 'Medieval castles of Dodecanese: seismic behaviour and relevant problems'.
- Chrysafi, M, 'Acrocorinthos Castle'.

14.6.2 Sources for the illustrations

The illustrations are taken from prints supplied by Miss Miltiadou of illustrations in the Greek input reports except for:

- Figure 14.6: consultant.
- Figures 14.8 to 14.10: 9th Superintendency of Byzantine Monuments, Thessaloniki (Mrs Nicolaidou).



14.8 Tower 15 before and after repair, Thessaloniki

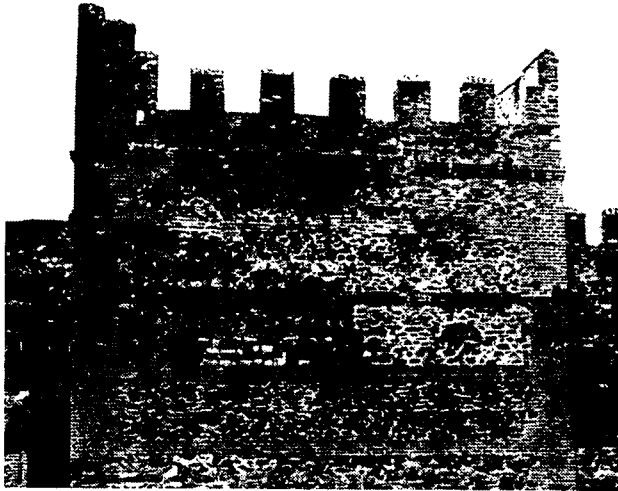

14.9 Tower 27 before and after repair, Thessaloniki

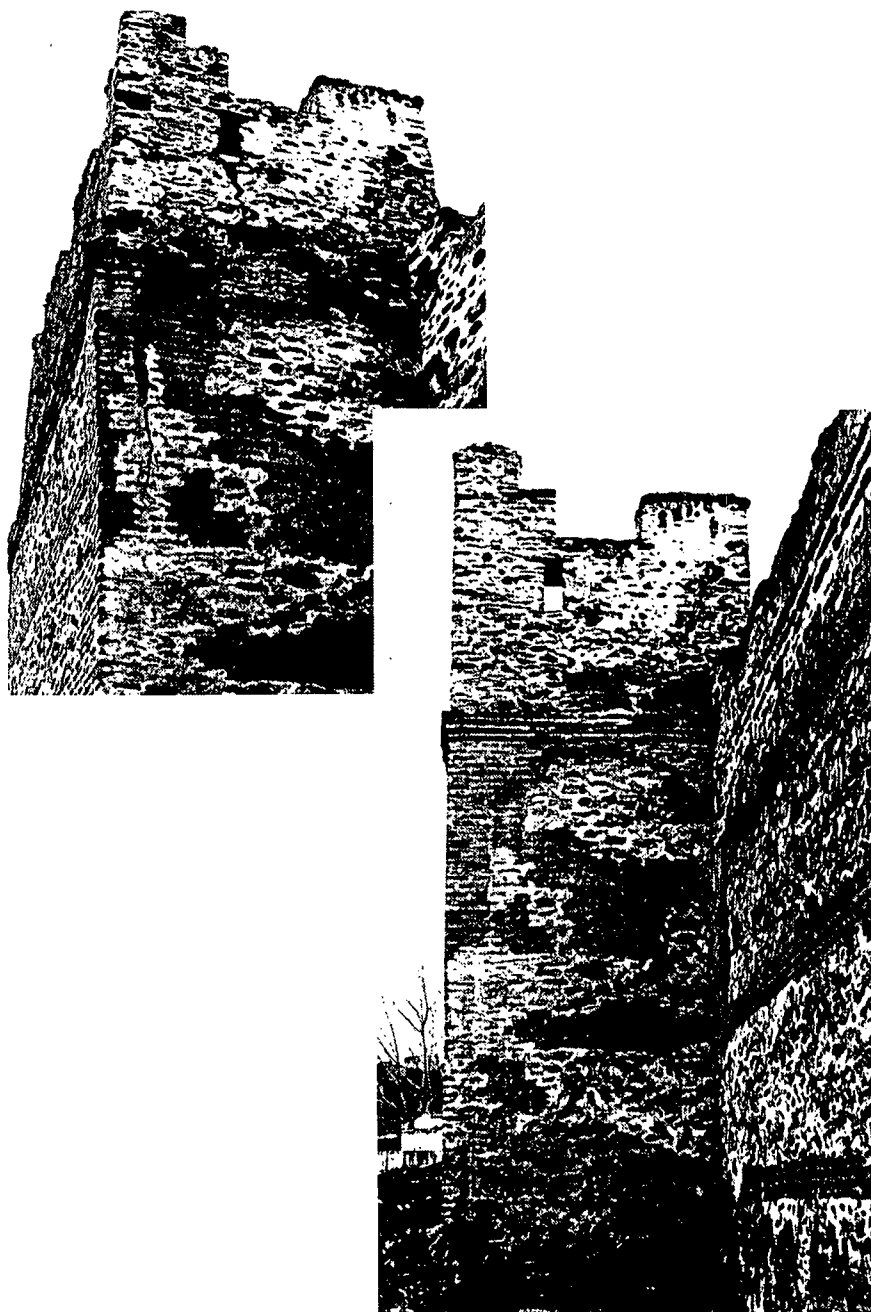

14.10 Tower 33 before and after repair, Thessaloniki

15. CASE STUDY: THE RECTOR'S PALACE, DUBROVNIK

15.1 Introduction

The Rector's Palace is one of the major cultural monuments of Yugoslavia. It has suffered damage on a number of occasions, notably in the disastrous earthquake of 1667. Concern for its safety after the earthquakes of 1962 and 1968 led to studies being undertaken between 1968 and 1974 for a possible restoration. Further damage was caused in the 1979 Montenegro earthquake. Priority was then given to its strengthening. After full investigation, a design was completed in 1981 and work started early in 1982.

15.2 Description

The first structure was erected on the site between 1387 and 1420. An explosion followed by fire destroyed part of it in 1435.

A new structure was completed in 1443, having four wings with towers at the corners and an atrium. There were three storeys and a partial mezzanine. Between the two western towers was a porch with Gothic arches on columns. Part of this structure was destroyed in its turn by another explosion in 1463, and it was then reconstructed in its present form, as seen below. Semicircular arches replaced the pointed Gothic arches of the porch, the top storey was eliminated, and the corner towers were reduced in height.



15.1 General view from the southwest

The 1667 earthquake (rated at intensity X on the MCS scale) tilted the main walls from the vertical and caused the collapse of part of the atrium. Ties were inserted to restrain the walls from tilting further, and the atrium was rebuilt with a Baroque staircase. During the Austrian occupation, new ties (seen in Figure 5.27) were inserted to support the west front, and a number of internal changes were made which affected the structural layout. The first recent strengthening measures were undertaken in 1952 after a period of neglect.

The records show that, during these vicissitudes, the western towers behaved well, and the eastern wing (which is partly connected to the sturdy town walls) suffered no serious damage. The west front (tilted outwards in 1667) and the atrium (damaged in 1520 and partly destroyed in 1667) fared less well, and the upper storey of the south wing appears to have been rebuilt after 1667.

15.3 Structural condition

At the time of the 1979 earthquake, the structural layout was less adequate than formerly. Several bearing walls had been eliminated, and there had been reconstructions with no structural logic.

The layout at ground level, seen opposite, remained sound in general, with strong cross and longitudinal walls and mainly solid floors but with some weakness introduced by the open colonnade of the west front. At mezzanine level (Figure 15.3) however, a heavy wall marked E stood on a vault below in place of the ground level walls marked A and B, and the spine wall of the south wing was missing at F. The south wall of the north tower was also weakened by a cutting for a stairway at C.

The layout of the first floor (Figure 15.4) had even less structural logic. Walls of the southeast and southwest towers were missing at G and H. So were several other walls present at ground level. Most seriously, the cross walls marked J were only light partitions, quite inadequate to stiffen the west front which was prevented from falling only by the ties. The lateral stiffness of this storey was slight and excessively dependent on the quality of the masonry and the stiffness of the timber floors and roof.

15.4 Detailed investigations

The investigations commenced in 1968-74 and continued after the 1979 earthquake included a constructional survey, studies of the soil and the foundations, surveys of cracks and deformations, and a test of the shear strength of a typical wall.

15.4.1 Constructional survey

The vertical bearing structure was found to consist of walls varying in thickness from 400 mm to 1.0 m. The typical wall had two faces of dressed stone, between which was a filling of crushed stone set in lime mortar. Some floors were carried by stone vaults and others by timber beams. Owing to successive reconstructions there was, in some places, up to 500 mm of pugging. The vaults were constructed of travertine (a light porous limestone) with a thickness at the crown of about 250 mm. Timber beams were in good condition, and there was a beam-stringer grid where spans were large. The roof was considered to be in a satisfactory condition, since it had been reconstructed

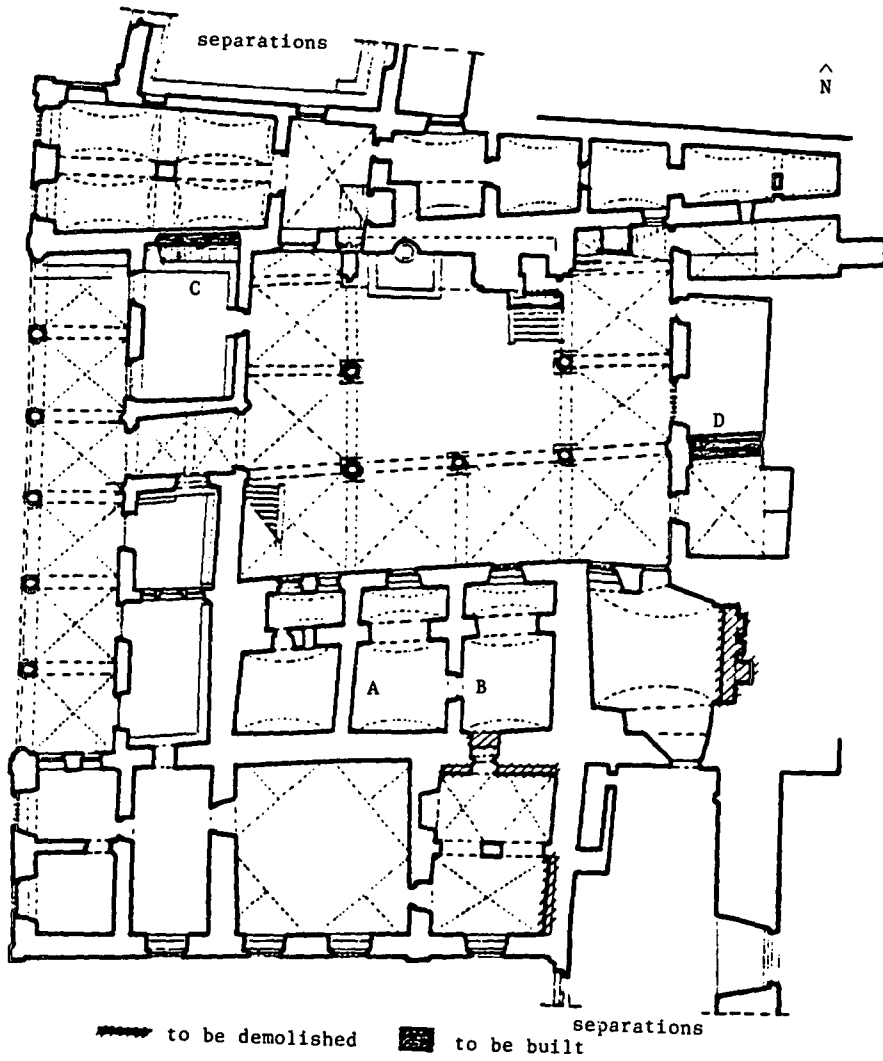

15.2 Ground plan showing demolitions and new constructions and separations (1:250)

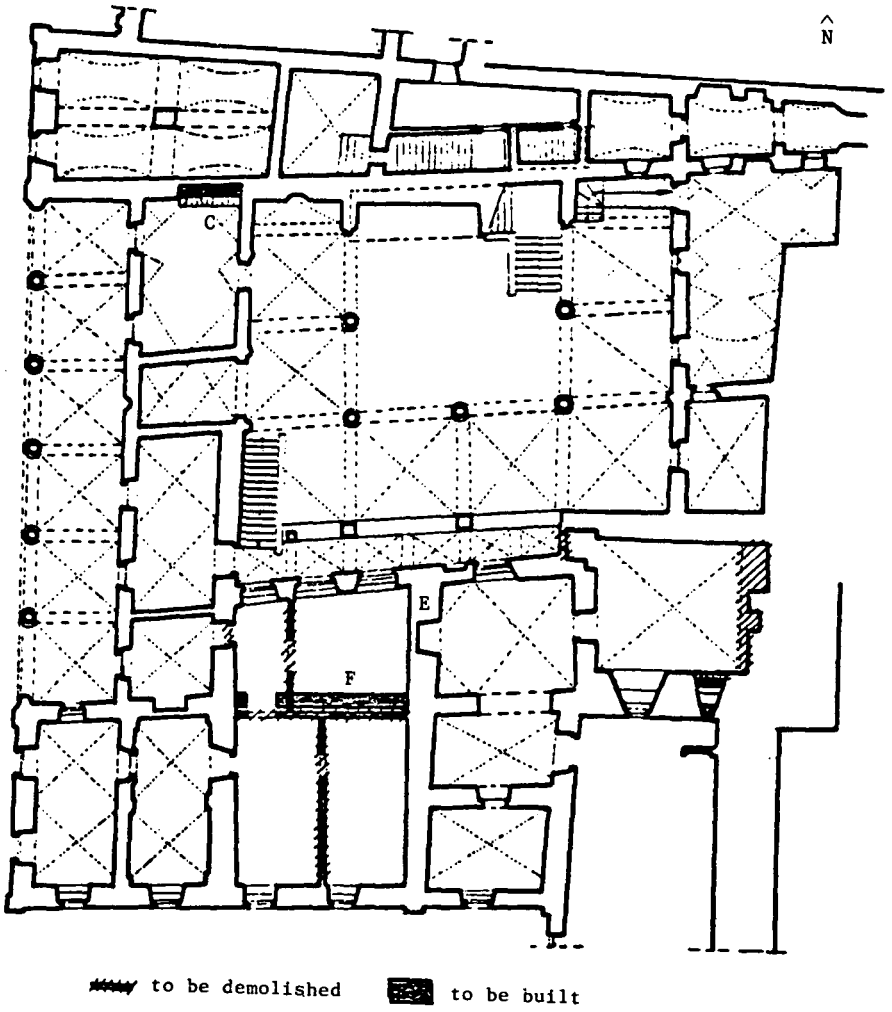

15.3 Mezzanine plan showing demolitions and new constructions
(1:250)

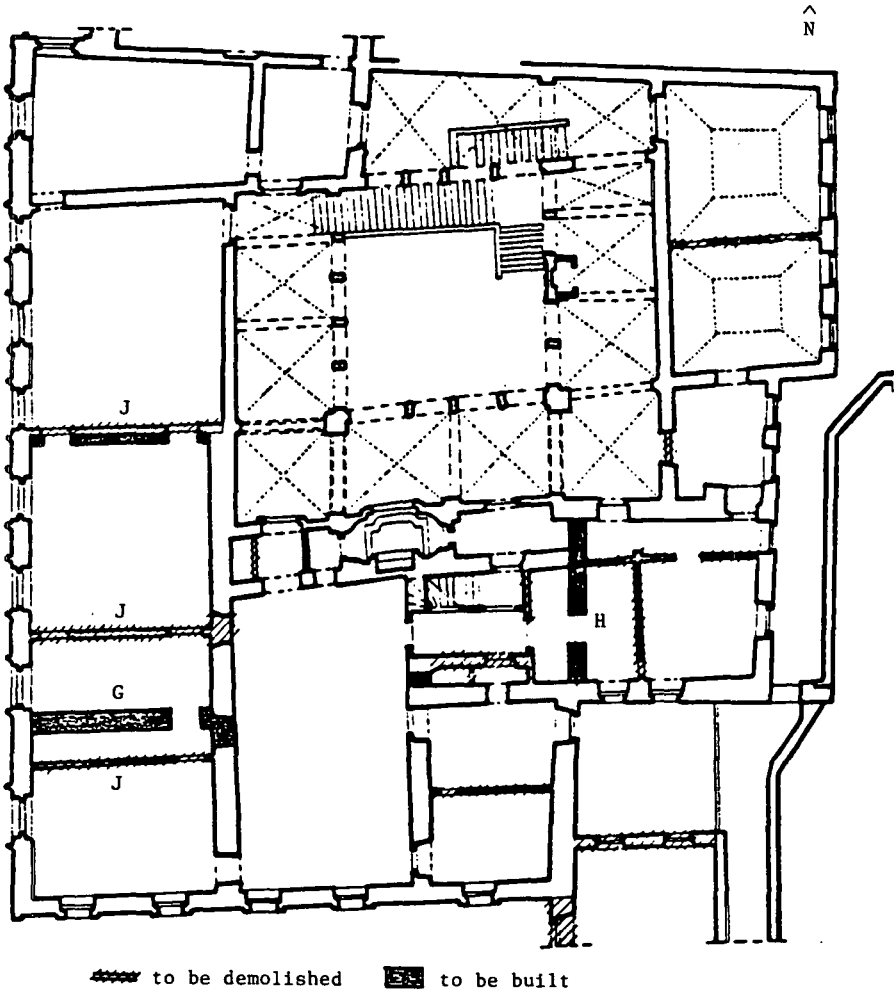

15.4 First floor plan showing demolitions and new constructions
(1:250)

in 1952.

15.4.2 Soil and foundation studies

To determine the soil and foundation conditions, five boreholes were sunk to bedrock and ten trial pits were dug alongside the foundations.

The depth of bedrock was established at between 13 and 27 m below pavement level, and the water table (fresh water, not sea water) was about 1.5 m below pavement level, i.e. about 0.75 m above sea level. The overlying soil consisted of poorly consolidated sands and clays of medium to high plasticity.

The walls and columns were found to rest on strip foundations of very varied quality. Some were constructed of roughly dressed stone bonded with a well preserved lime-and-clay mortar. Others (including those beneath the atrium columns) consisted of roughly laid irregular pieces of stone with poor, if any, bonding mortar. There seemed to be no regular pattern of footings, so that the precise condition would become known only as strengthening proceeded.

15.4.3 Survey of cracks and deformations

Numerous cracks were found on bearing and partition walls, on vaults, on some atrium columns, and on two columns of the facade. Brass marker strips were attached to several of them to permit monitoring of their widths over a five-year period. It was thereby established that they were not spreading significantly, the small movements observed being attributable to thermal expansions and contractions.

A photogrammetric survey of the west facade in 1974 had shown a horizontal displacement of up to 220 mm at the level of the first floor cornice. A repetition of this survey after the 1979 earthquake showed no significant further movement, and thereby demonstrated the efficacy of the existing ties.

15.4.4 Test of wall strength

To determine the shear strength of a typical internal wall, a section of the wall was cut free and loaded in the manner described and illustrated in section 4.3.2.

15.5 Repair and strengthening

Absolute protection against damage in a major earthquake was not considered feasible at an acceptable cost.

The primary objective, therefore, was to give the structure a better seismic resistance than it had possessed hitherto by means of a limited programme of reconstruction and other strengthening measures without doing any harm to features - such as the whole west facade - which were of chief architectural, cultural, and historical importance.

In seeking this objective, analyses of seismic response were made as a guide. In planning the work to be done it was recognised, however, that the complex past structural history made it impossible to obtain, in advance, a complete picture of the existing condition. Everyone involved was therefore warned to expect surprises, and to be prepared to give proper attention to any new findings and to reconsider what should be done from all relevant standpoints in the light of these findings.

15.5.1 Overall proposals

The overall proposals envisaged:

- re-establishing the vertical continuity of the bearing walls where this had been destroyed by previous interventions.
- strengthening of the foundations.
- improvement of the horizontal support of the west facade between the end towers.
- further improvement of horizontal diaphragm action by the introduction of reinforced concrete belt courses and diagonal ties.
- introducing seismic 'expansion joints' where other structures adjoined.

15.5.2 Detailed proposals

The construction of new stone walls was planned at C and D at ground level (Figure 15.2), at F and C at mezzanine level (Figure 15.3), and at G and H at first floor level (Figure 15.4). The new walls would be connected to the existing walls by steel anchor bars proportioned to resist seismic shear forces. Some partitions and some internal brick facing walls that had been added previously to cover areas of surface dampness would, at the same time, be removed as indicated in the same figures.

The foundations would be strengthened by casting new reinforced concrete beams alongside the existing footings of the external walls and elsewhere as indicated in Figure 15.6. The 300 x 800 mm beams would be connected to the existing footings by 20 mm diameter steel anchors, one per metre, sealed in prepared holes in the masonry with epoxy resin, as seen in Figure 5.32.

At first floor level, the west facade would be supported by means of a grid of reinforced concrete beams and steel diagonals laid over the stone groin vaults as indicated in Figure 15.7 and shown also in Figure 5.31. This grid would transmit horizontal forces to the corner towers, where reinforced concrete slabs would be provided. The atrium would be strengthened by a system of steel ties, also shown in Figure 15.7. All these reinforcements would be hidden below the existing floor levels. Connections to the existing masonry would again be by steel anchors, as shown in Figure 15.5.

At second floor level, a second stiff diaphragm would prevent future outward inclination of the upper part of the west facade and would similarly transmit horizontal forces to the end towers. Here, as seen in Figures 15.8 and 15.9, there would also be continuous horizontal ring beams linking all four wings of the building, both externally and around the atrium.

To link the horizontal diaphragms behind the west facade more effectively to this facade and give further protection to this important feature, the sections of wall between the windows would be given a 50 mm skin of gunite in the form of vertical troughs extending from one diaphragm to the other.

Seismic 'expansion joints' or separations were envisaged at two points as shown on Figure 15.2 - at the existing connections with the City Hall to the north and with a more recent building to the south above the Harbour Gate. Complete seismic isolation was not feasible because elsewhere - to the north and east - the bearing walls on the boundary are also integral parts of the

adjoining structures.

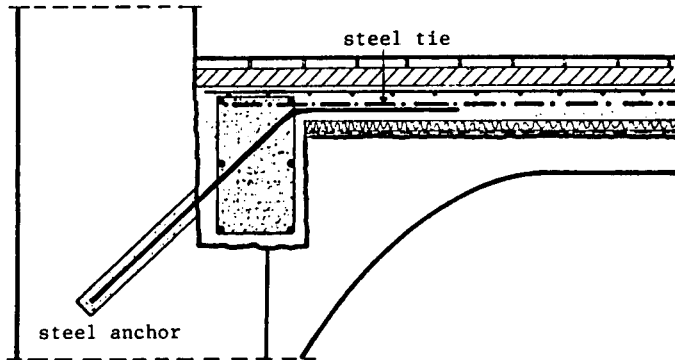

15.5 Anchorage of a horizontal diaphragm in the wall masonry

15.5.3 Analysis of seismic resistance

From the available data, the peak likely value of horizontal acceleration was assessed as 0.45 g. It was, however, possible only to speculate about the likely duration of shaking and its spectral composition. This alone seemed to preclude any attempt at a precise dynamic analysis. It was noted, on the other hand, that the peak acceleration was consistent with the overall seismic coefficient of 0.30 specified by the 1981 Yugoslav code for masonry cultural monuments in zones designated as liable to shocks of intensity IX on the MCS scale, since this coefficient gave an equivalent static load whose relationship to the peak acceleration (1:1.5) matched the ductility to be expected of a brittle masonry structure. Initial static computations of safety factors were therefore made in relation to this code coefficient.

Once the building had been structurally integrated by re-establishing the vertical continuity of the bearing walls and providing good horizontal diaphragms to transfer horizontal inertia forces to them, its seismic resistance could be assessed very simply. It was merely necessary to add together the in-plane shear strengths of the walls in each direction.

The shear strengths of the walls depend on the quality of the masonry and the vertical load which is carried. The quality of the masonry was assessed from the strength of the mortar and from the test referred to in section 15.4.4. These gave a diagonal tensile strength of 0.18 MN/m². Vertical load on the ground storey was estimated as being between 0.3 and 0.4 MN/m².

With almost identical areas of wall in the two main directions, the ultimate shear strength in each direction was assessed as 26 MN on the basis of the formula given in the manual on masonry structures. The total mass was estimated as 77.7 MN. This ultimate shear strength thus corresponded to a seismic coefficient of $26/77.7 = 0.335$, and to a safety factor of $0.335/0.30 = 1.12$ in relation to the design coefficient of 0.30.

On this basis, the safety after strengthening would still be less than was desirable, even on the assumption of completely rigid horizontal diaphragms.

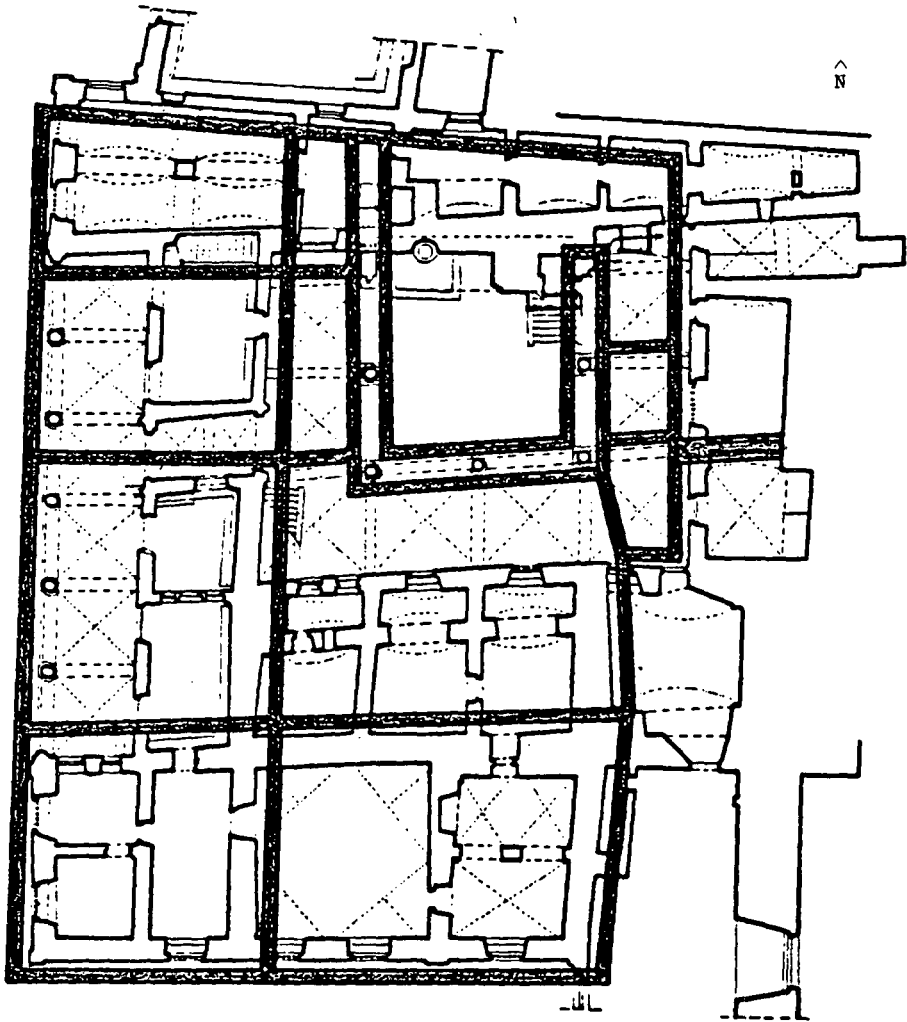

15.6 Ground floor plan showing new foundation beams
(1:250)

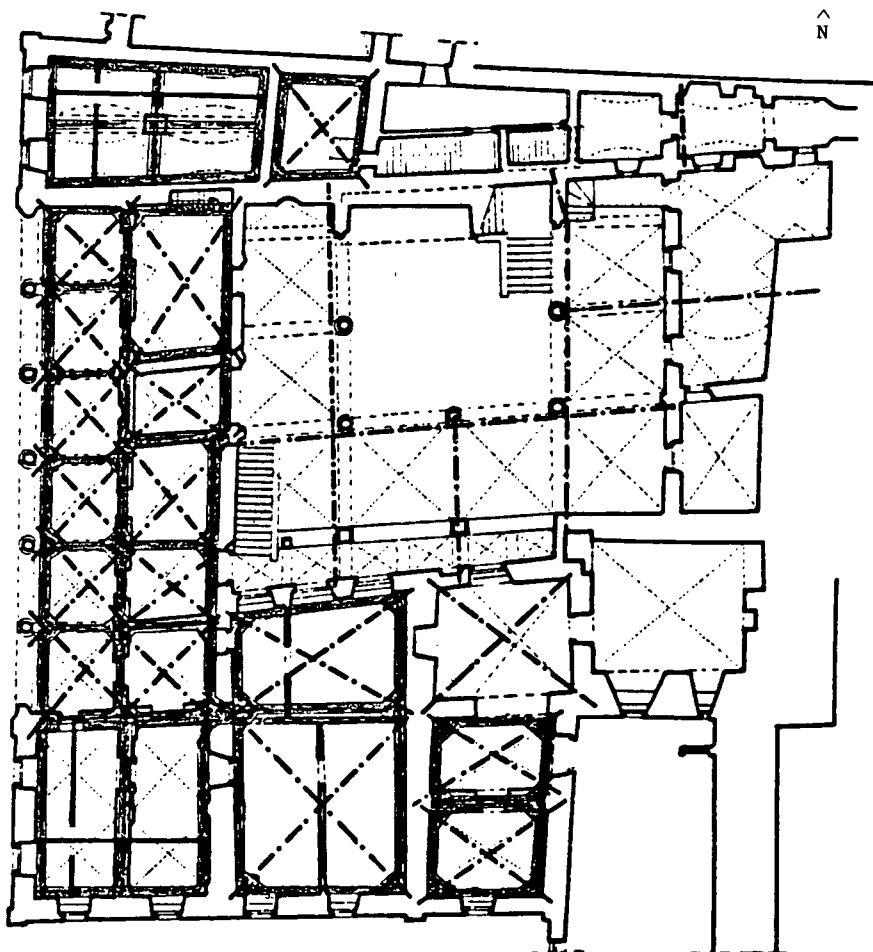

15.7 First floor plan showing new ties and diaphragm beams
(1:250)

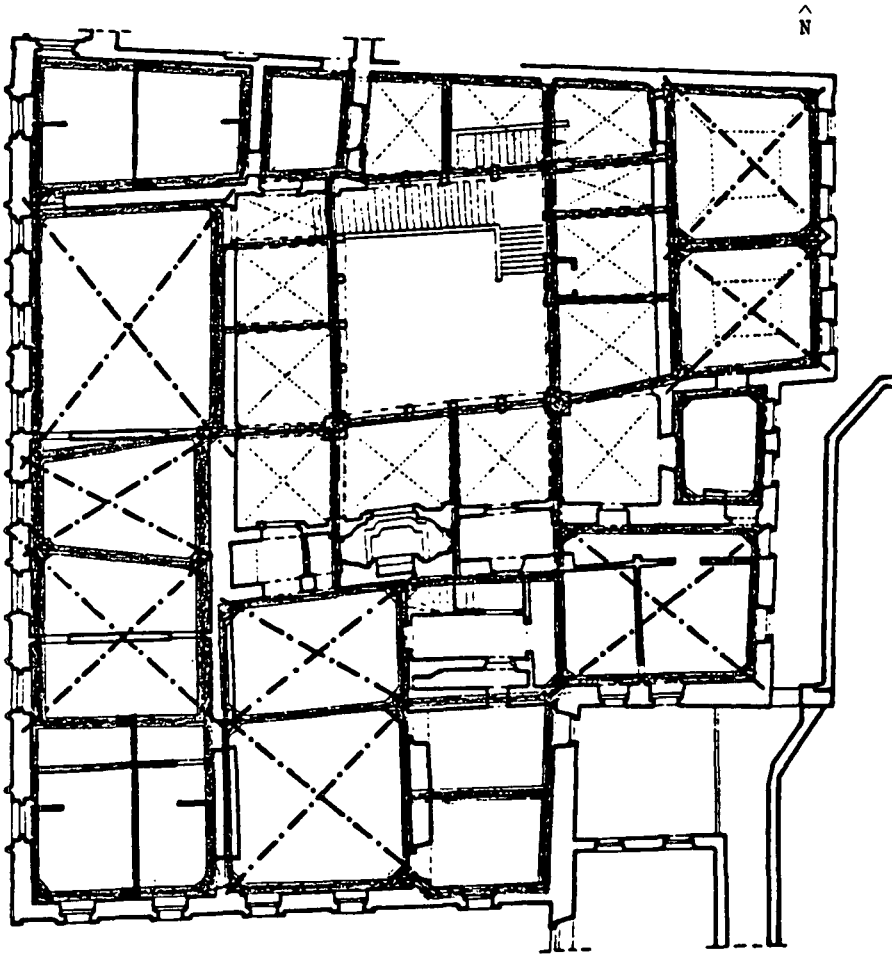

15.8 Second floor plan showing new ties and diaphragm beams
(1:250)

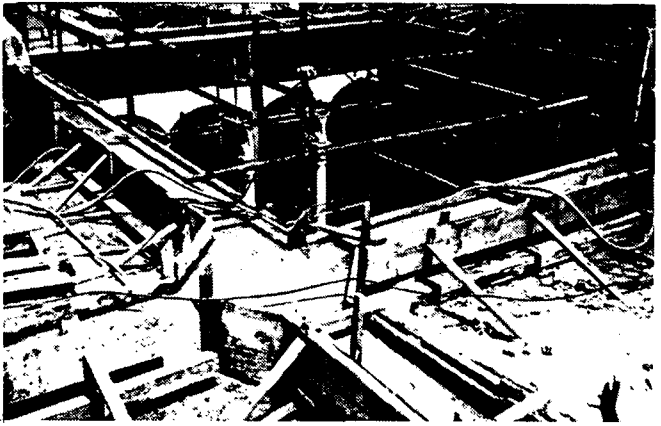
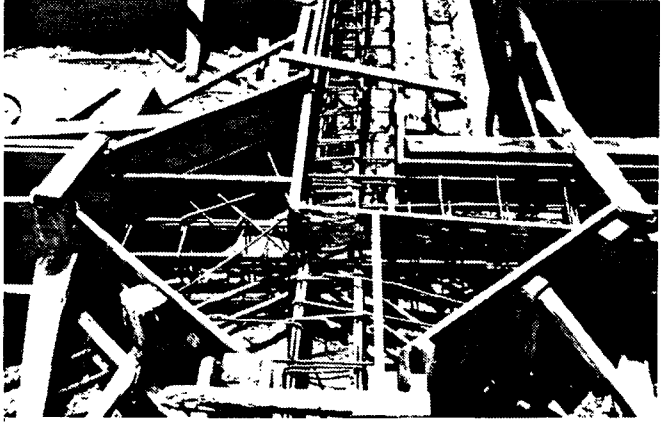

15.9 Details of the second floor diaphragm under construction

But a shock of intensity IX would be unlikely to cause major damage, and there should be a good margin ($0.335/0.15 = 2.23$) against shocks of intensity VIII. Also it was important to remember that the existing structure had already survived, since 1667, two shocks of intensity IX, eight of intensity VIII and many lesser shocks, all with moderate damage at the worst. The proposed strengthening should substantially improve on this performance in the future.

15.6 Sources

15.6.1 Sources for the text

The principal source for the text was a Yugoslav input report, 1982:

- Anicic, A, and Steinmann, V, 'Earthquake strengthening of Rector's Palace in Dubrovnik'.

This was supplemented by further information supplied by Professor Anicic.

15.6.2 Sources for the illustrations

The drawings are taken from the Yugoslav input report.

The photographs were supplied by Professor Anicic.

16. CASE STUDY: THE MARITIME MUSEUM, KOTOR

16.1 Introduction

The museum was only slightly damaged in the 1979 Montenegro earthquake. Because it was both an important building in its own rights and a museum, its structural condition and future safety were, nevertheless, of considerable concern, and several independent projects were prepared for its strengthening.

This study differs from the others in concentrating on two alternative projects rather than on the scheme finally executed. Most attention is given to the project that would have conserved most of the existing structure.

16.2 Description

The main building, seen below and towards the left of Figures 16.2 and 16.3, was constructed in the 18th century. It is of three storeys plus a basement.



16.1 View of the main frontage

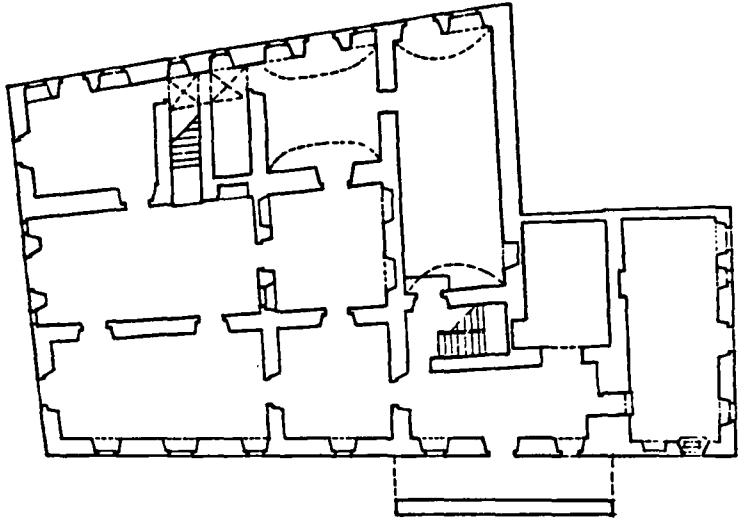

16.2 Ground plan (1:250)

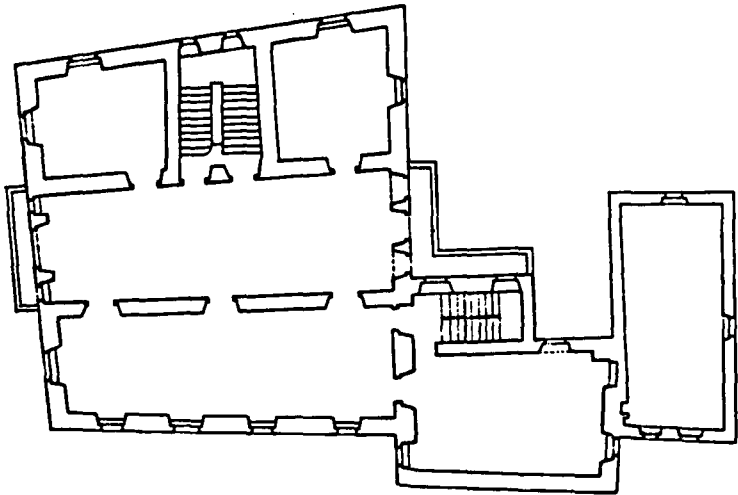

16.3 Second floor plan (1:250)

Walls are of stone, floors of timber, there was a low-pitched timber roof, and there were cantilevered balconies at first and second floor levels. As is usual in the region, external doors and windows were framed by single blocks of stone at each side, and the undersill panels were much thinner than the wall piers alongside. At some date in the past iron ties had, however, been inserted at each floor level in both directions to prevent the separations that might otherwise have occurred on the lines of the windows and doors and the outward tilting of the wall piers which these separations would have permitted.

Behind the main building is an annex, possibly of later date and of less architectural merit.

16.3 Structural condition

In the main building there was virtually no visible cracking of the external walls and no evidence of breaking of the bonds between external and internal walls or of recent foundation movements. Internally, cracking of finishes and ceilings was slight and was probably, in part, the result of previous movements. Such previous movements were the most likely reason for the insertion of the iron ties, and these ties seem to have prevented significant further movements.

Most damage had been suffered by the roof structure and by the rear annex, which had cracked away from the main building.

16.4 Detailed investigations

The detailed investigations included trial borings to ascertain the local soil conditions. These are not described further because project B involved no increase in load at foundation level, and relied on the absence of any indication of recent foundation settlements.

Some further investigation would have been desirable, chiefly of the condition of the ends of the existing timber floor beams and of the existing ties, if it had been decided to proceed with project B.

16.5 Repair and strengthening

For the present purpose, the two projects are referred to as project A and project B.

16.5.1 Project A

Project A was generally similar to the scheme adopted (in the different situation where the whole interior was remodelled) for the palace in Ulica Miha Pracata, Dubrovnik. This is described briefly in the final case study.

The project involved the replacement of all the existing timber floors by reinforced concrete slabs, a new roof of reinforced concrete, the insertion of steel ties in chases cut at each ceiling level along both the external and internal walls as shown in Figures 16.4 and 16.5, and extensive work on the foundations.

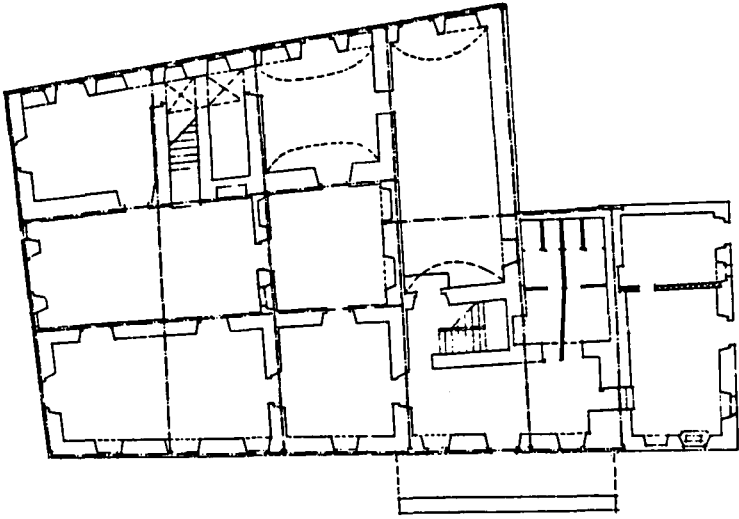

16.4 Ground plan showing proposed ties at ceiling level (1:250)

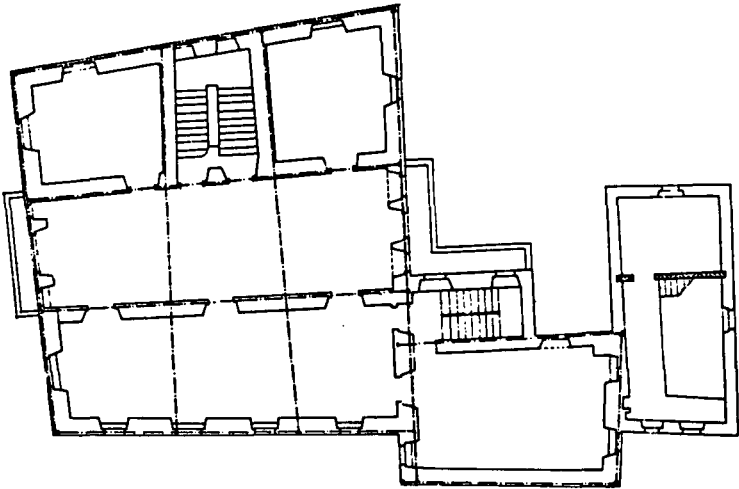

16.5 Second floor plan showing proposed ties at ceiling level (1:250)

16.5.2 Project B

The objective of this project was to obtain a significant improvement in the seismic resistance with the minimum interference with, or change in, the historical existing structure.

The main building had already demonstrated a resistance in excess of that of many structures in its immediate vicinity which had been subjected to the same shock. The chief need seemed, therefore, to be for some strengthening in relation to the principal structural weakness - that introduced by the weak interconnections between adjacent wall piers on the lines of the windows and doors. Any cutting into the wall piers, even to accommodate ties, would, in itself, weaken them. Thus it seemed best to avoid it, particularly at the corners of the building.

It was considered that the necessary strengthening could be provided by the insertion of new ties within the depth of the floors, together with some associated strengthening of the floors. The precise requirements would have been established by the further investigation referred to above. Individual floor beams could be strengthened by screwing mild steel straps to their undersides, and coating the straps with intumescent paint as protection against fire. Improved diaphragm action of the floors as a whole could be achieved by means of diagonal boarding.

It was proposed that the roof structure should simply be repaired, without adding to the total weight. Particular attention would be paid to ensuring that the rafters were adequately tied at eaves level to avoid outward thrusts on the walls. The existing foundations should then be adequate. If, on further investigation, there was any doubt about this, the existing footings could be strengthened, with minimum interference, by 'bolting on' strips of reinforced concrete as was done at the Rector's Palace, Dubrovnik.

16.6 Sources

16.6.1 Sources for the text

This study is based partly on personal inspection of the structure and consideration of the requirements and possible strengthening schemes and chiefly on a report prepared for submission by ICCROM to the Montenegrin authorities, 1982:

- Beckmann, P, 'Report on earthquake damage to buildings in Kotor, Montenegro, and recommendations for remedial works'.

16.6.2 Sources for the illustrations

Figure 16.1 is from a photograph by P Beckmann, Ove Arup & Partners, London.

Figures 16.2 to 16.5 are based on drawings supplied by the Montenegrin authorities.

17. CASE STUDY: THE HEGEMONEION, KARLOVASI, SAMOS

17.1 Introduction

The Hegemoneion is a comparatively recent structure, but one of considerable character that it is intended shall, when the present works are completed, become a cultural centre for the surrounding area. It was considered important to retain its internal form and to leave its exterior untouched. But there was less objection, in restoring it after earthquake damage in 1955 and a subsequent period of neglect, to the free use of modern materials and techniques than there is for older and historically more valuable structures.

17.2 Description

The structure was built towards the end of the 19th century as the second house of the ruler of Samos. It is of three storeys, but built on sloping ground so that it is entered directly at first floor level at the east side (Figures 17.2 to 17.5). The view below shows the full height on the west side. The architectural detailing is typical Greek neo-classical stucco.



17.1 View from the southwest before restoration

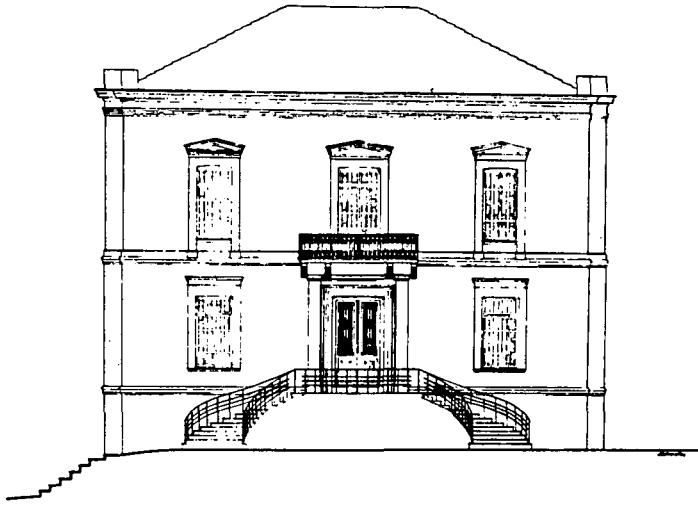

17.2 East elevation (1:200)

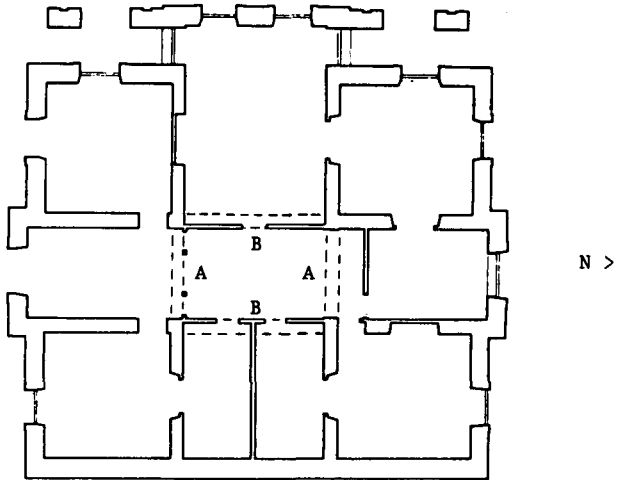

17.3 Ground plan (1:200)

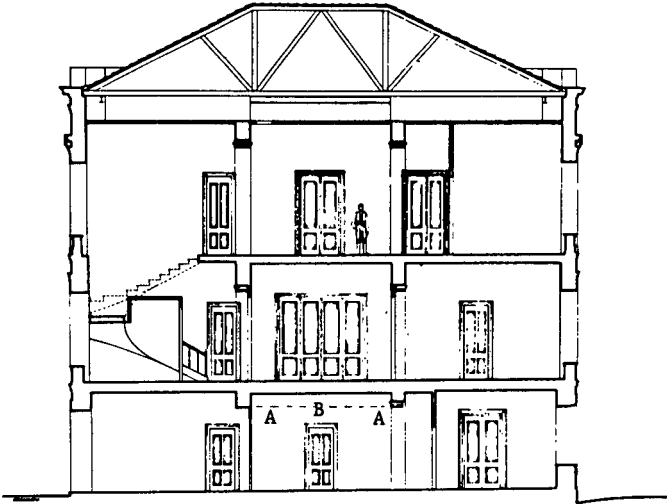

17.4 Section on the north-south axis (1:200)

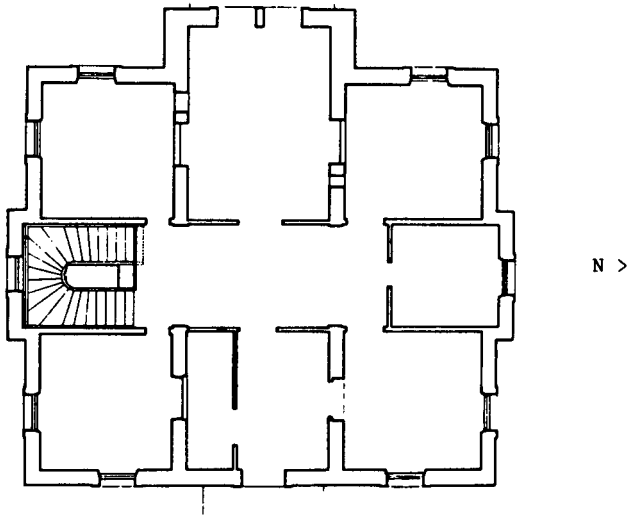

17.5 Second floor plan (1:200)

The principal walls are of mixed masonry construction, consisting of irregularly sized blocks of natural stone together with burnt brick laid roughly coursed, and with jambs and arched lintels of pure brick to most window openings. External corners are well bonded, but projecting buttresses and pilasters were left unbonded. A good hydraulic mortar was used, and it showed no signs of deterioration. Light internal partitions were timber framed, with a plaster finish.

The floors were of timber, but they were carried over the wide spans in the open centre of the building on unreinforced flat arches of brick in the east-west direction (A,A in Figures 17.3 and 17.4) and on similar brick arches reinforced by pairs of iron beams in the north-south direction (B,B in Figures 17.3 and 17.4). (See also the view during the strengthening works in Figure 5.22a.) Iron beams were also incorporated over the openings in the corner bays at ground level at the west, and there was a network of iron ties above the floor joists as seen in Figure 3.53. These linked the outer walls in both the north-south and east-west directions and assisted (originally) in developing the action of the floors as horizontal diaphragms.

The roof was carried on six timber trusses, as seen in Figure 17.4. These support purlins which are covered with boards and tiles.

17.3 Structural condition

No collapse of the walls had occurred. But there was extensive cracking, especially on the west front as seen opposite, and there were associated separations of unbonded junctions and bows and inclinations from the vertical. The cracks were up to 30 mm in width.

In several places, the horizontal timber members had lost their bearing on the walls, and the ties were mostly slack because of corrosion of the iron. Part of the roof had fallen, allowing water to penetrate and to rot the timber that was exposed to it.

17.4 Detailed investigations

As a necessary preliminary to a full examination of the damage and assessment of the structural condition, a scaffold was erected around the exterior and some temporary shores were placed under the balconies. The following investigations were then undertaken:

17.4.1 Architectural and structural surveys

An architectural survey (from which Figures 17.2 to 17.5 are taken) was made first.

Detailed surveys were then made of the cracks (as seen opposite), and of the inclinations from the vertical and other distortions and damages of the above-ground structure. To disclose the full extent of the cracks, the surface stucco was removed as necessary.

The materials used, including the mortar, and the type of masonry construction were also inspected, especially in regions where damage had occurred.

To determine the character of the foundations, some exploratory excavations were made. These showed that the walls rested on simple footings about

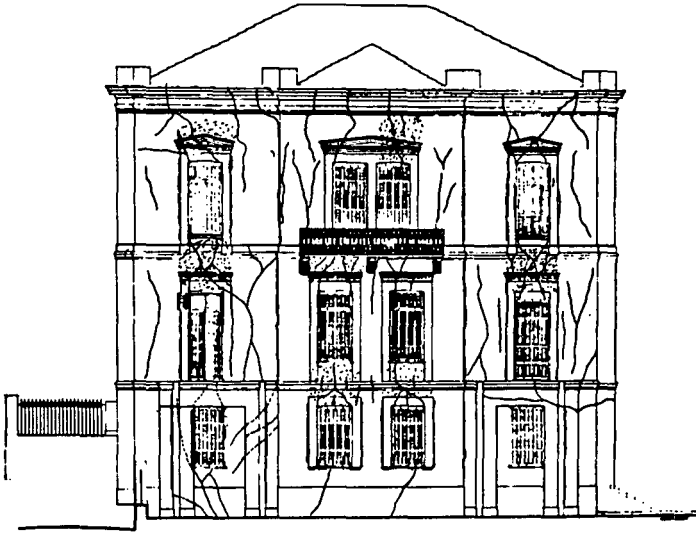

17.6 Cracking and other surface damage on the west elevation (1:200)

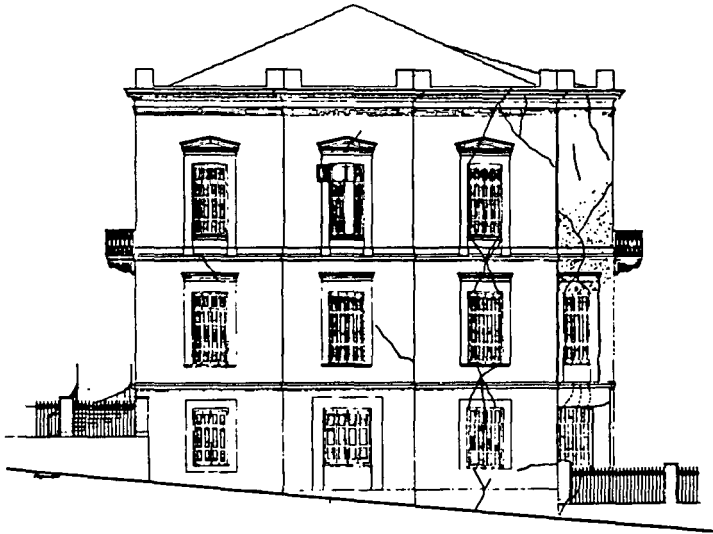

17.7 Cracking and other surface damage on the north elevation (1:200)

1.2 m below basement level and slightly wider than the walls themselves.

17.4.2 Structural assessment

The reasons for the extensive damage to the west front were then considered.

The principal reason was clearly the pronounced lack of symmetry about the north-south axis at the two lower levels. In particular:

- there was little connection at these levels between the projecting bays of the west front and the walls behind.
- the central opening in the wall immediately behind was not effectively bridged.
- the closely spaced window openings and poor construction detailing of this front introduced further weaknesses.

17.4.3 Static analysis

A static analysis showed that, even if the walls were assumed to be uncracked, the structure did not have the seismic resistance called for by current codes for a building intended for public use involving heavy floor loadings.

17.5 Repair and strengthening

Considerable strengthening, in addition to simple repair of the damage, was therefore considered necessary. But the desirability of retaining the internal form and the original exterior that was referred to in the introduction meant that there could be no substantial change in the structural layout for the purpose of obtaining a more symmetrical distribution of resistances.

It was proposed to achieve the increase in strength in the following ways:

- by removing excess mass, especially at roof level.
- by restoring, as far as possible, the initial strengths of the walls by grouting.
- by enhancing these strengths, and the diaphragm strengths of the floors, with the minimum increases in mass.
- by increasing the bearing capacity of the foundations to the extent necessitated by such increases in mass as were unavoidable.

17.5.1 Grouting of the walls

Grouting was undertaken in the normal manner, using a cement grout with PVAC emulsion and a pure epoxy resin for the finest cracks which the cement grout would not penetrate.

Where there were separations at unbonded junctions, the two sections of wall were first tied together by means of steel bars threaded through holes drilled for the purpose and then anchored in place by injections of resin in the holes.

After grouting, the penetration of the grout was confirmed by drilling cores,

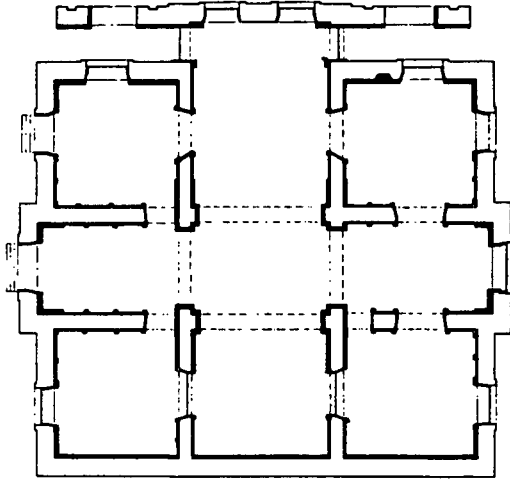

17.8 Strengthening of the walls at ground level (1:200)

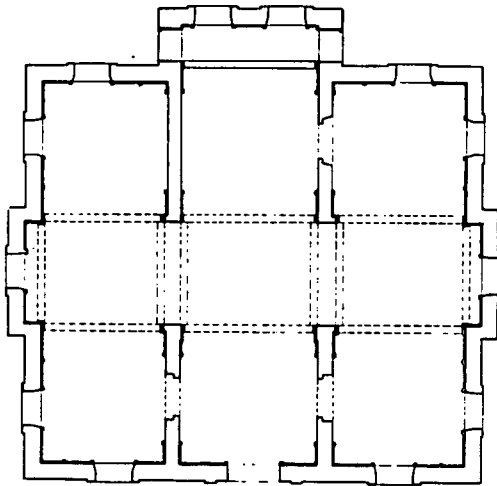

17.9 Strengthening of the walls at first floor level (1:200)

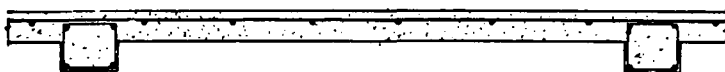

17.10 Typical horizontal section of the shotcrete wall skin (1:10)

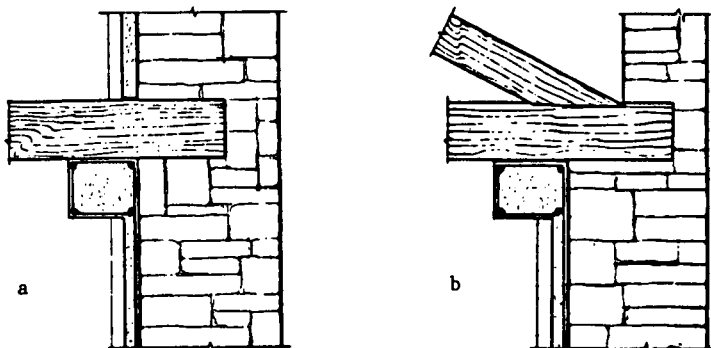

17.11 Typical vertical sections at floor and roof levels (1:20)

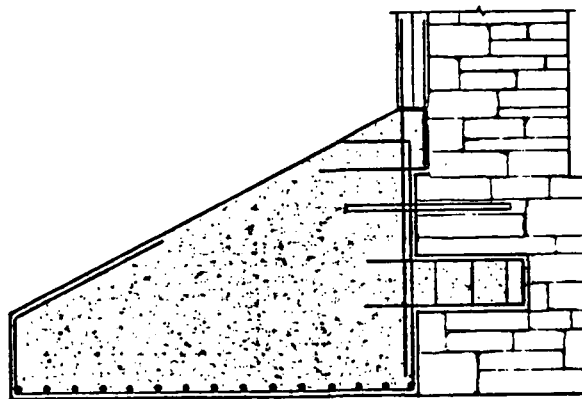

17.12 Typical vertical section of the foundation strengthening (1:20)

60 mm in diameter.

17.5.2 Strengthening of the walls and floors

All bearing walls were then strengthened by adding skins of reinforced shotcrete. The skins were 50 mm thick, with projecting ribs, 50 x 100 mm, to form columns 100 mm square as called for by the Greek regulations and shown in Figure 17.10. These skins were added to the inside faces only of the external walls and to both faces of the internal walls. They were designed to carry the whole seismic shear of 0.16 x gravity load.

The positions of the skins at ground level and first floor level are shown in Figures 17.8 and 17.9, while Figures 5.21 and 5.22a show reinforcement in place prior to spraying of the shotcrete.

The procedure was:

- holes were drilled in the masonry, one per m², and shear dowels were fixed in the holes by injecting resin.
- any remaining plaster and other loose material was removed from the surface.
- the surface was sand blasted and then saturated with water.
- the reinforcement was fixed.
- the shotcrete was sprayed, as seen in Figure 5.22b.

To improve the diaphragm action of the floors, a grid of reinforced concrete beams was simultaneously formed around the walls just below each set of floor beams, as shown in Figure 17.11a. These reinforced concrete beams also provided supplementary support to the floor beams.

A similar grid of reinforced concrete beams was formed just beneath the roof trusses, as shown in Figure 17.11b.

In addition, new steel ties were placed within the depth of each floor and at roof level.

17.5.3 Strengthening of the foundations

To bear the additional loads from the shotcrete wall skins, additional concrete strip footings were poured alongside the existing footings as necessary. These were dowelled to the existing footings as seen in Figure 17.12, and linked to the shotcrete wall skins by means of projecting starter bars.

17.6 Sources

17.6.1 Source for the text

The source for the text was a Greek input report, 1983:

- Miltiadou, A, and Yiourousis, A, 'Restoration and strengthening of the "Hegemoneion" Building in Karlovasi, Samos'.

17.6.2 Sources for the illustrations

The illustrations are taken from the report or based on working drawings supplied by Miss Miltiadou.

18. CASE STUDY: BUILDINGS OF LESS INDIVIDUAL IMPORTANCE

18.1 Introduction

The buildings considered here are those whose cultural, historical, or architectural importance stems less from their individual characters than from the urban groupings of which they are members or from the fact that they represent an important traditional type that is in danger of disappearing.

Most of them are smaller structures than those considered in previous studies and of more recent construction - dating from either the last century or the early part of this century. And most of them are used, in part at least, as dwellings. This use calls for a stricter conformity with code requirements than is appropriate for some monuments. But their smaller individual importance and relative youth make the adoption of the methods of repair and strengthening described in the manual on repair and strengthening of reinforced concrete, stone and brick-masonry buildings more directly applicable.

Because there will be large numbers of buildings of these kinds calling for attention after an earthquake and they will usually belong to a few structural types, it will be particularly desirable to consider alternative approaches. Since it has not been possible to illustrate this with a single study, the most relevant available details are presented for several cases.



18.1 Dubrovnik: many buildings contributing to an important ensemble

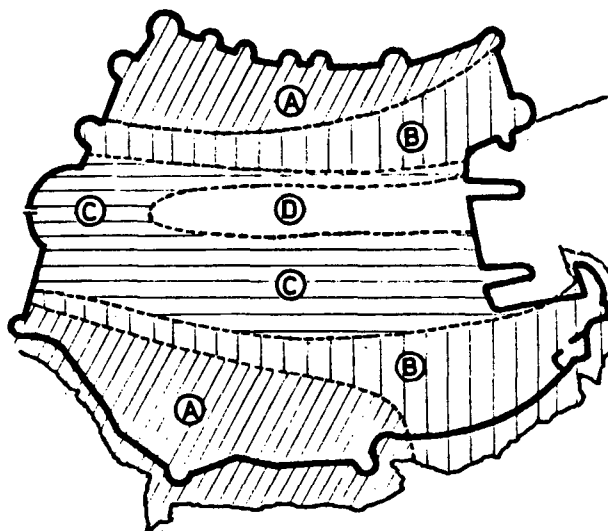

18.2 Seismic microzoning of Dubrovnik old town (1:5000)

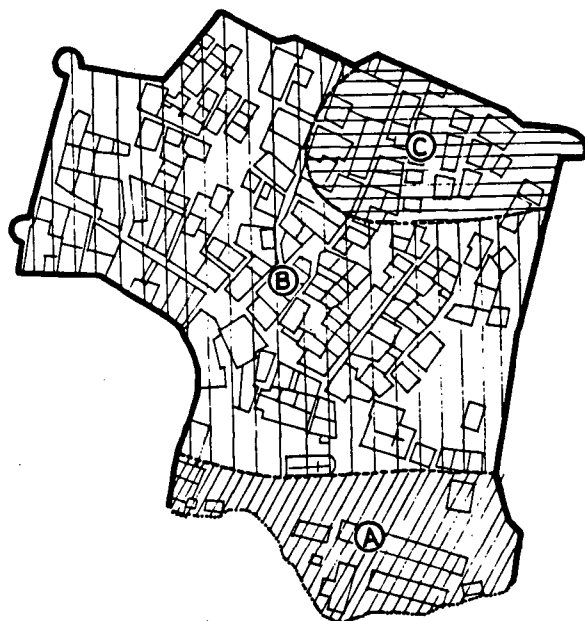

18.3 Seismic microzoning of Budva old town (1:2500)

18.2 Overall considerations including seismic hazard

The chief requirement, apart from making the buildings safe for occupation, has usually been to preserve the external appearance and character. Ideally this should be done in ways such as those described in earlier studies. But this is likely to be more difficult and costly than complete or partial internal reconstruction or even complete reconstruction reproducing the previous exterior. Overall policy decisions are necessary here. One policy has been to adopt the less costly alternative in general, but to repair and strengthen a few buildings at public expense in conformity with the stricter principles discussed in sections 2.1.2 and 2.1.3, and thereby to preserve some authentic examples of each traditional type.

For the determination of seismic loading, full account should be taken of local variations in the ground and consequent variations in seismicity. Figures 18.2 and 18.3 show the microzoning adopted for the old urban centres of Dubrovnik and Budva.

18.3 Building in Ulica Miha Pracata, Dubrovnik

18.3.1 Description

This building, seen below and in Figures 18.5 and 18.6, stands in a district



18.4 Ulica Miha Pracata, Dubrovnik

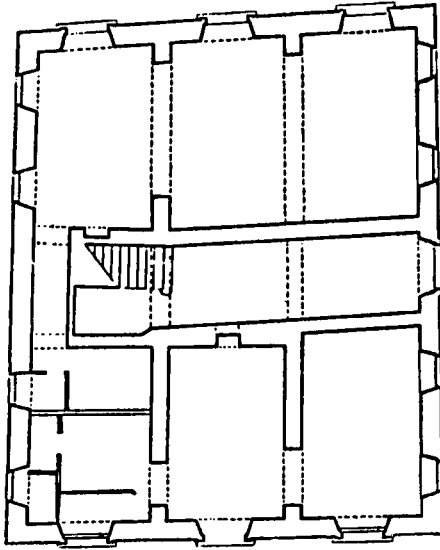

18.5 Building in Ulica M Pracata, Dubrovnik, ground plan (1:200)

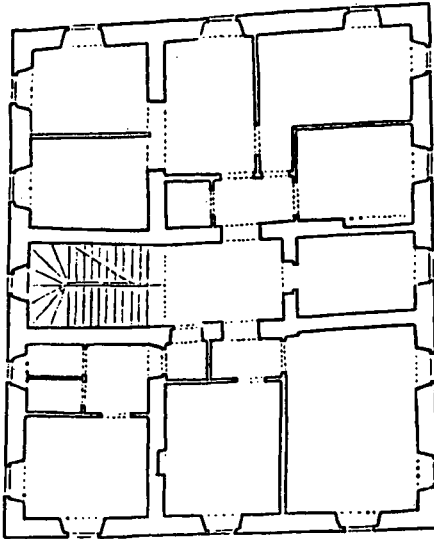

18.6 Building in Ulica M Pracata, Dubrovnik, first floor plan (1:200)

already developed for residential and commercial use in the 12th century, although it is essentially a structure of the 18th and 19th centuries. Having served various uses in the past, it was restored with the intention of using it in future as a museum.

18.3.2 Structural condition

After the 1979 earthquake, the bearing walls of stone masonry showed some cracking as seen below and associated small deformations. The timber floors and roof were largely in good condition. But the structural layout was inadequate to develop the seismic resistance appropriate to its intended new use.

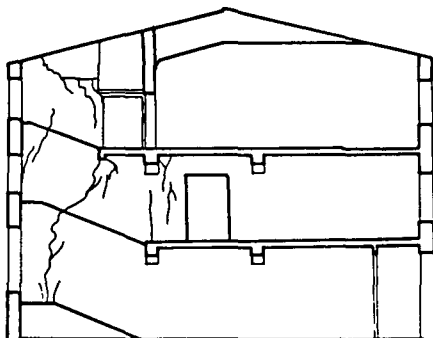

18.7 Building in Ulica M Pracata, Dubrovnik, section (1:200)

18.3.3 Repair and strengthening

It was decided to retain and repair only the external walls. Internally, a new structure of reinforced concrete walls will be built as shown in Figures 18.8 and 18.9, with reinforced concrete floor slabs. The external walls will be strengthened by applying 50 mm skins of reinforced gunite anchored to the masonry by steel bolts and to the new internal structure by reinforced concrete collar beams at floor levels. The timber roof will be replaced by a reinforced concrete one similar in form.

New reinforced concrete foundation beams will be constructed as required alongside the existing footings and connected to these.

For the repair of the external walls it is intended to grout only those cracks wider than 0.5 mm, since adequate strengthening will be provided by the gunited skins.

18.4 Buildings in Budva

18.4.1 Description

Most of the area of the old walled town that is marked B or C in Figure 18.3 is densely built upon with two-, three-, and four-storey houses, many with shops or similar premises at ground level.

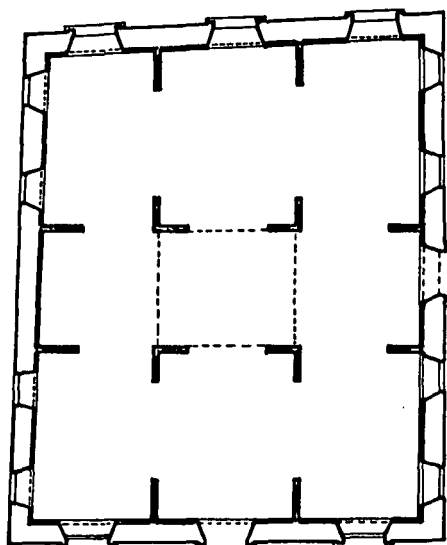

18.8 Building in Ulica M Pracata, Dubrovnik, ground plan (1:200)
showing new internal structure

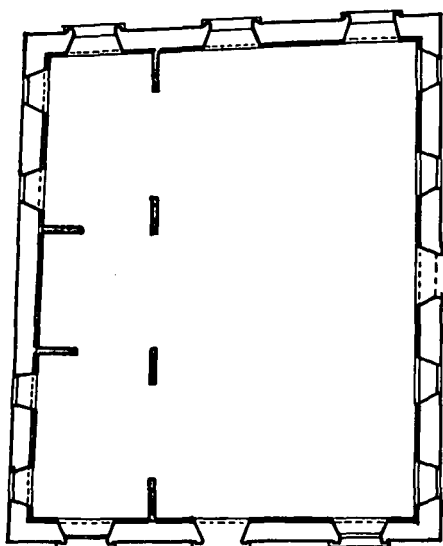

18.9 Building in Ulica M Pracata, Dubrovnik, first floor plan (1:200)
showing new internal structure

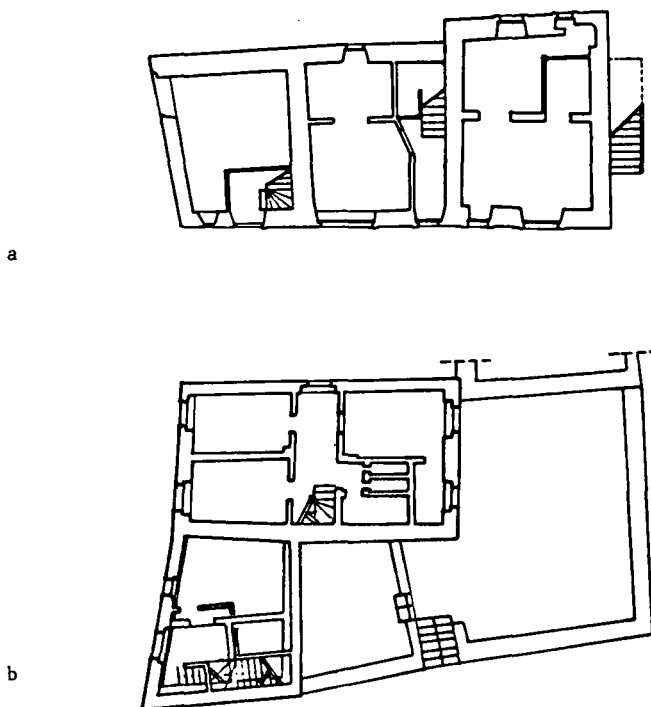

18.10 Plans of typical building blocks, Budva old town (1:200)

Individual buildings abut directly on one another to form irregularly shaped blocks as seen above and in Figure 18.3.

The bearing walls are constructed of stone masonry set in lime mortar. On the faces, or at least on the quions, the blocks are roughly dressed. In the core, smaller rubble is used. A characteristic feature of the external walls has been noted already in the description of the Maritime Museum at Kotor. This is the framing of the door and window openings by single upright slabs of stone at each side and the great reduction in thickness at the undersill panels. Floors and roofs are of timber, the latter with tile coverings.

The buildings are not of great architectural merit. But, together and with the enclosing wall, they constitute a very fine ensemble. After the 1979 earthquake it was considered important to restore this and bring it back to life, while retaining as far as possible its historical character.

18.4.2 Structural condition

The town suffered badly in the earthquake. Few buildings escaped damage. Some partly collapsed. Most suffered varying degrees of cracking of the external walls and associated damage to the floors, roof, and roof coverings.

Cracking of the external walls was concentrated in the weak undersill panels,

as seen below and (when further developed) in Figure 3.89. The corners, however, were usually undamaged and were clearly the strong points of the structure which had prevented more extensive collapses where cracking was severe.



18.11 Damaged buildings, Budva old town

Further damage to the floors unfortunately occurred subsequently as a result of rain entering through the damaged roofs.

18.4.3 Repair and strengthening

Since no two buildings were identical in form and in structural condition, all required individual assessment and attention. A consistent overall approach was, nevertheless desirable.

One approach would have been essentially that which was described as Project B for the Maritime Museum in Kotor (see section 16.5.2). In principle, this would have been to recognise fully the strengths of the existing structures, and to supplement them as simply as possible where necessary. The chief need would have been for more effective interconnections between the stronger

sections of wall. This could have been achieved by repairing and stiffening the existing timber floors and introducing new cross ties within the depths of the floors. Depending on the condition and the original disposition of the walls, there would probably have been a further need for some local strengthening by grouting or for the construction of some new sections of wall.

The proposal prepared by the Skopje Institute of Earthquake Engineering and Engineering Seismology (IZIIS) envisaged, on the other hand, the replacement of all the existing timber floors by slabs of reinforced concrete. Connection of these slabs to the existing walls would necessitate some cutting into the walls as shown below. But it was also proposed to strengthen all walls by grouting, to strengthen them further by the application of internal reinforced concrete skins where this seemed necessary, and to build new walls of stone-faced concrete in some cases. An example with a typical detail are shown in Figures 18.13 and 18.14. This further strengthening would reduce the risk of damage from the introduction of the reinforced concrete floors that was referred to in section 5.7.5.

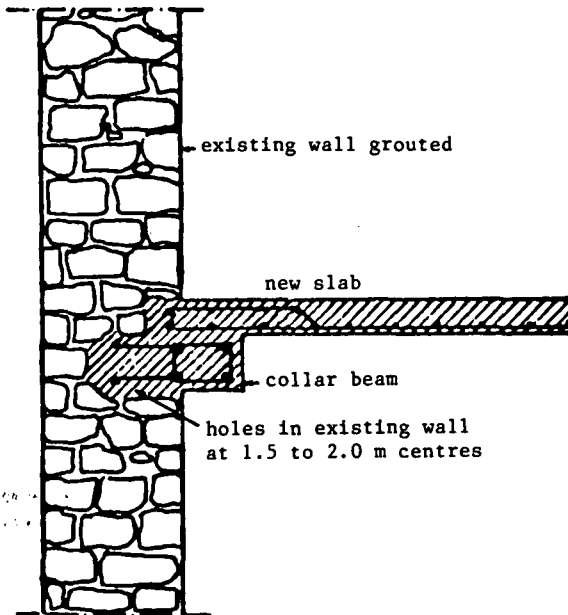

18.12 Detail of connection of floor slab to existing wall, Budva (1:20)

To determine the precise requirements for each building, the total shear resistance of the walls would be calculated on the basis of experimentally determined unit strengths and compared with the design values of the seismic shear forces appropriate to the location of the building. The reinforced concrete floor slabs would be assumed to provide effectively rigid interconnections at each floor level.

Checks would also be made on the soil stresses at foundation level and, where

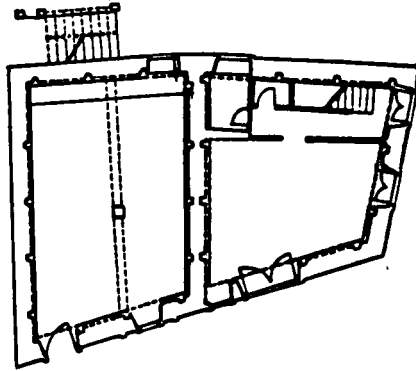

18.13 Building in Budva showing proposed strengthening (1:100)

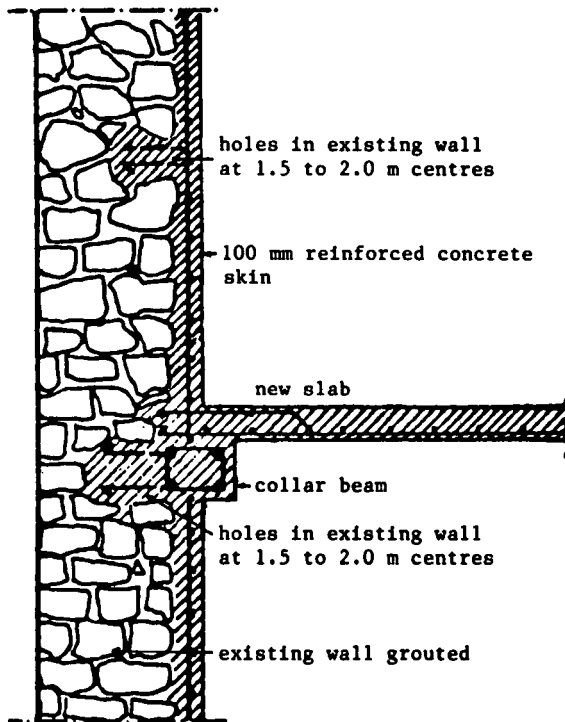

18.14 Detail of wall strengthening and floor slab, Budva (1:20)

necessary, the foundations would be strengthened by casting new reinforced concrete beams alongside the existing footings.

18.5 Rural dwelling house in Lusevera (Friuli)

This example perhaps belongs more properly in the manual on the repair and strengthening of reinforced concrete, stone and brick masonry buildings, since it illustrates a procedure that would require some modification if applied to a building whose external appearance was important and if it were intended to be long lasting.

It is included, nevertheless, because it is the only example that it is possible to present of a recent intervention that has already been tested by a major subsequent shock. The only feature that would require modification is the manner of tying.

18.5.1 Description

The building of chief interest is the three storey dwelling illustrated in Figures 18.15 to 18.18. The walls are of uncoursed stone rubble bound with lime mortar, with facings of larger stones and smaller stones in the core. Originally the floors were all of timber, but some had been replaced by pre-fabricated ceramic flooring. Some lintels were of wood, others of reinforced concrete. There were no ties. The roof was of timber with a covering of heavy tiles.

18.5.2 Structural condition

The building was severely damaged in the earthquake of May 1976. There was extensive cracking of all bearing walls and partitions and separations at all corners and intersections. It was initially condemned for demolition.

18.5.3 Repair and strengthening

It was however reprieved and was partially repaired and strengthened before the further shocks of September 1976.

The work undertaken was the grouting of all bearing walls and the installation of ties on both sides of each wall at each floor level as shown in Figures 18.15 to 18.17. Typical details are shown in Figures 8.31 to 8.33 of the manual on the repair and strengthening of reinforced concrete, stone and brick masonry buildings, and Figure 8.30 of that manual shows the application of the same method of strengthening to the building illustrated here in Figure 18.10a.

The ties were installed first in chases cut in the wall plaster. When the ties had been tensioned against the anchor plates, the nuts on their threaded ends were spot welded and the masonry was grouted with cement and pozzolana.

The roof was removed for remodelling and strengthening. But the September shocks intervened.

18.5.4 Behaviour in the subsequent shocks

Grouting was completed in August and the strengthened structure was tested the following month by shocks of a similar intensity to the shocks that caused the previous damage. It survived undamaged, as seen in Figure 18.18.

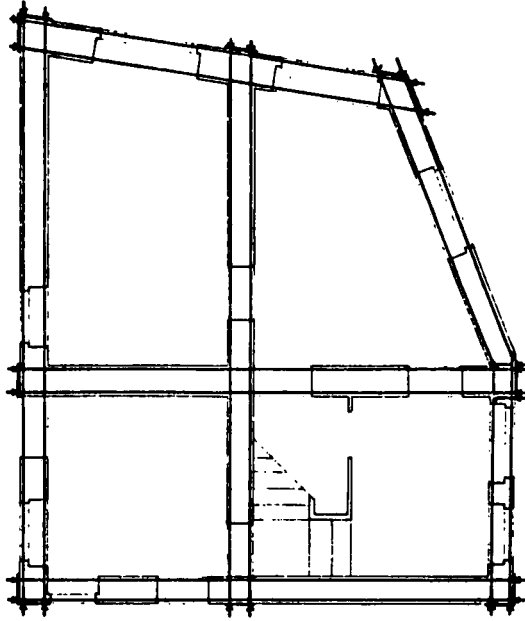

18.15 Building in Lusevera, ground plan showing ties (1:100)

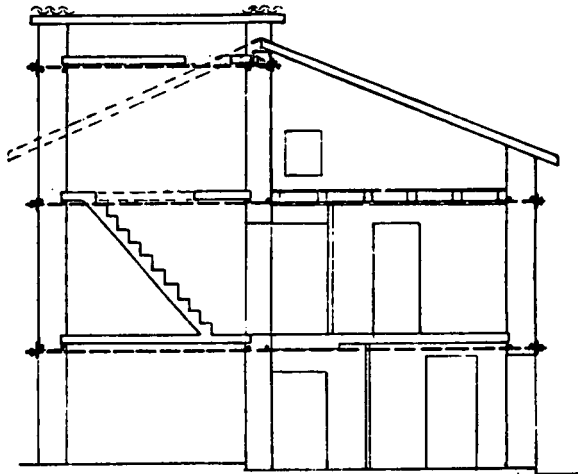

18.16 Building in Lusevera, section showing ties (1:100)

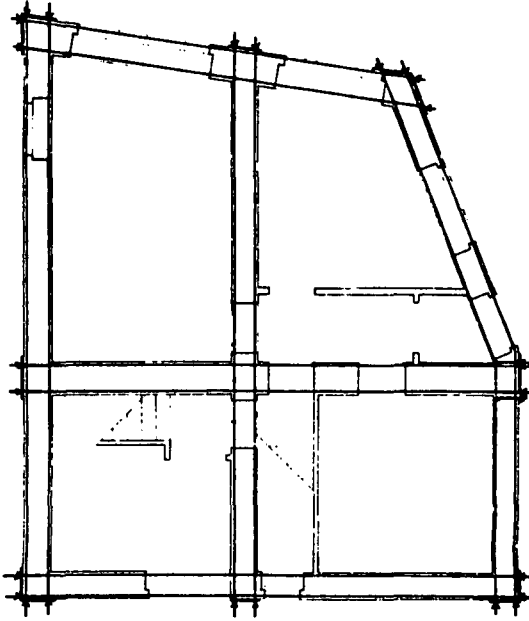

18.17 Building in Lusevera, first floor plan showing ties (1:100)



18.18 Building in Lusevera after the September 1976 earthquakes

18.6 Timber framed dwelling houses

The many types of timber framed dwellings found in the region present broadly similar problems and similar choices of method for repair and strengthening. The chief example chosen as an illustration is a typical Bulgarian form.

18.6.1 Description

The form is illustrated below and in Figure 3.87.

The ground floor is constructed with walls of thick stone masonry, often reinforced with bonding timbers and with good bonding between longitudinal and transverse walls. Seismically, it can be regarded as providing a rigid base for the framed upper floor.

Typical framing of a wall of the upper floor is shown at b below. The joints rely to some extent on iron nails and clamps. Usually the frame is filled with either burnt or unburnt brick and the whole surface, both inside and out, is plastered or boarded.

18.6.2 Structural condition

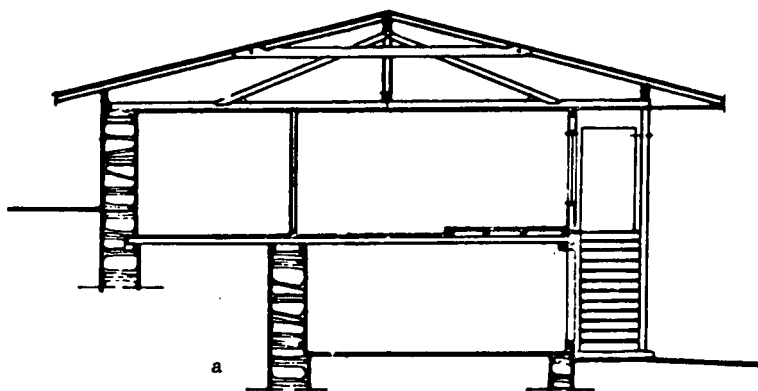

cross section

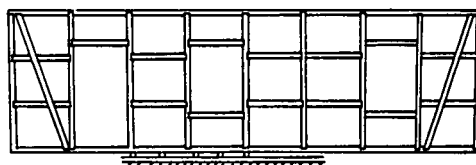

framing of a storey-height wall

As was noted in section 3.18, the seismic performance is usually good if the structure is in good repair. Damage usually stems from decay of the timber, which may lead to serious deformations and loss of strength of the walls.

18.6.3 Repair and strengthening

The basic choice is between a repair that restores the structure to a state close to its original undamaged state and a partial reconstruction that substitutes or adds other bearing elements of steel or reinforced concrete without altering the outward appearance. The former will also often involve a partial reconstruction, but one that uses materials and details similar to the original after suitable preservative treatment.

In Bulgaria, the former method is used for buildings considered to be of national importance, and the latter for buildings of less importance or buildings where it is considered to be impracticable to achieve the desired performance by the former method. A group of buildings recently restored is shown below.

A similar procedure has been followed in some other countries. Figure 3.88 shows reconstruction in the former manner in progress in Istanbul.

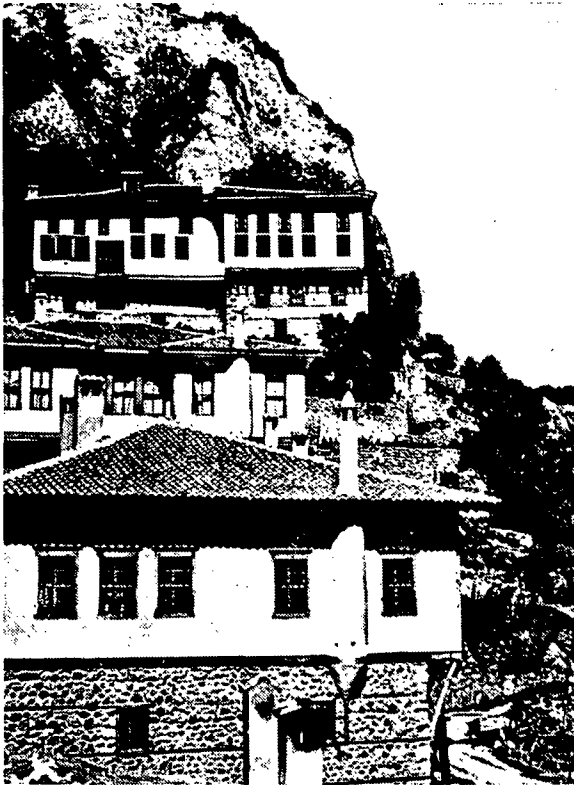

18.20 Typical houses restored

18.7 Sources18.7.1 Sources for the text

Section 18.3:

- Zamolo, M, 'Earthquake strengthening of the palace in Ulica M Pracata, Dubrovnik', Yugoslav input report, 1983.

Section 18.4:

The principal source for the text was a Yugoslav input report, 1983:

- Velkov, M, 'Repair and strengthening in the old town of Budva'.

This was supplemented by notes on personal inspections and assessments of the damaged structures and on possible approaches to repair and strengthening, 1980:

Section 18.5:

- Tomazevic, M, 'Strengthening and repair of rural stone-masonry dwelling houses: Case study'. Yugoslav input report, 1983.

Section 18.6:

- Venkov, V, 'Seismic effect on buildings from the 'Popular' national architecture', Bulgarian input report, 1983.
- Venkov, V, Todorov, T, and Georgiev, K, 'Structural problems of adaptation of Bulgarian Renaissance houses for contemporary uses', Monumentum, XV-XVI, 1977, 148-51.

18.7.2 Sources for the illustrations

Figures 18.1 and 18.4 were supplied by Professor Anicic.

Figure 18.2 is based on a plan in the Yugoslav input report referred to in chapter 15.

Figures 18.3, 18.10, 18.12, 18.13, 18.14 are adapted from drawings in the Yugoslav input report by Professor Velkov referred to above.

Figures 18.5, 18.6, 18.8, 18.9 are adapted from drawings in the Yugoslav input report by Mrs Zamolo referred to above.

Figure 18.7 is from IZIIS report 81-76.

Figure 18.11 is from a photograph by the consultant.

Figures 18.15, 18.16, 18.17 are from the Yugoslav input report by Mr Tomzevic referred to above.

Figure 18.19a is from the article in Monumentum referred to above.

Figures 18.19b and 18.20 are from the Bulgarian input report by Professor Venkov referred to above.

18.7.3 Additional reference

The following paper describes other works of repair and strengthening in the Friuli after the 1976 earthquakes, and is worth consulting alongside the study in section 18.5:

- Benedetti, D, 'Riparazione e consolidamento degli edifici in muratura', reprinted by Masson Italia, Milan, 1981, from Costruzioni in zona sismica, 1981.

BUILDING CONSTRUCTION UNDER SEISMIC CONDITIONS
IN THE BALKAN REGION

Volume 6: Repair and strengthening of historical monuments
and buildings in urban nuclei

Corrigendum

The scales indicated on graphs and figures in this publication do not apply because the originals have been reduced.

Page 108

At the bottom of the page insert

- 5.11. Parapet of defense wall damaged after repair, Castle of Heraklion