



TOGETHER
for a sustainable future

OCCASION

This publication has been made available to the public on the occasion of the 50th anniversary of the United Nations Industrial Development Organisation.



TOGETHER
for a sustainable future

DISCLAIMER

This document has been produced without formal United Nations editing. The designations employed and the presentation of the material in this document do not imply the expression of any opinion whatsoever on the part of the Secretariat of the United Nations Industrial Development Organization (UNIDO) concerning the legal status of any country, territory, city or area or of its authorities, or concerning the delimitation of its frontiers or boundaries, or its economic system or degree of development. Designations such as “developed”, “industrialized” and “developing” are intended for statistical convenience and do not necessarily express a judgment about the stage reached by a particular country or area in the development process. Mention of firm names or commercial products does not constitute an endorsement by UNIDO.

FAIR USE POLICY

Any part of this publication may be quoted and referenced for educational and research purposes without additional permission from UNIDO. However, those who make use of quoting and referencing this publication are requested to follow the Fair Use Policy of giving due credit to UNIDO.

CONTACT

Please contact publications@unido.org for further information concerning UNIDO publications.

For more information about UNIDO, please visit us at www.unido.org

06184

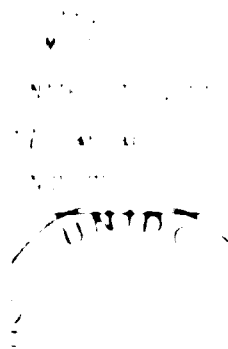

▲ A. ...

BY

... Vienna ...

* Independent producers and consultants to the Industrial Information Section, UNIDO, Vienna.

The following manual gives the names of some of the firms which are known to manufacture and/or trade in audio-visuals, but the list should not be regarded as exhaustive. Inclusion in this manual does not imply any recommendation by UNIDO. The views and opinions expressed are those of the consultants and do not necessarily reflect the views of the Secretariat of UNIDO. This document has been reproduced without formal editing.

At the same time, the...
...
...
...

C o n t e n t s

Note to the Reader	page iii
PART ONE: USING AUDIO-VISUALS	
Chapter 1. First Principles	1
Chapter 2. Selection	11
Chapter 3. Utilization	45
PART TWO: TECHNIQUES AND TOOLS	
Chapter 1. Non-Projected Aids	61
Chapter 2. Voice Production	77
Chapter 3. Projected Still Pictures	81
Chapter 4. Motion Pictures	113
Chapter 5. Electronic Media	133
PART THREE: APPENDICES	
A. Selected Books and Periodicals	150
B. Distributors of United Nations Publications and Other Books	157
C. Institutions and Organizations	164

ANNEX 1

After the first draft has been prepared, the manual will be reviewed by a group of experts, including representatives from the industrial sector, to ensure that the manual is relevant and useful.

During the review process, it is expected that the manual will be revised to take into account the comments and suggestions of the experts. The manual will be prepared in a format that is suitable for use by the industrial sector, and will be distributed to the relevant organizations and individuals. The manual will be available in both English and Spanish, and will be available to all interested parties. The manual will be available in both English and Spanish, and will be available to all interested parties. The manual will be available in both English and Spanish, and will be available to all interested parties.

When the use of a manual is being considered, it is important to ensure that the manual is relevant and useful. The manual should be reviewed by a group of experts, including representatives from the industrial sector, to ensure that the manual is relevant and useful.

This manual is aimed at persons at the level of the industrial sector, and is intended to assist in extending the use of a manual in the industrial sector. It is also expected that the manual will be useful to persons who make better use of some of the techniques mentioned in the manual. Ideally, the manual is aimed at the persons at the level of the industrial sector, and is intended to assist in extending the use of a manual in the industrial sector. It is also expected that the manual will be useful to persons who make better use of some of the techniques mentioned in the manual. Ideally, the manual is aimed at the persons at the level of the industrial sector, and is intended to assist in extending the use of a manual in the industrial sector.

Readers of this first draft are asked to respond with suggestions and criticism as to how to improve the final draft of the manual. They are asked to send their evaluation and comments to the Director, Industrial Information Section, United Nations Industrial Development Organization, P.O. Box 113, A-111 Vienna, Austria.

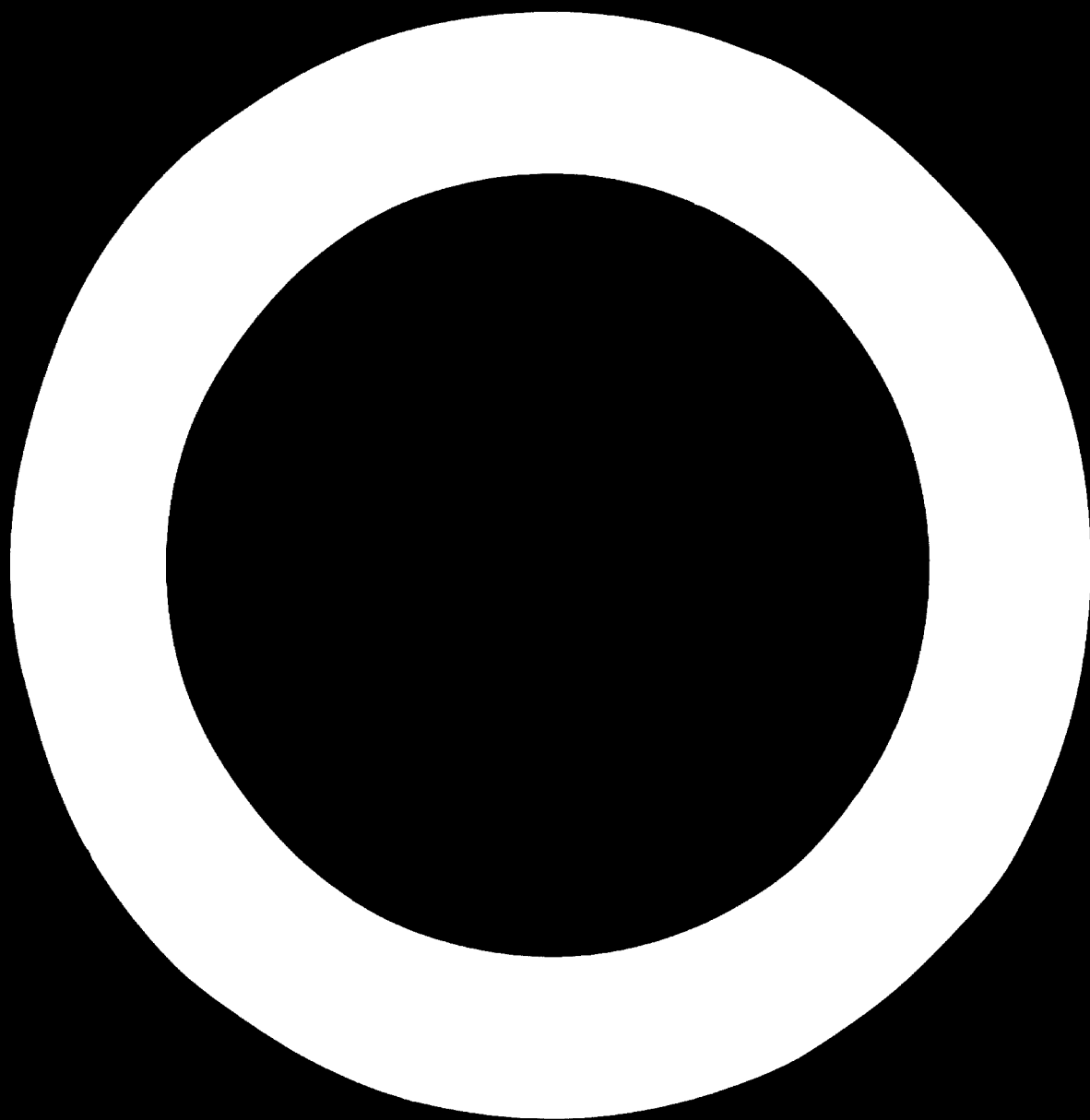

AUDIOVISUAL TECHNIQUES
FOR
INDUSTRY

PART ONE

Using Audiovisuals

CHAPTER ONE

First Principles

Industry always needs the best possible techniques available for conveying information, skills and ideas. This is particularly true in developing countries where industrialisation is proceeding at a particularly fast speed, but it applies everywhere just as strongly. In the last few years it has been discovered, or rediscovered, that audiovisual techniques can give by far the best methods of teaching. With all the new equipment, materials and learning programmes that are now in use, audiovisuals can now accelerate any learning process to a high degree of efficiency.

"Audiovisual" is a word with many definitions. In some areas of education - for instance in language teaching - it can mean a particular type of instruction in which there is a close one-to-one correspondence between picture and spoken word. In very general use, "audiovisual" can refer to any kind of equipment or materials (hardware or software) which makes use of either sound or pictures or both rather than just printed words on a page.

In this manual, "audiovisual" has a definition somewhere between these two meanings. We are concerned with methods of presentation in which any kind of sound and any kind of picture are used together. Our "audiovisuals" are the tools with which we present information audiovisually.

Audiovisual presentations have a vast number of different forms. At one extreme, you are using audiovisuals when you draw a map while telling a tourist how to get to an address. At another extreme, you can use a bank of slide and film projectors, involve your students with close-circuit television, operate an overhead projector and a multiboard, and record the whole thing on videotape for subsequent playback and discussion. The techniques you use will depend on their cost-effectiveness in relation to the kind of information you want to convey and the learning level of students/trainees. A large number of techniques will be described here, but first we must offer a brief history of their development and a general guide to the best procedures for making sure that a presentation achieves the best possible retention of information by the learner.

History

For centuries civilized man attached greater importance to writing and printing than to any other form of visual communication. Presumably this is partly because the written language is the oral equivalent form of speaking. The only equivalent for visual expression is the private activity of thinking.

The general belief was that words were superior to visual images in communication, and that they involved a higher level of intelligence and thought. Education in developed nations is still firmly rooted in this belief and the production of visual materials such as films, diagrams, and picturegrams is often held to be a craft activity quite separate from the process of thinking. This is in spite of the fact that great scientists like Galileo, Copernicus, Newton and Leonardo da Vinci, who sowed the seeds of modern technology, expressed their thoughts through visual images and symbols. These were the only ways in which they could communicate their findings.

It is a well known fact that in the areas of the world where the supremacy of the written language is not dominant, there is a much stronger tradition of visual communication. In many countries expression through drawings and pictures has always been the means of handing traditional crafts and skills on to the new generation.

Young children all over the world express themselves through drawings and paintings before they learn to read and write: this is a part of human behaviour which is only too easy to lose at a later age. Professional communicators should realise this, but unfortunately not all do. There are still many who teach exclusively

through the use of words. The present educational system is still producing large numbers of teachers who are literate, but only a few can be said to take full advantage of audiovisual aids.

Nevertheless audiovisuals in their most modern form - the moving picture with sound - have been used ever since the invention of cinematography. As far back as 1907, a film was made for the Huntley and Palmer biscuit factory to show how biscuits are made. Until the arrival of "talkies", the sound was provided at the point of projection - and it still is with many modern 8mm film loops.

Here we must offer a word of explanation for why such a majority of "audiovisual aids" are in fact purely visual aids in their own mechanics. The big difference between audio and visual aids is that a teacher can make a visual aid into an audiovisual aid just by talking, whereas he would have a hard job to draw on the blackboard fast enough to keep up with an audio aid! The fact is that the growth of audiovisuals has largely related to the development of moving pictures.

The use of the film medium as a means of training, apart from entertainment, rapidly expanded during the First

World War and became indispensable during the Second World War. Nevertheless it only became a universally appreciated medium with the introduction of the 16millimetre and eventually the 8millimetre film in both standard and super format.

The production of inexpensive projectors in 16 and 8 millimetre sizes enabled thousands of schools, training institutions and industrial organisations to own and operate them without needing to employ a professional projectionist. It also meant that well-made documentary and instructional films were readily available at any given time on their own premises.

During the same period the natural successor to the early magic lantern, the film-strip, became more sophisticated by acquiring synchronised sound, and firmly established itself as a basic audiovisual tool. So, too, has a newer form of visual aid, the overhead projector, which is used alongside numerous variants of the conventional chalkboard.

Retention and Memorisation

Whatever process an audiovisual message goes through - electronic, photographic, or magnetic - before it

reaches the student, the most important thing about it is that it reaches his eyes and ears. To make best use of audiovisual techniques, it is necessary to know the procedures by which perception can be as clear as possible, and memorisation as complete as possible.

It has been shown that a man retains 10% of the information he reads, 20% of what he hears, and 30% of what he sees. He remembers 50% of what he hears and sees, and 70% of what he hears, sees, and then discusses. Another study has indicated that the use of audiovisuals can reduce required learning time by 40% and increase retention of the information by 20%.*

These studies are an important validation of audiovisual techniques. It is even more important to know the procedures by which audiovisual techniques can be most effective. There has been some research into this, though there is much more to be learnt.

Major industrial corporations such as the Ford Motor Company in the United States, and the Shell Petroleum Company in Europe, have engaged prominent psychologists to study the effectiveness of audiovisual instruction.

* These percentages are the result of a compilation of American research into the effectiveness of audiovisuals.

They have come to a certain amount of agreement on the processes by which knowledge is absorbed through the human senses.

Instruction can be divided into three phases:

- 1 - imparting some comprehension of a main point.
- 2 - the explanation of detail and the imprinting of this on the memory.
- 3 - encouraging practical experience.

These three elements fit naturally into the sense channels. Comprehension by sight, explanation by words and experience by touch. Each phase seems to have a major sense channel, but there are other factors to be taken into consideration, for instance:

- a) maximum efficiency in instruction is achieved by using all sense channels;
- b) vision has a more enduring effect on memory than hearing;
- c) the memory needs cultivation and stimulation;
- d) the three phases of training must be carefully co-ordinated.

In practice each separate phase must make use of all three sense channels - but in a varying degree, depending on the instructional objective.

Apart from the industrial organisations which have carried out trials to determine the best methods of audiovisual instruction compared with conventional oral methods, there are also government agencies, scientific institutions and the Services, which have made full use of visual teaching in their instruction systems and training curricula.

The overall conclusion is that without doubt visual methods are superior in giving comprehension, that the audiovisual method is more effective than the spoken word in teaching details, and that visual methods are the most successful in imprinting information on the memory.

THE RANGE OF TOOLS

Due to the wide range of available hardware, the choice of the right tool is no mean task. The choice of software may be even more difficult. There is a genuine shortage of the right type of material to gear a presentation to the best advantage in most teaching situations.

Before considering the range of audiovisual tools in detail it may be useful to divide them into two major sectors:

- 1) mechanical aids
- 2) simple aids.

The first category consists of filmstrips, slides, tape recorders, record players, overhead projectors, diasscopes, episcopes, radio and television, and all types of motion picture. Electricity supply is essential to provide the power to use these.

Non-projected aids consist of various types of display boards: chalkboard, markerboard, flannelboard, magnetboard and others. Non-projected aids do not depend on power supply. Because of this they may be more convenient in some circumstances, but they rely on the lecturer's continuous presence, and on his personal performance.

AUDIOVISUAL TECHNIQUES
FOR
INDUSTRY

PART ONE

Using Audiovisuals

CHAPTER TWO

Selection

SELECTION

The charts on pages 10, 11 and 12 express the principles of this chapter in graphic terms. In chart (1) we see that training is often the last resort in solving production problems. In chart (2) we see that training by programmed instruction involves a great deal of preparation work, and in chart (3) that Media Selection is the last decision in scientific learning programmes.

So by the time you get to choose the media necessary to good implementation of a learning programme, the problem which led to the learning programme has probably been kicked around by a lot of people in the organisation. You are their "last chance" - and this gives you special responsibilities and privileges. First of all, it gives you the duty to say that if you think an audiovisual programme will not work in your particular context, there is no point in selecting media for it. You have to have the courage of your convictions, even when they are negative. And your superiors must accept that they have given you a responsible job which gives you the right to say no.

This situation is usually rare, fortunately, for the range of training needs that can be implemented with

Identify work problems

Specify objectives

Job re-design ?

Make arrangements

Reformulate objectives

Personnel selection ?

Make arrangements

Reformulate objectives

Training ?

Make training programme

Apparently unattainable objectives

Start again

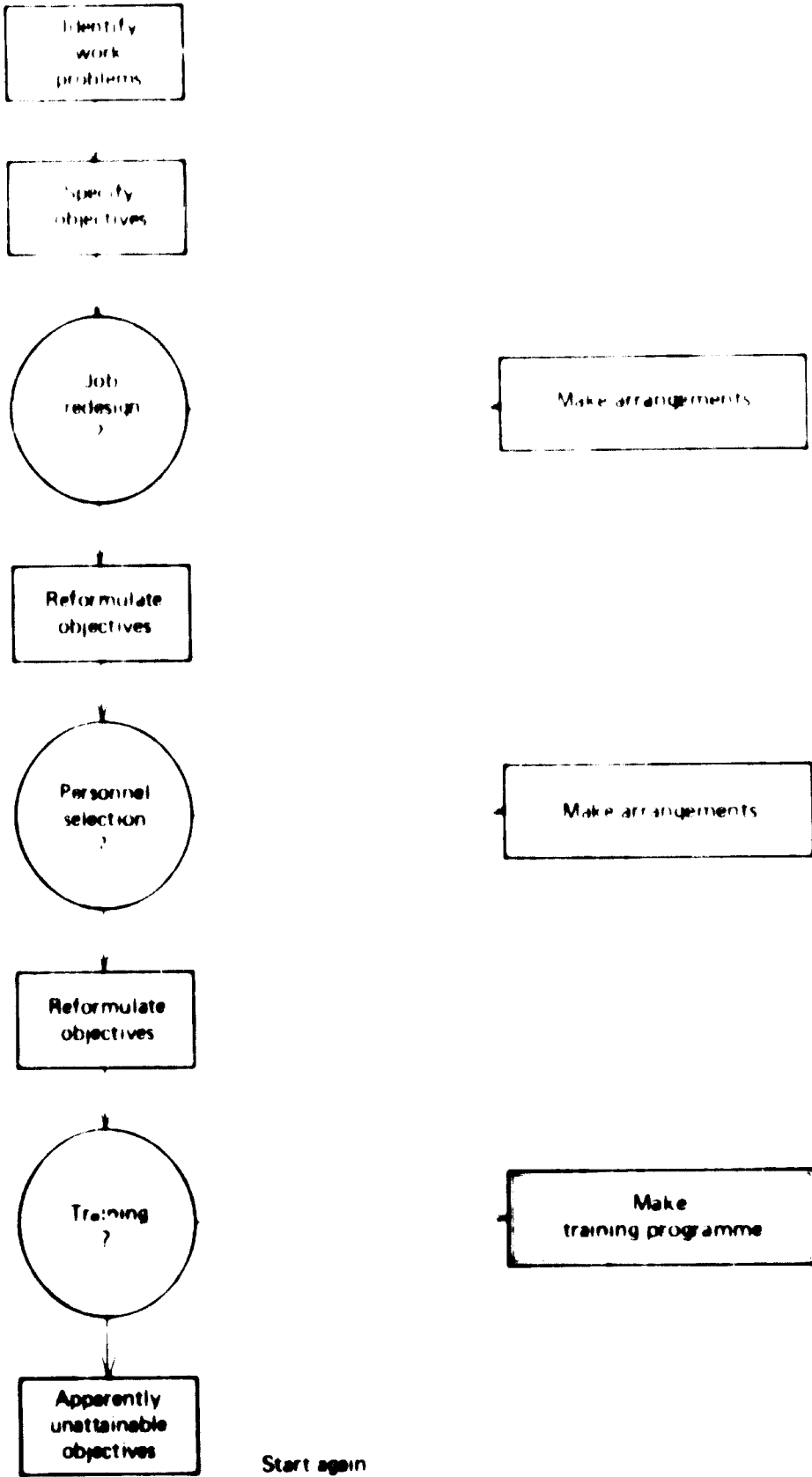

Chart 2

THE SYSTEMS APPROACH TO
MAKING TRAINING PROGRAMMES

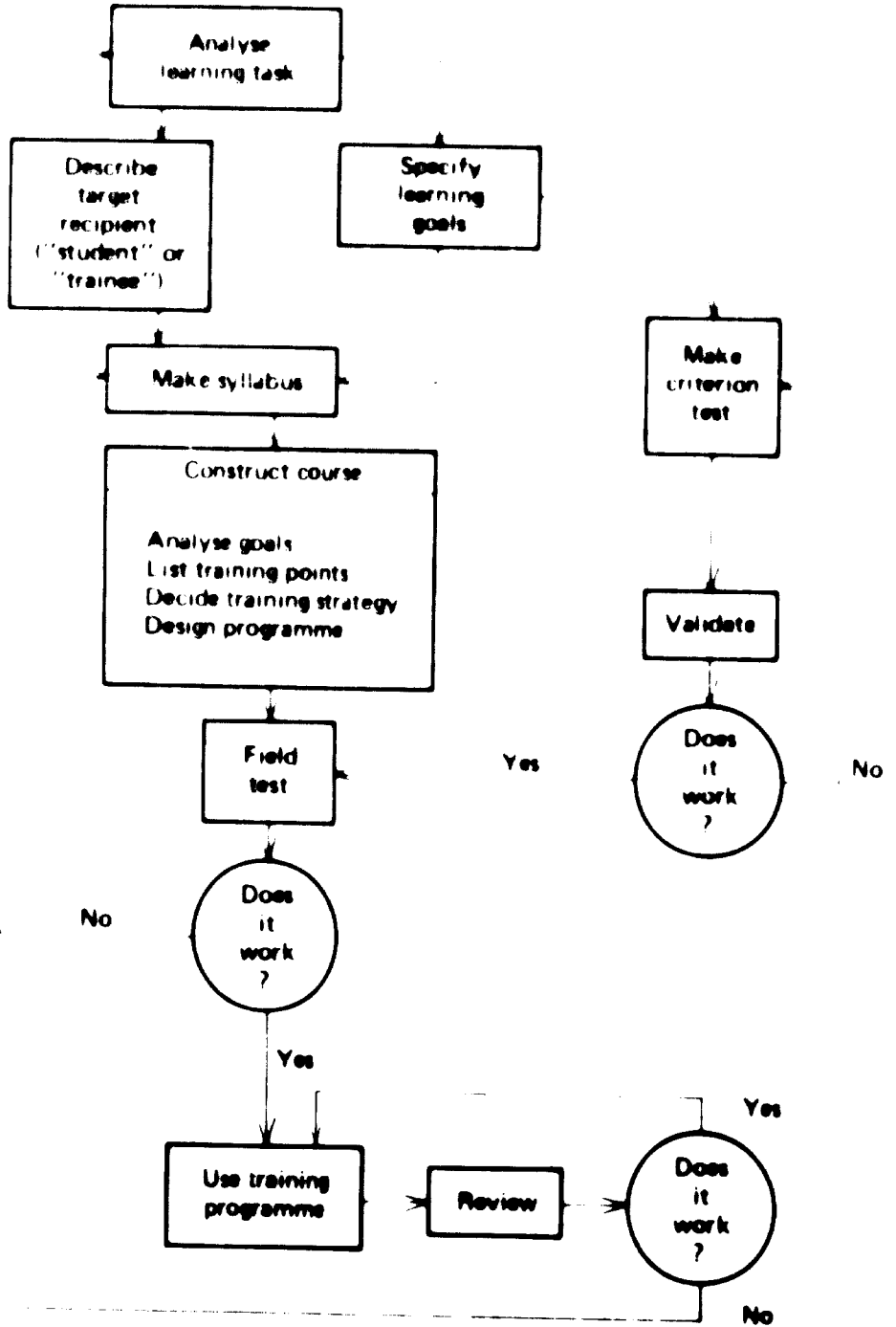
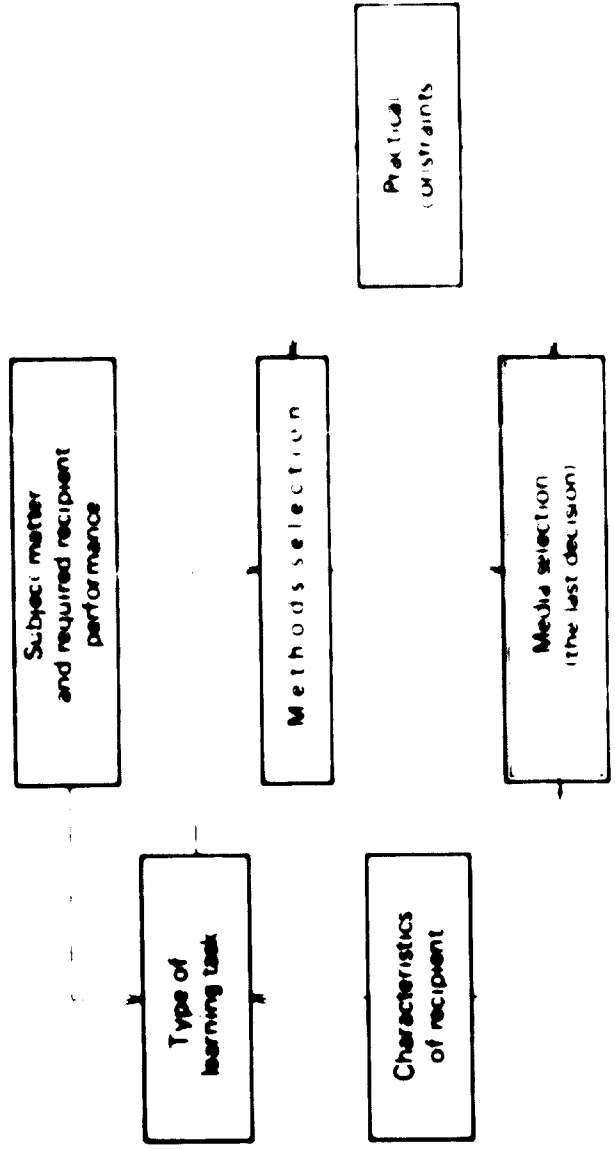

Chart 3

FACTORS INFLUENCING MEDIA SELECTION



Judicious use of audiovisuals is infinite. The most usual problem for the audiovisual trainer is an absurd one, but it's the one that occurs everywhere - from the biggest and most sophisticated corporations to the village classroom. The fact is that nearly all trainers ignore the order of priorities listed in the charts, and select the media before they know what has to be communicated. That is, they choose the tools before they know what the job is. It is an idea that would be ludicrous in most fields, but it happens far too frequently in audiovisuals.

One reason is that people think of mechanical teaching aids as toys. They enjoy playing with projectors, teaching machines, CCTV and all the other sophisticated aids to learning that have been marketed in the last few years. This happens at the highest level of industry. The Senior Training Manager of one of Britain's largest public corporations once had to give a talk on teaching machines to top executives. He made the mistake of displaying the teaching machines while he was talking - and the result was that all his audience ogled the machines and didn't listen to a word of his warnings about them. They all bought the teaching machines - and five years later most of them are lying in cupboards, unused. This meant a waste of many thousands of dollars, which can be attributed to the training manager as much as to the gullible executives.

It is the duty of audiovisual trainers to keep management informed of all the uses and drawbacks of the various new audiovisual tools, and it is his privilege to choose the right tools for the job - but only after he knows what the job is!

The first essential, then, in selecting audiovisuals, is to make sure that your role as audiovisual trainer is clearly understood within the organisation. It is your job, and nobody else's, to select the tools that will best do the work that the organisation needs. Without this basic responsibility, your hands are tied and you can only have a very limited effectiveness.

Once this first problem has been overcome, the charts at the head of this chapter offer good guidelines for actually selecting tools. The particular characteristics of each tool will be described in Part Ivo, and charts 4-7 should be used in relation to the preceding chapter and Part Ivo. Chart 1 expresses an educational technologist's view of the place of training in problem-solving, and should be used as background information. Chart 2 expresses the principles of programmed instruction, also for background orientation. Chart 3 expresses in graphic form the relationship between the factors involved in Media selection. These factors are the subject of this chapter.

(1) PRACTICAL CONSTRAINTS

Some possible constraints are:

- (a) Availability of support materials (chalk, pens, transparencies, film cans);
 - (b) Availability of spare parts (bulbs, fuses, lenses, motors, etc);
 - (c) Availability of software (compatible);
 - (d) Electricity supply;
 - (e) Space available;
 - (f) Light, heat, humidity and ambient sound;
 - (g) Shape and size of room/building;
 - (h) Availability of maintenance, supply and security staff.
- (a) The availability of support materials - materials which are in themselves simple, but which are made and distributed by specialists- will largely depend on the smooth organisation of transport to the audiovisual centre of all necessary materials, and the maintenance of an adequate reserve store on site.
- (b) Spare parts are usually a greater problem. Before you buy a machine, you must make as sure as possible that the spare parts and servicing are available in your part of the world throughout the working life of a machine. Every year, companies make their old models obsolete, small companies close down, and a few

thousand more derelict machines are consigned to the cupboard or the dustbin. There can be no guarantee that the machine you buy will still be serviceable in ten years' time, but there are several ways to make as sure as possible that your machines will continue to work for their expected life-span. The first essential is to maintain a store of spare parts and a technician who can repair most breakdowns. Unfortunately, in the case of sophisticated equipment this can be prohibitively expensive. The best solution in this case is to employ a firm of unbiased Educational Consultants to choose your hardware. If this is too expensive, interrogate the salesman of the hardware companies about the parts and servicing of their machines, trust your own judgement, but always prefer the largest or most established companies.

- (e) The software problem can be as deadly as either of the first two. Its availability is as subject to the problems of these two categories as they themselves are, with the additional factor that if you cannot make your own software for it, a machine without software is as useless as one without a spare bulb or electricity supply.

The other problems are more general, and we will consider them later. But the essential thing is that PRACTICAL CONSTRAINTS are the defining framework within which you can work. If you ignore any of them, you court disaster.

(2) SUBJECT MATTER AND REQUIRED RECIPIENT PERFORMANCE

(3) TYPE OF LEARNING TASK

Once you are fully aware of the practical constraints, the METHODS SELECTION is based on the SUBJECT MATTER AND REQUIRED RECIPIENT PERFORMANCE which will lead to an analysis of the TYPE OF LEARNING TASK (depending on the CHARACTERISTICS OF RECIPIENT). The principles which lead to METHODS SELECTION will be those of Educational Technology, and then the MEDIA SELECTION will be based on the METHODS SELECTION and also the CHARACTERISTICS OF RECIPIENT.

Educational Technology is now a huge field, in which psychologists, educationalists, manufacturers and users (in industry and formal education) are all heavily involved. At the same time it is a very young and unstructured science, which has not yet lead to many practical guidelines. The most valuable concept in learning strategy that Educational Technology has yet produced is the concept of programmed learning - see Chart (2). This is the application of scientific

testing methods to progress in education, and it is becoming more and more relevant to the practical needs of industry as its practitioners become more experienced. However, the ideas of programmed learning are too complex to be dealt with here. They are mentioned firstly to alert audiovisual trainers to their potential importance, but secondly to show that many of audiovisuals' uses in industry cannot easily be operated on this model. Programmed learning can only be effective if there is a precise "SUBJECT MATTER" to be understood or a "RECIPIENT PERFORMANCE" at the end of the day. That is, programmed learning is very relevant to training.

Instruction and Education in the sense of the indication of particular skills and attitudes, but not so appropriate to Displays and Exhibitions, Promotion, Research and Development, or any kind of information dissemination when feedback from Recipients is not analysed. In short, industry needs audiovisuals for advertising, information, entertainment and broadly "educative" communication as well as specifically "educational" programmes in the sense outlined above.

In non-programmed-learning communication situations, the relevance of Chart (3)'s "Type of Learning Task" factor disappears, and the selection of tools for various categories of communication becomes a more

subjective decision. The following suggestions for the selection of tools in these areas are guidelines only.

(1) DISPLAYS AND EXHIBITIONS

These two categories are both ones where the recipient has to be motivated. He is free to stop and watch (and listen), or pass by. Thus the presentation must be strongly attractive, and hold the attention. Visuals must be eye-catching, and recorded sound (if used) must be ear-catching. The designer of the display or exhibition has to spend most of his energy in making the message appealing - and this means that you lose out on detail, but go for a strong appeal to the senses. The presentation has to be slick in a way that a training programme isn't - it's appealing to the recipient as a person rather than as a professional, so it can use techniques that might seem crude or gimmicky in a training situation. At the same time, a successful display is not remembered for its stunning appeal to the senses - its message must be communicated.

Thus the tools to be used for display purposes must be chosen for their capacity to entertain and inform the recipients. A clever gadget that was bought without regard to educational technology may come into its own

in a display. Visuals will be dominant, and the use of words fairly limited. Posters, blown-up photographs, models, automatic slide projection and loop films are all very effective. Hand-outs or free samples can be available to make the recipient "take the message home". In short, tools for displays and exhibitions can be chosen for seductive qualities which are rejected in training programmes.

(2) PROMOTION

Promotion is a category in which displays and exhibitions are a part, but displays and exhibitions can be used within an organisation to keep employees aware of safety requirements, the scope of the organisation, new technological information, administration procedure, etc. "Promotion" refers to all an organisation's publicity to the outside world. However, in large organisations many of its functions are dealt with by external specialists - graphic designers, advertising agencies etc. - and these functions are unlikely to involve the audiovisual resources within the organisation. These are cases in which sophisticated promotion techniques are implemented from within - for instance, the Royal Air Force in

Britain run courses for senior officers on how to act in a television interview - but these are exceptional. On the whole, the audiovisual trainer's role will be restricted to an advisory capacity except in local, specialised or unclassifiable categories of promotion, where local conditions are so important that no general guidelines are possible. However, there are trends in this category which deserve consideration in the selection of tools. The sponsored film in which a company finances the film because its subject-matter is directly or indirectly related to the company's product is one ever-popular promotional device, but it is now less important than it has been in the past. Films date very quickly, and if they are still in circulation a few years after they are made, the old-fashioned construction of the film can create a negative impression. This is less true in animated films than in live action films, but graphics and cartoon styles are also ephemeral. A partial replacement for the sponsored film is the multi-media package for use in schools and colleges. The package can include a film, but more often a filmstrip, booklet and wall charts. It contains information about the originating organisation in educative rather than image-building terms, but can be very

effective in creating awareness and interest.

Multi-media packages are also being used quite extensively by manufacturers to inform dealers and distributors of new products. A kit from British Leyland to announce a new range of cars to their dealers will typically include two filmstrips, a long-playing record, a brochure containing photographs of the car from every angle with a description of relevant sales points, and a Preliminary Service Information Manual. The use of these kinds of audiovisual tools in this context creates a stimulus, provides extensive information, and shows the manufacturer's concern for the dealer's problems.

In general, the criteria for promotional audiovisuals are the same as those for displays and exhibitions. The approach must be bright, sympathetic and modern above all, but the message must shine through clearly.

(3) RESEARCH AND DEVELOPMENT

In this category, audiovisuals are used primarily as recording devices. Glossy presentation is irrelevant, accuracy and detail are all-important. Cameras and

tape recorders can be used to magnify, condense or reproduce images and sounds in time and space (using close-up and long lenses, omni- and uni-directional microphones, fast-running film or tape to create slow motion, time-lapse photography to create fast motion). The use of cameras and tape recorders must be controlled entirely by the researcher, subject to the technical limitations of the equipment which the audiovisuals trainer can provide. The presentation of evidence recorded in this way will depend on the "CHARACTERISTICS OF REQUISITE" (see page 10 and 11) "CONSTRAINTS". It may be that images recorded in motion need projection as still images. The stop-frame device of a film projector may do the job, or the image may have to be re-photographed for permanent access as a print or transparency. It may be that movement does not need to be recorded, in which case a slide-projector will be sufficient, and graphics can indicate the actual movement. For specialised work (slow motion, time-lapse etc), variable-speed motion picture playback may also be necessary. As most projectors run only at 16, 18 or 24 frames per second, it may be better to have a viewer which can provide varying speeds of viewing at the cost of large image size.

Audiovisuals also play a large part in information retrieval for research purposes. Research reports from NASA (The USA National Aeronautical and Space Agency), which apply to many fields outside aeronautics, are only easily available in Microfiche form, and NASA's lead has been followed by other big research organisations. Thus, microfiche and microfilm viewers may be essential equipment for the laboratory's library.

There are many other applications of Audiovisuals in Research and Development. The audiovisual trainer may have to prepare graphics for reports, assist at conferences, and play a large part in the preparation of experiments requiring an audiovisual recorder.

(4) GENERAL

Any ways in which audiovisuals affect people's lives may be of relevance to the audiovisuals trainer. His equipment may be used for entertainment at social events and for general education. He may be concerned with the development of broadcasting (radio or television), in his part of the world. He may liaise with national or international educational organisations, or be involved in local community development. There are thousands of ways in which an audiovisual trainer can serve his industry apart from his Training Programmes,

and his selection of tools will depend on the individual situation. Nevertheless, his main job is training, and all of his expenditure on resources will primarily be for training purposes. Moreover, most of the criteria by which he selects tools for training purposes will apply equally well in other areas. For instance, Plans 1- can apply to Promotional and General purposes as much as for training. In this context, all the remarks in this manual which refer specifically to training can be applied in other fields.

CHARACTERISTICS OF RECIPIENT*

One of the major tenets of programmed instruction is that the content of a training programme is measured by the difference between the **REQUIRED RECIPIENT PERFORMANCE** and the Learning Level of the student before the course. The "CHARACTERISTICS OF RECIPIENT" factor in media. Selection includes his Learning Level both in terms of his knowledge of the subject to be taught and in terms of his communication skills (linguistic skill, literacy, numeracy and "graphicacy"†). The "CHARACTERISTICS" also include the recipient's cultural, ethnic, social and psychological status which are governed by Local Conditions.

†"Graphicacy": visual literacy. The ability to decode information from pictures, e.g. following conventional perspective, "reading" a picture left ↔ right, up ↔ down, understanding visual symbols.

* The "recipient" is the trainee, the student, the pupil or simply a member of the audience.

Part 4

DECISION TREE FOR CHOICE OF MEDIA FOR INSTRUCTION

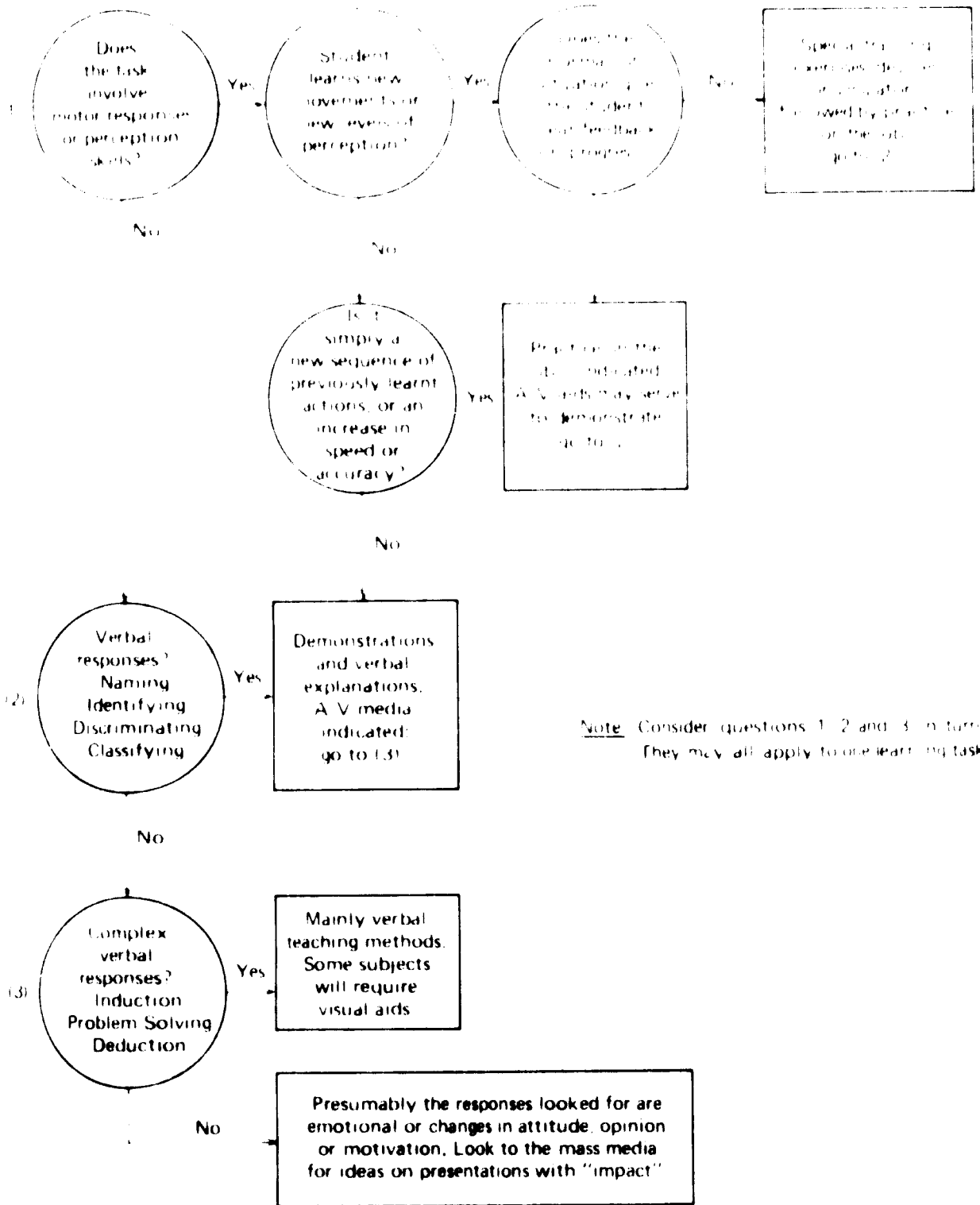

Note Consider questions 1, 2 and 3 in turn. They may all apply to one learning task.

Chart B

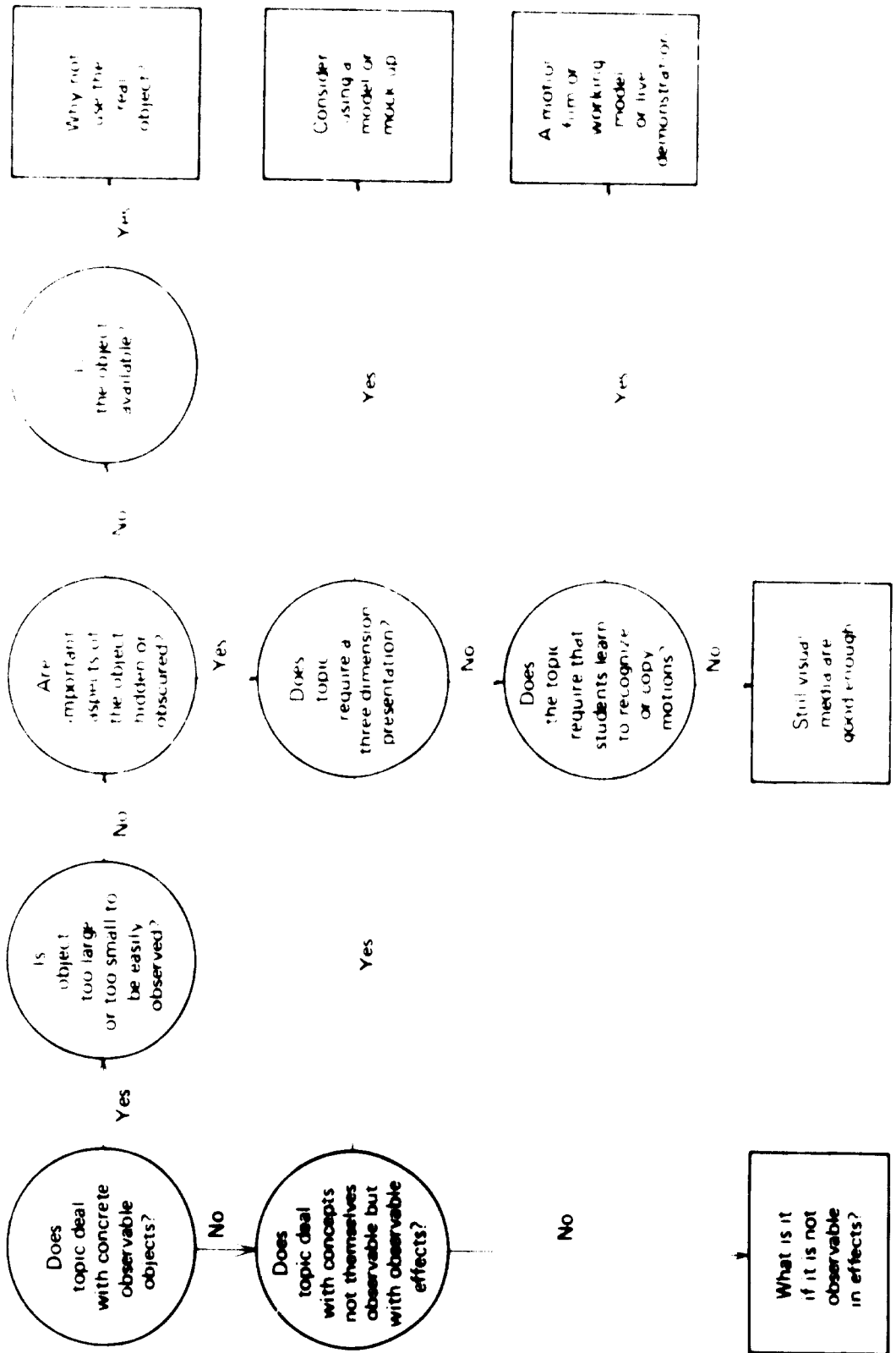

Chart 4.

DECISIONS FOR SELECTING VERBAL AND AUDIO MEDIA

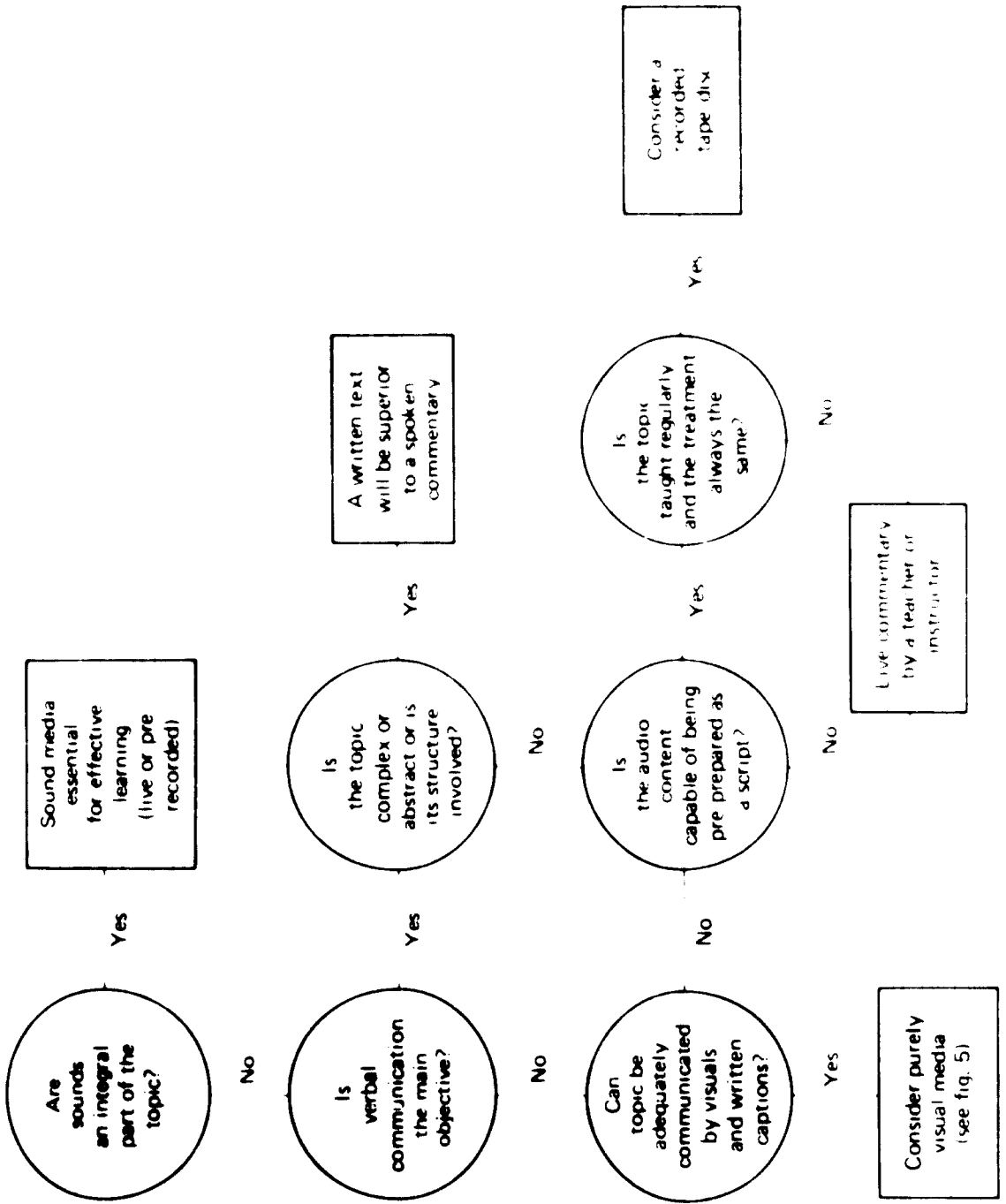

CHART 7

THE "IF-THEN" MATRIX FOR MEDIA SELECTION

The following matrix was designed by Mr. John G. Wilshusen, Jr., of Indiana University, with the assistance of Dr. Richard Stowe,* and is reproduced here with their permission. Since the matrix presents so much information in a limited space, the authors prepared the following explanations of terms used in the matrix. In the matrix, solid shading means "not applicable"; partial shading means "partially applicable"; and empty cells mean "applicable".

LEARNER CHARACTERISTICS

Large, medium, small, individual - refer to sizes of groups of learners.

Visual - Learner characteristics dictate that the stimulus material be visual.

Audible - Learner characteristics dictate that the stimulus material be audible.

Learner Paced - Learner characteristics dictate that the rate of presentation be controlled by the learner.

Response - The medium contains provision for incorporating demand for learner response.

Self-Instructional - Learner characteristics dictate that stimulus materials be so designed that learner is able to use them with little or no supervision.

TASK REQUIREMENTS

Motion - Task requirements indicate that motion must be depicted.

Time (exp/contract) - Refers to the possibility of expanding or contracting length of presentation as compared with real time experience of same phenomena: e.g., slow motion or speeded motion pictures, compressed or expanded speech devices.

*Dr. Stowe is presently director of Instructional Resources at State University College of Arts and Sciences, Plattsburgh, New York, U.S.A.

Fixed Sequence - Refers to characteristic of medium which does not permit change in sequence of presentation beyond forward or reverse.

Flexible Sequence - Medium permits change in order of presentation of stimuli.

Sequential Disclosure - Medium permits revelation of material bit by bit and allows retention of prior bits as further bits are revealed.

Repeatability - Medium allows complete or partial redisplay.

Context Creation - Refers to capability of media to transport learner from awareness of real world to context artificially contrived. Motion pictures are an obvious example, but it is our contention that all media have this capability to some degree. A book has it, for example.

Affective Power - All media have the power to move people emotionally to some degree.

MATERIALS

We feel that items in this group are reasonably clear.

TRANSMISSION

Simplicity - How simple is the equipment to operate?

Availability - How readily available is the equipment required to display the stimulus materials?

Controlability - How much control over the transmission can be exercised by the instructor? (Start/stop, slower/faster, freeze frame, volume change, forward/reverse, repeat, switch to different medium.)

Freedom from Distraction - To what extent does the equipment distract the learners from the intended stimuli?

Darkening not Required - Medium can be presented without necessity of darkening learner environment.

Of course, for practical purposes all these factors have to be measured very roughly, but they are essential in selecting the methods of instruction and, most important, the media. Even though the methods are precisely tailored to the requirements, training time and local conditions, it is meaningless if the media through which the methods are presented fail to speak in the recipient's language. This is true of diagrams and pictures as well as words. If you add to the language difficulties the problems which arise from suddenly confronting someone who has little experience of technology with an industrial environment, it may be impossible to teach anything at all.

The selection of media has to take into account the advantages of using particular media against the disadvantages of having to translate their unfamiliar language. In all cases, the instructor has to direct the curiosity of his students towards relevant subjects.

It is possible in an extreme case, that some of the trainees have never seen an instrument or machine like the one they are being trained to operate. The whole business may lie beyond their experience and comprehension. In such a situation the tutor must be aware of his audience's retention level which depends on his evaluation of their intelligence, maturity, and experience.

It is essential to construct a presentation in such a way that it can be integrated within the learner's general understanding. It should also be realized that no matter what advantages technology holds, the introduction of new equipment, products and processes is often not related to environmental features.

Students from an agrarian background have to work much harder to understand technology than students who have lived with it all their lives. It is important to relate a presentation to a given environment.

The material presented should be conceived so that it is closely related to the environment in which it is used. Strong illumination, strong contrast of light and darkness as opposed to soft shades and shadows, would be in keeping with the environmental conditions in tropical countries. Good visibility and simplicity helps clarity and perception. The main features being presented must stand out clearly from the background, the field of view must be well placed, allowing for sustained concentration without interference. The audience must be given plenty of time to look and absorb the material, especially if it is unfamiliar.

If verbal and written elements are used in association with the presentation material, comprehension and memorisation will be affected and, here again, clarity and relevance must be taken into consideration. The audience's verbal comprehension and reading capacity must be evaluated. If not, interest is lost, attention is distracted, and the learner is prevented from grasping the subject.

Learners must feel familiar with their learning programme and a photographic presentation with precise and accurate description can help them. However, for detailed and specific information, for instance in the case of explaining complex equipment, simplified or stylised drawings or animated diagrams can provide a clearer definition.

Much educational material depends on the use of symbols and codes. These may bear little relation to any environmental situation with which an audience is familiar. The introduction of signs such as directional arrows, lines and symbols to represent time and space, or elements like force and wind, need familiarisation. Once grasped, such information can be understood and assimilated without any specific training. On the other hand, there are a number of specific dangers in

the understanding of even the simplest pictorial material. Simple signs representing distance, converging perspective lines and the superimpositions of objects in perspective can be incomprehensible if not explained beforehand.

On the whole, locally produced material, which takes full account of environmental aspects and the level of intelligence of the learner, is preferable to material brought in from the outside. This applies mainly to software because in most cases the hardware can only be obtained from appointed dealers.

Printed brochures, leaflets and books can no longer be considered as the most efficient means of conveying technological changes, particularly in territories where reading and writing is not the instinctive and traditional habit. It is also unlikely that instruction which relies on the printed word can be at all effective without some form of audiovisual help where visual communication has already been established, in television and cinema, as a part of everyday life.

In spite of the available range of audiovisual aids which can, if wisely chosen, suit practically every

occasion, there are still too many learning programmes which are too abstract, academic, confusing and dull. The proper use of audiovisual aids can make a presentation vivid, interesting, concrete, and from both the trainer's and the learner's point of view, more effective.

As was explained in the first chapter, the use of audiovisual techniques does not depend on the purchasing of expensive equipment. An expert user of simple aids can be a vital asset to any organisation. It may often be better to spend money on training more trainers than to invest a large capital outlay on hardware, although it will take longer to train trainers up to the required standard with simple aids than it will be to learn how to use a film projector, and it is often the case that trainers of the right calibre are just not available; whereas equipment that reduces the burden for one man can make him many times more efficient. Unfortunately, the expenses of maintaining equipment, obtaining software and constructing any sort of Media Resources Centre are hidden costs which may well exceed the cost of such measures as the importation of trainers from another country at inflated salaries.

Although it can be a great stimulus to learner-oriented education, the rapid development of modern technology

can be more of a hindrance than a help. If electricity is in itself a problem, it is likely that the support systems necessary to maintain complicated hardware will be impossible. If the cultural level of the recipients is radically different from that of developed countries, it is likely that most software imported from developed countries will be useless or even harmful. An Audio-visual instructor is not a man with a machine - he is a man who is trained to present information audiovisually - and whether he uses chalk and talk, or CCTV, he has to have expertise in audiovisual communication.

In the right hands, a chalkboard can be more valuable than any other aid. A mixture of voice, writing, drawing and erasing can provide audiovisual information, moving pictures - and efficient learning. The chalkboard is cheap, durable, and can be used anywhere. No software is needed. All you need is a trainer who can use the chalkboard to its full advantage - and these people are very rare.

Nevertheless, simple aids are the first essential on any trainer's shopping list. A bad teacher may be only 10% efficient, but a broken-down film projector is 0%.

The argument for simple aids does not rest on the idea that the messages transmitted by simple aids are easier to understand than the messages transmitted by elaborate aids. In fact, it is much easier for an uneducated person to understand that he must copy the people he sees in motion pictures than it is to understand the combination of words, numbers and pictures that he sees on a blackboard. Because the most sophisticated aids can bring the messages which are closest to real life, they can easily be used with illiterate people.

The technology of using sophisticated aids (as opposed to that of making and maintaining them), is much simpler than the technology of using simple aids (and compensating for their lack of reality). Ten year old children can easily learn to operate a CCTV camera and VTR - and they can show a videotape of themselves performing a task far more easily than they can explain verbally what they did. The Maharishi who taught the Beatles how to meditate is now sending videotapes of his meditation techniques to his disciples ... and he completely renounces technological society!

The characteristics of recipients are the most complex factors affecting the choice of tools. A student may

be distracted by a machine, but relate well to the pictures and sounds it emits. He may understand a chalkboard, but be confused by what is drawn on it.

EVALUATION OF COST-EFFECTIVENESS

When a trainer is only using simple aids and home-made disposable software, cost-effectiveness of the training programme can be computed in terms of the value to the organisation of workers after training as against the cost in manpower and facilities of operating the training programme.

When more elaborate media are being considered, the evaluation of cost-effectiveness is a much more complex procedure. There is not yet any widely-accepted methodology of media evaluation.

There are a large number of variable costs involved in media selection on a long-term basis, but it is usually the case that elaborate media justify a high initial cost by a substantial long-term return on investment. If you use a chalkboard, you have to do the same amount of work every time you present information with it.

If you use more extensive equipment, you can usually use the same software again and again, which substantially reduces many labour costs as well as having other advantages.

The relative costs of equivalent media in any situation will depend on the amount and type of instructional content that needs to be produced, and how often that content is to be presented or repeated. Production, presentation and repetition are key factors, and should each be computed separately but considered in conjunction.

The variables involved in computing media selection have now been expressed in simple mathematical terms by M.J. Oatey, whose report "Effectiveness and Costs of Instructional Media" is available from the Air Transport and Travel Industry Training Board in the United Kingdom. A companion volume is available as a programmed text for use by trainers in real or imagined case studies.

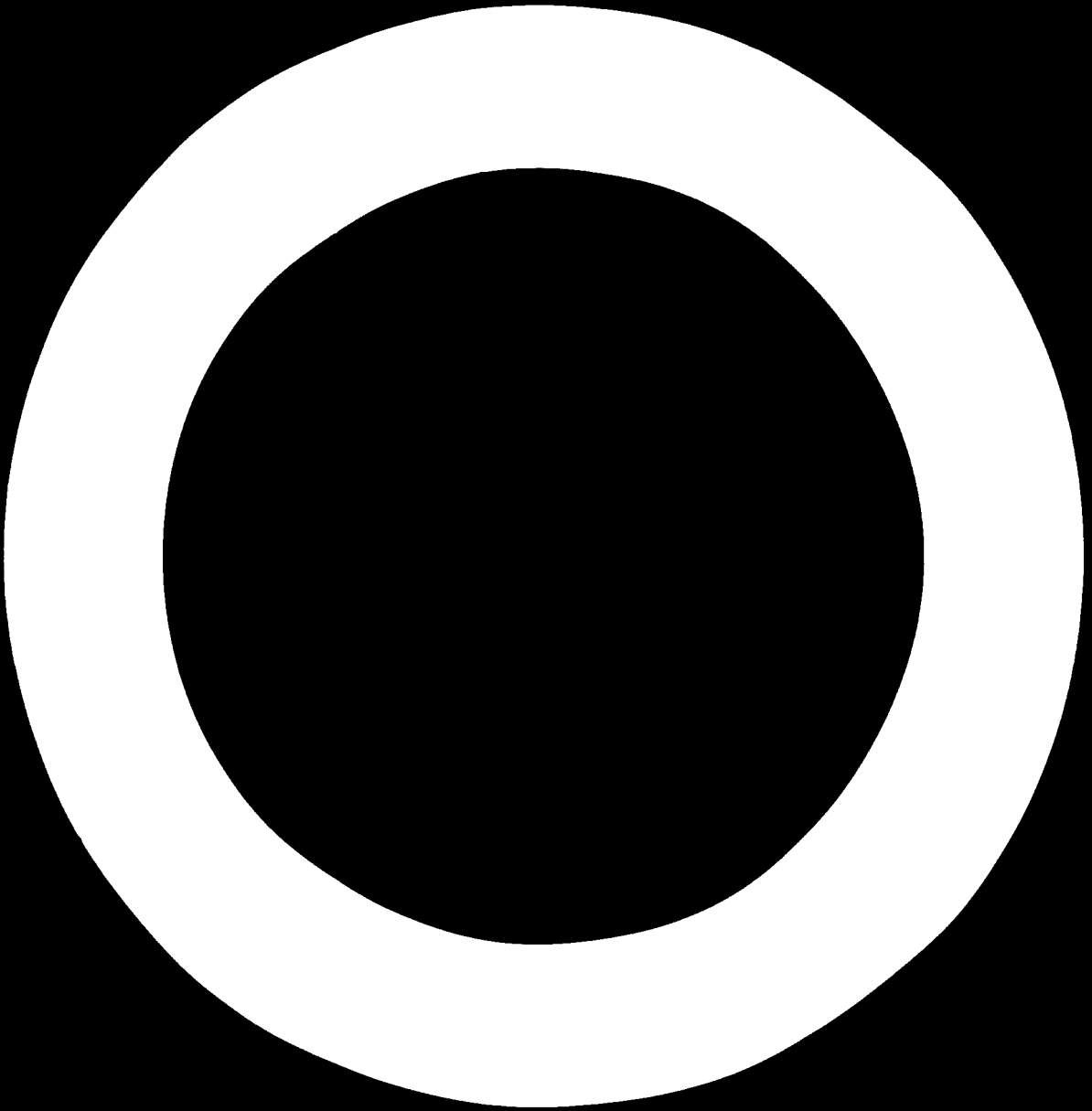

and the right time.

2

INSTRUCTIONAL MEDIA

PALETTE

1953-54

Utilization of Instructional Media will involve
as far as they mainly concern themselves with acquiring
and maintaining the right sort of skill which is vital
for the right sort of job. All this preparatory work
is absolutely essential, but the test of your
selection of media is in their application on the
shop floor, in the classroom or in the lecture hall.
This is where your theories are put to the proof,
where you can check your evaluation of all your
background information, and where you are actually
communicating to the trainee.

Here, the most important thing to remember is that
communication consists of three separate, but
entirely interdependent parts, which can be called -

Message

Channel

Recipient

The message is the information you want to give.

The channel comprises all the media and methods used
to get it across - whether your voice in a classroom,
or the projection of a film which has been exposed,
processed, printed, edited and dubbed with sound.

The Recipient receives the Message through the Channel -
and any deficiencies in Message or Channel will be

reflected in his imperfect subsequent performance. You may think you have a clear message and a perfect channel, but if you have not got through to the recipient, the message is not really clear and the channel is not really perfect. The only remedies in an actual learning situation are the traditional ones of every teacher - self-confidence, adaptability, sensitivity to the learner's problems, and the skill to surmount them in any way that is available. If this means abandoning a tape-slide programme for a chalkboard, it doesn't matter. The basis on which you set up the programme must have been incorrect, but in the meantime you must get on with the job as best you can.

We expect that in the vast majority of situations there will be no need to change a carefully prepared programme at the last minute. But it is the quality of the preparation that matters, and not the amount you do. There is no point in preparing a learning programme, a room, equipment and software if the end result is no improvement in learner performance. And the more sophisticated your tools are, the more preparation they need; and the disaster of an unsuccessful demonstration is all the greater.

Bearing in mind the necessity for abandoning prepared programmes in an emergency, the rest of this chapter will be devoted to the practical ways in which the channels of communication can be as perfect as possible on the shop floor. In this context, the size and shape of the room, the light level, the heat, the ambient sound and the time of the day will all play a part in making the channels effective or not.

Physical Facilities

In the past it took a trainer thirty to forty-five minutes to prepare a room and set up his equipment. Today it can be simpler and quicker - in the case of the projector with built in screen as one unit, there is no need to darken the room. Strong projection lights through better designed lenses also help to make a clearer defined projected picture, so even front projection can be used in a semi-dark room and there is still enough light to see the students.

If projection takes place in the open air, special arrangements must be made. If there is a lot of light interference, shielding of the screen is essential; the projector does not need shielding from the light.

Availability of power² is another factor. If there is no electric power, the portable battery will be used as well. After all, motor cars use long life batteries which, if properly maintained, provide energy for several months or even years. Whatever energy is consumed, however, must be replaced, and while a car can recharge its battery during running, the same does not apply to the projector. Consequently after ten hours' use, or approximately twenty short periods of projection, it is wise to have the battery recharged. It is also essential to ensure that the power supply driving the projector's motor should be at a constant speed in order to avoid light flicker, and, if sound is used, frequency fluctuation. These can occur if the battery is allowed to run dry.

Under any conditions, the audiovisual operator must check the voltage required to drive the equipment, and the length of the power cords and cables. He must make sure that the correct plug is fitted in advance of the presentation, and that there are some extra projection lamps available. In extreme heat it is especially important to protect not only the equipment but also the films inside or outside their cans as heat does make them curl up. If the equipment is left

² See "Using projectors away from mains electricity" by G. Gordon Hewlett in Educational Development International: Vol 1 Number 2, July 1973

outside in the open air it must be protected from heat and damp which can damage it.

When the lecture takes place in a building, the size of the room should be related to the number attending the lecture, and the acoustics taken into consideration. If the room is overcrowded the physical discomfort impedes the lecturer and does not promote efficient learning. Very large rooms with a small audience can handicap the acoustics and concentration. Ideally the environment for an audiovisual presentation should be especially constructed by an expert who can ensure that the power supply is correct, arrange the platform and desks for the students to take notes, and design the layout of the room to encourage a direct personal contact between lecturer and students. Such a room can, if necessary, hold a maximum of fifty learners although thirty is more functional.

The room should not be smaller than ten metres by fifteen metres, and its height not less than three metres. Air circulation should be regulated and the acoustics good. For instance, concrete walls and floors are not good sound carriers, so sound-insulating hardboard and a felt or carpeted floor is preferable. Safety is another factor - doors must be easily opened, and there must be easy access to them.

These are the minimum physical requirements for a place which is to be used for film shows or meetings. For frequent audiovisual demonstrations it is so much more convenient to have a place permanently equipped with the right facilities.

Application and follow up

The purposeful application of audiovisual aids depends not only on good intention, willingness or interest in a new technology, but a degree of professionaliss (i.e. knowing how to handle the equipment and how to integrate it in a learning situation). In developed countries extensive sources are available for teachers and future audiovisual operators to acquire these skills, but unfortunately these facilities are not available universally. However, what is unavailable on the technical and theoretical level need not be a handicap on a practical level. With common sense, careful choice of media, and a will to experiment, any good trainer can apply audiovisuale imaginatively and intelligently. The scope of application is extremely wide in every form of audiovisual communication, whether the objective is information, training or teaching of a skill, and there are no hard rules for procedure.

It would be useful to restate some specific guidelines once again: first - a specific knowledge of the group; second - the necessity of selecting the most suitable type of aid; third - careful preplanning of the presentation.

It is also useful to restate that a step by step presentation is better than conveying too much information too rapidly. Clear visual material is always essential. The opportunity to practice with the actual equipment or tool is a great advantage if they are at hand - physical handling in learning a skill combined with gaining an understanding of the theory is more effective than either of them separately.

A simple guide for using audiovisuals can go as follows:

- 1) for day to day information and announcements use the display board or any other non-projected technique;
- 2) for information requiring permanent memory retention use projected images;
- 3) preview all audiovisual software and make notes;
- 4) the audiovisual aids should be only a part in a series of lessons making up a study unit;
- 5) train another person to assist operating the equipment

- 6) audiovisual aids should be used as teaching tools and not as time fillers;
- 7) make a clear definition of when and where the audiovisual aid is to be used.
- 8) follow-up is an important aspect in any situation and should be considered an integral part of the programme. This should vary according to the purpose for which the trainer has used his audiovisual aids.
- 9) keep looking for better ways to use audiovisuals.

The main drawback to the last item is that most trainers are too busy implementing their methods to communicate them to trainers in other organisations.

Eventually, perhaps, there may be a system for information-exchange between training establishments, preferably at frequent intervals. Unfortunately the difficulties in this are theoretical as well as practical. The criteria for establishing the relevance of one organisation's audiovisual training methods to another organisation are argued over by educational technologists throughout the world. Only when there is a measure of agreement amongst theorists can practical experience be properly evaluated and communicated to interested parties.

Designing Facilities

In spite of the commercially available instant lettering, signs and shapes for magnet and flannel boards, it is almost certain that a demonstration will require the presenter to produce some designs in front of the class. The production of such visuals will have to be synchronised with the verbal presentation by the lecturer himself. When the two elements work together well, the presentation has a good chance of success. The production of visual graphics by the teacher is a vital element in the preparation of a demonstration.

It is important to refer to some elementary factors in design and graphics in the context of audiovisual presentation.

Design means the creation of order out of chaos. It is the assembly of various visual elements into a graphic arrangement which will put across the main points of the demonstration to the learner directly and clearly.

The graphic arrangement should be fixed through the layout - the elements which have to be put into a

harmonious whole are words, lines, colours, planes, space and texture. The tools to be used can be pencils, crayons, pens, inks, charcoal, brushes of all sizes.

The layout is the co-ordinating factor which determines the basic format and composition of an image, and this should be prepared beforehand. Improvisation in front of the class can hold up the lecture and can lead to a confusing mixture of drawings.

The proportion of lettering and writing should always be well balanced with other visual elements in a composition and related to each other; only a layout can determine such relationships. In the meantime, the size of the visual elements can be defined - words must be clear and readable even from the furthest point of a class; drawings should be reduced to their simplest elements. If a drawing needs complex visual effects, such as shading and texture, these should be prepared prior to the lecture so as not to interfere with the flow of the presentation.

The characteristic behaviour of various writing tools should also be studied. For instance some pens which are good for fine work may be difficult to wipe off.

Instead coloured wax pencils can be more suitable, depending of course on the type of surface being used. The felt-tipped board-writers provide bold clear lines if this is the effect required.

A smooth visual presentation requires careful study of design techniques. The first step is not to choose too difficult an approach. It is valuable to produce some rough sketches in the simplest line drawings and bring up the images step by step in the context of the content and continuity of the lecture. The drawings or any element of visuals should not be considered on their own artistic merit, but should be an integral part of the whole presentation.

Although the display industry has concentrated on making the presentation of visuals, including graphics and lettering functional and easy for the lecturer, the instant presentation in front of the class still holds a magical effect and can be very effective and valuable.

The lecturer does not need to be a skilful designer or artist himself, and yet, with a little background study in design, he can communicate his programme with the maximum effect.

Backup to a learning programme

We have already mentioned a large number of essential preparations before embarking on an audiovisual learning programme, but not to the administrative organisation which can successfully undertake these preparations. In a large number of cases, the audiovisual trainer may be the only member of the audiovisual section of his organisation, and perhaps the only member in the training section, too. He has a lonely, specialist job, which inevitably involves more work than his colleagues would believe possible.

These are some of the functions he must fill:

- (1) Close contact with company policy, particularly training policy.
- (2) Keeping up to date with information on new equipment, software, and industrial training practices.
- (3) Evaluating training needs, characteristics of the subject and practical constraints, then planning training programmes (unless there is a training officer).
- (4) Selecting media for training programmes.
- (5) Evaluating, buying, maintaining, servicing and storing equipment.
- (6) Buying or preparing, designing and making software.
- (7) Careful costing and planning ahead.

- (8) Creating a media development plan.
- (9) Training a colleague to take over in emergencies.
- (10) Implementing programmes.
- (11) Evaluating results, planning new programmes.
- (12) Keeping colleagues informed at all stages.

There are a number of ways in which this burden can be eased, even within the resources of a small organisation. First of all, there may be assistance available from Governmental and International industrial development agencies. This may take the form of money, specialist advice, or even a ready-made training programme for particular needs.

Secondly, existing staff can be used to handle some of the work. If there is a draughtsman, or a chart writer, he can make visual software. The electrician can also be responsible for maintaining electric equipment, and carpenters or metal workers can make and repair other equipment.

Thirdly, trainees can operate audiovisual aids within the duration of the training programme, and assist in preparing rooms etc.

Fourthly, maintain the interest of colleagues and superiors. Most people have some interest in audiovisuals, if only by association with entertainment cinema, and will often provide support when it is needed.

Below is a chart of the possible organisation of a small audiovisual department. Film and television units are less essential than photographer and illustrator; illustrator is more important than photographer; maintenance and storeman can be more important than an illustrator.

.

TABLE 5

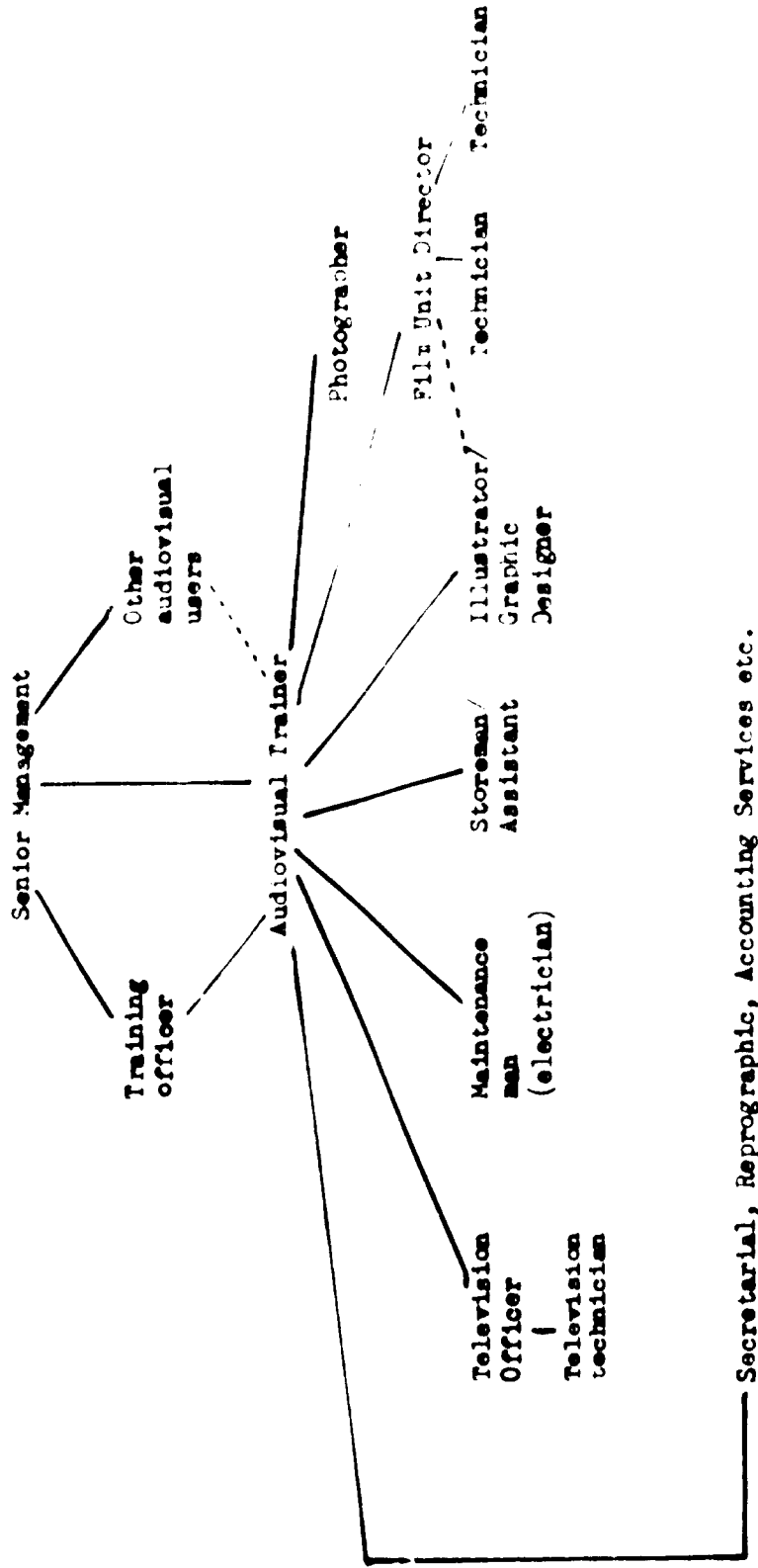

Secretarial, Reprographic, Accounting Services etc.

The physical shape of the audiovisual department will vary widely from place to place. It is essential that it should be as far as possible a self-contained unit, in which the audiovisual trainer has immediate access to staff, tools and trainees. At the same time it must be seen to be an integral part of the organisation, and preferably not situated in an obscure corner which nobody can find. The four most important functions of the department are production, presentation, maintenance and storage. Each should have its own room or rooms, although certain kinds of combinations can work well.

For instance, the tools used by trainee fitters, electricians, mechanics, etc. to practice on the "real thing" can be stored in the maintenance area and used for the upkeep of projectors and other equipment: but stationery and software must be kept somewhere else.

AUDIO VISUAL TECHNIQUES

FOR INDUSTRY

PART TWO

TECHNIQUES AND TOOLS

CHAPTER ONE

NON-PROJECTED AIDS

The Chalkboard

The chalkboard consists of a painted wooden plate all with a white or colour chalk to write on the surface of it. It can be supported by fixing the board on to the wall if the lecture hall is interior or placing it on an easel if the lecture is to take place in the open.

Advantages:

It can serve a variety of objectives -

- (a) it needs no elaborate preparation and setups such as a darkened room or electrical equipment. It can also be used in the open air.
- (b) it is comparatively inexpensive.
- (c) it is long-lasting and upkeep is easy.
- (d) the demonstrator can use it instantly.
- (e) it allows a chance for the apprentice to actively participate in the demonstration.
- (f) mistakes can be easily corrected.
- (g) the demonstrator is able to adapt his material to the skill and intelligence of his audience.

Disadvantages:

- (a) the chalkboard doesn't provide movement like film.
- (b) the diagram drawn on the board needs careful preparation as part of the lecture.
- (c) it is confined to the writing and drawing skill of the lecturer.

1. Treat the board as if it were a piece of paper. Write on it and keep it clean.

Hints for preparing a lecture

It is necessary to prepare the lecture notes beforehand and mark up the sections which should be demonstrated visually on the board with as much clarity as possible. The guideline for what can be shown on the board visually and what can be put across verbally should depend on the content of the subject, the intelligence of the audience, and your skill.

In some cases it is advantageous to draw on the board a statement or diagram before a demonstration starts. Then with the text and the material which has been previously prepared, a statement can be built up step by step carefully controlling the timing and the pace of presentation according to the learner's capacity.

The learning environment must also be considered.

It is effective to involve the learner in the process of the lecture. An active response can be achieved for instance if some of the words or symbols are drawn by the learners themselves before or during the lecture.

Self instruction could be most effective in the learning processes once the learner is sufficiently motivated to study by himself even if the learner may not be technically perfect.

A degree of proficiency in craftsmanship is essential even in the handling of a chalkboard. It is an asset

to be able to draw and write on the board efficiently and in synchronised rhythm with the spoken words. This is the ideal and can be one of the quickest and the most efficient tools to put across the instructions.

A few hints -

- (a) do not turn your back on your audience when speaking while you write or draw on the board;
- (b) be quick with your visuals;
- (c) make the pictures clearly visible to everyone in the audience;
- (d) make the words clear and legible (this may mean rehearsing beforehand);
- (e) use thick, clear and bold lines;
- (f) always have a cloth available to erase for corrections;
- (g) always have extra chalk ready.

The Markerboard

Unlike the blackboard the surface of the markerboard is white. For this reason it is often called "THE WHITEBOARD". Its development was made possible by the introduction of felt tip pens during the last years. It is especially useful where cleanliness is required. The board is usually made of white plastic on which the images are applied with felt tip colour markers. Multicolour writing and drawings on white surface could be of some importance in laboratories and in situations where it is useful to reproduce symbols in colour codes and where dustless atmosphere is required.

Advantages:

- (a) no dust by chalk
- (b) can be maintained to be the clearest of all boards
- (c) several colours can be applied
- (d) the board can serve as a projection screen
- (e) can be the basis of strong graphic images
- (f) mistakes can be easily wiped out
- (g) it can be used in the open air

Disadvantages:

- (a) the markerboard doesn't provide motion like film
- (b) the drawings and writings require careful preparation
- (c) reflection can be a problem with strong sunlight, but with slightly white surfaces this problem has been overcome
- (d) damp cloth is required to wipe off corrections. it is necessary to wait till the board is dry before proceeding again. this may take slightly longer than chalk
- (e) the colour markers must be the right sort; water based, if they are spirit based they easily leave unwanted marks on the board. If this occurs the

marks must be washed off with a domestic bleach or special liquid removers manufactured by the markerboard suppliers.

Hints for preparing a lecture

Just like with other boards it is essential that proper preparation should be made before the use of the markerboard. Since the use of bright colours are possible the advantages of this factor should be utilised. If the lecturer has the skill and the craftsmanship it is effective to write and draw from notes instantaneously in front of the class as the writing tool provides an effective way of emphasising and clarifying certain points in a demonstration by multi-colour writing and drawing.

Since the visuals appear more defined on the white, than on blackboard, the layout should be more carefully considered. The appearance of the visuals is clearer and more professional looking; because of this it is preferred by both the lecturer and the pupils.

The teaching however must be adjusted from the use of chalk. Instead of holding it upwards the felt tip marker should be held downwards similar to normal writing. The colour ink flows from the pen with far less resistance on the smooth plastic surface than chalk against wood surface.

A few hints:

- (a) do not turn your back to your audience while writing and drawing.
- (b) work out the exact time when using the markers.
- (c) it is valuable to have some points already drawn on the board at the start of the lecture.
- (d) work out the layout of the visuals beforehand and make sure that both writing and drawing are clearly visible even from the back of the class.
- (e) make functional use of colours, but do not use colours for their own sake.
- (f) always have a cleaner kit available to erase and to correct.

It is an advantage to be able to draw and prepare such graphic pictures as symbols, diagrams, images and lettering.

The Flipboard

The flipboard consists of 10-20 large sheets of drawing paper attached by means of screws or clips to a stable backing. The sheets are drawn or written on with spirit markers, crayons etc. during the course of a lecture or demonstration, or, alternatively pre-prepared sheets may be mounted in the required order of exposition. When no longer required, each sheet may be folded (or "flipped") back over the board to reveal the next sheet, calendar fashion.

Flip boards and easels are commercially available, but can also be constructed simply to one's own specifications.

Advantages

- (a) just-free in use
- (b) time saving when a lecture is required to be repeated several times
- (c) relatively cheap and easily transportable
- (d) flexibility - professionally finished diagrams and/or one's own drawings can be shown
- (e) concentration of audience is focussed only on the diagram being shown at the moment, not on preceding material.
- (f) points made during a lecture can be quickly and easily reviewed in order to sum up its content.

Disadvantages

- (a) practical considerations of size limit the applications of the flipboard to small conference or class-rooms
- (b) it is normally necessary to turn one's back on the audience when writing
- (c) spirit markers will often seep through to underlying sheets unless paper with a non-porous coating is used
- (d) open air use is not advised.

Hints for Preparing a Lecture

Make your letter and drawings as large and bold as possible - writing should be at least 1" high. Do not overfill each sheet. By lightly penciling in the material you intend to draw in advance of your lecture, you will not only have an excellent "aide memoire", invisible to your audience, but your lecture will gain in fluency and assurance. Avoid using paper with a very shiny surface, since this will cause distracting reflections.

The Flannelboard

When two pieces of rough-textured cloth are placed together, they tend to adhere. This principle has been used in the flannelboard; a rough material is stretched over a hard backing, and other pieces of material cut to a desired shape are placed upon it to form a diagram. These pieces of material can be written or drawn upon at will. It will be found that, providing the underlay is rough enough, not only other pieces of cloth but also paper and similar light materials will adhere almost equally well.

Advantages:

- (a) The base cloth can be removed and rolled up, so that together with the diagram elements it is easily transported from place to place

(b) cheapness.

(c) Given imagination and the wide variety of cloths available, the graphic effects to be achieved through this medium are almost unlimited.

(d) The same elements can be used repeatedly.

(e) The lecturer does not need to turn his back on his audience in order to place new elements on the board.

Disadvantages:

(a) Suitable for small audiences only, since symbols etc. placed on board are difficult to make out at distances much in excess of 15 feet.

(b) The weight of larger elements can sometimes cause them to slip; to counteract this tendency, the board can be inclined backwards a few degrees from the vertical.

Hints on the Preparation of a Lecture

At a maximum viewing distance of 15 feet, symbols or letters should not be smaller than 1 inch. The adhesive elements should wherever possible be in colours offering maximum contrast to the board itself. Special papers are available in various colours which are specially designed to adhere to flannel-boards; should one wish to employ printed paper matter which does not adhere

to the board easily, special paper may be glued to the back of it (sandpaper will also work). It is a good idea to make an index folder containing the different elements of a lecture in the order in which they will be required and to attach the back of each element accordingly - for the sake of order, a point should be made of replacing each element removed from the board back in its folder - an arduous task after a lecture - sometimes very difficult to sort out!

The Magnetboard.

The magnetboard is a board of some ferrous material to which small magnets are glued to the backs of the elements to be displayed. One should distinguish here between magnet boards and the less well-known magnetic boards; the latter are themselves magnetic, and as a consequence will retain small ferrous metal objects placed on them.

Advantages:

- (a) **The magnetboard is an ideal form of display in any planning or design context where frequent changes during the planning process are necessary, e.g., interior decoration, circuit diagrams, seating arrangements at conferences or banquets.**

- (b) Subject to the strength of the magnets used, even three dimensional objects can be stuck to the board (e.g. small model vehicles for driving tuition).
- (c) The board may be painted to provide any permanent background required.
- (d) The backgrounds may be varied by placing paper sheets over the board on which the new background has been drawn; providing the paper is not too thick the magnetic elements will continue to adhere to the board. (See "Flip Boards").
- (e) If the magnetboard is painted matt black it can serve as a combined blackboard/magnetboard.
- (f) Providing not too many sheets of paper are used flipcharts can be used in combination with the magnetboard to increase its versatility.

Disadvantages:

- (a) Magnetboards and their associated materials are heavy, bulky and difficult to transport.
- (b) When moving the magnetic elements, care must be taken not to scratch the surface of the board.

Hints in Preparing a Lecture

Check in advance that any elements you have prepared do, in fact, adhere to the board- if they are too heavy, counteract this by attaching additional magnets. This is particularly important if you intend to use several

layers of paper over the board. When not in use magnets should be left adhering to the board so that they do not lose their magnetism - the board acts as a "keeper". Many modern conference rooms have steel strips underneath the plaster of the walls; these are specially designed for magnetboard applications. Magnetboards are ideally suited for the production of titles and other pieces of text for slides and films.

The Plastigraph

This is similar in application to the Flannel-board, except that it operates on the principle that two smooth surfaces adhere to each other. Sheets of clear celluloid are mounted on a smooth board made of glass, enamel or some other metal by means of pins at the top of the board. Onto these sheets are placed the display elements, which are cut out of coloured plastic foil. A complicated display can be built up element by element so that, thanks to the transparent sheets, the end effect is that of one complete diagram.

Advantages

- (a) By comparison with the Flannelgraph, the Plastigraph allows a diagram or similar display to be built up in progressive stages
- (b) The brilliant colours in which the plastic foil is available make a plastigraph display

easier to see and more eye-catching. When a transparent base is used, this brilliance can be increased by back lighting.

- (c) Adhesion is greater, so the board may be used in draughty situations or outdoors.
- (d) The cut-out elements are tough enough to withstand repeated use and can be moved about at will.
- (e) The various plastic surfaces can be written on with washable markers during a lecture and later erased. If a metal base is used, magnetic elements can be incorporated in the display.

Disadvantages:

- (a) Unsuitable lighting can cause unwanted reflections on the board.
- (b) Plastic foil is considerably more expensive than paper.
- (c) The foil's great adhesion sometimes makes the removal of elements difficult.
- (d) Dust can interfere with the adhesive properties of the plastic and is difficult to avoid because of the material's tendency to become charged with static electricity.
- (e) Displays which are left too long will curl at the edges, particularly in a warm atmosphere.

Hints for Preparing a Lecture

As with a flannelboard, the prepared sheets and elements should be kept flat in a folder in the order in which they are to be presented. If difficulty is encountered in removing elements, a small piece of paper may be glued to the underside edge to afford purchase for the fingers. If static causes trouble, anti-static aerosols are available.

The Multiboard

As its name might imply, the multiboard combines characteristics of other display boards in one unit. It is, in fact, a flipboard, chalkboard, magnetboard and screen for projected aids all rolled into one, and more modern equipment can even be used as a plastigraph board.

Advantages:

- (a) See under the headings for the individual types of board. Otherwise the flexibility permitted by this type of board is an obvious advantage.
- (b) Most boards are collapsible and easily transported.
- (c) Ideally suited for conference rooms and customer demonstrations.

Disadvantages:

- (a) See under the headings for the individual types of board.
- (b) The boards multiplicity of functions can be

- confusing to those unfamiliar with one or more of its functions.
- (c) Some commercially available boards are too heavy for ease of transport.
 - (d) The over-enthusiastic user of such boards sometimes falls into the error of over-exploiting its potential during one lecture, thereby confusing his audience.
 - (e) Some combination board manufacturers reduce the size of the display area in order to save on weight. This limits the applications of such boards to small auditoria.

Practical Tips

See under headings for individual board types.

ALTERNATIVE VISUAL TECHNIQUES
FOR INDUSTRY

PART TWO
TECHNIQUES AND TOOLS

CHAPTER TWO
VOICE PRODUCTION

Audio

In this chapter, we shall be dealing with sound alone, divorced as far as this is possible from any consideration of visual aids. It should be remembered, however, that many of the remarks made about the applications of equipment for sound reproduction apply equally well to audio-visual equipment; this will perhaps be better understood if it is borne in mind that a sound projector is essentially a film projector into which the equivalent of a tape recorder has been built, and that neither a tape recorder nor a sound projector can give of their best in competition with a pneumatic drill being operated in the near vicinity!

Sound

Before dealing with the practical aspects of the subject it would be as well to have some elementary knowledge of the nature of sound itself - what it is, and how it is propagated. For our purposes, sound can be most simply defined as air-borne vibrations which make their presence known to us through our ears, i.e., our sense of hearing. The physicist would also include vibrations beyond or below the audible range, but since we are concerned with sound as a means of human communication, we need not bother with them unless we are seriously thinking of setting up a seminar for bats.

Any object vibrating at a frequency within the human range of hearing will normally impart its vibrations to the air, and the air will vibrate in sympathy with it. The sound waves thus produced will set up vibrations in the human ear, which then converts them into electrical impulses which are carried to the brain.

The human vocal chords operate on entirely mechanical principles, similar to those of musical wind instruments: air from the lungs is forced past the vocal chords, and depending on the degree to which these are extended or contracted, sounds of varying pitch and loudness issue from the mouth. These sounds are capable of being modulated further through the action of ancillary vocal organs in the mouth- the tongue, palate and lips- to produce the complicated series of sounds known as speech. It is perhaps because we are so familiar with it that this, the human means of communication par excellence, is so often neglected, and for this reason, no apologies are offered for including the human voice here as a piece of audio equipment having prime place in the field of instruction.

Voice Production

In any instructional situation, the lecturer or instructor must endeavour to be

- (a) Audible
- (b) Intelligible
- (c) Interesting

A professional actor or lecturer has learned how to project his voice in such a way that, without the benefit of an amplifier, he can be heard distinctly even by large audiences. He has realised the simple fact that the volume of sound he produces is directly in proportion to the amount of breath - or energy - he applies to his vocal apparatus. The ability to do this should not be confused with knowing how shout; in shouting, the loudness of the voice is certainly increased, but the energy comes from the lungs only; the modifications to the speech organs necessary to maintain conversational intelligibility under the stress of a vastly increased flow of air through them is ignored. Good voice production at increased volume, on the other hand, depends on the speaker still being capable of exerting full control over his speech organs under these (for the average person) exceptional conditions. Leaving aside the content of what you say, the technique of good public speaking is, like so many other things, acquired simply by an awareness of the problems involved and by constant practice. Having said that, the following simple tips will be of help:

- (a) Since your breath is the main source of energy for what you say, it follows that you will need more of it in public speaking than in normal conversation: hence, take a really

deep breath whenever possible, and try to time your breathing in such a way that an intake of breath coincides with a natural pause in what you are saying. Practise breathing in and out in a quiet controlled fashion; few things appear sillier than a speaker gasping for breath at the end of a monstrously long sentence for which he has taken insufficient breath, so breathe deeply or use shorter sentences! If you are preparing your own lecture or instructional material, remember that language written for the eye to read, does not necessarily sound good to the ear. Short, pithy statements in simple language are preferable to long involved sentences which may look good on paper but can sound pompous and artificial to the ear.

(b) Direct your voice as far towards the back of your audience as you can. In practice, this simply means keeping your head at a somewhat higher angle than might normally be the case. At the same time, however, take care that you appear to be addressing your audience as a whole- you do not need to keep your eyes on the last row of listener as well! A common error is for the lecturer, without realising it, to suddenly become mesmerised by a member of the audience who gives the appearance

of being particularly interested in what you have to say, and to address the whole of your lecture to him. This may be prompted by nervousness or lack of experience, but will normally be construed as bad manners.

- (c) Inexperienced speakers in front of strange audiences often exhibit unusual mannerisms which distract the audience from the subject matter of the lecture; swaying to and fro, spectacle polishing and other so-called displacement activities are to be avoided as far as possible.
- (d) Avoid speaking too quickly, particularly if your audience consists of people who are not native speakers of your language. This might at first sight appear to be a superfluous warning, but experience shows that a nervous speaker often races through his lecture, possibly in the hope that by doing so, he will draw the audience's attention away from any inadequacies in his theme or presentation of it; the reverse is true.

AUDIO VISUAL TECHNIQUES
FOR INDUSTRY

PART TWO
TECHNIQUES AND TOOLS

CHAPTER THREE
PROJECTED STILL PICTURES

Projection Equipment

There are many different types of projection equipment which will enable the user to display small graphical materials of all kinds on a large screen, so that a group of people can see the original graphics, greatly enlarged by optical projection onto the screen. The screen size may be selected to suit the size of the room and the number of people viewing. The distance of the projection equipment from the screen will determine the size of the projected image. Normally the projection equipment is sited behind the viewers, throwing the projected image onto a screen at the front of the viewers. This is known as Front-Projection and pictures shown in this manner must always be presented in a properly darkened room. When circumstances do not permit a darkened room, special Daylight Projection screens may be used. Such screens have a high reflectivity which allows for projection even in a room in full daylight. However, such screens are usually highly directional so that a bright image will be seen only by viewers in the centre of the room, whilst those seated off-centre towards the edges of the room will see an image greatly reduced in brilliance. Thus, in certain situations where the viewers can be seated at the optimum viewing angle, usually a small group, Daylight screens may be effective. However, such screens are very much more expensive than normal projection screens. A further alternative may be a Rear-projection system in which the projection equipment is housed in a box, the image being projected onto a translucent screen via a mirror angled at 45° to the projection lens. There are a number of

commercially manufactured rear-projection systems available but ^{it} must be noted that these systems always employ a small screen size around 1' x 2" and thus are more suitable for individual or at best two or three people to view. Therefore, it is recommended that a properly darkened room be provided.

Darkening A Room

When converting a room by covering the windows with such materials as heavy drapes, opaque blinds or hardboard so as to exclude daylight, it is essential to ensure that there is adequate ventilation for the audience - otherwise there is a danger that viewers will become sleepy due to a stuffy atmosphere and not able to absorb the information being presented to them. This is particularly so in hot climates.

FRONT-PROJECTION SYSTEMS

Projection of graphic material is achieved by optical means and each projection system has been designed for a specific purpose. The choice of equipment will depend on the ^{type} of graphic material to be presented. This can range from a simple hand drawing on paper or a page from a book or magazine, through transparencies, colour slides (with or without sound accompaniment), filmstrips to the more sophisticated motion-picture presentations.

An important factor governing the choice of projection equipment (known as 'hardware') and the selection of the graphic medium (known as 'software') will be the availability of back-up facilities such as art-work and photographic equipment and skills. The question of available funds for any particular project must be a decisive factor. The user must determine the cost-effectiveness of a chosen system by relating it to his specific needs as well as his local resources.

Power Supply.

Hardware of all kinds for projection requires an electric power supply to operate the light source as well as cooling fans and projection motor. Even the simplest equipment needs current to power the projection lamp. It is important, when ordering equipment, to ensure that it will operate on the local mains supply. The local supply should first be checked - whether A/C or D/C. For example, most projection equipment using electric motors operates on A/C current only. The local voltage should be known as well as the frequency, in the case of A/C current. This will normally be either 50 Hz or 60 Hz, depending on the part of the world. Most projection hardware to be discussed in this chapter will have a variable voltage control for the input and some equipment will also have a facility to operate on 50 or 60 Hz. Should there be any doubts about the local supply voltage and frequency, the local power supply company should be consulted. When ordering equipment, voltage, frequency

must be specified. In areas where there is no power supply only, special care will be needed, since there will be problems with equipment operating on A/C power. It is possible by consultation with local electrical engineers to arrange for a power converter which will convert a D/C supply into the required A/C voltage and frequency, in cases where the required hardware is available only in A/C power.

When it is necessary to operate equipment in the field, i.e. in areas where there is no mains power supply, it is possible to obtain a converter which can be driven from a heavy-duty car battery. Such a converter will then produce the current to power the equipment. Here again, the power requirements of the hardware must be specified when ordering a converter.

STILL PROJECTION HARDWARE.

The Epidiascope.

This is a very simple, yet highly flexible and effective projection device. It is relatively inexpensive and easy to use. The Epidiascope consists of a metal housing which contains a powerful projection lamp, a mirror and a projection lens. The mirror is placed at 45° to the optical axis of the lens and is arranged so that any kind of graphic material placed underneath the housing, in the space provided, will be illuminated by the light source. The illuminated graphic is reflected by the mirror into the projection lens which throws the picture onto the screen. The plan drawing illustrates the layout. (Figure 1)

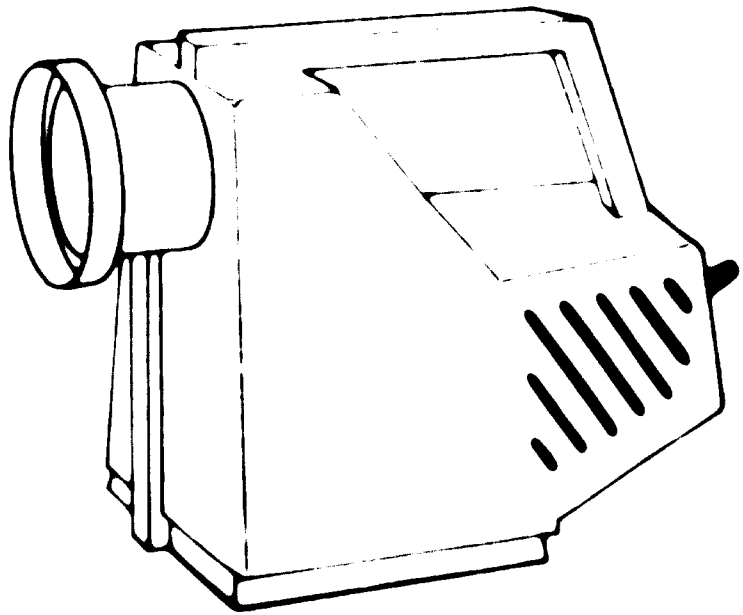

The size of the projected image on the screen is determined by the distance of the Epidiascope from the screen and the focal length of the projection lens. A wide range of graphic material may be presented with this equipment, simple hand drawings on paper, pages from a book or magazine, photographs and even fairly flat objects such as a pair of scissors or a printed circuit board. Using a little imagination, even movement can be screened. For example, magnetism could be demonstrated by placing iron filings on a piece of white paper under which a small magnet is inserted during projection. A large image of this demonstration will be thrown on the screen and the filings will be seen moving into their polar positions.

The Epidiascope is, therefore, a simple but very effective projection tool. The cost is not high and there is little to go wrong. The only service needed will be attention to cleanliness of the mirror and lens. These are best cleaned by brushing gently with a soft camel-hair brush or lightly dusting with a piece of soft linen. Ensure that there is an adequate supply of spare projection lamps and that one of these is always available during a show or lecture.

The Overhead Projector.

This is one of the most popular projection devices for use in the class or lecture room. It consists of a light-box housing a powerful projection lamp, which is aimed at a translucent area covering the top of the box forming a flat illuminated table. Usually, there is a Fresnel lens beneath the table which ensures



76.07.01

2 OF 2
06184

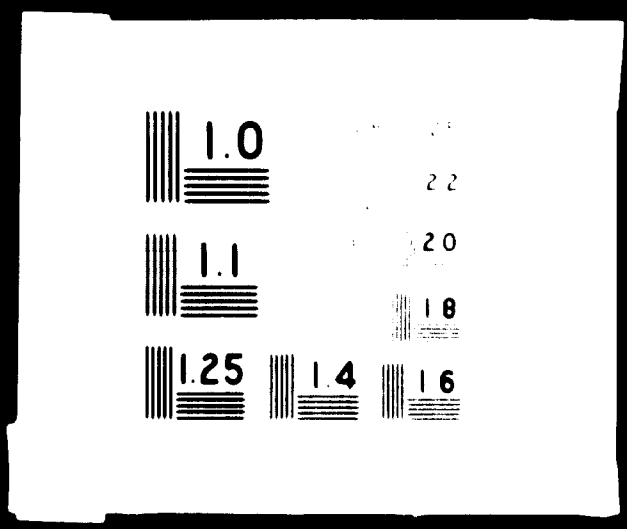

even distribution of the projection lamp over the working surface. An upright column is fitted to the side of the light-box which carries a projection lens and a mirror set at 45° to the optical axis of the lens and the working surface of the light-box. The whole of this assembly can be adjusted vertically so that the distance from the lens unit from the light-box platform can be varied. (Figure 2). Some makes of Overhead Projector have a fully rotatable lens head, thus allowing the user to face the equipment in whichever direction is most convenient. Further useful refinements to this device consist of a heat filter between the light source and the working platform, a cooling fan which is thermostatically controlled and roll holders fitted to each side of the light-box to carry a roll of transparent material across the top of the light-box. All these refinements are desirable and it is as well to ensure that any make of machine being considered includes these features. In use, any transparency, either previously prepared, commercially published or drawn on a blank section of the transparent roll during the lecture, may be projected onto the screen, with a large, bright image. The average size of the illuminated platform forming the working area is about 10" X 10". The teacher has a wide variety of options which he may employ when using this equipment to present visual material. Facts, figures, drawing and diagrams may be hand drawn on the

Figure 2

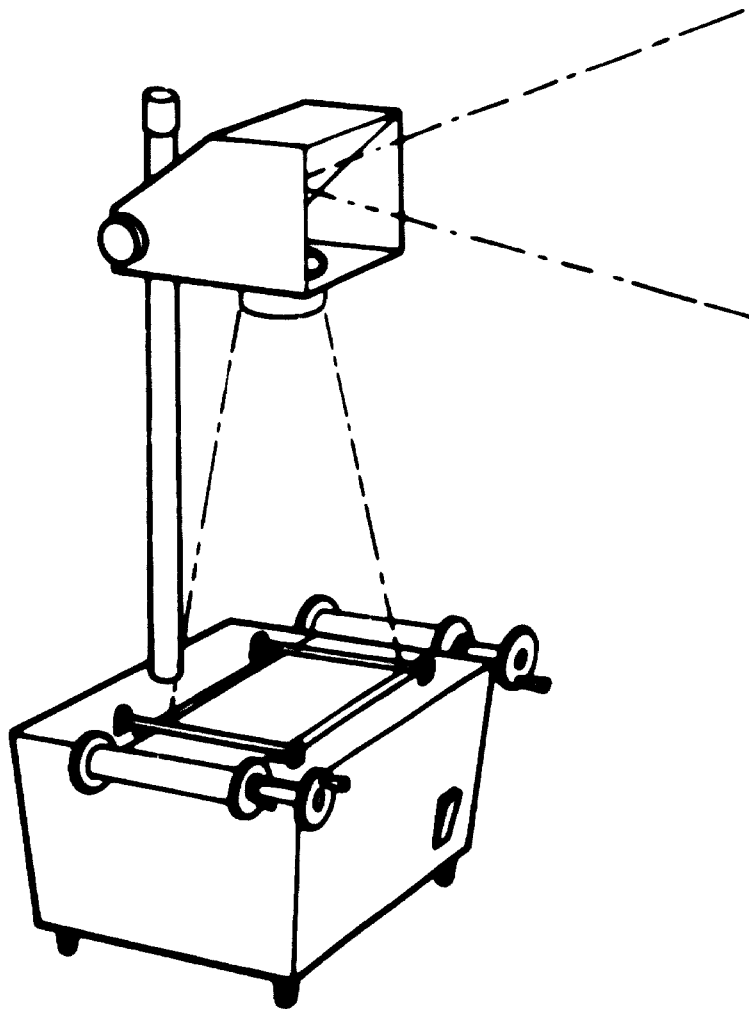

clear transparent film during the lecture. Virtually, the system becomes a sophisticated chalk-board, since the user can draw or write his information, using if required, different coloured pencils. The viewers see the visual as it is being drawn as they listen to the lecturer. Making use of the roll-holders which carry a roll of transparent film material enables the user to bring a fresh drawing area over the light-box very easily. It also allows him to refer back to previous information by winding back.

The Overhead Projector is now firmly established as an indispensable training aid in the industrialised countries and is used widely in education and industry. Many large international industrial organisations have had special programmes produced for use in Overhead Projectors. Such programmes consist of a specially prepared book, containing a full set of transparencies printed in multi-colours bound together with the lecture notes in such a way that the appropriate notes appear opposite the transparency being used. These books are printed in quantity, in different languages and in this way, a standard of information and training is possible. The programme books are spiral bound, thus allowing each transparency to be laid flat on the projection table. One main automobile company uses this method for service training throughout Europe and the United States of America.

Slide Projectors.

Historically, the Slide Projector was probably the earliest picture projection device. In the nineteenth century, it was known as the 'Magic Lantern'. This consisted of a large metal box housing a strong light source such as gas or acetylene which faced a simple condenser lens at the front of the box. This lens concentrated the light onto a square aperture, in front of which was a wooden slide carrier which carried two glass slides, the carrier being arranged so that it could be pulled to and fro horizontally across the illuminated aperture. A projection lens was mounted in front of the slide carrier and thus threw a large image of the slide onto a screen. Whilst one slide was being shown, the next slide in a series could be inserted into the other space in the carrier and by pulling the carrier across, the next slide would be projected. By inserting new slides into each side of the carrier as it was moved from left to right, and removing the previously projected slide, a continuous presentation could be made of any length and with any number of slides. No doubt the name 'slide' derived from this process of sliding the picture carrier to and fro during what in those days was called a 'Lantern Lecture'. Either the lecturer operated the slide projector himself, whilst delivering his lecture, or an assistant would operate the projector, feeding the slides in, the order of them having been arranged before the lecture.

The lecturer would then be able to deliver his lecture at a position near the screen at the front of the audience and signal to his assistant to change slides by snapping his fingers or using a small castanet. In these early days, the slides were large in area, at least 3½" X 3½" and pictures or diagrams were hand-drawn on the glass surface. Different colours were used for greater effect. Then, as the art and technique of photography developed, it became possible to print photographic negatives onto specially prepared glass slides carrying a photographic emulsion and thus project a large positive picture in black and white. Today, with the progress of photographic techniques and skills, slide projectors have become much more sophisticated. Nevertheless, they employ the first principles of the early machines. (Figure 3)

Since the advent of 35/mm cameras for still photography together with modern colour films, the majority of slide projectors are now in the 35/mm format. The simplest and least expensive kind of projector is a modern miniature version of the old 'Magic Lantern'. It consists of a lamp housing containing a high power projection lamp, a condenser lens, slide carrier and projection lens. The whole being very compact, highly portable and not expensive. The only electrical part is the projection lamp and this can be ordered

Figure 3

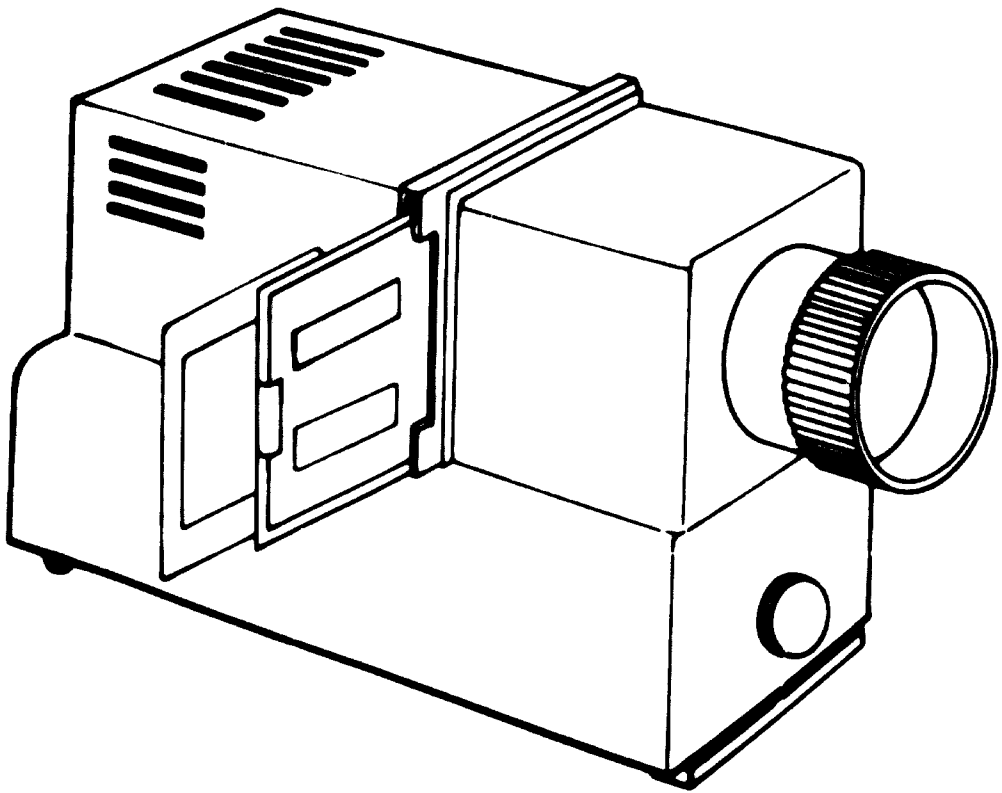

either in mains or battery supply. Some simple 35/mm slide projectors have low-voltage projection lamps and have a built-in transformer to reduce the mains current to the required voltage for the lamp. Often, the lamp voltage is 12 volts, which means the equipment can be operated from either mains or from a car battery. Slides for 35/mm slide projectors are the same size in picture area as the standard 35/mm still camera, i.e. 24 X 36/mm. The basic 35/mm slide projector can be a very effective visual tool for the presentation of pictures which can be taken on a modern 35/mm camera. Today, these cameras have become very easy to use because they have automatic exposure systems built into them and for a modest sum such a camera can be purchased. Then, by using reversal-type colour films, the user is able to photograph the scenes needed to cover a subject in pictures. The exposed film is then sent to the nearest processing station and the pictures are returned, mounted in card slide mounts, ready for projection. Naturally, the resultant pictures will depend entirely on the skill and imagination of the photographer. This method for making pictorial slides in colour is suggested as basic technique for producing pictures on any given subject and presenting them on the basic slide projector described.

There is much to commend this simple slide production and presentation method in areas where there are no sophisticated photographic and art-work facilities. Although the method is simple and requires only a 35/mm still camera and compact slide projector, just as with any teaching or information programme, it is necessary for the person making and presenting the programme to prepare the content carefully. A logical sequence of pictures to be taken to cover the subject should be worked out on paper, together with the text to accompany each picture. Thought should be given to the value of close-up pictures related to a wide view picture, because these close-up details will add impact and clarity to the programme. Where funds permit, it is well worth providing for a more expensive 35/mm camera of the single-lens reflex type because this will enable the user to photograph large close-up detail with great accuracy. Such cameras can usually be supplied with a series of close-up diopter lenses which can be fitted to the front of the camera lens. This will allow for the photography of very small objects in extreme close-up. This facility will prove of great value, especially in industrial training. It will also enable slides to be made of existing charts or drawings and the copying onto slides of any other graphic material.

When all the material has been photographed, it will be returned from the processing station and they will have cut each frame of film and mounted them on card slide mounts. These card mounts are suitable for short-term use and should a more permanent storage method be needed then it will be necessary to instruct the laboratory processing the film not to mount the frames of finished colour reversal film and to return them unmounted. Special 35/mm glass slide containers can be obtained from the projector suppliers and the individual frames mounted in these holders. This method prevents any damage to the film and is recommended for permanent storage.

There is only one correct way of inserting a slide into the slide carrier on the projector. Because of the optical system in the projector, the picture image is inverted through the lens. For this reason, slides must be put into the slide carrier upside-down. There is also only one correct position for the slide insofar as the surface of the slide will be in relation to the light source. This is determined by the type of material the slide was originated in. The 35/mm film frame on which the slide was photographed will have an emulsion side which is identified by its matte surface, the other side being the film material which can be identified because it is shiny. In cases of material produced on colour reversal film, the film base or shiny side must face the light source and the

emulsion side should face the projection lens. A useful method for ensuring that slides are always loaded into the projector properly, is to fix a small piece of adhesive paper to the top right-hand corner of the slide mount when it is in its proper position for projection. The slide number can always be written on this small paper area and it serves the purpose of indexing a series of slides as well as ensuring that they always appear on the screen properly. For simple hand-drawn information, there is available a special blank opaque slide with a surface on which information can be drawn or written. These slides will be useful for uncomplicated graphic information, bearing in mind that the area available to be written or drawn on is confined to 24 X 36/mm. These special slides are known as 'Ektagraph' slides and are available from the Eastman Kodak Company.

So far, the simple slide projector and methods for making pictorial slides for it have been discussed. However, there are a number of more sophisticated slide projectors with built-in electro-mechanical features which allow for automatic projection of slides. They are all based on the same principles as a simple slide machine but have added facilities. There are projectors which accept plastic slide magazines holding up to 50 slides. These magazines are simply a plastic box with a series of grooves in it into which the slides are loaded. Thus, a complete programme may be loaded correctly and stored ready

for projection. The slide magazine in this type of automatic projector is oblong in shape and fits into a channel built into the side of the projector. The least expensive type of magazine slide projector is simply hand-operated. When the magazine is in position, with the first slide aligned opposite the projector aperture, a metal carrier is pushed in and this carries with it the first slide. When the carrier is withdrawn, the first slide is replaced in its slot in the magazine, then when the carrier is moved forward again, a ratchet mechanism moves the magazine up to align the next slide in the series and in this way, the whole magazine can be shown.

A further sophistication of this principle employs an electro-mechanical drive to operate the slide mechanism. A remote-control cable is plugged into the projector with a push-button on the end. The lecturer may then change slides in the magazine as far as 30 feet from the projector, at his own pace, to suit the lecture. A further refinement is to extend the electro-mechanics of the projector in such a way that momentary pressure on the control button advances the next slide, whilst a longer pressure causes the magazine to move backwards, thus allowing for retrieval of a previously shown slide. This is a useful function when the lecturer wishes to refer back for emphasis.

Another additional refinement is the provision of an automatic timer which can be set at different times so that each slide is projected automatically and the duration of time it is held on the screen is determined by the variable timer control. The main use for this facility is in exhibitions; it is not essential for use in training. The most sophisticated automatic slide projectors have, in addition to the remote slide-change button, another control built into the machine and remotely controlled by the cable, allowing the focus of the projector to be adjusted. Some machines even have a small optical unit built into the control unit at the end of the remote-control cable which allows the lecturer to project a small white image of an arrow which can be superimposed on the projected picture so as to point out specific details in the picture. Where a larger quantity of slides are required to be presented and stored in a magazine, there are circular wheel-type magazines which sit in the magazine channel of the projector and can hold up to 100 slides. The magazine rotates at each slide change being driven by the same ratchet principle. There is also a machine designed to take circular slide trays fitted horizontally on to the machine. These trays take up to 80 slides but the machine will only accept this type of magazine and was designed specifically as an audio-visual tool. In all other respects it has the same remote-control and automatic features as the flat oblong magazine type

of machine. There is a particular advantage so far as slide containers are concerned. With the plastic magazine box or circular plastic magazine driven by a ratchet, it is necessary to remove the magazine cover securing the slides for transportation, before the magazine can be inserted. When the magazine cover is removed, there is always the danger of accidentally tipping the magazine over during handling. When this happens, the slides fall out and much time can be wasted before a show, re-inserting them in the proper order. With the machine employing the circular tray which fits flat and horizontally into the machine, the slides, once loaded are kept in place permanently by a sleeve with a central flange which is fitted into the centre of the magazine. This type of automatic slide projector is manufactured only by the Kodak Company and is called the "Carousel". Summarizing the automatic projectors, there are numbers of different manufacturers producing the type of machine accepting the plastic box type magazine and some of these also accept the larger capacity circular wheel-type magazine. These machines are manufactured both in the U.S.A. and Western Europe as well as Japan. The nearest local photographic or audio-visual dealer should be consulted if this type of machine is required. The Carousel machine is usually distributed by audio-visual dealers, otherwise the nearest Kodak or Eastman Kodak office should be consulted.

Setting up a Slide Presentation

Whichever slide projector is finally chosen, it is necessary to make proper preparation for a slide lecture. Ideally, a permanent lecture room in which all the audio-visual equipment is located, ready for use, is desirable. This may not always be possible particularly when the equipment is taken out to a location or used in the field. In any event there are a number of essential needs to ensure smooth and efficient presentation:-

1. A firm table or stand for the projector. This must be of sufficient height to clear the heads of the viewing audience. Failing this, if a lower table is to be used, then the viewers' seats must be so arranged that heads do not obstruct the beam from projector to screen. Make a check after siting the projector on its table at the back of the room, by arranging the chairs and sitting in seats near the centre of the room with the projector throwing an image onto the screen.
2. The projected picture size will depend upon the distance of the projector from the screen and the focal length of the projection lens. A chart showing projection distances, lens focal lengths and picture sizes is a useful aid to planning. (Figure 4.) Where funds permit, a selection of two or three projection lenses, of different focal lengths, should be ordered with the projector. There are available, lenses of variable focal length - usually supplied with the more sophisticated machines. These are known as 'Zoom' lenses. Such lenses, whilst more expensive than a single normal lens, are probably no more expensive than a selection of different lenses and much more flexible. A zoom lens can be adjusted to vary the projected picture size to fit the screen, without moving the projector. It is particularly useful for presentations in the field where differing room sizes may be encountered.

Figure 4

Projection Distance Table The following tables shows the distance from the screen at which to set up your projector for a given screen size a given slide aperture size (nominal) a given lens The distances given are the lens to screen distances					Focal length of lens in mm	28				35			
					Slide aperture size in mm	28 x 28				24 x 36		28 x 28	
					Screen width in inches	Lens to screen distance ft in				Lens to screen distance ft in			
					12	1 0				1 0		1 1	
					18	1 9				1 6		2 0	
					24	2 0				2 0		2 4	
					36	3 3				3 3		4 0	
					48	4 3				4 3		5 6	
					59	5 3				5 3		6 6	
					80	6 0				6 0		7 9	
					78	6 9				6 9		8 6	

Focal length of lens in mm	60				85				100				150			
Slide aperture size in mm	24 x 36		28 x 28		24 x 24		40 x 40		24 x 36		28 x 28		24 x 24		40 x 40	
Screen width in inches	Lens to screen distance ft in				Lens to screen distance ft in				Lens to screen distance ft in				Lens to screen distance ft in			
36	5 4	8 8	7 2	4 9	9 10	8 11	9 11	6 1	8 8	11 5	12 8	7 10	12 8	18 0	17 9	11 2
48	6 11	8 9	9 10	6 5	9 3	11 11	13 4	8 3	11 11	15 2	18 7	10 8	18 11	21 9	23 9	14 11
59	8 5	11 2	12 0	7 5	11 11	15 5	17 0	10 6	14 8	18 10	20 10	13 2	20 8	26 7	29 4	18 6
69	9 9	12 10	14 3	9 0	14 10	19 2	21 5	13 4	17 1	21 9	24 2	15 4	24 5	31 2	34 5	21 7
78	11 0	14 2	15 3	9 10	18 8	20 11	23 8	14 7	18 2	24 10	27 8	17 4	27 8	35 3	39 2	24 6
90	13 3	18 9	18 7	11 6	19 5	26 0	27 9	17 6	22 9	28 8	32 4	20 4	32 5	41 5	46 1	28 7
104	16 1	19 3	21 9	13 7	22 2	28 8	31 8	19 10	28 11	33 1	37 3	23 2	37 5	48 8	53 2	33 6
116	18 10	20 8	24 3	15 3	24 7	31 7	35 0	21 10	29 1	37 0	41 3	25 9	41 9	53 11	62 1	37 4
122	17 5	22 11	26 0	16 0	25 8	33 2	37 0	23 1	30 8	38 10	43 3	28 11	44 2	56 0	66 4	41 8

	180				250				70				120			
	ft in	ft in	ft in	ft in	ft in	ft in	ft in	ft in	ft in	ft in	ft in	ft in	ft in	ft in	ft in	
36	18 4	21 2	23 8	14 9	22 2	27 11	31 8	16 9	8 6	7 11	8 2	10 5	13 5	15 1		
48	21 10	27 11	31 4	18 7	29 3	38 0	42 11	26 5	8 0	10 9	12 0	13 11	17 9	20 5		
59	27 3	32 4	39 8	23 3	36 1	46 2	52 0	32 1	9 11	13 0	14 7	18 9	25 7	28 11		
69	30 10	38 8	44 5	27 5	41 0	53 1	59 0	38 3	11 7	15 5	17 2	18 9	26 7	28 11		
78	33 0	43 9	47 2	30 4	44 10	57 8	64 10	40 6	12 8	18 10	19 0	21 8	28 4	31 5		
90	40 3	51 6	56 8	36 9	53 2	66 5	77 8	47 5	18 0	18 8	22 2	26 8	33 5	37 10		
104	48 0	59 3	67 8	41 5	61 10	78 11		55 4	17 7	23 0	25 8	28 7	37 8	42 10		
116	51 5	66 6	75 8	46 2	68 8			61 6	19 3	25 3	28 7	31 7	40 8	46 3		
122	54 3	71 0	79 10	48 3	72 2			64 3	20 2	26 4	29 7	34 8	44 10	50 2		

With the 24 x 36 mm format, the height of the picture will be 2/3 of the screen width, with the 18 x 24 mm format it will be 1/2 of the screen width.

(Source: Kodak Limited)

3. Check that the slides have been loaded correctly in the magazine. Where the simple hand-operated slide projector is being used, make sure that the slides are in proper order, preferably in a wooden slide box. The slides should be numbered with the white labels fixed to the upper right-hand corner (as previously described).
4. Lecture or teaching notes should have been prepared for use by the Lecturer. The number and description of each slide should be written into the lecture notes to ensure smooth continuity. Often the lecturer will find that subject headings together with each slide will suffice if the subject is well known to the lecturer. When an assistant is used to operate the projector, a copy of the notes should be provided for him. Of course, where automatic remote-control projectors are used, no assistant is necessary.
5. Make a final check before the presentation, see that a spare lamp for the projector is at hand. Ensure that any cables connecting the projector to the mains supply are laid so that no-one can accidentally trip over them. See that someone is available to switch off the room lighting when necessary.

Making Slides from Composite Graphic Originals.

A simple method for the production of 35/mm slides by direct photography with a camera has been detailed. Where more sophisticated photographic and graphic skills are available, slides can be made, combining graphic and photographic material.

A simple example of this technique would be the production of a slide which contains a colour photograph, together with written legend such as a title and a slide number appearing in the bottom right-hand corner when projected onto the screen. This is achieved by making up a composite graphic carrying all the information and then re-photographing it onto a 35/mm frame. There are two methods of photography, depending on the number of copies of each slide needed. The composite should be photographed onto negative colour

film from which any number of positive colour prints can be duplicated. Since 35/mm cameras take up to 36 pictures in one loading, a complete run of 36 negatives can be produced. However, to do this, there must be full colour film developing facilities as well as printing equipment available and such facilities are normally available at a central processing laboratory. The laboratory will also cut each frame of print film and mount it into a slide holder, usually the glass type. Where such facilities are not available, it is still possible to produce slides from composite graphics using reversal type colour film and sending it away to the nearest processing station. A composite original is made up by using a reasonably large blank white or black card, depending on the subject matter. The size of this card should be at least 10" X 8". A colour photograph can be mounted on the card and any additional graphic material drawn on the card in different colours, by hand. Thought must be given to layout so as to produce an effective slide. The composite can then be photographed using a 35/mm camera capable of focussing sufficiently close so as to fill the frame area with the composite. A single lens reflex type camera is essential for this work.

Adding Sound to Slide Programmes.

Most of the more sophisticated automatic slide projectors are equipped for automatic synchronisation of sound from a tape or cassette recorder/player. The programme information is carried on one of the two tracks on the tape- e.g. commentary, the other track carries signals or 'pulses' which are recorded on the tape at the exact moment a slide change is required. These pulses are fed by a connecting cable to a socket in the projector and in this way each slide changes automatically at exactly the correct moment during the programme. However, it is not possible to make use of any ordinary standard tape or cassette recorder. A specially made tape machine, provided with the additional record/playback head to record and replay the pulses is required. Whilst reel-to-reel machines of this type can be found, the Philips Cassette type machine is most popular because of its low cost and portability. Such cassette machines are available for mains or battery operation and can be supplied with a pulsing unit so that it is possible to record and pulse a slide programme on the spot. This system is very useful when an experienced lecturer on a subject is not available because a trained assistant can present

a programme with a pre-recorded commentary made by the subject expert. However, it must be emphasised that whilst information can be presented accurately in this way, it can never be as effective as a programme delivered by the lecturer in person. The lecturer can be flexible and can retrace where he feels it necessary, as well as being able to answer questions and deal with a discussion on the subject. Operating instructions for slide/tape-sound synchronism with cassette tapes are provided with the cassette recorder and pulsing equipment.

Film-strip Projectors.

The Filmstrip projector employs exactly the same optical principles as the Slide Projector but instead of separate 35/mm slides being used, the programme material for the visual is carried on a length of 35/mm film. The film is exactly the same as film used in 35/mm motion pictures, except that the individual frames are projected as still pictures. The frame size of the picture is 24 X 18 mm, i.e. half the size of the frame size in a 35/mm slide. There is no slide carrier in a filmstrip machine. This is replaced by a small roller on an arm at the top of the machine from which the 35/mm roll of pictures is fed into the projection aperture. There is a simple sprocket drive which engages with the perforations on the edges of the film, thus feeding each frame into position in the projection

aperture. Below the aperture there is a take-up roller onto which the leading end of the film is threaded. In the simple type of projector, frames

are advanced by hand, by turning a winder which is linked to the sprocket wheel. Fig. illustrates the layout of a Filmstrip Projector.

Just as with the Slide Projector, the Filmstrip Projector is available in a range of models from the simple hand-operated machine to a fully automatic projector fitted with tape/sound and pulse equipment so that the presentation can be automatic and in synchronism, sound with picture. The same type of special cassette recorder and pulse unit as used for slide machines, can be used with the automatic Filmstrip Projector. The more sophisticated models employ small cassettes to hold the roll of film which are threaded by the machine automatically. There are advantages and disadvantages in considering the use of this type of still picture projector. The main advantage lies in the fact that the programme carrier, i.e. the length of 35/mm film can carry a large quantity of single frames. There are 16 frames to each foot of 35/mm film and therefore it is easily possible to have a series of 100 or more frames in only a few feet of film which takes up very little space and is easily stored. However, any re-arrangement

Figure 1

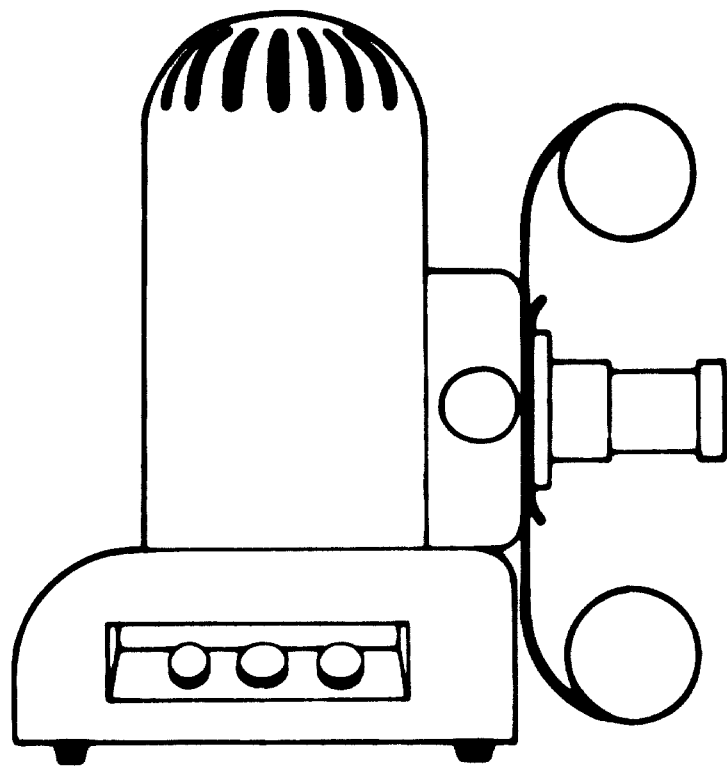

of individual frames in a filmstrip programme is not possible, without re-making the entire programme. With slide projectors and slides, single slide alterations and updating is easy. The composite graphic originals are prepared in exactly the same manner as for slides. Unless there are very complete photographic facilities available, the filmstrip is not the sort of visual programme that can be produced by the training personnel. Filmstrips have to be photographed onto the 35/mm negative with a special 35/mm rostrum camera. This is generally carried out by specialist houses or photolaboratories in the industrialised countries. Therefore, the filmstrip projector is recommended only in cases where there are suitable published filmstrips to suit a training course. For local production, slides are to be preferred.

SUMMARY

There is no doubt that projected slides or photovisuals have become an extremely effective tool in solving many present-day communications problems. They are used widely in education, business and industry and governments - people in all fields are making more and more use of these kind of visual aids because of increased awareness of the need for good communication.

There is a wide choice of equipment to choose from to suit every need from the simple hand-operated projector to the fully automatic machine with synchronised sound from a tape cassette. The only limitation is that slide projectors present still pictures and if movement is required or is necessary, then a motion picture projector must be used.

AUDIO VISUAL TECHNIQUES
FOR INDUSTRY

PART TWO
TECHNIQUES AND TOOLS

CHAPTER FOUR
MOTION PICTURES

MOTION PICTURES.

Introduction

Since the invention of the motion picture film at the end of the nineteenth century, 'movies' have been regarded by the public mainly as an entertainment medium. Nevertheless, almost from the time of their invention, the potential of the film was recognised as a teaching medium. However, in those early days, all motion pictures were made on 35/mm film and the projection equipment was cumbersome. Since the main financial objective at the time was for the films to make money as a form of entertainment medium, little thought was given to making use of film as a means for instruction. Certainly, the early silent newsreels were an example of the use of film for informational purposes. Then the Documentary film was developed, even before sound films were possible. The term 'documentary' was first used in regard to a special kind of film by John Grierson in 1926 when he reviewed a film made by Robert Flaherty entitled 'Mona' - a film about the South Sea Islands. The difference between an entertainment film and a documentary is that the former employs actors and the latter, real-life situations and people. Grierson defined his term 'Documentary film' as 'the creative interpretation of reality'.

The late John Grierson established the documentary film firmly in the early 1930's when he opened the British Empire Marketing Board Film Unit and following that the British G.P.O. Film Unit. By then, the sound film had emerged and the G.P.O. Film Unit became known internationally as producers of excellent documentary films which were used as a Public Relations and information exercise to inform on the activities of the British Post Office. 'Night Mail' is a classic example where the talents of the documentary director were combined with those of the poet W.H. Auden and the composer Benjamin Britten. The result, ^{was,} an account of the journey of the night mail train from London to Glasgow.

The G.P.O. Film Unit pioneered the use of the 16/mm sound projector. A number of projectors were acquired together with all the necessary accessories, speakers, screens etc. Thus they were able to travel the country, giving shows of their films to Womens' Institutes, schools, universities and the like. This established the non-theatrical use of film and the popularity and use of the 16/mm projector grew rapidly. Documentary films were and are used for conveying to the viewer, a first-hand experience of a subject. However, they did not teach specifically.

Rather, they gave background information on a subject and stimulated interest and a desire to learn more. A further and natural development was to produce a visual aids 'package', consisting of a documentary sound film, a set of slides to teach detail of the subject as well as a carefully prepared set of lecture notes which could be given to the trainee. The Shell International Company were producing this kind of training package in the late 1950's. It was from this background that the training film in various forms emerged. 16/mm projectors became more sophisticated and highly portable and then the 8/mm and Super 8/mm rear-projection single-concept loop machines were developed. Before going into the technical details of the variety of motion picture projectors available, it is necessary to have an understanding of the different types of training film and more importantly their value in terms of teaching and retention of the subject matter.

1. 16/mm Industrial Training Films.

Many large industrial companies throughout the world have produced films, designed to train employees at all levels on a specific subject. These films are usually of a running time of between ten and twenty minutes. Generally, they are screened in projection theatres with a cinema-type atmosphere. Whilst films like these

have been produced by professional film makers who will have made the film in close collaboration with a subject expert, there is no guarantee that the film will, in fact, teach. Like the documentary it may only give the viewer background information. The reason for this is that film, by its very nature, is fleeting and it is impossible for the viewer to remember the detail of the first few minutes of a training film, after seeing a whole twenty minute programme. It is for this reason, that a more simplified type of training film is recommended. The subject is broken down into logical steps, each sequence running no longer than four or five minutes. In this way, the viewer receives the information a little at a time, with the possibility of pausing after each step and having a discussion with the subject expert. Even existing full-length training films could be presented in this manner, pausing after each four or five minutes so that the information can be digested and retained.

2. Single-concept Loop Films

The development of 8/mm motion picture film (initially for the home movie maker) introduced a new use of film for industrial training. Recognising that a full-length film could not be retained a number of training film production houses produced simple motion pictures to train an individual or group in one concept of a subject. Initially, this had been done by making a continuous loop of a few feet of film and screening it on a 16/mm projector. For example, a close-up scene of a demonstration of the correct way to file a piece of metal with a hand file. This one simple action could be shown continuously so that the viewer could see it repetitively and thus absorb the training. A specially designed self-contained 8/mm projector was produced by the Technicolor Company, incorporating built-in rear-projection. The 8/mm film loop was housed in a special endless loop cassette thus obviating the need for threading. Many thousands of these 8/mm loop machines were sold into commerce and industry throughout the industrialised

countries. Extensive libraries covering a multitude of subjects on 8/mm single-concept loop were set up both in Europe and the U.S.A. Sadly, many thousands of these 8/mm projectors now lie covered in dust, unused. This happened for several reasons. There were mechanical problems with the early 8/mm loop projectors. Some industrial training people bought these machines at the time, not so much because they felt that they could put them to good use for training, more perhaps because they were attracted to the novelty of the system. The lesson to be learnt is that any film display system must be chosen carefully and it must be remembered that no gadget or new device can replace a properly prepared training course which integrates the use of film with other elements, the most important being the training officer or lecturer. The 8/mm single-concept loop films and projectors were silent - they depended on the presence of the subject expert as well as teaching notes. Nevertheless, many of these machines are still in use and single-concept loops are available in the libraries of the production houses. (See Part Three)

Having discussed the development of the motion picture as a means for training, with special regard to the possible shortcomings, there is no doubt that where the presentation of movement is needed, film is indispensable. The motion picture can also compress time, i.e. a process which in real time might take say thirty minutes, can, by the skills of the director and film editor, be presented in a much shorter time of a few minutes only. For the 16/mm sound projector, there is a mass of subject matter available from film libraries and catalogues of the subjects can be obtained from these libraries on request. (see Part Three)

Motion Picture Projectors.

The 16/mm projector is the most widely used motion picture machine in training and education. Modern machines are equipped with very powerful quartz-halogen projection lamps capable of projecting very bright pictures. Most modern machines are self-threading, it being necessary only to insert the leader of the film into the threading slot and from then on, the machine threads the film through the picture and sound gates automatically. Various models can be obtained. The standard type of projector is equipped to reproduce sound films carrying an optical sound track. There are also machines which will reproduce both optical and magnetic

sound. Although most 16/mm films from film libraries are printed with optical sound, in some cases magnetic sound reproduction is useful although not essential. Magnetic sound reproduces at higher fidelity than optical sound. The most comprehensive type of 16/mm projector is equipped with optical and magnetic sound reproduction and also has facilities for recording magnetic sound. This type of machine is recommended since it is possible to record new commentaries onto existing films, in a different language. Fig. 6 illustrates the layout and film path of a 16/mm projector.

Modern machines will accept spools of 16/mm film from 400 feet to 1600 feet in length with a maximum running time (at 24 frames per second) of 45 minutes. The same conditions for projection, as outlined in Chapter Three (for slides) apply in general. When using a 16/mm projector, ensure that it is placed well to the back of the room and so arranged that the beam from the lens projecting the image, cannot be obstructed by the heads of the viewers. Ensure that there is an extension speaker which matches the output of the projector amplifier, sited close to the screen. Although modern machines have built-in loudspeakers for the sound, this is only intended for pre-viewing a film in a small room.

Figure 1

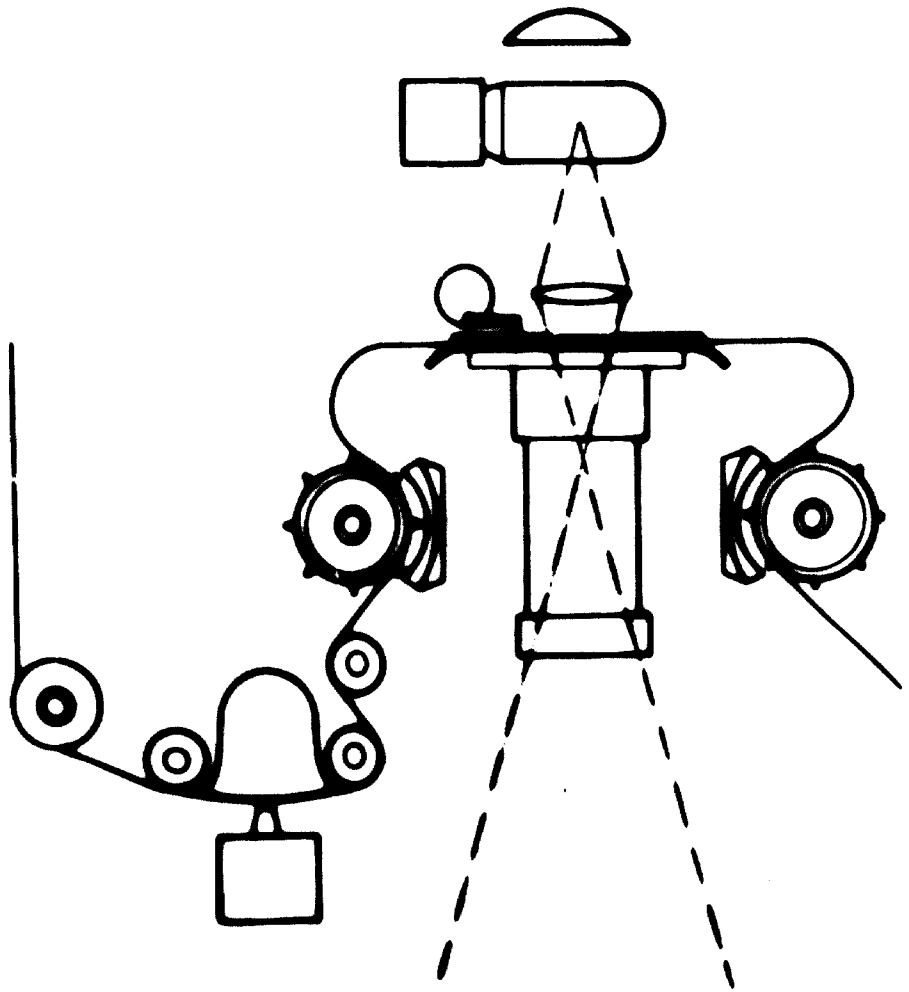

For the projection of sound films in a lecture room, it is essential to have the sound source from the screen end of the room. The projector's built-in loudspeaker alone would mean that sound would be heard from behind the audience and at low quality. Ensure that the sound level from the screen speaker is at a sufficiently high level to be clearly heard by those at the back of the room. Keep in mind that people at the back of the room will hear the noise of the projector much more than those in front of them. Try the film out before a show, listening to the sound from different parts of the room.

With modern 16/mm projectors, it is not difficult to train an assistant to operate the machine. Instruction manuals are provided with the machines, they are very clear and usually in several different languages. The decision as which kind of projector to buy will depend on funds available and the needs of the training manager. There are several manufacturers of 16/mm sound projectors throughout the world.

It is best to check with the nearest photographic retailer to find which makes are available. Specify the local electric current supply details when ordering. Whichever model is chosen, ensure that adequate supplies of spares are available locally, as well as servicing and repair facilities.

Only simple maintenance is needed for modern 16/mm projectors which any non-skilled person can carry out. Precise detail of this is given in each instruction manual with the machine. Generally, it is a question of keeping the film path clean, as well as the sound heads and the projector lens.

8/mm Film Projectors

The standard 8/mm projector was developed originally for the amateur movie maker. In 1965, the Eastman Kodak Company introduced a new format for 8/mm film, the Super 8/mm film. This employs the same width as the old standard 8/mm, but by re-arranging the position and size of the sprocket holes, a 50% larger picture area per frame was possible. This increased the quality and definition of the projected picture enormously. Since then, apart from the amateur moving over to this new format, there have been rapid developments in the design and production of projection equipment for screening Super 8/mm film. A number of existing hardware manufacturers produced a Super 8 version of the endless loop, cassette loading rear-projection machines. New machines came along, capable of presenting up to twenty minutes of programme from an endless loop cassette, with sound and completely automatic. However, with a number of different manufacturers, all making different cassettes to contain the film, there is a compatibility problem.

Since each manufacturer's machine had a specially designed cassette, only cassettes of that make could be used on the machine. This was perfectly acceptable in organisations using only their own programmes. Beyond this use, interchange of software is impossible without having the Super 8/mm film unloaded from one cassette and re-loaded into the cassette of a different make of machine. This operation is time-consuming and costly.

A few years ago, two major manufacturers introduced a new type of cassette, not of the endless loop type, but simply a plastic container for a reel of Super 8/mm film. This cassette was designed to fit onto a new type of projector which automatically threaded the film from the cassette to the take-up reel. Some machines automatically rewound the film at the end of the reel. With few exceptions, these new cassette projectors were designed for front-projection only. The two standards of cassette of the reel-to-reel type have been established by the Eastman Kodak Company for one type, and Bell & Howell for the other. One type is, of course, not interchangeable with the other. This is a pity, because it would have been far more sensible for these two large corporations to have agreed upon a standard cassette and projector auto-thread to create international compatibility.

Therefore, whilst there are a number of interesting Super 8/mm endless loop type machines with built-in rear-projection screens on the market, before deciding to acquire one, careful consideration should be given to:-

- (a) The problem of cassette non-compatibility between the various different makes.
- (b) The special equipment and skills required to load a film into any endless loop cassette. This is not practical for the normal visual aids unit personnel and indeed, in the industrialised countries, this process is always carried out either by a specialised film laboratory or by the main distributors for the particular make of machine.

Nevertheless, the Super 8/mm projector is an inexpensive and highly portable machine for the presentation of sound or silent films. There is a choice between modern reel-to-reel Super 8/mm sound machines, which, whilst not being of the cassette loading type, will thread the film automatically through the picture film path onto to take-up spool. There are a number of manufacturers of this type of machine and many of them produce projectors of this type capable not only of reproducing the magnetic sound track carried on the edge of the film, but also capable of recording sound onto this track known as 'magnetic stripe'.

Similarly, the new machines accepting the Kodak and Bell & Howell reel-to-reel cassettes respectively, can be supplied with magnetic sound record/replay facilities. This type of Super 8/mm projector is recommended because the film is always protected from dust by the cassette and there is much less risk of mechanical damage, since the whole threading operation is automatic. These machines are simple to operate - even for a child. All modern Super 8/mm projectors can be supplied with zoom projection lenses as standard. Although a number of film libraries have made some of their titles available in Super 8/mm form, there has not been, unfortunately, a significant quantity of titles of up-to-date sound programmes in this form, the preference remaining for 16/mm prints. This is a curious state of affairs, since Super 8/mm colour prints cost less than half that of an equivalent length of 16/mm; and modern Super 8/mm projectors are capable of projecting a large, brightly illuminated image, only slightly less well defined than a 16/mm image. Education, industry and commerce in the industrialised world are much more interested in the new electronic videocassette systems - yet these systems cost at least six or seven times the amount of a good Super 8/mm cassette projector. (See Chapter Five)

An Effective Use for Super 8/mm

Regardless of the availability of training films in the Super 8/mm format, the acquisition of a Super 8/mm sound projector with recording facilities together with a Super 8/mm film camera can form a very useful tool for industrial training when local subjects involving movement need to be presented. With this equipment, it is possible to film simple subjects in motion or single-concept material. There are many makes of Super 8/mm cameras to choose from. There are simple, inexpensive cameras requiring no particular skill on the part of the user as well as sophisticated cameras with zoom lenses and macro-photography (the photography of small objects in large close-up) facilities. No matter which camera is chosen, they all accept a standard Super 8/mm film cartridge containing 50 feet of unexposed film. The cameras need no threading - simply drop the cartridge into the film chamber in the camera and the equipment is ready for use. Modern Super 8/mm film cameras are also equipped with automatic exposure systems and a notch in the cartridge of film automatically sets the system to the correct exposure setting. Different emulsion speeds are taken care of by the notches in the cartridge. Throughout the world, there are

processing stations for the most widely used Super 8/mm reversal colour film - Kodachrome II. The cost of processing is included in the price of the cartridge of film and processing usually takes only a few days plus the delivery times by post. The standard frame projection speed for Super 8/mm is 18 frames per second compared with 24 frames per second for 16/mm. However, most Super 8/mm cameras and projectors will run at 24 frames per second if required.

Once the decision has been made as to which equipment is to be purchased- and this will depend upon funds available and the work to be done - the Super 8/mm system can be used for training. It is important at this stage to recognise that film production is a skill requiring professional expertise and therefore, no attempt should be made to 'make a movie' in the training context. Rather, the camera can be used for filming simple operations which will be useful for presentation as a part of a teaching programme, where the subject calls for movement. For example, it is not very difficult to film a scene showing an operator using a lathe. Use should be made of close-up detail and it is best to confine the action to one planned operation. Several scenes of this could be photographed from different angles, or

perhaps, the same action could be repeated over and over whilst the camera is running the full 50 feet of film, which at 18 frames per second will last for 3 minutes and twenty seconds. When the processed film has been returned by the processing station it will be on a 50 foot spool, ready for use. This spool will fit directly onto the ordinary reel-to-reel projector or in the case of the Kodak or Bell & Howell cassette machine, it is simply fitted into the 50 foot cassette and is then ready for projection automatically. The subject matter can then be integrated into the particular training lesson and the film sequence shown as a silent film, with the lecturer delivering the commentary on the spot, or, providing that magnetic striping facilities are available, the film can be 'striped' and a commentary can be pre-recorded, using the recording facilities on the projector. In many situations, silent film presentation will suffice. Pre-recorded films can be very useful for group training where the trainees may review the programmes as often as they need in order to acquire information about new skills.

The usual precautions regarding local mains current should be taken before ordering this kind of projection equipment. The nearest local photographic dealer should be consulted as to the best available

cameras and projectors. Ensure that there are adequate local servicing facilities. Make sure that at least two spare projection lamps are ordered with the projector. Power for Super 8/mm cameras is derived from small batteries which fit into the camera which is thus self-contained. It is as well to order a few spare sets of the correct type of batteries for the camera.

Summary

For screening motion pictures from the film libraries offering professionally made industrial training film programmes, a 16/mm sound projector is indispensable.

A Super 8/mm projector and camera can be a useful tool for the industrial trainer who uses it in the simple manner recommended. The decision as to whether to buy a silent or sound machine will depend not only on local needs but also on local resources for applying the magnetic stripe. The reel-to-reel cassette type of projector is to be preferred because of its simplicity in operation and safe film storage. The largest volume manufacturer of Super 8/mm projectors is **Eumig** (Vienna) with world-wide distribution and service. There are new developments taking place in Super 8/mm machines by the Eastman Kodak Co but these are so far available only in the U.S.A.

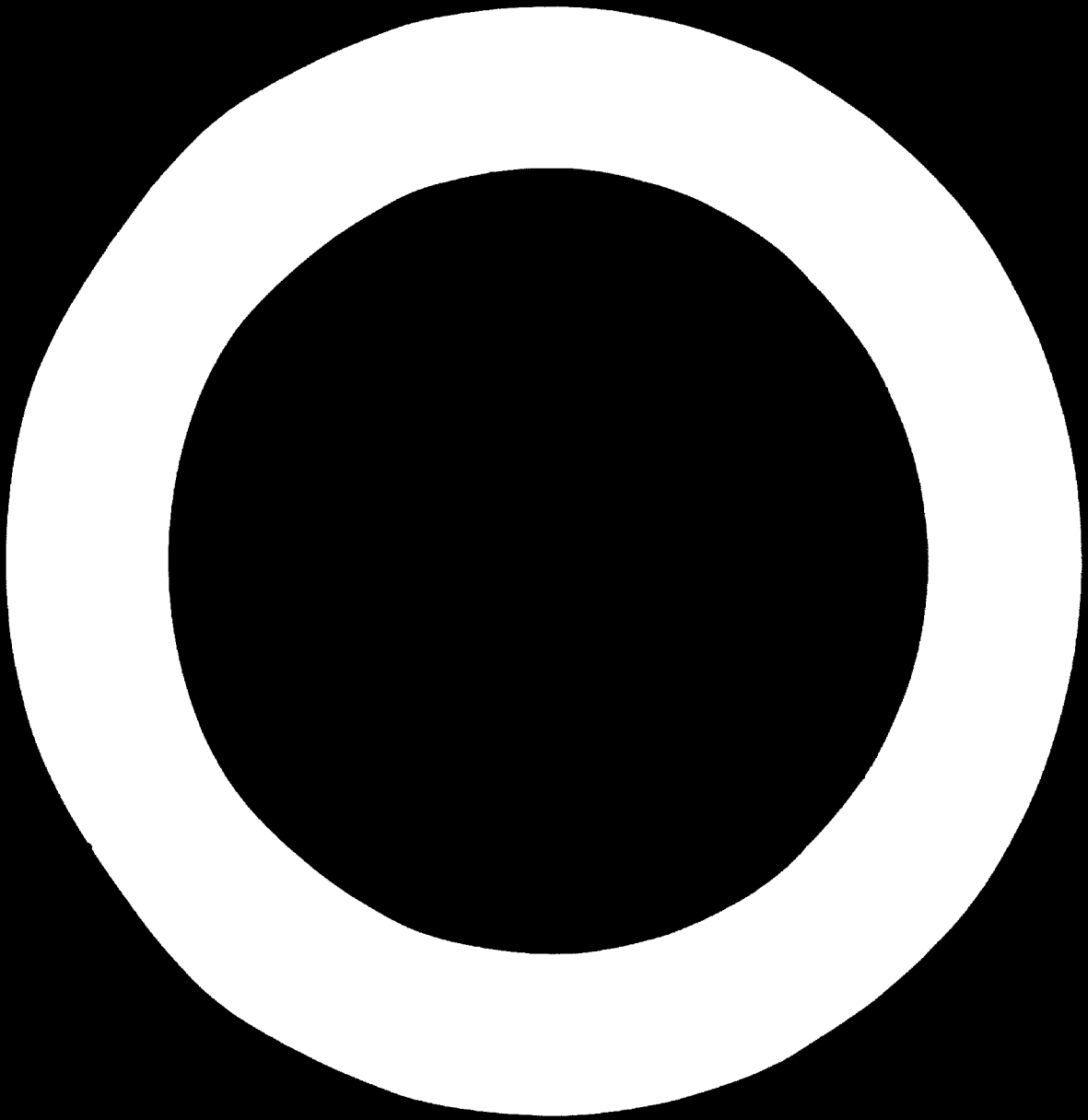

AUDIO VISUAL TECHNIQUES

CHAPTER FIVE
ELECTRONIC MEDIAFOR INDUSTRY
PART TWOThe Videotape Recorder

TECHNIQUES AND TOOLS

This is a recording machine, very much like a reel-to-reel sound tape recorder. However, there is an additional recording and playback head together with the necessary electronic circuits to allow an electronic recording of a TV picture to be made. The accompanying sound is recorded on the edge of the tape, whilst the picture is recorded on the full width of the videotape. The Videotape Recorder, known as a 'VTR' can be used in two ways:-

- (1) A TV camera can be plugged into a socket in the VTR and pictures of anything appearing in front of that camera are recorded. The sound is recorded via a microphone which is also plugged into the VTR. This means that synchronous sound with picture, either of people speaking or commentary are recorded simultaneously and immediately after the recording is made, the tape is rewound and the recording played back via a TV set.
- (2) Broadcast television programmes may be recorded on a VTR when it is connected to a special TV receiver/monitor which has output sockets for sound and vision which

through connecting cables are fed into the sound and vision inputs of the VTR. For replay, similar connecting cables and sockets carry the VTR picture and sound outputs to the VTR.

VTR machines are available for recording in black and white only, or, at a considerably higher price, can be supplied capable of recording colour TV pictures. With few exceptions, most of the industrial training applications call for black and white recordings only. When colour is essential, a considerably higher cost for equipment must be provided for. Not only will the VTR colour machine be more expensive, so also the TV camera for colour. Before discussing the practical applications of VTR equipment in industrial training it is as well to have an understanding of the problems of compatibility between machines of different make as well as between the broadcast TV systems throughout the world.

Compatibility between different VTR machines

There are a number of different manufacturers of VTR machines, employing differing tape widths and standards both in black and white and colour. Some machines use for example, half-inch width videotape, others three-quarter-inch and the more expensive machines use one-inch width. Generally, the wider the videotape, the higher quality and higher definition is the resultant recorded picture.

VTR machines used for broadcast purposes in TV stations employ a videotape width of two inches. For industrial training purposes, the type of machine using half-inch videotape is perfectly adequate with a black and white recording. Providing the VTR machine is used solely for recording and playback in one training location, no problems of compatibility will arise. However, there will be problems in the interchange of tapes from one system to another. This means that a Videotape recorded say in the U.S.A. on a half-inch VTR cannot be played back on a machine of the same make in Europe. The reason for this is that there are different TV standards between different countries, much in the same manner that electric mains current varies from country to country. Without going into technical detail, there are two colour TV standards in Western Europe - the PAL 625 line system and the SECAM 819 system (France). These transmissions also apply to black and white reception. Neither are compatible one with another. VTR machines sold in each area are designed to match up to the particular TV system. In the United States of America, a different TV system from any European standard is employed - the NTSC 525 line system. When VTR machines are to be used for recording broadcast programmes (subject to local copyright laws) the VTR machine will have to match the local TV standard. It will be seen from this, that there is a serious problem of international compatibility in the interchange of information via

VTR tape recordings. Even when VTR machines are used for recording on-the-spot programme material with the use of a simple black and white TV camera, videotapes made can be replayed only on exactly the same make and model of VTR machine. Even then, there is sometimes a problem in reproducing tapes recorded on one VTR machine to be replayed on another identical VTR at another location. Sometimes it is necessary for a trained engineer to align the reproducing machine in order to replay a tape made on a distant machine of the same type. Therefore, as a programme carrier for information in industrial training, for international exchange, VTR is not recommended. Motion picture film is an internationally compatible carrier and apart from its use in a projector, film can also be transferred to videotape for any local TV system, providing there is a TV station within reach with the necessary transfer equipment.

Practical Applications of VTR Systems

Providing it is used in a simple way for certain industrial training applications, a black and white half-inch VTR machine, together with a simple Videcon type portable TV camera equipped with a zoom lens, can be a useful tool. The size of TV monitor is a question of personal preference but an 18 inch screen size TV monitor is recommended as minimum. This is the basic equipment necessary for black and white VTR.

The advantage of this system is that recordings of audio-visual material may be made then replayed immediately. This may be of particular value in areas where there is no access to motion picture film processing facilities, yet where there is a definite need to record moving pictures for training.

The TV cameras supplied for use with these relatively low-cost VTR systems are very sensitive so that pictures can be recorded without the need for any additional lighting in interior locations such as workshops, factories and the like.

Suggested applications are:-

- (1) Recording pictures of specific workshop and machine operating techniques for training. (most VTR machines in this area are equipped so that commentary may be recorded after the picture and during a replay of the picture)
- (2) Recording details of subjects which would otherwise be impossible to present to a group of trainees e.g. recognition of faults during a particular manufacturing process.
- (3) Presenting a talk or lecture when the lecturer is absent. i.e. the talk is pre-recorded by the subject expert in sound and vision for replay at a later time.

- (4) For training personnel in delivering talks and lectures (see Chapter 2)

THE VTR can be used so that the trainee speaker can record himself and afterwards replay the VTR recording and by this means analyse his performance with a view to improving his presentation.

- (5) For recording group discussions e.g. after a training course. Whilst it is true that this could also be done by simply using a sound only tape recorder, in some instances, having the discussion in vision too, could be valuable, particularly where other visual aids are being referred to, such as Chalkboards, Flipboards and the like. This kind of record can prove useful to the training officer in analysing a particular training course and its effectiveness.

Obviously, many other applications will occur for those making use of VTR equipment.

Portable VTR Equipment.

Some manufacturers supplying half-inch black and white mains-operated VTR also supply matching portable VTR sets. These consist of a small battery-operated VTR which can be slung over the shoulder, together with a light-weight TV camera equipped with a zoom lens. This equipment can be very useful when recordings in the field are needed, which can

be replayed later at the Training Centre on the larger mains-operated equipment.

Practical Hints

VTR equipment should be handled very carefully since it is complex and has delicate electronic components. Ensure that any equipment to be used in tropical conditions will operate satisfactorily under such conditions - many VTR machines will not operate satisfactorily in high temperatures and humidity. Make no attempt to produce material comparable with professionally produced broadcast TV - rather make simple use of the camera, remembering that editing is not possible. Make good use of close-ups which are much more meaningful on the small TV screen. While most VTR TV cameras can be hand-held, wherever possible make use of a tripod so as to record steady pictures - a wandering view can be distracting. Maintain and clean the equipment according to the manufacturer's recommendations. Usually this means cleaning the tape path and guide rollers. Take great care to avoid damage to the video heads - these are extremely delicate. The instruction book with the equipment will give full details of this. Specify the local mains current and local broadcast TV standards when ordering VTR equipment. Check that servicing facilities are available from the supplier. Make sure that supplier carries spares. See that all connecting cables are supplied, finally,

give careful thought, before deciding to install a VTR, to its real potential value in the training set-up. Remember, although this kind of audio-visual equipment is novel and has the attraction of making local TV pictures, it is very much more expensive than any other aid so far detailed in this Manual and equally, there is very much more to go wrong. This is of particular importance in remote areas where servicing in the event of faults or break-down would be impossible.

Closed Circuit Television

This is known as CCTV (an abbreviation) The equipment consists of a TV camera which, in its simplest form, is fed by cable into a TV monitor. The applications of CCTV in the industrialised countries is for example, in hospitals which have medical schools, or as a 'remote eye' watchdog in department stores or monitoring industrial processes. All of these applications make use of the TV camera to feed pictures of whatever the required information might be, to TV monitors - sometimes several in different parts of a building, so that others can see what is happening in front of the camera. The value is obvious in medical training, where medical students may see details of surgical techniques without having to be in the operating theatre.

CCTV as a policing system is also an obvious application. However, in industrial training, it may only be of value in a very large training centre when it is valuable to transmit TV pictures to a number of lecture rooms at the same time. This technique requires more than just a TV camera and monitor. When a number of monitors are to be fed from a single camera source, then additional electronic equipment will be needed such as vision and sound booster amplifiers. Should there be a need for this complexity of installation, it is essential that a CCTV engineering expert be consulted and that proper planning, costing and training of operational personnel be investigated.

SUMMARY

Whether VTR or CCTV is being used as an instructional tool, there are a number of differences in technique as far as an instructor appearing in front of the camera is concerned. Talking to a TV camera is impersonal and quite different from addressing a group of people. Voice delivery is quite different, in that there is no need to project the voice, since sound is being recorded via a microphone close to the speaker - often a small microphone worn in a sling around the neck. White clothing appears too white on a TV system and therefore, white shirts should

not be worn - coloured shirts and clothing are to be preferred. Since there is a television monitor usually within the view of the speaker recording his lecture, there is always the temptation to glance at his own image in the monitors during a recording. This must be avoided. Always address the camera lens. References to detailed books on TV techniques will be found in Appendix A.

For the small Audio-visual training unit, CCTV will probably be of little value. A VTR outfit may be of value when it is difficult to make normal motion picture sequences, say on Super 8/mm film. However, all this type of equipment is much more expensive than other audio visual equipment and there is very much more service needed as well as the greater possibility of the equipment being out of action. Compatibility problems must also be considered before making a final decision to make use of VTR or CCTV. It is an advantage if there is someone available with electronic experience when these electronic systems are to be used. When ordering VTR equipment, the supplier should be consulted as to which spares to order at the time as well as ordering adequate supplies of videotapes. VTR and CCTV equipment depends upon an A/C mains supply (except for the portable equipment which is battery operated)

VIDEOCASSETTE EQUIPMENT

Over the past five years or so, there has been a proliferation of news reports and manufacturers' promotional publicity on what has been termed, "The Communication Revolution". All these reports and promotions referred to the Videocassette. Most of the new systems being promoted were really only in the development stage and all of them failed to meet the dates for general availability. There has been something amounting almost to hysteria in certain sectors of the training and education fields in hailing the Videocassette as the answer to all training and communications problems. This is very far from the truth.

The Videocasstte is, in fact, a refinement of the VTR. Instead of the videotape being carried on spools, it is contained in a specially designed plastic cassette, usually with the feed reel above the take-up reel, all fitted and locked into the plastic cassette. The Videocassette machine works on the same principles as the VTR except that it is only necessary to slot the Videocassette into the machine (known as the VCR), tape threading being automatic. This is much the same kind of development as was made with Super 8/mm film so far as the film container and automatic threading is concerned. All VCR machines now available are

for colour recording and reproduction. They will, of course record and reproduce black and white programmes. VCR machines may be used in exactly the same way as VTR machines. Some models of VCR machines have built-in off-air UHF tuner units with up to six different channels which may be pre-set for local stations. This facility is of value mainly for educational purposes, where schools can record broadcast educational programmes, for replay at times to suit their own curriculae. It is also intended for a domestic market so that users may record TV programmes of their choice. These two applications are irrelevant in industrial training.

VCR machines are subject to all the compatibility problems of the VTR. From the different hardware manufacturers throughout the world, there has emerged two main standards for VCR. One for Europe employing half-inch videotape in cassettes, the other from the U.S.A. and Japan, using three-quarter inch tape in a different type of cassette. One is not interchangeable with the other. The former is known as the EIAJ $\frac{1}{2}$ ", the latter as the U-Matic $\frac{3}{4}$ ". Both types are now being marketed in all parts of the industrialised world.

Just as there is no international standard for broadcast television or VTR there is the added problem of there being two standards of VCR cassettes and systems. The U-Matic type is of higher quality than the EIAJ and the equipment is more robust and trouble-free. But it is very much more expensive. For example, one could buy a 16/mm sound projector, an automatic slide projector with sound tape synchronism together with an overhead projector for a total cost amounting to about half the cost of a VCR machine, with a colour TV monitor. Add a colour TV camera, then the total cost is prohibitive.

For industrial training applications, the only advantage VCR has over VTR is that tape threading is automatic. Normally, black and white pictures with VTR are adequate and keep within a reasonable budget. With VCR, the machine is designed for colour and the cost of this is higher.

Whilst it is true that VCR machines are becoming very popular in the industrialised countries for use in schools, commerce, industry and even the home, at the present state of development and cost they would seem to be an unnecessary luxury for the small industrial training unit. Whilst millions of dollars have been ploughed into the

development and production of VCR hardware, very little capital has been applied to the production of software programmes specially made for this new medium. The present tendency is to have existing colour movies transferred to VCR cassettes, the cost of which is quite high. There seems little point in showing a good training film in colour on a small TV monitor, when it can be screened by 16 or Super8/mm projector onto a large screen. To transfer a motion picture film onto VCR cassette requires specialised equipment to be found only in large colour TV broadcast stations or in special transfer centres in industrialised cities. When more attention and cash is given to the software production for VCR on an international basis, when perhaps new programmes for industrial training will be produced for VCR and made available in all VCR standards, the system may become more interesting for the industrial trainer. Even existing tape/slide programmes with sound could be transferred to VCR tapes. At the present time, the promotion and supply and sales of VCR hardware far outstrips the software supply and it may be some years before the necessary libraries of VCR software are available so as to make such a system meaningful in industrial training. The same problems apply to the newest form of electronic audio-visual reproducer - the Videodisc.

THE VIDEODISC

This system, as its name implies, is for the reproduction of electronic TV pictures in colour from a disc, much like a record-player. The programmes are printed or pressed onto flat discs like long-playing records, vision and sound being carried on the disc. The player is connected to a colour TV monitor and thus the information is reproduced as a colour TV picture with sound. The proposed advantages of this system are that the hardware (player units) will be less costly than a VCR and that the software will also be much lower in cost and can be reproduced economically in quantities just like sound record discs are pressed in large quantities.

So far, there have been two systems of Videodisc player - one which is electro-mechanical, rather like a record-player. A pick-up specially designed for video reproduction, reads special grooves on the disc and thus relays the electronic information to the TV monitor, which converts them into colour pictures with sound. The second system employs laser-beam technology in order to 'read' the disc. Both systems have been heavily promoted by their manufacturers but neither is yet

commercially available. It will probably be a year or so at least, before the Videodisc is perfected and on the market. Even then, it will probably only be of value in the industrialised areas for education and domestic use.

Recording by the user is not possible on Videodisc. The system is for reproduction only. Here once more, the problems of suitable software supply have not been properly tackled. A great deal of further thought, research, development and cash will have to be put into software for the Videodisc. Yet there are obvious applications, such as single-concept presentations and step-by-step training programmes. For the industrial trainer, it is hard to see at this stage just how and where this system will fit in. No doubt, when the hardware and software have been fully developed and is commercially available, it will be of value to those with colour television, as a relatively inexpensive means for presenting training information via the Videodisc. This can only happen when suitable industrial training programmes on disc are available on an international basis.

Meanwhile, the small industrial training unit would be well advised to keep to the more conventional and proven audio-visual aids which have been detailed in the preceding chapters of Part Two of this Manual.

AUDIO VISUAL TECHNIQUES
FOR INDUSTRY

PART THREE

APPENDICES

- A. SELECTED BOOKS AND PERIODICALS.
- B. DISTRIBUTORS OF BOOKS AND PERIODICALS.
- C. INSTITUTIONS AND ORGANISATIONS.

A.

BOOKS AND PERIODICALS

Der Osterreichische Schulfunk, monthly, Vienna IV, Argentinierstrasse.
(Funkhaus).

Dia-Revue: enseignement et vulgarisation des sciences par la
diapositive et la photo, bimonthly, 17 Belle-Voie, Wavre, Belgium.

Enseignement des sciences, Librairie Hermann,
115, boulevard Saint-Germain, Paris-6e.

Ingenieurs et techniciens, monthly, 30, rue Tronchet, Paris 9e.

Radio et TV, monthly, Editions Chiron, 40, rue de Seine, Paris 6e.

Die Umschau in Wissenschaft und Technik, fortnightly,
Frankfurt am Main, Stuttgarter Str. 20/22.

Hobby Club, quarterly, Van Miereveldstraat 1, Amsterdam Z.

Matualidades y cotos escolares de prevision, monthly,
Manuel Silvela 4, Madrid.

Lehrerzeitung, weekly, Zürich 4, Stauffacherquai 36.

Information bulletin of higher and specialized education,
monthly, Mezhdunarodnaja Kniga, Moscow, G-200.

Teacher's gazette, 156 issues per year, Mezhdunarodnaja Kniga,
Moscow, G-200.

Journal of scientific and applied photography and cinematography,
bimonthly, Mezhdunarodnaja Kniga, Moscow, G-200.

Instruments and techniques of experiments, bimonthly, Mezhdunarodnaja
Kniga, Moscow, G-200.

Young technician, monthly, Mezhdunarodnaja Kniga, Moscow, G-200.

London science teacher, quarterly, H.E. Knock, Esq.,
17, Salcombe Gardens, North Side, London, S.W. 4.

Technology, weekly, The Times, New Printing House Square, London,
E.C. 4.

American journal of physics, monthly, American Association of Physics Teachers, American Institute of Physics, 335, East 45th Street New York 17, N.Y.

Industrial research newsletter, monthly, Armour Research Foundation of Illinois, Institute of Technology, Technology Center, Chicago 16, Ill.

Science education, 5 issues per year, National Association for Research in Science Teaching, Council of Elementary Science International, C.M. Pruitt, University of Tampa, Tampa, Fla.

Sponsor's guide book, Future Scientists of America, NSTA, 1201, Sixteenth Street, N.W. Washington 6, D.C.

Education abstracts, monthly, United Nations Educational, Scientific and Cultural Organization, place de Fontenoy, 75 Paris 7e.

BBC handbook, 1963, London, British Broadcasting Corporation.

Communications media in tropical Africa., Argo G. Huth, The International Co-operation Administration, Washington D.C.

U.S.S.R. today and tomorrow, Foreign Languages Publishing House, Moscow.

Adult education groups and audio-visual techniques, 1958, United Nations Educational, Scientific and Cultural Organisation, place de Fontenoy, 75 Paris 7e.

The kinescope and adult education, 1958, United Nations Educational, Scientific and Cultural Organisation, place de Fontenoy, 75 Paris 7e.

Mass media and national development, Unesco-Stanford University Press, 1964.

Der mathematische Unterricht für die 16-21 jährige Jugend in der Bundesrepublik Deutschland, Vandenhoeck and Ruprecht.

Geometria intuitiva, La Nuova Italia, Florence.

Mathematics in the Primary School, Macmillan, London.

Multicolor Problems, Heath; Harrap, London.

Modern Mathematics with Numbers in Colour, Reading, Educational Explorers.

L'enseignement des mathematiques, 3 vols., Neuchatel: Delachaux and Nestle.

Sbornik zadac moskovskih matematiceskih olimpiad, Moscow, Prosvesceniija.

A new Approach, 5 vols. with teachers' guides, Chatto & Windus.

New Thinking in School Mathematics, Organisation for Economic Co-operation and Development.

Synopses for Modern Secondary School Mathematics, Organisation for Economic Co-operation and Development.

Premiers elements de mathematique moderne. Notes de cours redigees a l'intention des eleves des ecoles normales gardiennes, Brussels: Presses Universitaires.

How to Solve It: A New Aspect of Mathematical Method, Doubleday.

Facts to Discover and Learn, Blackwell.

How to Read Statistics, Harrap.

Teaching with Tape, Graham Jones, Focal Press, London.

Film in Higher Education and Research, P.D. Groves, Pergamon, London, 33 Queen Anne Street, W. 1.

A Guide to the 8mm. Loop Film, G.H. Powell, BACIE.

Educational Research in Britain, H.J. Butcher, ULP.

Map of Educational Research, R.H. Thouless, NFER.

Besser Verstehen - durch Hören and Sehen, WBGW, Wien 1, Hoher Markt 3.

International Review, Pergamon Press Ltd., London, 33, Queen Anne Street, W. 1.

Ton und Band, Organchemie, 1130 Vienna.

An Introduction to Visual Aids, The Visual Aids Centre,
78, High Holborn, London, W.C. 1.

Management Communication through Audio Visual Aids, Leonhard
Hill, London.

Leichter Lernen durch Bild und Ton, Norddeutsche Verlagsanstalt
Frankfurt/Main.

Making Posters: a How to do it Book, Studio Vista, London.

Visual Education Year Book, National Committee for Audio
Visual Aids, London.

Classroom Display Material, NCAVAE, London, 33 Queen Anne Street,

The Overhead Projector, NCAVAE, London, 33 Queen Anne Street,

Audiovisual Aids and Techniques in Managerial and Supervisory
Training. Hamish Hamilton, London.

Selected list of Documents and Publications on Industrial Information

A Working Approach toward a World System Effecting the Flow of Technical Information for Development, United Nations, 1966.

Arrangements for the Dissemination of Information on Industrial Technology, Centre for Industrial Development, 1964.

Institutions for Industrial Development. Dissemination of Information on Industrial Research, Centre for Industrial Development; 1966.

Industrial Research and Development News, United Nations Industrial Development Organisation, P. O. Box 111, Vienna.

UNIDO Newsletter, United Nations Industrial Development Organisation, P. O. Box 111, Vienna.

Technical Information Services for Industry, United Nations Industrial Development Organisation, 1967.

Exchange of Scientific Abstracts of Documents relating to Applied Economics, Economic Commission for Europe, 1966 & 1967.

Inventory of Abstracting Services in the Field of Applied Economics in the Countries of the Economic Commission of Europe, Economic Commission for Europe, 1966

World Guide to Science Information and Documentation Services, United Nations Educational, Scientific and Cultural Organisation, 1965.

Joint Project on the Communication of Scientific Information, United Nations Educational, Scientific and Cultural Organisation, 1969.

OTHER SOURCES

- Annual Review of Information Science and Technology*, Inter-Science, New York, 1966.
- Association of Special Libraries and Information Bureaux, *ASLIB Directory, Vol. 1, Information Sources in Science, Technology and Commerce*, London, 1968.
- Bakewell, K. G. B., *Industrial Libraries throughout the World*, Pergamon, London, 1969.
- Bourne, C., *Methods of Information Handling*, Wiley, New York, 1963.
- CIBA Foundation, *Symposium on Communication in Science: Documentation and Automation*, London, 1967.
- Central Statistical Office, *Standard Industrial Classification*, 3rd ed., Her Majesty's Stationery Office, London, 1968.
- Colinene, P. E., "Keeping in Touch with the Needs of Information Users", in *Proceedings of the Second Conference of the Institute of Information Scientists*, Oxford, 1966.
- David, A., "L'information dans le domaine de l'énergie en France", *Bulletin des Bibliothèques de France* Vol. 13 (1968), No. 9/10, pp. 397-416.
- Engineers Joint Council, *Information Handling Systems and Technical Information Flow*, report, New York, 1962.
- Europäische Wirtschaftsgemeinschaft, *Informationsquellen wichtiger Daten für die Unternehmensführung*, 2nd ed., Brussels, 1967.
- European Research Index: a Guide to Scientific and Industrial Research in Western Europe*, Vol. 2, Francis Hodgson Ltd., Guernsey, 1965.
- Giles, C. G., The materialization of Scientific Research Results in British Industry, paper prepared for the Symposium on Communication of Scientific and Technical Information to Industry, held in Rome in October 1969, F11, The Hague (document C. 23 (18)) (mimeo.).
- International Federation for Documentation, *Availability of Scientific Conference Papers and Proceedings*, Paris, 1962, and 1966.
- International Federation for Documentation, *National Technical Information Services*, world-wide directory, The Hague, 1966.
- International Science and Technology* "Should Science Information be Centralized or Decentralized", June 1964, pp. 100-104.
- Julius, H. W., "Research Organization TNO Serves Dutch Community", *Industrial Research and Development News* Vol. 2 (1968), No. 2, pp. 28-33.
- Keegan, W. J., "How and Where Do Executives Acquire Important Business Information?" *Incentive*, No. 11 (August 1968), pp. 11-13.
- Kent, A., *Specialized Information Centres*, Spartan Books, Washington, D.C., 1965.
- Klintos, K., Report to the OECD Scientific and Technical Information Policy Group, Paris, 1968 (mimeo.).
- Little, A. D. Inc., *The JR's Program, Meeting Industry's Information Needs*, New York, 1967.
- Martindale, E., "Industrial Liaison Centre: A New Approach to the Problem of Encouraging Technical Innovation in the Smaller Firm", *Bulletin of the Institute of Information Scientists*, No. 5 (1966), pp. 3-10.
- Melik-Shakhnasarov, A. S., *Nauchno-tekhnicheskaya informatsiya i propaganda v mashinostroenii*, Gosudarstvennoe Nauchno-Tekhnicheskoe Izdatelstvo Mashinostroitelnoi Literatury, Moscow, 1960.
- Meltzer, H. F., *The Information Center: Management's Hidden Interest*, American Management Association, New York, 1967.
- Mikhailov, A. I., A. I. Taberny and R. S. Gilyarevsky, *Fundamentals of Scientific Information*, 2nd ed., Nauka, Moscow, 1968 (in Russian).

- Ministry of Technology - U.K. *Technical Service for Industry*, Technical Information and Other Services Available from Government Departments and Associated Organizations, Her Majesty's Stationery Office, London, 1968.
- Moh, M. *Transmission d'informations scientifiques et techniques, état et tendances du développement*, Jugoslovenski Centar za Tehnicku i Navenu Dokumentaciju, Belgrade, 1967.
- OECD, *Conference on the Communication of Scientific and Technical Knowledge to Industry*, held in Stockholm in October 1963, Paris, 1965.
- Paepis, C. and J. P. Poupko, "Une expérience d'information chimique", *Industrie Chimique Belge* Vol. 33 (1968), No. 10, pp. 866—868.
- Parliamentary and Scientific Committee, *Report on Collection, Dissemination, Storage and Retrieval of Scientific and Technological Information*, Carey, London, 1968.
- Rippon, J. S., *The Industrial Information Specialist as a Mediator in the Information Transfer Process*, paper prepared for the Symposium on Communication of Scientific and Technical Information to Industry, held in Rome in October 1969, FID, The Hague (document A 3 (13)) (mimeo.).
- Rosenbloom, S. and W. Wolek, *Technology, Information, and Organization*, Information Transfer in Industrial R & D, National Science Foundation, Boston, 1967.
- Royal Institute of British Architects, *The Organisation of Information in the Construction Industry*, RIBA, London, 1968.
- Rutgers State University, *Bibliography of Research relating to the Communication of Scientific and Technical Information*, Rutgers University Press, New Brunswick, N. J., 1967.
- Schur, H. et al., *Education and Training for Scientific and Technological Library and Information Work*, Her Majesty's Stationery Office, London, 1968.
- Science Council of Canada, *Scientific and Technical Information in Canada*, Part I, Ottawa, 1969.
- Science, Government and Information: the Responsibility of the Technical Community and the Government in the Transfer of Information*, report of the President's Science Advisory Committee, Government Printing Office, Washington, D. C., 1963.
- Snow, D. C., "Technical Information from Patents", *Metals and Materials*, Vol. 2 (1968), No. 12, pp. 353—358.
- Strain, P. M., "The Industrial Librarian as Cooperator", *Special Libraries*, Vol. 40 (1969), No. 4, pp. 209—214.
- Van Houten, R., "Scientific and Technical Information for Industry", paper prepared for the Symposium on Communication of Scientific and Technical Information to Industry, held in Rome in October 1969, FID, The Hague (document C. 0 (12) and C. 0 (26)) (mimeo.).
- Wellisch, H., *An International Centre for Standards Documentation*, Society of Special Libraries and Information Centres, Tel Aviv, 1969.
- Wood, D. and D. R. L. Hamilton, *The Information Requirements of Mechanical Engineers, Report of a Recent Survey*, Library Association, London, 1967.

B. National distributions of United Nations publications and other books

- ALBANIA:** N. Sh. Botimeve Naim Prasheri, TIRANA.
- ALGERIA:** Institut pédagogique national, 11, rue Ali-Haddad (ex-rue Zaïcha), ALGER; Société nationale d'éducation et de diffusion (SNED), 1, boulevard Zirout Youcef, ALGER.
- ARAB REPUBLIC OF EGYPT:** Librairie Kasse El Nil, 38, rue Kasse El Nil, LE CAIRE; National Centre for Unesco Publications, 1, Talat Harb Street, Librairie Soudani, CAIRO.
- ARGENTINA:** Editorial Losada, S.A., Alsina 1141, BUENOS AIRES.
- AUSTRALIA:** Publications Educational Supply Pty Ltd., Box 11, Post Office, Brookvale 2100, N.S.W. *Permanent Display:* Dominion Pty Ltd., Box 11, Post Office, Brookvale 2100, N.S.W. *Sub-agent:* United Nations Association of Australia, Victorian Division, 575 Essex, 124-125 Elmford Street, MELBOURNE 3000.
- AUSTRIA:** Verlag Georg Fromme & Co., Arbergasse 11, 1070 WIEN.
- BELGIUM:** Jean De Lannoy, 112, rue du Prince, BRUXELLES, C.P. 20822.
- BOLIVIA:** Librería Universitaria, Universidad San Francisco Xavier, apartado 112, SUCRE.
- BRAZIL:** Fundação Getúlio Vargas, Serviço de Publicações, caixa postal 21120, Praia de Botafogo 195, RJ, DE JANEIRO, GB.
- BULGARIA:** Hémus, Kantora Literaturna, Bd. Rouben 6, SOFIA.
- BERMA:** Trade Corporation (No. 10), 550-552, Merchant Street, RANGOON.
- CAMEROON:** Le Secrétaire général de la Commission nationale de la République fédérale du Cameroun pour l'Unesco, B.P. 1061, YAOUNDÉ.
- CANADA:** Information Canada, OTTAWA (Ont.) Bookshop, 640 Rue L. rue Sainte-Catherine, MONTRÉAL III, Qué., 1683 Barrington St., HALIFAX (N.S.), 303 Portage Ave., WINNIPEG (Manitoba), 171, rue Slater, OTTAWA (Ont.), 221 Jonge St., TORONTO (Ont.), 805 Granville St., VANCOUVER (B.C.).
- CHILE:** Editorial Universitaria S.A., Casilla 10220, SANTIAGO.
- COLOMBIA:** Librería Buchholz Galería, avenida Jiménez de Quesada B-40, apartado aéreo 49-46, BOGOTÁ; Distribibros Ltda., Pío Alfonso García, carrera 4ª, n.º 36-119 y 36-145, CARTAGENA; J. Germán Rodríguez N., calle 17, 6-59, apartado nacional 83, GIRARDOT (Cundinamarca); Editorial Losada Ltda., calle 18A, n.º 7-37, apartado aéreo 5829, apartado nacional 911, BOGOTÁ; *Sub-depot:* Edificio La Ceiba, Oficina 804, MEDELLÍN; Calle 37, n.º 14-73, Oficina 305, BUCARAMANGA; Edificio Zaccour, Oficina 736, CALI.
- CONGO (People's Republic of the):** Librairie populaire, B.P. 577, BRAZZAVILLE.
- COSTA RICA:** Librería Trejos, S.A., apartado 1000, SAN JOSÉ. Teléfonos 2285 y 3200.
- CUBA:** Distribuidora Nacional de Publicaciones, Neptuno 674, LA HABANA.
- CYPRUS:** 'MAM', Archbishop Makarios 3rd Avenue, P.O.B. 1723, NICOSIA.
- CZECHOSLOVAKIA:** SNTL, Spalena 51, PRAHA 1 (*Permanent display*); Zahraniční literatura, 11 Soukenicka, PRAHA 1. *For Slovakia only:* Alfa Verlag, Publishers, Hurbanovo nám. 6, 893 31 BRATISLAVA.
- DANOMBY:** Librairie nationale, B.P. 294, PORTO NOVO.
- DENMARK:** Ejnar Munksgaard Ltd., 6, Nørregade, 1165, KØBENHAVN K.
- DOMINICAN REPUBLIC:** Librería Dominicana, Mercedes 40, apartado de correos 656, SANTO DOMINGO.
- ECUADOR:** Casa de la Cultura Ecuatoriana, Nucleo de Guayas, P.O. Box Moncayo y 9 de Octubre, casilla de correo 3542, GUAYABUIL.
- EL SALVADOR:** Librería Cultural Salvadoreña, S.A., Edificio San Marino, 6ª calle Oriente 67, 118, SAN SALVADOR.
- ETHIOPIA:** National Commission for Unesco, P.O. Box 2906, ADDIS ABABA.
- FINLAND:** Akateeminen Kirjakauppa, 2, Keskus, HELSINKI.
- FRANCE:** Librairie de l'Unesco, place de Fontenay, 75006 Paris, C.C.P. 12508-48.
- FRENCH WEST INDIAN:** Librairie 'Au Boul' Mich', 1, rue Perronnet and 66, avenue du Parquet, 972 FORT-DE-FRANCE (Martinique).
- GERMAN DEMOCRATIC REPUBLIC:** Deutscher Buch-Export und Import GmbH, Lenninstrasse 16, 101 11 PEIPZIG.
- GERMANY (FED. REP.):** Verlag Dokumentation, Postfach 148, Jägerstrasse 11, 8023 MÜNCHEN-PRITZLAR. *For The GDR only:* Bahnenleiter, Chaussee 16, HAMBURG-BAHNDORF. C.C.P. 22 05 25. *For scientific books only:* GIZ Center, D7 STUTTGART 80, Postfach 10 83.
- GHANA:** Presbyterian Bookshop Depot Ltd., P.O. Box 195, ACCRA; Ghana Book Suppliers Ltd., P.O. Box 7860, ACCRA; The University Bookshop of Ghana, ACCRA; The University Bookshop, CAPE COAST; The University Bookshop, P.O. Box 1, LEGGOS.
- GREECE:** Anglo-Hellenic Agency, 5, Koumpouriotou, ATHINA 115.
- GUATEMALA:** Comisión Nacional de la Unesco, 6ª calle 9-27, ZONA 1, GUATEMALA.
- HAITI:** Librairie 'A la Caravelle', 36, rue de la République, PORT-AU-PRINCE.
- HONG KONG:** Swindon Book Co., 111-113, Lock Road, KOWLOON.
- HUNGARY:** Akadémiai Kiadóvkiadó, Váci u. 22, BUDAPEST; V. A. K. V. Könyvtársaság, József köz, 1053, BUDAPEST VI.
- IRELAND:** Snaechóirn Josselyn & Co., P.E. Hafnarstra, KEYSIAUX.
- INDIA:** Orient Longman Ltd., Nicol Road, Ballard Estate, BOMBAY 11; 17, Christianian Ave., CALCUTTA 11; 11, Anna Salas, Mount Road, MADRAS 21; B-117, Anna Road, NEW DELHI. *Sub-depot:* Oxford Book and Stationery Co., 19 Park Street, CALCUTTA 16, and Scindia House, New Delhi; Publications Section, Ministry of Education and Social Welfare, 72 Theatre Communications Building, 72, Connaught Place, NEW DELHI.
- INDONESIA:** Indira P.T., Jl. Dr. Sam Ratulangi 100, JAKARTA.
- IRAN:** Commission nationale iranienne pour l'Unesco, avenue Iranchahr Chomali n.º 310, B.P. 1533, TEHRAN; Kharazmie Publishing and Distribution Co., 11, Daneshgah Street, Shah Avenue, P.O. Box 1486, TEHRAN.

- IRAQ:** McKenzie's Bookshop, Al-Rashid Street, BAGHDAD; University Bookstore, University of Baghdad, P.O. Box 75, BAGHDAD.
- IRELAND:** The National Press, 2 Wellington Road, Ballsbridge, DUBLIN 4.
- ISRAEL:** Emanuel Brown, formerly Blumstein's Book Stores, 15 Allenby Road, and 48 Nachlat Benjamin Street; TEL AVIV, 9 Shlomzion Hamalka Street, JERUSALEM.
- ITALY:** LICUSA Libreria Commissionaria Sansoni S.p.A., via Lamarmora 45, casella postale 552, 50121 FIRENZE.
- IVORY COAST:** Centre d'édition et de diffusion africaines, Boite postale 4541, ABIDJAN PLATEAU.
- JAMAICA:** Sangster's Book Stores Ltd., P.O. Box 366, 101 Water Lane, KINGSTON.
- JAPAN:** Maruzen Co. Ltd., P.O. Box 5050, Tokyo International, TOKYO.
- KENYA:** The ESA Ltd., P.O. Box 30167, NAIROBI.
- KHMER REPUBLIC:** Librairie Albert Portail, 14, avenue Boukhehe, PHNOM PENH.
- KOREA:** Korean National Commission for Unesco, P.O. Box 64, SEOUL.
- KUWAIT:** The Kuwait Bookshop Co. Ltd., P.O. Box 2942, KUWAIT.
- LIBRANON:** Librairies Antoine, A. Nautal et frères, B.P. 656, BEYROUTH.
- LIBERIA:** Cole & Yancy Bookshops Ltd., P.O. Box 286, MONROVIA.
- LIBYA:** Agency for Development of Publication and Distribution, P.O. Box 34-35, TRIPOLI.
- LICHTENSTEIN:** Eurocan Trust Reg., P.O.B. 5, SCHAAN.
- LUXEMBOURG:** Librairie Paul Bruck, 22, Grand-Rue, LUXEMBOURG.
- MADAGASCAR:** *All publications:* Commission nationale de la République malgache, Ministère de l'éducation nationale, TANANARIVE.
- MALAYSIA:** Federal Publications Sdn Bhd., Balai Berita, 31 Jalan Riong, KUALA LUMPUR.
- MALI:** Librairie populaire du Mali, B.P. 28, BAMAKO.
- MALTA:** Sapiezza's Library, 26 Kingsway, VALLETTA.
- MAURITIUS:** Nalanda Co. Ltd., 30 Bourbon Street, PORT-LOUIS.
- MEXICO:** CILA Centro Interamericano de Libros Académicos, Sullivan 31 bis, MÉXICO 4, DF.
- MOROCCO:** British Library, 30, boulevard des Moulins, MONTE-CARLO.
- MOROCCO:** *All publications:* Librairie 'Aux belles images', 281, avenue Mohammed V, RABAT (CCP 68-74); *For 'The Courier' for teachers: only:* Commission nationale marocaine pour l'Unesco, 20, Zenkat Mourabidine, RABAT (CCP 307-63).
- MOZAMBIQUE:** Salama and Carvalho Ltda., caixa postal 192, BEIRA.
- NETHERLANDS:** N.V. Martinus Nijhoff, Lange Voorhout 9, 3-GRAVENHAGE; System Keesing, Ruysdelastraat 71-75, AMSTERDAM.
- NETHERLANDS ANTILLES:** G. C. T. Van Dorp and Co. Ned. Ant. N.V., WILLEMSTAD (Curaçao, N.A.).
- NEW CALEDONIA:** Représ S.A.R.L., B.P. 1572, NOUMEA.
- NEW ZEALAND:** Government Printing Office, Government Bookshops, Rutland Street P.O. Box 5344, AUCKLAND, 130 Oxford Terrace, P.O. Box 1731, CHRISTCHURCH, Alma Street, P.O. Box 857, HAMILTON; Princes Street, P.O. Box 1104, DUNEDIN, Mulgrave Street, Private Bags, WELLINGTON.
- NICARAGUA:** Libreria Cultural Nicaragüense, calle 15 de Septiembre y avenida Bolívar, apartado # 807, MANAGUA.
- NIGER:** Librairie Manguet, B.P. 658, NIAMEY.
- NIGERIA:** The University Bookshop, IFE, The University Bookshop, Ibadan, P.O. Box 286, IBADAN, The University Bookshop, NSUKKA, The University Bookshop, ILESHA, The Ahmadu Bello University Bookshop, ZARIA.
- NORWAY:** *All publications:* Johan Grundt Tanum, Karl Johans gate 41-43, OSLO 1; *For 'The Courier' only:* N.S. Narvesens Litteraturlinje, Box 8125, OSLO 8.
- PAKISTAN:** The West-Pak Publishing Co. Ltd., Unesco Publications House, P.O. Box 174, G.P.O., LAHORE; SIKANDRABAD Urdu Bazaar, LAHORE, and S-5-58 Murree Highway, S-5-1, ISLAMABAD; Pakistan Publications Bookshop, Sarwar Road, RAWALPINDI; Meeza Book Agency, 65 Shalimar Quaid-e-Azam, P.O. Box 722, LAHORE.
- PARAGUAY:** MICHIEL GARCIA, Edglo Ayala 1655, ASUNCION.
- PERU:** *For 'The Courier' only:* Editorial Losada Peruana, apartado 472, LIMA; *Other publications:* Distribuidora Lucas A. Lemire Alvaraz 470, Lima, casilla 3115 LIMA.
- PHILIPPINES:** The Modern Book Co., 926 Rizal Avenue, P.O. Box 612, MANILA.
- POLAND:** Ośrodek Rozwojotechniczny Wydawnictw Naukowych PAN, Pałac Kultury i Nauki, WARSZAWA.
- PORTUGAL:** José A. André de Lida, Livraria Portugal, rua do Carmo 50, LISBOA.
- SOUTHERN AFRICA:** Textbook Sales (P.V.) Ltd., 67 Union Avenue, NATALBERG.
- ROMANIA:** C.P. LIBRI, Calea Victoriei no. 126, P.O. B. 134-145, BUCUREȘTI; *Subscriptions to periodicals:* Romproeditiana, Calea Victoriei no. 29, BUCUREȘTI.
- SENEGAL:** La Maison du Livre, 13, avenue Roume, B.P. 2060, DAKAR; Librairie Clairatque, B.P. 2005, DAKAR; Librairie 'Le Sénégal', B.P. 1694, DAKAR.
- SINGAPORE:** Federal Publications Sdn Bhd., Times House, River Valley Road, SINGAPORE 9.
- SOUTH AFRICA:** Van Schaik's Bookstore (Pty.) Ltd., Libri Building, Church Street, P.O. Box 724, PRETORIA.
- SPAIN:** *All publications:* Ediciones Interamericanas, S.A., calle de Oñate 15, MADRID 20; *Distribucion de Publicaciones del Consejo Superior de Investigaciones Cientificas:* Vitrubio 16, MADRID 6; *Libreria del Consejo Superior de Investigaciones Cientificas Egipcíacas:* 15, BARCELONA; *For 'The Courier' only:* Ediciones Liber, apartado 17, ONDARROA, Vizcaya.
- SRI LANKA:** Lake House Bookshop, Sir Chittampalam Gardiner Mawata, P.O. Box 244, COLOMBO 2.
- SUDAN:** Al-Bashir Bookshop, P.O. Box 1118, KHARTOUM.
- SWEDEN:** *All publications:* A.B.C. E. Fritzes Kungl. Hovbokhandel, Fredsgatan 2, Box 16356, 103 27 STOCKHOLM 16; *For 'The Courier' only:* Svenska FN-Förbundet, Skolgränd 2, Box 150 50, S-104 65 STOCKHOLM.
- SWITZERLAND:** Europa Verlag, Ramistrasse 5, ZÜRICH; Librairie Payot, 6, rue Grenus, 1211, GENÈVE 11.
- SYRIA:** Librairie Sayegh, Immeuble Diab, rue du Parlement, B.P. 704, DAMAS.
- TANZANIA:** Dar es Salaam Bookshop, P.O. Box 9030, DAR ES SALAAM.

THAILAND: Suksepan Panit, Mansion, 9, Rajdamnern Avenue, BANGKOK

TOGO: Librairie évangélique, B.P. 198, LOMÉ, Librairie du Non Pasteur, B.P. 1164, LOMÉ, Librairie moderne, B.P. 777, LOMÉ

TUNISIA: Société tunisienne de diffusion, 5, avenue de Carthage, TUNIS

TURKEY: Librairie Hachette, 469 Istanbul Cadden, Beyoglu, ISTANBUL

UGANDA: Uganda Bookshop, P.O. Box 145, KAMPALA

UNITED KINGDOM: H.M. Stationery Office, P.O. Box 469, LONDON SE1 9NH. Government bookshops: London, Belfast, Birmingham, Liverpool, Cardiff, Edinburgh, Manchester.

UNITED STATES OF AMERICA: Unesco Publications Center, P.O. Box 433, New York, N.Y. 10016.

UPPER VOLTA: Librairie Atlas, B.P. 64, OUAGADOUGOU. Librairie catholique "Jeunesse d'Afrique", OUAGADOUGOU

URUGUAY: Editorial Losada Uruguay, S.A. Libreria Losada, Maldonado 1902 Colonia 1340, MONTEVIDEO

U.S.S.R.: Mezhdunarodnaja Kniga, MOSCOW G 200

VENEZUELA: Libreria Historia, Momias a Padre Sierra, Edificio Oeste 2, n.º 6 (frente al Capitolio), apartado de correos 7320-101, CARACAS

VIENTIANE (REPUBLIC OF): Librairie papeterie Xuan-Lhu, 190-193, rue Tu-Dao, B.P. 283, SAIGON

YUGOSLAVIA: Jugoslovenska Knjiga, Terazije 27, BEOGRAD. Drzavna Zalozba Slovenije, Mestni Trg 26, LJUBLJANA

REPUBLIC OF ZAIRE: La Librairie, Institut national d'études politiques, B.P. 2307, KINSHASA, Commission nationale de la République du Zaïre pour l'Unesco, Ministère de l'éducation nationale, KINSHASA.

INSTITUTIONS AND ORGANISATIONS

INTERNATIONAL UNION OF CINEMATOGRA- PHIC TECHNICAL ASSOCIATIONS (UNIATEC): NATIONAL MEMBERS

The UNIATEC was constituted in 1957 at the Third International Congress on Film Techniques in Warsaw, its aims being defined as (1) to develop the corporate spirit and co-operation among its members, (2) to encourage international co-operation in film techniques by the exchange of information and, more particularly, by the organizing of International Colloquys and by reciprocal visit of technicians from the various countries, (3) to encourage the setting-up of national associations of film technicians in the countries where these do not yet exist, (4) to encourage studies for the advancement of film techniques, and to support any efforts undertaken in the direction of standardization.

The Union is open to all associations (or specialized sections of associations) of film technicians whose aims are confined to work and discussion of a technical nature.

Secretariat: 92 Champs-Elysées, 75008 Paris, France.

The information given hereafter is in the form supplied by UNIATEC.

BELGIUM

Commission supérieure technique belge - Cinéma-
tèque de Belgique (Siège social) 23 rue Ravenstein,
Bruxelles 1, (adresse correspondance to): Labora-
toire Daseonville, 135 rue Barthélot, Bruxelles 19.

BULGARIA

Institute for Scientific Research in Cinematography
and Radio, 2 rue Budapest, Sofia.

CANADA

National Film Board, P.O. Box 6100, Montreal 3,
Quebec.

CZECHOSLOVAKIA

Ústřední ředitelství Českého filmu, Jindřišská 34
Praha 2

Výzkumný ústav zvukové, obrazové a reprodukční
techniky (V. U. Z. O. R. T.), Pilsenská 66, Praha 5
(Smíchov)

Interkamera - Centre for International Co-operation
in the Field of Audio-Visual Engineering and
Art, Konvitská 5, Praha 1

DENMARK

Den Danske Sektion Nordisk Film og Ujersyns-
tion, Statens Filmcentral Vestergade 27, København K

FRANCE

Commission supérieure technique (C. S. T.), 92
Champs-Elysées, Paris 8

GERMANY (Democratic Republic)

Wissenschaftlich-technischer Beirat des Filmwesens
der DDR, DEFA Zentralstelle für Filmtechnik,
Gross-Berliner Damm 61, 1197 Berlin Johannisthal

HUNGARY

Optikai Akusztikai és Filmtchnikai Egyesület, VI
Ankerkőz 1, Budapest

ITALY

Associazione tecnica Italiana per la cinematografia
(A. T. I. C.), Viale Regina Margherita 286, Roma

KOREA (People's Republic)

Union of Korean Film-Makers, Pyong-Yang

MEXICO

Sindicato de Trabajadores Tecnicos y Manuales de
Estudios y Laboratorios de la Produccion Cinema-
tografica, Versailles Num. 27, Mexico 6 - D. F.

POLAND

Filmowy Ośrodek Dosciadczalno Usługowy (F. O. D. U.),
Ul. Dominikanska 9, Warszawa 25

ROMANIA

Asociatia Cineastilor din Republica Populara Ro-
mina (A. C. I. N.), Str. Gheorghe Gheorgiu Daj 63,
Bucarest 1

SWEDEN

Svenska Filminstitutet, Borgvägen 1 - Box 27126,
10252 Stockholm

TUNISIA

Association des cinéastes tunisiens, c/o Maison
de la Culture, 16 rue Ibn Khaldoun, Tunis

UNION OF SOVIET SOCIALIST REPUBLICS

Union of Soviet Filmmakers, "Science and Techni-
que" Section, 13 Vassilievskaja Street, Moscow

Nauchno Isledovatel'sky Kino Foto Institut
(N.I.K.F.I.) Leningradski Prospect 47, Moscow

**UNITED KINGDOM OF GREAT BRITAIN
AND NORTHERN IRELAND**

**Cinematograph Exhibitors' Association of Great
Britain and Ireland, 22-25 Dean Street, London
W. 1**

**British Kinematograph, Sound and Television So-
ciety (B. K. S. T. S.), 119-112 Victoria House,
Varnon Place, London, W. C. 1**

UNITED STATES OF AMERICA

**Society of Motion Picture and Television Engineers
(S. M. P. T. E.), 9 East 41st Street, New York, N. Y.,
10017**

YUGOSLAVIA

Jugoslavija Film, Knez Mihailova 19, Beograd

International Council for Educational
Media (ICEM) National Branches

The Council was founded in 1950 under the name of the International Council for Educational Films, in order to cope with the wide range of educational media for which its national organizations were responsible. The name was changed in 1966 to the International Council for the Advancement of Audio-visual Media in Education, and in 1970 to its present title. Full membership is open to one person from each country competent to represent the national organization for production, distribution and use and/or information on modern media for education. The objectives of ICEM include: to promote world-wide contacts, to provide an international channel for an exchange of views and experience in the field of educational technology, and to promote a better integration and use of all modern media in education.

Secretariat: 29 rue d'Ulm, 75 - Paris 5.

ARGENTINA

Mrs. E. Sanchez de Mendez, Departamento de Tecnologia Educativa, Ministerio de Educacion, Lavalle 2634 - 2o Piso - Buenos Aires.

AUSTRALIA

Mr. D. W. Hood, Education Liaison Officer, Canberra House, Maitland Street, Strand, London WC 2 R 3EH, England.

AUSTRIA

Dr. F. Hubalek, Bundesstaatliche Hauptstelle für Lichtbild und Bildungsfilm (S. H. B.), Seneengasse 3, A 1090 Wien 9.

BELGIUM

Mr. J. Sauwen, Service cinématographique, Ministère de l'éducation et de la culture française, 7 quai du Commerce, 1000 Bruxelles.

Mr. E. Hambrouck, Service cinématographique, Ministère de l'éducation et de la culture flamande, 7 quai du Commerce, 1000 Bruxelles.

CANADA

Mr. W. Jobbins, National Film Board of Canada, 1 Grosvenor Square, London W1X 0AB, England.

DAHOMEY

Mr. C. Prince-Abodjan, Service des moyens audiovisuels, Ministère de l'éducation nationale, Porto Novo.

DENMARK

Mr. A. Jepsen, Statens Filmcentral, Vestergade 27, 1456 Copenhagen K.

FINLAND

Miss V. Toivone, Valtion Opetus- ja Kuvatuonnuskeskus, Boulevardi 17 A 14, 00120 Helsinki 12.

FRANCE

Mr. R. Lefranc, Office français des techniques modernes d'éducation (OFRA FEME), 29 rue d'Ulm, 75 - Paris 5.

FEDERAL REPUBLIC OF GERMANY

Dr. W. Cappel, Institut für Film und Bild in Wissenschaft (F.W.U.), Bavaria - Film-Platz 3, 8022 Grunwald, b. Munich.

DEMOCRATIC REPUBLIC OF GERMANY

Deutsches pädagogisches Zentralinstitut, Krausenstrasse 8, 108 Berlin.

GHANA

Mr. Nyatepe-Co, Ghana National Audiovisual Centre, Ministry of Information, P.O. Box 745, Accra.

GUATEMALA

Mr. A. Matute, Audiovisual Centre of the University of San Carlos, Ciudad Universitaria, Zona 12, Guatemala.

HUNGARY

Mr. J. Dues, Committee for Audio-Visual Media, Martinelli Ter 8, Budapest V.

JAPAN

Mr. T. Moriwski, Japan Audio-visual Educational Association (J. A. V. E. A.), 26 Nishikubo Sakuragawacho, Shiba, Minato-ku, Tokyo.

KUWAIT

Mr. Al Raahed, Audio-visual Aids Department, Ministry of Education, Kuwait.

LUXEMBOURG

Mr. E. Kohl, Centre audio-visual, Office du film scolaire, Walfardaange.

MADAGASCAR

Mr. Ramalendjoana, Ministère des Affaires culturelles, Direction générale des services académiques, Direction de l'enseignement du 1er degré, B.P. 267, Tananarive.

MEXICO

Mr. Galvez Y Fuentes, Instituto Latinoamericano de la Comunicación Educativa (ILECE), Vencesca Mexico, Apartado postal 18862, Mexico 16, D.F.

NETHERLANDS

Mr. J. H. L. Jongbloed, Nederlands Instituut voor audiovisuele media (N.I.A.M.), 1133 Sweelinckplein, Postbus 6426, The Hague 2078.

NORWAY

Mr. L. Fanavon, Statens Filmcentral, Schwaneengate 6, Oslo 1

POLAND

Mrs. Wrobel-Kobiewska, Instytut pedagogiki, U. Gorosiewska 8, Warsaw.

PORTUGAL

Mr. A. C. Leonidas, Institute for the Audio-visual Media in Education, Rue Florbela Espanca, Lisbon 5

SWEDEN

Mr. Hansson, Utbildningsförlaget, Fack S 104 22 Stockholm 22.

SWITZERLAND

Mr. R. Hartmann, Centrale du film scolaire, Erlachstrasse 21, CH 3000 Berne 9.

TUNISIA

Mr. M. Ben Ajmia, Secrétaire général de l'Institut des sciences de l'éducation, 17 rue Fénélon, Tunis.

TURKEY

Mr. K. Erden, Educational Aids and Technical Cooperation, Ministry of Education, Ankara.

UNITED KINGDOM OF GREAT BRITAIN
AND NORTHERN IRELAND

England Dr. J. A. Harrison, Educational Foundation for Visual Aids (E. F. V. A.), 33 Queen Anne Street, London W1M 0AL.

Scotland Mr. MacLuskie, Scottish Film Council, 16/17 Woodside Terrace, Glasgow C3.

UNITED STATES OF AMERICA

Dr. Anna L. Hyer, Division of Educational Technology, National Education Association, 1201 Sixteenth Street, N. W., Washington D. C. 20036.

YUGOSLAVIA

Mr. R. Jaskovjevic, Educational and Cultural Film Centre, Marsala Tita 2, Belgrade.

INTERNATIONAL SCIENTIFIC FILM ASSOCIATION

INTERNATIONAL SCIENTIFIC FILM ASSOCIATION - ISFA - NATIONAL BRANCHES

ISFA is a non-profit-making and non-governmental organization. Although all the national associations representative of the scientific film movement of various countries, it was established in 1944 at a meeting in Paris attended by representatives of many countries and of UNESCO. The Association was created in the belief, as is stated in the Preamble to its Constitution, that international co-operation in the field of science must contribute increasingly to the maintenance of peace between nations and to the well-being of mankind, and that in such co-operation the cinema has a major rôle to fill. The members of the Association are persuaded that scientific methods - research, teaching and the dissemination of scientific knowledge - in which cinematographical assists in the increase of human welfare through the application and development of science should be more earnestly and more widely pursued.

Since then, ISFA has stimulated the forming of national scientific film associations in countries of countries and developed practical procedures for furthering its main functions, which are: the freest, widest and most efficient exchange of information about production, the use and the effect of all types of scientific films; films themselves and cinematic material, the personal experience, skills and ideas of workers in scientific cinematography.

Each year, it organizes in a different country an international congress and festival where selected films are presented and specialized papers are read.

In addition, the specialized sections (research, higher education, popularization of science) hold meetings in the course of the year.

Headquarters: 38 Avenue des Terres, 75 - Paris 17.

The following information is in the form supplied by ISFA.

ARGENTINA

Investigaciones Cinematográficas de la Universidad de Buenos Aires, Peru 222, Buenos Aires. Director: Mr. Aldo-Luis Persano.

AUSTRALIA

Commonwealth Scientific and Industrial Research Organization, 314 Albert Street - P.O. Box 89, East Melbourne (Victoria) - 3002. Secretary (Administration) Mr. L.G. Wilson, Officer in Charge; Film Unit - Mr. Stanley T. Evans.

AUSTRIA

Wissenschaftliche Hauptstelle für Leihfilm und Buchleihfilm, Abteilung wissenschaftlicher Film, Schubbrunnerstrasse 56, A - 1010 Vienna. Director: Dr. Danward G. Burkert.

BELGIUM

Institut national de cinématographie scientifique, 21 rue Vautier, 1040 - Bruxelles. Director: Mr. Louis Quiliani.

BRAZIL

Instituto Nacional de Cinema, Praça da República, 247 - A - 2e andar, 10.000 - Janeiro. President: Mr. Ricardo Crave Alvim.

BULGARIA

Popular Science Films Studio, 916 Boulevard Buzov, Sofia. Director: Mr. Toncho Tchoukovassv.

CANADA

Canadian Science Film Association, c/o Mrs. J. Whitstone, Canadian Education Association, 252 Bloor Street West, Toronto - 5, Ontario.

CZECHOSLOVAKIA

Czechoslovak Scientific Film Association, at Czechoslovak Academy of Sciences, Zanradn.kova 26, Brno.

FRANCE

Institut de cinématographie scientifique, 38 Avenue des Terres, 75 - Paris 17. President: Dr. Bernard Vanancien. Director: Mr. Jean Pauluové.

FEDERAL REPUBLIC OF GERMANY

Institut für den wissenschaftlichen Film, Nonnenstieg 72, 34 - Göttingen. Director: Professor Dr. Ing. Gotthard Wolf.

DEMOCRATIC REPUBLIC OF GERMANY

Nationale Vereinigung für den wissenschaftlichen Film in der DDR, Alt Newawes 116/118, 1502 - Potsdam Babelsberg. President: Professor Wolfgang Bethmann.

HUNGARY

National Hungarian Committee, Magyar Film és Művészek Szövetsége, Gorkij Fiacs: 38, Budapest VI. President: Mr. Agoston Kollanyi.

ISRAEL

Israel Scientific Film Organization, P. O. B. 7181, Jerusalem. Chairman: Dr. E. K. Huppert.

ITALY

Associazione Italiana di Cinematografia Scientifica, Via Alfonso Barelli 50, Rome. President: Professor Alberto Stefanini.

JAPAN

The Japan Science Film Institution, 2-1-1, Surugadai Kanda, Chiyoda-ku, Tokyo. Head Director: Dr. Sanjirō Tomonaga. Executive Director: Mr. Saichirō Kanzawa.

PEOPLE'S REPUBLIC OF KOREA

Korean Scientific Film Association, Pyongyang.

NETHERLANDS

Netherlands Scientific Film Association, Hengelvoldstraat 29, Utrecht. Secretary: Dr. R. L. Schuurmans.

PHILIPPINES

The Scientific Film Association of the Philippines, c/o National Science Development Board, P. O. Box 3596, Manila. Executive Secretary: Mr. Mauro L. Gonzales.

POLAND

Polish Scientific Film Association, Al. Ujazdowska 45, Warsaw. President: Professor Jan Jacoby.

ROMANIA

Studio Cinematografic Alexandru Sahia, B-dul Aviatorilor 106, Bucharest. I. S. F. A. Delegate: Mr. Ion Bostan.

SPAIN

Asociación española de Cine científico, Patronato "Juan de la Cierva", Serrano 150, Madrid 3. President: Mr. Guillermo F. Zuniga.

UNION OF SOVIET SOCIALIST REPUBLICS

Association of Filmmakers of the USSR, Vassilievskaya 13, Moscow. President of the Board: Mr. Lev Kulidshanov.

UNITED KINGDOM OF GREAT BRITAIN AND NORTHERN IRELAND

The British Industrial and Scientific Film Association, 193/197 Regent Street, London W1R 7 WA. Director: Mr. Keith Bennett.

UNITED STATES OF AMERICA

American Science Film Association, 7726 Wisconsin Avenue, Bethesda, Maryland 20814. President: Mr. Donald A. Benjamin.

URUGUAY

Asociación Uruguaya de Cine científico, Juan de Guastalla 1525, Montevideo. President: Mr. Federico Benigno Caprio. General Secretary: Mr. Dasso Ribet.

Corresponding Members

CUBA

Professor Nicolás Cisneros, Ministerio de Educación, Dirección Nacional de Extensión Cultural, 16 - 4708, Mariano 133, Havana.

MEXICO

Mr. Claudio Gómez González, Director de la Cinematografía Mexicana, Instituto Nacional de Antropología e Historia, Departamento de Promoción y Difusión, Córdoba 45, Mexico D. F.

SWITZERLAND

Mr. René Schacher, Commission de direction pour le développement de l'information audiovisuelle, 19, Avenue d'Espèze, 1024 - Ecublens (Val).

VENEZUELA

Dr. Marcel Roche, Director of the Venezuelan Institute of Scientific Research, Ministry of Health and Social Assistance, Apartado 1827, Caracas.

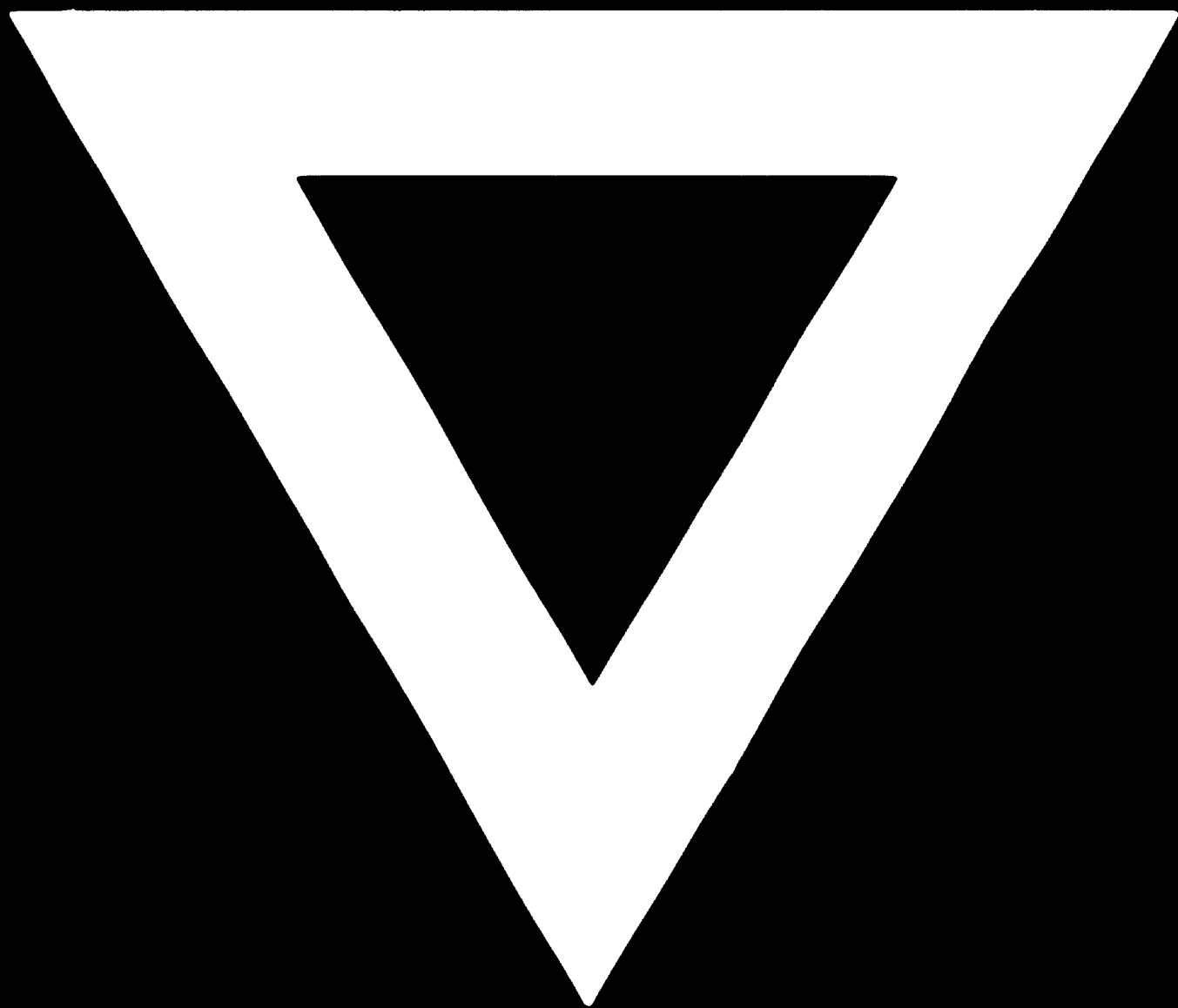

76.07.01