



TOGETHER
for a sustainable future

OCCASION

This publication has been made available to the public on the occasion of the 50th anniversary of the United Nations Industrial Development Organisation.



TOGETHER
for a sustainable future

DISCLAIMER

This document has been produced without formal United Nations editing. The designations employed and the presentation of the material in this document do not imply the expression of any opinion whatsoever on the part of the Secretariat of the United Nations Industrial Development Organization (UNIDO) concerning the legal status of any country, territory, city or area or of its authorities, or concerning the delimitation of its frontiers or boundaries, or its economic system or degree of development. Designations such as “developed”, “industrialized” and “developing” are intended for statistical convenience and do not necessarily express a judgment about the stage reached by a particular country or area in the development process. Mention of firm names or commercial products does not constitute an endorsement by UNIDO.

FAIR USE POLICY

Any part of this publication may be quoted and referenced for educational and research purposes without additional permission from UNIDO. However, those who make use of quoting and referencing this publication are requested to follow the Fair Use Policy of giving due credit to UNIDO.

CONTACT

Please contact publications@unido.org for further information concerning UNIDO publications.

Small-scale root crops and tubers processing and products

Production methods, equipment
and quality assurance practices



Copyright © 2004 by the United Nations Industrial Development Organization
Reprinted 2010

This manual was originally prepared by Mr. Peter Fellows, UNIDO Consultant, under the supervision of Mr. A. Ouaouich, PTC/AGR/FPU.

Designations employed and the presentation of material in this publication do not imply the expression of any opinion whatsoever on the part of the Secretariat of the United Nations Industrial Development Organization (UNIDO) concerning the legal status of any country, territory, city or area, or of its authorities, or concerning the delimitation of its frontiers or boundaries. The opinions, figures and estimates set forth are the responsibility of the authors and should not necessarily be considered as reflecting the views or carrying the endorsement of UNIDO. The mention of firm names or commercial products does not imply endorsement by UNIDO.

This document has not been formally edited.

Preface

UNIDO has emphasized micro/small-scale business development in its technical assistance programmes as a mean to contribute to economic growth and poverty reduction in Africa in general and Uganda in particular. This technology manual is an important tool that contributes to the capacity building activities carried out by UNIDO in the small-scale food-processing sector within the framework of the UNIDO Uganda Integrated Programme: Enhanced Competitiveness and Sustainability of Industrial Development – Agro-industries and Micro/Small-scale Enterprises.

The purpose of this manual is to guide the small-scale root crop and tuber processor in Uganda to optimize their processing methods and implement quality assurance schemes and GHP (Good Hygienic Practices) and GMP (Good Manufacturing Practices) programmes thus building their technical capacity for improved market access and competitiveness. In general, root crop processing offers good opportunities for small-scale businesses in Uganda. This is because:

- Raw materials are readily available (often in surplus - Uganda is the world's third largest producer of sweet potato).
- Equipment is affordable.
- Products are in demand both as staples for daily consumption and as snack foods.

The main types of root crops and tubers in Uganda are cassava, sweet potato and Irish potato, and to a lesser extent yam and cocoyam. Processing these root crops and tubers is intended to do two things:

1. Preserves them by slowing down the natural processes of decay caused by micro-organisms, enzymes in the roots, or other factors such as heat, moisture and sunlight.
2. Changes them into different foods that are attractive and add variety to the diet. Processors should use their skills to develop safe, attractive products that consumers want to eat. By doing this successfully, they are able to earn an income.

Although it is possible to earn a living from selling dried chips or flour made from root crops and tubers, the amount of 'added value' is limited and the volumes of crop involved are relatively high. The best types of products for profitable small-scale production are those that have a high added value as well as a good demand (especially snack foods). A high added value means that a smaller scale of processing is needed to earn a reasonable income, and the process uses smaller equipment that is more affordable. Small-scale root crop and tuber processors have many competitors in Uganda for chips and flour, as well as competing with imported snack food products. To successfully compete, it is essential to produce high quality chips and flours at competitive prices, and for snack foods to also have attractive packaging and presentation.

This technology manual covers technical aspects of root crop and tuber processing to produce safe, high quality products. It does not deal with the many other aspects of operating a successful small business (such as marketing, business and financial planning and management skills). Institutions listed in Annex A can provide more information on these topics. They are also covered by training opportunities being developed by the Uganda Cottage Scale Food Processors Association (UCOFPA) under the UNIDO Post-Harvest and Small Scale Food Processing Technologies Programme.

Hand in hand with good manufacturing, hygiene, and management practices, all partners in the food supply chain must remain aware of the expanding number of domestic and international food safety laws and regulations. Several incidences of food contamination have led the Codex Alimentarius Commission to develop additional food safety standards to enhance consumer health protection. These food safety laws, regulations and standards are mandatory. To access markets, commercial food enterprises must meet them through the application of Good Manufacturing/Hygienic Practices (GM/HP) and a Hazard Analysis and Critical Control Point (HACCP) system. The implementation of sound quality assurance programmes is also a must to increase their competitiveness

The facilities needed for commercial processing are described in Section 2. Production planning techniques and processing methods for root crops and tubers are described in Sections 3 and 4, and details of the service and maintenance requirements of processing equipment are given in Section 5. Quality assurance methods are described in Section 6. There is additional information on international and domestic food safety regulations, laws, and standards in Section 7.

How to use this manual

The information contained in this Technology Manual is intended to serve three purposes:

1. It is a resource for trainers who work with small-scale root crop and tuber processing entrepreneurs at Pilot Centres established under the UNIDO Post-Harvest and Small Scale Food Processing Technologies Programme
2. It is a reference manual to assist entrepreneurs to continue to improve the technical aspects of their businesses after training.
3. It is a reference manual that outlines practices and procedures for the production of safe, high quality root crop and tuber-based products and for development of Good Hygienic Practices (GHP) and Good Manufacturing Practices (GMP) programmes that will serve as the foundation for the preparation of a Hazard Analysis and Critical Control Point (HACCP) system.

Where appropriate, there are worked examples of calculations to assist entrepreneurs to develop their skills, particularly in production planning. Throughout the text there are also checklists of important points to enable processors to assess their present quality and food safety practices. This will assist the processors and producers to identify where production, processing, hygiene and food safety improvements are needed.

Contents

	Page
Preface	3
How to use this manual	5
Contents	6
1 Introduction to Root Crops and Tubers Processing and Products	9
<i>Checklist 1</i>	11
2 Production Facilities	13
The site	13
The building	13
Roofs and ceilings	14
Walls, windows and doors	14
Floors	15
Services	15
Lighting and Power	15
Water supply and Sanitation	15
<i>Checklist 2</i>	18
3 Production Planning	19
Raw Materials	21
Packaging	23
Equipment	23
Staff	24
Record keeping	27
<i>Checklist 3</i>	29
4 Products and Production Methods	31
Fried products	31
Dried chips	33
Flours	35
Fermented cassava/Gari	36
Dry fermentation	36
Wet fermentation	37
Gari	38
Mandazi	39
Sweet potato jam	40
<i>Checklist 4</i>	43
5 Equipment	45
Bagging equipment	48
Maintenance	50
Blanchers	50
Boiling pans and pasteurizers	50
Bottle coolers	51
Bottle washers	52
Chippers/Slicers	52
Cyclone separators	52
Deep fat fryers	53
Diesel engines	54
Dicers	55
Dryers	55
Gas burners/cylinders/regulators	57

	General tools, worktables	57
	Graters	57
	Heat sealers	58
	Hosepipes and spray guns	58
	Jam thermometers	59
	Label applicators	59
	Laboratory glassware/equipment	59
	Mills	59
	Motors/isolators/starters	65
	Peelers	65
	pH meters	65
	Pot & bottle sealers/cappers	65
	Presses	66
	Pressure cookers	66
	Protective gloves, hats, hairnets, coats, boots	66
	Refractometer	66
	Roasters	67
	Sack stitchers	67
	Maintenance	68
	Daily maintenance	69
	Weekly maintenance	69
	Scales	70
	Sulphuring cabinet	70
	Checklist 5	71
6	Quality Assurance	73
	Raw materials	74
	Processing, packing and storage	75
	Testing products and packaging	75
	Acidity	75
	Moisture content	75
	Packaging	75
	Sugar	76
	Checklist 6	77
7	Summary of Legislation and Regulation	79
	International	79
	Uganda	79
	Hygiene and sanitation	80
	Food composition	80
	Standards	81
	Additives and containments	81
	Food labelling	81
	Water	82
	Summary	82
	Checklist 7	83
	Annex A - Sources of further information and assistance	85
	Annex B - Glossary and acronyms	91

1

Introduction

Root crops and tubers are important staple foods in some parts of Uganda, where they are both eaten fresh and processed by drying to preserve them for out of season use. They are also prepared as fried snack foods and as fermented products (e.g. gari from cassava). Almost all processing is done by micro-level businesses, often based in households, and there is little medium- or large-scale processing. There is also little processing to other products such as starch, glucose syrup etc. This manual therefore focuses on processing to make chips, flours, fermented products and snack foods. At least one processor makes sweet potato jam and this product is also included. Small-scale processors are able to increase their profitability by packaging flours, or producing different flours (e.g. combinations of root crop and cereal or legume flours). The technology is available and affordable and the level of skill and expertise needed to produce high quality products is lower than in many other types of food processing. The products of root crop processing are shown in Table 1.1.

Table 1.1. Types of root crops and tubers and products in Uganda

Types of root crops and tubers	Types of products
Cassava	Chips
Coco-yam	Crisps
Irish potato	Fermented products/gari
Sweet potato	Flours
Yam	Mandazi
	Sweet potato jam

Characteristics of root crops and tubers

Root crops are moist, low acidic foods that can support the growth of food poisoning bacteria. Some types of bacteria produce poisons in the food without signs of spoilage, and consumers may therefore be unaware of the contamination and eat the poisoned food. All types of root crop processing should be carried out under hygienic conditions.

It is especially important that processors carefully follow the correct processing methods and pay strict attention to hygiene and sanitation to meet food safety standards and reduce the risk of harming their customers.

The main components of root crops and tubers are water (60-90%), starch and fibre, with lesser amounts of proteins, fats, sugars, vitamins and minerals. The outer skin is a barrier to micro-organisms and some insects, but it is easily damaged during harvest or transport, and this causes the root to spoil rapidly. The skin also slows down the loss of water from the root, preventing shrivelling and drying out for several days or weeks after harvest. However, the roots continue to mature and naturally occurring enzymes, as well as bacteria and moulds, change their colour and texture. One of the most important is an enzyme that causes rapid browning of the root crop when it is cut. Sweet potato in particular may also sprout during storage, and insects and rodents may damage all root crops and tubers. Compared to some other crops (such as cereals), there is thus a more limited amount of time available after harvest before they must be processed.

Some root crops contain toxic substances, the most important being a cyanide-containing chemical in cassava, and also a chemical named 'solanin' in some varieties of potato. In Uganda solanin is only likely to be present in potatoes that have a green discoloration, and these should not be used for processing. The cyanide-containing chemical in cassava is extremely poisonous and must be broken down by processing. The level of this poison varies in different varieties of cassava. Some people think that 'bitter' cassava contains a higher level than 'sweet' cassava, but in fact there is no strong relationship between these factors. So all cassava in Uganda should be treated as though it contains the poison.

Additional problems that face root crop and tubers processors include:

- Root crops and tubers are bulky and heavy, and therefore have high transport costs
- They have relatively low value compared to other crops
- Raw materials have to be bought during the harvest period when prices are lowest. There is therefore the need to have sufficient cash available to buy a supply of crop for processing until the next harvest.
- Most root crops and tubers are seasonal. For a business to operate throughout the year, crops must be stored, or a succession of crops must be processed as they come into season

Table 1.2. Advantages and limitations of different storage methods for root crops

Storage method	Advantages	Limitations
Leave in ground	No additional labour or storage structure required, harvest when needed	Dry season harvesting difficult, roots become fibrous, attack by pests, land cannot be used for other crops.
Pits/trenches	Protection against pests and high temperatures	Labour needed to construct pit, lack of aeration, difficult to inspect crop, not suitable for cassava (decays after a few days), other crops keep for up to 5 months in dry season.
Heaps	No structure to build, good aeration, protection against high temperatures when shaded/covered	Attack by pests, risk of theft, difficult to inspect crop at the centre, not suitable for cassava (decays after a few days)
Moist sawdust	Protects roots for up to 2 months when sawdust has correct moistness	Containers or trenches required, extra labour, need local source of sawdust
Grass clamp	For sweet potatoes, gives several months storage	Labour required, difficult to inspect crop
Polypropylene bags	Reduces weight loss, drying out and changes caused by maturing roots, especially when kept cool by shading	Cost of bags, extra labour required
Wax	Reduces weight loss, drying out and changes caused by maturing roots, especially when kept cool by shading	Cost of wax, extra labour required

Checklist 1

Can you answer these questions? Tick the box if you know the answer. Write notes on what you currently do or need to do to find the answer.

Question	Tick	Notes
1. What types of spoilage can affect your products?		
2. Do you know how long your raw materials can be stored before they begin to spoil?		
3. What are the main harvest times for your raw materials?		
4. Do you know how to handle root crops to minimise damage and spoilage?		
5. Do you save money to buy crop at harvest or manage your cash flow to make funds available for buying crop?		
6. Do you have the organisational skills to process a succession of crops throughout the year?		

2 **Production Facilities**

This section summarises the facilities needed by small-scale root crop and tuber processors.

The Site

Root crop and tuber processing units are usually located in rural areas because:

- They are close to the source of raw materials.
- Processing removes water and the products have a lower weight, so it is cheaper for processors to transport the products than to transport the fresh crops.
- Where processors sell their products in local rural markets the unit is located close to their customers.
- There is more space for disposal of wastes.
- Although electricity may not be available in rural areas, processing does not depend on electrically powered equipment.

However, there are substantial amounts of solid wastes and starchy wastewater produced by root crop processing, and it is essential that these be properly disposed of to prevent pollution of local water supplies.

The location of the processing unit in a rural area means that there may be problems with:

- Adequate supplies of potable water.
- Access for workers and staff (public transport, distance down an access road), quality of the road
- Absence of other facilities (e.g. Schools, medical facilities, shops and entertainment) that make working there less attractive than an urban location
- Insects and birds or straying animals getting into the building. It is important to have a site with cleared and fenced land, preferably having short grass, which helps to trap airborne dust.

Each of these factors should be assessed before choosing a site for the processing unit.

The building

Buildings in rural areas may cost more to construct because of higher transport costs for building materials, but rents in rural areas are usually lower than urban centres. The investment in construction or the amount of rent paid should be appropriate to the size and expected profitability of the business. The processing unit should be hygienically designed and easily cleaned to prevent contamination of products by insects, birds, rodents or micro-organisms.

Make sure that the building is big enough for your production, but do not pay for extra space that you do not need.

Within the building, food should move between different stages in a process without the paths crossing (Fig 2.1). This reduces the risk of contaminating finished products, as well as

reducing the likelihood of accidents or operators getting in each other's way. There should be enough space for separate storage of raw materials, packaging materials and finished products.

Fig. 2.1. Basic design for a roots and tubers processing unit
(hand-washing/changing facilities and toilets in another building)

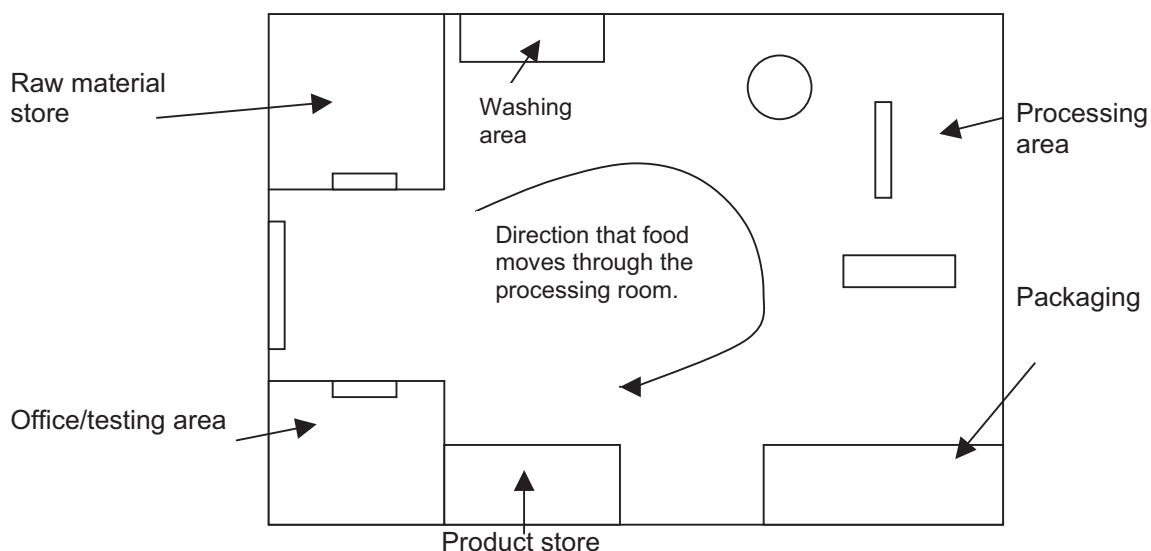

The arrows indicate the direction that food moves through the processing room.

Roofs and ceilings

Overhanging roofs keep a building cooler, and fibre-cement tiles provide greater insulation than galvanised iron sheets against heat from the sun. A panelled ceiling should be fitted in processing and storage rooms, rather than exposed roof beams, which allow dust to accumulate and fall off in lumps and contaminate products. Beams are also paths for rodents and birds, creating contamination risks from hairs, feathers or excreta. It is important to ensure that there are no holes in the ceiling or roof, and no gaps where the roof joins the walls, which would allow birds, rodents and insects to enter.

Walls, windows and doors

All internal walls should be plastered or rendered with concrete. The surface finish should have no cracks or ledges, which could harbour dirt or insects. The lower parts of the walls are most likely to get dirty from washing equipment, and they should either be tiled to at least 1.5 metres above the floor, or painted with waterproof white gloss paint. Higher part of walls can be painted with good quality emulsion paint if tiling is too expensive.

Natural daylight is preferable to, and cheaper than, electric lighting in processing rooms. The number and size of windows depends on the amount of money that a processor wishes to invest, and the security risk in a particular area (windows are more expensive than walls, especially when security bars or grilles are needed). Storerooms do not need to have windows. There is a natural inclination for workers to open windows to let in fresh air, but this provides easy access for flying insects. Windows should therefore be screened with mosquito mesh. Window sills should be made to slope, to prevent dust accumulating and to

prevent operators leaving cleaning cloths or other items lying there, which can attract insects.

Storeroom doors should not have gaps beneath them, and should be kept closed to prevent insects and rodents from getting in and destroying stocks of crop. Normally doors in processing rooms should be kept closed, but if they are used regularly there is a tendency for them to be left open, allowing animals and insects to enter the plant. Thin metal chains, or strips of plastic or cloth can be hung from door lintels to deter insects and some animals, while allowing easy access for staff. Alternatively, mesh door screens can be fitted.

Floors

Floors in processing rooms and storerooms should be made of good quality concrete, smooth finished and without holes or cracks. Paints can protect floors, but vinyl-based floor paints are expensive. Red wax household floor polishes wear away easily and could contaminate products. The best way to protect floors is to clean up spillages as they occur and make sure that the floor is thoroughly washed after each day's production.

Dirt can collect in corners where the floor and the walls join. To prevent this, the floor should be curved up to meet the wall. The floor should also slope to a drainage channel. Proper drainage prevents pools of stagnant water forming, which would allow insects to breed. The drainage channel should be fitted with metal gratings that are easily removed so that the drain can be cleaned. Rodents and crawling insects can also get into the building through the drain, and a wire mesh cover should be fitted over the drain opening. This too should be easily removed for cleaning.

Services

Lighting and power

Where lighting is needed and electricity is available, florescent tubes use less electricity than light bulbs. Power points should be located at least one metre above the floor so that there is no risk of them getting wet when the floor and equipment is washed down. Ideally, waterproof sockets should be used. Each power point should only be used for one application, and multiple sockets should not be used because they risk overloading a circuit and causing a fire. All plugs should have fuses that are appropriate for the power rating of the equipment, and the mains supply should have an earth leakage trip-switch. Cables should be properly fixed to walls or run vertically from the ceiling to machines. There should be no exposed wires at any connection. Larger electric motors should be fitted with a starter and isolator.

Water supply and sanitation

Water is essential in all root crop and tuber processing for washing crops and equipment. An adequate supply of potable water should be available from taps in the processing room. There are two potential problems with the water quality: sand and contaminating micro-organisms. If a processing unit is located in a rural area, there may be no mains supply, or it may be unreliable or contaminated. Water from boreholes is likely to be relatively free from micro-organisms, but may be contaminated with sand. River water is likely to be contaminated with micro-organisms and should only be used if no other source is available. Samples of water should be periodically checked (e.g. once per year) for microbial

contamination at the UNBS, Makerere University Department of Food Science and Technology, UIRI, or one of the commercial testing laboratories in Kampala.

Potable water is drinking water that is wholesome and clean and does not cause illness. It is free from any micro-organisms and parasites and from any substances, that in numbers and concentrations, constitute a potential danger to human health. It should meet standard US 201:1994 as established by UNBS.

To remove sediment, two high level covered storage tanks should be installed, either in the roof-space or on pillars outside the building. They are filled when mains water is available or with water pumped from boreholes. While one tank is being used any sediment in water in the other tank settles out. The capacity of each tank should be enough for one day's production. The tanks should have sloping bases and be fitted with drain valves at the lowest point to flush out any sediment that has accumulated.

If necessary, water should be treated to remove micro-organisms. There are four ways of treating water at a small scale: by filtration; by heating; by ultra-violet light and by chemical sterilants, such as hypochlorite (also known as 'chlorine solution' or 'bleach'). Other water treatment methods are likely to be too expensive for small scale producers. Domestic water filters are likely to be too slow for the large amounts of water required, and larger industrial filters could be considered. They are expensive, but once they are installed the operating costs are relatively low. Micro-organisms can also be destroyed by boiling water for 10-15 minutes. The main disadvantages are the high fuel costs and the time required to do this each day. Heating does not remove sediment, and boiled water may also need to be filtered. Ultra-violet light destroys micro-organisms in water and commercial treatment units are suitable for processors that use a lot of water. Again, this method does not remove sediment from the water.

Dosing water with bleach is fast, cheap and effective against a wide range of micro-organisms. Water for cleaning should contain about 200 ppm of chlorine (by mixing 1 litre of bleach into 250 litres of water). Water that is used to wash crops should not contain more than 0.5 ppm chlorine (by adding 2.5 ml of bleach to 250 litres of water), to avoid contaminating products with a chlorine odour. Care is needed when using bleach because it damages the skin and particularly the eyes, and can cause breathing difficulties if inhaled. It also corrodes aluminium equipment.

Good sanitation is essential to prevent contamination of products and to prevent pests from breeding in the processing unit. Equipment should be thoroughly cleaned after each day's production, using a cleaning schedule that is clearly understood and followed by production workers (see Section 6). Insects and rodents are attracted to food that is left lying around. Solid wastes should be placed in bins and removed from the building at intervals, rather than letting them accumulate during the day. Wastes should never be left in a processing room overnight. They should be taken away from the processing site and either buried or turned into compost. Large volumes of liquid wastes are created by washing crops, equipment and floors, and the starch that they contain is highly polluting. These wastes should be carefully disposed of to prevent local pollution of streams or lakes, which can remove oxygen from the water and kill all wildlife, including fish. If mains drainage is not available, a soak-away should be constructed in a place that cannot contaminate drinking water supplies.

Wastewater should not be allowed simply to soak into open ground, because this will create swampy conditions in which the starch rots, creating smells, attracting insects that could contaminate products, as well as introducing a health hazard.

Toilets should be separated from the processing area by two doors or be located in a separate building. Workers should have hand-washing facilities with soap and clean towels. A summary of guidelines on sanitation is given in Table 2.1. Hygiene and safety rules are given in Table 3.3.

Together, a manager and processing staff should develop a cleaning plan and personal hygiene rules to ensure product safety. For example, if staff reports a stomach illness or skin infection, they should be transferred to jobs that do not involve handling products. There should also be proper cleaning materials and equipment made available, and adequate time for cleaning machinery and processing areas after production has finished.

Table 2.1. Sanitation facilities required in the processing room

Sanitation facilities required in the processing room
<ul style="list-style-type: none">• A changing room where clothing and shoes that are not worn for work can be stored.• Separate hand-washing facilities for staff, with soap, clean water, nail brushes and clean towels. These should not be used for processing.• Toilets, which should be separated from the processing room by two doors or located in a nearby building.• First aid materials• Protective aprons or coats washed regularly, hats/hairnets, and if necessary, gloves and shoes.• Cleaning chemicals, stored away from the processing room.

Remember:
The Uganda Bureau of Standards will inspect each aspect of your production facilities before they will award a product registration certificate.
Please review the Code of Practice for Hygiene in the Food and Drink Manufacturing Industry, US 28:2001.
It is obtainable from the Bureau of Standards

Checklist 2

Can you answer these questions? Tick the box if you know the answer. Write notes on what you currently do or need to do to find the answer.

Question	Tick	Notes
1. Is your site close to supplies of raw materials?		
2. How can you reduce the cost of transporting raw materials to your site?		
3. Does the processing room have a panelled ceiling?		
4. Are the walls easily cleaned? What do you need to do to improve them?		
5. Are doors and windows protected against insects? If not what improvements do you need to make?		
6. Is the floor free of cracks and easily cleaned?		
7. Do you have drainage that is protected against entry by rodents?		
8. Are lighting and power adequate? What do you need to do to improve them?		
9. Are the amounts and quality of water adequate for processing?		
10. Do you have facilities for disposal of solid and liquid wastes that will not cause localised pollution?		
11. Do you have toilets and hand-washing facilities?		
12. Do your workers have a cleaning plan and do they follow good sanitation practices?		

3

Production Planning

Production planning involves thinking ahead to make sure that everything is in place to produce the required amount of product. Inadequate planning is a common failure by small-scale processors, which results in production having to stop because for example, not enough raw materials are bought, or there is not enough staff to produce the amount required in the time available.

If production stoppages happen frequently, the output from the unit falls below the planned capacity and the business cannot produce enough to pay the bills, and it fails. Successful business people are able to manage their cash flow, so that enough money is available to buy the inputs needed for production, before income is received from the sale of products.

Production planning is used to find the:

1. Number of workers required and their different jobs
2. Equipment needed to achieve the planned production level
3. Weights of raw materials to be bought
4. Number of packages required.

It can also identify any 'bottle-necks' in the process, and where quality assurance procedures should be used.

Carefully written plans can also help the entrepreneur to identify potential food safety risks and can be used to implement Good Hygienic Practice and Good Manufacturing Practice programmes.

Production can be planned using the calculations below. The information required to do this includes:

- How much product (kg) is sold (not made) each month?
- How many hours are worked per day?
- How many days are worked per month?

This information is first used to calculate the daily production rate, so that crops and packaging can be bought. Then the average amount of production per hour (termed the 'product throughput') can be calculated to find the size of equipment and numbers of workers required.

The first step is getting detailed information on current sales (Fig 3.1) by adding together the daily sales figures to produce monthly totals (these figures also show trends in sales which can be used to plan for additional equipment, new staff, or development of new products).

Fig. 3.1. Monthly sales chart

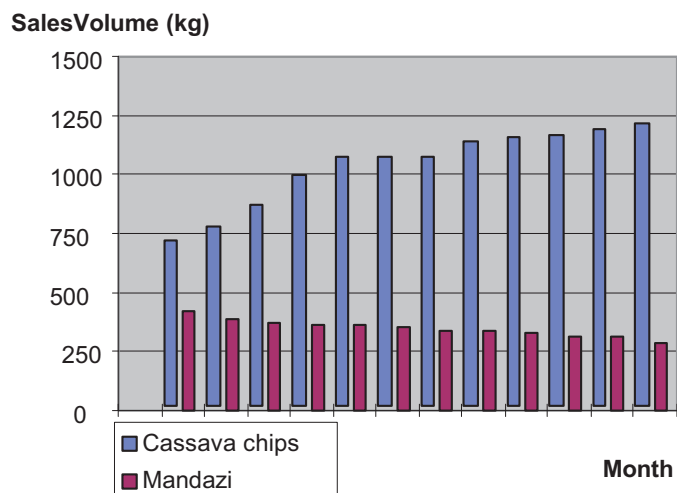

When starting up a business, projected sales information is used to find the daily production rate, so that ingredients and packaging can be ordered.

$$\text{Production rate (kg/day)} = \frac{\text{amount of product sold/month (kg)}}{\text{N}^\circ \text{ days production/month}}$$

Worked example 1: Calculation of production rate

From Fig 3.1:
 Sales of cassava chips are 1.24 tonnes per month. The processing staff work on Monday to Friday each week and therefore in a four-week month:
 the production rate = $1240 / (5 \times 4)$
 = 62 kg/day

The data is also used to calculate the average amount of production per hour (termed the 'product throughput') to find the size of equipment and numbers of workers required.

$$\text{Throughput (kg/hour)} = \frac{\text{amount of product sold/month (kg)}}{\text{N}^\circ \text{ days production/month} \times \text{N}^\circ \text{ hours worked/day}}$$

Worked example 2: Calculation of throughput

Using the data in Worked Example 1, and assuming that staff work for 8 hours per day, then the
 Average cassava throughput = $1240 / (5 \times 4) \times 8$
 = 7.75 kg/hour

Every effort should be made to ensure that these figures are as accurate as possible by carefully checking all the assumptions. One of the main causes of error is to over-estimate the number of working days, particularly if there are regular power failures, shortages of crop or if staff is often absent. The throughput figure allows the processor to decide the size and/or number of pieces of equipment that are required. In doing this, decisions need to be

taken on the relative benefits of employing a larger number of workers or buying machinery to do a particular.

Raw materials

Having decided how much product to make, a processor needs to calculate how much crop to buy. This depends on the likely levels of wastage and losses during the process. Losses arise from peeling, from substandard roots that are thrown away during sorting or from low quality or spoiled product. Typical losses are shown in Table 3.1, but it is important that processors measure these in their own process so that accurate figures can be used in the calculations.

Table 3.1. Typical peeling losses during the preparation of root crops

Root crop	Typical peeling losses (%)
Cassava	10-20
Coco-yam	10-20
Irish potato	5-15
Sweet potato	15-30
Yam	15-30

(Source: Fellows, P., Midway Technology Ltd, Bonsall, UK)

Table 3.2. Typical losses during processing of root crops.
(*does not include moisture loss)

Stages in a Process	Typical Losses
Washing	0-5
Sorting	5-50
Peeling	10-20
Slicing/dicing	5-10
Drying*	5-20
Packaging	0-10
Rejected packs	0-5

(Source: Fellows, P., Midway Technology Ltd, Bonsall, UK)

The amount of usable food after raw materials are prepared for processing is known as the 'yield', and is calculated as follows:

$$\text{Yield (\%)} = \frac{\text{weight of raw material actually used in the process}}{\text{weight of raw material that is bought}} \times 100$$

The true cost of raw materials depends on the yield and can be calculated as below:

$$\text{True raw material cost} = (\text{Supplier cost/yield}) \times 100$$

Worked example 3: Calculating the yield and true cost of raw materials

Cassava tubers cost USh 100 each and on average a single tuber weighs 250g (i.e. Ush 400/kg). 300 kg are bought for USh 120,000, and after peeling and slicing there are 240 kg available for processing.

$$\text{Yield} = \frac{240}{300} \times 100 = 80\% \text{ (i.e. 20\% is waste)}$$

$$\text{The true cost of the usable part of a single tuber} = \frac{100}{80} \times 100 = \text{USh } 125$$

If the process involves removing water (e.g. by drying), the amount of final product is calculated by knowing the solids content before and after processing as follows (see Section 6.1 for calculation of moisture content):

Worked example 4: Calculating the weight and value of a crop after drying.

Taking 240 kg of fresh cassava, initially it contains 80% water and 20% solids. Therefore 240 kg of cassava contain (80% of 240) = 192 kg of water and (20% of 240) = 48 kg solids. After drying the weight of solids has not changed (only water is removed) and the moisture content is reduced to 10%.

Therefore the solids content is (100 - 10) = 90%

$$\text{If 48 kg solids is 90\%, then the total weight of product} = \frac{100}{90} \times 48 = 53 \text{ kg}$$

And (240 - 53) = 187 kg water is removed

There were also losses of 800g due to rejected dried cassava. Therefore (53 - 0.8) = 52.2 kg of product is available for sale. Ignoring other production costs (labour, depreciation etc.) the value of the product is therefore:

Cost of raw materials	=	USh 120,000	=	USh 2298 /kg
Weight of product	=	52.2		

i.e. processing has increased the value of the cassava from Ush 400 /kg to nearly Ush 2300 /kg

It is in the interests of the processor to reduce losses as much as possible. Good quality raw materials and a well-managed process reduce wastage. This is especially important during later stages of a process when value has been added to the product.

Packaging

The considerations that need to be taken into account when selecting packaging materials include the technical requirements of the product for protection against air or moisture etc., the promotional and marketing requirements, and the relative cost and availability of different types of packaging. Depending on the product, root crops can be packed into paper or polythene bags/sacks, or in hessian or woven polypropylene sacks. These types of packaging are available in Uganda and can usually be printed by local print companies (see UNIDO Food Processing Equipment Directory).

The daily production rate is also used to calculate the numbers of packages required.

Worked example 5: Calculation of number of sacks required and time needed to fill and seal them

If 50 kg of dried cassava chips are produced per day and packed for retail sale into 500g bags:

$$\text{the number of packs required} = \frac{50 \times 1000}{500} = 100 \text{ bags}$$

If on average it takes a worker 1.5 minutes to fill, weigh and seal a bag,
the time required = (1.5 x 100) mins = 150 mins (2^{1/2} hours)
or if 4 people are working together the time required is just over half an hour.

Equipment

The throughput figure allows the processor to decide the size and/or number of pieces of equipment that are required. In doing this, decisions need to be taken on the relative benefits of employing a larger number of workers or buying machinery to do a particular job.

Worked example 6: Establishing the capacity of a cassava grater

From discussions with retailers (i.e. market research) a new cassava processor finds that the sales of cassava flour in a small town are estimated to be 5 tonnes per week. If the new business aims to capture 3% of this market, the amount of sales are 3% of (5 x 1000) kg = 150 kg/week or 600 kg/month. If production is expected to take place for five days per week, and two hours per day are set aside for grating the cassava (the remaining time is used for other stages in the process including peeling, milling, packing etc.):

$$\begin{aligned} \text{The throughput (kg/hour) required for the grater} &= \frac{\text{amount of product sold/month (kg)}}{N^{\circ} \text{ days production/month} \times N^{\circ} \text{ hours worked/day}} \\ &= \frac{600}{(5 \times 4) \times 2} \\ &= 15 \text{ kg/hour} \end{aligned}$$

Therefore a machine of this capacity could be ordered from manufacturers (or slightly higher capacity to allow for expansion of production)

It is preferable wherever possible, to buy equipment from local suppliers or engineering workshops because it should be faster and easier to get servicing and spare parts. Information on suppliers of equipment is given in the UNIDO Food Processing Equipment Directory. However, if equipment has to be imported, the following points should be considered when ordering it:

- Specify exactly what is required (many manufacturers have a range of similar products).
- Give the throughput required in kg per hour and the type of food to be processed
- Where possible, give other information (model number of machine, single or three-phase power, number and types of spares required).

Another source of information on equipment is a database at UMA, or contact can be made with USSIA or UNIDO to use their Internet access to locate databases of equipment manufacturers. Information on equipment importers is also available at offices of development agencies, Makerere Department of Food Science and Technology, UIRI, NARO or at embassies of exporting countries. (See contacts in Annex A).

Equipment maintenance

Another reason for lost production is delays caused by waiting for spare parts after equipment breaks down. As a minimum, processors should monitor the state of equipment that is likely to wear out, and as their experience grows over the years, they should buy spare parts or send the machine for servicing when they expect that a component is due to be replaced. There are likely to be a few parts that wear out more quickly than others (e.g. grater blades, drive belts and hammers in mills). These should be identified and spare parts kept in stock (Section 5). If electric motors are used in the process, they can be re-wound by electricians in urban centres. Similarly diesel motors require periodic servicing and processors can make an agreement in advance with a mechanic, possibly involving a small annual fee, to ensure that they are maintained or repaired as a priority.

Staff

The numbers and types of workers needed to operate a root crop processing business depend on the amount of production and also on the degree of mechanisation of the process. Machinery that is used in labour-intensive parts of a process, such as peeling or grating machines, can significantly reduce the numbers of workers needed. However, a processor needs to carefully calculate the expenditure on labour against the cost of maintenance, spare parts and possibly loan repayments from buying the equipment.

It is possible to have all workers doing the same type of work throughout the day (e.g. everyone peels the crop together then moves on to load a dryer together, and then all pack the dried products from earlier production). However, it is often more efficient to allocate different jobs to each worker as the day progresses. A convenient way of planning this is to draw an Activity Chart (Figure 3.2). This shows the type of work that is to be done each hour during the day, the number of people involved and the sequence of work that individuals do during the day. This type of chart can also be used to train workers in each of the different jobs so that there is flexibility for people to cover for each other during staff absences. It is important also to include work such as store management; quality assurance and bookkeeping when planning staff levels.

Figure 3.2 Activity chart used to plan job allocations for staff

Time	Supervisor	1 st operator	2 nd operator	3 rd operator
8 am	Management/book keeping	Washing/sorting crops	Washing/sorting crops	Store management
9 am	Management/book keeping	Peeling/slicing crop	Peeling/slicing crop	Peeling/slicing crop
10 am	Management/book keeping	Grating crop	Peeling/slicing crop	Unloading dryers
11 am	Management/book keeping	Grating crop	Cleaning	Loading dryers
12 am	LUNCH			
1 pm	Management/book keeping	Packing/ labelling	Cleaning	Loading dryers
2pm	Distribution	Packing/ labelling	Cleaning	Store management
3 pm	Distribution	Packing/ labelling	Packing/labelling	Store management
4 pm	Distribution	Buying crops	Buying crops	Preparation for next day's production
5 pm	Distribution	Buying crops	Buying crops	Preparation for next day's production

Health and safety

All processors have a responsibility to provide a safe and healthy working environment for their staff. This is a legal requirement in Uganda. Aprons or coats should be provided, and staff should be properly trained to use machines safely, particularly when cleaning them. The main dangers are from sharp blades on motorised cutters or graters or getting hands trapped in machines. The most frequent causes of accidents include:

- Improper adjustment and maintenance of equipment
- Poorly aligned drive belts to machinery
- Poor maintenance or use of incorrect spare parts
- Using incorrect tools for the machine.

Powered equipment should always have guards in place over drive belts and should preferably have working failsafe mechanisms such as electrical cutout switches, so that it automatically stops if the guard is removed. Workers should not wear clothes or jewellery that could become tangled in moving equipment. Details of safe working practices are shown in Table 3.3.

Table 3.3. Basic rules for hygiene, sanitation and safety in root crop processing

Hygiene and sanitation
<ul style="list-style-type: none"> • Clean the processing room, toilets and washing facilities, and storerooms every day. • Use the correct chemicals to clean equipment, make sure there are no food residues and rinse the equipment with clean water. • Make sure all cleaning cloths are washed and boiled each day. Do not hang them on equipment, products or window ledges to dry. • Do not leave dirty equipment until the end of the day before cleaning it. • Keep the area around the processing room clean and tidy. Keep grass cut short. • Put all wastes into bins that are not used for anything else. Empty the bins periodically during the day away from the processing site. • Prevent all animals from entering the processing area or storerooms. • Visitors should only enter the processing room wearing protective clothing and under supervision. • Wear clothing or jewellery that cannot get caught in machinery. • Wear a hat/hairnet that completely covers the hair. Do not comb your hair in a processing room or storeroom. • Cover all cuts, burns, sores and abrasions with a clean, waterproof dressing. • Do not smoke or eat chewing gum in any room where there is open food because bacteria can be transferred from the mouth to the food. • Do not spit in a processing room or storeroom. • Wash hands and wrists thoroughly with soap after using the toilet, eating, smoking, coughing, blowing your nose, combing your hair, handling waste food, rubbish or cleaning chemicals. Dry them on a clean towel before handling food again. • Keep finger nails cut short. • Do not wear perfume or nail varnish as these can contaminate products. • Do not handle any food if you have sores, boils, septic spots, a bad cold, sore throat or a stomach upset. Report any of these to the manager and do alternative work. • Do not cough or sneeze over food. • Keep food covered wherever possible. • Keep all food, tools and equipment off the floor. • Keep ingredients in sealed containers. • Do not use broken or dirty equipment. • Report any signs of insects, rodents or birds to the manager.
Safe working
<ul style="list-style-type: none"> • Wear shoes that protect your feet from falling objects. • Cover burning electrical equipment with a damp cloth or sand. Never use water to put out flames. • Shield gas burners from direct sunlight because the flames can become invisible. • Do not put cleaning fluids into old food containers. • Do not allow customers, children, visitors or animals into the mill or bakery building. Ensure that only trained staff enter the premises or operate machines. • Prevent staff wearing any loose clothing that could become caught in running machines. Provide them with overalls.

- Do not allow staff to start a machine unless they know how to stop it. Only one person should operate a machine at any one time.
- Make the layout of machinery logical, and leave sufficient space around it so that there are few chances for operators to get in each other's way.
- Do not try to attract operators' attention by touching or calling them from behind if they are using a machine. Always speak to them from the front, or wait until they have finished what they are doing.
- Train staff to be familiar with potential hazards (e.g. potentially dangerous machines), and what they should do in case of an accident. Use charts hung on the wall near to each machine to show safety precautions
- Ensure that guards are fitted and in place over any moving parts of a machine and alert staff to machines that appear to be standing still when running at high speed
- Never allow staff to clean, adjust or lean over moving machinery and do not allow them to leave a running machine un-attended
- Encourage operators to report any loose parts on a machine
- Do not allow staff to work with equipment that is defective. Put a note on any machine that is under repair saying 'DO NOT TOUCH'
- Do not allow anyone to touch inside electric equipment while it is connected
- Regularly check the cords of electrical appliances to ensure that outside covers are not broken and wires are not exposed.
- Prevent staff from running inside a building. Immediately clean up any water, oil or grease on the floor using sawdust, sand, husks etc.
- Have a first aid box containing sterilised dressings, cotton wool, adhesive plasters and bandages.

(Adapted from: The Food Hygiene Handbook, by Sprenger , 1996 and Fellows & Axtell, 2002)

Record Keeping

There are four sets of records that should be kept by the owner of a small processing unit (Table 3.4). Keeping records is an investment of time and money, and this must be related to the scale and profitability of the business (the benefits must outweigh the costs).

Records must therefore be used for them to have any value.

This means that the processor must understand why the information is collected and what it can be used for. Processors should also put in place a system of checks to ensure that one person does not have responsibility for a whole area of record keeping. For example the person who keeps records of crop purchases should be different to the person who records levels of stocks and manages the storeroom (Fig. 3.2).

Table 3.4. Types of records for a small scale processing business

Type of record	Information to be recorded
Production records	Raw materials received, and suppliers' details Wastage % at different stages of the process Stock levels for each raw material Production volumes Maintenance routines, details of spares kept in stock
Quality assurance records	Measurements made at process control points (Section 6.1) Batch numbers and product code numbers Cleaning schedules
Sales records	Names of customers and amounts sold to each Weekly and monthly sales volumes for each product
Financial records	Income from sales Costs of all process inputs Staff records (salaries etc) Cash flow Profit/loss Tax records Bank statements

Checklist 3

Can you answer these questions? Tick the box if you know the answer. Write notes on what you currently do or need to do to find the answer.

Question	Tick	Notes
1. Do you know how to calculate your production rate?		
2. Do you know how to calculate the amounts and true costs of crops required for a given production rate?		
3. Do you know how to calculate the yield of product and levels of wastage?		
4. Do you know how to calculate moisture losses during drying?		
5. Do you know how to plan labour requirements and how to allocate jobs to different workers to maximise efficiency?		
6. Can you calculate the size of equipment required using product throughput?		
7. Do you have correct maintenance procedures for your equipment?		
8. Have you developed safety training and checked the process to ensure that equipment and procedures are safe?		
9. Do you keep adequate records?		

4 **Products and Production Methods**

There is a limited range of processed root crop products that are made in Uganda. They include chips and flours made from cassava and sweet potato. Cassava is also fermented to produce gari and other flours. Fried snack foods are made from Irish potato, sweet potato and cassava. There is potential for fried products made from other root crops and these could be explored as new products. One or two processors have made sweet potato jam and this has proved popular among some consumers.

Fried products

All starchy roots including Irish potato, sweet potato, cassava etc., can be fried and eaten as snack foods (Table 4.1). Heat destroys enzymes and micro-organisms, and moisture is removed which prevents re-contamination. When products are packed in moisture-proof, lightproof and airtight containers, they can have a shelf life of several weeks or months. The main cause of spoilage is rancidity of frying oil that remains on the product.

The temperature during frying should be carefully controlled, preferably using an electric fryer with a thermostat control. The temperature of the oil should not be allowed to get higher than the 'smoke point' of the oil (when a blue haze forms above the oil). If this happens, it is a sign that the oil is breaking down, getting thicker and developing an unpleasant flavour that makes the product unacceptable. When the oil gets thicker, more of it sticks to the product, which increases production costs and reduces the product shelf life.

Table 4.1. Process for fried root crops and tubers

Stage In Process	Notes
Inspect ↓	Select raw materials that are fresh and have a firm texture without visible damage, rots or mould growth. Remove any mouldy or rotting roots or tubers. Remove all contaminants (leaves, stalks, stones, etc). Poor quality raw materials produce poor quality, and perhaps unsafe, finished products.
Wash ↓	Use wash tanks or special washers with potable water to remove surface contaminants, (e.g., insects and dirt).
Sort/grade ↓	Sort by hand on a sorting table for similar shape and size if these are important in the final product. Remove any shrivelled roots or tubers.
Peel ↓	Using a manual or mechanised peeler. Check that all traces of peel are removed. Remove any small areas of damaged or mouldy roots or tubers.
Slice ↓	Using a knife or slicing machine (a thinner, more uniform product can be made using small manual or electric slicing machines). Check that the thickness of slices is 1-2 mm.
Wash ↓	In a wash tank to separate the slices. Citric acid, lemon juice or sodium metabisulphite (at 10 g/litre) can be added to the wash water to prevent darkening caused by enzymic browning.
Drain ↓	To prevent excess water being added to the hot oil
Fry ↓	At 180-200°C for 5-10 minutes using a pan over a fire or in a deep fat fryer, until the required golden colour has formed. Regularly check oil quality (see text). Care is needed when adding slices to hot oil to prevent it splashing and burning operators.
Drain/cool ↓	On racks or mesh. Collect drained oil and reuse it. Cool product to room temperature to prevent condensation forming inside the package.
Pack/label ↓	In polythene bags using a heat sealer. Check the fill weight. Check that the seal is correctly formed because the product shelf life is reduced if air or moisture enters through a poorly formed seal. Polypropylene gives a longer shelf life than polythene. If a paper label is used, this should either be on the outside of the pack or a double layer of film is used to avoid oil seepage into the paper.
Store	Store away from heat and sunlight to avoid the development of a rancid taste in the product.

Dried chips

Drying preserves root crops because it removes most of the water needed by spoilage enzymes and micro-organisms. Crops can be blanched to prevent browning by destroying enzymes in the root, and to reduce the number of contaminating micro-organisms (This is needed because the temperature of drying is not high enough to kill them). Sliced roots are blanched by immersing them in boiling water in a wire basket for 3-5 minutes.

Sulphur dioxide protects the natural colour of root crops and prevents browning. It can be produced either by burning sulphur (sulphuring) or using a solution of sodium sulphite, sodium metabisulphite or potassium metabisulphite (sulphiting). In sulphuring, sliced crops are placed on mesh trays inside a wooden cabinet. 350-400g sulphur are burned per 100kg crop for 1-3 hours, depending on the type of crop, its moisture content and legal limits on residual sulphur dioxide in the product (Section 6.2). In sulphiting, the chemical is either added to the blancher water or made into a sulphite dip. Sliced crops are dipped for 5-10 minutes. About two thirds of the weight of sodium metabisulphite is present as sulphur dioxide when it is dissolved in water. A 0.001% (1000 ppm or 1 g/litre) solution is therefore made by dissolving 1.5g sodium metabisulphite/litre. The residual sulphur dioxide level is important if dried chips or flours are made for export, because many importers specify either very low levels or do not allow its presence. It should not be used for organic dried crops. Processors should consult their buyers to find out what level is acceptable.

Table 4.2. Process chart for dried root chips

Stage In Process		Notes
Essential	Optional	
Crop ↓		Harvest as carefully as possible to reduce cuts, bruising and other damage.
Inspect ↓		Select raw materials that are fresh and have a firm texture without visible damage, rots or mould growth. Remove any mouldy or rotting roots or tubers. Remove all contaminants (leaves, stalks, stones, etc.
Wash ↓		Use wash tanks or special washers with potable water to remove surface contaminants, (e.g., insects and dirt).
Sort/ grade ↓		Sort by hand on a sorting table for similar shape and size if these are important in the final product. Remove any shrivelled roots or tubers.
Peel ↓		Peel prevents moisture leaving the food and peeling allows faster blanching, sulphur dioxide treatment and drying. Peel by hand using knives or peelers, or using small peeling machines. Check that all traces of peel are removed.
Slice ↓		Uniform sized chips are important to get uniform drying times for all pieces. Cut by hand using sharp stainless steel knives, choppers, cutters, slicing or dicing machines. Check for uniform sized pieces.
	Blanch	Check water temperature and time of heating. Care is needed to prevent re-contamination of blanched foods before drying.
	Acid dip	Dip in 2% citric acid, lemon or lime juice for 5-10 minutes to prevent browning.
	Treatment with sulphur dioxide	In either a sulphuring cabinet or a food-grade plastic tank for a sulphite dip (see text). Check weight of sulphur or concentration of sulphite and time of exposure. Safety: do not breathe fumes. Sulphur dioxide causes coughing and eye irritation.
Dry ↓		For 1-2 days to 10-12% moisture content. The time needed for drying depends on the temperature, humidity and speed of the air, the type of dryer and the size of the food pieces. Check for mould growth, insect contamination and the temperature and time of drying,.
Pack ↓		For retail packs, use an electric heat sealer for moisture-proof, airtight plastic bags. Check fill-weight and seal. For bulk/wholesale sales use polypropylene, paper or hessian sacks, sealed with a sack stitche.
Label		Check that label is correct for type of product and properly aligned.
Store		Store in a cool dry place away from sunlight. Protect from crushing.

Flours

Root crop flours are made by grinding dried chips.

Table 4.3. Process chart for flour

Process stage	Notes
Dried chips ▼	See Table 4.2
Mill ▼	In a hammer mill. Sieve to ensure the required particle size
Pack ↓	Fill flour manually or using a bag filler. Check fill-weight. Seal paper bags with an electric sack stitcher or seal plastic bags with a heat sealer.
Label	Check that label is correct for type of product and properly aligned.
Store	Store in a cool dry place away from sunlight.

Fermented cassava/Gari

In Uganda cassava is fermented in three ways: a dry fermentation (Table 4.4), a wet fermentation (Table 4.5) and a rapid 'gari' fermentation (Table 4.6). It is then dried and milled to a flour, which is used as a staple in some parts of the country.

Dry fermentation

Naturally occurring moulds are allowed to grow on the peeled cassava and to soften it and assist in the removal of cyanide (see text in Section 1).

Table 4.4. Process chart for dry fermented cassava

Stage in Process	Notes
Cassava ↓	Harvest as carefully as possible to reduce cuts, bruising and other damage.
Inspect ↓	Select roots that are fresh without visible damage, rots or mould growth. Remove any mouldy or rotting roots. Remove all contaminants (leaves, stalks, stones, etc). Poor quality raw materials produce poor quality, and perhaps unsafe, finished products.
Wash ↓	Use wash tanks or special washers with potable water to remove surface contaminants, (e.g., insects and dirt).
Sort/ grade	Remove any small areas of mouldy root.
Peel ↓	Peel by hand using knives or peelers, or using small peeling machines. Check that all traces of peel are removed.
Heap ↓	Heap into piles and cover with banana leaves, grass or sacks. Leave for 4 days to allow mould growth. This removes toxic cyanide compounds.
Scrape ↓	Remove mould using a knife.
Pound ↓	To a pulp in a pestle and mortar
Dry ↓	The time needed for drying depends on the temperature, humidity and speed of the air and the type of dryer. Check for mould growth, insect contamination and the temperature and time of drying.
Pound/mill ↓	Mill to uniform particles, sieve flour.
Pack ↓	For retail packs, use an electric heat sealer to produce moisture-proof, airtight plastic bags. Check fill-weight and seal. For bulk/wholesale sales use woven polypropylene, paper or hessian sacks, sealed with a sack stitcher.
Label ↓	Check that label is correct for type of product. and is properly aligned.
Store	Store in a cool dry place away from sunlight.

Wet fermentation

The process uses a natural mixture of micro-organisms during soaking to soften the cassava and assist in removing cyanide.

Table 4.5. Process chart for wet fermented cassava

Stage in Process	Notes
Cassava	Harvest as carefully as possible to reduce cuts and other damage.
Inspect ↓	Select roots that are fresh without visible damage, rots or mould growth. Remove any mouldy or rotting roots. Remove all contaminants (leaves, stalks, stones, etc). Poor quality raw materials produce poor quality, and perhaps unsafe, finished products.
Wash ↓	Use wash tanks or special washers with potable water to remove surface contaminants, (e.g., insects and dirt).
Sort/ grade ↓	Remove any small areas of mouldy root.
Peel ↓	Peel by hand using knives or peelers, or using small peeling machines. Check that all traces of peel are removed.
Soak ↓	In clean water for 3 days to allow fermentation to take place. This removes toxic cyanide compounds.
Pound ↓	To a pulp in a pestle and mortar
Press ↓	Place pulp into bags and press out excess water.
Dry ↓	The time needed for drying depends on the temperature, humidity and speed of the air and the type of dryer. Check for mould growth, insect contamination and the temperature and time of drying.
Pound/mill ↓	To uniform particles, sieve flour.
Pack ↓	For retail packs, use an electric heat sealer to produce moisture-proof, airtight plastic bags. Check fill-weight and seal. For bulk/wholesale sales use polypropylene, paper or hessian sacks, sealed with a sack stitcher.
Label ↓	Check that label is correct for type of product and is properly aligned.
Store	Store in a cool dry place away from sunlight. Protect from crushing

Gari

Gari is a fermented cassava product, made by allowing naturally occurring micro-organisms to act on the pulp. Cyanide is released during the fermentation and is driven off during roasting.

Table 4.6. Process chart for gari production

Stage in Process	Notes
Cassava ▼	Harvest as carefully as possible to reduce cuts, bruising and other damage.
Inspect ↓ ▼	Select roots that are fresh without visible damage, rots or mould growth. Remove any mouldy or rotting roots. Remove all contaminants (leaves, stalks, stones, etc). Poor quality raw materials produce poor quality, and perhaps unsafe, finished products.
Wash ▼	Use wash tanks or special washers with potable water to remove surface contaminants, (e.g., insects and dirt).
Sort/ grade ▼	Remove any small areas of mouldy root.
Peel ▼	Peel by hand using knives or peelers, or using small peeling machines. Check that all traces of peel are removed.
Grate ↓ ▼	Using manual or motorised grater.
Press ↓ ▼	Place pulp into bags and press out excess water
Ferment ▼	Place dewatered pulp in sacks for 1 day for mild gari or up to 4-5 days for a more acidic taste
Sieve ↓ ▼	To remove lumps, particles and fibres
Fry/roast ↓ ▼	At 80-120°C for 2-5 mins in a heavy metal pan, coated with oil. This dries the pulp to 8-12% moisture and removes toxic cyanide. Constantly stir the gari and toss it in the air to prevent it sticking to the pan and burning. Check colour change to creamy colour to indicate the end of roasting.
Cool ↓ ▼	On racks in the shade
Sieve ↓ ▼	To remove fibres, lumps and particles. It may be milled or pounded and re-sieved.
Pack ↓ ▼	For retail packs, use an electric heat sealer for moisture-proof, airtight plastic bags. Check fill-weight and seal. For bulk/wholesale sales use polypropylene, paper or hessian sacks, sealed with a sack stitcher.
Label ↓ ▼	Check that label is correct for type of product. and is properly aligned.
Store	Store in a cool dry place away from sunlight.

Mandazi

This is a fried product made using sweet potato or cassava, mixed with wheat flour, sugar and oil. Baking powder is used as a raising agent to give an aerated texture to the product. Different recipes for mandazi are given in Table 4.7.

Table 4.7. Recipes for mandazi

Ingredient	Quantity (g)			
	Root crop	400	600	800
Wheat flour	1600	1400	1200	800
Sugar	130	130	130	130
Oil	18	18	14	14
Baking powder	30	30	30	30

Table 4.8. Process for mandazi

Stage In Process	Notes
Root crop flour ↓	Fresh pulp may be substituted for up to 60% of the root crop flour
Mix ↓	Mix all the ingredients except oil in a bowl. Make a hole in the centre, all the oil and mix. Add water a little at a time to make a soft dough.
Form into shapes ↓	Roll out the dough to 0.5 cm thick and cut to desired shapes
Fry ↓	At 160-180°C for 5-6 minutes using a pan over a fire or in a deep fat fryer, until the required golden colour has formed. Regularly check oil quality (see text in 4.1).
Drain/cool ↓	On racks or mesh. Collect drained oil and reuse it. Cool product to room temperature.
Pack /label ↓	Optional - In polythene bags using a heat sealer. Check the fill weight. Check that the seal is correctly formed. If a paper label is used, this should either be on the outside of the pack or a double layer of film is used to avoid oil seepage into the paper.
Store	Store away from heat and sunlight to avoid the development of a rancid taste in the product.

Sweet potato jam

Sweet potato jam is made from pulped root with added sugar, pectin and citric acid. The combination of high acidity (pH around 3.0) and high sugar content (68-72%), prevents mould growth after opening the jar. There are two important points to remember when making jam:

- 1) There must be the correct proportions of pulp, sugar, acid and pectin in order to form a good gel.
- 2) Water must be boiled off quickly to concentrate the mixture before it darkens. A stainless steel pan and a gas burner can be used, and the mixture should be constantly stirred to prevent it burning onto the base of the pan, particularly towards the end of boiling when it thickens.

Methods to test for the correct point to stop boiling are described in Section 6.1, and a summary of common faults in jam making is shown in Table 4.10.

Pectin is available commercially as either a powder or a liquid concentrate. It is stable if stored in cool, dry place and it will only lose about 2% of its gelling power per year. Powdered pectin is added to the sweet potato pulp at 3-6g per kg of final product, but it should first be mixed with about five times its weight of sugar to prevent lumps forming when it is added to the pulp. Liquid concentrate can be added directly to the pulp. There are a large number of different types of pectin, such as 'rapid set' and 'slow set' and it is necessary to specify carefully the type required when ordering pectin from a supplier.

Jam should be hot filled (at around 85°C) into glass jars and sealed with a new lid. If the temperature is too high, steam condenses to water on the inside of the lid and dilutes sugar at the surface of the jam, which can cause mould growth. If the temperature is too low, the jam thickens and is difficult to pour into containers. Jars should be filled to approximately 9/10^{ths} full, to help a vacuum to form in the space above the product as it cools. The problems of obtaining glass jars in Uganda have led some producers to use polythene tubs, but these are not easy to hot-fill because they melt, and the lid seals are often not good enough to prevent product leaking out and attracting insects. Polypropylene pots are more suitable, especially if a heat sealed foil lid is used.

Table 4.9. Process for sweet potato jam

Stage of Process	Notes
Sweet potato ▼	Mature but not over-ripe without mould growth, harvested carefully to prevent puncturing, splitting or bruising etc.
Inspect ↓	Select sweet potatoes that are fresh without visible damage, rots or mould growth. Remove any mouldy or rotting roots. Remove all contaminants (leaves, stalks, stones, etc). Poor quality raw materials produce poor quality, and perhaps unsafe, finished products
Wash ▼	Use potable water in a wash tank to remove surface contaminants, (e.g., insects and dirt)..
Sort/grade ▼	Sort by hand on a sorting table. Remove discoloured parts
Peel ↓	Using sharp stainless steel knives or small peeling machines. Check that all traces of peel are removed
Slice ▼	By hand into slices of approximately equal thickness
Heat ↓	Partially cook in boiling water to soften the slices. Check the time of boiling
Pulp ▼	By hand or using a liquidiser
Mix ↓	Add approximately equal weight of sugar to weight of pulp, and citric acid to obtain pH 3.0-3.3. Add pectin. A preservative, such as 1.8% sodium benzoate is optional.
Heat ↓	To 104-105°C in a stainless steel boiling pan for 15-20 mins., or until the solids content reaches 68-70%, measured by refractometer. Check temperature and time of boiling. Check to ensure that colour does not darken excessively.
Fill & Seal ↓	Hot-fill into pre-sterilised jars (boiled in water or in an oven at 100°C for 10-15 mins) or in plastic pots or sachets if they can be sealed against insects. Seal and check fill- weight and seals. Re-used bottles should be carefully washed using detergent and thoroughly rinsed. A bottle rinser can be used to save time.
Cool ▼	To room temperature, upright on a table or using a bottle cooler (optional).
Label ↓	By hand or with label applicator. Check that the correct label is used and that label quality is satisfactory. Check that each one is correctly aligned.
Store	Store in cool dry place away from sunlight

Table 4.10. Common faults in making jam

Fault	Possible cause	Prevention
1 Gel does not set or is not firm	<ul style="list-style-type: none"> • Incorrect pectin type • Too little pectin • Solids content too low • Incorrect pH value • Pectin not fully dissolved • Boiling for too long • Pectin solution too old • Pre-setting • Holding at high temperature for too long (pan too big) 	<ul style="list-style-type: none"> • Select correct type of pectin • Check formulation • Add more sugar • Check pH, adjust with citric acid • Mix with sugar before dissolving • Produce smaller batches • Use new stock • Increase filling temperature • Lower filling temperature, make smaller batches or use slow-setting pectin
2 Gel too firm	<ul style="list-style-type: none"> • Too much pectin • Solids content too high • pH too low 	<ul style="list-style-type: none"> • Check formulation • Heat less, add less sugar or add more water. • Adjust pH
3 Pre-setting	<ul style="list-style-type: none"> • Filling temperature too low • Filling time too long. • Solids content too high • pH too low 	<ul style="list-style-type: none"> • Increase filling temperature or choose slow-setting pectin • Produce smaller batches or use slow-setting pectin • See above • See above
5 Syneresis (cracked gel with oozing liquid)	<ul style="list-style-type: none"> • Pre-setting due to low filling temperature • pH too low 	<ul style="list-style-type: none"> • See above • Adjust pH

Checklist 4

Can you answer these questions? Tick the box if you know the answer. Write notes on what you currently do or need to do to find the answer.

Question	Tick	Notes
1. Do you know how to correctly prepare raw materials, and process and pack the following products?		
• Dried chips		
• Flours		
• Fried products		
• Fermented cassava/Gari		
• Mandazi		
• Sweet potato jam		
2. Do you know which of the above products have an increasing demand?		

5 Equipment

The equipment required for root crop processing is described in the following section. A summary of the spare parts that should be kept in stock and equipment maintenance requirements is shown in Table 5.1. Details of cleaning requirements are given in Section 6 and Table 3.3.

Table 5.1, Summary of spares and maintenance/cleaning requirements for root crop and tuber processing equipment

Type of equipment	Spares kept in stock	Maintenance required	Cleaning
Bagging machines	Dust gaiters	See next section	Remove dust each day
Blanchers	None	None	After use with detergent and clean water
Boiling pans	None	None	After use with detergent and clean water
Bottle coolers	None	None	None
Chippers	Replacement blade	Periodically sharpen blade	After use with detergent and clean water
Deep fat fryers	None	None	Periodic (monthly) removal of oil and cleaning
Dicers	Replacement blade	Periodically sharpen blade	After use with detergent and clean water
Dryers	Plastic covers, preferably UV resistant	Replace polythene cover each year or replace polyester cover every 3-5 years	Cleaning trays after use with detergent and clean water
General tools, work tables	None	None	After use with detergent and clean water
Graters	None	Periodically sharpen blade	After use with detergent and clean water
Jam thermometers	None	None	Carefully wipe with a clean cloth
Labellers	None	Daily, check guide position	Daily - wipe down surface with damp cloth
Laboratory glassware/equipment	None	None	After use with detergent and clean water, rinse with distilled water
Mills	Hammers	See Table 5.3	Brush out dust, clean motor after use
Motors, isolators and starters	None	Weekly check on wiring and bearings	Weekly wipe down with clean cloth

Packing tables	None	None	After use with detergent and clean water
Peelers	Replacement blade	None	After use with detergent and clean water
pH meters	Buffer solutions, probe	Monthly standardisation	Wipe carefully with damp cloth after use
Presses	None	None	After use with detergent and clean water
Protective gloves, hats, hairnets, coats, boots	None	None	Weekly laundry for coats, daily washing of boots. Others to laundry as required
Refractometers	None	None	Cleaning each day
Roasters	None	None	After use with detergent and clean water
Sack stitchers		See Section 5.30	Brush out dust
Scales	None	None	Monthly standardisation with known weights
Sealers	Replacement heater wire and cloth	None	None
Slicers	Replacement blade	Periodically sharpen blade	After use with detergent and clean water
Sulphuring cabinets	None	None	Cleaning trays after each batch

Larger machines require a concrete solid foundation, and should be securely bolted to the floor using foundation bolts. There should be a space around the machines of at least 60 cm for maintenance and cleaning. It is important to have good air circulation to enable the machinery to run at correct temperatures, especially those that use an electric motor or a diesel engine to avoid them over-heating.

Maintenance of equipment

A common reason for lost production is delays caused by equipment breakdowns and waiting for spare parts. Most small-scale producers do not keep a stock of spare parts because of the cost, but very few producers have compared the cost of a stock of spares with the cost of delayed production. For some it may be cheaper to keep a supply of spares. In most enterprises, there are a few items of equipment that are likely to wear out more quickly than others (e.g. bearings, heating elements etc.). The entrepreneur should therefore identify the specific parts of equipment that are likely to fail most often and ensure that spares are always kept in stock.

Lack of maintenance is one of the most common problems that cause small-scale processors to lose money. Machine breakdowns arise from a number of different causes. They reduce productivity and increase production costs. Poorly maintained machines also produce substandard products and can contaminate products with metal fragments, as well as being a potential hazard to operators. Another common cause of failure is when those who operate or maintain a machine arbitrarily alter it.

To put preventive maintenance into practice, the following actions are needed:

- Identify priority machinery which have components that wear out more frequently
- Make a clear description of the procedures and standards for the work of machine operators and maintenance workers (such as lubricating, tightening bolts, adjustments etc.) In daily, weekly and monthly routine maintenance plans
- Organise a schedule and train staff to implement maintenance plans.
- Prepare a maintenance budget
- Record inspection results, analyse the records and evaluate the success of maintenance
- Continuously update procedures and standards.

Machine breakdowns reduce productivity and increase production costs. Poorly maintained machines produce substandard products, contaminate products with metal fragments and are a potential hazard to operators. When proper maintenance is done, machinery operates correctly and safely, and has a longer life, thus reducing capital and operating expenses. The costs and benefits of planned maintenance depend on how quickly emergency repairs can be done and the value of the spares that have to be held in stock. If there is a local mechanic who can come quickly to repair a machine, it may not be necessary to keep a stock of spares, but if it is located far from such a person, a stock of spares is needed. There should also be a clear description for machine operators of the maintenance procedures and standards required (lubricating, tightening bolts, adjustments etc.) in daily, weekly and monthly routine maintenance plans, and staff should be properly trained to implement them. It is also important to remove dust from equipment each day. A build-up of dust causes:

- rust to develop
- moving parts to jam in electrical equipment
- greasing points on machines to seal over
- motors and engines to overheat, burn out or seize.

The design and construction of equipment, especially the quality of welding, should ensure that food cannot become trapped in recesses or on projecting welds, or release dust into the building. Well-designed equipment is easily dismantled for cleaning and maintenance. Good quality steel should be used for nuts and bolts that are regularly removed to prevent wear on threads. Worn bolts can fail and damage equipment, injure an operator or contaminate the product.

Bagging equipment

Flours are filled and sealed into paper or polythene bags for retail sale, or into polypropylene, multi-wall paper or cotton sacks for bulk sales. Most small-scale processors fill bags and sacks by hand and then check the filled weight on scales, but this is time-consuming. Faster filling can be achieved using a manual or semi-automatic bagging machine (Fig. 5.1), which is adjustable for different fill-weights. Flour is released from a hopper into a weighing section, and the correct weight is then dropped into a bag or sack.

An auger carries flour to the weighing/bagging machine. It is important that this is set up correctly because the product feedrate of the auger affects the accuracy of the weighing/bagging. Two bolts join sections of auger machine and it is important that the spring washers are in place and the bolts are fully tightened (a loose bolt can severely damage the auger).



Fig. 5.1 Bagging machine

All connecting sleeves should be fully tightened to prevent the auger sagging (if this happens the auger will cut through the outer tube and destroy it). Guards should be fitted over all drive belts. A starter should be used for the conveyor motor, and located on a wall, not on the auger or motor. Never wire a motor directly to a socket. Wiring should be an adequate size to prevent a voltage drop and a competent electrician should set the overloads to match the rated current of the motor and check that it rotates in the correct direction.

If it is necessary to service the auger or remove a blockage, make sure that the motor is isolated and that all guards are replaced before reconnecting the power supply.

To operate the auger, switch on the motor and feed material into the intake end. If material does not flow evenly from the discharge end, check that:

- The motor is turning in the correct direction
- The auger is turning
- V-belts and chains are tightened
- Extensions are properly connected
- The auger turns freely in the tube
- Material is not bridging over the inlet
- An obstruction has not entered the auger tube
- The outlet spout is not obstructed by product (this will lead to a build-up of material in the tube which will damage the top of the auger)
- Flour is not damp as this could build up on the inside of the tube, reducing the clearance with the auger and eventually causing it to stall. If this happens, remove the auger and clean the tube.

The auger should not be run empty as this will cause severe wear on the intake end, and between the auger and the tube – causing the auger to cut through the tube.

**Remember
You are only issued with one set of fingers
– an auger can remove them with great efficiency and they are irreplaceable**

The bag filling and weighing machine should be set up on a level floor, and made exactly horizontal using the adjusters on the legs of the machine (the slope in any direction should not exceed 2°). A flexible connection should be made between the feed auger and the inlet. It is important to ensure that all linkages and push rods on the machine are able to move freely and are not obstructed by anything.

The machine can weigh out and fill bags in the range of 2 – 10 kg (the range is stamped on weigh beams within the machine casing. To set the exact filling weight, locate the front edge of the large sliding weight to the required position and lock it. Two bags are then positioned beneath the fillers, and the bag supports are adjusted so that the bags fit properly on the supports while they are being filled.

A continuous and even feedrate to the filler is needed to achieve accurate fill-weights. Once this is set, the rate should not be changed without recalibrating the filler. Under no circumstances, should the machine be over-fed with product or there will be a build-up of flour in the diverter chute and bagging boxes. Fill and check-weigh six bags from each side of the machine, discarded the first bag to be filled from each filling head. If needed, adjust the target weight using the coarse and then fine weight adjusters. The coarse adjuster has a range of $\pm 750\text{g}$ in 250g divisions. The fine and very fine adjusters are on a screwed rod that has a overall range of 700g front to back. One turn of the fine weight adjuster will alter the fill weight by 5g and one turn of the very fine adjuster will alter it by 1g. Each adjuster should be locked into position when the correct weight has been set. With all adjusters, movement to the front of the machine reduces the fill weight and movement to the back of the machine increases the fill weight. Each side of the filling machine should be treated independently.

Any variation in the feed rate or bulk density of the flour requires the fill weight to be re-adjusted

Worked example 7: Fill weight adjustment

Check-weighings show bags of flour to be 5250g compared to a target weight of 5kg. Adjust the coarse adjuster towards the front of the machine by one 250g division on the bar. Tests show that this gives a fill weight of 4980g. Use the fine adjuster and give 4 turns towards the back of the machine. The correct fill-weight of 5000g is now achieved and is set by locking the weights.

Maintenance

Ensure that counterbalanced weighing mechanisms are free to move up and down and the pushrods are free to move. Bearings are sealed and do not require lubrication. If metal bearings are fitted at the top of the pushrods, they should be lightly lubricated occasionally. It is essential to keep the machine clean of flour dust, especially on support trays, weighbeams and within the machine, otherwise inaccurate fill-weights may be produced. Regularly check dust gaiters on the bag clamp rubbers and replace them before they are worn out.

Any inaccuracies in weighing are likely to be due to one of the following causes:

- Movement of pushrods is restricted
- Product feed is not directed at the centre of diverter chute
- Product build-up on diverter chute because feedrate is too high
- Incorrect position of adjusting weights
- Variations in product feedrate

Polythene bags are heat-sealed. Paper bags and all types of sacks can be sealed using an electric sack stitcher (Fig. 5.18).

**Remember: Do-it-yourself electrical wiring can kill you.
Get a professional electrician for all electrical work!**

Blanchers

Hot water blanchers are made from aluminium pans. A mesh scoop is used to remove the hot root crops. Steam blanchers use the same pans, and have a removable mesh base to hold the roots above the boiling water. There is no maintenance required and pans should be cleaned with detergent and rinsed with clean water after use.

Boiling pans

A stainless steel (or less desirably aluminium) pan placed directly over the heat source is used to make sweet potato jam. There are two types of boiling pans: at smaller scales of operation, a simple stainless steel (or less desirably aluminium) pan can be placed directly over the heat source. However, viscous products such as jams are likely to burn onto this type of pan unless great care is taken to control the heat and thoroughly stir the mixture as it is being heated. This reduces the quality of the product and also significantly slows down production because the pan must be cleaned between batches. At a larger scale, a 'double

jacketed' stainless steel boiling pan is needed. Steam is produced in the space between the outer jacket and inner pan to give more uniform heating and avoid localised burning.

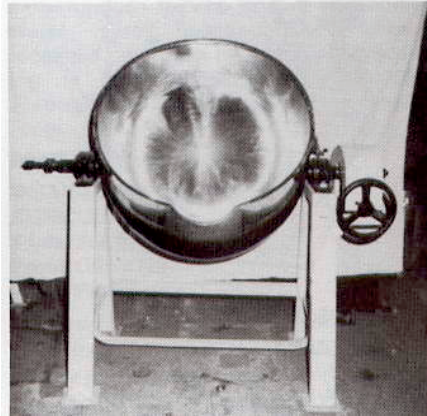

Fig 5.2. Boiling pan/pasteuriser

These are expensive to import and local fabrication in Uganda is difficult because the skills and facilities for welding stainless steel are available in only a few workshops (see UNIDO Food Processing Equipment Directory). There is no routine maintenance or requirement for spare parts. Pans should be thoroughly cleaned using detergent, ensuring that all burned-on food is removed before rinsing with clean water. The most appropriate type of heater depends on the cost and availability of different fuels in a particular area. In urban centres, gas or electricity is the preferred options because there is no risk of contamination of the product. In rural areas, these may not be sufficiently available or reliable and other types of fuel (e.g. charcoal or kerosene) have to be considered.

Bottle/jar coolers

These are used to increase the rate at which glass containers cool, by allowing the containers to pass through an inclined water bath. There is a flow of cooling water in the opposite direction to the containers. No spare parts are required, and no maintenance, except periodic emptying and cleaning to prevent a build-up of micro-organisms in the cooling water. If the quality of water is in doubt, it should be chlorinated.



Fig 5.3 Bottle cooler

Bottle/jar washers

The time consuming part of washing jars is rinsing out the detergent and washers are used to reduce this time. They are made by soldering vertical pipes onto a larger base pipe and connecting the base pipe to a water supply. In use the jars are inverted over the vertical pipes and rinsed until free of detergent. No spare parts are required, and there are no maintenance or cleaning requirement,.



Fig 5.4 Bottle washer

Chippers/Slicers

Manual slicing machines can be used to produce slices of uniform thickness for snackfoods or dried root crops. A range of manual, pedal or powered chippers is available for root crops. Most operate by holding the root against rotating blades, but machines that force the root past stationary blades or 'guillotine' type cutters are also available. The blades should be periodically sharpened and the equipment should be washed with detergent and clean water after use.



Fig 5.5 Powered chipper

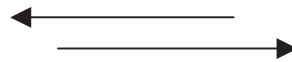

Fig 5.6 Manual slicer



Cyclone separators



Fig. 5.7 Cyclone separator

A fan sucks flour from the mill and transports it to a cyclone separator. In the cyclone, flour rotates inside in a spiral action and is separated from the air, causing it to drop into a collection bag underneath. The air escapes via a vent pipe at the top of the cyclone, preferably to the outside of the building.

It is important to design the cyclone separator correctly to avoid losing product into the air. The inlet pipe must enter the cyclone tangentially, and the outlet (vent) pipe should be three times the area of the inlet pipe.

The better the fan suction, the quicker the flour can be removed from the mill. The amount of suction depends on the following factors:

- The diameter of the air intake (it should be one third of the fan diameter. If it is smaller, insufficient air is drawn in and if it is larger air leaks from the edge of the fan intake).
- Smooth corners to ducting and pipes (Fig. 5.8)
- Sealed joints to reduce air leakage on the suction side and prevent air blowing out with loss of flour on the pressure side.

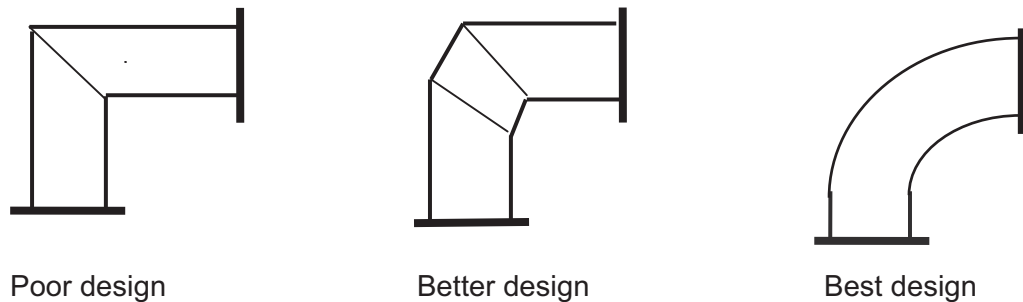

Fig. 5.8. Bend designs in pipe work for conveying flour from a mill (P. Tibasiimwa)

Deep fat fryers

The simplest fryer is a pan of oil over a fire, but there is little temperature control and a risk of burning both the oil and the product. The equipment supplied is a more sophisticated version of this for use in rural areas. **Warning: the equipment does not control the temperature of the oil and there is a risk of fire if it is allowed to become too hot.** Thermostatically controlled electric deep fat fryers overcome these problems. They can be imported or made by local workshops. The fuel-fired fryer has no maintenance requirement and no spare parts. When the oil becomes darkened (Section 4.1) it should be emptied, and the fryer cleaned with detergent and rinsed with clean water.



Fig 5.9 Deep fat fryer

Diesel engines

The engines are water-cooled with an attached fuel tank. They turn clockwise when looking at the flywheel with the exhaust on the left side. The speed of the engine is controlled by a governor and should not be increased.

Before starting for the 1st time or after an overhaul

1. Remove the crankcase door and fill troughs under connecting rods with oil
2. Apply oil to each oil hole on top of big end bearing
3. Open oil filler and fill engine sump with oil to 1 cm from top of filler
4. Operate lubricating oil pump by hand (or rotate the engine using the starting handle) until oil flows down over the main bearings and into the dipper troughs
5. Close crankcase and fill recesses in cylinder head with oil for valve lubrication
6. Fill cups in pushrods and tappet heads with oil
7. Remove brass plug near tappets (marked 'oil') and pour in 0.25 litres of oil
8. Fill rocker shaft greasers and give several turns to lubricate valve rockers



Fig. 5.10 Diesel engine

To start the engine by hand:

1. Check oil level, fuel level and coolant level before starting the engine
2. Prime fuel system (1st time started)
3. Swing valve lifter under tappets
4. Screw in tightly the compression changeover valve on cylinder head
5. Disengage governor hand lever by pushing it downwards and trip the overload pawl on the fuel pump
6. Place starting handle on the crankshaft extension and turn
7. Disengage the exhaust valve lifter as quickly as possible and lock it in the 'off' position (the engine should fire as soon as one valve has been released)
8. Remove starting handle
9. Check oil indicator plug to ensure that the oil pump is working
10. Check that coolant is circulating
11. Apply load as soon as the engine reaches full speed
12. For 1/3 load, keep compression changeover valve screwed in. For more than 1/3 load, open valve as far as it will go.

Engine maintenance

Daily	✓ Check levels of fuel, water and lubricating oil
	✓ Check oil around the valve stems and in push rods
	✓ Turn grease cups
	✓ Check water temperature
	✓ Check exhaust smoke
Every 100 hours	✓ Clean air filters
	✓ Check tightness of all nuts
Every 250 hours	✓ Apply drop of oil to governor linkage and fuel pump side window
	✓ Check drive belt and fan
	✓ Drain moisture trap in exhaust pipe
	✓ Remove fuel injectors and check fuel spray
Every 500 hours	✓ Clean compression valve screw and fuel filter
	✓ Change engine oil
	✓ Adjust valve clearance
	✓ Check lubricating oil strainer
Every 1000 hours	✓ Decarbonise engine
	✓ Grind in valves
	✓ Check piston clearance if gasket is changed
	✓ Clean out inlet manifold and exhaust pipe
	✓ Check water jacket for scale
	✓ Check the governor linkage is free to move
	✓ Renew the fuel filter
	✓ Check injector nozzles for wear
	✓ Check big end and main bearings

Time spent on proper maintenance will save costly repairs and lost time.

Dicers

Manual dicing machines first cut the material into strips and these are then cut into cubes. The machines produce uniform sized cubes, which are difficult to achieve using a knife. They should be washed with detergent after use and rinsed with clean water. The blade should be sharpened as needed.

Dryers

Sun drying has low capital and operating costs. But problems include contamination of the products by dust, birds, rats or insects, slow drying, and no protection from rain or dew, which encourages mould growth. There is little control over the drying conditions and products have variable quality. Provided that they are correctly designed, solar dryers have faster drying rates than sun drying because the air is heated to 10-30°C above the ambient air temperature. This also reduces its humidity and deters insects.

However, if root crops are dried too rapidly, this can result in 'case hardening' (see glossary in Annex B) and mould growth. However, drying rates are reduced on cloudy days and

dryers cannot be used at night. To overcome these problems a heater can be fitted to the drying chamber, but this obviously increases operating costs. The size and type of dryer depends on the anticipated production level, the amount of investment that can be afforded and the expected profitability of the business. The size of dryer can be calculated by assuming that 1m² is needed for 4 kg of sliced crop. There are very many different types of dryers and it is not possible to describe each in detail in a manual of this type. Design considerations are described in books listed in Annex A.

Solar dryers do not require spare parts or routine maintenance. However, ultra-violet light causes the plastic sheeting to deteriorate and it must be replaced periodically depending on the type of plastic used and the strength of the sunlight. Polythene needs replacing each year, UV resistant polythene and polyester every 2-3 years, and UV-resistant polyester every 3-5 years. Drying trays should be washed using detergent and rinsed with clean water after each use.

Gas burners/cylinders/regulators

The burner is connected to the cylinder using special orange rubber gas pipe and a regulator. The 'Jubilee' screw fittings that connect the pipe should be tightened as much as possible, and the joints should be tested by applying detergent and switching on the gas supply. Any sign of bubbles in the detergent should be investigated and the leak corrected. Care should also be taken not to damage the gas pipe by placing heavy objects on it or allowing it to get too close to the burner. There are no spare parts and no routine maintenance. The manufacturer has set the regulator and it should not be adjusted under any circumstances. If the gas flow becomes insufficient (and there is gas in the cylinder), a competent gas engineer from one of the gas supply companies should be called to correct the problem. The burner should be cleaned after use and when it is cool by wiping it with a damp cloth, ensuring that any food residues are removed.

General tools, worktables

All types of root crop processing require basic equipment such as buckets, tables, stainless steel knives etc. to prepare raw materials. Aluminium or stainless steel sheet is the preferred material for the surface of worktables. However, wooden tables are more widely used because of the high cost of these metals in Uganda. Wood is more difficult to clean, and if it is used it should be covered by a sheet of thick plastic, or a 'melamine' type surface. Food grade plastic should be used for all containers, rather than the yellow plastic containers that are widely available. Suppliers of food grade plastic vessels and metal tables are given in the UNIDO Food Processing Equipment Directory. There are no spare parts and no routine maintenance requirements. All tools and tables should be washed with detergent after use and rinsed with clean water.

Graters



A range of manual, pedal and powered graters is available, made from galvanised mild steel drums that have holes punched through the drum to produce a rough, rasping surface on the outside. There are no spare parts, but the grating surface should be periodically sharpened. The machine should be thoroughly cleaned and the grating surface scrubbed using a stiff brush with detergent and rinsed with clean water

Fig 5.12 Root crop grater

Heat sealers

These machines simultaneously melt and press plastic to weld two layers together, thus sealing a bag. A small bulb lights when the bar is pressed down and the bar should be released about one second after the light goes out (to allow the film to cool). The manufacturer's recommended settings are shown in Table 5.2. To find the correct setting, the control should be set at the minimum number and the sealer used to seal a bag. If no seal is formed, the control should be set to a higher number and re-tested. This should be repeated until a strong seal is formed. If the plastic burns or holes are formed in the seal the setting should be reduced.

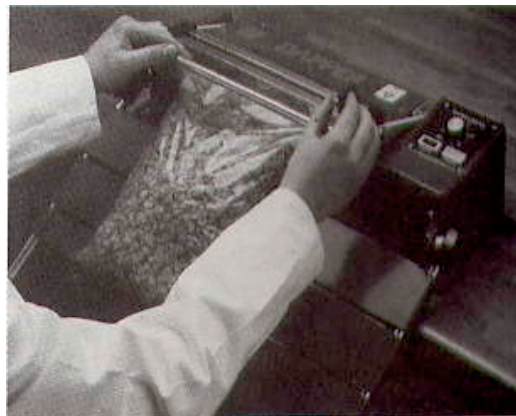

Fig 5.13 Heat sealer

A relatively wide seal (e.g. 3-5 mm) is required for dried foods and bar-type sealers are preferable to wire-types. Care should be taken to ensure that there is no product on the inside of the film where the seal is to be made, as this will prevent proper sealing. A sealing wire should be held as a spare. There is no routine maintenance and the sealer should be wiped clean weekly. Any burned-on plastic should be removed immediately by wiping the Teflon cloth and sealing bar using a cloth dampened with a suitable solvent (e.g. kerosene). If the Teflon cloth is torn, it should be replaced immediately because a torn cloth will short-circuit the heating element and damage it. The machine can be left plugged into the electric socket because it only uses power when the bar is pressed down.

Table 5.2 Heat sealer settings

Setting	Polythene	Polypropylene and other high-heat films
1	Less than 0.06 mm	
2	Less than 0.10 mm	
3	Less than 0.14 mm	
4	Less than 0.20 mm	Less than 0.030 mm
5		Less than 0.044 mm
6		Less than 0.06 mm
7		Less than 0.08 mm

Hosepipes and spray guns

A hose is used to wash down equipment, floors etc. The spray gun should be adjustable and to spray a single jet or a wide spray. No spare parts or routine maintenance are required and the hose and gun should be cleaned weekly by wiping it with a damp cloth.

Jam thermometers

This is a special thermometer that has readings up to 120°C and is strengthened to withstand sudden changes in temperature. It is inserted into boiling jam and the reading is used to determine when to stop boiling (Section 4.6). There are no spare parts or maintenance required. The thermometer should be cleaned by wiping it with a cloth when cool, and rinsing it in clean water. It should be stored in its protective casing.

Label applicators

A platform holds a stack of labels below an opening in the table, with the top label level with the surface. Glue is applied to the label and a round container is rolled over the opening and the label is picked up and pressed onto the container. The guide rails ensure that the label is applied in the same position on every container. There is no maintenance and it should be wiped clean with a damp cloth after use.

Laboratory glassware/equipment

The laboratory equipment includes glass beakers, flasks and a burette. Glassware should be cleaned with detergent and bottle brushes, rinsed with clean water and then rinsed again with distilled water (distilled water can be obtained from vehicle servicing and spares companies, where it is used to top up batteries). There are no routine maintenance or spares required.

Mills

Hammer mills have a chamber that is lined with a toughened steel beater bars (or a 'breaker plate') with an interchangeable screen at the base. A high-speed rotor inside the chamber is fitted with swinging hammers made from hardened steel, which hit dried root crops at high speed and throw the pieces against the beater bars. They then bounce back into the path of the hammers and are disintegrated. The fineness of the flour is controlled by the size of the holes in the screen (smaller holes produce finer flour). If a screen with larger holes is used, the hammers produce fine particles, but larger particles also pass through the screen to produce coarser and darker flour. The size of holes in the screen also determines the output from the mill (larger holes give a higher output).



Fig. 5.14 Hammer mill

The following details of maintenance of mills were provided by Patrick Tibasiimwa and were first published in 'Opportunities in Milling and Baking', by P. Fellows and B. Axtell, CTA, 2003 (Annex A). A summary of maintenance requirements is given in Table 5.3

Table 5.3 Details of routine mill maintenance

Daily Maintenance	<p>Mechanical</p> <ul style="list-style-type: none"> ✓ check and grease bearings, replace if faulty ✓ check pulley wheels for cracks or chips and replace if necessary to avoid damaging belts. ✓ check bolts & nuts for tightness. ✓ check the oil level in diesel engines and top up with the correct oil if required.
	<p>Electrical</p> <ul style="list-style-type: none"> ✓ clean flour dust off motors and other electrical equipment ✓ when a machine is not in use, make sure that power is switched off at the mains and that equipment has not been left switched on. This is very important when power cuts occur, because when power returns a machine that has been left on can injure an operator or cause a fire.
	<p>Housekeeping</p> <ul style="list-style-type: none"> ✓ store tools and equipment in pre-determined places to help find them next time and to help notice when they have gone missing. ✓ always keep walkways clear of tools and equipment ✓ clean diesel engine cooling fins every day to prevent dust settling and causing the engine to overheat and eventually seize ✓ when re-fuelling diesel engines, pour the fuel through a filter to prevent rust deposits in the fuel drum getting mixed with the fuel and damaging the engine ✓ clean the machinery and floor
Weekly maintenance	<ul style="list-style-type: none"> ✓ check hammers for wear and replace if necessary ✓ check the shaft (especially if locally manufactured machines are not tested for strength or alignment) ✓ check that locking nuts on the shaft are tight. ✓ check that fan bolts and nuts have not loosened as the fan then becomes very dangerous. ✓ check the bearing mountings as this area is prone to cracking ✓ check the engine oil and oil filter on diesel engines and change them every 160 working hours. Change the fuel filter every 320 working hours.
Monthly maintenance	<ul style="list-style-type: none"> ✓ check the body casting and welds for cracks ✓ tighten floor nuts and look for any cracks in the mill foundation ✓ check the fan key and make sure that the fan is a slide fit on the shaft for easy removal. If the blades are worn always replace with the correct thickness of steel and then check for balance ✓ check that cables are secured and there is no obvious sign of insulation breakdown ✓ check the acid level in batteries that are used to start diesel engines. Keep the terminals clean.

If a hammer mill fails to grind efficiently the hammers may be badly worn, and they should be first turned around to use the second edge (Fig. 5.14). When this has worn the hammers

should be replaced. Hammers should also be checked for elongation of the fixing holes and worn pins. If the holes are worn it can cause the hammer to hit the screen and damage it. If worn pins are not replaced, they eventually fail causing the hammer to fly off and cause considerable damage to the screen and other parts inside the mill.

Fig. 5.15 **A)** New hammer and **B)** Worn hammer from a hammer mill. (P.Tibasiimwa)

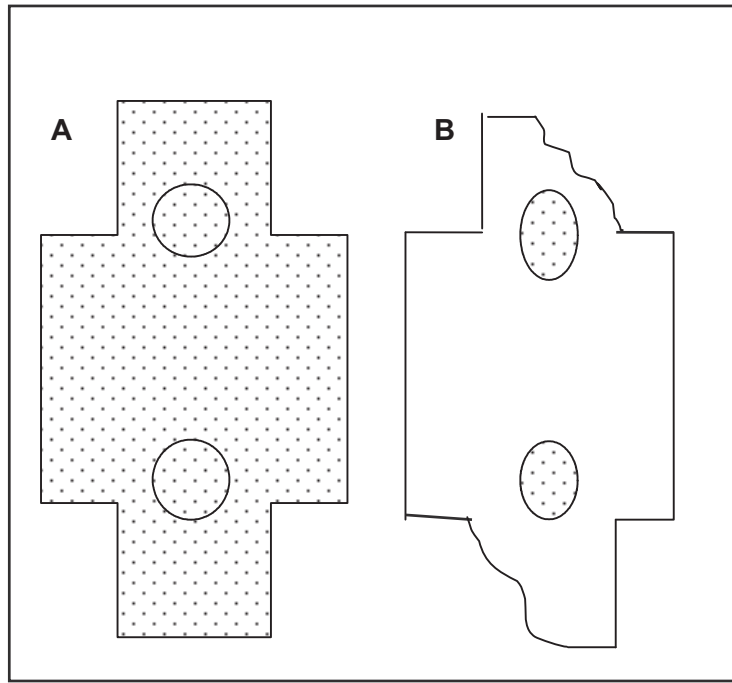

When fitting new hammers ensure that they are the same length and the holes are in the same position as the old ones. Hammers should also be checked to ensure that they are the same weight, and are balanced in matching pairs so that the machine runs smoothly without vibration. A simple balance can be made for checking the weight of pairs of hammers (Fig 5.15).

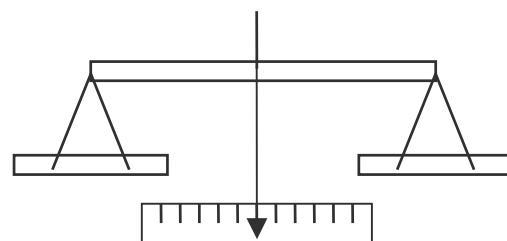

Fig. 5.16. Balance to check the weight of hammers
(Note: The pointer should hang vertically when there are no hammers on the balance.)

If a hammer mill continues to vibrate after the hammers and bearings have been checked, make sure that the distances from the spindle to each hammer pin hole are equal. If they are not equal, they must be corrected by filling the holes with weld and re-drilling them. The rotor must then be re-balanced. A simple method to balance the rotor is to use two angle bars set on the edge of two benches. The angle bars must be straight and set level with a spirit level. The pulley, bearings, keys, hammer pins and fan should be removed from the shaft before balancing. The rotor is rolled along the angle bars and where it stops the top is marked with chalk. The heaviest part is always underneath when the rotor stops moving. The procedure

is repeated several times and the chalk marks are checked for closeness to indicate consistent results. The weight of the rotor at the top is then increased by dropping weld onto the outer edge.

Alignment of pulleys and V-belts

Mills and hullers are usually driven by belts that connect the motor to the mill. These come in five sizes (A – E), but ‘B-section’ or ‘C-section’ belts are most commonly used on small mills or hullers (Table 5.4). Pulleys and belts should be as short as possible and fully covered with guards. It is important that drive pulleys and V-belts are exactly aligned, in order to reduce wear on the belts and to transmit maximum power to the machine. It is the sides of V-belts (not the bottom) that lock into the pulley and grip it. To achieve maximum belt life and power transmission, the pulleys must be exactly at 90° to the belts and the belts must fit correctly into the pulley grooves. V-belts are tensioned to drive the mill, and when measured at the centre of the belt span, there should be a 16mm deflection per metre of belt (measured from a straight edge placed across the pulleys). Tensioning increases the load on the bearings of both the mill and the motor. If a belt heats up there is a problem with the tension, and it is therefore essential that belts are tensioned to the correct amount. Dust is one of the main causes of damage to V-belts and they should therefore be cleaned daily.

Table 5.4. Number of belts for mills of different power requirements

Power of mill motor (HP)	‘B’ Section belt	Power of mill motor (HP)	‘C’ Section belt
0-7	1 belt	0-9	1 belt
7-14	2 belts	9-18	2 belts
14-21	3 belts	18-27	3 belts
21-28	4 belts	27- 36	4 belts

(HP = Horsepower, 1HP = 0.745 KW. Minimum ‘B’ pulley diameter 115mm, Minimum ‘C’ Pulley diameter 175mm)

Checking the operation of a mill

Properly dried root crop chips mill faster, requires less energy (hence lower power costs), creates less wear on the mill and huller and so reduce maintenance costs. The efficiency of the mill depends upon the following factors:

- distance from screen to hammers
- speed of rotor
- suction of fan
- flow of flour from the mill to cyclone
- correct design of cyclone to minimise flour losses.

Distance from screen to hammers

The distance between the hammers and the screen should be as small as possible. If there is a large gap, little or no flour will pass through and the output of the mill is reduced. Hammers should be 4-6 mm from the casing. If the gap is larger, power is wasted because flour will build up on the screen, giving a lower output and greater wear on both hammer and rotor plates. Wider hammers have slightly better efficiency than thin hammers.

Speed of rotor

The speed of rotation is critical for efficient operation of the mill, and can be found using Table 5.5 by measuring the distance between the furthest points on the hammers when assembled on the rotor with the hammers at their maximum extension. Alternatively, the speed of the rotor can be calculated from the motor speed use the following formula:

$$\text{Rotor speed (rpm)} = \frac{\text{Motor pulley diameter (mm)} \times \text{Motor speed (rpm)}}{\text{Mill pulley diameter (mm)}}$$

Table 5.5. Optimum rotor speeds for different sized hammers in a hammer mill

Distance of hammers (mm)	Optimum Speed of rotor (rpm)	Distance of hammers (mm)	Optimum Speed of rotor (rpm)
300	5100	525	2910
325	4700	550	2780
350	4365	575	2660
375	4075	600	2550
400	3800	625	2440
425	3600	650	2350
450	3400	675	2260
475	3220	700	2180
500	3060		

(Note : An allowance of plus or minus 15 % can be made on these figures).

Fault finding

During operation of the mill, stop and investigate immediately if anything unusual is noticed with the mill or its performance, for example:

- Vibration
- Excessive heating of bearings, pulleys or belts
- Unusual noises
- Loose nuts and bolts
- Damp chips causing a blockage.

In order to solve a problem it is necessary to first identify the real cause. For example if a blown fuse is the problem, but bare wires touching the roof is the real cause, no matter how many times you replace the fuse it will not stop the wires touching on the roof. Some examples of faults in a hammer mill and possible causes are given in Table 5.6. Similar considerations apply to other types of milling equipment.

Table 5.6. Checking for faults in milling equipment

Fault	Check
Motor stops running	<ul style="list-style-type: none"> • if power is there at the correct voltage • for a burned smell from motor • for burning of electrical cables • if the isolation system is working (have fuses blown?) • if the motor can run without the mill • where there is more than one machine, check the other to see if it is working • if neighbours' machines are working
Motor running but blows fuse	<ul style="list-style-type: none"> • that the load is below the rated load. • if the fuse is the correct size • insulation resistance of cables and motor windings
Motor running but blows fuse when under load	<ul style="list-style-type: none"> • if motor is overloaded • for correct feedrate into the mill • if connections on the motor are satisfactory • that the fuse rating is correct
Motor develops unusual noise	<ul style="list-style-type: none"> • for loose fan cover on the motor • for worn bearings • starter • power supply (are all phases operating?) • for loose connections at main switches
Motor smoking	<ul style="list-style-type: none"> • if varnish on motor windings is intact • for worn bearings • starter • for loose connections • for burnt out motor
Motor over-heating	<ul style="list-style-type: none"> • bearings • starter • for correct loading on the motor • motor wiring • motor rating • if fan is working • maintenance book (is motor due for service?) • power supply • that alignment of pulleys/belts is correct • grease (is the quantity and quality correct?)
Vibration of the mill	<ul style="list-style-type: none"> • if bearings are worn • if there is a loose fan, rotor or pulley • if shaft has bent • if hammers are unbalanced, loose, broken or wrong type • for wrong type of bearings
Bearings overheating	<ul style="list-style-type: none"> • that bearing grease is correct type and quantity • for bearing alignment • the load on the rotor • that bearings are the right type

Overheating belts	<ul style="list-style-type: none"> • for incorrect pulley size or depth of v-belt • for over tensioned belts • if belts have become mis-aligned • that pulley diameter is not too small • that there are not too few belts to drive the mill
Unusual noise	<ul style="list-style-type: none"> • if hammers are hitting screen or casing • for broken hammer pins • for foreign object inside mill

Motors/isolators/starters

A qualified electrician should wire electric motors. Motors should not be wired directly to 13 amp sockets and a starter and isolator should be fitted. When used, V-belts should be tightened to permit a maximum of 2cm sideways movement at the centre of the belt. There are no routine maintenance requirements, except to check that wiring remains properly connected and does not work loose because of vibration. Motors, starters and isolators should be kept clean and the external surfaces should be wiped down weekly.

**Always ensure that a motor is isolated from the mains before touching it for any reason.
Do not use water to wash any electrical equipment.**

Peelers

Irregular shaped root crops are usually peeled by hand. More uniform root crops, such as Irish potatoes, can be peeled using mechanised peelers that consist of a rotating chamber that is lined with an abrasive material such as carborundum. Chemical peeling using sodium hydroxide (lye) is not recommended. Peeling machines have no maintenance requirement apart from periodic sharpening of the blade. They should be washed with detergent after use and rinsed with clean water.

pH meters

Small hand-held pH meters are suitable for process control in jam making, but they are relatively expensive. They should be calibrated against buffer solutions that are supplied with the instrument, and also calibrated for the ambient temperature. pH can also be measured using pH papers, which are cheaper but less accurate than meters.

Pot & bottle sealers/cappers

Twist-on-twist-off (TOTO) caps and plastic caps are usually fitted by hand. Small machines are available to seal Roll-On-Pilfer-Proof (ROPP) caps onto jars. The sealers and cappers do not require spares or routine maintenance and should be kept clean by wiping them with a damp cloth after use.

Presses

Manual presses are used to press cassava pulp during manufacture of gari. They can be made from parallel plates that are moved together to press sacks of pulp using either screw threads or a hydraulic jack. Alternatively, a cage press has a perforated cylinder in which pulp is pressed using a screw or jack.

Fig 5.17 Cassava press



Pressure cookers

These heat foods to either 110°C or 120°C, depending on the setting of the pressure valve. Foods are placed in the pan and the lid is securely sealed. The pressure valve is placed on the pipe in the lid, following the manufacturer's instructions to set the required position. The pan is heated until steam escapes from the pressure valve and the heat is then reduced to maintain this pressure. If steam emerges from under the lid, immediately remove the pan from the heat and when cool, replace the gasket seal around the lid.

**It is dangerous to use a pressure cooker with a faulty seal.
There is a risk of an explosion and injury!**

The pressure cooker is cleaned with detergent and a brush, and rinsed with clean water. A spare gasket should be kept and the gasket should be checked monthly for signs of damage.

Protective gloves, hats, hairnets, coats, boots

Gloves and boots should be washed daily using detergent and rinsed with clean water. Depending on the amount of soiling, coats should be cleaned either daily or weekly at a laundry. Hats and hairnets should be cleaned as required.

Refractometers

A refractometer measures sugar concentration as °Brix, which corresponds to % sugar. The instrument range for jams is 40-80° Brix. Some manufacturers also now supply a single range instrument (0-80° or 0-90° Brix). They are expensive instruments but they give an accurate measurement of sugar concentration. There is no maintenance requirement and the instrument is cleaned after use by wiping the glass with a clean cloth and rinsing it with distilled water.

Fig 5.18 Refractometer



Roasters

Gari is roasted in an open pan at micro-scale production. At larger scales of operation, a horizontal steel drum containing the gari is rotated over a fire. The drum is fitted internally with paddles that mix the gari to prevent localised burning. There is no maintenance requirement and they should be wiped or brushed clean after use.

Sack stitchers

The machines sew paper or thick polythene sacks (minimum 120 μ) to seal them.

The mechanism will carry the sack through the machine and it should not be pulled or pushed.

There should be sufficient free space between the top of the product in the bag and the sewing line to have enough material to sew. A minimum of 5 cm is needed for paper bags and 10 cm for jute or netting bags.

Do not change the settings of internal components – these are set at the factory and changing them could damage the machine

Use of the stitcher:

1. Form a gusset in the top of the bag/sack. Fold the top over as close as possible to the product and then bring it to a vertical position for sewing
2. Take the top right side of the bag in the left hand and feed it between the presser foot and the throat plate
3. Press the switch to start the machine (the bag is carried through the sewing gap by the feed mechanism)
4. Support the bag as it feeds through the machine to achieve a straight seam
5. When the bag is sewn, let the machine run on to create a short 'chain' of thread and gently turn the machine to the left to allow the knives to cut the thread



Fig. 5.19 Sack stitcher

Keep hands and fingers away from the moving parts (the needle, feed dog and presser foot)

Maintenance

Fitting a new needle:

1. Unplug the machine and place it with the handle flat on the table so that you are looking at the looper cavity and the needle guard
2. Remove the pulley guard
3. Raise the presser foot and rotate the machine manually until the needle is at its highest position.
4. The needle is held in the needle bar by a nut. Loosen the nut with a 3/8 open ended wrench (provided). Do not use pliers.
5. Place the new needle in the needle bar, making sure that it is fully inserted and that the long groove faces you, with the needle scarf to the back. The groove lips should match the base of the machine and the eye should face you.
6. Tighten the nut to clamp the needle in place. Do not use excessive force.
7. Lower the presser foot and check to see that the needle is passing through the middle of the needle guard
8. Replace the pulley guard and re-thread the machine.

Threading the needle:

1. Pass the thread through 1st and 2nd eyelets and around the tensioning stud between the two tensioning discs.
2. Pass it through the 3rd eyelet close to the needle guard
3. Pass it through the slotted opening in the needle guard, through the needle and then through the opposite side of the needle guide
4. Push the thread through the eyelet to reach the front of the needle
5. Push the thread through the needle eye from the front and pull about 8 cm of thread through
6. Test the machine on an empty bag.

Fitting a new cone of thread:

1. Unscrew the wing nut at the base of the thread stand
2. Remove the thread clamping bolt
3. Take a new cone, place it on the clamping bolt and put it on the thread stand
4. Re-attach the wing nut and tighten it. The cone should not rotate or wobble on the stand.

Thread tension adjustment:

The outer nut on the tensioning discs is a locking nut and the inner one is to adjust the tension. Turning the tensioning nut clockwise increases the tension and turning it anticlockwise reduces the tension on the thread. Start with minimum tension and examine the stitch. If it is too loose, gradually tighten the tension nut until a proper stitch is obtained. Lock the nut in position.

Replacing the drive belt

1. Unplug the machine and remove the thread cone holder
2. Remove the handle by unscrewing 2 screws
3. Loosen the 2 screws on the motor mounting

4. Press the motor mount closed to give slack to remove the old belt and fit a new one around both pulleys
5. Apply tension to the belt by opening the motor hinged mounting bracket and tightening the two screws. The belt should have 3-4mm play at the centre.
6. Re-attach the handle and cone thread holder.

Daily maintenance

1. Press the oil pump button 2-3 times while the machine is running until you see oil flowing through the feeder tube. This should be done every 2 hours of machine use.

If the wick that carries the oil becomes worn or thin replace it immediately to avoid damage to the machine

2. Check the level of the oil pump, always replacing the cap to prevent oil lines becoming contaminated with dust and getting blocked
3. Remove any dust with a brush – especially around the bottom of the machine, the looper and the knives

If cleaning is done daily it will increase the life of the machine

Always disconnect the machine before cleaning or maintenance

Weekly maintenance:

1. Check the motor brushes to ensure that they are more than 6mm long. Replace if they are shorter than this, by lifting out the brush holders and fitting new brushes
2. Clean the machine in an oil bath by filling a small tank to 6cm deep with cleaning oil
3. Remove the looper cover at the bottom of the machine and the belt/pulley cover and handle
4. Plunge the machine vertically into the oil bath so that it is immersed to the level of the throat plate
5. Turn the machine manually at the pulley so that moving parts are cleaned by the oil
6. Remove and allow excess oil to drain back into the tank
7. If necessary, loosen stubborn dirt with a brush and re-immerses the machine.
8. Clean the outside with a small oiled brush, wipe clean with a soft absorbent cloth

Never use solvents to clean the machine

Scales

Small scales (0-2kg) have been supplied by UNIDO to weigh out small amounts of ingredients or laboratory chemicals, and larger scales (0-50kg) for weighing root crops. **Care is needed to properly clean scales if they have been used to weigh chemicals before using them again for food.** The small scales can be operated using batteries or mains power. The large scales should be hung from a door lintel. Calibrated scoops, cups or other measures, which contain the correct quantity of an ingredient when filled level with the top, can also be used instead of scales. Operators should be trained to ensure that they use them properly to measure consistent weights. The scales have no spare parts or routine maintenance. They should be cleaned after use using a damp cloth.

Sulphuring cabinet

A cabinet can be made from wood, covered in either plywood or polythene and fitted with mesh trays to hold the sliced crop. The cabinet can be either lifted off the stack of trays for loading/unloading or it can be fitted with a sealable door. The aim is to retain sulphur dioxide gas from burning sulphur inside the cabinet so that it can penetrate the slices. There are no spare parts or routine maintenance. Trays are cleaned after use with a brush and detergent, rinsed with clean water, and properly dried in the sun before re-use.

Checklist 5

Can you answer these questions? Tick the box if you know the answer. Write notes on what you currently do or need to do to find the answer.

Question	Tick	Notes
1. Do you know where to obtain the following equipment?		
Bagging machine		
Blanchers		
Boiling pans		
Bottle coolers		
Chippers/slicers		
Deep fat fryers		
Dicers		
Dryers		
General tools, work tables		
Graters		
Jam thermometers		
Labellers		
Laboratory glassware and equipment		
Mills		
Motors/Motor isolators/Motor starters		
Packing tables		
Pasteurising kettles		
Peelers		
pH meters		
Presses		
Protective gloves, hats, hairnets, coats, boots		
Refractometers		
Roasters		
Sack stitcher		
Scales		
Sealers		
Sulphuring cabinets		
2. Do you know where to get spares for the above equipment?		

6 Quality Assurance

All root crop and tuber products should have a marketable quality and also be safe for consumers to eat. Even at the smallest scale of production, the processor should develop a Quality Assurance (QA) system to ensure this. The following steps are needed to develop a system:

1. Look at every stage of the process, from raw material selection to distribution of products, and identify the factors that could affect either product quality or safety.
2. Develop procedures to monitor and control these factors so that they do not cause a problem

The basis of QA is to prevent problems from arising, rather than trying to cure them afterwards. The stages in a process where an error could affect the safety of a product are known as Critical Control Points (or CCPs) and these are the stages that should be given most attention. Any sources of contamination from buildings or water supplies should be included.

It is important to train all staff to operate the QA procedures that are devised. They should know the limits that are put on any variations from the required processing methods. Everyone should understand their responsibilities for ensuring that high quality products are made. The more staff that examine the raw materials, process and product, the greater the level of control. It is also important to develop reporting procedures and keep records. There should be a plan of what must be done if the process limits are exceeded. Workers should know who has the authority to make decisions and who is responsible for checking that the correct action is taken.

UNBS can assist small businesses to implement QA schemes. This type of assistance could also be organised by the Cottage Scale Food Processors' Association. If a processor is thinking of exporting their products, importers will require both a QA system and a HACCP programme. Importing countries may have additional legal requirements on contents and ingredients, labelling, packaging, sanitation, inspections and so forth. The importers or their agent should be consulted to find out in detail what is required.

Worked example 8: Establishing a QA/CCP system

In the production of dried cassava chips, the stages in the process and factors to consider are shown as follows:

Inspect	<u>CCP</u> – Remove all mouldy, rotten, badly damaged raw materials and foreign matter that can contaminate the finished product or damage expensive equipment.
Wash	<u>CCP</u> – Water must be potable and clean. Check that crops are clean (extraneous matter could contaminate product). Replace dirty water.
Sort/grade	Check that no inedible parts are present. <u>CCP</u> - A limit of zero insects or mouldy roots (moulds could affect flavour and shelf life of product),
Peel	Check that all traces of peel are removed.
Slice	Check for correct thickness and uniform sized pieces.
Blanch	<u>CCP</u> . Check water temperature and time of heating.
Dry	<u>CCP</u> . Check temperature and time of drying, check final moisture content, check for mould growth and insect contamination
Label	Check that label is correct for type of product and properly aligned. Replace misaligned or incorrect labels
Store	Store in a cool dry place away from sunlight. Protect from crushing. Modify storeroom if too hot or damp

Once the factors that affect the quality and safety of the product are identified, steps can be taken to monitor and control them as follows:

Raw materials

The first inspection of crops at the processing unit should include checks on visible mould or rots, serious bruising or cuts, and the presence of large amounts of soil, leaves or other materials. Root crops are easily damaged by poor handling practices and this allows moulds and rotting bacteria to grow on them. Damage to a few roots can quickly lead to infection of others and the loss of a whole batch. Handlers should be asked to cut their fingernails to prevent them puncturing roots, the crops should be cooled after harvest and stored in a cool place or covered with wet sacks, and any damaged roots should be removed to prevent spoilage of surrounding foods

Crops are washed in clean water, and processing staff should be trained to remove any rotten pieces because these can quickly contaminate the wash-water and infect good quality raw materials. Careful inspection by trained staff is important for saving time and money later in the process. Poor quality raw materials produce poor quality final products because it is not possible to improve their quality by processing them.

Sorting out substandard materials before money is spent processing them is one of the most cost effective methods of ensuring a uniformly high quality in the final product.

Processing, packaging and storage

Value is added to raw materials at each stage of processing and by the time a product is packaged it has gained most of its final value. Any losses at this stage are therefore the most serious, causing the greatest financial loss to the processor. The QA system should ensure that products are stored off the floor in a cool, dark storeroom that has good ventilation and protection against insects and rodents. QA systems should also monitor the time that they remain in storage. Records should show which materials are transferred into and out of the storeroom and when they are used or sold. A First In/First Out (FIFO) system of stock control should be used. It should apply to raw materials, other ingredients and finished products. Processors should also monitor and control distribution to retailers and storage/display in retail outlets.

Testing products and packaging

The methods for process control described below are each relatively simple and have sufficient accuracy for routine use. Most do not need sophisticated or expensive equipment or high levels of skill. However, many are comparative methods and the results can only be compared with other results obtained by the same method. This is acceptable for routine process control, provided that careful attention is paid to ensuring that exactly the same method is followed each time.

Acidity

It is necessary to check the pH of sweet potato jam. pH is a measure of acidity (see glossary in Annex B), which can be measured by dipping a piece of pH paper into a sample of liquid food and comparing the colour change with a chart supplied with the paper. For greater accuracy a hand-held pH meter can be used.

Moisture content

Finely chopped samples are carefully dried in an oven at 100°C and reweighed. They are put back into the oven and checked again at hourly intervals until they do not lose any more weight. The moisture content is calculated using the following formula:

$$\% \text{ moisture} = \frac{\text{Initial weight of sample} - \text{Final weight of sample}}{\text{Initial weight of sample}} \times 100$$

The % solids content = 100 - % moisture content

Packaging

Bottles and jars for sweet potato jam are checked more than other types of packaging because of the risk of glass getting into a product, which would seriously harm consumers. They should be checked for splinters, cracks, bubbles in the glass, or strings of glass across the interior. Staff who check bottles or jars should be fully trained to recognise these faults and they should only inspect them for 30 minutes at a time to maintain their concentration. If jars or bottles are re-used, they should be checked for residues by smelling them. It is also necessary to check the weights of a number of empty jars or bottles to find the heaviest. This is then used to calculate the checkweight for that product (the weight of the heaviest container plus the weight of product). The fill-weight should be the same as the net weight

described on the label, and random sample of packs should be checked to ensure the correct net weight using scales.

A simple gauge (Fig 6.1) can be made to check that the product has been filled to the correct level. It is placed on the rim of the container and the level where the product touches one of the prongs is read off. Glass containers are also checked if there is a problem with poorly fitting caps. The diameter at the neck is measured using *go/no-go rings* that show whether the neck diameter is too large or too small for the lid, or whether the neck is circular or oval.

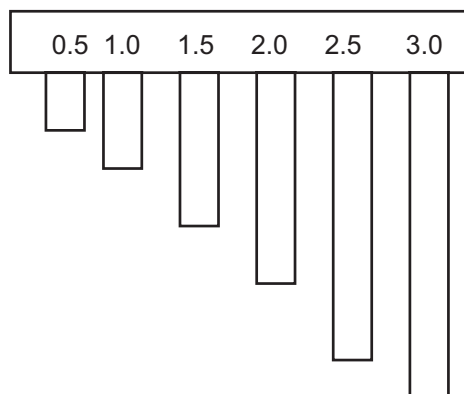

Figure 6.1. Headspace gauge

Typical faults with plastic bags include incorrect printing, smell of solvents used in their manufacture, film sticking together, poor seal strength and incorrect thickness. The last can be measured by cutting 10 squares of film, each 10 cm by 10 cm and carefully weighing them. The result (in grams/square metre) is then checked against the suppliers' specification.

Sugar

A hand-held refractometer can be used to check sugar concentration during the final boiling of sweet potato jam. The sugar content can also be assessed using a 'jam thermometer' that reads up to 120°C. The sugar content is 68-72% when the temperature reaches 104-105°C at sea level. However, staff should have experience of making the product before using temperature alone to control the process. The boiling point changes with height above sea level, and in Uganda, producers should first check the boiling point of water and make the necessary corrections. With experience, staff can also estimate the solids content of the jam by cooling a sample of the boiling mixture and noting the texture to see if a firm gel forms.

Checklist 6

Can you answer the following questions? Tick the box if you know the answer. Write notes on what you currently do or need to do to find the answer.

Question	Tick	Notes
1. Do you have a QA programme for your products?		
2. Do you have schedules for routine inspection and cleaning of the processing unit?		
3. Does your processing room meet legal requirements for hygiene and sanitation?		
4. Do you know how to test your products?		
5. Do you know how to check your packaging?		
6. Do your products meet legal requirements for product specification and standards?		
7. Do your products meet legal requirements for fill-weight and label design/information?		

7

Summary of Legislation and Regulation

International

Global efforts to establish and improve consumer health protection have led to increased governmental and regulatory oversight in the field of food safety. While most people presume the foods they eat are safe, several recent food safety events have eroded this confidence and led to demands from the public for additional protective measures to be enacted to establish the rights of consumers to safe food. The scope of this protection has expanded beyond the practices of the food manufacturers and now extends all the way back to the farm gate. It is essential that safety be embodied in food products from production through consumption, from the farm to the table (food chain approach). All stakeholders in the food chain, including the supply side (producers, transporters, processors, and merchants), the government inspection and regulatory authorities, the support institutions (labs, R&D and training centres), and consumers will now have responsibilities and obligations to ensure the safety of food products and protect consumer health.

For enforcement purposes, the Codex Commission has developed several guidelines and food standards. There are today approximately 250 standards and specific requirements for individual foods, groups of foods, and other provisions, e.g., hygiene, contaminants, labelling, and food additives.

Enforcement of food control has evolved from the traditional focus on inspection of final products and removal of unsafe food from the market to the current holistic and preventive approach, which relies more on system control. In addition to the traditional GMP (or GHP), formalized control operations relying on hazard analysis and risk prevention have been made mandatory in the main markets. This systematic approach to the identification, assessment, and control of hazards is known as the Hazard Analysis and Critical Control Point (HACCP) system.

The introduction of a HACCP-based food safety system may be difficult for small-scale enterprises and will be best achieved by coordination between the food industry, educational and training organisations, and governing authorities. There are various guides and training information on the introduction and application of HACCP in the food chain.

Uganda

At the time of the preparation of this manual in 2004, the Government of Uganda was in the process of developing the National Food Safety Strategic Plan. The Parliament was also debating a draft Food Safety Bill. Once enacted, the “Food Law” or the “Food Safety Law” will contain provisions for the mandatory implementation of GMP and/or HACCP programmes within the food chain. This law was proposed to develop an effective national food safety control system to protect the health and wellbeing of consumers, as well as, meeting international standards and requirements for the trade of food products

There are various laws governing the setting up, registration and operation of a food processing enterprise in Uganda. Failure to follow the law may lead to punishment by the authorities or closure of the business. Processors should check the local laws with the UNBS.

In summary the registration of a mill or food processing facility involves the following:

- Registration of the enterprise with the Ministry of Trade and Industry
- Obtaining a Certificate of Share Capital (for limited companies), or a Certificate of Incorporation (for corporate companies)
- Obtaining an Occupational Certificate from the Local Authority or the Planning Authority in the Land Ministry
- Obtaining a Health Permit or Licence from the Local Authority or Ministry of Health to allow the premises to be used for food production
- Obtaining a Manufacturing Licence, issued by the Local Authority
- Obtaining Medical Certificates from the Health Authority to certify that workers are fit to handle food
- Registration with the Revenue Office.

Hygiene and sanitation

Together, a manager and processing staff should develop a cleaning plan and personal hygiene rules to ensure product safety. If a member of staff reports a stomach illness or skin infection, he/she should be transferred to jobs that do not involve handling the product. There should also be proper cleaning materials and equipment available and adequate time set aside for cleaning machinery and processing areas after production has finished.

**All food production facilities must comply with the
Code of Practice for Hygiene in the Food and Drink Manufacturing Industry, US 28:2001.**

Food composition

There are four types of general laws in Uganda that govern the sale of all goods, including root crop products. These state that:

1. The product should be suitable for its intended purpose
2. It is an offence for anyone to add anything to food, to process it or to sell food for human consumption if it harms consumers' health
3. To protect customers from adulteration of foods or other forms of cheating, it is an offence to sell food that is not of the nature, substance or quality demanded by the purchaser
4. It is an offence to falsely describe a food on the label or in advertising, with the intention of misleading the customer.

There are also laws that deal with the safety of foods, the hygiene of operators and sanitation of premises where foods are made. In summary the laws are concerned with the following aspects of health, hygiene and sanitation:

- Processing that is carried out in unsanitary conditions or where food is exposed to the risk of contamination
- Equipment (which must be able to be cleaned and kept clean)
- Persons handling food and their responsibilities to protect it from contamination
- Building design and construction including water supplies, drainage, toilet facilities, wash-hand basins, provision of first aid facilities, places to store clothing, facilities for washing food and equipment, lighting, ventilation, protection against infestation by rats and insects and removal of wastes.

If in doubt, entrepreneurs should seek advice from staff at UNBS, from food technologists at Makerere University Dept. of Food science and Technology or UIRI.

Standards

In relation to root crop and tuber products, the following compositional standards are in force in Uganda:

Additives and contaminants

There are lists of permitted food colours, emulsifiers, stabilisers, preservatives and other additives that can be added to foods. Any chemical that is not on these lists cannot be used. There are also maximum levels set for each additive in specific foods and lists of foods that are able to contain specified preservatives. Contaminants, including poisonous metals such as arsenic and lead, have maximum permitted levels in specified foods.

Food labelling

It is in the processors' interest to involve UNBS at an early stage of label design to avoid problems with prosecution and expensive re-design after labels have been printed. The UNBS has a 'General Standard for the labelling of pre-packed foods' (US7:2002 that describes the information that must be included on a label, but there are also detailed laws concerning the following aspects:

- Specify names that must be given to different types of ingredients
- Ingredients that are exempt from the law
- The use of words such as *best before* and *sell by*
- Locations of the name of the food, the sell-by date and the net weight (they must all be in the same field of vision when a customer looks at the label)
- The visibility of information and the ability of customers to understand it (including the relative print sizes of different information)
- Claims and misleading descriptions, especially about health-giving or tonic properties, nutritional advantages, diabetic or other medicinal claims
- Specifications of the way in which certain words such as *flavour*, *fresh*, *vitamin* etc. Can be used.

This is also a complex area, which is not possible to describe in detail in this book and professional advice should be sought from graphic designers who are experienced in label design, or from the Bureau of Standards. The legal requirements for label information in Uganda are as follows:

- Name and address of the producer
- Name of the product
- List of ingredients (in descending order of weight)
- Net weight of product in the package
- A 'use-by' or 'sell-by' date.

In addition, a processor may include:

- Instructions for preparing the product
- Storage information or instructions on storage after opening
- Examples of recipes in which the product can be used
- An 'e-number' if export to Europe is contemplated
- A bar code.

The laws are to ensure that the amount of food that is declared on the label as the net weight (the weight of product in a pack) is the same as the weight of food that is actually in the pack. The weights and measures legislation in force in Uganda is known as the 'Minimum Weight System'. This ensures that every pack of food contains at least the net weight that is written on the label. If any pack is found below this weight the producer is liable for prosecution.

Water

Only potable water may be used in food operations. Potable water is drinking water that is wholesome and clean and does not cause illness. It is free from any micro-organisms and parasites and from any substances that in numbers and concentrations, constitute a potential danger to human health. It should meet standard US 201:1994 as established by UNBS.

Summary

To achieve optimum consumer protection, it is essential that safety be incorporated in food products from production through consumption. All participants in the food chain from the primary producer to the processor to the vendor to the consumer play vital roles in ensuring food safety. Each has different responsibilities, but all must work together in an integrated farm-to-table approach.

Checklist 7

Can you answer these questions? Tick the box if you know the answer. Write notes on what you currently do or need to do to find the answer.

Question	Tick	Notes
1. Do your products meet legal requirements and US standards for product specification?		
2. Do your products meet legal requirements for fill-weight and label design and information?		
3. Do you know the basic requirements of the new Food Safety Law and how it impacts your business?		

Annex A: Sources of further information and assistance

The following organisations may be able to help solve specific problems, offer advice or information:

- Action Aid, 2514 Gaba Rd, Kampala, T: 266640
- ADC (Agribusiness Development Centre), PO Box 7856, 18 Prince Charles Drive, Kololo Kampala, T: 255482/83/68, F: 250360, E-mail: adc@starcom.co.ug
- AEATRI (Agricultural Engineering and Appropriate Technology Research Institute), PO Box 7144, Kampala, Email: aeatri@starcom.co.ug
- Aga Khan Foundation, 4 Parliament Ave, Kampala, T: 256165/ 255884
- ATI (Appropriate Technology International), 22a Namirembe Rd, Kampala, T: 349147
- Austrian Development Corporation, 6 Entebbe Rd, Kampala, T: 233002
- DIFD (Department for International Development - UK Govt), PO Box 7070, Rwenzori Building, Kampala, T: 348731/33, F: 348732, E-mail: info@dfid.gov.uk
- Department of Industrial Art and Design, Makerere University, PO Box 7062, Makerere Kampala, T: 531423, E-mail: fineart@imul.com
- DFST (Department of Food Science and Technology), Makerere University, PO Box 7062, Kampala, T/F: 533676, E-mail: foodtech@infocom.co.ug
- Department of Food Science, Uganda Polytechnic Kyambogo, PO Box 26486, Kampala, T: 285211
- Department of Home Economics, ITEK (Institute of Teacher Education, Kyambogo), PO Box 1 Kyambogo, Kampala, T: 285001/2, F: 220464, E-mail: itek@starcom.co.ug
- European Development Fund - Microprojects Programme, 24b Lumumba Ave, Kampala, T: 230033/ 35, 254613, 232487
- FAO (Food and Agriculture Organisation), 72 Buganda Rd, Kampala,
- FIT Programme, P. O. Box 24060, Kampala, T: 221785, F: 221038, Email: fituga@imul.com
- FOSRI (Food Science and Technology Research Institute, part of NARO), PO Box 7852, Plot M217, Nakawa Industrial Area, Jinja Rd, Kampala, T: 222657/285248/077 594980, F: 222657, E-mail: fosri@imul.com
- Gatsby Trust, Faculty of Technology, Makerere University, PO Box 7062, T: 531048/545029, 077 408762, F: 542377, e-mail: gatsby@techmuk.ac.ug
- German Development Services, 1773 Muyenga, Tank Hill, Kampala, T: 268662/0
- KARI (Kawanda Agricultural Research Institute), PO Box 7065, Kampala, E-mail: karidir@starcom.co.ug
- IITA (International Institute for Tropical Agriculture), Marketing & Post Harvest Research East & Central Africa, PO Box 7878, Bandali Rise, Bugolobi, Kampala, T: 220217/077 472103, F: 23460, 223459, E-mail: foodnet@imul.com
- MAAIF (Ministry of Agriculture, Animal Industries and Forestry), PO Box 102, Berkeley Lane, Entebbe, T: 20980/3/8
- Midway Centre, c/o MTAC (Management Training & Advisory Centre), PO BOX 24050 Jinja Road, Nakawa, Kampala, T/F: 223505, E-mail: midway@imul.com
- Ministry of Health, PO Box 8, Entebbe, T: 20209/0, F: 20474
- MUBS (Makerere University Business School, Business Development Centre), PO Box 1337, New Port Bell Rd, Kampala, T: 223859, F: 221682, Email: commerce@starcom.co.ug, commerce@infocom.co.ug

- NAARI (Agriculture and Animal Production Research Institute), PO Box 7084, Namulonge, E-mail: naari@naro.bushnet.net
- NARO (National Agricultural Research Organisation, Kawanda), Post Harvest Research Programme, Kawanda Agricultural Research Institute, PO Box 7065, Kampala, T: 567708, F: 567649, E-mail: karihave@starcom.co.ug
- NARO (National Agricultural Research Organisation) and FOSRI (Food Science Research Institute), PO Box 7852, Kampala, F: 222657, Email: fosri@imul.com
- Nile Vocational Institute, PO Box 1829, Njeru, Jinja, T: 22389/22019
- PRESTO, PO Box 24204, Plot 21 Kawalya Kaggwa Close, Kololo, Kampala, T: 347481-3, F: 347635, E-mail: presto@imul.com
- PSF (Private Sector Foundation), 3 Kintu Rd. Kampala, T: 342163, F: 230956
- Redd Barna, 42 Bwala Hill, Masaka or 4105 Libuba Katwe, T: 21015, 268675
- Sasakawa Global 2000, Ruth Towers, PO BOX 6987, Kampala, T: 345497, F: 346087, E-mail: sguganda@starcom.co.ug
- SCF (Save the Children Fund), 5 Baskerville Ave, Kololo, Kampala, T 344796, 258815, 343486
- Small Enterprise Development Company 41 Oboja Rd, Jinja and 20 Kazooba Rd, Kabale, T: 21997
- SNV (Netherlands Development Organisation), PO Box 8339, 36 Luthusi Rise, Bugolobi, Kampala, T: 220584/2, 220780
- Ssemwanga Centre For Agriculture & Food, 47b Upper Kololo Terrace, Kampala, PO Box 40257, T: 346246/075 694612, F: 346246, E-mail: ssemwang@swiftuganda.com
- UMA (Uganda Manufacturers Association), PO Box 6966, Lugogo Showgrounds, Kampala, T: 220285/ 221034, F: 242455
- UIRI (Uganda Industrial Research Institute), Nakawa Industrial Estate, Plot M217 Jinja Rd, Kampala, PO Box 7103, T: 286245/077 406502, F: 285689,
- UNBS (Uganda National Bureau of Standards), PO Box 6329, Plot M217, Nakawa Industrial Area, Kampala, T: 222367/9, F: 286123, E-mail: unbs@starcom.co.ug
- USSIA (Uganda Small Scale Industries Association), PO Box 7725, Lugogo Showground, Kampala, T: 221785, F: 221038, E-mail: ussia@starcom.co.ug. Also PO Box 2344, Mbale or PO Box ?? Masaka
- VTI (Vocational Training Institute), PO Box 20121, Nakawa, Kampala, T: 20935/220028/236864

Engineering workshops

- Mr Kigongo-Kawesi, Tree Shade Technology Services, Bombo Road, Kampala, P O. Box 5833, T: 567698, F: 567698
- Mr Baljit Singh, JBT Engineering, Old Kampala, PO Box 11991, Kampala, T: 531339/077 488137
- Mr Bernard Bosso, Mechanical Engineering Department, Uganda Polytechnic Kyambogo, Kampala
- Mr Douglas Serroul, Adtranz, (Uganda Railways Mechanical Workshop), Nalukolongo, Masaka Rd, Kampala, T: 200580, F: 256047, E-mail: adtranz@infocom.co.ug
- Mr Fred Mukasa, Steelex, Bombo Road, PO Box 1765, Kampala, T: 567950

References and further reading

Root crop processing and products

- Drying Food for Profit, Axtell, A., 2002, IT Publishers, London. (ISBN 1 85339 520X)
- Food Dehydration, Brennan, J.g., 1994, Butterworth Heineman, Oxford. (ISBN 0 7506 1130 8)
- Food Processing Technology, Fellows, P.J., 2000, Woodhead Publishing, Cambridge, UK
- Improved post-harvest handling technologies for food crops in Uganda, Agona, A., *et al*, MAAIF and Sasakawa Global 2000, 1999.
- Integrated Food Science and Technology for the Tropics, 1985, Ihekoronye, A.I., and Ngoddy, P.O., Macmillan Press Ltd., London, UK.
- Jams, Pickles and Chutneys, Mabey, D.& R., 1985, Penguin Publications, Harmondsworth, UK.
- Opportunities in Food Processing, Fellows, P.J and Axtell, B.L.A., (eds), 2001, CTA, Wageningen, Netherlands,
- Practical Dehydration, Greensmith, M., 1998, Woodhead Publishing, Cambridge, UK. (ISBN 1 85573 394 3)
- Processing Tropical Crops, Asiedu, J.J., 1989, MacMillan Press Ltd, London, (ISBN 0-333-44857-X)
- Root crop processing, Adams, L. and Axtell, B.L., 1993, Food Cycle Technology Sourcebook: IT Publications, London, UK.
- Small Scale Food Processing: a guide to appropriate equipment, Fellows, P. and Hampton, A., 1992, IT Publications, 103-105 Southampton Row, London WC1B 4HH, UK (ISBN 1-85339-108-5)
- Solar Dryers - Their Role in Post-Harvest Processing, Brenndorfer, B., Kennedy, L., Oswin-Bateman, C.O., Trim, D.S., Mrema, G.C., and Wereko Brobby, C., 1987, Commonwealth Science Council, London, UK. ISBN 0 85092 282 8)
- Solar Drying: Practical Methods of Food Preservation, 1986, ILO, Geneva, Switzerland (ISBN 92 2 105357 1)
- Starting a Small Food Processing Enterprise, Fellows, P., Franco, E. and Rios, W., 1996, IT Publications, London, UK. (ISBN 1 85339 323 1).
- Traditional and Non-Traditional Foods, Ferrando,R., 1981, FAO Publications, Via delle Terme di Caracalla, Rome, Italy. (ISBN 92-5-100167-7)
- Traditional Food Technologies, Fellows, P., (Editor), 1997, IT Publications, London, UK.
- Tray Drying IT, Case Studies in the Dissemination of Tray Drying Technology, Axtell, B.L., and Bush, A., 1991, IT Publications, London, UK. (ISBN 1 85339 039 9).

Quality Assurance

- A practical approach to quality control, Caplen, R.H., 1982, Hutchinson Publishing Group, London, UK.
- Export Quality, World directory of Standardisation and Quality Assurance Related Institutions, Anon, 1992, ITC/UNCTAD/GATT, Geneva, Switzerland.
- Hazard Analysis Critical Control Point Evaluations, Bryan, F.I., 1992, WHO, Geneva, Switzerland.
- How to HACCP, an illustrated guide, Dillon, M and Griffith, C., 1999, MD Associates, 34a Hainton Avenue, Grimsby, UK.

Sanitation and Hygiene

- Affordable Water Supply and Sanitation, Pickford, J., Barker, P., Coad, A., Dijkstra, T., Elson, B., Ince, M., and Shaw, R (Editors), 1995, IT Publications, London, UK. (ISBN 1 85339 294 4).
- Codes of hygienic practice of the Codex Alimentarius Commission, Anon, Joint FAO/WHO Food Standards Programme, FAO Publications, Via delle Terme di Caracalla, 00100 Rome, Italy.:
- Disinfection of Rural and Small-Community Water Supplies, Anon, 1989, Water Research Centre, Medmenham, Bucks, UK.
- Making Safe Food (Book and Posters), Fellows, P., Hidellage, V., and Judge, E., 1995, CTA/IT Publications, London, UK.
- Safe Drinking Water, Howard, J., 1979, Oxfam Technical Guide, Oxfam, Oxford, UK.
- Safe Processing of Foods, Shapton, D.A. and Shapton, N.F., 1993, Butterworth-Heinemann, Oxford, UK.
- The Food Hygiene Handbook, Sprenger, R.A., 1996, Highfield Publications, Doncaster, DN5 7LY, UK (ISBN 1 871912 75X).

Packaging Materials and Labelling

- Appropriate Food Packaging, Fellows, P. and Axtell, B., 1993, IT Publications, London (ISBN 90 70857 28 6).
- Packaging, Obi-Boatang, P. and Axtell, B.L., 1995, Food Cycle Technology Sourcebook: IT Publications, London, UK.

Training

- Successful Approaches to Training in Food Processing, Battcock, M. Azam-Ali, S. Axtell B. and Fellows P.J., IT Publications, 136pp, 1998

Note: *FoodChain* is a publication concerned with small scale food processing that is free to subscribers in developing countries, published by Intermediate Technology Development Group, Boughton Hall, Boughton on Dunsmore, Rugby, CV23 9QZ, UK and has regular features on small scale root crop processing

Websites related to quality assurance, food safety, GHP, GMP and HACCP:

- Codex Alimentarius Commission, Official Standards, <http://www.codexalimentarius.net/search/search.do>
- European Union, the search page to find any EU Regulations (legislation in force), draft Regulations, dates of applicability, <http://europe.eu.int/eur-lex/en>
- European Union, Food Safety – From the Farm to the Fork – Site Map, http://europa.eu.int/comm/food/site_map_en.htm
- European Union, European Food Safety Authority, http://www.efsa.eu.int/index_en.html
- EU and UK Food Law, University of Reading, <http://www.foodlaw.rdg.ac.uk/index.htm>
- UK Food Standards Agency, <http://www.food.gov.uk>
- WHO Guidelines for Drinking Water Quality, http://www.wto.int/water_sanitation_health/dwq/guidelines/en

Annex B: Glossary and Acronyms

Acid preserves	foods such as jam that have a high acid content that inhibits spoilage.
Adulteration	deliberate contamination of foods with materials of low quality.
Brix	units of measurement of sugar concentration
Case hardening	rapid surface drying and hardening that prevents moisture leaving a food and results in inadequate drying and mould growth during storage
Chlorination	the addition of chlorine to water to destroy micro-organisms.
Contamination materials	materials that are accidentally included with a food (e.g. dirt, leaves, stalks etc.).
Critical control Points (CCP)	stages in a process where quality control can have a major effect on quality or safety.
Cross contamination food.	the transfer of soils or micro-organisms from raw food to processed
Enzymes	natural proteins in foods that can cause changes to colour, flavour or texture of the food.
Fill-weight	the amount of food placed into a container or package and written on the label (also net weight).
FIFO	First In – First Out inventory control system.
Humidity	the amount of water vapour in air.
Low-acid foods	foods that have little acid and therefore can contain food poisoning bacteria if poorly processed.
Micro-organisms	tiny forms of life, invisible until they are in large numbers, including moulds, bacteria and yeasts.
Minimum weight	all packages have a fill-weight equal to or greater than that shown on the label.
Net weight	the amount of food filled into a container.
Pectin	a natural gelling agent found in some fruits
pH	a scale used to express acidity or alkalinity, from 1 (strong acid) through 7 (neutral) to 14 (strong alkali).
Potable water	clean and wholesome water that will not cause illness.
Quality assurance	a management system which controls each stage of food production from raw material harvest to final consumption.
Refractometer	an instrument that measures the refractive index of a liquid, which is used to measure soluble solids in syrups or salt in brines.
Shelf life	the time that a processed food can be stored before changes in colour, flavour, texture or the number of micro-organisms make it unacceptable.
Sodium and metabisulphite	a chemical preservative that is effective against moulds and yeasts prevents browning of root crops

Acronyms

CCP	Critical Control Point
FIFO	First in - First out inventory system
GHP	Good Hygienic Practices
GMP	Good Manufacturing Practices
HACCP	Hazard Analysis Critical Control Point
ROPP	Roll on Pilfer Proof (caps for bottles)
TOTO	Twist on Twist off (lids for jars)
UHT	Ultra-High Temperature (sterilisation of foods)



UNITED NATIONS INDUSTRIAL DEVELOPMENT ORGANIZATION

Agri-Business Development Branch

Vienna International Centre, P.O. Box 300, 1400 Vienna, Austria

Telephone: (+43-1) 26026-3490

E-mail: agro-industries@unido.org, Internet: www.unido.org/agro