



TOGETHER
for a sustainable future

OCCASION

This publication has been made available to the public on the occasion of the 50th anniversary of the United Nations Industrial Development Organisation.



TOGETHER
for a sustainable future

DISCLAIMER

This document has been produced without formal United Nations editing. The designations employed and the presentation of the material in this document do not imply the expression of any opinion whatsoever on the part of the Secretariat of the United Nations Industrial Development Organization (UNIDO) concerning the legal status of any country, territory, city or area or of its authorities, or concerning the delimitation of its frontiers or boundaries, or its economic system or degree of development. Designations such as “developed”, “industrialized” and “developing” are intended for statistical convenience and do not necessarily express a judgment about the stage reached by a particular country or area in the development process. Mention of firm names or commercial products does not constitute an endorsement by UNIDO.

FAIR USE POLICY

Any part of this publication may be quoted and referenced for educational and research purposes without additional permission from UNIDO. However, those who make use of quoting and referencing this publication are requested to follow the Fair Use Policy of giving due credit to UNIDO.

CONTACT

Please contact publications@unido.org for further information concerning UNIDO publications.

For more information about UNIDO, please visit us at www.unido.org



The framework for sustainable leather manufacture

Jakov BULJAN, Ivan KRÁL'



UNITED NATIONS
INDUSTRIAL DEVELOPMENT ORGANIZATION



Copyright © 2015 by the United Nations Industrial Development Organization.

Materials in this paper may be freely quoted or reprinted, but acknowledgement is required, together with a copy of publication containing the quotation or reprint.

The designations employed, descriptions and classifications of countries, and the presentation of the material in this report do not imply the expression of any opinion whatsoever on the part of the Secretariat of the United Nations Industrial Development Organization (UNIDO) concerning the legal status of any country, territory, city or area or of its authorities, or concerning the delimitation of its frontiers or boundaries, or its economic system or degree of development. The views expressed in this paper do not necessarily reflect the views of the Secretariat of the UNIDO. The responsibility for opinions expressed rests solely with the authors, and publication does not constitute an endorsement by UNIDO. References to particular specialty chemicals or equipment do not represent any endorsement by UNIDO or preference over other similar products.

Although great care has been taken to maintain the accuracy of information herein, neither UNIDO nor its Member States assume any responsibility for consequences which may arise from the use of the material. Terms such as “developed”, “industrialized” and “developing” are intended for statistical convenience and do not necessarily express a judgment. Any indication of, or reference to, a country, institution or other legal entity does not constitute an endorsement. Information contained herein may be freely quoted or reprinted but acknowledgement is requested. This report has been produced without formal United Nations editing.

Acknowledgments:

The information and views as well as tables, drawings, photos, etc. in this paper are primarily intended to serve as background material for UNIDO workshops in developing countries; it is also hoped that they will be used for developing a practical eLearning programme on cleaner tanning technologies.

The data are drawn from the authors’ own experiences and several UNIDO papers, including in particular those dealing with desalting, hair-save liming, chrome management, benchmarking, OSH and effluent and treatment. Various data, information and views originating from IULTCS/IUE papers, EU BREF, C. Money, J.M. Salazar, M. Bosnić, M. Redwood, D. Tegtmeyer, T. Poncet, F. Schmel and other specialists and colleagues as well as from suppliers of specialty chemicals and equipment manufacturers are gratefully acknowledged. Special thanks to all individuals and companies who have responded to the UNIDO questionnaire.

The document reflects a work in progress. In view of great need and interest for balanced information on the issues mentioned, the study is posted as a “Working paper” in its unedited form and before final scrutiny and proofreading.

Table of Contents

PREFACE	1
1. INTRODUCTION	1
2. POLLUTION LOAD GENERATED BY CONVENTIONAL TECHNOLOGIES	1
2.1. General.....	15
2.2. Some pollutants of specific impact.....	18
3. TANNERY ENVIRONMENTAL MANAGEMENT SYSTEMS (EMS)	20
3.1. General.....	20
3.2. Building up your own EMS.....	22
3.3. Conclusion.....	30
4. WATER MANAGEMENT	31
4.1. Water saving strategies.....	32
4.2. Some practical examples of water saving measures.....	33
4.2.1. Washing.....	33
4.2.2. Low/short float techniques.....	34
4.2.3. Recycling and water reuse.....	34
4.2.4. Reduction of unnecessary material.....	35
4.2.5. Fleshing, vacuum dryers, finishing.....	35
4.3. Water consumption targets.....	35
4.4. Rainwater management.....	36
4.5. Banned substances in tannery effluents.....	37
5. RAW MATERIAL PRESERVATION, SALINITY	38
5.1. Traditional preservation methods.....	38
5.2. Alternative, more environmentally friendly preservation methods.....	40
5.2.1. Short-term preservation.....	40
5.2.2. Preservation with polyethylene glycol (PEG).....	42

6. BEAMHOUSE	4
7. SOAKING	4
7.1. Cleaner methods in soaking	48
7.1.1. Green fleshing.....	48
7.1.2. Salt removal.....	50
8. HAIR-SAVE UNHAIRING, LIMING	53
8.1. Liming with hair-burn unhairing	53
8.2. Hair-save unhairing	53
8.2.1. Painting.....	55
8.2.2. Hair-save lime-sulphide unhairing.....	56
8.2.3. Sirolime system (CSIRO, Australia)	57
8.2.4. Unhairing with organic sulphur compounds.....	57
8.2.5. Enzymatic unhairing	58
8.3. Hair separation and float recirculation equipment	58
8.4. Prevention of H₂S emissions from effluents	61
8.5. Oxidative unhairing	62
8.6. The scope for hair utilisation or disposal	62
8.7. Impact on pollution load	63
8.8. Summary on hair-save unhairing	64
9. DELIMING AND BATING	66
9.1. Fleshing	66
9.2. Splitting	66
9.3. Deliming	68
9.3.1. Polluting emissions	69
9.4. Cleaner technologies options	70
9.4.1. Replacing ammonium salts with weak organic acids.....	70
9.4.2. Deliming with carbon dioxide gas (CO ₂)	70
9.5. OSH at deliming	72
9.6. Bating	72
10. OPERATIONS IN THE TANYARD	74

10.1. General	74
10.2. The main features of the chrome tanning process	74
10.2.1. Pickling, tanning, basification	74
10.2.2. Recycling of pickle floats.....	76
10.2.3. Emissions	76
10.3. Better chrome tanning	79
10.3.1. Pickling.....	79
10.3.2. Tanning	79
10.4. Summary	89
10.5. Comparison of chrome balance:	91
10.6. Wet blue leather	92
11. PRETANNING AND WET-WHITE CONCEPT _____	9
12. OTHER TANNAGES _____	9
12.1. Mineral	98
12.2. Organic	98
12.2.1. Vegetable tanning.....	98
12.3. Chrome-free tanning – Tannages with syntans and other synthetic organic compounds	101
12.3.1. Environmental aspects	101
12.4. Oil tannage	102
13. WET FINISHING _____	103
13.1. Neutralisation	103
13.2. Retanning	104
13.3. Dyeing	105
13.4. Fatliquoring	107
13.5 Specific performance and related agents	108
13.6. Emissions	108
13.6.1. Emissions from retanning	109
13.6.2. Emissions from dyeing	110
13.7. Cleaner methods	111
13.7.1. Neutralisation	111
13.7.2. Optimised retanning	111
13.7.3. Optimised dyeing	112
13.7.4. Optimised fatliquoring.....	112

13.8. Dewatering, drying, conditioning, staking	113
14. FINISHING _____	118
14.1. General.....	118
14.1.1. Typical mechanical operations	118
14.1.2. Typical coating stages – layers.....	119
14.1.3. Coatings according to the character of grain.....	120
14.1.4. Coatings according to the type of the main finishing materials:	120
14.1.5. Binders	120
14.1.6. Colouring agents.....	121
14.1.7. Cross-linking agents.....	121
14.1.8. Lacquers and lacquers emulsions	121
14. 2. Pollution emissions and some mitigation measures	124
14.2.1. Airborne particulate matter	125
14.2.2. Solid waste and waste water	125
14.2.3. Organic solvents - Volatile organic compounds (VOC)	125
14.3. Pollution prevention and/or reducing measures	129
14.3.1. Improved coating techniques	130
14.3.2. High-volume low-pressure (HVLP) spray guns.....	130
14.3.3. Airless spray guns	131
14.3.4. Computer-aided spraying	131
14.3.5. Curtain coating	131
15. RESTRICTED SUBSTANCES _____	136
15.1. General.....	136
15.2. REACH	137
15.2.1. Restricted substances (Regulations, Annex XVII) of interest to tanners:	138
15.2.2. Substances of very high concern, SVHC (Regulations, Annex XIII)	138
15.2.3. SVHCs requiring special authorisation (Regulations, Annex XIV)	138
15.3. Practical considerations.....	139
15.3.1. Hexavalent chromium (chromium VI)	139
15.3.2. Formaldehyde.....	140
15.3.3. Azo-dyes	140
15.3.4. Nonylphenol and nonylphenol ethoxylates (NPE).....	140
15.3.5. Volatile organic carbon, VOC – organic solvents	140
15.3.6. Halogenated organic compounds present in various agents/auxiliaries.....	141
15.3.7. EDTA (ethylenediaminetetraacetate)	142
15.3.8. Pesticides	142
15.3.9. Biocides.....	143
15.3.10. Heavy metals	144
16. SOLID WASTE _____	145
16.1. Sources, quantities	145
16.2. Waste management	146

16.2.1. Prevention/mitigation	146
16.2.2. Utilisation and safe disposal	147
16.3. Conclusion	149
17. ENERGY CONSIDERATIONS IN LEATHER PROCESSING _____	151
17.1. General.....	151
17.2. Energy consumption.....	151
17.2.1. The share of energy consumption for the main components in a European tannery.....	151
17.2.2. The LWG Protocol	152
17.2.3. EU BREF 2013.....	152
17.2.4. Eco-design.....	152
17.2.5. Energy savings in leather manufacture, G. Sykes, World Leather	153
17.2.6. UNIDO paper.....	153
17.2.7. UNIDO paper/EU BREF 2003.....	154
17.2.8. Estimate of energy consumption for a virtual tannery of 10 t of w.s. hides/day (UNIDO)	154
17.3. Energy losses, costs	154
17.4. Use of non-traditional and/or renewable energy sources	155
17.4.1. Solar energy	155
17.4.2. Use of heat pumps.....	158
17.5. Optimisation of electric motors.....	160
17.6. Own generation of electric power (DG, photovoltaic)	160
17.7. Comparison of energy consumption for water heating and leather drying in a temperate versus a tropical zone	162
17.8. Energy and water and waste water	163
17.8.1. Treatment	163
17.8.2. Energy consumption related to waste water treatment	164
17.8.3. Comparison of energy consumption in (C)ETPs installed in temperate and tropical zones.....	165
17.8.4. Energy consumption for the aerobic biological treatment.....	166
17.11. A brief overview of the main energy savings measures	167
18. OCCUPATIONAL SAFETY AND HEALTH IN THE WORKPLACE (OSH) _____	169
18.1. Introduction	169
18.2. Basic principles of OSH management	169
18.3. Typical injuries and negative health impacts in tanneries and tannery effluent treatment plants.....	170
18.4. The main causes of safety risks and health hazards.....	170
18.5. Malodour	170
18.6. Hydrogen sulphide gas, H₂S	171

18.7. Bad odour problems related to effluent treatment plants.....	173
18.8. Particulate matter (dust)	174
18.9. Noise and vibration.....	174
18.10. Critical review of any new (cleaner) leather processing method.....	175
18.11. Material Safety Data Sheets, MSDS	175
18.12. Benchmarking in the area of occupational safety and health (OSH)	177
19. CARBON FOOTPRINT – LEATHER CYCLE ANALYSIS (LCA) _____	180
19.1. General.....	180
19.2. Glossary and basic concepts	181
19.2.1. Terms and Definitions (FROM ISO DIS 14067)	182
19.2.2. Environmental Footprint	183
19.3. Carbon footprint, Life Cycle Analysis (LCA) for leather.....	184
19.4. Overview of some contributors to CO₂ emissions in leather processing	186
19.4.1. CO ₂ emissions from raw material transport	186
19.4.2. Energy and CO ₂ emissions	186
19.4.3. Thermal energy.....	188
19.4.4. Waste Water Treatment.....	188
19.4.5. Product use and End of life (EoL).....	190
19.5. Case study, Bangladesh: Solar Water Heating System in a tannery.....	190
19.6. Analysis and recommendations (Brugnoli, UNIDO 2012)	190
19.7. Supplementary information from various sources.....	192
19.7.1. System expansions to handle co-products of renewable materials	192
19.7.2. BASF (China), September 2014	193
19.7.3. Eco-Design	193
19.7.4. BLC	194
19.7.5. UK, Environmental Reporting Guidelines	196
19.7.6. Footprint boundaries for Leather, D. Tegtmeier, IUR Commission, IULTCS	197
19.7.7. J. Knoedler, ITG, Germany	199
19.7.8. End of life (EoL), UNIDO 2014	201
19.8 Producer’s responsibility issues	201
20. EMERGING TECHNOLOGIES _____	20
21. CONCLUSION _____	20
REFERENCES _____	21

TABLES

Table 1. An example of mass balance in leather processing.....	17
Table 2. Estimated total pollution load from the global input of 10 million tons w.s.w./ year.....	17
Table 3. Typical pollution values in conventional tannery processes.....	31
Table 4. Water consumption in process stages (conventional processing).....	31
Table 5. BAT-associated consumption levels for water for the processing of bovine hides.....	35
Table 6. The theoretically lowest water consumption, stagewise.....	36
Table 7. Preservation by salting.....	40
Table 8. Short-term preservation.....	41
Table 9. The scope for reducing emissions from soaking.....	51
Table 10. Approximate sulphide dosing ranges.....	56
Table 11. The amount of hair in relation to hide/skin weight.....	62
Table 12. Pollution load: hair-save vs. hair pulping, decrease in %.....	63
Table 13. Overview of hair-save technologies.....	64
Table 14. Overview of ex-lime splitting.....	67
Table 15. Discharge of ammoniacal nitrogen during delimiting.....	69
Table 16. Emissions in waste water from delimiting and bating.....	71
Table 17. Overview of carbon dioxide, CO ₂ delimiting.....	71
Table 18. Overview of various delimiting systems, summary.....	72
Table 19. Overview of the main tanning systems.....	74
Table 20. The main controls of chrome tanning.....	76
Table 21. Chrome discharged in effluent from individual operations.....	78
Table 22. Overview of direct chrome recycling.....	84
Table 23. Influence of chrome recovery/reuse upon tanning/re-tanning efficiency.....	88
Table 24. Overview of chrome recycling by precipitation.....	88
Table 25. Advantages and limitations of high-exhaustion chrome tanning.....	90
Table 26. Advantages and limitations of chrome tanning with float recycling.....	90
Table 27. Advantages and limitations of chrome tanning with chrome recovery/reuse.....	90
Table 28. BAT-AELs for total chromium and sulphide emissions through indirect discharges of waste water from tanneries into urban waste water treatment plants.....	91
Table 29. Overview of pretanning – wet white concept.....	97
Table 30. Waste water volume and pollutant loadings per tonne of raw hide or skin from vegetable tanning including pickling, washing, and bleaching.....	100
Table 31. Emissions to waste water from conventional post tanning operations.....	109
Table 32. Sources of chromium discharges during wet finishing.....	109
Table 33. Energy consumption with various drying methods.....	117
Table 34. Solvents and diluents used in finishing (aqueous systems).....	122
Table 35. Solvents and diluents used in finishing (lacquers).....	122
Table 36. Finishing products – Approximate amounts required in grams/m ² of leather.....	124
Table 37. Solvent emission limits for leather coating.....	127
Table 38. Comparison of VOC emissions from different types of finishes.....	127
Table 39. BAT-associated solvent use levels and BAT-associated emission levels for VOC.....	128
Table 40. Comparison of conventional and HVLP spray guns.....	131
Table 41. Overview of leather coating methods.....	134
Table 42. An example of the amounts of solid waste, light European hides, shoe uppers.....	145
Table 43. Overview of re-use/recycling/recovery and/or.....	147
Table 44. The share of energy consumption for the main components in a European tannery.....	151
Table 45. Specific energy consumption associated with BAT.....	152
Table 46. Estimates of energy consumption in a French sheep tannery.....	153
Table 47. Estimates of the consumption of electric energy for various purposes in a French sheep tannery.....	153
Table 48. Typical effluent characteristics and treatment effects.....	163
Table 49. Some indicative effluent treatment plant parameters.....	164
Table 50. The main categories of air-transmitted hazardous or irritating substances.....	170

Table 51. Poisoning effects of hydrogen sulphide gas (H ₂ S).....	172
Table 52. The amount of CO ₂ (in grams) emitted per metric ton of freight & km of transportation	186
Table 53. Carbon dioxide emissions for energy from different sources	187
Table 54. Summary of Lifecycle of GHG emissions intensity for various	187
Table 55. The amount of CO ₂ emitted per GJ of energy for various fuels	188
Table 56. Estimated CO ₂ emissions from solid wastes in a well-managed solid waste disposal site	189
Table 57. Cleaner leather technologies at a glance	207

Figures

Figure 1. Correlation among key components of sustainable development	13
Figure 2. A simplified chart of the tanning industry	15
Figure 3. Sources and types of pollutants generated in leather processing	16
Figure 4. Comparison of the mean chloride loads.....	18
Figure 5. The PDCA cycle	20
Figure 6. Plastic sectors inside the drum, fixed with stainless steel screws	33
Figure 7. Installation of wooden sectors to improve drainage of floats.....	33
Figure 8. One of the three reservoirs of rainwater at Packer Leather, Narangba, Queensland, Australia	36
Figure 9. Brined and salted USA hides in Xuzhou Nanhai Leather Factory, China	39
Figure 10. Schematic representation of (a) dehydration process of hide matrix by PEG (b) rehydration process of PEG treated hide matrix	42
Figure 11. The sequence of typical operations in the beamhouse	44
Figure 12. The process sequence, input/output in the beamhouse.....	45
Figure 13. The share of the beamhouse in the total emissions, conventional process	46
Figure 14. The share of pollution load emanating from the beamhouse operations, conventional process	47
Figure 15. Operating principle of the fleshing machine	48
Figure 16. Green fleshing in Australia	49
Figure 17. Through feed fleshing machine	50
Figure 18. Drums for desalting of hides	50
Figure 19. Old wooden drum converted into a desalting drum	51
Figure 20. Brush type desalting machine	52
Figure 21. Dome type DODECA wooden frame for manual desalting.....	52
Figure 22. A schematic cross-section of bovine hide.....	54
Figure 23. A pile of painted sheep skins	55
Figure 24. Process diagram of hair-save liming with float recirculation.....	56
Figure 25. A battery of drums with semi-circular float collection gutters.....	59
Figure 26. Hair-save system with rotary drum filter and collecting pit.....	59
Figure 27. Hair-save set up, cross-section view.....	60
Figure 28. Screw type screen with compactor and container	60
Figure 29. Hydraulic heavy duty fleshing machine for calves, butt and cattle hides	66
Figure 30. Operating principle of splitting machine.....	66
Figure 31. A splitting machine for both ex-lime and wet blue splitting	67
Figure 32. Relationship between pH and release of H ₂ S gas.....	69
Figure 33. Flow chart of the main steps in the tanyard	75
Figure 34. The share of the tanning department in total emissions	77
Figure 35. Chrome balance in leather manufacturing	77
Figure 36. Share of Cr ₂ O ₃ discharged in effluent from individual operations under standard technological conditions in %	78
Figure 37. Shaving machine with cross-section schematic view	79
Figure 38. Effect of the final pH and temperature (°C) on tanning efficiency	81
Figure 39. Parameters to be optimised in the chrome tanning process.....	81
Figure 40. Comparison of chrome distribution.....	83
Figure 41. A practical example of direct chrome recycling system	85
Figure 42. Chrome recovery by precipitation with sodium hydroxide/carbonate.....	86

Figure 43. Chrome recovery by precipitation with MgO	87
Figure 44. Wet blue sammying machine, seven cylinders, six sammying points	92
Figure 45. Flow chart of pretanning and wet white tanning.....	94
Figure 46. Schematic view of the PCMS bonding mechanism.....	95
Figure 47. The suggested tanning mechanism of the EasyWhite Tan method	96
Figure 48. Vegetable tanning agents.....	99
Figure 49. One of many variations of operations in preparation of wet blue for dry finishing.....	103
Figure 50. Structures of aromatic and aliphatic retanning agents	105
Figure 51. The share of post-tanning in total emissions	110
Figure 52. Double felts combined sammying and setting out machine	114
Figure 53. Schematic cross-section view of jaw- and vibro- staking machines.....	114
Figure 54. Vacuum dryer.....	115
Figure 55. Vibro-staking machine	115
Figure 56. A traditional toggle dryer.....	116
Figure 57. Toggle dryer, of the Cell Rotaring Conditioning (CRC) System, inside view.....	116
Figure 58. Milling drum.....	117
Figure 59. Vibro-staking machine	118
Figure 60. Schematic cross-section view of the buffing and dedusting machine.....	119
Figure 61. Buffing and dedusting machine	119
Figure 62. Operating principle of compressed air spraying machine and spraygun	123
Figure 63. A head of the rotary spraying machine	123
Figure 64. The share of finishing in total emissions	124
Figure 65. Hydraulic plating and embossing press.....	129
Figure 66. Operating principle of the curtain coater.....	132
Figure 67. Operating principle of the roller coater.....	132
Figure 68. Reverse and forward roller coaters: schematic view.....	133
Figure 69. Roller coater.....	133
Figure 70. Ironing machine, adjustable pressure	134
Figure 71. Low cost drying in a developing country.....	135
Figure 72. Typical solid waste ranges according to EU BREF 2013	146
Figure 73. Overview of the tanning operations and linkages.....	150
Figure 74. The world insolation map.....	155
Figure 75. A simplified scheme of solar supported water heating with storage.....	156
Figure 76. Solar collector efficiency curve.....	156
Figure 77. Solar collectors installed in a tannery under UNIDO project in Bangladesh	157
Figure 78. A simplified scheme of the heat pump	158
Figure 79. World climate zones – mean temperatures	162
Figure 80. (C)ETP energy consumption vs. capacity.....	165
Figure 81. Basic principles of OSH management.....	169
Figure 82. The main tannery streams, segregation	171
Figure 83. Cover page of UNIDO H ₂ S manual.....	172
Figure 84. Evolution of global population (red) and global carbon dioxide emissions (blue) since 1900.....	180
Figure 85. Cattle stock population	180
Figure 86. Overview leather processing – UNIDO/LCA Brugnoli	185
Figure 87. Model for describing system expansion and delimitation in relation to co-production.....	192
Figure 88. Baseline results for each tanning technology, general LCA impacts	195
Figure 89. Process chain of leather manufacturing.....	197
Figure 90. Examples for Water- and Carbon footprint splits based on traditional product category rules (PCR).....	198
Figure 91. Carbon dioxide, CO _{2e} /m ² of leather	200
Figure 92. A tannery or a pharmaceutical plant?	206
Figure 93. Decrease of pollution loads in waste water after introducing advanced technologies, %.....	209

PREFACE

If all the forests will disappear, man will be left with only his family tree to weep on.

Albert Einstein

There is no shortage of papers dealing with some specific aspects of pollution control, including cleaner technologies in leather manufacturing such as operations in the beamhouse, (chrome) tanning or finishing. On the other hand, there is much less widely accessible information providing a comprehensive overview about the scope of preventing and/or reducing the polluting emissions along the entire leather-making process.

Documents prepared by the Environmental Commission (IUE) of the International Union of Leather Chemists and Technologists Associations (IULTCS) and the Best Available Techniques Reference Document (BREF) prepared in the European Union (both updated from time to time) are globally referred to for guidance on what can be considered a cleaner technology method.

However, while being very useful, they do not quite coincide with the profiles and needs of a large segment of tanners, especially in developing countries. BREF is written in a specific format for conditions prevailing in the EU whereas the IUE set of documents might not be detailed enough for practical purposes.

In the last few decades, under various projects of technical assistance and under the auspices of its well-established Leather and Leather Products Industry Panel, UNIDO has prepared a number of studies dealing with various cleaner tanning methods such as mass balance, desalting of raw hides/skins, hair-save unhairing, chrome balance/chrome management, hair-save liming, detection and avoidance of hexavalent chromium, etc. Now it is believed to be the time to prepare a single, comprehensive study on cleaner leather technologies, round up and update earlier papers, and supplement the IUE and BREF documents.

In this paper an attempt has been made not only to revisit the traditional “standing” issues (water saving, deliming, chrome management, etc.) but also to present a fresh, neutral assessment of some cleaner methods based on years of experience.

In conformity with new trends (and environmental/legislative pressures!) both wet and dry finishings are discussed in more detail than used to be the case.

Energy consumption, traditionally on a sidetrack (if not totally ignored), is also now looked at more closely.

Serious scientific papers and media headlines about greenhouse effects/global warming and the anticipated public pressures on the leather industry, including current discussions in

various leather fora possibly triggered by the UNIDO Leather Panel meeting in September 2012 in Shanghai resulted in a mosaic of information and views under the Life Cycle Analysis (LCA) – Carbon Footprint (CF) chapter.

Indeed, throughout the paper the approach is to present information about experiences gathered and options available to date and to point out their advantages and disadvantages without strong preference, certainly not “imposing” a particular method. After all, there is no general consensus, for example, even about the right terminology as many people think that there is no such thing like *the best available technology* because “...a particular technology may be best for one situation but not for another...” and instead “... appropriate technology should be adopted”¹.

In this context, it is useful to remember that there is no unified approach on what is to be classified as a hazardous substance. Possibly (over)simplifying the matter, it could be said that the EU approach is that strong suspicion about potential harmful effect(s) suffices whereas in the USA the negative impact has to be proven.

Finally, it cannot be overemphasised that a significant decrease of polluting loads can be achieved by strict process monitoring and control and/or minor modifications of the existing technologies, i.e. without high investments and use of expensive proprietary specialty chemicals.

Some repetitions in the paper are because it is expected that ultimately the paper will be a part of the UNIDO eLearning system where for practical reasons it is useful to have some chapters as nearly independent, stand-alone documents.

¹ C. Money

1. INTRODUCTION

Restoring and maintaining the balance between natural resources and consumption and population growth is one of the key elements for the future of humanity. Generally, it is taken for granted that human impact is (easily) measurable.

In reality, there is no universally accepted measuring system and/or unit. Among those proposed are the Sustainability Development Indicator (SDI), the Human Development Index (HDI), the Environmental Sustainability Index (ESI) and the Environmental Performance Index (EPI). Very interesting is also the IPAT equation:

Human Impact (I) = Population (P) x Affluence (A) x Technology (T) where
A = consumption per capita and T = environmental impact per unit of consumption.

Possibly the best is the sustainability approach proposed in the UN Brundtland Commission Report (1987) stating: *Sustainable development is development that meets the needs of the present without compromising the ability of future generations to meet their own needs.*

The Daly Rules approach (possibly founded on ecological/thermodynamic principles) suggests the following criteria of sustainability:

- Renewable resources (e.g. fish, soil, groundwater) must be used no faster than the rate at which they regenerate.
- Non-renewable resources (e.g. minerals, fossil fuels) must be used no faster than renewable substitutes for them can be put into place.
- Pollution and wastes must be emitted no faster than natural systems can absorb them, recycle them, or render them harmless.

Some other authors² suggest that sustainability indicators should be holistic in nature, measuring sufficiency of well-being for all, sustainability of natural resources and efficiency of converting resources to universal well-being; they believe that complex systems require multiple viewpoints to adequately express the needs of all in the system. In that context sustainability (like in nature) also implies maintaining adaptive capability, development means maintaining opportunity so that sustainable development corresponds to fostering adaptive capabilities and creating opportunities.

In essence, sustainability calls for renewable raw materials, recycling and waste reduction. The tanning sector must adhere to these principles at every stage especially since from time immemorial its perception was quite bad, its status in virtually all cultures around the world

² See: <https://www.youtube.com/watch?v=RCN6it0LZvY>
<https://www.youtube.com/watch?v=-jnH9o8Ajd0>
<https://www.youtube.com/watch?v=Q3tJL4JRgnA>

among the lowest. Even nowadays, the malodours from poorly run tanneries overshadow the fact that, for example, production of one square metre of blue jeans requires about ten times more water than of one square metre of leather.

Figure 1. Correlation among key components of sustainable development



Source: F. Schmel, UNIDO, Sustainable Development Goals, SDG

According to a comprehensive computation of mass balance and efficiency of leather manufacturing in a conventional process only about 50% of corium collagen and less than 20% of the chemicals used are actually retained in the finished leather.

The primary tasks of all cleaner technologies are to reduce the amount, possibly change the nature of pollution emissions, and thus reduce the pressure and costs of end-of-pipe treatment.

Generally, absorption of new technologies in the leather sector is traditionally slow; established methods last for a long time. The main reason is that despite considerable progress made during the last few decades, leather manufacturing is a mixture of science, technology and craft, the nature of some processes still not fully understood. Keen to preserve the most important aspect, the quality of leather produced, tanners are quite reluctant to modify the existing process and possibly negatively influence the quality. Also, owing to inherent characteristics of the raw material and desired properties of the finished leather, cleaner tanning methods have their limitations; ultimately, a substantial percentage of all raw material and chemicals input ends as waste.

There is no doubt that from the holistic, macro- and long-term perspective, environment-friendly tanning methods are more favourable and cheaper. However, for the individual

tanner, cleaner technology methods are usually more costly due to the cost of more sophisticated equipment and specialty chemicals. The main benefits are better conditions in the plant and a better image with international buyers.

From time to time, most frequently in Europe and mainly among non-specialists, debates surface about comparative environmental advantages of chrome-free synthetic agents and vegetable versus chrome tannage as the prevailing basic tanning method.

The pressure to adopt cleaner technologies normally emanates from environmental imperatives such as the need to meet specific discharge norms, reduce treatment costs or comply with occupational safety and health (OSH) standards. The typical primary targets are:

- Lower water consumption
- Improved uptake of chemicals
- Avoidance of hazardous and/or banned substances (Substances of Very High Concern, SVHC)
- Better quality/re-usability of solid waste and reduced content of specific pollutants such as heavy metals³ and electrolytes contained therein

The spread of cleaner technologies and processes is neither spontaneous nor extensive. For all the claims about favourable cost-benefit ratios and/or environmental benefits to be derived from many of these technologies, tanners are not quick in adopting them, be it due to inertia, often higher costs or limitations mentioned earlier.

Contrary to some misperceptions extensive investigations have shown that chrome tanning remains the most environmentally efficient tanning method whereas vegetable and synthetic tanning agents are preferred when specific leather properties are required like in the case of sole and saddlery leathers (vegetable) and automotive leathers which need dimensional stability (synthetic tannage).

In view of ever increasing legal, local and global social pressures⁴, no tanner can afford the luxury of not being familiar with the main issues and principles of environmental protection pertaining to tannery operations. Pollution prevention, persistent promotion of cleaner leather processing, ultimately leading to lower treatment costs, obviously remains of paramount importance.

³ *Although widely used there is no clear technical definition of what it covers.*

⁴ *In this context refer to the [UN Millennium Development Goals \(MDG\)](#), from Rio Conference in 2000 given a fresh impetus by [Post-2015 UN Development Agenda and the Sustainable Development Goals \(SDG\) plan](#).*

2. POLLUTION LOAD GENERATED BY CONVENTIONAL TECHNOLOGIES

2.1. General

Leather manufacture is a series of operations from preservation to finishing with the aim of converting quickly degradable, highly putrescible raw hides and skins into leather, a stable initial material suitable for use in production of a very wide range of articles: footwear, apparel, dress and protective gloves, in furniture and the automotive industry, saddlery, etc.

To achieve this aim, it is necessary to apply rather complex mechanical and physical-chemical processes, the tanning step being decisive for giving the stability and character.

While there are already certain synthetic materials which can match or even outperform in some specific areas/purposes (e.g. ski boots), leather characteristics such as feel, elasticity, permeability for air and perspiration, temperature and water resistance, stability, durability, and attractive appearance make it a highly desirable material with a touch of class and luxury.

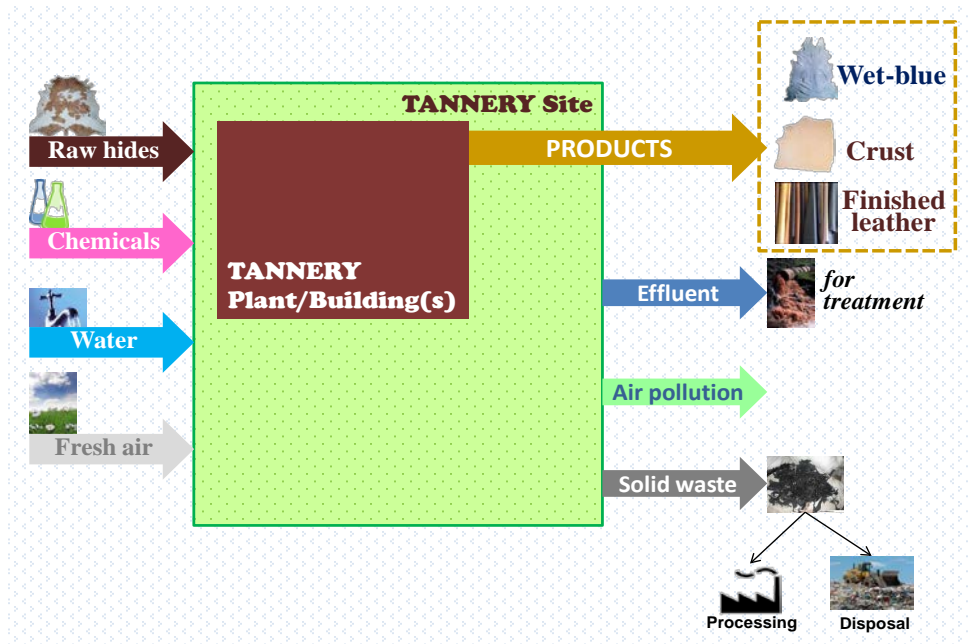

Chart by F. Schmel, UNIDO

Figure 2. A simplified chart of the tanning industry

Due to varieties in raw materials, processing, chemicals and water consumption, it is a small wonder that in literature the figures about pollution load generated in the course of leather production vary a lot and should be interpreted very cautiously. The chart and tables below may give the general idea, the reference being a tonne of wet salted hides.

For the same reason it is practical to indicate the amount of pollutants generated per tonne of raw hide input. While generally lower water consumption is very desirable (nowadays in well-managed tanneries below 30 m³/tonne), it obviously results in a considerably higher concentration of pollutants.

Figure 3. Sources and types of pollutants generated in leather processing

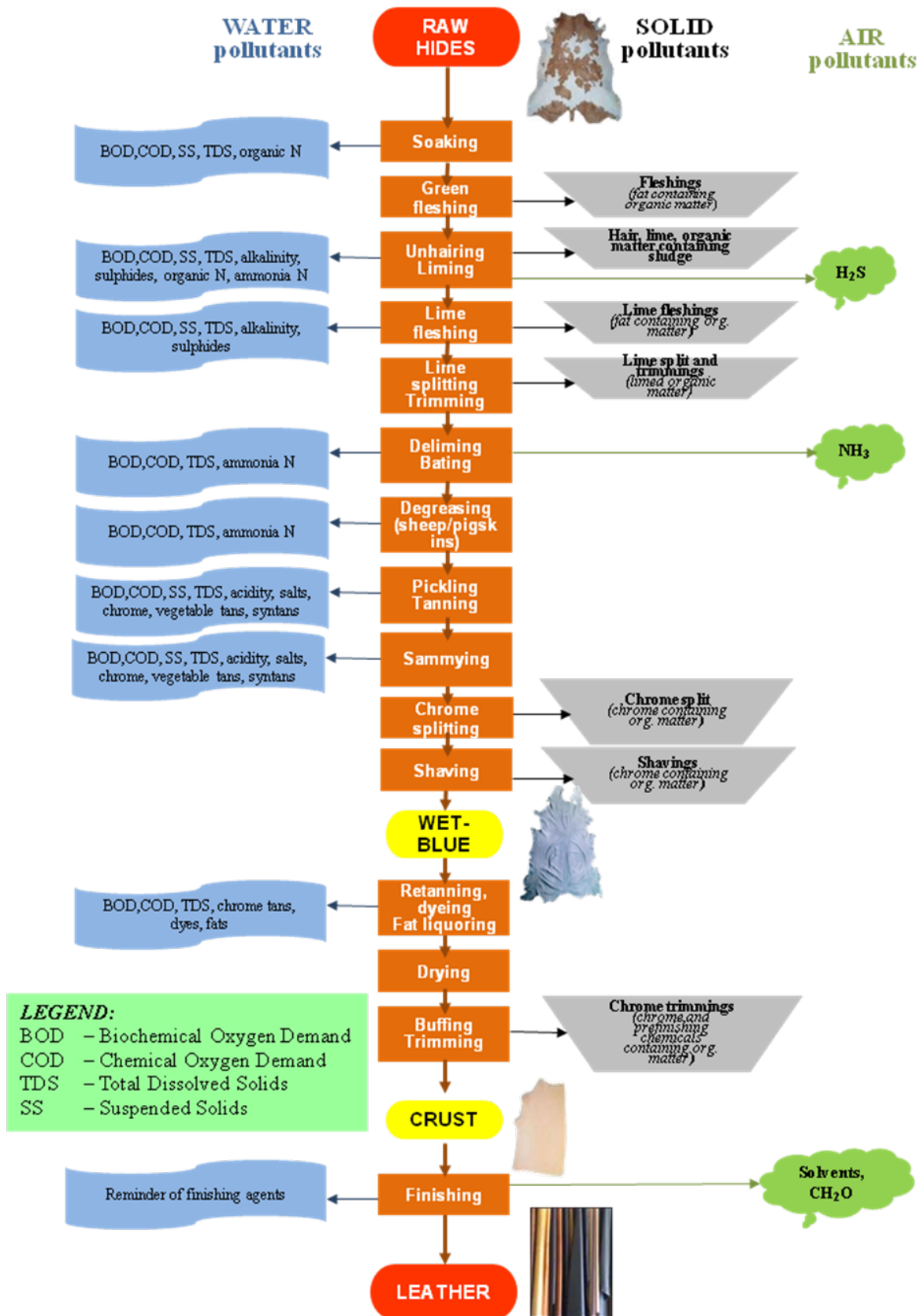

Table 1. An example of mass balance in leather processing

Example of mass balance of chemicals in leather processing			
Kg/ ton of wet salted hide			
Chemicals	Added in process	in/on leather & splits	Wasted
Chrome oxide, Cr ₂ O ₃	25	12	13
Organic tannins	25	20	5
Fatliquors	22	17	5
Dyestuffs	5	4	1
Acids, bases, salts	191	-	191
Tensides	3	-	3
Enzymes	5	-	5
Finishing products	100	12	88
Total	452	72	380

Note: EU (BREF 2013) figures about chemicals added are even higher whereas one supplier (BASF) suggests a very wide range of 168 – 493 kg/t of w.s.w.

Approximate full chemical mass balance from preservation to finishing

Salting (cca 40% of the hide fresh weight) + resalting (during longer storage up to 10%) plus chemicals in leather processing, including reprocessing (cca 45% on w.s. weight), total approximately 90% of fresh hide weight. It means that the ratio of **chemicals used vs. fresh hide/skin weight is $\approx 0.9:1.0$**

After adding the amount of chemicals typically used for purification of tannery effluents (coagulation, flocculation, sludge conditioning), it can be safely said that the actual ratio of **chemicals used to fresh hide weight is $\approx 1 : 1$** .

Table 2. Estimated total pollution load from the global input of 10 million tons w.s.w./ year

Parameter	Typical pollution load, conventional process kg/tonne of w.s. hide	Approximate global discharge Thousands of tonnes/year
Biochemical oxygen demand, BOD ₅	90	900
Chemical oxygen demand, COD	180	1800
Suspended solids, SS	90	900
Chromium, Cr ³⁺	7	*56
Sulphides, S ²⁻	7.5	75
Total Kjeldahl Nitrogen (TKN)	12.5	125
Chlorides, Cl ⁻	225	2250
Sulphates, SO ₄ ²⁻	63	630
Oil and grease	6	60
**TDS	450	4500

*After allowing 20% for chrome-free tannages **Mainly chlorides and sulphates

Somewhat paradoxically, the obvious is often overlooked: the same amount of pollutants at lower water consumption means lower hydraulic load (volume) but higher concentration which is not always easy to treat.

With the view of keeping it short and concise, there are many simplifications and omissions of details; thus, for an in-depth understanding of the complexities of specific processes it is recommended to consult extensive literature on this subject.

Finally, although contrary to widespread misperception that vegetable tanning is environmentally harmless (in reality its effluent has a very high and difficult to treat COD), here it is mainly dealt with combined chrome tanning only because it is by far the most prevailing leather tanning method.

2.2. Some pollutants of specific impact

Salt/chlorides

It mainly emanates from the soaking and tanning stages of salted or brine-cured hides and from pickling; highly soluble and stable, unaffected by waste water treatment thus making the final, treated effluent unfit for irrigation or livestock watering. At present possibly the hardest challenge of leather the industry is in arid regions.

Figure 4. Comparison of the mean chloride loads

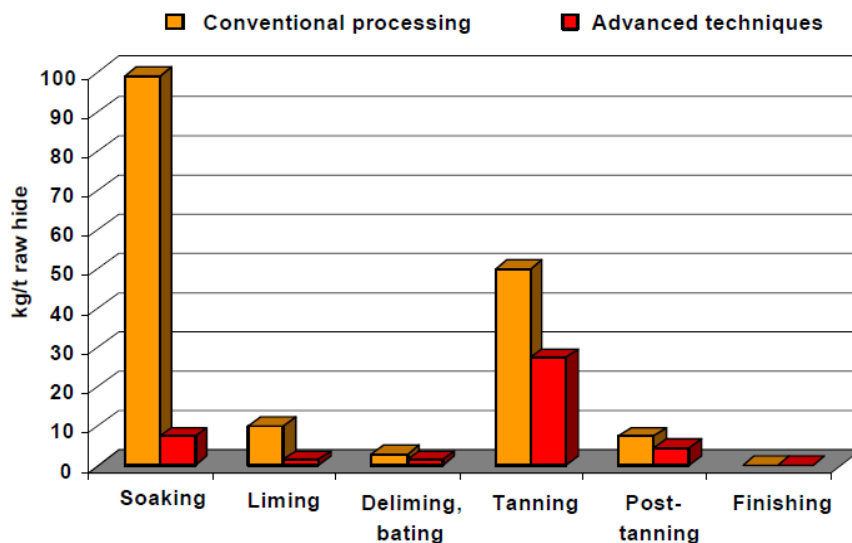

Sulphates

The main source is the delimiting process (ammonium sulphate), followed by the tanning (chrome powder) and post-tanning stages as well as catalytic oxidation of sulphides in the beamhouse effluents.

Many process chemicals contain “hidden” sodium sulphate (e.g. retanning agents).

Sulphide

The residual sulphide in effluents is easily oxidized into sulphate. The real issue is the risk of the formation of highly toxic hydrogen sulphide

- i) due to poor segregation of streams and mixing with acidic spent floats as the pH of the effluent drops below 9.5
- ii) due to anaerobic conditions and reverse reaction (action of sulphur-reducing bacteria, long waste water pipe work/collection network).

Substances with specific water-polluting potential

Substances with specific water-polluting potential due to:

- acute toxicity on mammals
- aquatic toxicity on fishes, dolphins, algae and bacteria
- biological degradability (hydrolysis, photolysis, oxidation, etc.)
- soil mobility
- ability to accumulate biologically
- carcinogenic effect
- mutagenic effect
- teratogenic effect (i.e. causing malformations or functional damage to an embryo or a foetus).

Most of such substances are on the Restricted Substances Lists (RSL) and/or Substances of Very High Concern List (SVHC); see chapter 15.

3. TANNERY ENVIRONMENTAL MANAGEMENT SYSTEMS (EMS)

3.1. General

The International Organization for Standardization (ISO) in its ISO 14001:2004 defines the Environmental Management System (EMS) as part of an organization's management system used to develop and implement its environmental policy and manage its environmental aspects. It emphasises that the overall aim of this Standard is to support environmental protection and prevention of pollution in balance with socio-economic needs and stresses the importance of an effective EMS being well integrated into the organization's management system.

Environmental labelling and life-cycle assessment belong to the same ISO 14000 family of voluntary standards.

The motivation for the establishment and implementation of an EMS (certified or non-certified) is normally based on a combination of the following elements:

- Better overall environmental performance, avoidance of non-compliance costs
- Better insight into environmental aspects of the tanning operations, pollution and wastes generated which are, in different form and levels, of interest to the environmental protection bodies, NGOs, inhabitants of the adjacent residential areas, etc.
- Improved basis for decision-making
- Pressure, direct or indirect by the buyers concerned about their own public perception
- Drastic reduction of frequency of injuries at work; serious injuries do not happen at all.
- Due to better working conditions, reduction and/or elimination of harmful or irritating substances in the long run there are less chronic illnesses and absences from work.
- Improved company image
- Closer involvement and eventually better motivation of all personnel, a feeling of shared responsibility for pollution prevention and safety at work
- Lower volume and lower costs of disposal of non-utilizable wastes; sometimes there can be a reduction of operational costs.

ISO 14001:2004 is based on the methodology Plan-Do-Check-Act, in short PDCA which could be represented by the following diagram:

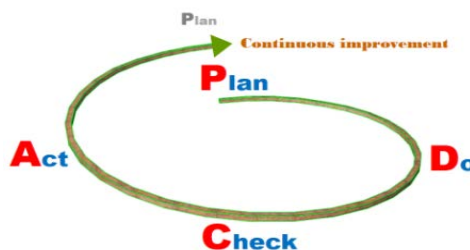

Figure 5. The PDCA cycle

Chart by F. Schmel, UNIDO

Since the process is continuously revisited and reviewed, every EMS is a process of continual improvement.

It is quite interesting that ISO 14001 does not include Occupational Safety and Health (OSH) at the work place aspect although in practice, at the shop-floor level, environmental protection and pollution prevention are so intertwined with OSH that they simply cannot be viewed apart. In the ISO system OSH is addressed under ISO 18000.

EMS in a tannery implies irreversible departure from the practice of addressing the environmental issues in a reactive and *ad hoc* manner, which often delegates them to a junior level manager to handle them as a temporary nuisance. EMS calls for a coherent, systematic, thoroughly designed, documented and planned approach with clearly defined strategic goals as well as specific medium- and short-term targets and explicit distribution of implementation responsibilities, regular reviews, verifications, improvements, etc. including dissemination of information and extensive training activities at all levels.

It is essential that wherever applicable environmental protection targets and performances are defined and set in measurable terms.

The main components of a tannery EMS

- Commitment of management, including senior management;
- Definition of an environmental policy that includes the continuous improvement of tannery operations;
- Planning and establishing the procedures, objectives and targets, in conjunction with financial planning and investment;
- Implementation and operation of procedures paying particular attention to:
 - ✓ structure and responsibility
 - ✓ training, awareness and competence
 - ✓ communication
 - ✓ employee involvement
 - ✓ documentation
 - ✓ efficient process control
 - ✓ maintenance programmes
 - ✓ emergency preparedness and response
 - ✓ safeguarding compliance with environmental legislation;
- Checking performance and taking corrective action paying particular attention to:
 - ✓ monitoring and measurement
 - ✓ corrective and preventive action
 - ✓ maintenance of records
 - ✓ independent (where practicable) internal and external auditing in order to determine whether or not the EMS conforms to planned arrangements and has been properly implemented and maintained.
- Review of the EMS and its continuing suitability, adequacy and effectiveness by senior management;
- Preparation of a regular environmental statement;
- Non-mandatory validation by certification body or external EMS verifier;
- Development of cleaner technologies;
- Consideration for the environmental impacts from the eventual tannery decommissioning at the stage of designing a new plant, and throughout its operating life;
- Application of a full scale benchmarking

Derived from BREF 2013

While large tanneries might turn to external inputs and standardized procedures for setting up or upgrading the existing EMS, medium and smaller units can opt for developing their own EMS tailored to their specific needs. Properly designed and implemented, they can produce satisfactory results that can be easily verified and ultimately accepted by external auditors (giving higher credibility) and/or representatives of environmental enforcement authorities and the NGO. It is hoped that this paper will be of use for such purposes.

3.2. Building up your own EMS

A good starting point for building your own EMS can be the elements of benchmarking related to environmental and occupational safety and health at work (OSH) contained UNIDO paper *Benchmarking in the Tanning Industry (2011)* reproduced here for your convenience. For better understanding, parts of some other chapters of interest are also given.

The outline of ten “cock-pit check lists”:

Check list No.	Area – Component
1	Tannery location, infrastructure
2	Production parameters
3	Cleaner technologies
4	Energy management and consumption
5	Quality assurance, reprocessing, delivery time, failures
6	Product development, strategies
7	Occupational safety and health at work, maintenance
8	Effluent treatment, solid waste, air emissions
9	Financial indicators
10	Human resources and staff welfare, Corporate Social Responsibility, CSR

CLEANER TANNING TECHNOLOGIES

A comprehensive computation of mass balance and the efficiency of leather manufacturing indicates that, for a number of reasons, in a conventional process only about 50% of corium collagen and less than 20% of the chemicals used are actually retained in the finished leather. The primary task of all cleaner technologies is to reduce the amount and possibly change the nature of pollution emissions and thereby reduce the pressure and the cost of end-of-pipe treatment.

Check list 3: Cleaner technologies

3.	<i>Production stage – method – process</i>	Yes	No
	Raw material		
3.1	Green fleshed, preferably in the abattoir		
3.2	Short-term preserved by appropriate chilling, i.e. green – salt-free		
3.3	If applied, then only environmentally acceptable biocides used		
3.4	Dried (primarily skins) under well controlled conditions		

3.	<i>Production stage – method – process</i>	Yes	No
	General		
3.6	Strict water management system (including batch rinsing instead of by continuous flow)		
3.7	Float recycling both to reduce water consumption and/or improve the uptake of chemicals		
3.8	Segregation of all chrome-bearing streams		
3.9	Avoidance and monitoring of banned and/or potentially harmful substances such as pentachlorophenol (PCP), hexavalent chromium (Cr ⁶⁺), free formaldehyde and forbidden aromatic amines		
3.10	Substitution of all chemicals with strong negative environmental impact, including low biodegradability (e.g. some complexing agents, halogenated organic compounds, organic solvents, etc.) with friendlier alternatives		
3.11	Use of least potentially environmentally harmful biocides at all stages (curing, soaking, pickling, tanning, post-tanning)		
3.12	Avoidance of potentially environmentally harmful surfactants such as nonylphenol ethoxylates, NPE ⁵ , at all stages (soaking, liming, tanning, post-tanning)		
3.13	Preference for chemicals with low neutral salts content		
3.14	Highest possible exhaustion level of chemicals used		
3.15	Monitoring and control of “hidden” presence and/or emissions such as organic solvents contained in finishing chemicals, volatile organic compound (VOC) releases from leather during storage		
3.16	Specific targets – ceilings set for pollution loads (biological oxygen demand – BOD, chemical oxygen demand – COD, suspended solids – SS, total Kjeldahl nitrogen – TKN, TDS, etc.) discharged from the main processing steps (liming, deliming, tanning, retanning, etc.) ⁶		
3.17	Specific targets – ceilings set for the pollution load (BOD, COD, SS, TKN, TDS etc.) contained in the combined effluent		
3.18	Specific targets – ceilings set for all hazardous and/or unpleasant air emissions (VOCs)		
	Specific processing stages		
3.19	Desalting of wet salted hides and skins		
3.20	Hair-save unhairing with hair separation and, ultimately, utilization		
3.21	Splitting of limed pelts (ex-lime splitting)		
3.22	Highest technically possible accuracy of splitting whether in lime or after (pre)tanning		
3.33	Low- or ammonium salt-free (carbon dioxide) deliming		
3.34	Short pickling floats preferably with recycling		
3.35	Full scale chrome management of chrome emanating from the main tannage (high chrome exhaustion, direct recycling of tanning floats, chrome recovery/reuse after precipitation) but also from all other chrome emissions (retanning, sammying, any “bleeding”)		
3.36	Vegetable tanning exhaustion rate not less than 95% (counter-current pit and drum tanning with recycling)		

⁵ *Endocrine glands disrupter*

⁶ *Due to the lower water consumption – higher pollution load concentration effect, it is important to monitor not only the concentration (mg/l COD) but also the pollution load (kg of COD).*

3.	<i>Production stage – method – process</i>	Yes	No
3.37	Use of syntans and resins with low-phenol, -formaldehyde and low acrylic acid monomer content		
3.38	Optimized mechanical dewatering and forced drying		
3.39	Environmentally friendly finishing: predominantly water based; avoidance of isocyanates and aziridines; preference for roller/curtain coating; in case of spraying use of high volume, low pressure (HVLP) and airless methods		
3.40	Strict use of abatement techniques (wet scrubbing, absorption, bio-filters) to reduce VOC content in as well as malodour of air emissions.		
Recommendations:			

The main expected favorable impacts of cleaner technologies are lower overall pollution and hydraulic load with correspondingly lower effluent treatment investment and operating costs. More specifically cleaner technologies result in:

- Lower water consumption – better preservation of rapidly diminishing water resources
- Lower TDS content/salinity – lower risk of affecting the usability of the receiving river water for irrigation and livestock watering
- Proportionally higher volume of solid wastes suitable for processing into saleable by-products
- Lower BOD, COD and Nitrogen content within acceptable range – protection of aquatic life, avoidance of eutrophication
- Low level of chromium in CETP sludge – makes possible land application and/or composting
- Lower hazardous and/or unpleasant air emissions

Unfortunately, little is known about the long-term environmental impact of some chemicals such as biocides and surfactants, their possible chronic toxicity or their role as endocrine disruptors. Typical toxicity tests observe acute toxicity only and are limited to a few species.

In general, it can be said that the currently available cleaner tanning technology methods can drastically reduce the pollution load, but the need for end-of-pipe treatment remains.

ENERGY

Despite its relatively low share in the total production cost (typically up to 5%), considerable energy savings can be made by careful selection of methods and equipment as well as close control of thermal efficiency. Wherever possible, the principle “no production, no consumption” should be strictly followed.

Check list 4.1: Energy management

4.1	Description	Yes	No
	Energy management		
4.1.1	All warm water and steam pipes well insulated, no leakages		
4.1.2	Hot-cold water mixing system well calibrated, short adjustment cycles		
4.1.3	Optimised mechanical dewatering (sammying)		

4.1	Description	Yes	No
4.1.4	If viable, natural drying used (especially for high quality soft leather skins)		
4.1.5	Optimal drying regime in drying chambers and tunnels (e.g. higher air velocity, lower temperature)		
4.1.6	Infrared heating used for drying in finishing		
4.1.7	Solar energy supported drying		
4.1.8	Use of heat pumps		
4.1.9	Electromotors' capacity optimized (usually 75% of maximum performance)		
4.1.10	Hot water/steam boiler and auxiliary components design and performance allows only lowest technically possible losses		
4.1.11	Wherever viable, waste heat (e.g. from vacuum driers, compressors) recovered		
4.1.12	Steam condensate recovered		
4.1.13	The scale of operations permitting, part of energy needs obtained from anaerobic digestion of fleshings and sludge		
4.1.14	The scale of operations permitting, part of energy needs obtained from incineration from chrome-free solid wastes (fleshings, fat)		
4.1.15	Automatic and/or manual controls of heating/cooling/ventilation/lighting systems in place		
Recommendations:			

Check list 4.2: Energy consumption

4.2	Description	Unit	Value
Energy consumption and utilization efficiency			
4.2.1	Energy consumption vs. input (t of raw hide)	GJ/t	
4.2.2	Energy consumption vs. output (wet blue/crust/finished leather)	MJ/m ²	
4.2.3	Energy used for heating/cooling of store rooms and offices	GJ/year	
4.2.4	Total energy consumption over a certain time span (working/non-working day, month, year)	GJ/day	
4.2.5	Share of own energy produced (digestion, incineration) vs. total energy consumption	%	
4.2.6	Energy consumption for effluent/waste treatment vs. raw hide input and/or effluent volume (see also Chapter 10)	GJ/t or m ³	
Recommendations:			

QUALITY ASSURANCE

Possibly the most complex challenge for every leather manufacturer is to maintain the capability to supply the end-user with a consistent product despite the fact that the properties of the main input, the raw hide, vary considerably even within the same weight,

breed and sex category. Consistently adhering to delivery schedules is of equal importance with providing the demanded quality of product. Therefore, the continuous and very careful monitoring of all process parameters is a *conditio sine qua non* for achieving and maintaining the desirable quality level and consistency.

Good monitoring and control are also the indispensable components of cleaner technologies; strictly applied and followed they reveal that in most tanneries actual consumption of chemicals exceeds the theoretical, recipe-based computation, at times by as much as 10-15%. There are many possible sources for this difference, the most typical being material handling waste, overdosing (including over-spray in finishing), low exhaustion and probably the most crucial, the reprocessing/refinishing of batches not meeting specifications.

Additional labour, energy and time losses, possibly compounded by the diminished trust by the customer for failing to deliver the goods on time, are further undesirable consequences of reprocessing. To quote an experienced leather industry specialist: **“The costs of chemicals, labour, rejects, re-works, energy, pollution control/treatment are amplified by waste.”**

What is more, the unavoidable wastes due to lower reactivity of some processes/chemicals (e.g. vegetable tanning, retanning with syntans, fat liquoring and dyeing), as well as some general chemicals (e.g. acids) not absorbed in the process, add to the amount of chemicals which end up in the drain instead of the leather, thereby increasing the pollution load.

Modern controls in leather manufacturing, **preferably partially or fully automated**, monitor and correct parameters such as weights, volumes, pH, temperatures, run-times, preparation and dosing of chemicals, rinsing as well as leather properties, comparing and correcting them to coincide with standard/reference values in order to reduce deviations and ensure that the final product complies with the given specification.

Listing all quality parameters that need to be controlled and monitored exceeds the purpose and concept of this paper, but a summary is provided in the chart below. The quality/performance aspects of requisitioning and marketing activities are not included here.

Check list 5: Quality assurance, reprocessing

5.	Parameter/Component	Yes	No
5.1	Raw hide/skin: origin, preservation, sex, weight, grade, thickness, trimming, health inspection if applicable		
5.2	General and specialty chemicals: material safety data sheets, active substance content, shelf life, properties specific for a particular chemical		
5.3	Processes: weights and volumes, run times, temperatures, pH, including specific controls (e.g. delimiting, bating, neutralization level)		
5.4	Mechanical operations: performance specific for a certain machine and operation such as pressure and dewatering effect for sammying, thickness and accuracy for splitting, uniform coating and minimal losses in spraying, etc.		
5.5	Final product – wet blue, crust, finished leather: laboratory tests as per the INTERNATIONAL UNION OF LEATHER TECHNOLOGISTS AND CHEMISTS SOCIETY (IULTCS) physical (IUP), chemical (IUC) and fastness (IUF) norms and procedures and		

5.	<i>Parameter/Component</i>	Yes	No
	customer specifications		
5.6	Additional analyses for presence of banned and/or potentially hazardous chemicals (e.g. banned amino dyes)		
5.7	Infrastructure, auxiliary equipment: power, steam, compressed air sources and supply lines, stores, vessels under pressures, vehicles, etc. in conformity with official standards		
5.8	All staff welfare related matters such as catering, hygiene, resting and recreational facilities, transport, etc. complying with highest standards		
5.9	All tannery operations and activities duly reflected and recorded in easily accessible and retrievable documents		
	Laboratory control (a few examples)⁷		
5.10	Chrome content in the fresh main tanning float		
5.11	Chrome content in the main tanning spent float		
5.12	Chrome content in the retanning float		
5.13	Chrome content in the spent retanning float		
5.14	Chrome content in the waters from sammying		
5.15	Chrome content in the combined chrome bearing streams		
5.16	Chrome content in the combined tannery effluent		
5.17	Chrome content in wet blue/crust/finished leather		
	Rework/reprocessing/delivery time		
5.18	A (software) programme regularly compares the amount of chemicals purchased/actually used vs. theoretical, recipe based quantities		
5.19	A (software) programme regularly compares the excess chemicals used against the (maximum) limit set		
5.20	Actual exhaustion rates (e.g. for retanning agents, fat liquors, dyes) regularly compared with the targets set		
5.21	Number of batches reprocessed regularly compared against the ceiling set		
5.22	Number of customers' claims regularly compared against the (maximum) limit set		
	Failures		
5.23	Records kept about all technical and delivery failures together with critical assessment of their causes orderly maintained		
5.24	Records kept about the nature and effect of corrective actions taken (e.g. technical modifications, training, new recipes, etc.)		
5.25	Critical evaluation of failures conducted periodically (e.g. weekly, monthly)		
5.26	Assessment of the impact of preventive actions carried out regularly		
Recommendations:			

OCCUPATIONAL SAFETY AND HEALTH (OSH), MAINTENANCE

The main factors affecting health hazards and safety at work are machines and equipment, chemicals, working environment and conditions, and people. As a rule, OSH standards in a

⁷ *Laboratory monitoring and control of effluent treatment parameters (BOD, COD, TKN, sulphide, TDS, DO etc.) is another rather complex area.*

tannery are among the best visual indicators of its overall performance. More information is given in the OSH chapter; there is also a detailed paper *Occupational safety and health aspects of leather manufacture*, J. Buljan, A. Sahasranaman, J. Hannak, 1999 posted on www.leatherpanel.com. Thus, the table below is only an extract to serve as a handy example.

Check list 7: Occupational safety and health at work, maintenance

7.	Component	OK	Not OK
	Chemicals, general		
7.1	Material safety data sheets of all chemicals readily available		
7.2	Staff familiar with the basic content of data sheets		
7.3	All chemicals stored in orderly manner		
7.4	All containers correctly labelled		
7.5	Staff familiar with the meaning of signs and symbols, risks and first aid, especially concerning hydrogen sulphide (H ₂ S)		
7.6	Transfer and dosing of chemicals ideally in fully closed systems		
7.7	Concentration of (hazardous) chemicals levels below TLV in terms of both TWA and STEL		
7.8	Hazardous/inflammable chemicals stored in proper, prescribed manner		
	Etc.		
	Machines, general		
7.13	Machine's position allows smooth work flow and maintenance		
7.14	Preventive/regular maintenance and spare management in place		
7.15	Active safety devices (pneumatic, ultrasonic, optical or electrical) installed and functioning		
7.16	Electrical installation in accordance with high safety standards in all respects (corrosion, earthing, water, gases, sparking, etc.)		
7.17	Passive safety devices (guards, fences) on moving parts (gears, belts, etc.) installed, firmly anchored		
7.18	Noise, vibration, radiant heat, dust, gas/vapours levels in accordance with high legal standards		
	Etc.		
	Workplace environment and conditions		
7.24	Even floors with slip-proof surface, covered floor openings		
7.25	Drains covered with corrosion resistant grates		
7.26	Safe and clearly marked transport and passageways		
7.27	Adequate lay-out/spacing, room lighting, ventilation, humidity		
7.28	Fixed and portable hydrogen sulphide (H ₂ S) and ammonia (NH ₃) meters used in hazardous areas (beamhouse, waste treatment)		
7.29	Personal breathing apparatuses readily available in higher risk areas		
7.30	Safety and health protection signs and instructions visibly displayed		
	Etc.		
	Machines, example of specific cases		
	Drums		
7.36	One-metre space provided in the rear and sides of the drum		
7.37	Fixed barrier guards installed in the rear and side areas to prevent access to drum and drive while the drum is rotating		
7.38	Removable, interlocked safeguard installed at the front, which automatically stops rotation of the drum if not in place or opened		

7.	Component	OK	Not OK
7.39	All operating control switches marked in local/operator's language and/or colour (e.g. OFF – red, ON – green)		
7.40	The control switches installed close to the drum but away from any moving part		
7.41	The electrical starter of the motor will not restart on its own when the supply is restored after a power failure		
	Etc.		
	Automatic spraying machine		
7.57	The machine, including the drying tunnel, positioned in a way allowing sufficient space for operation, maintenance and repair		
7.58	Fixed guard and covers installed and in place to prevent the possibility of accident/injury by contact with moving parts: pulley, drive, belts		
7.59	(Glass) panels of the spraying compartment in place and in good order, tightly sealing the compartment		
7.60	Spray vapours and mist efficiently ducted out from the spraying boot and drying tunnel and subsequently efficiently removed/neutralized		
7.61	Spraying area regularly checked for concentration of harmful evaporations		
7.62	Firefighting equipment suitable for inflammable solvents (class B fire) regularly checked and readily available		
7.63	All operating control switches marked in local/operator's language and/or colour (e.g. OFF – red, ON – green, EMERGENCY STOP –yellow/red)		
7.64	All electric motors and enclosures in the spraying area enclosed and explosion-proof (EX rated)		
	Etc.		
Recommendations:			

HUMAN RESOURCES, STAFF WELFARE, CORPORATE SOCIAL RESPONSIBILITY, CSR

Not only the educational background and skills of employees, but also their motivation and commitment are key ingredients of any successful operation. A dedicated and loyal workforce is the result of not only appropriate remuneration, but also fair treatment, recognition, encouragement of initiative and innovation.

While this sounds obvious, in reality that is not always the case. In some developing countries in particular, too often the importance of attracting, retaining and remunerating the technical staff (skilled operatives, supervisors, technicians, engineers) is not fully appreciated.

Check list 10: Human resources, staff welfare, CSR

10.	Description/Component	Yes	No
10.1	The company is able to attract and retain the best skills		
10.2	Competitive remuneration linked to both output and quality		
10.3	The company offers an attractive social package (insurance, health and		

10.	Description/Component	Yes	No
	pension benefits)		
10.4	The company offers equal opportunities for all staff/both genders (pay, promotion, training)		
10.5	A stable system for continuous systematic training of staff of all profiles and levels in place (courses, workshops, team building, etc.)		
10.6	The level of absenteeism lower/higher than in similar companies or against the target set (e.g. 5-6%)		
10.7	Exposure of key personnel to global and prevailing trends and developments in the (sub)sector: fairs, exhibitions, machinery innovations, study tours, visits		
10.8	A transparent and motivating system of rewarding new ideas, savings and innovations in place		
10.9	Participation in national and international sector associations (e.g. IULTCS, ICT), meetings; subscription to technical periodicals		
10.10	Appropriate and sufficient toilets, showers; canteen, crèche, ambulance, postal services; recreational area		
10.11	Where relevant, proximity of place(s) for religious service		
10.12	Share of training, welfare, CSR costs in the overall production costs stable or increasing		
10.13	Maintaining a high CSR profile; continuous dialogue with the local community, supporting its activities ⁸		
RECOMMENDATIONS:			

A company maintaining a continuous dialogue with the local community will be in a better position to resist unfounded pressures of local politics that, regrettably, often (mis)use environmental issues for their own purposes.

3.3. Conclusion

Environmental Management System (EMS) in a tannery serves as a very practical management tool for systematic and coherent strategic planning, implementation, verification, review and improvement of environmental and occupational safety and health at work place (OSH) aspects of its operations. This approach is in sharp contrast with *ad hoc*, crisis management and nearly spontaneous reactions to pressures by legislative enforcement authorities or by the general public. Genuine support and commitment by top management, team work with all benefits of close interaction of all organizational units, circulation of information, continuous training at all levels, and accountability and responsibility in defining and meeting specific targets (e.g. waste minimization/recycling/reuse) are essential components of a good EMS.

Introducing cleaner technology methods is certainly a dynamic and continuous process. One of the key tasks of any Environmental Management System in place in a tannery is to keep pace with the latest scientific developments and techniques, and acquire, adapt and implement them to suit local conditions.

⁸ Not to be confused with regular promotion and marketing activities.

4. WATER MANAGEMENT

The largest material input in leather processing is water, its consumption by weight is by far higher than any other component of the production process, including the main raw material, hides/skins themselves.

Water consumption consists of two main components: water needed for physical-chemical processes (process water) and water needed for cleaning, energy generation, waste water treatment and sanitary purposes (technical water). The focus here will be on the process water.

Variations in water consumption presently range from less than 15 m³/ton to more than 80 m³/ton of wet salted hides for nearly identical raw material category and basically the same type of finished leathers produced (e.g. shoe uppers). The latter, wasteful scale of water consumption still persists in some pockets where water is drawn from rivers, lakes or drilled wells with hardly any control and virtually free of charge.

The following estimates provide a realistic picture about water consumption in the conventional process, bovine hides.

i) IULTCS/Environmental Commission, IUE

Table 3. Typical pollution values in conventional tannery processes

	Water
Values per t of rawhide	m ³ /t
BOVINE SALTED RAW HIDE PROCESS	
Beamhouse (soaking to bating)	7/25
Tanning operations	1/3
Post tanning	4/8
Finishing	0/1
TOTAL	12/37

ii) EU-BREF, 2013

Table 4. Water consumption in process stages (conventional processing)

Process stage	Waste water discharge per unit of raw hide (m ³ /t)
Total to end of beamhouse	20 – 25
Total to wet blue	21 – 28
Total to finished leather	34 – 40

4.1. Water saving strategies

The growing water shortage, especially in arid regions, compounded by increasing charges as well as changes in perception of water as a freely available resource to one among chemicals essential for the process has brought about a dramatic reduction in water usage. On the global scale in the past 25 years water consumption for production of leather from bovine hides has declined by about 37%: from approximately 60 m³/ton of hides to 38 m³/ton (Knoedler, 2014).

Water use can be reduced at many points of the leather making process; and good water management should be seen as one of the key components of modern leather technology and the overall factory management.

In addition to reducing pressure on the water supply, water conservation has other important benefits. Lower water consumption implies smaller sized plants (especially treatment plants), lower consumption of chemicals, and, as a rule, lower operating costs, including the cost of energy.

However, contrary to some (mis)perceptions, reduction in water use does not reduce the pollution load *per se*; the same amount of pollutants is just concentrated in smaller volume.

There is a considerable scope for simple, low cost and yet effective ways to save water and reduce manufacturing costs even in a tannery following conventional technology. The first, mandatory steps include:

- Switch from continuous, “running water” to batch washes;
- Strict, ideally automated control of the volumes of processing waters;
- Recycling and reuse of individual process liquors (e.g. lime washes for the first soak);
- Modification or replacement of existing vessels and some equipment with more efficient (e.g. drums & driving gears) making them suitable for low/short floats;
- Close inspection of installation, pipework and equipment for any losses and leakages;
- Close assessment and reduction of use of technical water (fleshing, cleaning, etc.)

Measurement of water consumption and establishment of water balance

The first step in assessing the actual water consumption at each process step is to check how much water is used per unit of raw material processed. The quantity of incoming water and water leaving the tannery should be measured and compared. If the difference between incoming and outgoing water is more than 10-15%, then there are some “invisible” losses in the system; usually it is through valve and pipe leaks, especially in the old, underground pipe-work. Verifying the accuracy of the readings should not be overlooked either.

The next step is normally to introduce regular i.e. daily/weekly/monthly water audits. The current period water use has to be compared against production for the identical period in the past; the actual consumption also has to be compared with the theoretical/recipes projections. Monitoring and control for each department or section or even machines greatly facilitates spotting the sources of excessive consumption and/or losses.

Tip: The easiest way to identify leakages is to check water meters while the factory is non-operational e.g. during weekends.

Obviously, water consumption always needs to be matched with and computed per unit of raw material processed (input weight of hides and skins, pelt, wet blue, crust, etc.) as well as per unit of final products (e.g. area of leather in m²); the assessment should also include at least the amount of chemicals used.

4.2. Some practical examples of water saving measures

4.2.1. Washing

Water used for washing in various steps represents around 30 -50% of all water used in the process and that is why it is the very first target within the water savings measures. In practice the main cause is washing with running water washes i.e. with rotating drum, slatted door and open water valve. This way it is very difficult to control the process and the flow rate. Instead, batch washing with a closed door can bring about water savings of more than 50%.

Tip: An easy way to check washing efficiency is to measure the concentration of certain chemicals, for example, salt content in the float.

Additional water reduction and more uniform quality is achieved by thorough drainage after each process step, including washes; float residues in vessels require more water for washing. False perforated bottom ends in paddles or plastic/wooden perforated sectors significantly improve drainage of floats.



Figure 6. Plastic sectors inside the drum, fixed with stainless steel screws

Figure 7. Installation of wooden sectors to improve drainage of floats

Recent developments in processing vessels (cross circulation) facilitate better washing as well as thorough drainage.

4.2.2. Low/short float techniques

There is no general rule on float length and each process needs to be carefully assessed in order to achieve the best quality vs. optimum use of water, chemicals and energy. Short float means a higher concentration of chemicals, rapid penetration and higher exhaustion rates. Strict monitoring and control of the key parameters such as pH, temperature and time will further contribute to better uptake of chemicals and reduce the amount of water needed for washing. Consistent quality and reproducibility and avoidance of reprocessing are further benefits.

However, high efficiency in any process does not necessarily result in good quality. Excessive float reduction in some specific processes can result in grain defects and damages due to mechanical action. While some modern vessels, new materials and techniques reduce this danger, this risk should be always considered.

Obviously wherever possible pits and/or paddles which utilize 300% – 1000% floats should be replaced with drums.

Tip: Paddles and pits are needed for certain processes such as the first soaking of dried skins, processing of long-wool and some special skins.

4.2.3. Recycling and water reuse

Many relatively clean rinse and wash waters can be recycled to other processes where the low concentration of residuals chemicals will have little adverse impact; typical examples of water reuse:

- Part of the main soak can be reused into the “dirt soak”.
- Part of the second lime wash to start a new lime liquor; alternatively it is used for the first wash.
- Deliming liquors (after pH adjustment with drained pickle float), for liming. Caution, risk of forming H₂S!!!
- Drained pickle float is used for pH adjustment of deliming liquors.
- Drained pickle float for building up of the new pickle (as a rule it is started by adding salt and sodium formate, followed by first acidification with formic acid and the final pH adjusted with sulphuric acid).
- Recycling of spent tanning floats (Covered in detail in Operations in the tanyard chapter).
- Water from wetting back wet blue leather is mixed with fresh water for the next wetting back batch.
- In some cases (processing of fresh hides and segregation of streams) fully treated effluents can be reused for the dirt soak.

Generally, each reuse should be properly tested prior to reuse in full production.

Reusing and float recycling *per se* are quite simple especially in new tanneries where it is expected that sufficient space is left to accommodate screens (e.g. self-cleaning fine filters), storage tanks, skimming devices, pumps and piping with good access for maintenance and repairs; this may be quite difficult in old tanneries with limited space. Obviously, recycling systems require higher levels of supervision.

Recycling of process liquors e.g. liming, tanning is an additional way of reusing such effluents and residual chemicals to reduce water requirements and pollution from the process and it should be adopted whenever feasible. However, in practice, float recycling is as often as one would expect it. The explanation can be that i) as said earlier, it requires additional space for storage tanks and/or ii) the risk that it may affect the leather quality prevails over possible savings in water and chemicals.

4.2.4. Reduction of unnecessary material

Green fleshing in addition to opening up of the hide structure and better penetration of chemicals during soaking and liming, reduces the water needed for soaking, liming and washing after liming up to 15%.

Lime splitting allows trimming away by-products (e.g. shoulders, flanks, splits) prior to further processing and reduces or minimizes water and chemicals use.

4.2.5. Fleshing, vacuum dryers, finishing

In some tanneries fleshings are collected and transported with the aid of water and in some cases water used can reach 1 – 2 m³/t of w.s.w. Use of fleshings pumps with an efficient collection system can effectively reduce water consumption for this operation.

Old vacuum dryers are typical examples of “hidden” and often overlooked water consumers; similarly, while water consumption in the finishing department is comparably very low, scrubbers and chemicals container cleaning may use more water than actually needed.

Finally, floor cleaning and leaking valves in sanitary units also need appropriate water consumption control.

4.3. Water consumption targets

It is important to emphasize that for many technical reasons (raw material, technology, leathers produced, climate, etc.) it is not possible to set a kind of norm regarding water consumption. Thus, the following values are primarily for general guidance in establishing specific targets in individual tanneries.

i) UNIDO, Benchmarking

WATER CONSUMPTION	Not exceeding 25 m ³ /ton of wet salted hide, including sanitary water.
--------------------------	--

ii) EU- BREF, 2013

Table 5. BAT-associated consumption levels for water for the processing of bovine hides

Process stages	Water consumption per ton of raw hide ⁽¹⁾ (m ³ /t)	
	<i>Unsalted hides</i>	<i>Salted hides</i>
Raw to wet blue/white	10 to 15	13 to 18
Post-tanning processes and finishing	6 to 10	6 to 10
Total	16 to 25	19 to 28

⁽¹⁾ Monthly average values. Processing of calfskins and vegetable tanning may require a

iii) UNIDO, Ludvik

Table 6. The theoretically lowest water consumption, stagewise

Process stage	Waste water discharge m ³ /ton of w.s. hide
Soaking	2
Liming	4.5
Deliming, bating	2
Tanning	0.5
Post-tanning	3
Finishing	0
Total	12

4.4. Rainwater management

The aim here is twofold:

- i) To minimise the amount of rainwater which becomes contaminated and requires treatment as the main effluent
- ii) To maximise the amount of rainwater collected separately to be used either in the leather process itself or for cleaning.

The main source of rainwater contamination is paved yards with residues of spills of chemicals and that is why their area should be as small as possible and the inflow/outflow blocked by physical barriers. At the same time, it is recommended to install rainwater separators for rooftop rainwater.

Figure 8. One of the three reservoirs of rainwater at Packer Leather, Narangba, Queensland, Australia



Source: World Leather, Oct/Nov 2014

4.5. Banned substances in tannery effluents

In addition to control of traditional parameters such as COD, BOD₅, TKN, chrome, sulphide, etc., an important trend in European legislation is stricter regulation of the presence of biocides and pesticides in tannery effluents such as DDT, hexachlorohexane, aldrin, dieldrin, endrin, isodrin, naphthalene, etc. especially since some prohibited substances, notably organochlorine compounds, are stable enough to survive waste water treatment processes.

Only registered and approved biocides can be used and their choice is becoming more and more limited; it is not surprising that it is claimed that some biocides and pesticides prohibited in Europe may be imported with hides and skins from countries where their use continues.

Virtually all pesticides found in the tannery waste water are residues of pesticides used to treat live animals whereas biocides are regularly used in preservation but also in soaking, pickling, tanning, and post-tanning processes.

Bibliography

Knoedler, J. (2014). *Management of water-use in tanneries*. Retrieved July 14, 2014, from Nothing to Hide: http://www.nothing-to-hide.org/LeatherFacts/Water:_reduce,_reuse,_recycle/Summary

5. RAW MATERIAL PRESERVATION, SALINITY

Although the preservation of raw hides and skins, be it of short- or long-term nature, normally takes place before they enter a tannery, the method of preservation is of such impact on its overall environmental performance that it needs to be considered more closely.

Raw hides and skins are subject to autolysis (i.e. degradation due to activity of enzymes within the cell) and attack by microorganisms present in the air, hair, dung, floor, etc. The flesh side is more vulnerable to attack than the grain. The pace of both autolysis and bacterial degradation increases with temperature. Preservation protects the raw material by:

- i) inhibiting enzymes' activity
- ii) arresting the growth of microorganisms

Short-term preservation can last up to a maximum of three weeks, the methods applied are:

- chilling
- icing
- application of biocides

or the combination thereof.

Long-term preservation methods practised are drying (mainly skins) and salting/brine curing, which can preserve up to six months; the latter method dominates in (inter-continental) trading.

Short- and long-term preservation cannot be compared directly as they are not equally applicable.

Preservation is usually carried out at the slaughterhouse but it can also take place at the hide dealer's premises, at the hide market or even in a tannery located close to the slaughterhouse. In certain cases, it might be necessary to repeat the step at the tannery, e.g. if chilled hides are salted for longer storage or if the initial salting was not sufficient to dry the hides.

5.1. Traditional preservation methods

Drying

Moisture removal kills and/or inactivates bacteria and enzymes. If too slow, decomposition sets in, if too fast or in the sun, the fibre network is damaged, proteins denature. While the percentage of skins preserved by drying is substantial in the case of hides, it is insignificant.

Salting

Salt inhibits the growth and bacterial activity by lowering the moisture content in the raw stock. After flaying hides and skins are firstly cooled, spread out (hairside to the floor),

uniformly covered with salt, stacked, sandwiched with more salt and left to drain for about a week until solid salt indicates the saturation point. Eventually hides are resalted and packed for long-term storage and/or transport. The total amount of salt (sodium chloride) applied is usually about 40%, but with resalting in the dealer's or even tannery premises it may reach 50% on the fresh (green weight).

Preservation technique by brining in saturated salt brine is mainly used in the USA: hides are placed in raceways and made to swim by mechanical means. Usually, after brining some more salt is sprinkled for safety. Brining is faster than conventional salting; the salt solution fully penetrates within 12 hours. The brine is continually recharged with salt plus a preservative and reused indefinitely. There is always excess brine to be treated or evaporated. Brining in drums is also possible.

Figure 9. Brined and salted USA hides in Xuzhou Nanhai Leather Factory, China



World Leather Oct/Nov 2012

Some Australian hides and most sheepskins are drum salted with no added water which minimises salt use and effluent, drums, mixers and processors are used with about 20% salt on hide weight; more is required if the hides are wet. Air drying of sheepskins in Australia in open sheds using solar and wind energy is a good example of environmentally friendly and salt avoiding curing. Regrettably, increasing numbers of skins are now salted for processing with the wool on.

Preservation by salting is not quite foolproof; the rawstock can be contaminated by slow-growing halophilic bacteria causing red and purple heat. That is why, especially in cases of longer transportation and storage (possibly under unfavourable conditions), selected biocides may be included in the salt. Several proprietary products are on the market. They are based on potassium dimethyldithiocarbamate (> 0.3 % hide weight for brine curing), p-dichlorobenzene, sodium silicofluoride, and borax. Also, boric acid and sodium metabisulphite might occasionally be used.

Hide dealers stock hides and skins to accumulate adequate quantities of the same origin, weight category, quality, etc. but also for speculative reasons (rising price trends). Tanners, on the other hand, stock the raw material to optimise the consistency of their batch processes and the quality of the finished leather to meet the customer's specifications.

Total Dissolved Solids (TDS), mainly chlorides and sulphates (colloquially salinity) in effluent is the major environmental concern in arid and semi-arid regions of the world as it makes the receiving water recipients (rivers, lakes) unfit both for livestock watering and for irrigation. High salinity in irrigation water causes high osmotic pressure which results in reduced water availability and retarded plant growth of crops. Also, while the presence of calcium and magnesium ions in tannery effluent that ends up in irrigation water stabilises the soils, high concentrations of sodium can cause dispersion of clay.

Table 7. Preservation by salting

Advantages	Disadvantages
<ul style="list-style-type: none"> • Widely available at modest cost • Simple, easy to apply • Very reliable if carried out properly • Very limited capital investment • Facilitates elimination of interfibrillary, non-collagenous matters in soaking and preparation for liming/tanning • Allows long storage & transportation, (large) stock holding, more uniform lots both for sale and processing 	<ul style="list-style-type: none"> • More expensive than fresh or icing • Investment cost high if mechanised (e.g. brining) • Disposal of polluted/excess salt a problem • Heavy pollution of waste water (salinity), not to be removed by normal treatment; because of extremely high energy costs Reverse Osmosis (RO) normally not affordable.

While a certain percentage emanates from other operations such as pickling, deliming, tanning and wet finishing, the main source of TDS, especially of sodium chloride, is salt from preservation. Unfortunately, TDS in tannery effluent cannot be removed by conventional treatment (reverse osmosis, RO considered excessively expensive), **the environmental damage caused by salting more and more prevails over its positive aspects.**

Worldwide, based on approximately 10 million tons w.s. weight processed and computing the salt at the level of 40% of fresh hides & skins' weight and after allowing for hides processed unsalted, it can be estimated that at least 3.0 million tons of common salt per year is discharged into water recipients.

5.2. Alternative, more environmentally friendly preservation methods

5.2.1. Short-term preservation

In addition to the drying mentioned earlier, the only alternative to salting is the processing of fresh (green) hides and skins i.e. short-term preservation by cooling, using crushed ice or refrigerated storage, by using biocides and the combinations thereof.

Rapid post-mortem cooling is essential for short-term preservation. It can be carried out in a few ways:

- Immediately after flaying hides are spread on a clean smooth floor with the flesh side down;
- Immediately after flaying hides are put into a mixer containing chunks or cubes of ice;

- Immediately after flaying hides are passed through a tank of glycol-cooled water and following with ice added to the storage container;
- By using CO₂ snow. Very convenient where cold storage facilities are already available; with good ventilation there is virtually no health or safety risk.
- By using refrigerated storage units: the hides must be hanging and without touching each other.

The cooling chain must not be interrupted during transport and storage. The temperatures to which hides and skins should be chilled depend on the required duration of preservation. In moderate climates the maximum time span between cooling down and processing for fresh, unchilled hides is 8 – 12 hours. If the refrigeration temperature is reduced to 2⁰C, hides and skins can be stored for three weeks without suffering damage.

The number of tanneries in Europe which process fresh hides is growing due to increased environmental pressure; biocides are not used in the preservation of raw bovine hides. Some of those used in the past like PCPs, DDT and HCH are not permitted anymore. On the other hand, distances and infrastructure allow fast movement of goods within Europe. In Brazil, with huge feed lots and large scale abattoirs, only fresh hides are processed. However, there are claims that more biocides are needed in the course of processing fresh hides; also, the soaking of fresh hides requires some adjustment in the process.

The investment cost of ice-making machines is generally lower than for chilling units and cold stores. The technique is considered economically viable when the cooling chain is no longer than two days.

Table 8. Short-term preservation

Advantages	Disadvantages
<ul style="list-style-type: none"> • No salt in the waste water from soaking • Reduced soaking time & lower energy consumption • Water consumption 2-3 m³ per tonne less than for salted hides • Some claim that the hides are softer, more regular neck parts, easier to process • Better yield (1 – 1.5 %) also claimed; • Lower stock holding, lower working capital needed 	<ul style="list-style-type: none"> • Limited time available between slaughter and processing: ideally 5 -7 days, maximum three weeks • Difficult to build homogeneous batches be it in the abattoir, by a dealer or in a tannery • Process adjustment needed for unsalted hides • In practice contingency salting of excess raw material in the tannery may be required • No flexibility to buy raw material and accumulate the stock when prices are lower • Transport costs high(er) if refrigerated trucks are used • High energy consumption/costs for refrigeration • Noise from engine-powered refrigeration units • Hard to organize in countries without large abattoirs and with poor infrastructure • Not suitable for international - transcontinental trade • Higher risk of deterioration, damage

At the moment it seems that the target with biocides is to ensure one week preservation without salt or drying; in rural areas of some developing countries up to three weeks are needed. However, there are concerns about uneducated people using potentially hazardous chemicals with limits on our ability to train or manage applications.

Biocides are hazardous – they need to be as they are controlling living things – but it is important to consider “sustainable” use and not just reduction. Using less is not necessarily better; if the sufficient amount is not used, hides are not preserved and the consequences are well known. Substitution with “greener” biocides is not necessarily better either as less hazardous substances typically correlate with weaker biocides so that higher amounts/percentages are needed. Also, it is known that it is not the inherent hazard but the level of exposure (volume and time) that is crucial.

5.2.2. Preservation with polyethylene glycol (PEG)

The concept of using polyethylene glycol (PEG), a polyether compound⁹, considered long ago (USA patent, 1964) has been revisited recently and an alternative low salt bovine hide preservation using PEG in the presence of crude glycerol and sodium carbonate as well as sanitizing agents for temporary preservation has been proposed.

It is reported that with the addition of PEG (and crude glycerol, sodium carbonate and sanitizing agents) the amount of salt used for brining can be reduced to 25% of the commonly used amount. It is also claimed that there is no increase of ash content, rehydration before processing is faster and the overall mechanical properties (softness in particular) of crust leather produced is superior. What is quite important is that the cost is lower than with conventional salt preservation.

Nearly in parallel, an attempt has been made to lace the salt with PEG MW 2000 for preservation of goat skins. The following mechanism has been suggested:

Figure 10. Schematic representation of (a) dehydration process of hide matrix by PEG (b) rehydration process of PEG treated hide matrix

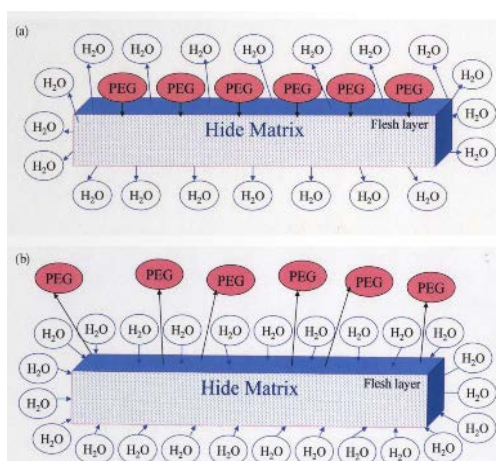

Source J.R. Rao at al. www.aaqtic.org.ar/congresos/china2009/oralPresentation/1-14.pdf

⁹ H-(O-CH₂-CH₂)_n-OH

Reduction in total salinity by about 40%, and technical and commercial viability are claimed.

As said earlier, some Australian hides and most sheepskins are drum salted with no added water which minimises salt use while effluent, drums, mixers and processors are used with about 20% salt on hide weight; more is required if the hides are wet. This process could possibly be combined with the low salt PEG system. Yet, it should be remembered that even with no float, a dry 25 kg hide produces 5 litres of brine during curing. Therefore, with hides there will be always be some effluent to be treated or evaporated.

It is not excluded that PEGs could be an answer for eliminating salt from skin preservation whereas for hides it might be too early for firm conclusions.

6. BEAMHOUSE

The traditional saying rightly claims that (good) leather is made in the beamhouse. Indeed, while the type of tannage (e.g. chrome vs. vegetable tanning) gives the leather its basic character, other properties like the fullness, elasticity and stretchability are defined by (fine) tuning of each of the beamhouse stages. The mistakes made here, be it excessive or insufficient liming/opening up, partial or full deliming let alone at the extremely sensitive and risky bating operation, are irreversible.

The aim of unhairing and liming is:

- Removal of hair and epidermis
- Removal of any residual interfibrillary components
- To open up the fibre structure in preparation for the tanning process

As usual, there are many variations of the nature and sequence of the processing steps. The next chart shows one of them with the alternative of fleshing before (“green”) and after liming.

Figure 11. The sequence of typical operations in the beamhouse

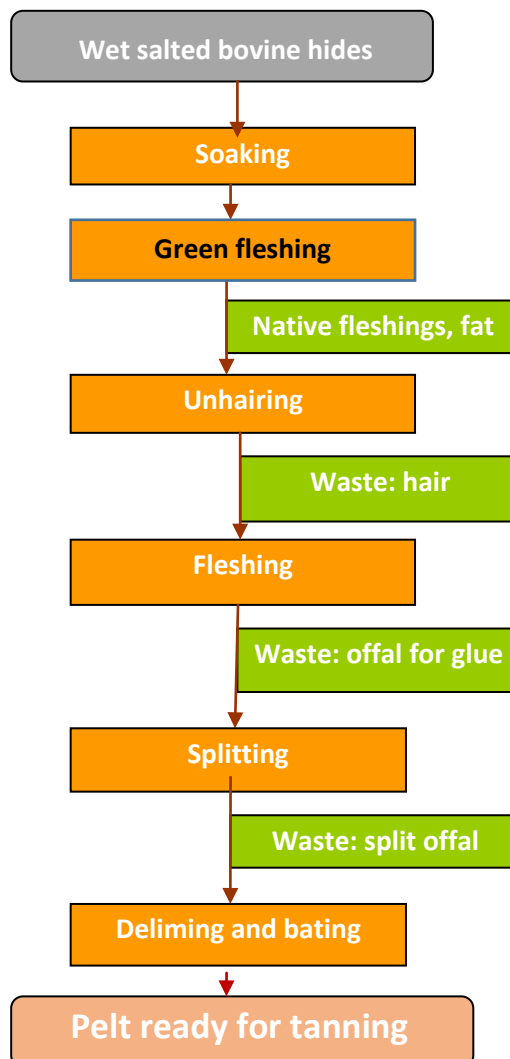

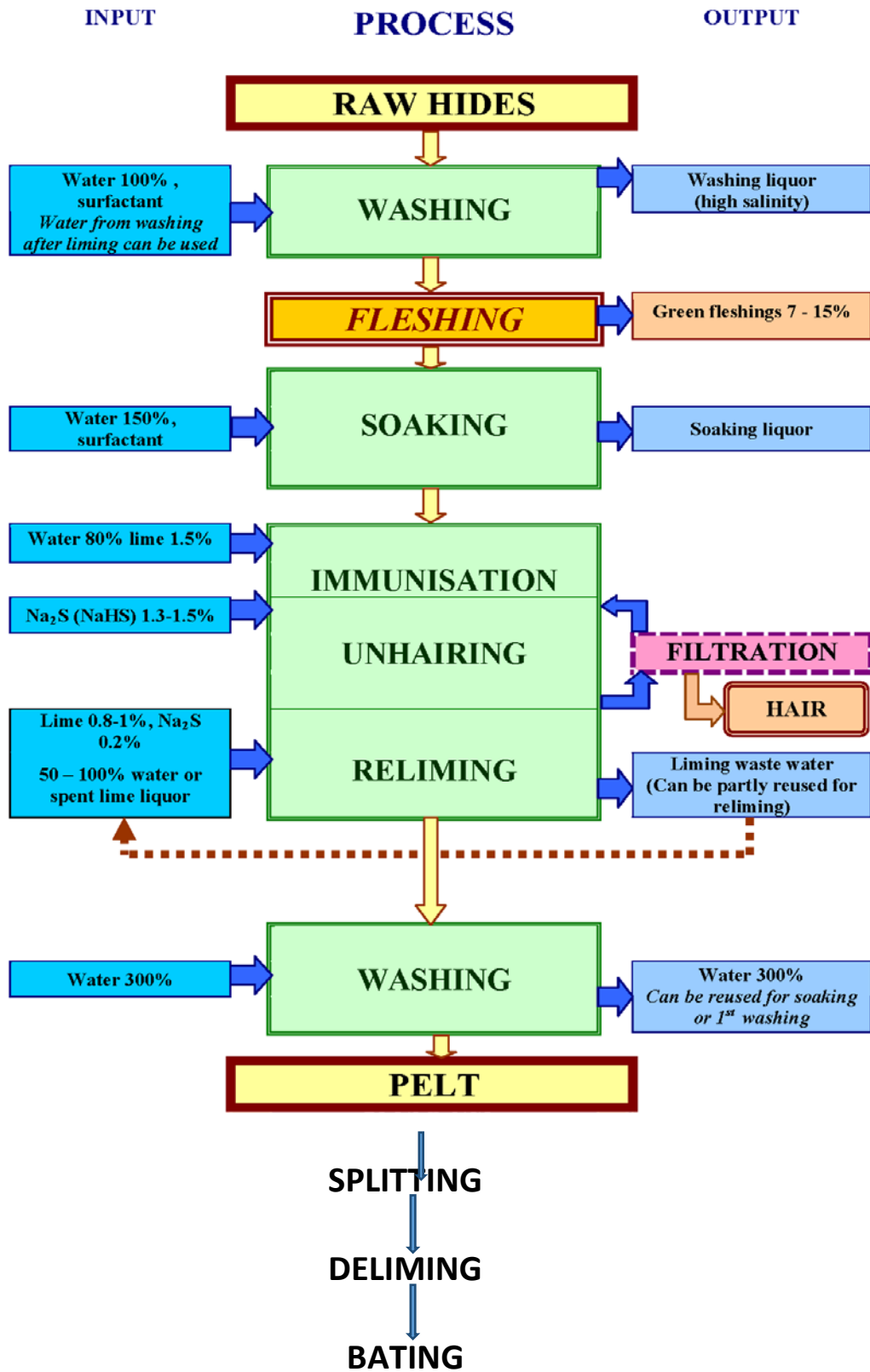

Figure 12. The process sequence, input/output in the beamhouse

The appearance, wastes and bad smell emanating from the beamhouse in old and inadequately run tanneries are the main culprits for the poor perception of the tanning industry as a whole.

The next figure shows the typical share of the beamhouse in the overall tannery emissions:

Figure 13. The share of the beamhouse in the total emissions, conventional process

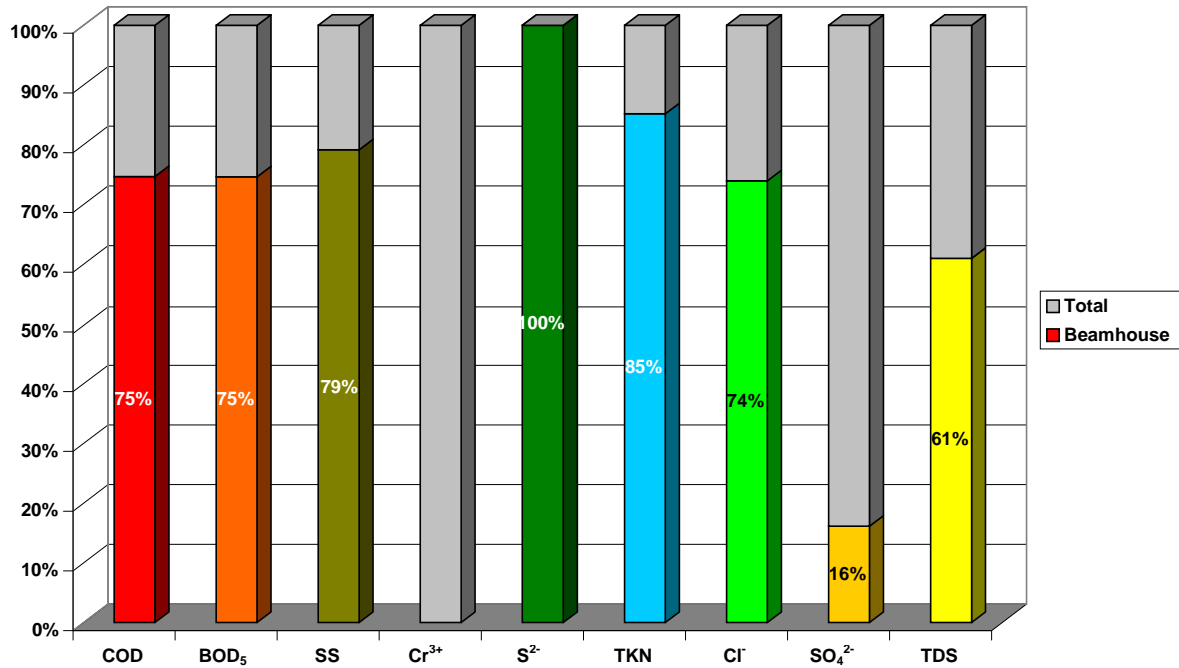

Chart by M. Bosnić

More about the main beamhouse operations is given in the following chapters.

7. SOAKING

The purpose of the soaking process is to bring the hides and skins to a condition very similar to that shortly after flaying. It is important to have them fully rehydrated and to remove any manure and dirt as well as the major part of any preservation substance used, usually common salt.

Furthermore, the major part of interfibrillary matter consisting of non-collagenous proteins (albumins, globulins and elastin) as well as glycosaminoglycans (di-/polysaccharides) are removed thus making the raw material better prepared for further processing.

The soaking process varies a lot to suit the type of raw material (cattle hides, sheep, goat skins) and the preservation method (fresh/chilled, brined, wet or dry salted, dried), the typical water consumption for the first („dirt soak“) being 200-300% on w.s. weight but in case of heavy contamination with dirt and manure adhering to hide, it can be much more; for the second, the main soak, normally it does not exceed 200%.

Figure 14. The share of pollution load emanating from the beamhouse operations, conventional process

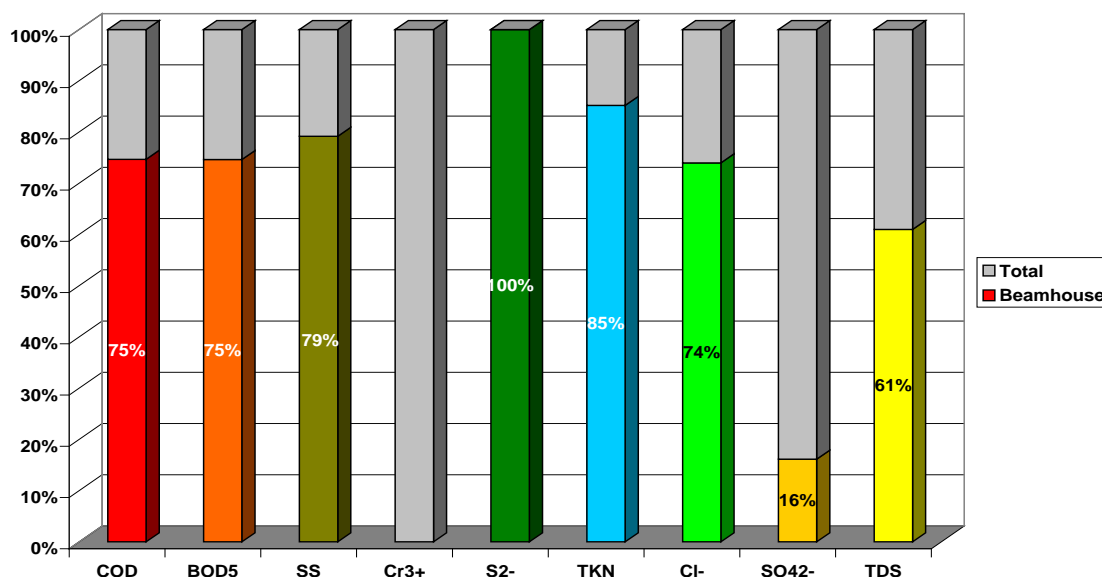

Chart by M. Bosnić

Soaking is carried out in low speed rotating drums (hides) or paddles (woolly and/or dried skins). In industrial types of leather processing, soaking in pits has been virtually abandoned. Rewetting is normally supported by applications of appropriate surfactants and sometimes enzyme based auxiliaries.

Alkalis (e.g. 0.2 – 2 g/l of sodium hydroxide), surfactants, and enzymes may be added to improve the efficiency of the soaking process; alternatively, weak acids such as formic acid or sodium bisulphite can be used for the same purpose. Biocides may be added to the float, normally at the rate of about 0.1 % of the w.s. weight to minimise bacterial damage and emissions of foul odours especially if the float temperature is higher than desired.

It is recognized that the soaking of fresh hides requires more intensive support (e.g. combination of soda ash, surfactants and proteolytic enzymes) to achieve the necessary removal of interfibrillary matter.

Generally, the thoroughness of the soak can be controlled by monitoring parameters such as weight gain, float density or removal of hyaluronic acid.

The waste soak liquor contains soluble proteins, suspended matters like dirt, dung and blood washed out from the hides, plus chemicals or residues of chemicals added such as alkalis, surfactants and biocides, giving a very high COD. However, worst of all, the salinity of the soak liquor varies from about 11,000 – 23,000 mg/l (as Cl⁻), see the previous chapter, Preservation.

7.1. Cleaner methods in soaking

Generally, the range of techniques to reduce emissions includes:

- ✓ Use of unsalted hides or skins, i.e. preserved by one of short-term preservation methods or drying
- ✓ Desalting and recovery of the used salt
- ✓ Use of clean hides or skins only
- ✓ Avoidance or substitution of hazardous, environmentally unfriendly substances
- ✓ Optimisation of water consumption and process control
- ✓ Green fleshing

The synergistic effect of combining 1.5 A direct and 2.0 A alternative current followed by 1 g/L bronopol (2-bromo-2-nitropropane-1,3-diol), a widely used antimicrobial agent for application in the hide soak liquors is still at the early research stage.

7.1.1. Green fleshing

Ideally, fleshing should be carried out in the abattoir itself thus facilitating the hide preservation and lowering the transport load but that is seldom the case.

Fleshing can be carried out at several stages of the process:

- green fleshing of fresh or chilled hides/skins
- green fleshing after (first) soak
- pickle fleshing (not common, mainly skins)

Tanners traditionally prefer fleshing after liming since in that condition fleshing is much easier.

Figure 15. Operating principle of the fleshing machine

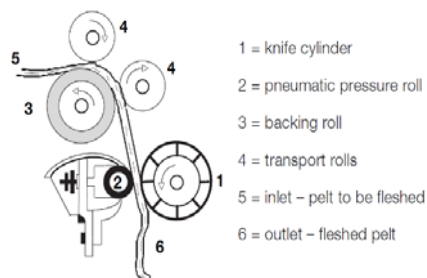

Source: BASF Handbook

Soaking of hides can be combined with “green fleshing”, usually after the dirt soak, especially if there is a good scope for utilisation of native fleshings (Green fleshings are free from liming and unhairing agents). Also, fleshing at this stage allows for a more rapid and uniform penetration of chemicals into the hide. For example, it is estimated that in the EU with green fleshing the consumption of chemicals and water in the beamhouse are reduced by 10 – 20%.

The basic machine for fleshing is the same for green fleshing and fleshing after liming. However, for green fleshing a demanuring cylinder needs to be installed. Also, green fleshing requires a well-set machine and experienced operators to avoid the damaging of hides as well as additional, after lime fleshing. Finally, green fleshing may not be viable with hides very dirty with dung without additional machine operation for dung removal.

Chemicals are not needed for fleshing. Sawdust may be used for a better grip on slippery hides; however, the amount of water used to wash away the fleshings from the fleshing machine is very often overlooked.

In the case of (heavier) European or USA hides about 10-40% of their weight is removed as wet limed fleshings; from lighter hides in developing countries it is considerably less. The amount of green fleshing is lower than that from lime fleshing.

Figure 16. Green fleshing in Australia



Source: C. Money, Australia

Disposal options greatly differ for green and limed fleshings and change in accordance with local legislation and availability of treatment facilities. Thus, they vary from rendering and landfill (after treatment) to production of hide glue or fat recovery. For example, in the EU the demand for green fleshings has suffered a great set back due to very strict recent regulations concerning animal by-products.

Figure 17. Through feed fleshing machine



Source: www.rizzi.it

7.1.2. Salt removal

Dry salted hides are opened out for processing in such a way that they are shaken or tumbled, so that loose salt crystals fall off and are not taken into the soaking process.

Figure 18. Drums for desalting of hides



Source: Rizzi (?)

World Leather, June/July 2009

Loose salt can be recovered by shaking. This operation can be carried out mechanically by using purpose-built equipment. Approximately 6 – 8% of the original salt content of the hide is eliminated, corresponding to about 5% of the total salt discharge from the tannery.

The overall salt emission level depends on the amount of salt dissolved in the raw material. About 5% of the salt usually found in the effluent streams is recovered. To test the efficacy of the technique, the treated batch of hides/skins may be shaken again and the loss in weight must not exceed 1%.

Salt disposal can be a serious constraint since its reuse for preservation or pickling is not possible due to bacterial contamination, landfilling is often forbidden (high solubility) and

the cost of salt recovery (purification by dissolving followed by evaporation) is high in comparison with the cost of fresh salt.

According to European experience, if all measures listed are taken, the emissions from soaking can be reduced to the levels shown in the following table.

Table 9. The scope for reducing emissions from soaking

Parameter per tone raw hide	Unit	Salted hides (calculated on salted weight)	Fresh or chilled hides
Water volume	m ³ /t	4	2
Total solids	kg/t	130	45
Suspended solids	kg/t	10	10
BOD ₅	kg/t	10	12
COD	kg/t	23	23
Total Kjeldahl nitrogen	kg/t	1.5	2
Chloride (Cl ⁻)	kg/t	55	5

Source: EU BREF 2013, Frendrup

Satisfactory results, especially in smaller tanneries, can be achieved with some improvisation as it was done under a UNIDO project in India: an existing old wooden drum 2.4 m x 1.8 m was modified by drilling holes of 85 mm in diameter and spacing of 130 mm and the drum fitted with an electrical motor of 3.75 kW.



Figure 19. Old wooden drum converted into a desalting drum

The best results were for wet salted lots of 250 - 400 kg at the speed of about 3 RPM (velocity 0.35 m/s), time 15 - 20 minutes. The amount of salt collected on the stone floor was about 5 -7% of the weight of raw stock during the dry season but less during the monsoon season.

Another method taken in a tannery was processing heavy buffalo hides. A brush-type desalting machine with a working width of 2100 mm, a cylindrical roller fitted with 5 nylon brushes, the width of each brush 125 mm, the speed of the brush roller 400 RPM and a 3.7

kW motor was installed. The salt on the flesh side, removed by the bristles of the nylon brushes dropped down a sloping wooden plank to the rear of the machine.

Figure 20. Brush type desalting machine



Finally, to reduce the strain of pure manual hand-shaking, a simple wooden frame (750 mm x 750 mm standing at 750 mm) that can be easily lifted and shifted was designed and made from local wood.

Figure 21. Dome type DODECA wooden frame for manual desalting



Hides (four workers) and skins (two workers) are beaten three times on the frame and the salt is collected manually from the floor. On average, it takes two hours to desalt one tonne of raw material.

It must be emphasised that all desalting measures mitigate the problem of salinity to a very limited extent and certainly are not a complete answer to this challenging issue.

Furthermore, although the salt from preservation from soaking is by far the largest source of the Total Dissolved Solids (TDS) load in effluents, it is not the only one: some contamination emanates from other stages of the conventional tanning process, such as delimiting, pickling, tanning and retanning.

8. HAIR-SAVE UNHAIRING, LIMING

8.1. Liming with hair-burn unhairing

As said earlier, the main aims of the liming process are:

- removal of hair (wool) and epidermis
- removal of any interfibrillary components remaining after soaking and “opening up” of the fibre structure, including an acceptable level of swelling
- partial saponification of the natural grease

The well-known stability/non-solubility of keratin and its resistance to chemical attacks is due to strong bisulphide cross linking (intermolecular or intramolecular) of cystine, the amino acid richly present in keratin’s structure. Some strong reducing agents such as traditionally used sodium sulphide – Na₂S and sodium hydrosulphide – NaHS are able to break down the bisulphide bond¹⁰:

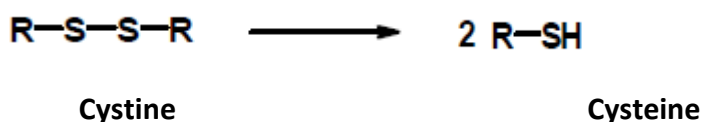

In the conventional liming – hair burning process, the liming chemicals either destroy the hair and epidermis completely or loosen them to such an extent that they can be removed mechanically without any difficulty. At the same time, they bring about a certain amount of swelling (plumping) of the fibre structure and partial saponification and emulsification of the hide fat. The liming is usually carried out with hydrated lime – Ca(OH)₂ and sodium sulphide – Na₂S and/or sodium hydrosulphide – NaHS, which has a less pronounced plumping effect.¹¹

In addition to high water consumption, soaking and liming with hair-burning are the most polluting part of the entire process of leather manufacturing in terms of nearly all key parameters (BOD, COD, Suspended Solids, TDS/salinity and nitrogen).

8.2. Hair-save unhairing

Hair-save unhairing of hides in pits or sweating skins has been used since time immemorial; hair-save lime-sulphide unhairing dates from the 1880’s and was widely practiced. Modern commercial methods were developed the advent of drums fitted to recirculate the liquor and separate the loosened hair. The main reasons for use of hair-save in modern times are:

- significant decrease of organic pollution load, including nitrogen
- significantly lower volume of sludge for reuse or disposal
- lower costs of effluent treatment (chemicals, energy)

¹⁰ Strong oxidative agents such as NaClO₂ or Na₂O₂ are also able to break this bond but for various operational limitations, including OSH aspects, oxidative unhairing has not been accepted by the industry.

¹¹ A few years ago it was suggested to consider using 1,4-dimercapto-butan-2,3-diol (DMB) as the reducing agent in the first step followed by a proteolytic enzyme in the second step of unhairing. It was claimed that lime was not needed and there was no risk of development of hydrogen sulphide. It seems that high costs prevented further development and large scale testing of this method.

The presently prevailing hair-save process utilises conventional chemicals normally used in the hair-burning system (lime and sulphide) but applies them in a somewhat different manner resulting in proven environmental benefits; enhanced leather properties are also likely whereas claims about improved area yields are not quite convincing.

The principle of the method is quite simple: the hair fibre is firstly partially immunized by an alkali (lime) to be subsequently removed by the action of sulphide and ultimately recovered by filtration.

First step: Removal of intact hair by manipulating the pace of adding lime and sulphide

Second step: Opening up of the fibre structure by conventional lime/sulphide process

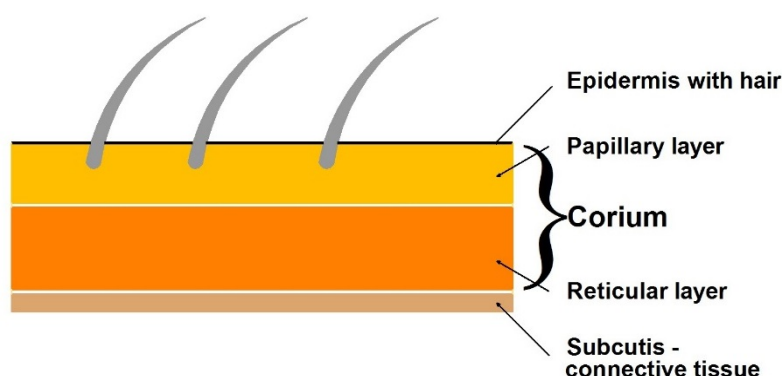

Figure 22. A schematic cross-section of bovine hide

This is possible because the fully developed keratin in hair, nails and the upper part of the epidermal layer is highly resistant to chemical or biological attack, except from sulphide which breaks down the disulphide bonds. The immature keratin found in hair roots, hair root sheaths, and the lower layer of the epidermis is more easily degraded and dissolved.

The resistance of keratin to chemical degradation can be substantially increased by immunisation i.e. treatment with an alkali, but without sulphide. The alkali transforms the sulphur cross-links into different, highly resistant thioether bonds. Mature keratin is much more easily immunised than immature keratin. This increases the difference in degradability between hair and hair roots, thus simplifying the hair-save unhairing process.

The point at which the hair breaks is decisive to the success of the process; the lower the breakage down the hair shaft in the follicle, the better the process. Any hair debris remaining in the follicle is a problem, especially with black-haired hides.

Immunisation can be achieved by using sodium hydroxide, lime or calcium hydroxide; it usually takes 1-1.5 hours. Most commercial systems for hair-save unhairing are based on immunisation.

A careful balance between insufficient immunisation and over-immunisation must be maintained. In the event of over-immunisation, the hair cannot be loosened satisfactorily in the subsequent unhairing stage. Obviously, the amount and use of a reducing agent, the amount of alkali as well as the time and temperature of immunisation are critical for the success of the process.

The hair is loosened by intensive mechanical action during the chemical unhairing process. This mechanical action entails a risk of abrasion, and hence damage to the grain. Suitable measures must be taken in order to prevent this (for example, by adding slip agents).

After loosening, the hair must be separated from the liquor as soon as possible in order to minimise the pollution load since prolonged immersion may to some degree dissolve the hair substance and reduce the filterability of the hair. Temperatures up to 30°C are considered safe, whereas at 35°C the hide substance is drastically damaged, especially in the grain layer. In tropical countries where fresh water temperatures may be higher than 30°C, it may be necessary to use paddles instead of drums for unhairing and/or adding ice to reduce heat induced by friction.

For reasons not fully understood it seems that the hair-save unhairing method works better on hides preserved by salting than on fresh hides; again, given the almost insurmountable environmental problems associated with salinity, this aspect should not impede switching to processing fresh/chilled hides wherever possible.

8.2.1. Painting

Painting is a traditional hair-save method for calf, sheep, hair-sheep and goat skins; also, it is obligatory where the hair/wool is valuable. Skins are painted by hand or on a machine on the flesh side with a paste consisting of sodium sulphide, lime or china clay or organic thickeners and water. Typically, to the solution containing about 10% sodium sulphide (9 °Bé) lime is added until about 15 °Bé; the final density of the paste of about 20 °Bé or more is achieved by adding kaolin (china clay).

Although very seldom, painting on the grain side is also used for special types of rawstock to produce a particularly smooth and fine grain; the hair is completely destroyed.

After painting, the skins are stacked in a pile, hair side against hair side. The unhairing chemicals penetrate the skin from the flesh side and destroy the hair roots. It is then a simple task to scud off the hair that is not in contact with the unhairing chemicals. Mechanical unhairing and re-liming are necessary; painting is labour intensive, requires more space and usually takes more time.

Figure 23. A pile of painted sheep skins



Thus, the basic recipe in summary is as follows¹²:

Immunisation:	Max. 150% water 28°C 1.5 % lime 45 minutes (15 min. rotation)
Unhairing:	+ 1.5 % sodium sulphide flake (60% Na ₂ S) After 1 ^{3/4} - 2 hours filtration until clear
Reliming:	+ water up to 180-200% 2% lime

Run at low speed (2-3 rpm) approximately 14 hours

In order to obtain a perfectly clean pelt grain, a minimal amount of enzyme is added to the reliming liquor. The advantage of the method is that proprietary products are not used and the chemical costs are comparatively low.

8.2.3. Sirolime system (CSIRO, Australia)

The main steps/stages are: Soak, grain penetration with “inactive” hair release agent, removal of the “inactive” hair release agent from hair surface, hair immunisation, activation of hair release agent (usually with OH⁻), hair removal by mechanical action and filtration.

Owing to its health hazards, i.e. use of Ca (ClO₃)²⁻ it has failed to spread, but it is reported that a modified Sirolime process has been used successfully for green hides in Australia.

8.2.4. Unhairing with organic sulphur compounds

Three types of organic sulphur compounds are used in proprietary products based unhairing systems:

- Mercaptoethanol
- Salts of mercaptoacetic acid (thioglycolic acid)
- Formamidinesulphinic acid

These compounds are strong reducing agents, acting in the same way as sulphides. The advantage of their use is that they considerably reduce the amount of sulphide consumed and discharged with the waste water; also, their oxidation results in harmless substances. On the other hand, these chemicals are much more expensive so they are mostly used in instances where effects other than environmental improvement are sought. For example, liming with these compounds yields a lower degree of swelling than using lime and sulphide only with possible positive effects on the area yield and the smoothness of the grain.

The use of mercapto products requires the application of occupational health standards and the same protective measures as the use of sulphides. Free mercaptanes in the air are actually more toxic than hydrogen sulphide, but for several reasons (such as higher oxidation rate during the process, lower tendency to generate free mercaptanes, and the latter's

¹² Generally, it is taken that the concentration/purity of lime – Ca (OH)₂ is 100%, Na₂S 60-62 % and NaHS 95 %. Lime is added as a suspension but very often directly from bags.

higher boiling point) the risk of mercaptane vapours being released into the atmosphere is considerably lower than is the case for hydrogen sulphide. Owing to their high oxidability, thio-compounds have to be thoroughly mixed when being added to the float. In any case, suppliers normally provide detailed guidelines for their use.

8.2.5. Enzymatic unhairing

Enzymatic processes are hard to control; commercial preparations containing proteolytic enzymes attack the collagen of the grain layer to a certain degree, too leading to looseness of grain and grain sueding. Moreover, enzymes alone cannot eliminate the ground and fine hair completely. Thus, it is unlikely that an unhairing process exclusively based on the use of enzymes will ever be practically possible. Also, enzyme preparations are expensive and in most cases the environmental benefits they offer are insufficient to justify the cost.

Enzymes, however, are extensively used to support alkaline immunisation-sulphide unhairing to eliminate ground and fine hair and to obtain cleaner pelts.

With the combination of the sulphide and an unhairing enzyme, the hair is broken in the zone just above the root- the pre-keratinous zone

- Enzymes are applied at low levels (e.g. 0.15 %)
- Enzymes target epidermis and interfibrillary matter but often grain enamel is also damaged
- Simultaneous reduction of lime (to cca 1.5 %) and of sulphide (to cca 1.0 %) is not essential but cannot be ignored
- Enzymes are rather expensive
- Good process control is essential

Finally, enzyme unhairing has been used on long-haired goatskins since the grain layer on goatskins is more resistant to enzymatic attack than that on skins or hides of other species.

8.3. Hair separation and float recirculation equipment

Modern hair-save unhairing processes require equipment for recirculating the float and separating the hair.

Hair separation is preferably carried out at the same time as hair loosening so as to minimise degradation of the hair. Modern drums are equipped with recirculation as well as temperature, and pH regulations are commercially available. The float is pumped out of the drum laboratory box and fed back in again through a hollow axle.

In older drums without a recirculation laboratory box, a recirculation and filtering system can be fitted provided that the drum axles can be used for float circulation.

For that purpose it is necessary to install perforated plastic or wooden elements inside the drum (on one or both sides, if the drum is big enough), drill holes of not less than 80 or 100 mm diameter on the external side and fix of a manual valve; again, depending on the drum size, semi-circular float collecting gutters are fitted on one or both sides of the drum (see pictures below).

Figure 25. A battery of drums with semi-circular float collection gutters



It is important that the filtering capacity is sufficient to maintain the appropriate recirculation speed and complete filtering process within the required time. The typical flow capacity of commercial recirculation-filtering systems is 600-1000 l/min.

Various types of sieves (e.g. wedge wire screen, vibrating wedge wire screens rotating drum sieve, mesh gauge is 0.5-1.0 mm) can be used to separate the hair; the float may be pumped to the sieve through the vessel's existing circulation pump or via separate pumps recovering up to 90% of the loosened hair. Nowadays most of the screening systems on the market are combined with dewatering devices.

Figure 26. Hair-save system with rotary drum filter and collecting pit

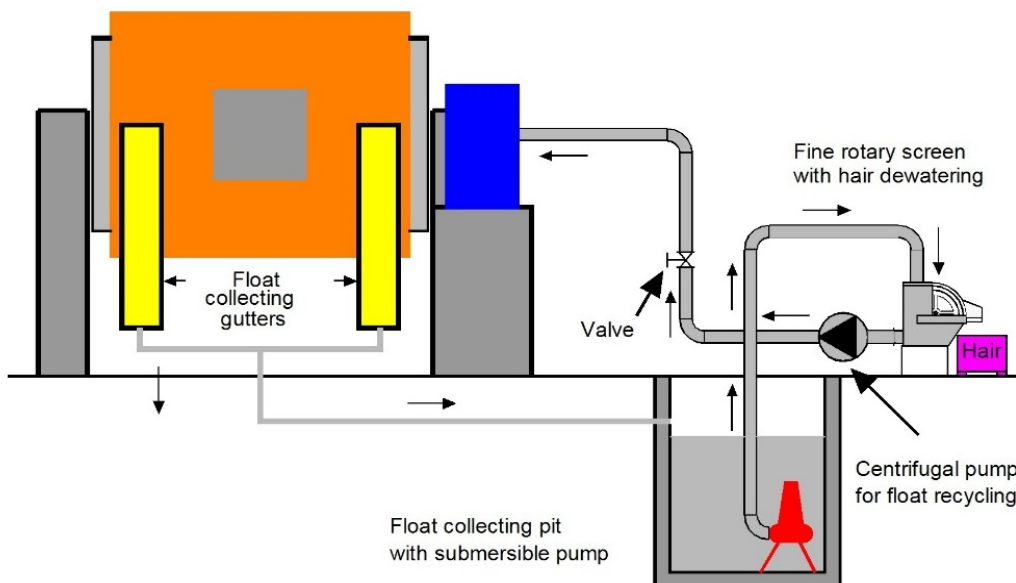

Chart by M. Bosnić

Figure 27. Hair-save set up, cross-section view

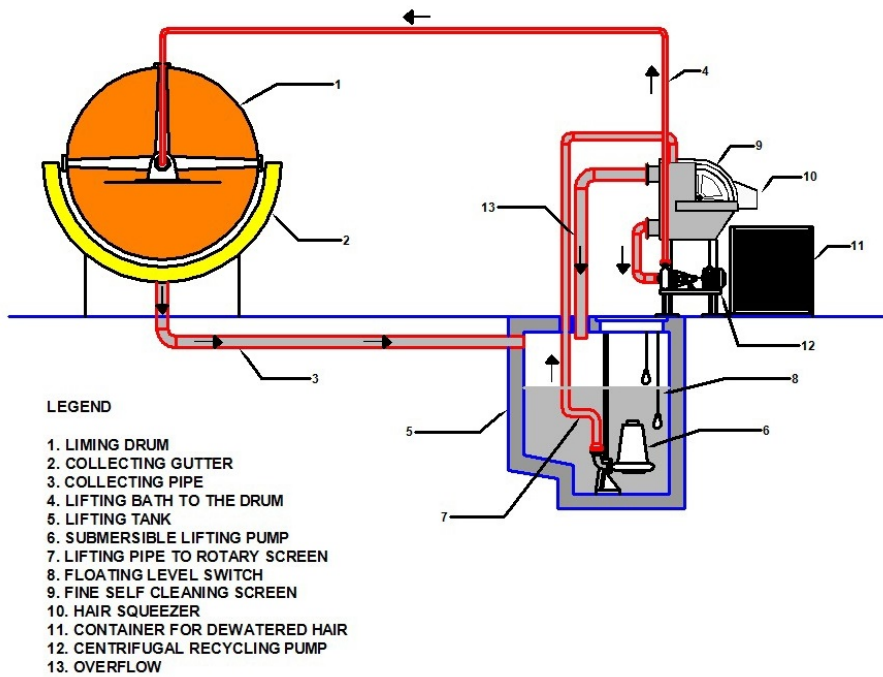

Chart by M. Bosnić

In the screw type press with compactor the hair separation takes place in the filtering pipe with a semi-circular section of the perforated plate with a screw scraping the inner surface; the hair is dewatered in the rubber cone section.

Figure 28. Screw type screen with compactor and container



Dewatering separated hair is not always easy, but it is important for further handling.

The cost of introducing hair-save unhairing depends on the host factors such as tannery size, the scope of retrofitting existing drums vs. purchase of modern drums with recirculation systems, availability of chemicals, etc.

However, meeting specific pollutants' discharge limits (primarily for nitrogen), may prevail over other considerations and induce the tannery to switch to hair-save. In any case, every cost-benefit analysis of hair-save unhairing has to consider the specific local conditions.

The claims about increased area yield do not appear sufficiently supported by reliable figures.

Generally, it is believed that the costs of chemicals for hair-dissolving and lime-sulphide hair-save are of the same magnitude; if the latter is enzyme-assisted, the cost is likely to be somewhat higher but worth the additional cost. As a rule, the costs of using specialty, proprietary hair-save systems are higher, sometimes substantially.

8.4. Prevention of H₂S emissions from effluents

Effluents from the unhairing and liming processes contain high concentrations of sulphur compounds derived from the sodium sulphide used in unhairing. If the pH of these effluents is allowed to fall below 9.5, hydrogen sulphide gas will evolve. These liquors may be oxidised (biologically or by adding chemicals using manganese sulphate as a catalyst) before being mixed with acid effluent or being discharged to the general mixing tank which generally has a pH of 8.5 – 9.

Sulphide-bearing effluents from the beamhouse are normally treated separately to reduce the sulphide levels in the waste water treatment plant, and to prevent the release of hydrogen sulphide when acidic effluents are mixed with effluents containing sulphide.

If sulphide-bearing effluents are to be mixed with acidic or neutral effluents before full oxidation of the sulphide is achieved, the mixing must be carried out in an enclosed tank, with air extraction through either a carbon filter or a scrubber dosed with either hydrogen peroxide or alkaline sodium hypochlorite.

Precautions to avoid the formation or emission of hydrogen sulphide are taken for some or all of the following reasons:

- to avoid toxic gas concentrations within the tannery;
- to prevent emissions of hydrogen sulphide as an air pollutant;
- to reduce odour nuisance, which can occur even in very low H₂S concentrations.

A quarter of the overall nitrogen releases stem from liming and unhairing

Low emissions of sulphides might even arise if no agents containing sulphide are used because some degradation products from keratin are alkyl sulphides.

Thiols, which are added or are formed by the degradation of sulphur containing proteins, are found in waste water effluents. Some are highly volatile, so they could cause an odour problem in the waste water treatment and may need abatement measures.

8.5. Oxidative unhairing

It is reported that oxidative unhairing is already implemented in Italy at the industrial scale: it uses hydrogen peroxide for oxidation and sodium hydroxide as the source of alkali and it is carried out in a propylene drum fitted with an internal water jacket for temperature control. It is claimed that the pelts are comparable to those from the traditional unhairing and liming process.

8.6. The scope for hair utilisation or disposal

Nowadays environmental and possible cost benefits prevail over the problem of coping with yet another solid by-product. The quantity of hair recovered in relation to the weight of raw hide varies considerably. Basically, it depends on hair length and hide thickness and, in turn, these properties are linked to animal breed, gender, age, season, etc. Typical ranges are given in the table below.

Table 11. The amount of hair in relation to hide/skin weight

	% drained hair	% hair dry matter
Heavy bovine hides	10-15*	3-5*
Light bovine hides	15-20*	5-7*
Calf skin	20-40**	10-13**
Sheep or goat skin	60-90**	20-30**

* Calculated on salted weight

** Calculated on dry weight

The dry matter content of the drained hair is approximately 33% whereas at the end of the process it is 15-20%. After dewatering to 35% dry matter, the hair does not give rise to any odour when deposited as waste.

To avoid rapid putrefaction of the proteinaceous matter in the float adhering to the hair and development of malodour, the hair must be dewatered as swiftly as possible; the sulphide content in fresh, wet hair is approximately 80-100 ppm. Sulphide, however, oxidises easily; within three to four hours the sulphide content is less than 10 ppm and after a day the sulphide completely disappears. For some uses, including agriculture, the hair has to be washed primarily to remove the residual salt (sodium) very harmful for the soil. Full stabilization is achieved by simple drying.

Numerous proposals for bovine hair utilization, often speculative or founded on the strength of laboratory scale tests have been advanced:

- Felt production (historical use)
- Agricultural fertiliser (orchards, market gardens, nurseries)
- Animal feedstuff (cannot be used as a sole protein, lacks lysine and methionine)
- Gasification – fuel source
- Biodegradable flowerpots
- Some limited use in cosmetics

A more recent concept is a growth of keratin degrading bacteria and use of microbial keratinase to accelerate hair degradation within the composting process, the optimum

reported to be at 50°C and pH 9.0. At the moment there are only two areas of wider applications for hair recovered from hair-saving processes:

- agricultural fertiliser & composting
- animal feedstuffs.

Currently, in both areas, applications of partially or fully hydrolysed hair prevail by far. Uses of non-hydrolysed bovine hair, mainly based on its fibrous properties (e.g. felting) are insignificant.

Several companies in different countries produce organic nitrogen fertiliser prepared from partially hydrolysed, pelleted hair. As a source of slow-releasing organic nitrogen, hair is a valuable soil conditioner usually marketed as a special product primarily for orchards, market gardens, nurseries and private gardens.

Composting, typically in windrows is another approach: the hair which is not degraded is useful because it endows the compost with a long-term effect.

Hair protein can be used in the production of animal feedstuffs. Owing to a deficit of two essential amino acids, lysine and methionine, it cannot be used as the sole protein component in the feed.

Waste hair has also been in specific market niches such as in the production of biologically degradable flower pots or anti-weed soil covering. To a limited extent, hair has also been used in the production of foaming agents for fire-extinguishers.

8.7. Impact on pollution load

A wealth of information is available on the environmental load and impact of hair-save unhairing, much of which is provided by the suppliers of commercial systems. The following table presents a considered evaluation of what can be achieved in practice:

Table 12. Pollution load: hair-save vs. hair pulping, decrease in %

	Discharge from hair-save unhairing* kg/tonne raw hide	% reduction compared to hair-pulping	
		In unhairing liquor*	In total tannery waste water
Total solids	60	30	8
Suspended solids	15	70	43
BOD₅	20	50	28
COD	50	50	28
Kjeldahl nitrogen	2.5	55	22
Ammonium nitrogen	0.2	25	2
Sulphide (S²⁻)	0.6-1.2	50-60**	50-60**

*Including waste water from washing

** The percentage reduction of the discharge is greater than the corresponding reduction of the dosage

The sulphide discharge indicated in the table corresponds to 15-30 mg/l in the total waste water (at a water consumption rate of 40 m³ per tonne raw hide). The discharge with the waste liquor varies greatly depending upon processing conditions; actual results are better or poorer than those cited in the table.

It is evident from the table that introducing hair-save unhairing is only a partial solution to waste water problems; seen in relation to the total tannery discharge, sulphide and suspended solids are the quantities most reduced and, to a lesser extent, BOD₅ and COD. Despite reducing the sulphide discharge, subsequent treatment is still essential. Under these circumstances, each tannery must decide for itself whether hair-save unhairing is a worthwhile proposition. In any case, if substantial improvements in the waste water discharge are to be achieved, hair-save unhairing must be accompanied by the use of cleaner technologies in all other stages of the processing.

Table 13. Overview of hair-save technologies

Advantages	Disadvantages
<ul style="list-style-type: none"> • Lower BOD,COD • Lower Nitrogen • Lower suspended solids • Cleaner grain • Can be cheaper in the long run 	<ul style="list-style-type: none"> • Hair disposal problem • It requires a fundamental change of the process • Short hair roots • Initially more costly, investment costs

8.8. Summary on hair-save unhairing

- ✓ Introducing hair-save unhairing is not necessarily an advantage for every tannery; each individual tannery must decide for itself whether it is worthwhile to introduce the method as the optimum solution depends on specific local conditions.
- ✓ The starting point in any consideration should be a cost-benefit analysis encompassing:
 - savings in overall effluent treatment costs, especially those related to treatment and disposal of sludge;
 - possible additional costs of the method selected;
 - necessity to attain pollutants discharge standards, especially nitrogen and TDS limits;
 - possible impact/improvements in leather quality;
 - favourable image/marketing effects (“eco-leather”, eco-labelling);
 - economic implications of hair disposal.
- ✓ In evaluating a method, occupational safety and health (OSH) aspects must also be taken into consideration.
- ✓ In the course of introducing hair-save unhairing, other processes in the tannery should, as far as possible, remain unchanged.
- ✓ Environmental authorities may set specific requirements. As far as possible, these should be known well in advance so as to have adequate time in which to implement the new method.

- ✓ Before any new technology is introduced, it is important to ascertain whether, in terms of environmental and occupational safety, it is equal to, better than or maybe inferior to the technology it is going to replace. If needed, information on product toxicity must be obtained from the supplier.
- ✓ When evaluating a new technology, factors not directly related to the tannery (e.g. production of chemicals) should also be taken into consideration ('life cycle thinking').
- ✓ As with all cleaner technologies, hair-save unhairing presents only a partial solution to a tannery's environmental problems. A tannery that produces nothing but finished leather is utopian; cleaner technologies will never make end-of-pipe treatment unnecessary.
- ✓ Hair-save unhairing must be seen as a partial, but important element in the general optimisation of the production, including environmental aspects and better housekeeping.
- ✓ Combining hair-save unhairing with partial recycling of lime float and use of second, final washing float for the first (dirty) soak is possibly the optimum approach from both the practical and environmental aspects.
- ✓ Sulphide elimination is rather easily achieved through an end-of-pipe treatment, usually by catalytic oxidation.
- ✓ Only about 22% of the total nitrogen content in waste water is eliminated by hair-save unhairing. If nitrogen is a key problem, the hair-save unhairing must be supplemented by deliming without ammonium salts (for example, using carbon dioxide).
- ✓ Nearly all methods on the market claim to improve leather quality and increase area yields. These claims, however, cannot be taken at face value; they have to be verified in industrial trials over several months.
- ✓ Float collection and filtration after chemical unhairing is in practice the easiest method to implement using existing equipment. It thus entails relatively low investment costs. Cheap and simple screens can be selected, yet this approach is not optimal in terms of hair quality and reducing the waste water load.
- ✓ At present, the most realistic possibilities for utilising the hair recovered seem to be as a soil additive or animal feed. Slow degrading hair protein is especially beneficial in soils in dry regions prone to desertification since it increases the humus content of the soil.

9. DELIMING AND BATING

Mechanical operations have a significant impact on the character and volume of polluting solid, liquid and air emissions. While technical details can be found in standard textbooks, here are only some illustrations and points relevant for reducing the pollution load.

9.1. Fleshing

The environmentally preferred green fleshing has been described in an earlier chapter. Here it is important to take note of water sprinkled to clean the transport rollers and the working area which also facilitate the transport of fleshings by the screw feeder; too often this water is overlooked in computations of total water consumption.

Figure 29. Hydraulic heavy duty fleshing machine for calves, butt and cattle hides

(A screw feeder for removal of fleshings, automatic opening of water jets)

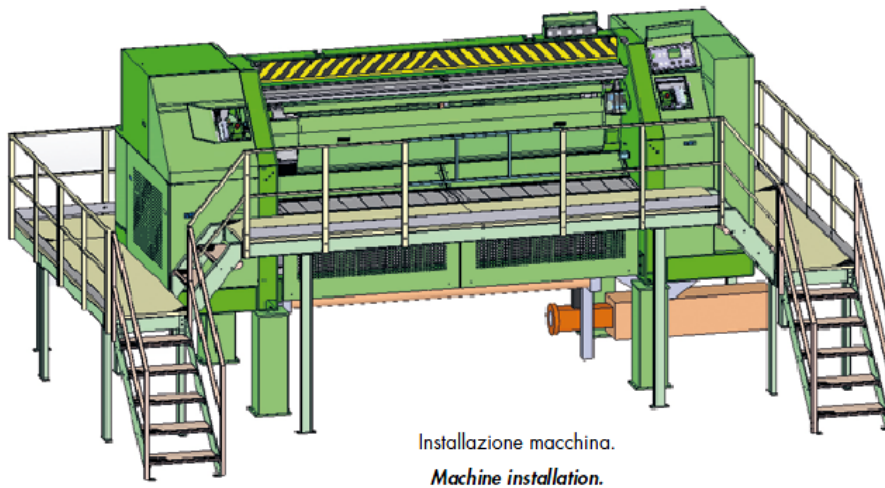

Source: Rizzi

9.2. Splitting

The machines used for lime splitting or tanned splitting are basically the same but there are differences in the hardness and roughness of the rollers. The splitting machine can be used for either lime splitting or splitting after tanning, but not for both operations at the same time.

Figure 30. Operating principle of splitting machine

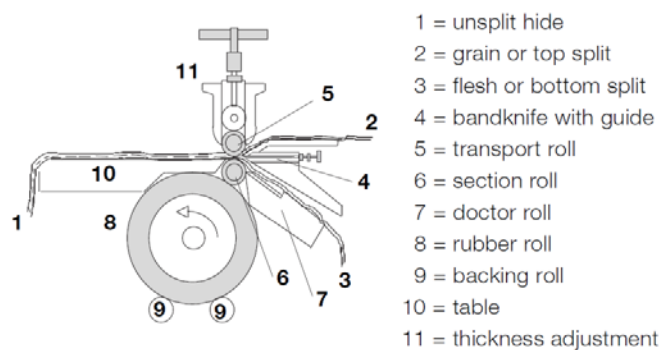

Source: BASF Handbook

A condensed overview of splitting in limed condition is given in the next table

Table 14. Overview of ex-lime splitting

Advantages	Disadvantages/Limitations
<ul style="list-style-type: none"> • Lower consumption of chemicals in subsequent processes • Shorter processing time due to lower pelt/leather thickness • Shorter processing time brings about lower energy consumption • Permits to use different tannages for grain and splits • More non-tanned vs. (chrome) tanned solid waste, wider range of utilization options • Facilitates environmentally preferred CO₂ deliming • Better area yield 	<ul style="list-style-type: none"> • Limed pelts are hard to handle • Handling of pelts with a pH of about 12 and with residual sulphide requires specific OSH measures • Lower accuracy in comparison with splitting of wet blue • Shaving of lime split leathers might be more demanding (especially of splits) • Splitting of thin hides may result in a loss of split yield • Generally it results in a somewhat higher amount of shavings

Hides for upholstery and automotive leathers are usually split in limed condition.

The ratios between splitting thickness and area and thickness in the wet blue stage shown in the table below can be considered quite representative.

Splitting	1,000 kg raw hides	Wet blue, area, m²	Wet blue, thickness, mm
2.2-2.4 mm	1,000 kg	116	1.6-2.0
2.8-3.0 mm	1,000 kg	108	2.0-2.4

Note: Chrome uptake/ chrome content in 2.0-2.4 wet blue is less by 0.1-0.2% compared to 1.6-2.0 mm wet blue

Figure 31. A splitting machine for both ex-lime and wet blue splitting



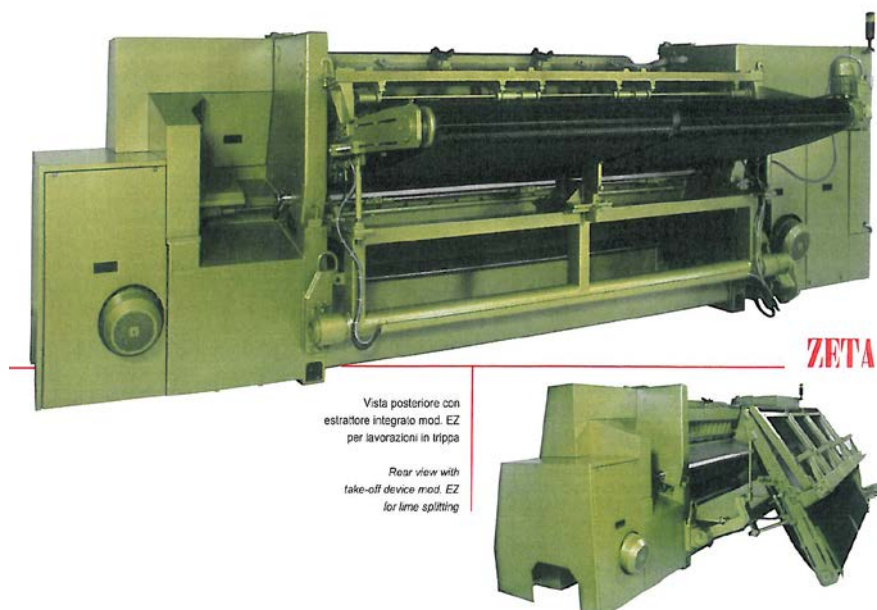

Source: Rizzi

9.3. Deliming

The aim of deliming:

- Removal of residual of chemicals used during unhairing and liming

Calcium salts have to be removed to avoid formation of insoluble and damaging salts during later stages, primarily of calcium sulphate, CaSO_4 ; also, removal of sulphide should prevent the formation of hydrogen sulphide as the pH drops.

- Reduction in pH in preparation for further processing

To lower the pH of the pelt from about 12.5 to a pH suitable activity of bating enzymes used for bating (35°C). Reduction of pH also brings about reduction in swelling.

To reduce the alkalinity and remove the calcium from the limed hides, a combination of washes and delimiting agents is used.

While chemicals such as ammonium sulphate, ammonium chloride, hydrochloric acid, formic acid, sodium bisulphite or metabisulphite are traditionally listed as suitable for this purpose, in practice it is largely ammonium sulphate.

Mineral acids are cheap, but it is hard to control the pH. There is a high risk of pelt damage because it is difficult to ensure uniform dosing and distribution. With organic acids there is no ammonia, they are relatively safe but again it is hard to control the pH and the penetration can be slow.

Ammonium sulphate is widely available, inexpensive and it has excellent buffering at pH for typical bating enzymes. However, despite such properties replacements have been sought

due to not only OSH considerations (harmful ammonia gas develops at the initial stage of deliming) but above all for significant contribution to nitrogen and TDS load in effluents. Reacting with lime ammonium sulphate forms calcium sulphate $\text{Ca}(\text{SO}_4)_2$ which, if the float is not too short, remains in the solution.

The amount normally added is about 2 – 3% on the wet salted weight.

9.3.1. Polluting emissions

- Residual sulphides from liming can, if the pH falls below 9.0-9.5 result in highly toxic, free hydrogen sulphide gas and this is the case in CO_2 deliming (and in pickling).
- Ammonium salts used for deliming in alkaline float produce harmful, malodorous ammonia gas.
- In practice, possibly the main issue is the large contribution of ammonium salts to the overall ammonia nitrogen ($\text{NH}_4\text{-N}$) load in tannery effluents. Furthermore, the content of nitrogen exceeding the desirable TOC: TN: TP ratio of 10:1:0.2 reduces the efficiency of the activated sludge treatment. Very often, despite adding carbon and phosphorus nutrients and despite extensive nitrification/denitrification steps, it is very hard to meet nitrogen discharge limits without eliminating or reducing the amount of ammonium salts in deliming.

Figure 32. Relationship between pH and release of H_2S gas

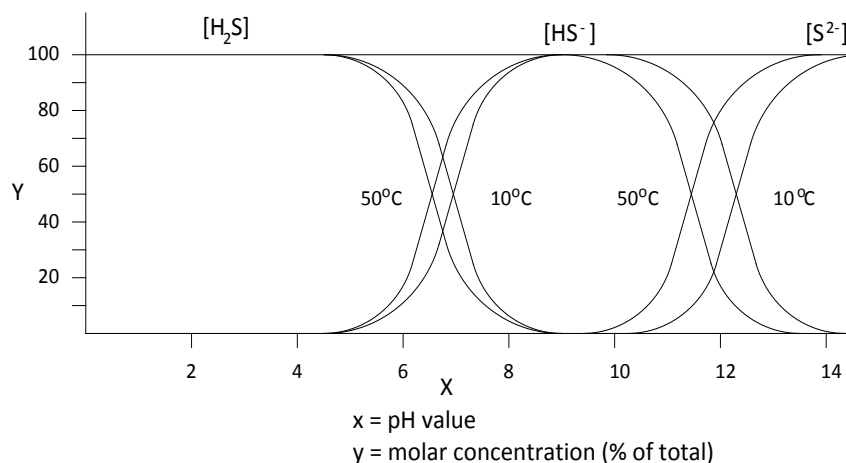

Chart by M. Bosnić, derived from BASF Handbook

Table 15. Discharge of ammoniacal nitrogen during deliming

Deliming agent	Discharge of ammoniacal nitrogen per unit of raw hide (kg/t)
2 % ammonium sulphate	4.5
1 % carbon dioxide + some ammonium sulphate	1.1 – 1.2
1 – 1.5 % carbon dioxide	0.02

9.4. Cleaner technologies options

9.4.1. Replacing ammonium salts with weak organic acids

Lactic acid, formic acid and acetic acids, esters of organic acids, magnesium lactate, non-swelling aromatic acids, etc. can be used to substitute ammonium compounds in the delimiting process. With the float of 200% they are added at the level of about 1.5% on pelt weight with a duration of about 1 – 1.5 hours. It is also believed that less agent is needed for the subsequent bating process.

However, replacement of ammonium salts with weak organic acids is not quite satisfactory because:

- While the $\text{NH}_4\text{-N}$ load is significantly decreased, there is an increase of COD load in the effluent
- There is no buffering effect comparable to that of ammonium sulphate
- The use of commercial products is several times more expensive than delimiting with ammonium salts.

9.4.2. Delimiting with carbon dioxide gas (CO_2)

As in nature, carbon dioxide dissolves readily in water and the weak organic acid (carbonic acid) formed has a high affinity to lime reducing the pH of the float and hides. The reaction between lime and carbon dioxide produces a water-soluble salt, calcium bicarbonate, $\text{Ca}(\text{HCO}_3)_2$.

There are different, rather simple techniques to introduce the CO_2 . Ideally, it is introduced into the drum recirculation system but it can also be injected into the float directly and even into headspace: since CO_2 is heavier than air, it settles onto the float surface. The process control is not very sophisticated. Obviously, there is no release of ammonium gas or to a limited extent only.

Carbon dioxide is usually supplied in cylinders; installation of a pressurised storage tank for CO_2 , diffusers and a warming chamber may be necessary. The consumption is of the order of 0.75 – 1.5% on the pelt weight. Some degreasing effect action as well as improvement in dye bonding at the later stages are also claimed. The leather quality is not affected. The cost depends on local availability – carbon dioxide distribution and prices; in Europe it is comparable to delimiting with ammonium salts.

However, there are some differences in the delimiting process:

- The final pH at the end of the process can be somewhat lower (pH 6.7 – 6.9) against pH 8.8 – 9.2 with ammonium salts; yet, with careful control it can be adjusted to the same range
- Some adjustments of the bating process might be needed
- The time needed for delimiting is longer

With CO_2 as a delimiting agent there is a substantial decrease of ammonium nitrogen ($\text{NH}_4\text{-N}$) but also of the total, Kjeldahl nitrogen (TKN) pollution load in effluents.

Table 16. Emissions in waste water from delimiting and bating

Emissions to waste water kg/tonne of raw hide	Ammonium salts	CO ₂
BOD	3	3
COD	6	6
TS	45	30
TKN	5	1.5
NH ₄ -N	4.1	01.-0.2

Source: EU BREF 2013

Limitations and undesirable effects:

- In some cases, especially with thicker, unsplit hides (more than 1.5 mm) delimiting with CO₂ has to be supported with reduced quantities of ammonium salts or organic acids or esters.
- If the final pH of delimiting is lower than the pH after ammonium delimiting, hydrogen sulphide, H₂S well known for its malodour and high toxicity can be generated and released. This can be prevented by the addition of 0.1 – 0.2% of hydrogen peroxide, H₂O₂ which in turn can be corrosive to wooden drums. It is claimed that some advanced dosing systems can eliminate this problem. In any case, a good ventilation system and treatment of extracted H₂S should be in place.
- Should the pH fall below 7, there might be some residues of melanin in the grain layer so that black and red hides may appear dirty.

While evaluating the costs of ammonium salts-free delimiting, substantial savings in the waste water treatment costs - mainly in nitrification/denitrification - have to be taken into account.

Table 17. Overview of carbon dioxide, CO₂ delimiting

Advantages	Disadvantages
<ul style="list-style-type: none"> • No ammonia gas or discharge to effluent • About 50% lower BOD • Good penetration on light skins • No risk of acid shock • No risk of lime blast • Automated, easy to use • Limited changes 	<ul style="list-style-type: none"> • pH too low for conventional bating enzymes • Suitable only for skins, light and/or split hides, not for heavy, thick hides • Use of hydrogen peroxide needed for hydrogen sulphide <i>in situ</i> removal • It requires cylinder hire • Longer delimiting times may needed

9.5. OSH at deliming

Due to ammonia gas and hydrogen sulphide gas associated risks, appropriate protection measures (prevention, neutralization, ventilation, etc.), including proper staff training have to be in place. Fixed and portable meters with coloured indicator tubes are a must.

Table 18. Overview of various deliming systems, summary

Deliming system	Advantages	Disadvantages
Ammonium salts	Cheap Buffers at pH for typical enzymes Easy to use, low(er) BOD	Very poor environmental performance (harmful gas, TDS, Nitrogen)
Carbon dioxide	No risk of acid shock and lime blast No ammonia, relatively safe	Not suitable for heavy, thick hides Use of hydrogen peroxide needed for hydrogen sulphide <i>in situ</i> removal
Organic acids	No ammonia, cheap	Close pH control, can be too slow
Mineral acids	No ammonia, cheap	Close pH control, damage risk

9.6. Bating

The purpose of bating:

To remove all residual and partially degraded proteins and interfibrillary matter from the pelt leaving it clean and open for pickling and the tanning process. This is done by using specific, commercially produced enzymes.

Enzymes are biological catalysts, usually but not always highly specialized for a certain type of substrate. It could be said that they work on a “lock & key” principle. Those that act on proteins in pelts during bating are called proteases and are of pancreatic (mainly) or of bacterial origin. Commercial bating agents are often mixtures of a few enzymes. They contain only 1 – 5% of active ingredients, the rest being inert carriers (wood flour, kaolin) and salts (ammonium chloride in most cases) as buffering and deliming agents.

As biological catalysts, active enzymes work best under their optimal temperature and pH conditions; for example, fungal enzymes work better under acidic and neutral (and thus within a wider range), bacterial enzymes work better under neutral or slightly alkaline conditions whereas for the optimum effect, pancreas based proteases need pH 8-8.5. Bating agents for tanneries are mostly tuned to work at pH 7-8 and at a temperature of 35⁰C.

Again, enzymes being basically proteins, irreversibly denature and are effectively destroyed at a temperature of about 70°C.

In addition to factors mentioned earlier, crucial for the impact is the enzyme activity value (Loehlein-Volhard Unit, LVU) expressed as the number of enzyme units in 1 g of bating agent where one enzyme unit has the capacity to digest 1.725 mg of casein.

In practice, the rating of bating agents is from 500-1000 LVU (weak, for technical and harness leather), 1000-1500 LVU (medium strong, for most types of leather) and 1500-2000 LVU (strong, glove and clothing leather). For dosing, normally 0.5 – 2.5%, concentration in the float is actually more important than the amount of enzyme calculated on the weight of hides.

Potential inhibitors of bating enzymes activities can be inhibited by biocides, surfactants, salt and excess deliming salts.

Thumb print and blow test are a tanner's traditional tools for the evaluation of the bating effect.

The environmental impact of bating is not significant. However, in addition to BOD and COD in effluent, there can be emissions of hydrogen sulphide and ammonium gas from residues from the deliming process and TDS load from non-active components of the commercial bating agent.

10. OPERATIONS IN THE TANYARD

10.1. General

Tanning is a process that transforms hides and skins into usable material, leather. Depending on the tanning chemical(s) used that bind to collagen, leather has excellent or at least better resistance to microbiological degradation and heat, better keeps the shape and dries easily.

Table 19. Overview of the main tanning systems

Type of tannage	Tanning agent used	Auxiliaries used
Chrome tannage	Basic sulphate complex of trivalent chromium	Salt, basifying agents (magnesium oxide, sodium carbonate or sodium bicarbonate), fungicides, masking agents (e.g. formic acid, sodium diphtalate, oxalic acid, sodium sulphite), fatliquors, synthans, resins
Other mineral tannages	Aluminium, zirconium and titanium salts	Masking agents ⁽¹⁾ , basifying agents, fatliquors, salts, synthans, resins etc.
Vegetable tannage	Polyphenolic compounds leached from vegetable material (e.g. quebracho, mimosa, oak)	Pretanning agents, bleaching and sequestering agents, fatliquors, formic acid, synthans, resins etc.
Synthetic tannage (resin-synthans)	Sulphonated products of phenol, cresol, naphthalene, cresylics, polyacrylates, melamine resins etc.	Fixing agents, either acid or alkali, fatliquors
Aldehyde tannage	Glutaraldehyde and modified aldehydes	Alkali, bleaching agents, tanning agent carrier
Oil tannage	Cod oil and marine oils	Catalysts such as manganese, copper or Chromium. Sodium bicarbonate or other alkali, aldehydes, emulsifiers

⁽¹⁾ The auxiliary used varies depending on the mineral used and the type of cross-link with collagen

Source: BREF 2013

Tanning with basified chrome salts presently utilized in 80-90% of leather produced worldwide is very fast and reproducible; it lends flexibility, high tensile and tear strength, good heat resistance, good vapour and air permeability, dyeing properties and general versatility that cannot be matched by any other tanning agent.

10.2. The main features of the chrome tanning process¹³

10.2.1. Pickling, tanning, basification

The standard chrome tanning process is constituted by three stages: pickling, tanning and basification which were considered and carried out separately whereas nowadays they more often overlap than not. Sammying, draining and, later on, operations in wet-finishing are also important for the overall chrome management.

¹³ For more detailed review of the process and computations of chrome balance see UNIDO papers *Chrome balance in leather processing and Chrome management in the tanyard*

Pickling is the preparation of pelt for tanning itself by acidification in saline solution. Under standard conditions this is achieved by the combination of sulphuric and formic acid (1.0 - 1.8%) or of sulphuric acid and sodium formate and not less than 5% in practice 6-7% on pelt weight of sodium chloride, NaCl to prevent acid swelling of the collagen¹⁴. If deliming is not quite complete, some hydrogen sulphide gas may be released into the air. Adding hydrogen peroxide or sodium metabisulphite to the float can prevent these emissions.

Factors to consider are the type of acid and its penetration, the choice of (neutral) salt and its concentration, the float and hide's cross-section pH and temperature.

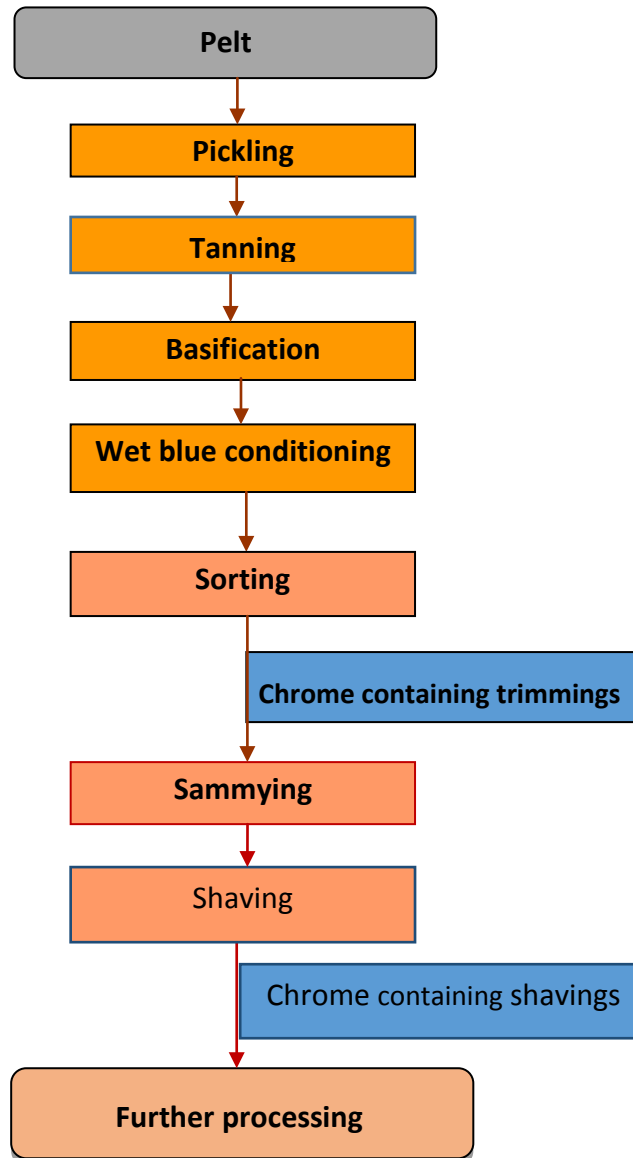

Figure 33. Flow chart of the main steps in the tanyard

¹⁴ It should not be overlooked that NaCl has a hydrotropic effect on pelts especially below the iso-electric point (pH 5.5) and that makes the hides softer; also, its hygroscopic effect helps to keep the moisture level under control (e.g. in wet blue leather).

For example, lower pH supports chrome penetration and even distribution whereas the type and salt concentration influence the swelling control; incidentally, higher concentration of chlorides in pickle contributes to the opening of fibers and softer skin better than sulphates.

In the case of skins to be stored and/or transported for a longer time, about 0.2% of commercial fungicides such as TCMBT or p-chlorometacresol are also added. Short float, 40 – 60% float is used; the time needed to bring the pH to 2.8 - 3.0 is about 1-2 hours.

10.2.2. Recycling of pickle floats

Most commercial chrome tanning products are supplied and used in powder form; they contain about 25% Cr₂O₃ of 33% basicity, the chrome offer in the conventional process usually 8-12% of the chrome salt corresponding to about 2.0 - 3.0% Cr₂O₃ on pelt weight. Under standard conditions, 60 - 80% float is used. Some surfactant auxiliaries may be added to improve the dispersion and penetration.

Basification, gradually raising chrome basicity from 33% to 66% increases the reactivity of chrome complexes and neutralises pickling acids. The commonly used basification agent is sodium hydrogen carbonate, NaHCO₃ in the amount of 0.8 - 1.2% on pelt weight added in several portions until the final pH 3.8 - 4.2 in the float is reached. Due to its low solubility and reactivity some tanners prefer magnesium oxide, MgO as a self-basifying agent, dosage being 0.6 - 0.8%; alternatively, they use chrome tannins containing a self-basifying component so that there is no need to add the basification agent separately. The temperature at the end of tanning and basification operations lasting at least 6 - 8 hours should be 35 - 40°C. After drumming, the leather is unloaded, drained and sammed.

The conventional chrome tanning is a rather simple, low risk process; deficiencies such as poor penetration and fixation, inadequate shrinkage temperature, and stains are easily avoidable.

Table 20. The main controls of chrome tanning	
Process conditions	Float length, Cr concentration, pH, temperature, time, mechanical action
Process control checks	Liquor density (Baumé) and pH, pH of the hide, Cr penetration, temperature (especially during basification), chrome content and shrinkage temperature
Common problems	Inadequate Cr penetration, poor fixation, shrinkage temperature too low, raw streaks
Post tanning aspects	Use of fatliquors and fungicides, ageing, sammying

10.2.3. Emissions

The main focus is on waste chrome which is contained in:

- Liquid waste: Spent floats from tanning and re-tanning, wet finishing (leaching!) as well as waste from sammying and draining.
- Sludge: Dewatered slurry resulting from sedimentation of suspended solids during primary (physico-chemical) effluent treatment.
- Tanned (solid) waste: Shavings, buffing dust and unusable (mostly wet blue) split, as well as crust and finished leather trimmings.
- Other: A mixture of salts, natural grease, traces of fungicides, residues of auxiliary agents

Figure 34. The share of the tanning department in total emissions

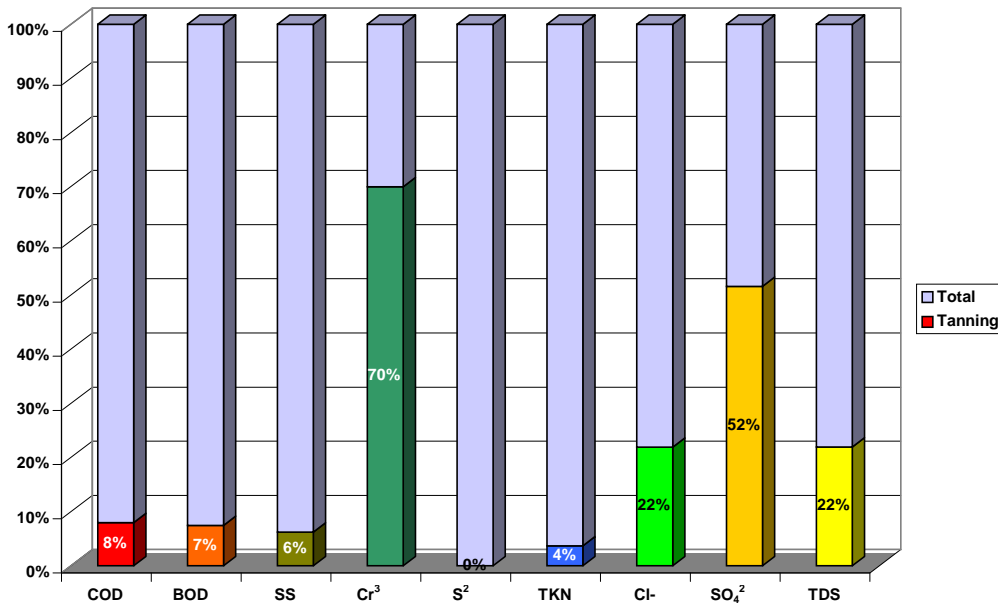
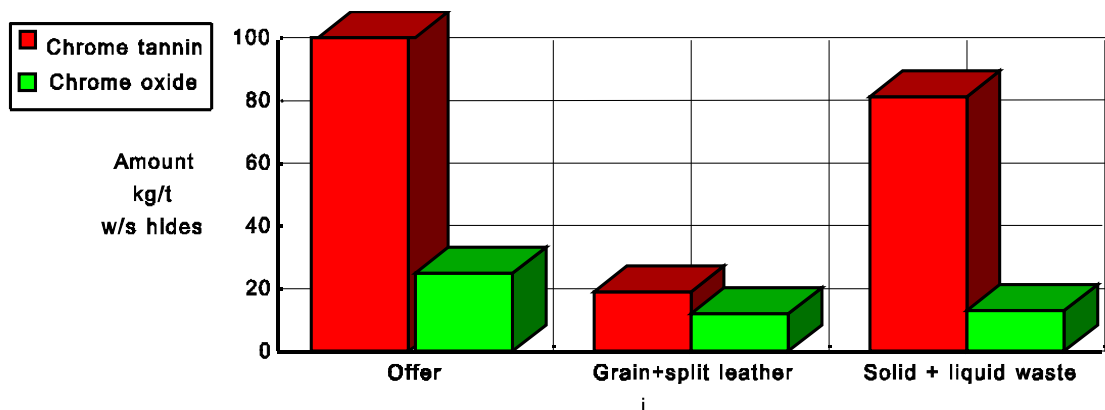

Chart by M. Bosnić

Limits on total chrome discharge in effluent vary widely between 0.05 and 10 mg/l for discharges into water bodies (direct discharge) and 1-50 mg/l on discharges into sewage systems (indirect discharge), the prevailing limit being 2 mg/l. Due to strict environmental regulations, disposal of chrome containing solid wastes in some countries may pose a significant disposal problem.

Figure 35. Chrome balance in leather manufacturing



Source: Mass balance, J. Buljan, UNIDO

The balance is based on a general application of chrome tannin containing 25% Cr_2O_3 and neutral salts. It is calculated for the use of: (a) 2% Cr_2O_3 on pelt weight for tanning; and (b) 1.2% Cr_2O_3 on shaved weight for re-tanning. In these models, it is also assumed that chrome reacts with pelt collagen in the form of basic chrome sulphate.

One example of the amount of chrome discharged in effluent from individual operations under standard technological conditions is shown in the next table.

Table 21. Chrome discharged in effluent from individual operations

Operation	Cr_2O_3 kg/t w.s. hides
Offer	21
Discharge	
Spent tanning float	4.1
Sammying and draining floats	1.5
Post-tanning floats	1.3
Washing float after post-tanning	0.2
Total discharge	7.1
Utilization %	66

In general, chrome uptake under typical technological conditions is 60 - 80% of the offer. The share of chrome oxide discharged in effluent from individual operations is illustrated in the next Figure.

Figure 36. Share of Cr_2O_3 discharged in effluent from individual operations under standard technological conditions in %

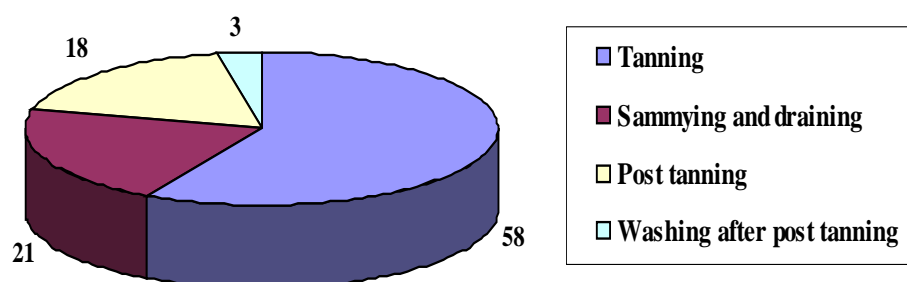

While the main portion of the chrome in effluent comes from the tanning float, significant amounts are discharged from sammying and re-tanning. Thus, chrome management has to consider all operations in the tanyard and the wet finishing department; maximising chrome uptake should be the first priority in any chrome management improvement project.

Figure 37. Shaving machine with cross-section schematic view



Source: Rizzi

10.3. Better chrome tanning

10.3.1. Pickling

The main goal is to significantly reduce or entirely avoid the salt (sodium chloride) used to prevent acid swelling and thus reduce the overall Total Dissolved Solids (TDS) load of tannery effluents having such a negative impact on ultimate water recipients.

Various low- and salt-free pickling systems have been proposed and tested such as use of non-swelling polymeric sulphonic acids, partial substitution of chloride by using e.g. aromatic sulphonic acids, etc. but to date they have not been widely accepted by the industry. It seems that the main reasons for this are neither higher costs nor higher COD but their perceived impact on chrome tanning and dyeing and ultimately leather characteristics. Thus, recycling of pickling floats in combination with recycling of tanning floats for the time being remains the best option.

10.3.2. Tanning

To improve the efficiency of the chrome tanning process, it is essential to increase the chrome uptake and thus reduce the chrome concentration and the total amount of chrome in residual, spent floats. In principle there are two basic approaches to achieve this goal, both of them with certain variations and advantages and limitations:

- Optimisation of the parameters of the conventional process
- Modifying the tanning process (conventionally called high exhaustion systems)

A combination of the optimisation of process parameters and modifications of the tanning process constitutes the basis for a modern, environment friendly high-exhaustion chrome tanning process, but for better understanding they will (firstly) be reviewed separately. Obviously, the lower chrome input also results in lower discharge of dissolved solids (TDS) in mixed effluent.

10.3.2.1. Optimisation of the parameters of the conventional process

Here a tanner significantly improves the chromium uptake without introducing any new chemicals. The main parameters that affect process efficiency and should be optimised are:

- mechanical action
- offer and concentration of the chrome tanning agent

- pH
- temperature
- reaction time

Thorough liming also contributes to better chrome uptake whereas splitting after liming improves the chrome penetration and reduces the consumption of chemicals.

Mechanical action

Drum dimensions and rotation speed are essential to ensure intensive agitation required to achieve good chrome penetration and completion of the tanning process within a reasonable/desirable time. At the same time, as with pickling, drum motors and transmission systems must be able to cope with very short floats.

Offer and concentration of the chrome tanning agent

Evidently, the higher the chrome concentration in the float, the faster the chrome penetration is into the fibre structure and the faster the reaction between collagen and chrome. For safety and quality, tanners traditionally tended to use more chrome powder than theoretically needed; this attitude is in direct conflict with the need to improve the exhaustion rate (better with the lower chrome offer).

With an offer of about 2% Cr₂O₃, a shrinkage temperature of 110°C can be achieved but the efficiency – exhaustion rate is only 65%. For a shrinkage temperature of 100°C, an offer of only about 1% Cr₂O₃ suffices and the efficiency is even up to 80%. However, not to risk inadequate boil fastness and an uneven cross-sectional distribution, a chrome offer of less than 1.7% Cr₂O₃ is not practiced.

Leather tanned with an offer of about 2% Cr₂O₃ contains 4 - 5% Cr₂O₃. In practice, a chrome content of about 3.5% Cr₂O₃ is needed in order to achieve a shrinkage temperature of 100°C.

Reaction time, pH and temperature

Under constant conditions, the longer the tanning time, the higher the chrome content in leather while shrinkage temperature increases. Better chrome uptake, increased chrome content in leather and higher shrinkage temperature can also be achieved using a higher pH because it results in higher astringency of chrome complex species.

Increasing either the temperature or the pH of chrome tannage increases chrome fixation and the higher chrome content raises the shrinkage temperature. However, it should be remembered that the temperature increase primarily governs chrome fixation, whereas a pH increase primarily governs the rise in shrinkage temperature.

The relationship between chrome uptake and shrinkage temperature also depends on the pace of temperature and pH rise during tannage:

- The earlier the heating is started, the higher the chrome uptake; however the initial temperature must be below 30°C.
- The heating pace has little or no effect on the shrinkage temperature.
- The pace of basification has little or no effect on the chrome uptake.

- Early basification is likely to yield a lower shrinkage temperature, but late basification will have neither a positive nor a negative effect on shrinkage temperature.
- Slow, regular increments in pH during basification result in the maximum shrinkage temperature.

Furthermore,

- Better chrome uptake and reduced chrome concentration in effluent can be achieved by finishing the tanning at the highest possible pH and temperature. End values of up to 40 - 45°C (even 50°C has been reported!) and pH 4.0 - 4.2 are advantageous.
- It is recommendable to use a low chrome offer combined with high chrome concentration in the float and extend the tanning time as far as possible at high(er) drum speeds. A chrome offer lower than 1.7 % Cr₂O₃ is not recommended for commercial applications.

In any case, efficient tanning, without imparting leather quality, requires the skill of balancing, i.e. supporting the reaction between the chrome complex and collagen and avoiding chrome precipitation.

Figure 38. Effect of the final pH and temperature (°C) on tanning efficiency in % of chrome offer fixed on collagen

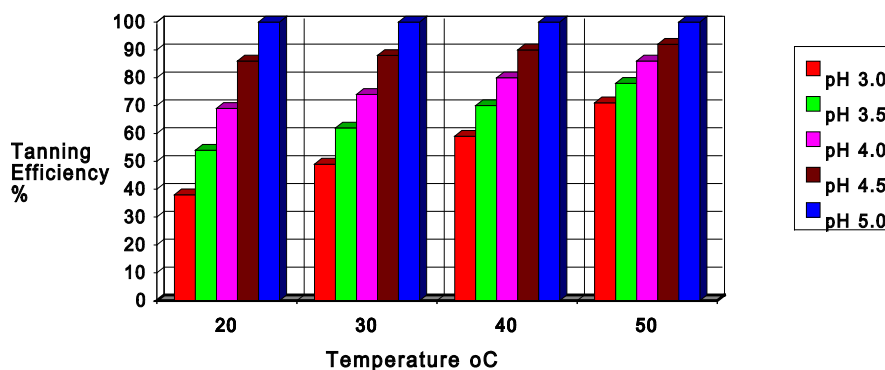

Figure 39. Parameters to be optimised in the chrome tanning process

Reduce	Increase
Chrome offer The pace of pH change and changes The pace of temperature change	Mechanical action Temperature pH Reaction time

10.3.2.2. High exhaustion - Modification of the tanning process

Here again, to improve chrome uptake and reduce chrome concentration in effluent there are basically two approaches:

- Masking of the chrome tanning complex
- Increasing the collagen reactivity

Chrome utilisation in a high-exhaustion tanning process goes up to 98%, a dramatic increase in comparison with conventional tanning (about 65%). As a (very desirable) corollary there is also a significantly lower level of chrome concentration in residual floats; also, in a high-exhaustion tanning procedure, chrome leaching at later stages is minimal. Leathers from both conventional tanning with a chrome offer of 1.9% Cr₂O₃ and high-exhaustion tanning with a chrome offer of 1.3 % Cr₂O₃ contain approximately the same amount of chrome - in the range of 4.0 - 4.5 % Cr₂O₃.

Masking of the chrome tanning complex

Masking is the incorporation of certain reactive groups (ligands) into chrome tannin complexes with the aim to reduce their affinity to collagen and enhance the chrome penetration rate to permit basification to a higher pH value without risking precipitation of chrome complexes. It also gives a smoother grain.

There is a wide range of readily usable masking tanning auxiliaries available on the market. They can be of rather different nature: formate, acetate, oxalate, dicarboxylic acids (short- and long-chain), aliphatic dicarboxylates, low molecular weight polyacrylates and syntans, etc. each of them with specific properties and performances. They may be applied at the start of the tanning process or even form a part of the basification system. The amount of the masking agent can vary from 0.5 to 1.0%.

Excessive masking has some negative effects such as slower polymerisation of chrome complexes and too low affinity and bonding to collagen. Too high a temperature may result in uneven and drawn grain.

More recently (e.g. BREF 2013) it has been reported that strong masking makes chrome precipitation difficult and that if an aromatic dicarboxylic acid like phthalic acid is used, complete precipitation is not possible and there are doubts about whether high exhaustion based on such masking agents can be considered a cleaner method at all.

Increasing collagen reactivity

Higher collagen reactivity is usually achieved by increasing the number of carboxyl groups on the amino acid side chains of the collagen so as to provide more sites for crosslinking. Glyoxylic acid and commercially available tanning auxiliaries based on glyoxylic acid are being used. Dosing to the pickling float is often practiced.

Fixing the chrome with special polymer acrylate, chrome concentration in residual floats is around 10 mg/l while it ranges between 200 - 500 mg/l when a conventional post-tanning procedure is applied; the chrome discharge from post-tanning operations in effluent is reduced to less than 0.4 kg Cr/t w/s hide.

Figure 40. Comparison of chrome distribution

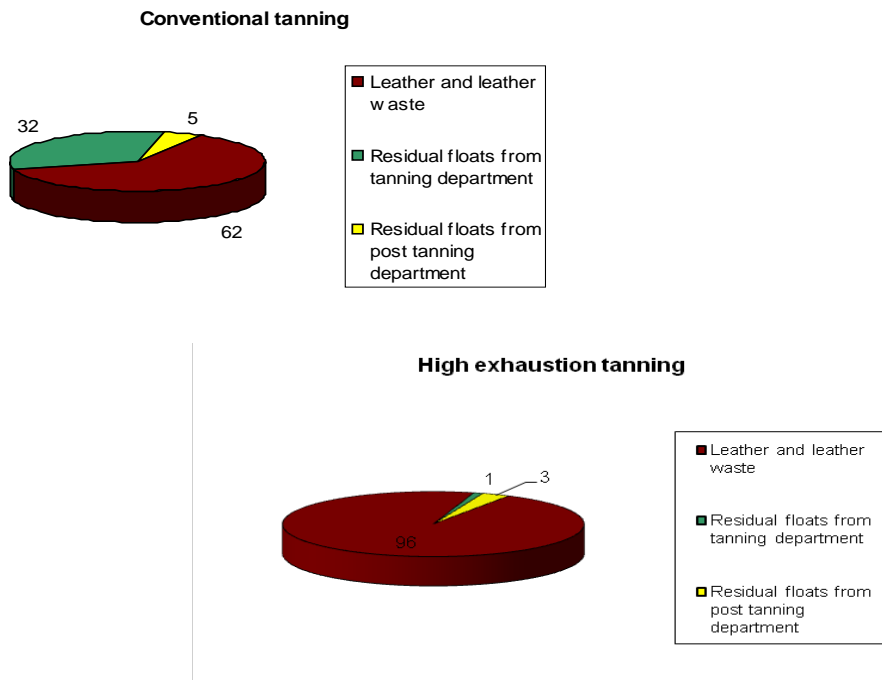

With high exhaustion the discharge is only 4% of the chrome offer i.e. nearly one tenth of that in conventional tanning. Ultimately, the chrome offer can be reduced by 35% and the amount of residual chrome of only 0.4 kg Cr/t w.s. hide or only 13 mg/l in mixed waste water streams at the water consumption level of 30 m³/t w.s. hide.

10.3.2.3. Direct chrome recycling

Recycling spent floats direct from chrome tanning back into processing is the simplest means of reusing chrome. There are many, many variations of recycling practiced to suit local conditions such as space/infrastructure available, type and quality of leather produced, costs of chemicals, labour and, in particular, chrome discharge limits. Here are some examples:

Recycling of spent tanning float to pickling

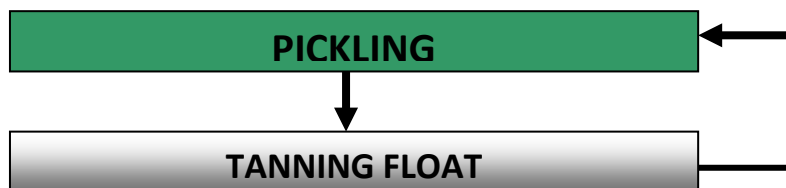

Separate recycling of spent pickling and tanning floats

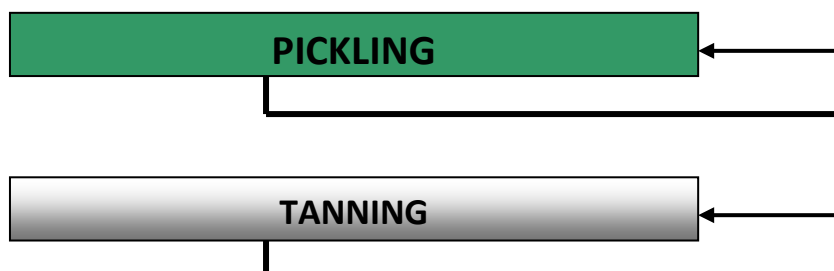

Another option: Spent tanning float plus draining water is recycled in the following tanning run. Waste water from sammying is recycled in the following pickling run and discharged each day.

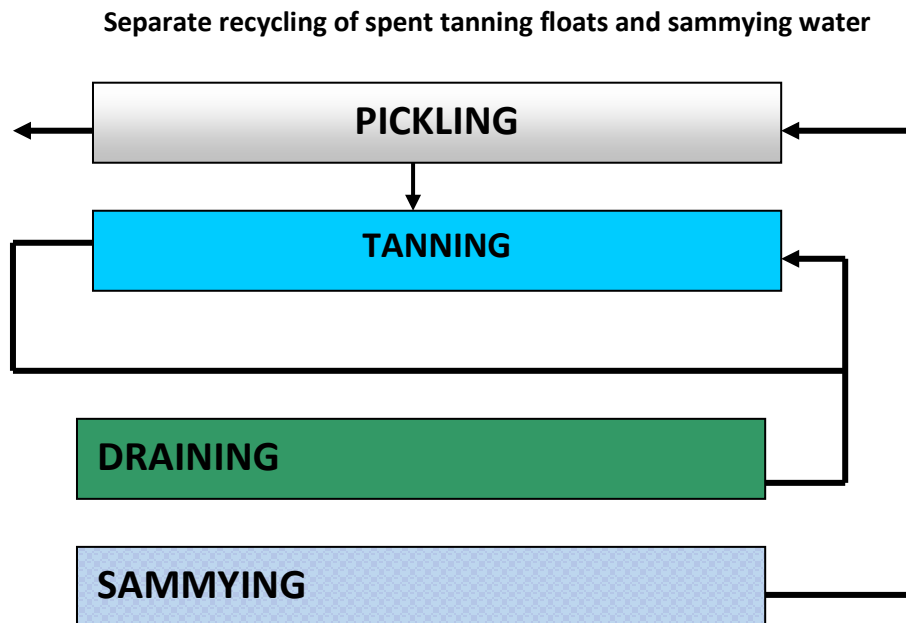

In all cases it is important to remove leather fibre and other undissolved impurities by filtering the recycled floats which is why all of them require installation of storage tanks, pumps and filters.

The build-up of neutral salts normally stabilizes after five cycles; there are no indications of accumulation of less reactive or inactive chrome complexes. However, in direct chrome recycling balancing the float volumes might be a problem because the float volume required in the pickle is lower than the total volume of spent tanning float, draining and sammying effluent. It is often overlooked that usually the discharge of the spent float after delimiting and bating is incomplete and that the water content in pelt is higher (70%) than that in wet blue (55%). Furthermore, adding pickle acids and basifying agents also increases the volume of recycled spent floats. This excess float must be discharged with other effluents or, much better, used in re-tanning or taken for chrome recovery by precipitation.

Table 22. Overview of direct chrome recycling

Advantages	Disadvantages
<ul style="list-style-type: none"> • Significant reduction of Cr in waste streams • TDS reduction • Simplest form of reuse, low capital cost • No additional chemicals needed, low running costs • Can be operated indefinitely • Leather quality not affected 	<ul style="list-style-type: none"> • Build up of chrome liquor volume • Some changes of tanning process are needed • Requires very high level of process control • Tanned leather is darker

Recycling efficiency depends primarily on the completeness of float collection, the rate of float excess to be discharged and the recycling technique used. Efficiency of 90% from conventional chrome tanning is easily attainable, but with a good collection system and more sophisticated recycling techniques 95 - 98% efficiency is possible. This results in a decrease of chrome load in effluent to 0.30 - 0.75 kg Cr/t w,s. hides and the chrome concentration in mixed waste water streams in the range of 10 - 25 mg Cr/l for water consumption at 30 m³/t hides.

A practical case of a comprehensive direct recycling system in a South American tannery is shown in the next flow-chart.

Figure 41. A practical example of direct chrome recycling system

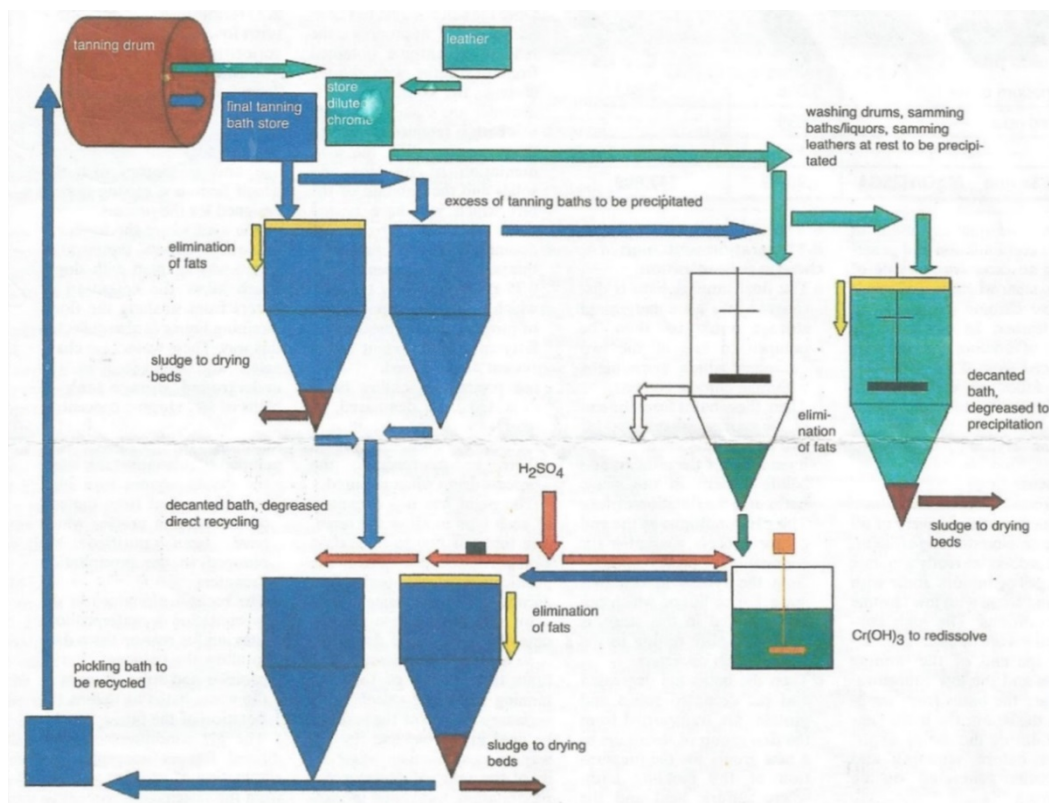

Source: J.M. Salazar, *Recycling chrome liquors*. *Leather International*, Nov/Dec, 2008

Producers of high quality leathers in Europe tend to prefer high exhaustion over direct recycling claiming that there is a certain change in colour of tanned leather (wet blue) affecting the subsequent drum dyeing (especially in pale colours) and that the content of impurities (proteins, grease) is increased. They also believe that the economies are in favour of (good) high exhaustion.

10.3.2.4. Chrome recovery and reuse

An indirect method of chrome recycling is chrome recovery from spent tanning floats by precipitation, re-dissolution with acid and subsequent (re)use avoiding an increase in float volume. Also, if the recovered chrome contains too many impurities, it can be simply dumped. Any alkali precipitates chrome salts; however, the stronger the alkali, the faster the rate of reaction and the slower the rate of coagulation.

Rapid: Precipitation with sodium hydroxide or sodium carbonate, polyelectrolyte for enhancing coagulation/flocculation followed by thickening and dewatering (of the voluminous sludge) by filtration and ultimately re-dissolution with sulphuric acid. Such chrome recovery systems can be installed in (three) phases, from a very basic to a complete one producing chrome liquor of high quality.

Figure 42. Chrome recovery by precipitation with sodium hydroxide/carbonate

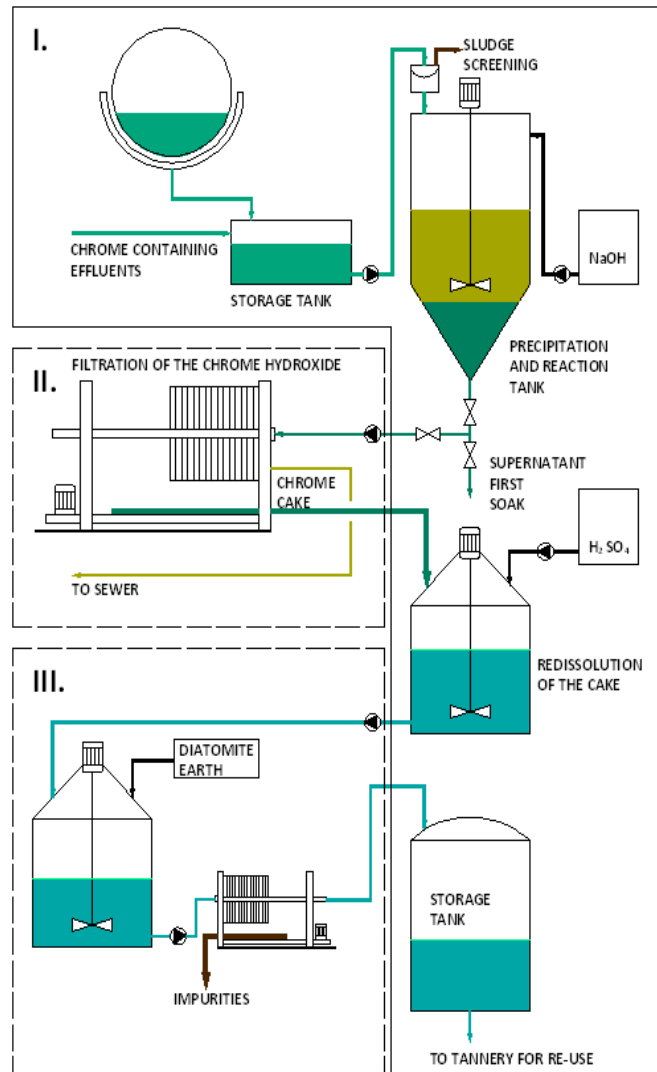

Chart by M. Bosnić

Slow: Precipitation with magnesium oxide, suspension settling, decantation of the supernatant and subsequent acidification of the relatively dense precipitate. This is a great advantage in that there is no need for filtration, but purity and low solubility of MgO can be an issue.

Figure 43. Chrome recovery by precipitation with MgO

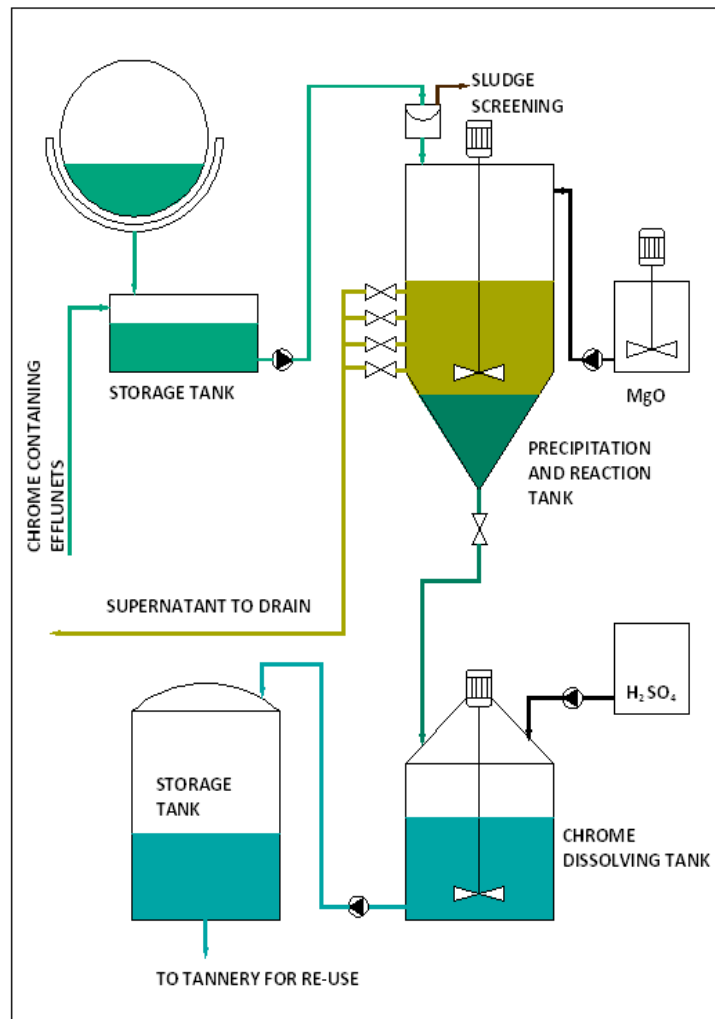

Chart by M. Bosnić

Some important points to be observed during the process:

- Good screening and fat removal by skimming
- Exact dosing of alkali
- The size and structure of MgO particles, continuous stirring of the slurry
- The optimum pH range is 8.5 - 9.0; the pH value should not exceed 10.0 because chromium hydroxide starts redissolving. However, in case of floats from high-exhaustion tanning, it is sometimes useful to raise the pH over 10.0, reducing it thereafter to 8.5- 9.0
- The right temperature for precipitation is 35 - 40°C; for high-exhaustion tanning 60 - 80°C may be needed (the greater the concentration of masking agents, the higher the temperature required).
- The chrome filter cake or slurry are dissolved by concentrated sulphuric acid added at a rate of 2 kg or more per kg chrome oxide on a continuous basis while stirring until pH 2.5 is reached.
- The cake should be redissolved as soon as possible, as it becomes less soluble on standing.

- After adjusting its basicity, the tanning liquor is stored ready for re-use in a separate tank. The problem of staining while using the recovered chrome is a consequence of insufficient reduction of astringency in the reused spent float or inadequate solubilisation of the chrome precipitate.

Except for high quality leathers, mixing 70% of fresh and 30% of recovered chrome gives satisfactory results; this ratio well coincides with 25 - 30% of the chrome offer that is actually recoverable.

Approximately 30% of the chrome offer can be reused and saved by means of a recovery technique using precipitation when conventional tanning is applied and 2.4% of the chrome offer is discharged. In the case of a high-exhaustion tanning, approximately 9% of the chrome offer can be reused and saved, while discharging is only 0.7%. The effects of the chrome recovery/reuse on decrease of chrome discharged in effluent at the typical offer level of 2.0 % Cr₂O₃ on pelt weight, i.e. 2.2 % Cr₂O₃ on w.s. weight, are shown below.

Table 23. Influence of chrome recovery/reuse upon tanning/re-tanning efficiency and amount of chrome discharged in effluent

	Tanning/Retanning	
	Conventional	High-exhaustion
Efficiency %	97.6	99.2
Load discharge kg Cr/t w.s. hides	0.36	0.12
Concentration in mixed effluent, mg Cr/l at 30 m ³ /t w.s. hides	12	4

Correctly performed chrome recovery/reuse reduces the chrome load in effluents to 0.12 - 0.36 kg Cr/t w.s. hides, whereas the chrome concentration in the effluent ranges between 4 and 12 mg Cr/l. Chrome in unrecovered spent floats, leather fibres (buffing dust), the supernatant and/or filtrate with a chrome content of 1 - 10 mg/l are sources of the residual chrome concentration in effluent; to bring it down to 1 mg Cr/l (the norm prevailing in Europe), the residual floats from washing, neutralisation and fatliquoring must also be precipitated.

Table 24. Overview of chrome recycling by precipitation

Advantages	Disadvantages
<ul style="list-style-type: none"> • Significant reduction of Cr in waste streams • More similar to using fresh chrome than recycling, very little changes • No volume build up • No additional chemicals needed, low running costs • Can be operated indefinitely • Leather quality not affected 	<ul style="list-style-type: none"> • TDS increase • Requires higher level of process control • Additional chemicals needed, higher running costs • More complex plant than for recycling, higher investment costs • Tanned leather is darker

Recovery without reuse

For nearly full elimination from residual floats/effluent emanating from neutralisation, re-tanning, fatliquoring and dyeing, the chrome they contain has to be precipitated but due to presence of organic substances this chrome cannot be reused. For this purpose calcium hydroxide, sometimes in combination with ferric and/or aluminium salt and an organic polyelectrolyte is mostly used.

In other words it is not easy but the amount of 3 kg Cr/t w.s. hides or the concentration of 1 mg Cr/l at water consumption of 30m³/t w.s. hides are attainable. The operational chemical costs will be higher by about 30%; at the same time some 30% of the chrome offered in the tannage will be also be saved.

10.4. Summary

In the traditional process ultimately less than 50% of the chrome input is to be found in leather while the rest is disposed in solid/liquid waste streams. Also, normally only 60 - 80% of the chrome offer is utilised in tanning.

In practice, in addition to the optimisation of the key parameters of the conventional process there are three principal approaches to maximising chrome utilisation: high exhaustion based on the modification of the tanning process; direct recycling of tanning floats; and chrome recovery/reuse after its precipitation and re-dissolving.

Optimisation:

Mechanical action, chrome concentration, chrome offer, pH, temperature and reaction time are the main parameters to be optimised. The chrome offer as low as 1.7% Cr₂O₃ on pelt weight is possible; short float, gradual basification and end-values up to 40 - 45°C and pH 4.0 - 4.2 advantageous.

High exhaustion: based on modifications to the tanning process:

It is achieved by masking the chrome tanning complexes and increasing collagen reactivity. Actually, a combination of process modifications and process parameter optimisations are the basis for modern high-exhaustion chrome tanning processes. Depending on the pelt thickness, the chrome offer can be reduced from a standard level 2.0% Cr₂O₃ to 1.3% Cr₂O₃ on pelt weight, chrome utilisation can go up to 98% without affecting the leather quality and leaching in post-tanning operations is also minimised; an improved drum drive system and an increased level of process control are needed. Chrome discharge can be reduced to only 0.4 kg Cr/t w.s. hides.

Direct recycling of spent floats:

It is the simplest form of reusing chrome using several recycling techniques. Depending on the process control and sophistication level efficiencies, between 90 and 98% can be attained. A certain constraint is a build-up of excess liquor volume.

Chrome recovery/reuse:

It is an indirect way of chrome recycling. The residual chrome contained in spent floats is recovered by precipitation with an alkali and separation of suspension to be ultimately re-dissolved in acid for reuse. Dewatering filtration is needed if the alkali used is sodium hydroxide or sodium carbonate but not for magnesium oxide. However, with this method there is increase in TDS level in effluent.

The choice of the chrome maximisation method depends on individual conditions in the tannery and no explicit recommendation can be given about the best option; each tannery has to devise an optimal technology for applying the chrome liquor recovered. For example, if the tanning of grain leather is carried out using a powder tanning agent, the chrome liquor recovered can be used for split tanning.

Table 25. Advantages and limitations of high-exhaustion chrome tanning

Advantages	Limitations
<ul style="list-style-type: none"> • Savings in chrome used • Reduced level of chrome in waste streams • Reduced level of sulphates in waste streams • Reduced level of water consumption • High chrome fixing, leaching minimised • Sammying immediately after leather unloading • Flexible, applicable to any type of leather • No loss in leather quality 	<ul style="list-style-type: none"> • Deliming should be as complete as possible • Longer running time needed • Higher temperature required • Slip agent needed to avoid abrasion of grain • Improved drum drive • Increased level of process control needed • Higher running costs

Table 26. Advantages and limitations of chrome tanning with float recycling

Advantages	Limitations
<ul style="list-style-type: none"> • Savings in chrome used • Reduced level of chrome in waste streams • Reduced level of neutral salts in waste streams • Reduced level of water consumption • No additional chemicals needed • Simplest form of reuse • Can be operated indefinitely • Flexible, applicable to any type of leather • No loss in leather quality 	<ul style="list-style-type: none"> • Build up of excess liquor volume • Mechanical pretreatment of waste streams required • Some change to tanning procedures needed • Increased level of process control needed • Some differences in leather colour possible • Some capital costs needed • Slightly increased running costs

Table 27. Advantages and limitations of chrome tanning with chrome recovery/reuse

Advantages	Limitations

Advantages	Limitations
<ul style="list-style-type: none"> • Savings in chrome used • Reduced level of chrome in waste streams • Close to using fresh chrome • Minimum procedure change in tanning • Treating all liquors • Flexible, applicable to any type of leather • Can be operated indefinitely 	<ul style="list-style-type: none"> • Mechanical pretreatment of waste streams required • Increased discharge of neutral salts • Additional chemicals and man power required • Increased level of process control needed • More complex plant needed • Higher running costs • Higher capital costs

10.5. Comparison of chrome balance:

i) Conventional tanning and/or chrome retanning: at the chrome offer of 15-17 kg Cr/t w.s. hides, 40-45% of the chrome offer remains in the leather, 26-30% in the solid waste and about 30% in effluent, while 21-24% of the chrome offer can be recovered and reused.

ii) High-exhaustion tanning and/or chrome retanning: with chrome offer of 10-13 kg Cr/t w.s. hides, 57-60% of the chrome offer remains in the leather, 32-38% in the solid waste and 3-8% in effluent while only 1-5% of the chrome offer can be recovered and reused.

The lowest practically attainable amount of chrome in effluent lies somewhere between 0.3 - 0.4 kg Cr/t w.s. hides so that at 30 m³/t w.s. hides, the chrome concentration ranges between 10 and 14 mg Cr/l.

Since worldwide the limit is mostly within the range of 1-4 mg Cr/l, in addition to chrome recovery it is also necessary to precipitate chrome from all waste streams from both tanning and post-tanning operations. Calcium hydroxide combined with ferric and/or aluminium salt and some organic polyelectrolyte is considered the most suitable precipitant. Only after precipitation a concentration of about 1 mg Cr/l (corresponding to an amount of 0.03 kg Cr/t w.s. hides) can be attained.

In that context the Best Available Technology – Associated Emission Levels values indicated by EU-BREF 2013 might be of interest:

Table 28. BAT-AELs for total chromium and sulphide emissions through indirect discharges of waste water from tanneries into urban waste water treatment plants

Parameter	BAT-AELs
	mg/l
Total chromium (as Cr)	< 0.3 – 1
Sulphide (as S)	< 1

10.6. Wet blue leather

Chrome tanned leather, not neutralized and certainly in wet conditions have become a well-established commodity in world trade. The key parameters (Volatiles, Oil & Grease, ash chromium oxide, hide substance) are nearly standardized¹⁵. However, more and more wet blue hides are made according to detailed specifications for a particular buyer.

In addition to considerations mentioned earlier, a very important environmental/OSH aspect in the case of wet blue is the application of fungicides essential for long(er) transportation and storage.

Nowadays the main active components in wet-blue fungicides are:

para-chloro-meta-cresol (PCMC)
 ortho-phenylphenol (OPP)
 2-(thiocyanomethylthio)benzothiazole (TCMTB)
 2-n-octylisothiazolin-3-one (OITZ)
 2-benzimidazolyl-methylcarbamate (BMC)
 2-mercaptobenzothiazole (MBT)

Tanners have to make sure that the use of fungicides is in conformity with national and international regulations. For example, the OPP and PCMC are used in both cosmetic and food industries and are relatively safe for humans and the environment; yet the OPP is on some Restricted Substances Lists. The TCMTB is more toxic and does not control some moulds.

Figure 44. Wet blue sammying machine, seven cylinders, six sammying points

(Suitable for hides with hump)

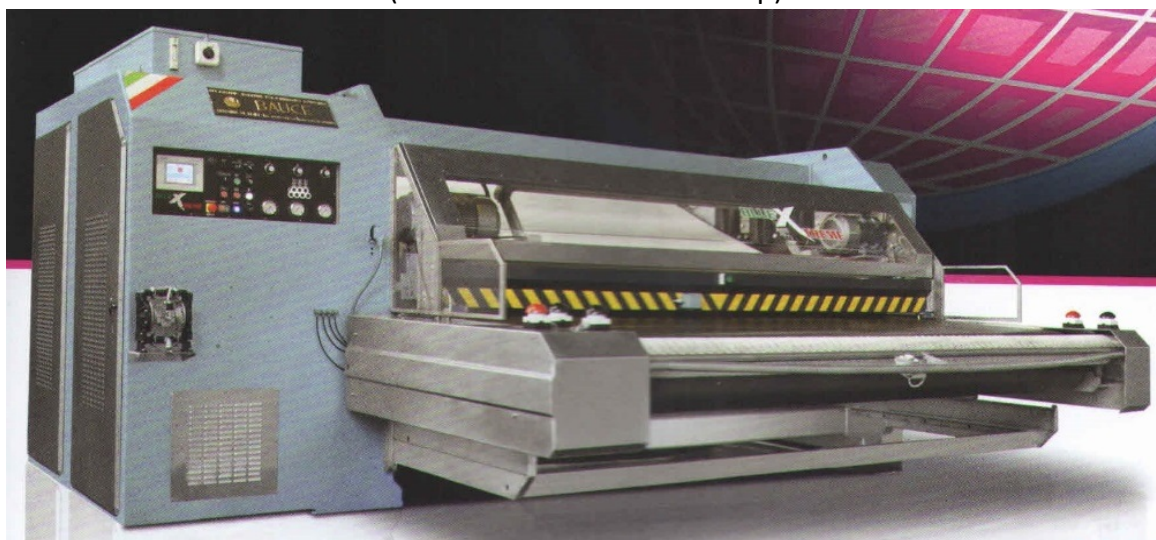

Front view

¹⁵ See the INTERNATIONAL CONTRACT No. 6 - HIDES & SKINS, ANNEXE C - WET-BLUE HIDES & SKINS, WET- BLUE SPLITS by the International Council of Hides, Skins & Leather Traders' Associations (ICHSLTA)

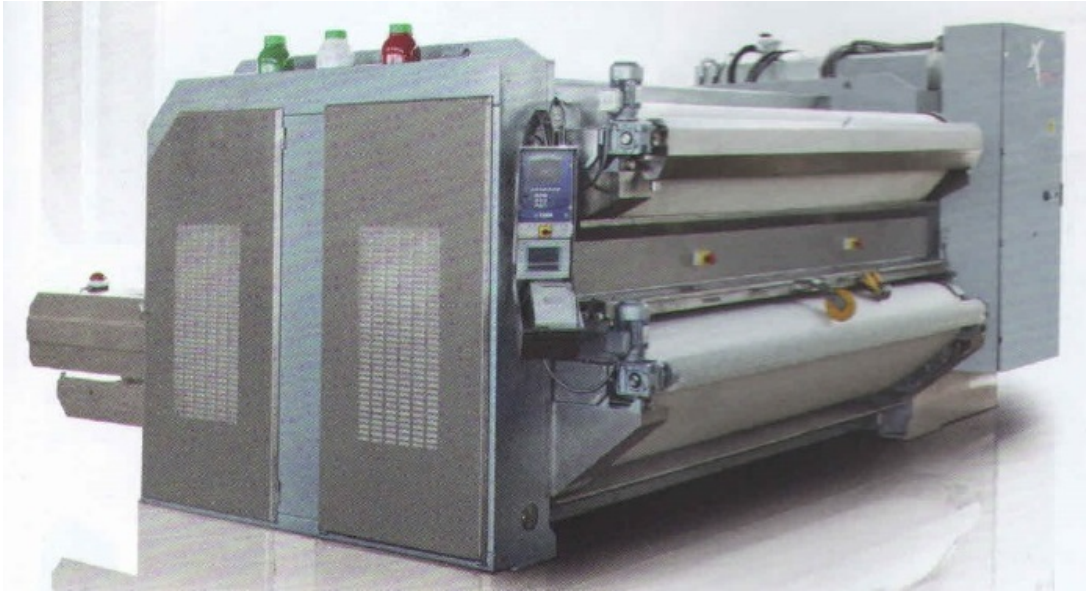

Rear view

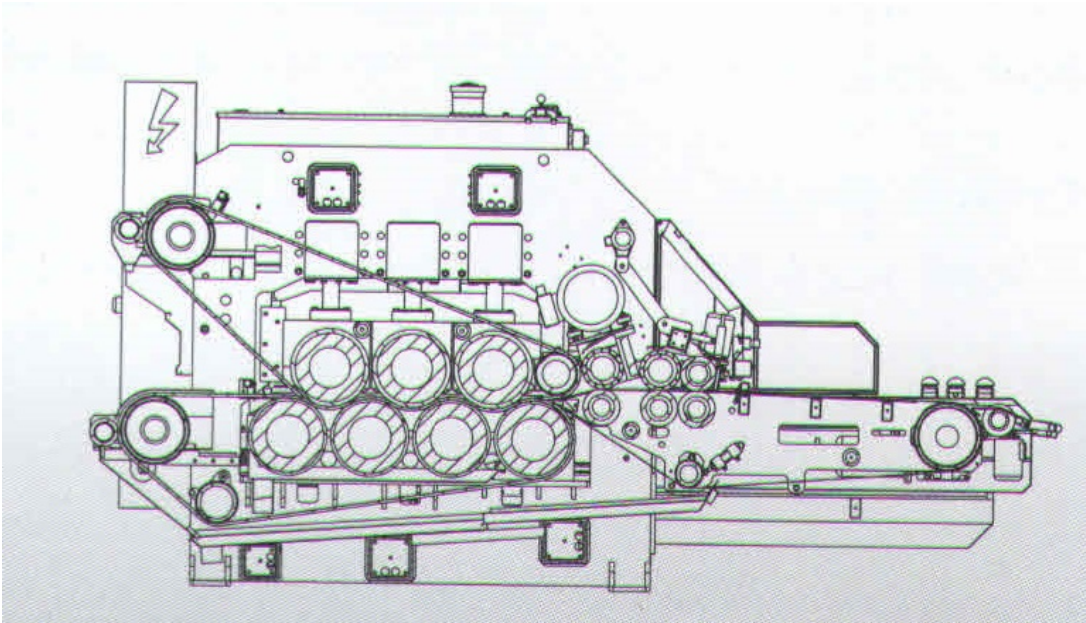

Cross section

Source: Bauce TRI.MA, World Leather Dec 2014

11. PRETANNING AND WET-WHITE CONCEPT

The original driving force behind the wet white concept was minimisation of production of chrome containing solid waste. It introduces a pretanning step with the view of making an intermediate product (shrinkage temperature normally around 80°C) with a partly stabilized structure that should permit mechanical operations, transportation and storage. More recently this pretanning – wet white concept is more and more used for the production of chromium-free leather for specific applications.

Figure 45. Flow chart of pretanning and wet white tanning

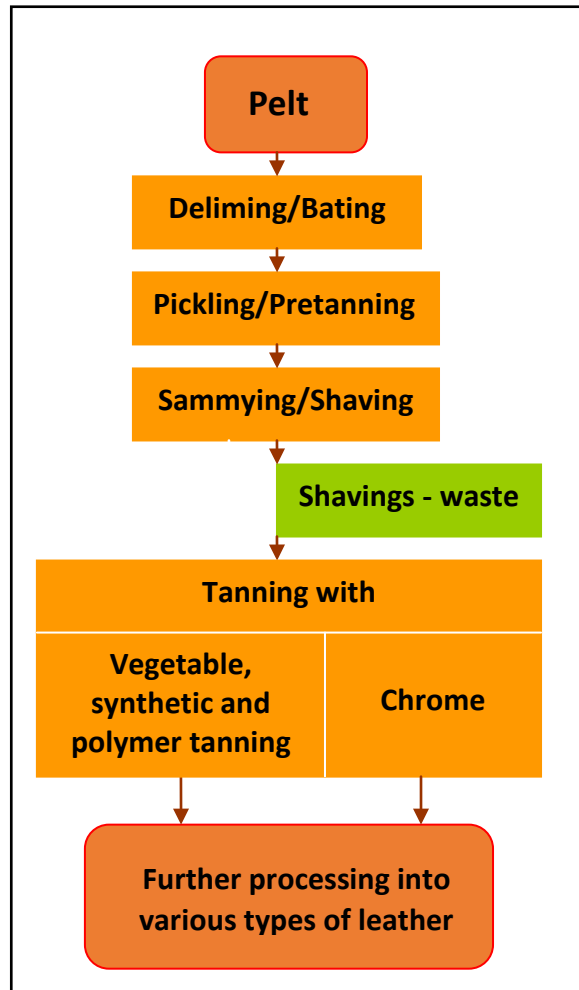

Source: Based on BASF Handbook

Many chemicals and their combinations have been proposed and used for pretanning: aluminium and titanium salts, silicon dioxide gel, polyacrylates, syntans, glutaraldehyde derivatives and other tanning agents. The bonding of aldehyde based agents is mainly on amino groups of collagen. The minimum dosage is 1.25% aluminium oxide or 1.0 – 1.5% glutaraldehyde or 0.75% titanium oxide.

One of the more recent systems is (pre)tanning with polycarbamoylsulfonate (PCMS) vigorously promoted under the proprietary brand name X-TAN. The bonding mechanism is shown in the next figure.

The main advantages claimed for the intermediate product obtained are good physical properties, easy sammying and shaving (including metal-free shavings), full reaction/exhaustion of the tanning substances and their environmental friendliness, lower TDS and COD in comparison with glutaraldehyde tannage, good temperature stability, storability and re-wet ability, resistance to yellowing and uniform penetration of dyes.

Rather similar advantages were also claimed for the proprietary metal- phenol- and aldehyde-free system branded EasyWhite Tan: following the conventional delimiting and bating but without pickling, the tanning agent is added to a very short float (10-30%) at pH 7-8.5 in one single addition and the process is completed after 8 hours of tanning time at pH 5.0. There is no basification or separate fixation.

Figure 47. The suggested tanning mechanism of the EasyWhite Tan method

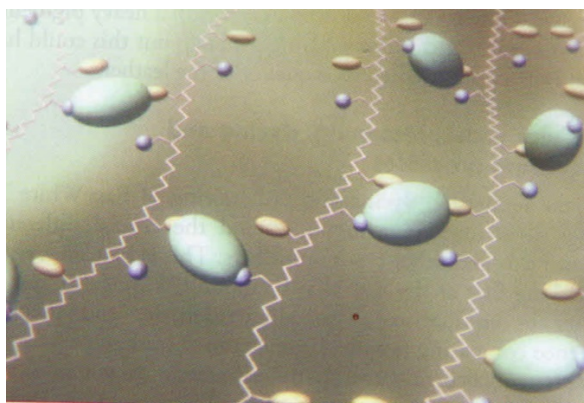

Source: M. Bartle, C. Reineking, Clariant, World Leather, Dec 2011

A great advantage of the wet white (pretanning) concept is that only the part of pelt that will end up as leather is tanned which *a priori* reduces the amount of tanning agent used. For example, only about 9.5 kg Cr_2O_3 /t w.s. hides are needed for the main chrome tanning stage instead of the usual 21 kg Cr_2O_3 /t.

It is also much easier to utilize and/or dispose of solid waste or, rather, by-products (unusable splits and shavings) resulting from mechanical operations of pretanned material; for example, being organic materials they can have excellent value as fertiliser. However, only pretanned by-products have some limitations as they tend to become putrid and gluey.

Since pretanning changes the physical and chemical characteristics of the leather, it can also be used as a mechanism to improve chrome uptake and thus reduce the chrome input, reportedly from 8% to 5% on the basis of pelt weight.

Pickling and pretanning can be combined, although pickling is not always necessary. Depending on the chemicals used, pretanning does not necessarily change the main leather characteristics nor limits the choice of further processing (chrome, vegetable or resin tanning).

Achieving accurate splitting and shaving in wet white condition can be somewhat difficult; some believe that this is compensated by comparably tighter grain.

For full assessment of wet white certain aspects cannot be overlooked. Retanning of wet white material requires higher amounts of retanning agents (e.g. syntans or vegetable tanning agents) than for chrome tanning. Some pretanning agents can be the cause of serious environmental concerns; for example, the hazards associated with aluminium due to its good solubility. Furthermore, in pretanning with glutaraldehyde fungicides are required in doses higher than those for chromium tanning and precipitation of chromium during effluent treatment is affected if aldehydes are present in the effluent stream.

Table 29. Overview of pretanning – wet white concept

Advantages	Limitations
<ul style="list-style-type: none"> • Chrome-free trimmings, shavings • Easier disposal of unusable splits • Tanned is only part of the pelt that will end up as leather • Lower consumption of chemicals • Better chrome uptake in the main tanning • Better grain tightness 	<ul style="list-style-type: none"> • The costs (additional operations, chemicals) might be higher • Splitting & shaving might be difficult and less accurate (sponginess) • The colour of the (final) wet blue can be different (greener) • In comparison with wet blue slightly higher carbon footprint (CT) • Higher dosing of fungicide required • Commercial acceptance of wet white still rather low

For a variety of reasons, including difficulties associated with splitting and shaving, commercial acceptance of wet white technology is low.

12. OTHER TANNAGES

12.1. Mineral

Aluminium III, Zirconium IV and titanium IV (white) and titanium III (coloured) based.

Aluminium, zirconium and titanium tannages differ from chrome tanning because there are cross-links with various groups (covalent, ionic, hydrogen bonds). These tannages cannot be considered as substitutes for chrome tanning since they give leathers of very different (generally inferior) characteristics.

Aluminium (III) tanning gives a nice white leather but inadequately water- or heat-resistant; thus, nowadays its use is limited to specific purposes (glacé leather for gloves, fur production), to pretanning or in combination with chrome tanning to increase the uptake of chromium. Aluminium tanning is also combined with vegetable tanning to increase the shrinkage temperature. The typical ratio is 6-7% mimosa tannin and 1% Al_2O_3 ; a similar dosage or less for additions in chrome tanning. Aluminium salts can also be combined with aldehydes such as (modified) glutaraldehyde.

Zirconium (IV) tanning, mostly with zirconium sulphate, gives white, strong and stable leather. Tanning starts at the lower pH (1.3 – 1.5) than for chrome tanning; citric acid can be used as a complexing agent to achieve a lower pH. To prevent swelling at least 7% salt is needed based on pelt weight. In practice the use of zirconium salts is limited to combinations with other tanning agents, primarily chrome.

Titanium salts, usually sold as proprietary titanium-aluminium complexes based products are good pretanning and retanning agents. Again, they are mostly used successfully in combination with other mineral tanning agents. Ammonium titanyl salts increase the nitrogen load in the waste water.

12.2. Organic

The main categories are:

- i) the traditional vegetable tanning (with wood, bark or leave extracts);
- ii) those based on reactive organic compounds (formaldehyde, glutaraldehyde and modified glutaraldehyde) normally in combination with vegetable or synthetic tanning agents; oil tannage;

12.2.1. Vegetable tanning

Vegetable tanning uses plant extracts from either hydrolysable pyrogallol (myrobalan, oak, sumac, chestnut, etc.) or from condensed, catechol based tannins (mimosa, quebracho) group.

Its main traditional use is in production of sole leather for high quality shoes, leather goods, harnesses, saddlery, much less for upholstery. However, use of vegetable tanning extracts is nowadays almost a regular feature in various combinations of tanning, primarily in retanning, sometimes in pretanning, too.

The widely used vegetable tannin extracts are mimosa, quebracho (the soluble type), chestnut (sweetened), myrobalans and valonia; tara tannin extract is gaining in importance as an efficient agent in the prevention of conversion of trivalent into hexavalent chromium (finished) leather. Typically, they are spray dried or concentrated to contain 60 – 70% of active tanning matter, the rest being various gums, sugars, organic acids and mineral salts. Different tannin extracts lend to leather quite different properties and appearance; for optimum results they are often combined.

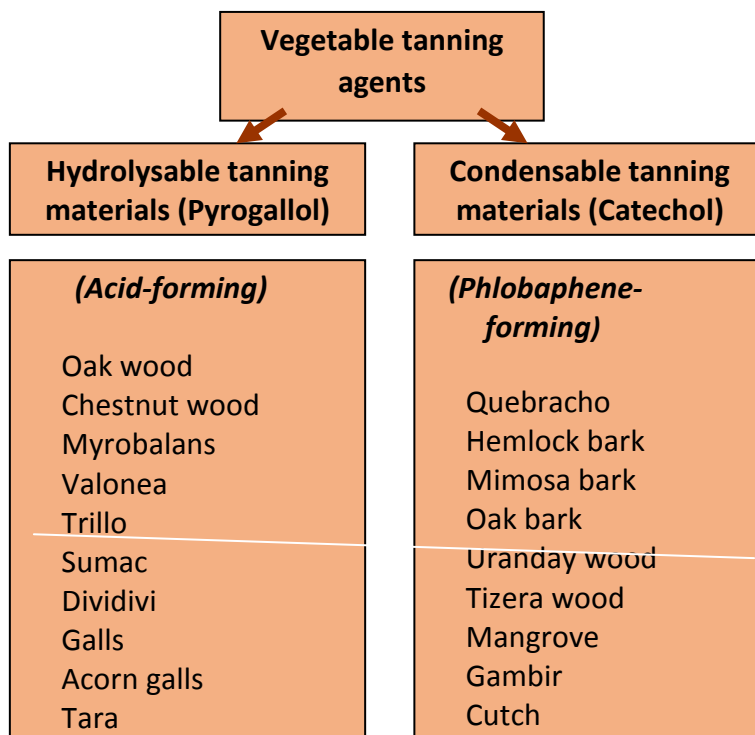

Figure 48. Vegetable tanning agents

The main quantities of vegetable tannins are now obtained from tree plantations (renewable sources); this is not valid for quebracho trees that grow scattered in the forests of South America. A dramatic increase in the use of vegetable tannins could result in consumption exceeding the supply.

More recently there were suggestions to consider spruce and birch, traditionally used in Russia for making leather of outstanding properties; vast spruce and birch forests in Russia and Scandinavia would ensure a nearly unlimited supply of renewable sources. The fact that up to five times more spruce agent than mimosa is needed to achieve the same level of tanning compounded by apparently complicated logistics possibly explains why this option has failed to attract commercial interests.

Another concept, branded Wet-Green, based on the utilization of residues from olive harvesting and olive oil production having (pre)tanning potential¹⁶ is being promoted but to date there are no signs of wider acceptance at the industrial scale.

¹⁶ Presumably based on reaction of oleuropein (a secoiridoid glycoside) ultimately reacting with lysine groups on protein.

Due to the duration extending from several weeks to even months, the centuries old pit tannage is almost entirely replaced by drum and combined pit and drum tannage; one alternative is the Liritan pit system that includes pretanning with sodium hexametaphosphate (Calgon).

In contrast to chrome tanning, vegetable tanning requires large amounts of tanning agent (extract), typically 40 – 50% on pelt weight; the overall uptake rate is about 50 – 70% of the tanning extract offer. Thus, while one tonne of raw hide gives about 200 – 250 kg of chrome-tanned leather, it gives 600 – 650 kg of sole leather. Water consumption is about 3 – 5 m³/tonne of pelt weight, the traditional pit tannage having a higher consumption than the drum processes.

Since the unusable splits, shavings and later on buffing dust do not contain any minerals, they can easily be utilized and/or disposed.

12.2.1.1. Emissions, pollution load

The main components of emissions and pollution load in effluent are:

- Residues of the tannin extract not bound to leather
- Soluble non-tannins present in the readily usable tannin extract
- A very high COD load (up to 220 kg/tonne hide) of low biodegradability (recalcitrant COD)
- Dark, unpleasant colour and phenolic compounds of these effluents
- Large amount of sludge both from tanning and later on from (biological) treatment

Table 30. Waste water volume and pollutant loadings per tonne of raw hide or skin from vegetable tanning including pickling, washing, and bleaching

Quantity per tonne of hide or skin	Counter current pit	Drum	Salt-free pickling
Water volume, m ³	3 – 4	3 – 4	
Total solids, kg	110 – 200	65 – 100	
Suspended solids, kg	10 – 15	10 – 15	
BOD ₅ , kg	40 – 75	25 – 35	
COD, kg	120 – 220	70 – 110	
Chloride (Cl ⁻), kg	50	?	4

Source: BREF 2013, Frendrup

Contrary to widely spread misperceptions, vegetable tanning agents, syntans, and aldehydes can cause serious damage to surface waters due to their low biodegradability and their toxicity to aquatic life.

12.2.1.2. Cleaner methods

The main aim of cleaner methods in vegetable tannage is the increase of the uptake of vegetable tannins, the corollary of which is a simultaneous decrease of pollution load and, in particular, of recalcitrant COD. For commercial reasons another target is the shortening of the (long) tanning process. This is generally achieved by:

- Switching to drum or pit-drum tanning (mentioned earlier)
- Use of short floats and closed loops in drum tanning releasing very little waste water
- Pretanning with various chemicals and auxiliaries (polyphosphates and/or syntans) improving the penetration and uptake; their cost is more than compensated by shorter processing time.
- Ex-lime splitting (already traditionally adopted for vegetable tanning)

12.3. Chrome-free tanning – Tannages with syntans and other synthetic organic compounds

The drive for chrome-free leather principally comes from the automotive industry; it is claimed that particular properties like low dry-shrinking of leather are important to them. Very relevant is also the pressure exerted on the public by certain groups and organisations with strong misperceptions about chrome tanned leather and poor understanding of deficiencies of some chrome-free tannages, including, in particular, their inferior environmental performance.

Chrome-free tannages are generally based on the use of reactive organic compounds in combination with vegetable or synthetic tanning agents. Syntans are sulphonated condensation products of hydroxyl-substituted aromatic compounds (phenol, cresol or naphthalene) with formaldehyde and often with amides.

Chrome-free tannages are normally preceded by pretanning. Glutaraldehyde derivatives are used both in pretanning (production of wet white) as well in the main chrome-free tanning. For safety reasons, in the leather industry in Europe glutaraldehyde is mainly used in the form of a modified glutaraldehyde product.

12.3.1. Environmental aspects

Syntans with a lower impact on the environment (low levels of free phenol) are available commercially, but there are still some that are hardly biodegradable.

Normally, syntans have a very high COD, their degradation both in the course of effluent treatment and recipient water bodies are very slow (aerobically and anaerobically) and even the degradation products are strong and highly persistent and mobile pollutants.

Glutaraldehyde has bactericidal effects and is therefore also used as a disinfectant.

Glutaraldehyde is only degraded to a limited extent, has high toxicity and may influence biological treatment negatively if the concentration is high.

12.4. Oil tannage

Oil tannage has been used for the production of a specific type of leathers (chamois) such as leather for traditional Bavarian (Germany) folks costumes and hunting garment (preferably from deer hides) as well as for the washing of car windscreens.

In the original formulation tanning was carried out by using highly unsaturated cod oil that was driven into the hide and oxidized by strong mechanical action. Subsequently the excess cod oil was wrung and washed out with sodium carbonate. The dried leather had a specific yellowish colour and very pleasant feel. They could also be dyed.

Later on the original procedure was modified by introducing a pretanning step with glutaraldehyde and the oil oxidation was accelerated by blowing the warm air into the vessel. There are also commercial oil tanning agents mostly used for washable gloves and garment leathers with high tear resistance.

The cod oil releases a pungent smell and waste water discharge is highly COD loaded.

13. WET FINISHING

While the tanning stage basically converts a putrescible, easily degradable hide into a stable material, wet finishing lends to leather more specific properties (softness, basic colour, water repellence, etc.) important for its appearance and ultimate use. This explains why in practice there are so many variations of wet finishing (post-tanning) operations.

The main stages of typical wet finishing are neutralisation (deacidification), retanning, dyeing and fatliquoring. As a rule all of them are carried out in the same processing vessel (usually a drum) to be followed by a series of mechanical operations.

Figure 49. One of many variations of operations in preparation of wet blue for dry finishing

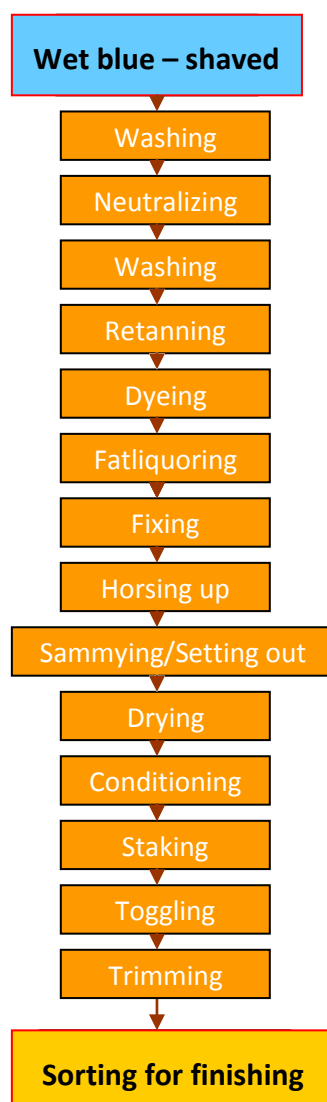

13.1. Neutralisation

The purpose of neutralization is to remove free acids present in tanned leather in order to prepare it for the subsequent stages i.e. retanning, dyeing and fatliquoring.

Since the pH is normally not raised to the neutral point, in reality it is deacidification. For soft leather and better dye penetration it is carried fully throughout the cross-section whereas partial deacidification, only to a certain depth, gives firmer leather. Excessive neutralization results in loose grain and empty handle; on the other hand, too low pH results in undesirable leaching of chrome.

Commonly used are mildly basic chemicals, mostly sodium carbonate/bicarbonate, sodium bisulphite and metabisulphite, sodium tetraborate (borax), sodium formate/acetate; dosing of a single or a combination of agents is up to 4% on the shaved weight.

Polyphosphates are usually used for deacidification of vegetable tanned leathers. In addition to retanning and/or filling properties, some syntans also have a neutralising effect.

13.2. Retanning

The retanning process is carried out for several reasons, the main being:

- To make the leather more uniform by filling the looser and empty parts, thus increase its cutting value
- To improve its buffing properties important for production of corrected grain leathers
- To improve the resistance to alkali and perspiration
- To improve the general feel and handle

The emphasis of the retanning process will depend on the type and quality of raw hides, desired leather properties and the customer's specifications. The selection of the retanning agent (or a combination of retanning agents) is also made accordingly.

A wide variety of chemicals can be used and they belong to the following categories: vegetable tanning extracts, syntans, aldehydes, mineral tanning agents (not necessarily chromium) and resins. They are used in nearly endless variations of combinations and ratios.

In accordance with what was stated earlier, the dosing also varies a lot, from 3% for clothing leather and up to 15% on the shaved weight for shoe uppers.

In the case of chrome retanning, carboxylic/ di-carboxylic acids and the respective salts as well as phthalates e.g. di-sodium phthalates (DSP) are often used as masking agents; the difficulties they cause with the precipitation of chromium in effluent have to be borne in mind.

Synthetic tanning agents (syntans) used in the retanning process include a wide variety of rather different chemicals which ultimately impart different properties.

Figure 50. Structures of aromatic and aliphatic retanning agents

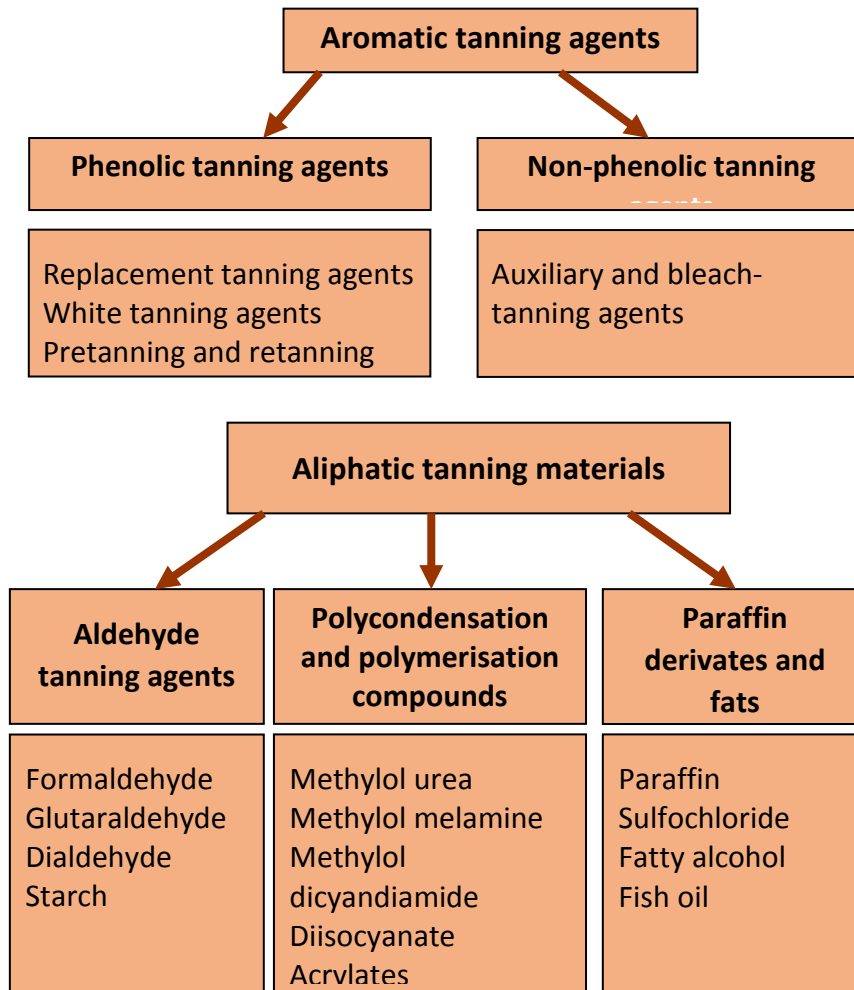

When selecting the syntan, in addition to characteristics it gives to leather, it is important to consider its environmental performance: residues not taken by leather can contribute to heavy COD effluent. To make it worse, very often the COD load they produce is not biodegradable and requires specific and costly tertiary treatment.

13.3. Dyeing

Obviously, the dyeing process should give leathers a uniform shade of colour corresponding to the customer's specifications, often using a piece of leather as a reference sample. Colour consistency from pack to pack is very important. Dyes are normally used as aqueous solutions and the process is mostly carried out either in wooden drums or in stainless (often three-chambers) dyeing machines; through-feed machines are met with rather limited acceptance by the industry while paddle dyeing is in practice used only for sheep skins.

Dyestuffs in the leather industry are mostly from the anionic (acid, direct, sulphur, premetallised), very seldom from the basic group. From the chemical point of view, the dyestuffs are predominantly azo- or anthraquinone dyes.

Metal complex dyes having metal such as iron, chromium, nickel, copper and cobalt as a central ion and one or two azo dye ligands are quite important in production of certain types of leather; it is believed that dyes containing lead and cadmium are no longer used in Europe.

Due to a very narrow range of colours, the use of vegetable dyes from the extracts of some trees (logwood, redwood) or leaves (sumac) is limited to some niche articles.

Nearly all leather dyes for drum application bind to leather by the ionic interaction between the anionic sulphonate group of the dye and the cationic amine group of the collagen. The formic, sometimes acetic acid is crucial for good fixing at the end of the dyeing process and they contribute towards improving colour fastness. Depending on the type of finished leather produced (aniline, corrected grain, shade), the quantities vary in a wide range, i.e. from 0.05 - 10%. Pigments, especially for white leathers, may also be added.

The dyestuff exhaustion rate depends on many factors: the type of tannage, dye used, auxiliary agents, water hardness, etc. as well as on the process parameters (mechanical action, concentration, pH, time, etc.).

For good results (levelness, shade depth) dyes are added in a dissolved state and in several portions. Long floats and lower temperatures help good distribution while short floats, higher temperatures, longer process time and the dosing of formic acid for fixation in a few portions help better fixing and exhaustion.

In balancing these conflicting effects the usual approach is to start at a lower temperature (e.g. 30°C) and towards the end of the process bring it above 50°C.

Due to high costs of the dyestuffs, dyeing is a very expensive operation and special efforts are made to achieve the highest bath exhaustion possible. In practice it means exhaustion of at least 90% but nearly complete exhaustion is also possible.

Dyeing auxiliaries

Being a very sensitive and demanding operation dyeing is normally aided by various auxiliary chemicals and agents such as surfactants, levelling agents, shade intensifiers, fixing agents, etc. They are mostly added separately but some can be included in the dyestuff.

Surfactants can be either dispersing agents (e.g. alkyl aryl sulphonates or ethoxylation products, condensates of fatty acids) or wetting agents (auxiliaries) which in turn can be anionic (alkane-sulphonates, alkyl aryl sulphonates), non-ionic (e.g. phosphoric acid esters), or cationic (e.g. alkyl aryl amine polyglycol ethers, amine and urea derivatives, etc.). The surfactants used in wet processes could increase the hydrophilic properties of leather. To rectify this, hydrophobic chemicals (e.g. silicones or organic chlorofluoro-polymers) can be used.

For appropriate use, it is important to understand their character and behaviour, for example, whether emulsifiers make oil-in-water (o/w) or water-in-oil (w/o) emulsion, stability, etc.

Organic acids, buffering salts and mixtures of these chemicals are used as **pH adjustment agents** whereas mixtures of alcohols of higher valence and neutral phosphoric acid esters act as **antifoaming agents**.

The main sequestering agents used to be nitrilo-tri-acetate (NTA), ethylenediamine tetra acetate (EDTA), polyphosphate (calgon) and carboxylic acids, but for example in the EU there are restrictions about their use.

After treatment and fixing agents are surface active substances such as cationic polyquaternary ammonium compounds, cationic formaldehyde poly-condensates and other nitrogen derivatives and some agents based on inorganic complexing agents and metallic salts.

Stripping agents are used generally on vegetable tanned leathers to level out the colour of the substrate prior to the dyeing operation. More rarely this operation is carried out on chrome tanned leathers. The chemicals used for this type of process are: salts releasing sulphur dioxide, oxalic acid, EDTA, bleaching syntans, etc.

Sometimes, usually in reprocessing, it is necessary to remove a certain amount of dye from the already dyed leathers. This is done using alkalis like sodium bicarbonate or ammonium bicarbonate or by bleaching using certain syntans.

13.4. Fatliquoring

Fatliquoring is important because it replaces the natural fat originally present in hide and lubricates the leather fibres in a way that gives the product-specific characteristics. Accordingly, the amount added varies from 3-15% on the shaved weight. Some fatliquoring (1-4%) can be done already at the pickling and tanning stages using electrolyte-stable cationic products, but the main fatliquoring takes place after neutralisation and dyeing.

Traditionally, the oils and fats used for this purpose were of animal (fish oil, neatsfoot oil, tallow) or vegetable (linseed, maize, cotton seed) origin but for some time now commercial synthetic products derived from mineral oils have been in wide use. To make them water soluble, both animal and vegetable oils and aliphatic hydrocarbons are sulphonated. For good characteristics chlorinated hydrocarbons have also been used; however, the use of some (stabilized by organic solvents) is recently under close scrutiny because of their poor environmental performance: they significantly contribute to higher AOX values and multiple chlorination makes them virtually non-biodegradable.

For good dispersion and penetration fatliquors are prepared as emulsions (mostly oil-in-water) with emulsifiers already incorporated into the fatliquor. To sustain solubility and emulsion the float temperature is 60-65°C. For good penetration and bonding it can be necessary to adjust pH using formic acid or ammonium. To achieve the silky nap expected from suede leathers, a small amount of cationic fatliquors can be added at the very end of the process.

A special category of fatliquoring is “stuffing”, a method applied in the production of heavy vegetable-tanned leather: sammed leather is drummed with a mixture of molten fat, the high temperature often sustained by the blowing of hot air.

Following the set of operations (retanning, dyeing, fatliquoring) leather is usually washed and then piled onto a “wheel-horse” to rest which helps to achieve a more uniform distribution of the chemicals, especially of fatliquors.

13.5 Specific performance and related agents

In addition to the auxiliaries mentioned earlier, there is a wide range of various substances, usually readily usable commercial products applied in wet finishing and imparting some leather type-specific performance:

- To reduce hydrophilic properties
- Waterproof properties
- Better wearing and abrasion resistance
- Oil repellence
- Lower gas permeability
- Anti-electrostatic properties

Substances used to achieve these aims are selected from different natural, mineral or synthetic oils and fats; polymers, poly-condensates and poly-addition products; metallic acid complexing compounds; silicon derivatives; perfluorinated organic compounds, etc. either as a single material, or more often, a combination of them.

More recently flame-retardant properties are also asked for. While leather cannot be considered a flammable material, leathers for special use (upholstering of aircraft, train, and public building seats, some safety shoes/gloves) can be treated with flame-retardants, usually at the wet finishing stage. The main categories of flame-retardants are:

- inorganic compounds (e.g. ammonium polyphosphates, ammonium bromide)
- halogenated organic compounds (usually brominated or chlorinated)
- organophosphorous compounds (phosphate esters, e.g. triphenyl phosphate)
- nitrogen-containing compounds (e.g. melamine compounds).

However, due to environmental/health risks flame-retardants from the polybrominated diphenyl ethers (BDE) category such as penta- and octa-BDE are already banned in the EU while others may be added to the list.

13.6. Emissions

The effluents from all wet finishing operations are normally collected jointly and that is why there are no specific data for each of its steps. Generally wet finishing contributes about 10 – 20% of the total COD in combined tannery effluent.

In comparison with emissions from the tanning stage that tend to be quite similar, emissions from wet finishing vary within a very wide range both within the same factory (depending on the type of leather produced) and among tanneries producing the same type of leather. This

is quite understandable if great variations in wet finishing technologies are kept in mind. Incidentally, the COD load from wet finishing in production of upholstery leather is usually higher than that from the production of upper leather. The pollution discharged with effluent from wet finishing mainly emanates from retanning and fatliquoring.

Table 31. Emissions to waste water from conventional post tanning operations

Pollutant	Emissions kg/ton of raw hide
Total Solids	65
Suspended Solids	7
BOD ₅	14
COD	20-30
Nitrogen, total	0.8-1
NH ₄ ⁻	0.6-0.8
Cr	1
Cl ⁻	2-5

Source: EU-BREF 2013

13.6.1. Emissions from retanning

The main pollutant here is the high COD emanating from:

- incomplete exhaustion of retanning agents;
- non-tannins contained in vegetable tanning agents;
- residual monomers contained in syntans and polymeric tanning agents.

Chromium stems from leaching of chromium from the main tanning process as well as from the chromium from retanning itself; closely linked to that are also emissions of inorganic salts present in chrome tanning agents and syntans. The other source of chromium is fibres from the shaving operation adhering to the leather surface that eventually end up in neutralisation and washing floats. Using a conventional technique, the amount of chromium in the waste water, derived from the post-tanning operations, is about 1 kg per tonne raw hide arising as shown in the following table.

Table 32. Sources of chromium discharges during wet finishing

Source	kg chromium per tonne of raw
Leaching	0.6
In fine leather fibres	0.4
In metal complex dyes	0.03

Source: Frendrup 1999

Figure 51. The share of post-tanning in total emissions

Chart by M. Bosnić

Retanning agents of the amino-resins type (urea- formaldehyde or melamine formaldehyde resins) used for their good filling properties contribute to the nitrogen load in the waste water at the level of about 0.2 kg per tonne of raw hide.

13.6.2. Emissions from dyeing

Emissions from the dyeing process are of comparatively minor importance and they are mainly to effluent although emissions to air and residues from dyestuff and auxiliaries to be disposed of cannot be disregarded. Yet, in the latter case, it is mainly occupational safety and health at the workplace (OSH) which is related to chemicals handling and, in particular, with dust control.

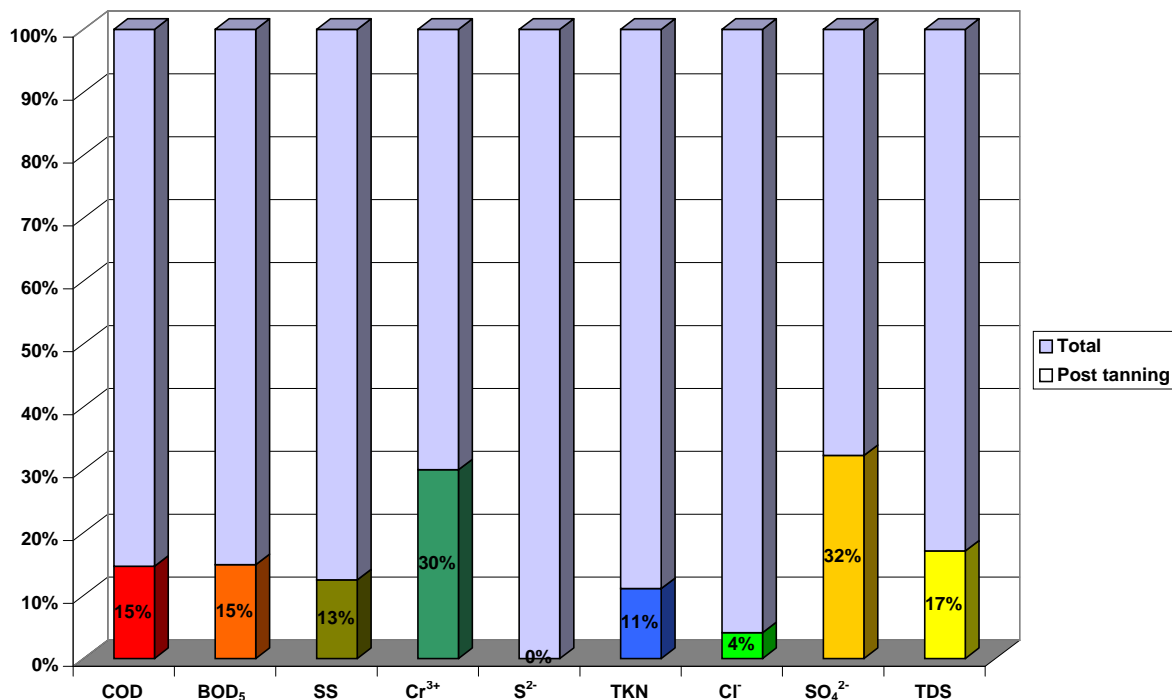
Chemicals not retained in leather and released to the waste water contribute to the COD load and, if one of those the halogen-containing dyes are used, to the release of the absorbable organic halogens (AOX).

However, dyes in the effluent are difficult to remove and coloured waste water (dye concentration of only 10 ppm is noticeable by the eye) is by the general public *a priori* considered very polluted. Actually the main negative impact of dyestuffs is that they can reduce the penetration of light; also, most of them have very low biodegradability.

By reductive cleavage of one or more azo groups, certain azo dyes can release some of the 22 aromatic amines specified in the restricted chemicals lists (RSL). The use of such azo

dyes has been strictly forbidden worldwide for quite some time and such dyes are no longer produced by reputable suppliers.

Metal complex dyes consist of a central metal ion and one or two azo ligands. The central ion can be iron, chromium, copper, or cobalt for leather dyes; they are needed to achieve good light-fastness as well as special colours. The amount of chromium from this source normally does not exceed 0.3% of chromium in leather or 0.03 – 0.05 kg chromium per tonne raw hide in the waste water.

Metal complex dyes containing lead and cadmium are no longer used in Europe. Due to its fungicidal and bactericidal properties, high concentrations of copper inhibit degradation.

Obviously, the residues of different auxiliary agents used at various steps of wet finishing end up in effluents (especially if their uptake is poor) and contribute to the pollution load, mainly COD.

Ammonium used as dye penetrator is an important contributor to the $\text{NH}_4\text{-N}$ load in effluent: it is in the range of 0.6 – 1.6 kg per tonne of raw hide. However, more recently ammonium is one of the key suspects for conversion of trivalent (Cr^{3+}) into hexavalent chromium (Cr^{6+}) in finished leather and leather articles.

13.6.3. Fatliquoring emissions

Emissions to the joint wet finishing effluent emanating from the fatliquoring and impregnating agents can be significant: obviously, they are the principal source of oil and grease. Furthermore, in addition to contributing to the COD and BOD load, chlorinated fatliquors also raise the AOX values.

In the EU the use of preparations containing more than 1% of chlorinated alkanes of chain length $\text{C}_{10}\text{-C}_{13}$ is banned.

13.7. Cleaner methods

13.7.1. Neutralisation

The amount of the neutralising salts should be optimised to ensure that the pH of the liquor and the leathers by the end of the process are close to each other, ensuring that as little as possible of the unused salt ends up in effluent. Rinsing after neutralisation should also be optimised to ensure good washing without excessive water consumption.

Screening of spent floats to remove chrome containing leather fibres is essential in reducing chrome content in the effluent. A lot of screening equipment, from very simple to rather sophisticated and suitable for large capacities is available.

13.7.2. Optimised retanning

Generally the idea is to achieve COD optimized and low- or salt-free retanning systems.

Before moving to wet finishing it is very important to allow sufficient time for proper “aging” (olification) of the tanned leathers as it will significantly reduce the leaching effect.

Concerning chrome retanning, there are strong voices that chrome retanning is actually a residue from the times when process controls were quite inadequate. Additional chrome tanning was a kind of safety step to avoid the risk of undertanning. With modern equipment (drums, chemicals and water dosing) and control tools this step might be unnecessary.

In any case, a high exhaustion method using appropriate masking agents in appropriate amounts (to avoid difficulties with the precipitation) together with the optimisation of process parameters (chemical inputs, mechanical action, pH, temperature, duration etc.) is considered a must.

A relatively low pH at the end of wet finishing helps good fixation of dyes and fatliquors (the pH could be brought down to 3.5). However, this is in conflict with retaining chrome because at the pH below 4 chromium could leach out from the leather.

For other retanning agents the focus is firstly on those that meet not only the desired leather quality properties but also with the best environmental performance - good biodegradability; after all, recalcitrant COD is one of the main evils in waste water treatment. Secondly, it is important to ensure the highest exhaustion rates and thus, ultimately, the lowest possible COD load. Finally, water and energy consumption are important parameters for the choice of the retanning process.

13.7.3. Optimised dyeing

Apart from avoiding the hazardous dyestuffs, the main aim of optimized dyeing is to ensure firm bonding to leather and thus the highest possible exhaustion of dyes and all dyeing auxiliaries. The target is usually to bring down the concentration of dyestuff in the effluent below 10 ppm. To that end short floats (100% on shaved weight) and a high temperature (60°C) are employed; also, to enhance the dye intensity amphoteric polymers are often used. As said earlier, completion of the dyeing process at a relatively low pH value, e.g. 3.5 helps the fixation but too low of a pH may result in chrome leaching.

To reduce and/or eliminate harmful particulate matter in the air in dye-handling areas (OSH!) after de-dusted powdered dyes (actually mixed with an anti-dusting agent, such as paraffin oil) liquid dyes are also being introduced.

In addition to the dyestuff itself, liquid dyes also contain water, diluents/fillers (chalk, syntans, polymers, etc.), surfactants and anti-foam agents. While dosing automation with liquid dyes is much easier and preferred by the OSH, some negative aspects cannot be overlooked: they need more storage space, their shelf-life might be shorter, transport and energy costs (heating!) are higher.

Ammonium can be replaced by other acceptable dye penetrators; furthermore, many believe that its use is not really of particular importance.

13.7.4. Optimised fatliquoring

More environmentally friendly fatliquoring in practice is focused on two areas:

- optimisation of process parameters to achieve the highest possible exhaustion level
- use of fatliquors which do not contain halogenated compounds

By selecting the appropriate fatliquor(s) for a certain type of leather, fine tuning of the float length, temperature, pH, etc. and by adding amphoteric polymers, it is quite possible to attain the exhaustion level of 90% and thus significantly reduce the COD load.

Fatliquors that do not need stabilization by organic solvents and do not add to the AOX load are already available. Methacrylates and silicone or modified silicone oils can substitute the hazardous short- and middle-chain chlorinated alkanes; for the time being there is still no adequate replacement for long-chain chlorinated alkanes needed for special applications.

Parameters	Specific emissions per unit of raw hide from advanced post-tanning processes kg/t
TS	30
COD	13 – 17
Chromium	0.1 – 0.4

Sequestering agents and wetting agents are problematic substances due to their ability to form stable complexes with heavy metals. Thus they not only prevent effective precipitation, but they cause the re-mobilisation of heavy metals from sediments. Some of these substances are hardly biodegradable and include nitrilotri-acetate (NTA), ethylene diamine-tetra-acetate (EDTA), polyphosphate (Calgon), carboxylic acids/dicarboxylic acids and their respective salts. Phosphoric acid esters are used as wetting agents and emulsifying agents. For example, tri-butoxy-ethyl phosphate is found in the effluents which is problematic due to its solubility in water and low biodegradation rates.

13.8. Dewatering, drying, conditioning, staking

The purpose of these operations is to prepare leather for dry finishing – the coating that will give it its final appearance and touch. In addition to local climate conditions/season and possible variations in the characteristics of the leather processed, the choice of dewatering and drying methods primarily depends on the type of leather produced because each technique has a specific influence on leather characteristics. Next in importance are area yield and energy consumption considerations and that is why there are many variations in both the type and sequence of dewatering and drying techniques.

Typical moisture content of leather at different stages:

After dewatering, ready for shaving:	30 – 45%
After drying:	8 – 15%
After conditioning:	20 – 30%

Dewatering by mechanical means should significantly reduce the water content and thus reduce energy consumption during the drying process. Forced drying is the most energy-intensive processes in leather making and may account for up to 45% of total energy consumption. Good dewatering also shortens the drying time.

Figure 52. Double felts combined sammying and setting out machine



Source: Rizzi

The currently prevailing dewatering techniques are sammying and/or setting out. Leather drying is an extremely complex process and a good understanding of theoretical principles and practical experience are needed to achieve the desired properties (e.g. feel, softness) and to balance other aims and parameters like area yield, energy and labour inputs, duration, etc.

Figure 53. Schematic cross-section view of jaw- and vibro- staking machines

Machines for dry finishing – operating principles

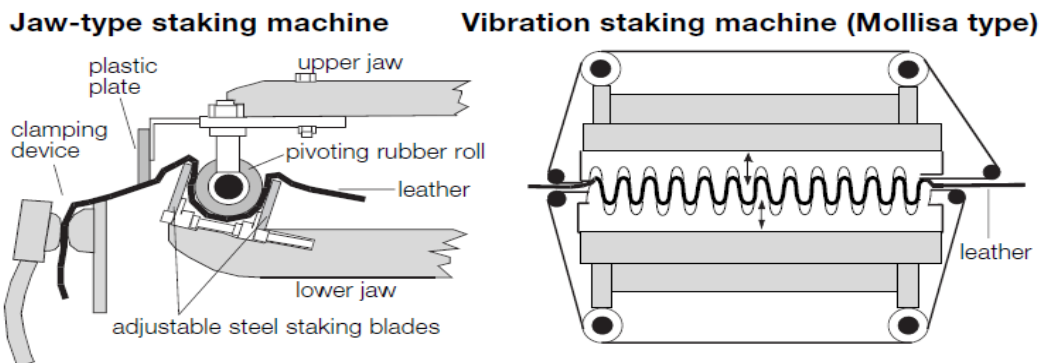

Source: BASF Handbook

Drying methods could be, somewhat arbitrarily, classified in the following manner:

- Natural, air-drying without supply of energy (hang-drying); overhead conveyers, open air
- Air-drying with or without supply of energy
 - Hang-drying in a channel, tunnel or chamber
 - Toggle drying
- Vacuum drying
- Paste drying

Figure 54. Vacuum dryer

Source: Escomar, World Leather Oct/Nov 2014

Infrared drying is more used in the drying of coated, finished leather while due to certain constraints, the use of high-frequency drying is quite limited.

As said earlier, each drying method has a very specific impact on leather properties: on one end is natural air drying which apart from the low cost lends particular softness ideal for (garment) nappa; unfortunately, natural drying is directly dependent on unpredictable variations in climate and is not quite compatible with high output and tight delivery deadlines.

On the other hand, hot air toggling and high temperature vacuum drying give excellent area yield but can easily result in leather with inadequate feel (emptiness).

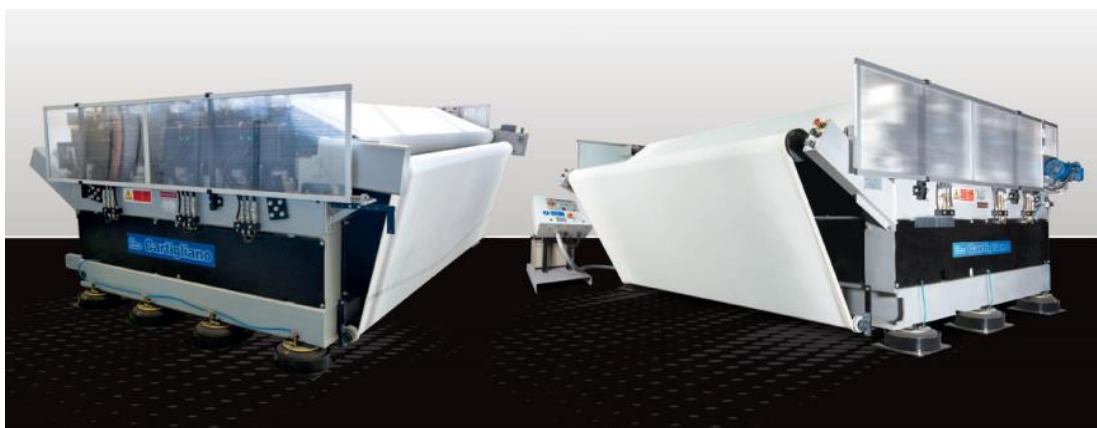
Figure 55. Vibro-staking machine

Source: Cartigliano, Italy

After drying, the leather is called crust and nowadays it is a tradable intermediate product, almost a commodity like wet blue.

Figure 56. A traditional toggle dryer



Source: www.carlessi.it

Improved drying methods

The conventional energy saving measures are better insulation of pipes and drying equipment and better monitoring and /control and optimization of the air temperature and humidity. For example, the same leather quality together with considerable energy savings can be achieved by improved ventilation and elimination of pockets and at lower air temperatures. Also, ideally drying equipment should be run continuously to avoid energy losses of reheating.

Figure 57. Toggle dryer, of the Cell Rotaring Conditioning (CRC) System, inside view



Source: Fratelli Carlessi, World Leather Dec 2014

Other methods to consider are:

- More efficient dewatering with modern machines; it is estimated that high performance sammying can save about 0.5 – 1.0 GJ/t raw hide.
- One time investment into larger drying capacities at lower temperatures; it can pay back through lower energy consumption.
- Use of the energy from renewable sources (e.g. solar energy) as a supplementary source
- Use of heat pumps

Table 33. Energy consumption with various drying methods

Drying methods	MJ/kg of evaporated water	
	Without heat	With heat
Theoretical	2.48	
Toggling	8.17	
Pasting	6.37	
Chamber drying	5.83	1.62
Vacuum drying	7.20	1.37
Through-feed drying	5.22	1.12
High-frequency	6.84	

Traditionally leather is taken for staking after the conditioning stage and with a humidity of about 30%. More recently a new approach with staking takes place immediately after sammying/setting with a water content of about 50%, alternatively after vacuum drying is being introduced. The reported advantages of the wet staking concept¹⁷ are that the fibre structure remains lubricated, the leather is opened more homogeneously, there is some area gain and less stress, and the subsequent drying process is more uniform.

Figure 58. Milling drum

Source: Erretre, World Leather Dec 2014

¹⁷ Promoted by the tanning equipment manufacturer Officine di Cartigliano, Italy

14. FINISHING

14.1. General

Before focusing on cleaner technology methods it is useful to recall the main features of leather finishing since nearly each of them calls for specific considerations.

The purpose of finishing is to lend to leather some kind of grain protection against soiling and water but also the desired appearance, flexibility, colour, gloss or dullness and handle. Furthermore, depending on the end use, the finish has to meet some specific performance characteristics regarding dry and wet fastness, water vapour and perspiration permeability and high resistance to staining by water droplets.

To achieve that aim leather is subject to a series of processes and operations with many variations adapted to raw material, requirements by individual customers while also taking into account environmental, occupational safety and health (OSH) aspects and even weather conditions.

A good example of high performance leather requiring superior finishing is automotive leather. The interior temperatures in the vehicle can vary widely; the leather needs to be able to withstand not only considerable wear and tear but also intense sunlight with very low emissions (fogging).

14.1.1. Typical mechanical operations

A very wide range of mechanical operations in very different and varying sequences can be carried out to hide (natural) defects, improve the appearance and lend the desired feel of the leather. The commonly used mechanical operations in the finishing department are:

- conditioning (optimising the moisture content in leather for subsequent operations)
- staking (softening and stretching of leather)
- dry milling
- polishing
- plating (flattening)

Some of these operations (e.g. staking) may be carried out in both the wet and dry finishing departments, before and/or after applying a coat, or between the applications of coatings.

Figure 59. Vibro-staking machine



Source: Bobo Machines

To achieve specific grain appearance/effects or to hide grain defects, additional operations are needed:

- buffing of the leather surface followed by dedusting
- embossing (a pattern onto leather surface)

Figure 60. Schematic cross-section view of the buffing and dedusting machine

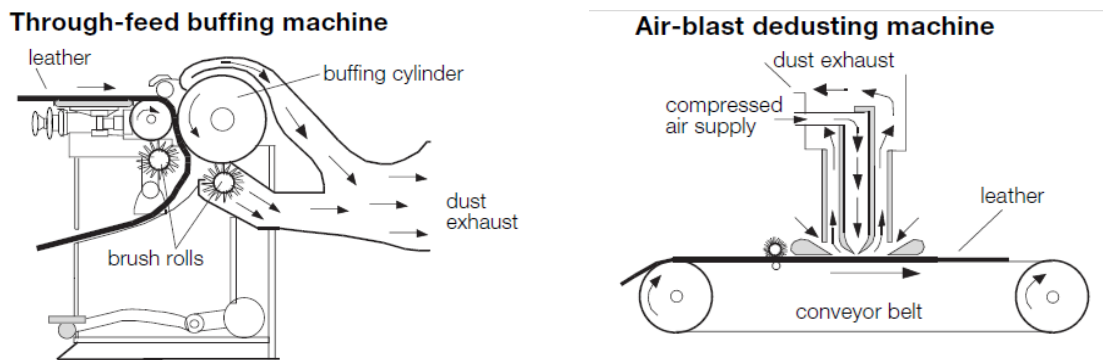

Source: BASF Handbook

Figure 61. Buffing and dedusting machine



Source: Rizzi-Flamar

Drying, usually in a tunnel with steam, gas or electric (infrared) heating is obligatory regardless of the method of application of finishes.

14.1.2. Typical coating stages – layers

Impregnation: To ensure good adhesion of coating layers, grain smoothness and tightness of the grain. It can be preceded by spray staining (e.g. to level drum dyed shades).

Base coat: Responsible for the general appearance and levelness and uniform distribution of pigment(s).

Top coat: Crucial for final appearance (e.g. gloss/dullness, feel), handle, and, in particular, wet and dry rub fastness of the finish.

Intermediate coats are often applied to improve the adhesiveness and compactness of the coating.

14.1.3. Coatings according to the character of grain

<i>Aniline finish:</i>	Transparent coats with no pigments except, if needed, very light levelling with aniline dyestuff (spray staining, the depth of penetration regulated by addition of organic solvent or penetrators). Natural appearance of the grain.
<i>Semianiline:</i>	Small amount of pigments in the base coat but not in the transparent top coat where some dyes can be used
<i>Corrected grain:</i>	The grain with defects (scratches, spots, scars, etc.) snuffed off by buffing, covering finish with heavier coats and pigments, embossed (patterns, grain imitation)
<i>Others, effects:</i>	Brush-off finish (two-tone effect produced by polishing/partial removal of the top layer); antique (two-tone imitation of old leathers); cracked effect, etc.

Other classifications of coating according to effect/appearance (e.g. pull up) or application technique (e.g. foam, film transfer finish), etc. are also possible.

14.1.4. Coatings according to the type of the main finishing materials:

<i>Casein finish:</i>	For elegant glazed finishing (e.g. chevreaux) based on non-thermoplastic protein or protein-like binders.
<i>Nitrocellulose:</i>	Nitrocellulose solution in organic solvent or (water dilutable) emulsion lacquers; alternatively solvent lacquer based on cellulose aceto-butyrate.
<i>Patent finish:</i>	A specific high gloss finish based on a very thick nowadays polyurethane finish
<i>Binder finish:</i>	The most widely used. The thermoplastic binders are based on polyacrylate, polybutadiene or polyurethane polymers.

One somewhat arbitrary, approximate scale of “eco-friendliness” according to the categories of finish coats:

Natural aniline → *semi-aniline* → *nubuck/suede* → *full grain “eco” finish* → *full grain conventional finish* → *corrected grain* → *coated splits*

The basic components of leather finishes are binders, colouring agents (pigments and dyes), carriers (solvents), cross-linking agents, auxiliaries and lacquers.

14.1.5. Binders

They bind pigment and other materials together; due to their adhesive properties they ensure good adherence of the film to the leather, too.

Protein binders generally consist of preparations based on albumen and casein with some additives like waxes and shellac. Protein binders use plasticisers, such as sulphated castor oil or polyethylene glycol.

However, the most commonly used binders are resin emulsions on the basis of poly-acrylics, poly-methacrylic esters, butadienes, polyurethanes, and vinyl acetates. Resins are water-based emulsions.

Polymer films are formed by drying dissolved or dispersed polymers. The presence of organic solvents, especially such as N-Methylpyrrolidone, NMP is not desirable.

14.1.6. Colouring agents

Dyes (usually pre-metallised dyes for spray staining or specific applications) are normally supplied in liquid form. Pigments, organic and inorganic, are much more widely used (iron oxides, titanium dioxide and carbon black). The use of inorganic pigments containing lead and chromate is harmful and prohibited.

14.1.7. Cross-linking agents

These are used to bind together joint polymer chains in the finishing material. They can be polyisocyanates and carbodiimides (for both base- and top-coats), applied for polyurethane finishes, epoxies (top-coats only) and metal oxides (butadiene finishes for splits). Ideally, cross-linkers should be VOC-free.

While their acute toxicity is rather low, isocyanates¹⁸ are potentially dangerous irritants to the eyes and respiratory tract; it is also believed that they might contain carcinogenic components.¹⁹

Highly toxic aziridines have been replaced by polyaziridines which are less toxic and can be used for base-coats and top-coats. Formaldehyde, traditionally used for casein finishes has been abandoned (carcinogenic). Ethyleneimine-based cross-linking agents used for top-finishes are also not acceptable (toxic and carcinogenic).

14.1.8. Lacquers and lacquers emulsions

These are used for the top or to fix the coat of a finish. They are made by dissolving nitrocellulose in solvents (e.g. ethyl acetate, methoxypropanol, methyl isobutyl ketone) subsequently emulsified with water and surfactant to give lacquer emulsions. Polyurethane lacquers are also used.

Auxiliaries

A very wide range of agents is used for specific purposes such as better film forming or better dispersion of pigments, improved penetration, thickening, dulling, fixing or sticking prevention. They can contain waxes, plant mucilages, phthalate-free plasticisers, cellulose products or polymers as protective colloids or natural or synthetic oils as softening agents.

Carriers

Carriers is another name for water and organic solvents needed to make suspensions/dispersions of binders used in finish formulations. There are organic solvents which actually dissolve the binders (e.g. ethyl acetate) and diluents, i.e. those that enable

¹⁸ Isocyanate: R-N=C=O; Carbodiimide: RN=C=NR

¹⁹ See, for example <https://www.osha.gov/SLTC/isocyanates/>

the ready-made solution to be diluted to spraying viscosity or the desired concentration (e.g. methoxypropanol, isopropanol).

Table 34. Solvents and diluents used in finishing (aqueous systems)

Solubilizers for aqueous systems						
Product	Abbreviation	Boiling range °C	Flash point °C	Ignition temperature °C	Density at 20/4 °C g/cm ²	Risk class
1-Methoxypropanol-2*	PM	119-122	32	270	0.962	A II
Butylglycol (2-Butoxy ethanol) *	BG	168-172	67	230	0.8995- 0.902	A III
Butyldiglycol (2-(2-Butoxyethoxy)- ethanol) *	BDG	228-232	105	210	0.952- 0.956	-
Dipropylenglycol-methylether (tech.mixture) *	DPM	185-195	80	205	0.957	A III
Propylenecarbonate**	PC	240-243	123	455	1.204	-
N-Methylpyrrolidone dist.**	NMP	204	91	245	1.028	A III

Source: BASF Handbook

*Recommended as substitutes for Ethylglycol

**Potential substitutes for Dimethylformamide (DMF)

Table 35. Solvents and diluents used in finishing (lacquers)

Solvents for lacquers						
Product	Abbreviation	Boiling range °C	Flash point °C	Ignition temperature °C	Density at 20/4 °C g/cm ²	Risk class
Ethyl acetate (Acetic acid ethylester)		74-78	-6	460	0.898- 0.902	A I
iso-Butylacetate (Acetic acid iso-butylester)	i-BuAc	115-118	19.5	425	0.866- 0.871	A II
n-Butylacetate ((Acetic acid n-butylester)	n-BuAc	124-128	26.5	415	0.880- 0.881	A II
2-Ethyl-hexylacetate		192-205	77	270	0.870- 0.875	A III
Butylglycolacetate		185-188	76	300	0.940	A III

Source: BASF Handbook

These products can be used instead of toluene or xylene as solvents for lacquers.

Although the solvents listed in the tables are less hazardous than previously used solvents, necessary precautions when handling organic solvents must be observed.

Quantities of surface coat materials applied range from only a few grams per square metre to 400 g/m² for corrected grain, pigmented splits and oily leathers.

Application of the surface coat

- Padding (manually or by machine)
- Curtain coating
- Roller coating (forward and reverse)
- Spray coating - manual and (usually) by rotary spraying machine;

Figure 62. Operating principle of compressed air spraying machine and spraygun

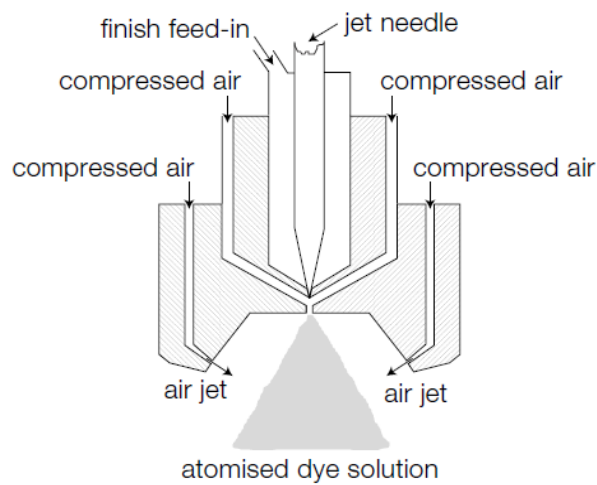

Source: BASF Handbook

Figure 63. A head of the rotary spraying machine



Source: www.carlessi.it

All of these finish applications are followed by drying.

Table 36. Finishing products – Approximate amounts required in grams/m² of leather

Products	Full grain leather			Corrected grain	Splits
	aniline	Semi aniline	pigmented		
Pigments	0-3	5-20	20-40	20-50	30-60
Aniline dyes	20-40	10-20	5-10	0-10	0-5
Binders	5-30	10-50	40-80	80-120	140-240
Auxiliaries	5-20	10-30	10-40	20-40	20-40
Top coating emulsions	20-60	20-60	20-60	30-60	30-60
Water-based top coats	20-60	20-60	20-60	30-60	30-60
Organic solvents	0-10	0-30	0-30	0-80	0-40
Total	70-223	75-270	115-320	180-420	250-505

Derived from BASF Handbook

14. 2. Pollution emissions and some mitigation measures

Conventional coating by spraying results in considerable losses of coating material. Measured in terms of key pollution parameters (COD, BOD, SS) and the amount of waste water discharged at the finishing stage, it is quite insignificant in comparison with the beamhouse and tanning department (See the diagram below).

Figure 64. The share of finishing in total emissions

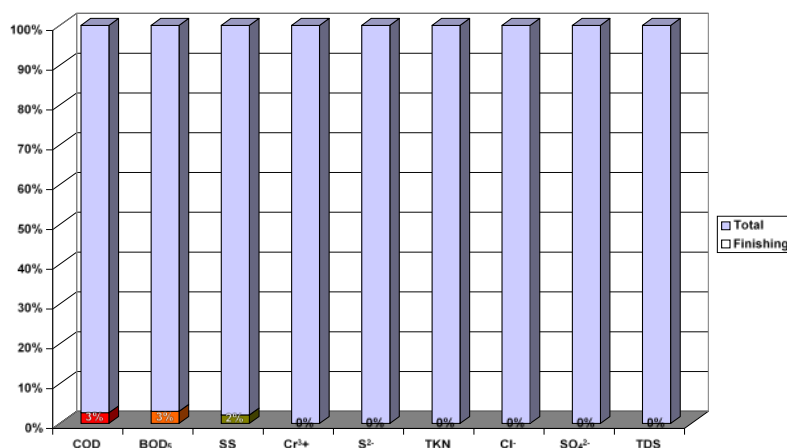

Chart by M. Bosnić

However, environmental threats due to use and emissions of pigments, organic solvents (VOCs), airborne particles and malodours in old poorly ventilated areas are quite serious; the negative impact of vibrations, dust and noise cannot be ignored either. All these risks compounded by high fire hazards make the old finishing departments possibly the most potentially harmful to workers' health.

Evidently, good housekeeping and monitoring finish usage, equipment optimisation (especially spraying), avoidance of re-work, etc. are also important in reducing the negative environmental impact of finishing operations.

14.2.1. Airborne particulate matter

While a certain amount results from milling (softening due to mechanical action in drums), the main emissions of airborne particles in finishing emanates from buffing where leather surface is abraded; the particles are wet or dry and with a high organic content. In addition to irritation of the respiratory tract, the health risk depends on the particle size and its chemical composition.

Buffing dust concentrations vary widely (0.1 to 30 mg/m³) depending on the space and equipment in place. An efficient extraction ventilation system fitted with bag filters or wet scrubbers is a must; in the EU the efficiency norm to meet is 3 to 6 mg/Nm³ of exhausted air expressed as a 30-minute mean. It is also necessary to reduce the noise pollution from the exhaust system itself that can be considerable which is why its design, selection and positioning of fans is very important.

A disposal route for the dust collected is not easy to find; in some cases it is taken away, compacted and briquetted.

14.2.2. Solid waste and waste water

Solid wastes in finishing are mainly residues from finishing mixtures and sludges from air pollution abatement systems. Waste water comes from the finishing kitchen and equipment cleaning; while the volume of waste water is insignificant, the water can be heavily polluted by the presence of organic solvents, pigments containing some metals as well as hazardous chemicals present in other finishing materials such as cross-linkers and auxiliaries.

In some tanneries, particulate matter is compacted and briquetted after being collected by various systems. These residues are wastes for which a use or disposal route must be found. If a wet scrubbing system is used, the slurry produced is a waste for disposal. Recycling the washing water can reduce the water consumption.

14.2.3. Organic solvents - Volatile organic compounds (VOC)

As said earlier, organic solvents are used as carriers in the formulation of the finish. However, as a rule they are also already contained in commercial finishing products (e.g. lacquers) very often without indication about the type and quantity of organic solvent used.

The main problem with organic solvent-based coating agents is the emission of volatile organic compounds (VOCs) released during and after the coating process.

A number of organic compounds are directly harmful to human health or to the environment. Moreover, many organic solvents undergo chemical reactions in the atmosphere that cause a number of indirect effects, in particular the formation of photochemical oxidants and their main constituent, ozone. Pollution by tropospheric ozone is a widespread and chronic problem.

Due to their persistency and accumulation in the biosphere, halogenated hydrocarbons and, in particular, highly volatile halogenated hydrocarbons are subject to special attention and the relevant legislation.

Certain halogenated organic compounds are ozone-depleting substances and in compliance with the Montreal Protocol have to be phased-out.

Either the pure solvent is used or products like biocides and auxiliaries used in the finishing process may contain halogenated organic compounds.

Untreated organic solvent emissions from the finishing process can vary between 100 and 3500 mg per m³ in conventional processes. About 50% of measurable emissions arise from spray-finishing machines, 50% from dryers. Fugitive emissions to the air and solvents in wastes account for the rest of solvent consumption.

The storage and use of organic solvents require special measures to reduce releases into the air and avoid spillage onto the ground; it is not quite known, for example, whether or not chlorinated organic compounds can even easily pass through concrete floors. On the other hand, their substitution, i.e. non-halogenated compounds may require additional safety fire and explosion precautions.

There are considerable variations in the use of solvents not only for different types of leather but also between individual producers.

The release of VOCs requires special abatement techniques. Organic solvent-based processes in closed spray cabinets and closed drying systems, which offer an acceptable environmental performance, require cost-intensive abatement techniques.

Scrubbers create an effluent containing finish mixes and water-miscible organic solvents. Organic solvents that are not water-soluble will be emitted into the air. Equipment for wet scrubbing of the exhaust air has become a standard installation in most spraying units in order to eliminate dust particulate and aerosols.

In assessing the VOC emissions, a distinction has to be made between the applied solvents according to their toxicity.

The spray booth must be closed during processing in order to minimise emissions from the over-spray (aerosols, organic solvents) into the working environment. Extracted air requires treatment to reduce particulate and organic solvent emissions.

Table 37. Solvent emission limits for leather coating

Annex VII of Directive 2010/75/EU Activity No. 13	Annual solvent consumption in tonnes	ELV g of solvent emitted per m² of product produced
For leather-coating activities in furnishing and particular leather goods used as small consumer goods like bags, belts, wallets, etc.	> 10	150
Other coating of leather (medium use)	10 - 25	85
Other coating of leather (high use)	> 25	75

Source: BREF 2013

The leather industry as a whole has considerably reduced its solvent use. For example, in some parts of Europe the consumption of organic solvents in finishing in the last 15 years has more than halved.

Table 38. Comparison of VOC emissions from different types of finishes

Coating material	Organic solvent	Emission (kg/h)	Emission concentration (g/m³)
Solvent-based finish	> 75 %	50	3
Water-based finish	10 – 75 %	5	0.3
Solvent-free finish	< 10 %	< 1	

Source: BREF 2013

The VOC emission levels considered to be in conformity with Best Available Technologies (BAT) in the EU are given in the next Table.

Table 39. BAT-associated solvent use levels and BAT-associated emission levels for VOC

Parameter	Type of production		BAT-associated levels
			g/m ² (annual avg. values)
Solvent use levels	Where water-borne coatings are used in combination with an efficient application system	Upholstery and automotive leather	10 - 25
		Footwear, garment, and leather goods leathers	40 - 85
		Coated leathers (coating thickness > 0,15 mm)	115 - 150
VOC Emissions	Where an extraction ventilation and abatement system is used as an alternative to the use of water-borne finishing materials		9 - 23 (1)

(1) BAT-Associated Emission Levels (AEL) range expressed as total carbon

Source: BREF 2013

The main parameters for an assessment of organic solvent-based finishing agents are:

- the type of organic solvent used with regard to toxicity and the recycling options;
- the efficiency of abatement in all processes where organic solvents can be released consequently, i.e. also in drying and storage;
- the ratio of recycling or reuse of the organic solvent.

The minimum requirement for organic solvent-based coatings is the recording of solvent consumption, to include not only the solvents bought as solvents but also the solvents contained in the finishing chemicals. This is the only acceptable way to calculate the overall emissions of VOC, because it is not possible in practice to monitor fugitive emissions. VOC releases from leather during storage are estimated as 10% of the applied organic solvents that remain in the leather and about 60% of the amount emitted in the drying tunnel. The rest is emitted during storage. Ideally, VOC free finishing systems should be based on renewable resources.

Reducing organic solvents – VOC emissions is in principle possible in the following ways:

- Full replacement of organic solvents based with water-borne coatings (e.g. by replacing lacquers with hard resin topcoats)
- Partial replacement (e.g. replacing lacquers with lacquer emulsions)
- Use of advanced extraction ventilation and abatement systems (wet scrubbing, adsorption, bio-filtration and/or incineration)
- Combination of the above methods with particular attention to the coating techniques themselves

Completely organic solvent-free finishing is still not available; however, while the organic solvent content in organic solvent thinnable lacquer is 80-90%, in water thinnable lacquer emulsions is about 40%, in water-based systems it is only 5-8%. Provisions for organic solvent recycling include a careful selection of organic solvents; otherwise recycling can be impossible.

Furthermore, for cleaner finishing selection and application of X-linkers careful consideration and control are needed; similarly, to the extent possible water-based spray dyes should be used.

Figure 65. Hydraulic plating and embossing press



Source: Mostardini

14.3. Pollution prevention and/or reducing measures

Water based finishing

In water based finishing, finishing products are dispersed in water rather than in organic solvent.

In the finishing process, water-based systems are increasingly favoured because of environmental concerns about organic solvents and in order to comply with regulations. For applying the coating layers, different techniques can be used.

In order to achieve equal characteristics with low organic solvent and water-based systems, cross-linking agents for the finishing polymers often have to be used. The toxicity of these agents is problematic, but commercial products offer the agents in a less toxic and less volatile form. Nevertheless, appropriate safety precautions are required when handling and applying these agents.

For any organic solvent applied in the process that cannot be substituted by aqueous systems, the alternative is to use organic solvents with the lowest impact on workplace

safety and the environment and, in order to make recycling feasible, to avoid mixtures.

The main advantage of water-soluble lacquers is the considerable reduction of organic solvent consumption and releases. Most water-based finishing products still contain a low amount of organic solvents. The suitability of water-based coatings is still dependent on the final product that is produced. The coatings are being improved, and the range of uses is being expanded.

It should not be overlooked that the **energy consumption for drying water-based top-coats is higher**. Yet, solvent-based finishing is higher in CF than water-based finishing.²⁰

There may also be an increase in the organic content of waste water from finishing.

Base coats are generally water-based. If very high standards of top-coat resistance to wet-rubbing, wet-flexing and perspiration are required, then solvent-based systems cannot always be substituted by aqueous-based systems.

In general, solvent-based and water-based systems have similar costs.

14.3.1. Improved coating techniques

Padding, curtain coating, roller coating, and spraying of leather are substantially different coating techniques suited to different types of leather articles produced and coating materials applied.

14.3.2. High-volume low-pressure (HVLP) spray guns

High-volume low-pressure spray guns spray with a large volume of air at low pressure so that the “bounce-back” is considerably reduced in comparison with conventional spraying. The HVLP technique does not give completely satisfactory results for some articles, such as upper leather and garment leather.

The air column from the conventional spraying gun (pressure about 2.0 bar) carrying finishing articles bounces back from the leather surface resulting in a loss of 55-65% of finishing material.

High volume, low pressure (only about 0.7 bar) HVLP spray guns compensate high pressure by larger air volume thus reducing the bounce-back effect and the resulting finish losses.

²⁰ *Reducing the carbon footprint of leather, B. Wegner, World Leather Dec 2014*

Table 40. Comparison of conventional and HVLP spray guns

	Advantages	Disadvantages
Conventional	<ul style="list-style-type: none"> • No special pipework needed • Cheaper than HVLP 	<ul style="list-style-type: none"> • Poor transfer efficiency (40-60%) • Considerable risk of high emissions from the extraction system • Rapid build-up of solids in the spray cabin and transport lines
HVLP	<ul style="list-style-type: none"> • Material wastage less than 30% • Reduced emissions/pollution • Shorter cleaning times 	<ul style="list-style-type: none"> • More expensive • Air supply lines have to be changed • Fan stability quite sensitive

14.3.3. Airless spray guns

The coating material itself is pressurised. It is then atomised at a spray nozzle without the use of air. Airless spraying is more suited for high application rates.

HVLP and airless spraying improve spraying efficiency up to 75%, compared to spraying efficiency as low as 30 % for conventional spraying operations. HVLP or airless spraying may not be suitable for all coating materials. This situation is likely to change as low solvent coatings are improved.

14.3.4. Computer-aided spraying

Computer-aided spraying means that automated systems sense the area, either by a mechanical feeler, electric eye or ultrasonic system and control the opening of the guns so that they only spray when the leather is passing directly beneath them. The technique is widely available in more or less sophisticated versions. Care must be taken that the detection equipment is properly adjusted.

Computer-aided spraying can prevent up to 75% of the finish being lost as overspray. The emissions of spray mists are reduced, and because coating efficiency is improved, solvent emissions are reduced too.

Existing equipment can be retrofitted for HVLP, airless and computer-aided spraying, but the costs and effort involved will depend on the type of systems already in place.

Proper design and operation of spraying exhaust is important for reducing pollution and fire risks.

14.3.5. Curtain coating

It can be compared to roller coating, but cannot be used as a substitute for spray coating. This technique may be used to apply finishes which have a high organic-solvent content.

Figure 66. Operating principle of the curtain coater

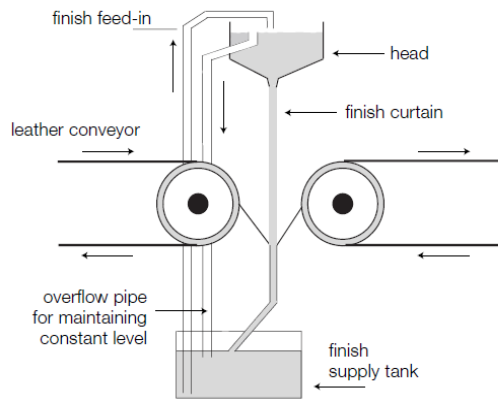

Source: BASF Handbook

14.3.6. Roller coating

The finish is applied by grit rollers to the surface of the leather, similar to the process used in printing. Differences exist concerning the grit size of the roller, the direction of application and the speed of the conveyor and the rollers.

This process is used especially, but not exclusively, to treat large pieces of leather, but the stability, softness, and thickness of the leather are important parameters. The operation needs careful adjustment with respect to speed, viscosity, and the cleaning of rollers to produce the desired quality. It might not be applicable to very thin leathers.

Figure 67. Operating principle of the roller coater

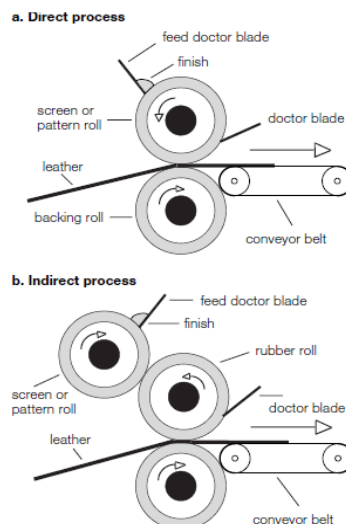

Source: BASF Handbook

Roller coating techniques are nowadays well established but further research and developments are ongoing. More specialist models allowing for hot and cold applications of oils, waxes and microfoam products are also available on the market and are used in several tanneries in Europe. The same conveyor/drying unit as for the spraying booth can be used.

Forward coating is suitable for lighter top and contrast coats (typically 1-5g/sqft); reverse coating for heavier impregnation and base coats (3-30g/sqft).

The more efficient application of coating materials leads to less waste and less solvent emission for the coating of a given area, to the benefit of the environment. Avoidance of the mist and solid particulate emissions associated with spraying is also beneficial.

The coating material itself is pressurised. It is then atomised at a spray nozzle without the use of air. Airless spraying is more suited for high application rates.

Figure 68. Reverse and forward roller coaters: schematic view

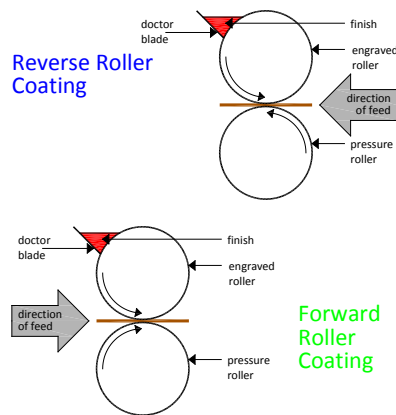

Source: BASF Handbook

The operational data will entirely depend on the product that is being produced. Coating wastage rates of 3 – 5% are reported as opposed to 40% for conventional spraying.

Figure 69. Roller coater



Source: Gemata, World Leather, Dec 2014

This technique is not as flexible as spraying and can be applied only for the production of leathers with a coated grain, not for aniline, aniline-type or semi-aniline leathers.

Figure 70. Ironing machine, adjustable pressure

Source: Bergi, World Leather Dec/2014

Table 41. Overview of leather coating methods

	Advantages	Disadvantages
Padding	<ul style="list-style-type: none"> • Good adhesion • Compensation of uneven wetting 	<ul style="list-style-type: none"> • Labour intensive • Not good for top coats • Additional spray coats needed • Machine padding not quite satisfactory
Spraying	<ul style="list-style-type: none"> • Uniform application • Wide range of applications • High output • Possible various angle spraying effects • Easy to make minor colour adjustments 	<ul style="list-style-type: none"> • High percentage of material wastage (40-60% normal, 25% with HVLP guns) • Sometimes adhesion and intercoat problems • Air pollution • High energy consumption
Curtain coating	<ul style="list-style-type: none"> • Suitable for impregnations corrected grain • Waste is only about 10% • Lowest investment 	<ul style="list-style-type: none"> • Not suitable for grain/quality leathers • Rather low output

	Advantages	Disadvantages
Roller coating	<ul style="list-style-type: none"> • Better adhesion than with spray coating • Suitable for large hides, hot applications of oils and microfoam finishes • Possible wide variations in amount of material applied (1- 30g/sqft) • Waste is only about 10% • Higher solids, the same dryer but less energy for drying • Environmentally friendly 	<ul style="list-style-type: none"> • Viscosity adjustment required • Thin areas missed • Pleating of soft leathers • Turkey tracks due to system imbalance • Lower output in comparison with spray coating

Recycling of the cleaned air might save energy for workplace heating.

Attempts with through-feed and water transfer systems finishing via coat paper have not gained much ground.

Figure 71. Low cost drying in a developing country



15. RESTRICTED SUBSTANCES

15.1. General

Restricted substances are chemical substances controlled by national or regional legislation, (multinational) brands and/or ecolabel due to their proven negative impact on human health (of both workers and consumers) and eco-systems.

The normal transfer routes of such substances are by absorption through skin, inhalation or ingestion; although typically present in very small quantities, their impact can be significant.

Too often there is a lot of misunderstanding and unscientific interpretations of hazards associated with exposure to directly or potentially harmful substances. Too often is forgotten the gist of the statement by the medieval chemist Paracelsus: *Everything is cure everything is poison, it depends on dose* (and the transfer route). Even a perfectly innocent chemical like distilled water injected into our bloodstream in larger amounts can be fatal!

Below are some considerations that might be useful in that regard:

- ❖ The hazardous products **are not a priori harmful**; handled properly with adherence to the prescribed/recommended safety precautions, they are quite safe. In other words, the potential hazard and the real risk are not the same.
- ❖ The potential hazard posed by a certain chemical is a constant factor; it is the level of exposure (i.e. quantity/concentration, the transfer route, length of time, frequency, etc.) that determines the overall risk.
- ❖ In this context it is useful to understand the categories of Threshold Limit Value - Time Weighted Average (TLV-TWA₈) and the Short Term Exposure Limit (TLV-STEL).
- ❖ Of particular importance is the MAK value (maximal workplace concentration), i.e. the maximum allowable concentration in the workplace in the form of gas, vapour, or air-suspended matter which, according to our present state of knowledge, generally does not impair the health of the workers and does not inconvenience them unduly, not even on repeated and prolonged exposure for normally 8 hours daily under the condition of a weekly working time of up to 45 hours.
- ❖ It is also useful to understand the significance of measured or prescribed amounts of a substance such as D_{tox} (toxic dose), DE (efficient dose) DL/LD (lethal dose), ID (individual dose), IMD (individual maximum dose), MD (maximum dose), MDD (maximum daily dose), ND (normal dose), DD (daily dose), LD₁₀₀ (the absolutely lethal dose), LD₅₀ (the average lethal dose, at which 50% of animals in an experiment are killed) and LD₀ (the maximum non-lethal dose).
- ❖ Use of “greener” chemicals (e.g. biocides) is not necessarily better if they are weaker and higher amounts have to be applied.
- ❖ Here it is important to distinguish the risk of *acute toxicity* (poisoning produced by a single dose), *subchronical* (poisoning produced by toxicity of repeated dosage within a relatively short time) and *chronical* toxicity (poisoning produced by repeated dosage over a relatively long time).

- ❖ All chemicals have to be evaluated according to their acute oral toxicity, irritation to the skin and mucous membranes, mutagenic, teratogenic and carcinogenic effects and the effects of repeated or prolonged exposure.
- ❖ The worker in production (much less the ultimate user of leather product) can be protected from the actual or potential hazard posed by a chemical in various ways, for example by wearing personal protection equipment (gloves, goggles, mask) or by limiting the extent to which he is exposed to it.
- ❖ It is vital that all important data and risks are communicated to all involved in a readily understandable form. In addition to Safety Data Sheets this also includes symbols, drawings as well as warnings in the local language.
- ❖ Regrettably there are no widely accepted standardised analytical tests for all chemicals found on RSLs; in principle, all limits should be realistic and accurately measurable.

In the globalized world economy and certainly for any export oriented leather and/or leather products manufacturer, it is very prudent to go beyond national legislation and adhere to the strictest norms concerning the presence of some proven or potentially harmful substances.²¹

15.2. REACH

At the moment this is possibly the globally strictest legislation valid in the European Union (EU) widely known under its acronym REACH²² which stands for Registration, Evaluation, Authorisation and Restriction of Chemicals that entered into force on 1 June 2007. It is the leading chemicals management scheme – complex, sophisticated, expensive and bureaucratic, but it is likely to bring about much better information and control on potentially harmful substances than any system to date. Also, it can be safely assumed that the use of substances limited or banned under REACH is very likely to be similarly restricted under other national or international legislations. Thus, it is very useful to familiarize with and understand its main features.

- Its proclaimed aim is to ensure a high level of protection of human health and the environment as well as the free movement of substances, on their own, in preparations and in articles while enhancing competitiveness and innovation.
- Its key operational body for implementation is the European Chemicals Agency, ECHA.
- REACH terminology:
 - **substance** is a chemical element and its compounds in the natural state or obtained by any manufacturing process (including any additive, but excluding any separable solvent) whereas

²¹ *Of particular interest to tanners could be the Global Automotive Declarable Substance List (GADSL), http://www.americanchemistry.com/s_plastics/blank*

²² *According to ECHA, REACH is a regulation of the EU, adopted to improve the protection of human health and the environment from the risks that can be posed by chemicals, while enhancing the competitiveness of the EU chemicals industry. It also promotes alternative methods for the hazard assessment of substances in order to reduce the number of tests on animals.*
Source: <http://echa.europa.eu/en/regulations>

- **preparation** is a mixture or solution composed of two or more substances; leather is an “article” which does not intentionally release chemicals like a pen or an ink jet printer which means that leather *per se* is exempt from REACH registration
 - Tanneries fall into category of **downstream users (DU)** - unless they manufacture some substances by themselves. The same applies to leather footwear, apparel and leather goods companies. In turn, all of them, including tanneries, are producers of *articles*.
- Only registered *substances* and *preparations* (chemicals) i.e. only those which properties, including possible risks in application and use have been thoroughly investigated and made widely known, can be used in manufacture
 - Obligatory and extensive exchange of information along the entire supply line is essential
 - A particular emphasis is on monitoring, control and avoidance of substances considered *carcinogenic, mutagenic, toxic for reproduction, persistent, bioaccumulative and toxic or having endocrine disrupting properties*.²³

15.2.1. Restricted substances (Regulations, Annex XVII) of interest to tanners:

- Pentachlorophenol
- Cadmium and its compounds
- Short-chain chlorinated paraffin
- Cement and cement-containing preparations, if they contain, when hydrated, more than 0,0002% soluble chromium VI of the total dry weight of the cement.
- Nonylphenol
- Nonylphenol ethoxylate

15.2.2. Substances of very high concern, SVHC (Regulations, Annex XIII)

- Here are classified substances which are considered extremely harmful for being *carcinogenic, mutagenic, toxic for reproduction, persistent, bioaccumulative and toxic, very persistent and very bioaccumulative, as having endocrine disrupting properties or having a combination of the mentioned properties*.
- The list is expected to be expanded/updated with other substances for which there will be sufficient scientific evidence for falling into some of the listed categories.
- The threshold value for their content in articles is 0.1% weight weight (w.w).
- Towards the end of 2009 there were only 15 substances and 15 more being added in January 2010. Some believe that ultimately the list might include more than a thousand substances.

15.2.3. SVHCs requiring special authorisation (Regulations, Annex XIV)

Some substances must not be used without specific authorization as they are classified as toxic to reproduction, carcinogenic and/or persistent, bioaccumulative and toxic (*PBT*) or very persistent and very bioaccumulative (*vPvB*)

²³ The EC/ECHA SVHC Roadmap to 2020 speaks of 1. CMRs (carcinogenic, mutagenic or toxic for reproduction) 2. PBTs (Persistent, bioaccumulative or toxic for environment) 3. vPvBs (very persistent and very bioaccumulative) and 4. Substances of equivalent concern (such as endocrine disruptors, respiratory and dermal sensitizers)

Tanners as well as also footwear, apparel and leather goods manufacturers should make sure that their suppliers are aware of REACH and comply with its requirements.

- Tanners' main obligations are to:
- Follow the instructions in the Safety Data Sheets
- Contact the suppliers if you have new information on the hazard of the substance or preparation
- Provide your customers with information if the content of certain very dangerous substances, which are candidates for authorisation, exceeds a concentration of 0.1 %w/w in the articles you produce.

Follow the ECHA Candidate List of substances of very high concern for authorisation.

Some of the 161 substances on the SVHC Candidate List for authorisation as of 17 December 2014:

Cadmium, o-Toluidine, 4-Nonylphenol, Arsenic acid, Calcium arsenate, Phenolphthalein, Dichromium tris(chromate), Chromium trioxide, Sodium chromate, Ammonium dichromate, Potassium chromate, Boric acid, Trichloroethylene, Potassium dichromate, 4-Dinitrotoluene, Dibutyl phthalate (DBP), Sodium dichromate, Alkanes, C10-13, chloro (Short Chain Chlorinated Paraffins)

15.3. Practical considerations

The chemicals included in nearly all lists of restricted substances (RSL, MRSL) are:

15.3.1. Hexavalent chromium (chromium VI)

Carcinogenic if inhaled. As it has no tanning effect at all, it is not used in tanning but present in low quality chrome powders. A synergistic effect of some factors can support oxidation of chrome III to chrome VI during manufacturing process and subsequently during transportation and storage of leather and leather articles:

- Certain conditions during wet-finishing (neutralisation)
- Drying, especially at higher temperatures for a prolonged time
- Presence of fatty acids in the fatliquors may have an especially important influence as unsaturated fats may promote chromium oxidation²⁴ and generation of VOCs.

²⁴ *The mechanism seems to be very complex. Some researchers suggest that highly reactive free radicals initiate the primary oxidation of unsaturated fatty acids and cleavage of double bonds resulting in a lipid radical (L) which reacts with atmosphere oxygen to form a peroxy radical (LOO) which in turn reacts with another fatty molecule to form a lipid hydroperoxide molecule and which, in the course of secondary oxidisation, breaks down to form an alkoxy radical (LO) and hydroxyl radical, the so-called heavy metals acting as catalysts or starters. However, the ultimate products of the reaction, VOCs (alcohols, ketones, and aldehydes) gradually reduce CrVI formed earlier back to CrIII.*

The risk of formation of chrome VI can be virtually eliminated by applying the following measures:

- For the neutralisation of wet blue leathers, use a reducing auxiliary agent
- Similarly, replace ammonia as a wetting back agent for crust leather
- Obligatory use of at least small amount of a vegetable agent (preferably tara, up to 4%) in retanning
- Avoidance of fatliquors containing unsaturated fatty acids (either free or esterified)
- The use of fatliquors with antioxidants
- Degreasing skins with a high content of natural grease (sheep and pig skins) before tanning.

The limit in leather and leather articles is 3ppm.

The analysis on presence of CrVI in leather is very sensitive; moreover, it has been argued that the official ISO/IUC 18 analysis systematically gives false-positives because the method itself is a source of a small amount of CrVI.

Contrary to some perceptions and in accordance with current EU legislation (Annex X, the Water Framework Directive 2000/60/EC amended in 2008), neither chrome III nor tannery wastes containing chrome III are included in the European Hazardous Waste List.

15.3.2. Formaldehyde

Carcinogenic. Traditionally mainly used as crosslinking agent in finishing but also as a tanning agent. Present in some retanning agents/synthans. There are various methods to keep the free formaldehyde within acceptable limits. One rather recent method proposes use of 2% of *Origanum onites* essential oil in fatliquoring to prevent release of free formaldehyde from tetrakis (hydroxymethyl) phosphonium salts and various synthan products.

The limits vary considerably; it is safe to keep it below 20 ppm.

15.3.3. Azo-dyes

Certain azo dyestuffs have the potential of cleavage into hazardous (carcinogenic) aromatic amines, especially in prolonged contact with skin; such dyestuffs are actually not manufactured by reputable suppliers anymore. The limit in all of the EU is 30 ppm.

15.3.4. Nonylphenol and nonylphenol ethoxylates (NPE)

Surfactants (non-ionic, anionic, cationic, or amphoteric) are mainly used as emulsifiers but sometimes also serve as anti-electrostatic, slipping and water-repellent agents.

The use of nonylphenol and nonylphenol ethoxylates (NPE) based surfactants is now being restricted and/or entirely banned; they are replaced by aliphatic polyethoxylates that do not break down to phenols.

15.3.5. Volatile organic carbon, VOC – organic solvents

These are volatile components of chemicals mainly used in finishing such as toluene and trichlorobenzene. Of primary concern is workers' exposure.

The pertinent legislations and/or norms are quite complicated and vary a lot. That is why it is essential to closely follow the latest developments on the global scale; also, it is prudent to adopt the lowest, i.e. the strictest limits. Similarly, chemicals should be obtained from reliable suppliers with proven record of adherence to the highest safety standards.

More recently a new HS-SPME-GC-MS method applying solid phase micro extraction (SPME) on-site procedure is claimed to be appropriate for detection and identification of VOCs emitted by leather and for simple and rapid determination of the qualitative and semi-quantitative composition of organic compounds in the sample.

Note:

Europe classifies organic compounds as VOC if their vapour pressure at 20⁰C or at application temperature is more than 0.1 hPa.²⁵

In the USA VOC are classified as chemical compounds that take part in photochemical reaction in the atmosphere.²⁶

15.3.6. Halogenated organic compounds present in various agents/auxiliaries

- **Fatliquors** containing more than 1% of chlorinated alkanes of chain length C10 -C13 are banned in the EU (REACH Annex XVII). They can be replaced by fatliquoring polymers based on methacrylates or (modified) silicone oils; for the time being there is still no adequate replacement for long-chain chlorinated alkanes required for special leathers.
- **In water- soil- and oil-repellent agents**
Like fatliquors, these agents can also contain organic solvents and organic halogenated compounds and they should be abandoned and replaced. When a complete substitution is not possible, optimised fluorocarbon resins in combined finishes for water-, soil- and oil-repellent leather can reduce the release of halogenated organic compounds.

To meet very high performance requirements expected from combined water-, soil- and oil-repellent leather finishes, aqueous fluorocarbon resins containing up to 30% of active polymer compound with 20 – 50 % fluorine in the polymer are still used. However, there is a wide range of products (paraffin formulations, polysiloxanes, modified melamine resins, polyurethanes) that could be used if only water repellence is required.

Considerable progress has been made in this area in avoiding perfluorooctane sulphonates (PFOS) and perfluorooctanoic acid (PFOA), potentially carcinogenic and banned by Stockholm Convention on Persistent Organic Pollutants, POPs and which are actually the undesirable by-products in production fluorocarbon resins. The recently introduced optimised fluorocarbon resins are not based on raw materials with a chain length of eight (C8) but with a chain length of four (C4) or six (C6); yet, further monitoring and control of releases into the environment are still needed.

²⁵ EC Directive 1999/13/EC

²⁶ CFR 40, Part 51.100(s) US EPA

In addition to elimination of such substances in the effluent, avoidance of halogenated agents also brings about a decrease of COD.

The EU 2006 limit for presence of PFOS is 0.005%; further restrictions cannot be excluded.

- **Inflame retardants**

Widely used brominated flame-retardants also fall into the category of POPs forbidden by the Stockholm Convention.

There are already ways and means to deal with this problem. Firstly, it is known that appropriate wet-end finishing (strong retanning with selected syntans and melamine resins, suitable fatliquoring) produces firm, more flame resistant leathers.

Ammonium bromide and inorganic phosphorus compounds (e.g. ammonium polyphosphate) can also lend the flame resistance of the satisfactory level for some end-uses. Silicon polymer products applied in finishing provide some fire resistance on quite a different principle: they burn leaving a residue of silica (SiO₂) and protecting the leather beneath.

Unfortunately, some high performance waterproof leather may still require the use of halogenated chemicals.

15.3.7. EDTA (ethylenediaminetetraacetate) and NTA (nitrilotri-acetate) - complexing agents

EDTA (ethylenediaminetetraacetate) and NTA (nitrilotri-acetate) are used as sequestering agents. Apart from affecting waste water treatment (EDTA can even "re-activate" some chrome contained in sludge), they also have an adverse impact on the environment especially in view of their poor degradability, EDTA in particular.

In dyeing and pretanning to wet white they can be replaced by polyphosphate-based and phosphonate-based products but not quite in wet finishing, mainly in avoidance of iron stains.

15.3.8. Pesticides

Many pesticides are classified as POPs. Pesticides are normally used neither in preservation nor in the course of leather manufacture; their presence is due to the application of pesticides to protect animals from ectoparasites. Many among pesticides are harmful and, to make it worse, some like synthetic pyrethroids and organophosphates are not destroyed throughout leather processing or even during effluent treatment. Some pesticides, such as 'drins' and lindane can be found in imported skins, while the arsenic is by now a real exception.

The use and presence of pesticides is regulated by national legislation. For example, the use of HCH, DDT and naphthalene is prohibited in Europe but they might end up in waste waters

of tanneries processing raw material from countries where legislation and/or enforcement are not so strict.

15.3.9. Biocides

The EU/ECHA Biocidal Product Regulation (BPR, Regulation (EU) 528/2012) defines that biocidal products are products used to protect humans, animals, materials or articles against harmful organisms, like pests or bacteria, by the action of the active substances contained in the biocidal product.

In leather processing biocides can be used at several stages, actually from preservation of raw hides and skins, soaking, pickling to tanning and wet finishing; they are also present in some chemicals used in liquid forms such as dyes, fatliquors and casein finishes.

Since they are developed to destroy certain life forms (microorganisms), there is no perfectly innocent fungicide, all biocides are potentially toxic; there is always some risk.

In broad terms, the biocides used in tanneries fall into two main categories: **bactericides** (predominantly used in raw material preservation and soaking) **and fungicides** (mainly from pickling to drying, typically for suppression of mould growth on wet blue and wet white hides and skins but also on finished leather during storage and transport in humid conditions).

Some commonly used bactericides are:

- Sodium dimethyldithiocarbamate
- Didecyldimethylammonium chloride
- N-hydroxymethyl-N-methyldithiocarbamate
- Tetrahydro-3,5-dimethyl-2H-1,3,5-thiadiazine-2-thione
- 2-Thiocyanomethylthiobenzothiazole (TCMTB).

These materials are added at rates of between 0.02 and 0.1% by weight. In the course of leather processing their concentration is rapidly decreased and the residues destroyed in the reducing conditions of combined tannery effluents before treatment.

Some commonly used fungicides are:

- o-phenylphenol (OPP)
- p-chloro-m-cresole (CMK)*
- n-octylisothiazolinone (OIT)
- thiocyanomethylthiobenzothiazole (TCMTB)

* *belongs to the category of organic halogen compounds*

The widely used pentachlorophenol, PCP was banned long ago due to harmfulness and persistence in the environment, its use discontinued; the limit was 5 ppm. A mould inhibitor DMF (dimethyl fumarate) is banned in the EU; buyers of leather upholstered furniture check fungicide levels.

In practice the choice of approved biocides is very limited and the pertaining legislation is likely to become even more restrictive, especially in the EU. The main reasons are the growing concerns about the effects of biocides on aquatic environment because some of them (notably organochlorine compounds) can “survive” the usual treatment of tannery waste waters.

For better effect some commercial products are actually mixtures of different active ingredients.²⁷ The amounts applied vary considerably: e.g. OIT 80 mg/kg, CMK or OPP not less than 580/280 mg/kg for wet blue and considerably more for wet white.

Biocides in the EU are subject to special regulation, the latest introduced on 1 September 2013²⁸.

15.3.10. Heavy metals

Apart from chromium in this (scientifically not clearly defined, ambiguous) category of main concern are *cadmium, lead, mercury, antimony and arsenic*. Cadmium, for example, is often used in finishing pigments (orange, yellow, red, green); it is believed to be carcinogenic, the limit being 75-100 ppm.

Arsenic, very rare but still found as a biocide used in raw hide/skins preservation is both toxic and carcinogenic.

²⁷ For example Preventol U-Tec G from Lanxess is a mixture of *o*-phenylphenol (OPP, 2-hydroxybiphenyl), *p*-chloro-*m*-cresol (PCMC) and octylisothiazolinone (OIT)
Source: <http://lanxess.com/en/corporate/media/press-releases/2013-00058e/5/>

²⁸ From 1 September 2015, a biocidal product consisting of, containing, or generating a relevant substance, cannot be placed on the EU market if the substance supplier or product supplier is not included in the Article 95 list for the product type(s) to which the product belongs. Source: <http://echa.europa.eu/en/biocides-2015>

16. SOLID WASTE

Note: It is expected that in the near future UNIDO will prepare a detailed study specifically dealing with solid wastes in the tanning industry.

16.1. Sources, quantities

Since only about 50-55% of corium collagen actually ends up as finished leather it is not surprising that a tannery generates large amounts of solid wastes. As a matter of fact, utilization and/or disposal of solid waste is nowadays one of the most difficult challenges especially in countries with stricter legislation and enforcement pertaining to waste handling; moreover, it is very likely that the pressures will escalate further.

Depending on the emission point and waste properties, local legislation and availability of facilities for treatment and utilization (read: market!), solid wastes can be categorized as tradable by-products, non-hazardous waste or hazardous waste. Whatever the case, the best practices for waste management should be adhered to in the widely known order of priority:

- ✓ prevention
- ✓ reduction
- ✓ re-use / recycling / recovery
- ✓ disposal

In the technical literature the figures about the amount of solid waste differ widely and sometimes are not comparable at all. The reasons are:

- Considerable differences in the type of raw material processed, e.g. heavy, very fat from Europe, USA vs. light hides from developing countries
- differences in the tanning process
- substantial variations in water content in the waste

As an example, below are figures from processing (lighter) European hides:

1000kg of wet salted cattle hides, weight class about 25.6 kg per hide processed to shoe uppers following the conventional technology

Table 42. An example of the amounts of solid waste, light European hides, shoe uppers

Type of waste	Kg
Fleshings	300
Trimblings	100
Unusable chrome splits	107
Chrome shavings	99
Chrome off-cuts	20
Crust leather waste	5
Buffing dust	1
Finished leather trimblings	5
Total	637

Source: Mass balance, J. Buljan et al. UNIDO

There are also emissions of about 40 kg of organic solvents and sludge from waste water treatment (approx. 420 kg at 30% of dry substance).

The EU BREF 2013 input/output overview for the conventional process suggests the following figures²⁹:

Figure 72. Typical solid waste ranges according to EU BREF 2013

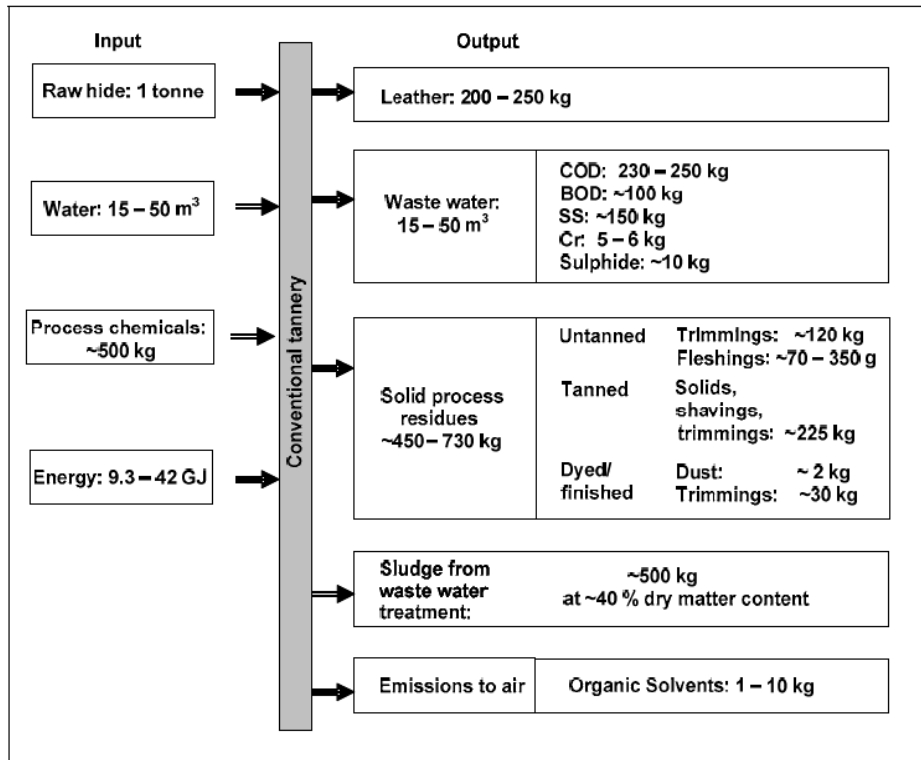

16.2. Waste management

16.2.1. Prevention/mitigation

The only component of raw hide ultimately converted into leather is corium collagen; other components are a “surplus” and have to be removed. Therefore, while the volume of solid waste *per se* cannot be reduced, there are ways and means to facilitate its handling:

- Increase the share of native and reduce the share of chemically treated solid wastes, especially those that are tanned; for example by green fleshing and lime splitting. Obviously this also significantly improves the uptake, and reduces both the consumption and discharge of chemicals.
- Reduce the amount of (non)usable waste by improving the efficiency and accuracy of some mechanical operations such as splitting and shaving or coating.
- Avoid unnecessary contamination of solid waste, thus leaving a wider range of options for their utilization.
- Good housekeeping implying very strict segregation and prompt handling of all categories of solid wastes
- Proper classification, segregation and handling of wastes not directly related to the tanning process: packaging material, barrels, paper, etc.

²⁹ The EU BREF 2013 input/output overview for an advanced tannery (including much higher share of by-products, i.e. usable solid wastes is not quite convincing).

16.2.2. Utilisation and safe disposal

In conformity with what was said earlier about their inherent properties, local legislation and availability of facilities for treatment, the scope for utilization of solid wastes varies a lot. A good, workable method and/or purpose in one country or region can be simply impractical elsewhere.

It is also necessary to emphasise that in papers presented in conferences or appearing in technical publications quite often are proposed solutions for utilization of solid wastes tested only at the bench scale and without any serious attempt to explore their commercial viability. Another aspect is that most of conversion methods to be commercially feasible require a considerable concentration of tanneries producing sizable quantities of solid waste. Tannery clusters – leather cities often offer such advantages of scale.

In any case, as a rule some of the wastes need to be treated on site before being sold or disposed of. Such treatments could include dewatering and/or drying and compacting.

Regrettably, it has to be admitted that for certain waste fractions, a landfill is still often the only option available.

A large amount of waste, in particular of organic waste, is inherent to production in tanneries. Both organic waste fractions and other residues can be prevented and reduced to a large extent by using Best Available Techniques (BAT) in the process units. Recycling options are numerous and can be carried out on site or off site. The potential for recycling should be exploited by ensuring segregation of waste. Of equal importance is commercialisation of wastes as by-products and co-operation between tanners to make recycling and re-use options economically feasible.

Source: UNIDO, D. Nemeč

The next table provides a simplified overview of re-use/recycling/recovery and/or disposal of individual waste fractions, partially based on EU BREF 2013.

Table 43. Overview of re-use/recycling/recovery and/or disposal of individual waste fractions

Type of waste	Contents	Further treatment/disposal/recycling
Raw hide trimmings	Collagen, hair, fat, connective tissue, blood	Production of hide glue Animal feed stuff Biogas Thermal treatment Landfill
Solid salt Brine	NaCl and possibly biocides	Reuse (problems with infectious material on salt) Landfill
Green fleshings	Fat, blood, meaty scraps	Production of hide glue Recovery of fat Composting Biogas Landfill

Type of waste	Contents	Further treatment/disposal/recycling
<i>Hair/wool</i>	Keratin-rich material	Wool is sold Reuse as filling material Production of lanolin from sheep wool Fertiliser/agriculture/animal feedstuff Composting Biogas Landfill
<i>Fleshings</i>	Fat, meaty scraps Liming and unhairing chemicals	Production of hide glue/gelatine protein hydrolysate Recovery of fat (fleshings only) Composting Biogas Landfill
<i>Lime split (flesh-side)</i>	Collagen plus liming and unhairing chemicals	Splits can be tanned to produce split leather Production of hide glue/gelatine Protein hydrolysate Sausage casings and other collagen products
<i>Tanned split</i>	Leather material of inconsistent thickness and no 'grain' surface	Split leather Leather fibreboard production Protein hydrolysate Composting Agriculture
<i>Shavings, Trimmings</i>	Organic matter with tanning chemicals	Leather fibreboard production Protein hydrolysate Composting Agriculture Thermal treatment Landfill
<i>Obsolete chemicals</i>	For chemical composition of agents	Disposal of chemicals according to their characteristics
<i>Particulate matter</i>	Organic matter with contents according to tanning	Landfill Thermal treatment Filler for plastics
<i>Residues from finishes, Sludges from finishing agents (over-spray, etc.)</i>	For chemical composition of agents Solvents Heavy metals	Landfill Thermal treatment
<i>Trimmings with or without finish</i>	Leather with contents according to tanning and finishing	Leather fibreboard production Other reuse: patchwork, small leather goods, etc. Landfill Thermal treatment

Type of waste	Contents	Further treatment/disposal/recycling
<i>Activated carbon, sludges from wet-scrubbers, filter dust, etc.</i>	Depending on the off-gas stream	Recovery of organic compounds (e.g. solvents) Thermal treatment Landfill
<i>Sludge from waste water treatment</i>	Depending on the separation of waste water streams	Use in agriculture Composting Biogas Landfill Thermal treatment
<i>Residues from on-site waste treatment</i>	Greaves from rendering, residues from anaerobic or aerobic digestion	Use in agriculture Landfill Thermal treatment
<i>Pallets, paper Plastics Containers for chemicals</i>		Recycling Landfill Thermal treatment
<i>Obsolete chemicals Scrap metal and defunct equipment</i>		Recycling Landfill Thermal treatment

Management and good housekeeping

Commitment of the tannery management is a prerequisite for good environmental performance. Technology by itself is not sufficient; it needs to go together with good housekeeping measures. A key to good performance is awareness of the inputs to and outputs of the process with regard to the characteristics of the materials, the quantities, and their potential environmental impacts. Criteria that ensure a better environmental performance can then be taken into account as well as technological criteria that focus on the properties of the end product. Furthermore, contamination should be kept at a bearable level with the reduction of spills, accidents, water wastage and chemical usage which can be achieved by the choice of appropriate techniques, good maintenance and operation control – by monitoring and adjusting process parameters – and good staff training.

Source: UNIDO, D. Nemeč

16.3. Conclusion

The only component of the raw hide required for and ultimately converted into leather is corium collagen; other components have to be removed. As a corollary, the volume of solid waste *per se* cannot be reduced.

With stricter regulations governing the utilization of by-products and disposal in landfills, costs in industrialized countries are expected to rise even further and this trend is likely to spread to developing countries too.

Thus, efforts need to be focused on:

- Increasing the share of native and reducing the share of chemically treated solid wastes, especially of those that are tanned
- Avoiding unnecessary contamination of solid waste and opening a wider range of options for their utilization
- Very strict segregation and prompt handling of all categories of solid wastes
- Proper classification, segregation and handling of wastes not directly related to the tanning process: packaging material, barrels, paper, etc.

Management of solid waste is presently one of the most difficult tasks in environmental management: a well-established reutilization and/or disposal method can almost overnight become unviable anymore either on account of changes in regulations or for commercial reasons.

As a rule, the picture of solid waste handling in a tannery well reflects the overall competence and commitment of the tannery management. Simply said, it is a true picture of the company.

Figure 73. Overview of the tanning operations and linkages

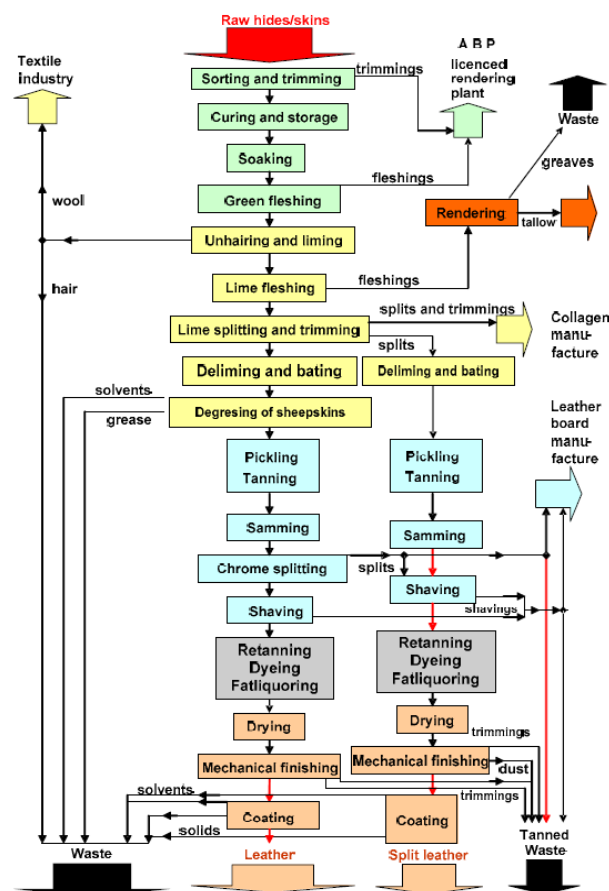

17. ENERGY CONSIDERATIONS IN LEATHER PROCESSING

17.1. General

Energy consumption in tanneries mainly depends on the following factors:

- production method, capacity, equipment
- performance of electric motors, controls sophistication level
- the ratio of manual vs. mechanical/automated handling (e.g. in moving the hides)
- tannery location – geographic zone, ambient temperature
- drying methods
- heat losses from process vessels and from buildings
- air exchange rates to meet workplace safety conditions
- type of waste water treatment on site
- types of waste treatment and recovery of energy from waste on site.

17.2. Energy consumption

The data in literature concerning the consumption of thermal and electric energy differ considerably, which is quite understandable because of significantly different conditions affecting the consumption. There are also wide variations in both methodologies in computing and the presentation of data. In practice, the figures on electricity and fuel consumption over longer periods and different seasons are the most reliable.

The category of the energy source is also very relevant - fossil fuel (natural gas, coal, Diesel), renewable (wood, biomass) or self-generated renewable (solar energy, wind).

It is important that comparisons between tanneries be made on the same basis. For example, 'effluent treatment' may or may not include biological treatment which can account for more than 50% of the energy consumption in the treatment of tannery effluent and also make a significant part of the tannery's total energy consumption.

Below are some selected data drawn from more recent publications.

17.2.1. The share of energy consumption for the main components in a European tannery

Table 44. The share of energy consumption for the main components in a European tannery

	Use	% of overall consumption
Energy type	Drying	33
	Hot water	33
	Space heating	19
Electric	Machinery and process vessels	10
	Compressed air	2.5
	Light	2.5

Source: Andres and Frendrup³⁰ (figures rounded up)

³⁰ Andres 1995, Frendrup 1999

The table gives an indication of energy consumption by type of energy input. The proportions can vary greatly between tanneries. For example, mechanical handling can be from largely manual to transfer by forklift trucks powered by internal combustion engines or by electric powered conveyors. Ideally, energy use should be monitored and reported separately for each process stage, and it is known that some of the most energy-efficient tanneries do so.

In such cases, comparisons of the energy inputs for the same stages and of the total energy input for the entire leather making process are more informative and reliable.

17.2.2. The LWG Protocol

In the LWG's document³¹ the reference figures on energy consumption, including waste water treatment (ETP) are conveniently given for processing stages e.g. from "raw to tanned" or "tanned hide to finished leather". While in the first case it is expressed in MJ/t of raw hides for all other stages the energy consumption is expressed in MJ/m² of produced leather, using the conversion factor of 160 m²/t of raw hides.

Not surprisingly, the energy consumption ranges are very wide: based on reference figures given it can be derived that, for example, for tanneries processing from raw hide to finished leather the energy consumption is 26.8 - 160.6 MJ/m² of finished leather or from 4288 - 25696 MJ/t of raw hides.

17.2.3. EU BREF 2013

The EU BREF 2013 indicates the following consumption to correspond to the Best Available Technology (BAT)

Table 45. Specific energy consumption associated with BAT

Activity stages	Specific energy consumption per unit of raw material (1)
	GJ/t
Processing bovine hides from raw to wet blue or wet white	< 3
Processing bovine hides from raw to finished leather	< 14
Processing sheep skins from raw to finished leather	< 6

(1) The energy consumption values (expressed as an annual average not corrected to primary energy) cover the energy use in the production process including electricity and the total heating for indoor spaces, but excluding the energy use for waste water treatment.

17.2.4. Eco-design³²

The estimation for the consumption of thermal energy for sheep skins tanning and the values derived from these data are given in Table 45.

³¹ LWG Environmental Protocol Audit Responses Report, Issue 6.0

³² Eco-Design: Life Cycle analyses show that energy is a key factor for the environmental impact of leather and might save money, T. Poncet et al. IULTCS Congress, 2011

Table 46. Estimates of energy consumption in a French sheep tannery

	KWh/m ²	MJ/m ²	MJ/t	%
Heating of the buildings	3.20	11.5	1840	33%
Dryers in the dyeing department	1.06	3.8	608	11%
Dryers in the finishing department	2.78	10	1600	28%
Hot water for the process	2.78	10	1600	28%
Total	9.8	35.3	5648	100 %

It is not clear, whether these data are calculated as the net thermal energy consumptions (not corrected to primary energy) or from the fuel used. Estimates of the consumption of electric energy are given in the next table.

Table 47. Estimates of the consumption of electric energy for various purposes in a French sheep tannery

Tannery steps	Electricity kWh/m ²	kWh/t	MJ/m ²	MJ/t	%
Main processes (pumps, motors, cooling systems)	0.99	158	3.6	576	45
Drums	0.34	54	1.22	197	16
Lighting	0.31	50	1.11	178	14
Ventilation and air heater	0.14	22	0.5	80	7
Compressed air	0.22	35	0.79	126	10
Finishing	0.12	19	0.43	67	6
Fleshing machines	0.03	5	0.11	18	1
Offices	0.01	2	0.04	6	1
Total	2.16	345	7.8	1248	100

Obviously the electric energy for the effluent treatment is not included. Also, the values for sheep skins tanneries are not directly comparable with those for bovine hides but nevertheless they are quite interesting.

The energy prices provided (0.081 EUR/ kWh for electric energy, and 0.054 EUR/ kWh for thermal energy) are comparably too low and do not seem realistic.

17.2.5. Energy savings in leather manufacture, G. Sykes, World Leather

In this article, the consumption of thermal energy, for the unknown process is estimated at 16800 cal/m² (70.3 kJ/m² of finished leather). In the same article the consumption of electric energy is estimated as 0.0748 kWh/kg of raw hide corresponding to 74.8 kWh/t of raw hide or 268 MJ/t of raw hides.

17.2.6. UNIDO paper on benchmarking³³

In the UNIDO study the consumption of the energy for the processing from raw hides to wet blue, including the effluent pretreatment, the figures are derived from data from a European tannery:

Steam (thermal energy)	1.42 GJ/t	Including heating cca. 25%
Electricity	104 kWh/t or 0.374 GJ/t	Including effluent pre-treatment
Total	1.794 GJ/t of raw hide	Moderate climate, long winters

³³ Benchmarking in the Tanning Industry, UNIDO

17.2.7. UNIDO paper/EU BREF 2003

Energy consumption in the company Elmo Calf AB processing from raw hide to finished product (automotive and furniture use) for the year 1999 provides the following values:

Annual production	11,700 t raw hides 2.4 million m ² finished products (automotive and furniture use)
Energy	11.3 GJ /t raw hide
<i>Electric energy</i>	3.0 GJ
<i>Thermal energy</i>	8.3 GJ

Source: BREF, February 2003.

17.2.8. Estimate of energy consumption for a virtual tannery of 10 t of w.s. hides/day (UNIDO)

Drawing on figures from the sources mentioned earlier and own computations, it is estimated that for a tannery processing 10 t of raw hides/day from raw to fully finished leather (shoe uppers), with the yield of 160 m²/t of raw hides (the same as applied in LWG document!³⁴), the order of magnitude of energy consumption would be as shown below:

Processing	GJ/t	kWh/t	MJ/m ²	GJ/d for a 10 t/d tannery	TJ/y for a 10 t/day tannery
Thermal energy	8.3	2306	52	83	30.3
Electric energy	3.0	833	18	30	11
Total energy	11.3	3139	70	113	41.3

Calculating with the calorific value of approx. 10 kWh/l = 36 MJ/l the amount of liquid fuel required to produce this amount of thermal energy is:

Processing	GJ/t	Liquid fuel l/t	Liquid fuel l/d	Liquid fuel l/y
Thermal energy	8.3	230	2300	84000

17.3. Energy losses, costs

There are many sources of losses of thermal energy:

- heat lost from hot surfaces (vessels, tubes) and from building
- the use of inadequate equipment (combustion equipment and boilers) for production of hot water necessary for the processing
- the use of inadequate equipment for drying

Heat losses may be mitigated by thermal insulation, but may be exacerbated by a low external temperature. High moisture content in the air may increase the energy consumed in drying.

³⁴ LWG Environmental Protocol Audit Responses Report, Issue 6.0

Energy use data from one climatic zone may not be an accurate guide to what may be achieved in another.

Modern combustion equipment and boilers (especially boilers which utilize the energy from the condensation of water steam from the fumes) can have the efficiency of above 90%. A larger central boiler may be more efficient, but if operations are dispersed on a large site, heat losses from pipework may eliminate the gains.

The cost for thermal energy can also be reduced by correct choice of the fuel, depending on its local accessibility and prices. The most practical way of reducing the cost of the thermal energy is the use of solar and/or ambient renewable energy.

17.4. Use of non-traditional and/or renewable energy sources

17.4.1. Solar energy

The furnishing of the sun energy depends firstly on location (climate zone). The next figure shows the yearly average furnishing of energy (insolation) in $\text{kWh/m}^2/\text{y}$ and $\text{kWh/m}^2/\text{d}$, related to geographic location.

Figure 74. The world insolation map

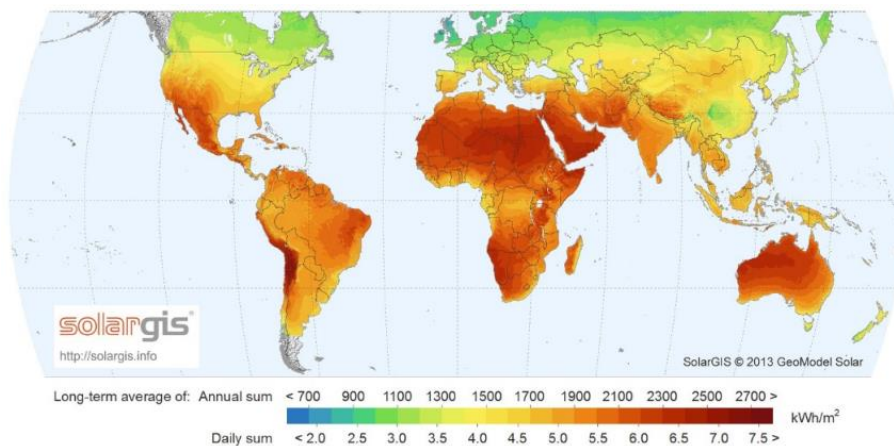

Source: <http://www.city-data.com>

The most simple, effective and cheapest method for the use of the sun's energy is its conversion to thermal energy. Solar thermal energy can be used by direct heating of the process fluid (water) or heating of special fluids and the heat then transmitted to the process water by heat exchanger.

The inconvenience of this type of energy is that its production completely depends on daylight hours (no production during the night) and seasons of the year (especially in a temperate zone).

Although it is possible to heat the water and use it immediately, it is seldom viable in practice due to different dynamics in the hot water production and consumption. The installations containing the storage vessel are more used than the direct use of the heated fluid. The principle of the installation of solar thermal collectors with a storage vessel is presented in the next figure.

Figure 75. A simplified scheme of solar supported water heating with storage

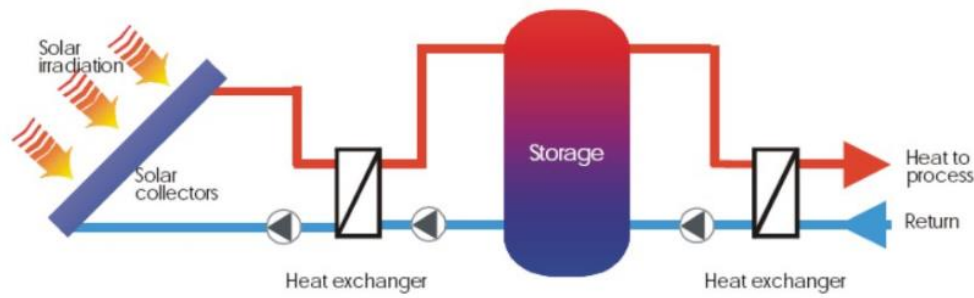

Source: J. Salem, M. Matteini, UNIDO, 2007

Solar thermal energy production and the efficiency of the transformation of the sun insolation energy to thermal energy, depend on many factors such as location, type of solar collectors and their installation and, most importantly, on the desired temperature of the heated fluid.

Figure 76. Solar collector efficiency curve

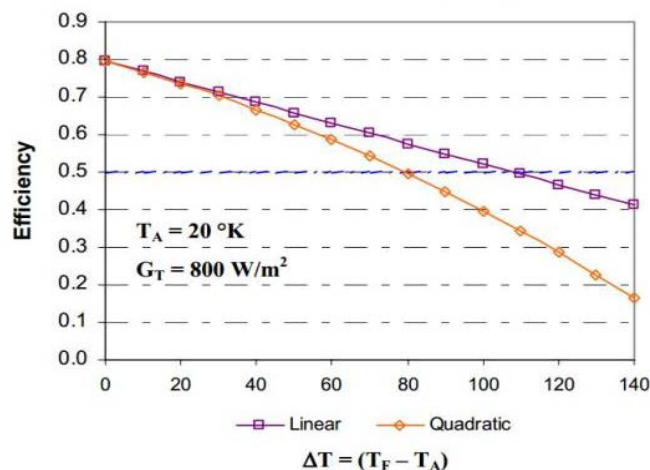

Where: T_F = heated fluid temperature T_A = atmospheric temperature

The maximal efficiency of solar thermal collectors is 50 – 80%, and the efficiency of the whole installation is 30 – 50%.

In practice, even in hot climate zones it is not possible to rely on solar heating only and a fuel fired boiler is necessary; electric energy needed for the fluid/water circulation and transfer pumps should not be overlooked either.

In any case, it is important to make a proper study to design the optimum installation taking into account the desired temperature of the hot water, work out the efficiency and, ultimately the type and cost of a solar collector and of the complete installation.

The main parameters concerning the solar thermal collectors for water heating in a tannery in Spain³⁵ are given as follows:

³⁵ Diseño de una instalación de energía solar térmica para la producción de agua caliente de proceso

- ❖ Mean need of hot water at 52°C: approx. 47 m³/d
- ❖ Mean supplied water temperature: approx. 12°C
- ❖ Mean daily energy consumption for water heating : 9400 MJ/d
- ❖ Mean insolation accepted on collector: 16.42 MJ/m²/d
- ❖ Mean thermal energy production: 8.6 MJ/m²/d
- ❖ The measured efficiency, depending of the type and collector producer and the actual local and seasonal conditions, was 20 – 60%
- ❖ The best efficiency was for collector Atesa (40 – 60%)
- ❖ The optimum surface with optimum inclination (40°C) was calculated as 583.74 m²
- ❖ The area meets approx. 78% of the total necessary thermal energy for hot water, and this value presents the possible thermal energy saving for hot water preparation.

Figure 77. Solar collectors installed in a tannery under UNIDO project in Bangladesh



The second important thermal energy consumer is leather drying.

Solar thermal energy can be used for direct heating of the air; alternatively, special fluids can be used so that the heat is transferred to the air by a heat exchanger, similarly as for hot water preparation.

Practically all that was said regarding the use of solar thermal energy for the water heating also applies to air heating, except for the limitation to store the hot air. It means that if hot air is used directly for drying, the working hours of the air heating should be synchronised with working hours of the leather drying.

The main parameters concerning the solar thermal air collectors for direct air heating of the leather dryers in a tannery in India³⁶ in association with a UNIDO project are as follows:

- Tannery type: from wet blue or vegetable tanned hides to finished leather
- Capacity: approx. 1500000 square ft/month = 140000 m²/month of finished leather
- Leather moisture before drying: 35 – 45%

de una tanería, Luisa F. Cabeza, Miquel Nogués, Joan Roca.

³⁶ Diseño de una instalación de energía solar térmica para la producción de agua caliente de proceso de una tanería, Luisa F. Cabeza, Miquel Nogués, Joan Roca.

- Dryers installed: 2 (the data below are for one dryer)
- Leather moisture after drying: 15 – 17%
- Drying temperature 45 – 62°C; peak temperature of air in solar collector: 84°C
- Average temperature in dryer: 54°C
- Duration of one drying cycle: about 3 h
- Water evaporated during drying: 130.5 kg/h
- Energy required to evaporate 130.5 kg of water at the average temperature of 54°C (enthalpy of evaporation 2372.4 MJ/kg) : 310 MJ/h
- Average solar insolation: 2304 MJ/h/m², average efficiency of solar collectors: 45%
- Energy delivery from the collector: 1.04 MJ/m²/h
- Area of solar collectors required to evaporate 130.5 kg of water per hour: 299 m²
- Surface of the collector: 334 m²

17.4.2. Use of heat pumps

Energy saving is also possible using a heat pump.

According to one of the key laws of thermodynamics, the spontaneous transfer of the heat is possible only from the hotter fluid to the cooler fluid. Nevertheless, according to the laws of thermodynamics, it is possible to transfer the heat from cooler fluid to hotter fluid applying special processes and devices. This system is called a heat pump.

The heat pump uses special fluids, “refrigerants” (because they are used in refrigeration and known as freons). Many freons are prohibited today because if released they destroy the ozone layer in the atmosphere.

Figure 78. A simplified scheme of the heat pump

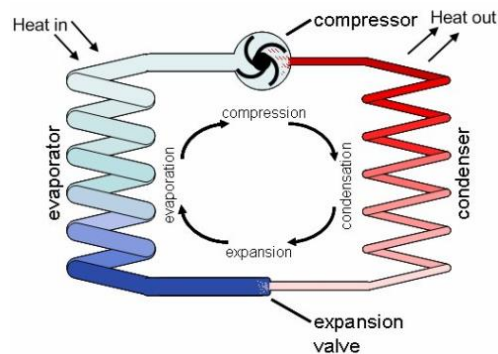

Source : <http://www.diracdelta.co.uk>

As shown in the figure the heat pump operating cycle consists of *evaporation, compression, condensation and expansion*.

For the evaporation of the “refrigerant” it is necessary to take the heat from the fluid. The compression is mostly performed by compressor driven by an electric motor. Due to the compression the refrigerant is heated. During condensation the heat (with the temperature higher than the temperature of the fluid used for evaporation) is transferred to the fluid which should be heated. The expansion is performed by an expansion valve.

The sources of heat from which the heat is taken can be ambient (air or water), soil, underground water, thermal water, (warm) waste water, (warm) waste air and any other

(warm) fluid. Preferable sources of heat are those with the most possible constant temperature during the day and during different years' seasons (e.g. underground water, thermal water, seawater).

The media to absorb the heat with elevated temperatures are mostly water or air.

The heat pump can be economically used in a tannery for the (supplementary) heating of water needed in the process and of the air needed for leather drying.

The use of the combination of direct solar heating with a heat pump is also a viable option, e.g. for heating the fluid to the higher temperature required to heat the process water.

Apart from the construction characteristics of the heat pump, the most important value is the "coefficient of performance" (COP), i.e. the ratio of the thermal energy transferred to the fluid during condensation and the consumed electric energy of the electric motor for the compressor. The COP depends on the difference of the temperature of the source fluid and the temperature of the heated fluid. A rough estimation of COP can also be made using the following formula:

$$COP \leq \frac{T_{hot}}{T_{hot} - T_{cool}}$$

Where:

- T_{hot} is the temperature of the heated fluid, in K
- T_{cool} is temperature of source fluid, in K

The viability of heat pumps as an energy source depends on the ratio of the *thermal energy prices vs. the fuel and the electric energy prices*. Generally, it is considered that recovery of thermal energy by means of heat pumps is normally only economical at a price relation of:

$$\frac{\text{GJ (electric)}}{\text{GJ (thermal)}} < 2 - 2.5$$

The economic use of the heat pump is limited to the relatively low temperature difference.

The thermal energy consumption for building ventilation depends on the difference of the temperature in the building and the ambient temperature and the air exchange rate necessary to keep the demanded air quality in the buildings. The temperature difference is higher in the winter seasons, especially in the temperate zone.

It is reported³⁷ that building heating (temperate zone, France) consumes about 33% of total thermal energy consumption.

To save thermal energy for building ventilation, heat exchange between the warm exhausted air and fresh air is usable. A simple air-to-air heat exchanger has the exchange factor up to 80%. The use of solar air heating is also viable due to the relatively low

³⁷ *Eco-Design, T. Poncet et al.*

temperature of the air for ventilation air and can bring considerable savings in the thermal energy obtained from the combustion of (fossil) fuel.

17.5. Optimisation of electric motors

Electric energy can be saved by using modern electric motors with higher efficiency.

In the EU the new Directive defines 3 classes of electric motors according to their efficiency:

- IE2 (replaces earlier EFF1) > 94%
- IE3 (premium class); from 1. Jan 2017, all motors between 0,75 - 375kW must fulfil the IE3 requirements
- IE4 (super premium class) > 97%

Usually the electric power for industrial use (tannery) is purchased on the higher voltage (10000 V or higher) and transformed to 400 V locally, in tannery and in such cases the price is lower. Generally, the price consists of more components, such as:

- installed electric power
- peak consumed power
- consumed real or active electric energy
- production of reactive energy, connected with the power factor ($\cos \phi$)

Tannery can influence power consumption peaks by planning the dynamic of the use of equipment.

The most important saving of electric power is by reducing the reactive energy. All inductive electric power devices produce the *reactive electric energy*. The *real or active electric energy* is the energy consumed by electric driven devices expressed in Watts (W). The *apparent electric energy* is the electric energy calculated as volts (V) multiplied with current (A), and expressed as volt-amperes (VA).

The relation of real or active electric energy and apparent electric energy is the power factor ($\cos \phi$):

$$\frac{\text{real or active electric energy}}{\text{apparent electric energy}} = \text{power factor } (\cos \phi)$$

Usually if the power factor ($\cos \phi$) is > 0.95 the reactive power is not paid.

To elevate the power factor it is necessary to compensate the reactive energy installing the devices, containing the capacitors. It is possible to install such devices on the main electric distribution station, and/or on the separate devices, having a power factor ($\cos \phi$) < 0.95.

17.6. Own generation of electric power (DG, photovoltaic, wind)

17.6.1. Diesel generator(s), DGs

Very unfortunately, in many developing countries the supply from the mains is not very reliable, "power shedding" patterns are unpredictable and tanners have no choice but to install supplementary sources, their own Diesel generators sets(D.G.s).

Below are rather fresh data about such a case in Somalia³⁸.

The tannery capacity is 3000 pcs skins/d, and it is equipped with two 120kVA Perkins Diesel generator sets. Here are some figures about their performance:

- Each running 6 hours a day, total 12 hours at about 65% capacity
- Energy produced: about 120 kWh
- Diesel fuel consumption: 100 – 120 l/12 h
- The cost of energy: about USD 0.35/kWh
- The rate by the local power suppliers is USD 0.8/KWh (apparently from the nearby hotel Diesel generators).
- The cost of DG set of 120 kVA was about USD 17000 plus USD 5000 for controls and installation.
- The approximate consumption of Diesel fuel for 1 kWh:

$$\frac{110}{120 \times 0.65 \times 12} = 0.12 \text{ l/kWh}$$

17.6.2. Photovoltaic cells, wind

It is also possible to produce one's own electric energy by using the photovoltaic cells (renewable energy), which directly converts the solar into electric energy. Unfortunately, this kind of production of electrical energy is still very expensive, due to very high equipment cost, but once installed the energy is practically gratis. Today's price of this energy is to 4 – 5 and more times the price of the energy from the local electrical energy suppliers. In many countries the state financially supports this kind of production if the photovoltaic installation is connected to the mains.

The inconvenience with this type of energy is that its production entirely depends on daylight hours (no production during the night) and on the seasons (especially in a temperate zone). The electric energy storage is not applicable (exception are special cases), and for this reason the connection to the local supplier is advisable.

The solar electric energy production depends on location, type of photovoltaic cells and type of installation (with fixed or regulated position and inclination).

The efficiency of the direct transformation of solar into electrical energy depends on the material and construction of the photovoltaic cells and today it is from 6 – 18% for industrial products. This efficiency increases constantly by the introduction of new materials and constructions. There are already some experimental materials and constructions with an efficiency of more than 30 %. Normally, the cells with higher efficiency are more expensive.

The best use of the photovoltaic cells is when the installation is vertically to the sunlight. Because the sun "moves" over the horizon, the angle of the sunlight to fixed surface changes; ideally, the position of the installation can be regulated in such a manner that the sunlight is always vertical to the surface.

³⁸ *Berbera Tannery (Pvt) Ltd, Somalia*

Wind using equipment can also be installed as a supplementary source of renewable energy; many factors determine its efficiency but, of course, the very first precondition being frequent and rather steady winds.

17.7. Comparison of thermal energy consumption in a temperate versus a tropical zone

Due to different ambient temperatures many would expect that the overall thermal energy consumption in a tannery in a hot climate zone is considerably lower than in a temperate zone. In reality it is somewhat more complex and worth comparing.

Figure 79. World climate zones – mean temperatures

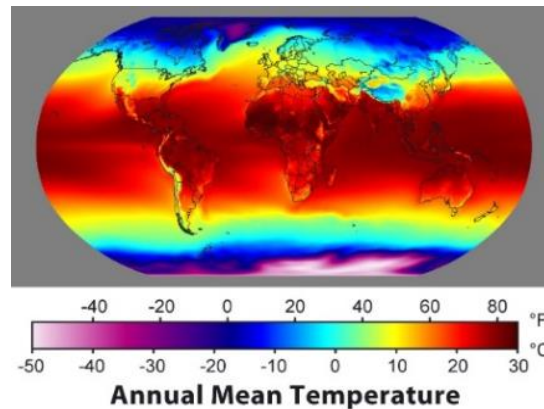

Source: <http://www.wattsupwiththat.com>

A simple computation based on average yearly water and air (ambient) temperatures shows that the amount of net thermal energy needed for heating the float in (sub)tropic zone (South India) is from 20% (dyeing) to about 50 % (bating) of that in the temperate zone (Middle Europe).

Chamber drying in (sub)tropic zone benefits from the higher ambient (air) temperature but at the same time it is negatively affected by high relative humidity and consequently much higher volume of fresh air required: a rough estimation is that on average it is about 20% less than in the temperate zone. However, this advantage almost entirely disappears during the peak of the monsoon season.

However, if the solar energy is used to support water heating, the conditions in the tropic zone are more favourable primarily due to higher insolation.

The insolation in the temperate zone (Europe) is approx. 1500 kWh/m²/y (4.1 kWh/m²/d), and in the tropical zone (South India) approx. 2200 kWh/m²/y (6.0 kWh/m²/d). Thus, the ratio is:

$$2200/1500 \approx 1.5$$

It means that the solar-based production of thermal energy in a hot climate country is about 1.5 times more favourable than in temperate climate.

If heat pumps using ambient air or water as the medium are installed, higher temperature of the heated water or air can be achieved; alternatively, a smaller system can be installed or the best COP can be reached in the same installation.

Obviously, there is no need to heat the building spaces in the tropic zone but there is some consumption for the air-conditioning of offices.

17.8. Energy and water and waste water

17.8.1. Treatment

Leather production needs a very high quantity of water, and produces practically the same quantity of the waste water. Typical water consumption is 12 – 37 m³/t of raw hide for the tannery processing from raw wet salted hides to finished leather (shoe uppers)³⁹. Here the value of 25 m³/t will be taken as representative.

Regrettably, reduction of water consumption does not reduce much the investment and the operation costs of the waste water treatment because the total pollution remains practically the same; only the concentration of pollutants increases which can require more extensive and/or sophisticated treatment.

The tannery waste water temperature is usually higher than the temperature of the fresh water and the ambient air temperature due to use of warm floats in the process; however, due to transportation and relatively long time of the treatment, the temperature during the treatment almost entirely depends on the ambient air temperature. As a reminder, the typical effluent characteristics and treatment effects by the activated sludge process are given in the next table.

Table 48. Typical effluent characteristics and treatment effects⁴⁰

Primary & biological treatment, including nitrification/denitrification, final BOD₅ < 20 mg/l

Parameter	Pollution load in the raw effluent	Raw, composite effluent	Pollution load after biological treatment	Fully treated effluent	Total treatment efficiency
	kg/t of raw hide	mg/l	kg/t of raw hide	mg/l	%
COD	150.0	6,000	6.00	240	96.00
BOD ₅	62.5	2,500	0.50	20	99.20
SS	100.0	4,000	0.75	30	99.25
Cr ³⁺	4.0	160	0.025	1	99.30
S ²⁻	5.0	200	0.025	1	99.50
TKN	12.5	500	1.25	50	90.00
Cl ⁻	150.0	6,000	No change	No change	No change
SO ₄ ²⁻	62.5	2,500	No change	No change	No change

³⁹ IUE Table – Typical pollution values in conventional tannery processes

⁴⁰ As said earlier, all based on consumption/discharge of 25 m³/t of raw hide.

Parameter	Pollution load in the raw effluent	Raw, composite effluent	Pollution load after biological treatment	Fully treated effluent	Total treatment efficiency
	kg/t of raw hide	mg/l	kg/t of raw hide	mg/l	%
TDS	375.0	15,000	No change	No change	No change
Sludge – DS	100		125.00		

The excess sludge, typically 125 kg dry solids/t of raw hides results from the treatment; anaerobic digestion of sludge, separately or together with other tannery wastes (e.g. fleshings) can be applied to produce biogas (methane), which can be used in a tannery. This approach is viable for larger tanneries and/or tannery clusters.⁴¹

17.8.2. Energy consumption related to waste water treatment

A (C)ETP uses only electric power.

The LWG document⁴² estimates the consumption of the electric energy for the effluent treatment at 10 kWh/m³ of the effluent. For the accepted value of 25 m³/t of the raw hide it is 250 kWh/t of raw hides, or 900 MJ/t of raw hides.

In reality the electric energy consumption in the (C)ETP very much depends on its capacity as shown in the UNIDO study⁴³.

Table 49. Some indicative effluent treatment plant parameters

Parameter	Unit	Tannery/cluster capacity, tons of wet-salted hides/day					
		4	20	40	200	400	800
		Treatment capacity, m ³ of effluents/day					
		100	500	1000	5000	10000	20000
Power consumption	kWh/day	1060	3000	4850	18400	32500	54000
Power consumption vs. input	kWh/t raw hide	265	150	120	90	80	70

Power consumption vs. tannery and (C)ETP capacity is presented in the next diagram.

⁴¹ Biomethanation of fleshings and sludge from tannery, UNIDO

⁴² LWG Environmental Protocol Audit Responses Report, Issue 6.0

⁴³ Benchmarking in the Tanning Industry, UNIDO

Figure 80. (C)ETP energy consumption vs. capacity

Chart by M. Bosnić

One theoretical calculation made for a (virtual) tannery of 10 t/d of the raw hides and 25 m³ of the effluent/t of raw hide, gives the value of 1850 kWh/d (6660 MJ/d), or 675250 kWh/y (2431000 MJ/y), or 185 kWh/t (666 MJ/t), or 7,4 kWh/m³ (26.6 MJ/m³) of the effluent.

All general suggestions pertaining to consumption and cost of the electric energy for leather processing are also valid for the effluent treatment.

17.8.3. Comparison of energy consumption in (C)ETPs installed in temperate and tropical zones

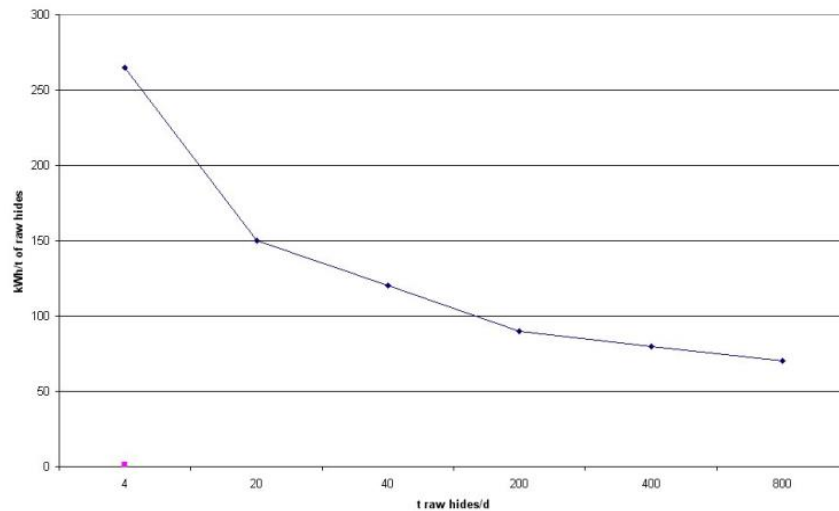
It might be of interest to compare energy consumption needed for effluent treatment (the largest consumer being the biological step).

Waste water temperature significantly influences the parameters of the waste water treatment. The two most important values affected are:

- *kinetic coefficient* for the biological treatment
- consumption of the energy for the aerobic biological treatment

The *kinetic coefficient* influences many parameters of the biological effluent treatment by activated sludge process: the Mean Cell Residence Time (MVRT), Solids Retention Time (SRT), Hydraulic Retention Time (HRT), Volume of the aeration Basins (V), and excess sludge production.

Based on effluent temperatures of 15°C and 25°C for temperate and tropical zone respectively it can be computed that the kinetic coefficient in hot climate is:

$$K_{25} = K_{15} \times 1.04^{(25 - 15)} = K_{15} \times 1.04^{10} = 1.48 K_{15}$$

i.e. about 50 % higher.

However, the influence of the kinetic coefficient is mostly not directly proportional, and the calculation of the real benefit is very complicated and depends on many other factors. In any case it significantly influences the dimensioning of the (C)ETP and ultimately the investment costs.

In some regions of temperate zones the temperature during winter period can be very low and sometimes it is necessary to have a (C)ETP in a closed building, which considerably increases not only the investment, but also the operation costs (ventilation, air treatment).

At a temperature of $< 10^{\circ}\text{C}$ the biological aerobic activated sludge effluent treatment is slowed down and the nitrification practically ceases.

17.8.4. Energy consumption for the aerobic biological treatment

While higher ambient temperatures are good for the construction costs, they have a negative impact on consumption of electric energy consumption: the negative difference between the elevated coefficient of the velocity of the oxygen solution in the water and reduced solubility of the oxygen in the water results in lower Oxygen Transfer Rate (OTR).

The values of the factor for the correction of OTR in function of the temperature are shown in the following diagram⁴⁴.

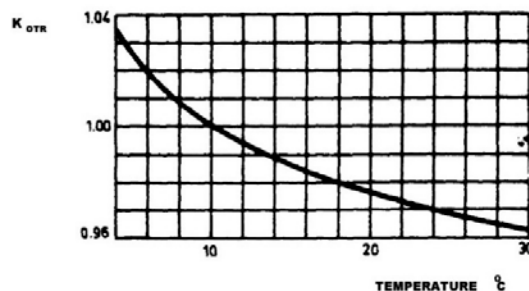

Because of the lower OTR, it is necessary to introduce more air for the aeration in the biological activated sludge treatment for the same configuration of the (C)ETP, and thus use proportionally more electric energy.

Thus, while the consumption of the biological treatment under given conditions in a temperate zone is approx. 63.3 kWh/ton of raw hide, in the hot climate zone with the corresponding (lower) Oxygen Transfer Rate (OTR), the electric energy consumption is slightly higher:

$$\frac{63.3}{0.98} = 64.6 \text{ kWh/t of rawhide}$$

In summary it can be said that while the biological treatment in hot climate zones is positively influenced by higher effluent temperature, lower solubility of oxygen and lower

⁴⁴ W. v. d. Emde: *Suvremena primjena procesa sa aktivnim muljem u kondicioniranju otpadnih voda naselja i industrije (Contemporary practice of the activated sludge in the conditioning of the communal and industrial wastewater)*, Sarajevo 1973.

oxygen transfer rate (OTR) have a negative effect and result in a slightly higher consumption of electric energy.

17.9. A brief overview of the main energy savings measures

Considerable savings can be made by careful selection of methods and equipment as well as close control of thermal efficiency. Wherever possible, the principle “no production, no consumption” should be strictly followed.

Below is a brief overview of typical energy savings measures taken from the UNIDO paper Benchmarking in the Tanning Industry.

Check list 4.1: Energy management

4.1	Description	Yes	No
	Energy management		
4.1.1	All warm water and steam pipes well insulated, no leakages		
4.1.2	Hot-cold water mixing system well calibrated, short adjustment cycles		
4.1.3	Optimised mechanical dewatering (sammying)		
4.1.4	If viable natural drying used (especially for high quality soft leather, skins)		
4.1.5	Optimal drying regime in drying chambers and tunnels (e.g. higher air velocity, lower temperature)		
4.1.6	Infrared heating used for drying in finishing		
4.1.7	Solar energy supported drying		
4.1.8	Use of heat pumps		
4.1.9	Electromotors' capacity optimized (usually 75% of maximum performance)		
4.1.10	Hot water/steam boiler and auxiliary components design and performance allows only lowest technically possible losses		
4.1.11	Wherever viable, waste heat (e.g. from vacuum driers, compressors) recovered		
4.1.12	Steam condensate recovered		
4.1.13	The scale of operations permitting, part of energy needs obtained from anaerobic digestion of fleshings and sludge		
4.1.14	The scale of operations permitting, part of energy needs obtained from incineration from chrome-free solid wastes (fleshings, fat)		
4.1.15	Automatic and/or manual controls of heating/cooling/ventilation/lighting systems in place		
Recommendations:			

Check list 4.2: Energy consumption

4.	Description	Unit	Value
	Energy consumption and utilization efficiency		
4.2.1	Energy consumption vs. input (t of raw hide)	GJ/t	
4.2.2	Energy consumption vs. output (wet blue/crust/finished leather)	MJ/m ²	
4.2.3	Energy used for heating/cooling of store rooms and offices	GJ/year	

4.	<i>Description</i>	<i>Unit</i>	<i>Value</i>
4.2.4	Total energy consumption over a certain time span (working/non-working day, month, year)	GJ/working day	
4.2.5	Share of own energy produced (digestion, incineration) vs. total energy consumption	%	
4.2.6	Energy consumption for effluent/waste treatment vs. raw hide input and/or effluent volume (see also <i>Chapter 10</i>)	GJ/t or m ³	
Recommendations:			

18. OCCUPATIONAL SAFETY AND HEALTH IN THE WORKPLACE (OSH)

18.1. Introduction

The OSH issues in tanning operations are extensively addressed in the paper *Occupational safety and health aspects of leather manufacture* prepared by UNIDO and jointly published with the Council for Leather Exports, Chennai, India in 1999. The paper is still quite relevant especially regarding conditions prevailing in developing countries. There is also a small “dedicated” brochure *How to deal with hydrogen sulphide gas*.

The OSH general principles are covered by ISO: 18000.

Accordingly, here are only a few highlights, including some considerations about the OSH impact of cleaner technologies: the fact that on the whole they are environmentally friendlier does not mean that they are necessarily quite innocent and/or without bringing some (new?) risks, possibly even not fully recognized yet.

18.2. Basic principles of OSH management

While exploring and implementing OSH prioritization measures it is recommended to adopt the following approach:

1. Eliminate the hazard (e.g. by substitution of hazardous agents; putting up a protective fence)
2. Minimize the impact of the hazard (e.g. ventilation, general cleanliness)
3. Protect the worker against the hazard’s impact (e.g. distribution of PPE; personal hygiene)

Figure 81. Basic principles of OSH management

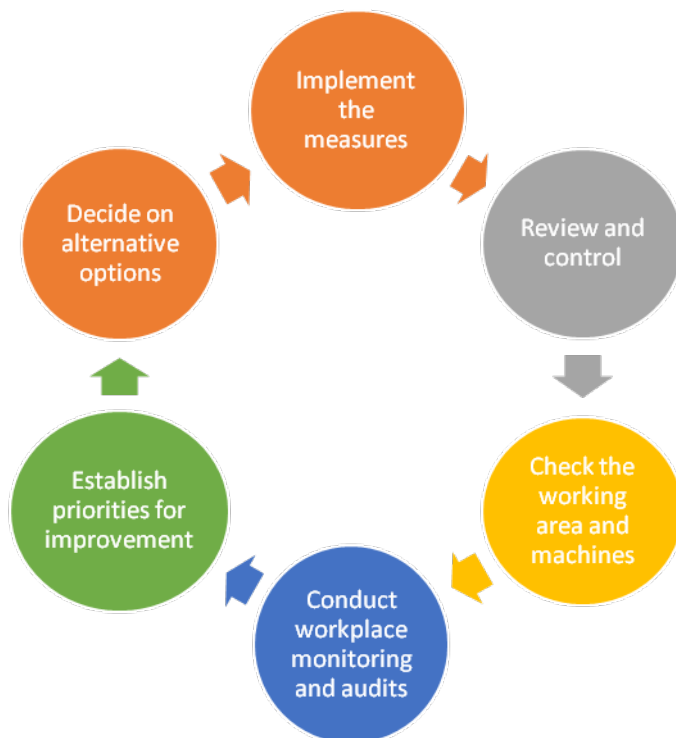

Experience has shown that management's commitment to improve the OSH standards at work is an essential prerequisite.

18.3. Typical injuries and negative health impacts in tanneries and tannery effluent treatment plants

- Injuries caused by falls due to slippery floors, unguarded door openings and pits
- Injuries on fingers, hands, legs and head from contact with/hits by moving machinery parts
- Skin burns and allergic reactions, respiratory problems either due to dust or chemical agents/gases either in course of (inappropriate) handling or due to poor ventilation
- Shocks and burns caused by contact with live electrical installations (inadequate protection/poor practice, corrosion)
- Injuries caused by fire
- Impairment of hearing and eye sight

18.4. The main causes of safety risks and health hazards

Faulty designs and/or poor maintenance of machinery and equipment

A series of events can ultimately result in an accident.

Chemical substances

Applied before or during the process they can affect safety and health of personnel exposed to them (e.g. by inhalation, ingestion, skin contact)

Working conditions

They influence staff behaviour and thus indirectly contribute to accidents and health hazards.

Employees' job experience, training and attitude

General education and, in particular, understanding of and specific training in containment of safety risks and hazards are of paramount importance; this applies not only to operators but possibly even more to managers and supervisors.

18.5. Malodour

The traditional perception of tanning is associated with irritating malodour mainly caused by hydrogen sulphide and ammonia and some other compounds resulting from protein decomposition; in reality it is only a sign of bad practices and, above all, of poor housekeeping.

Table 50. The main categories of air-transmitted hazardous or irritating substances

Substance/cause	Mitigation/elimination	Limitations, warnings
Malodours in stores	Proper raw material preservation; good housekeeping and ventilation	Higher preservation and energy costs
Ammonia	Replacement of ammonium compounds in deliming (e.g. by CO ₂); Scrubbing and/or bio-filtration of extracted air	Not applicable to pelts with thickness over 1.5 mm; old drums

Substance/cause	Mitigation/elimination	Limitations, warnings
H₂S tannery	Good segregation of liming (alkaline) and tanning (acid) streams; the pH of effluents containing sulphide kept above 9.5 until treatment (oxidation)	Oxidation reversible!
H₂S, ETP	Continuous aeration, immediate (catalytic) oxidation	Long collecting channels, power shedding
Glutaraldehyde	Modified glutaraldehyde with lower vapour pressure; automated dosing system	Cost
Volatile (halogenated) organic compounds, VOCs (mainly finishing)	Water based finishing; replacement by acceptable solvents; efficient extraction and wet scrubbing/adsorption systems	"Pure" water based coating inadequate for some articles; treatment cost

18.6. Hydrogen sulphide gas, H₂S

Nearly all fatal accidents in tanneries are caused by hydrogen sulphide gas which is why it is addressed separately here.

Hydrogen sulphide gas is evolved by the mixing of sulphide containing liming liquors/waste water (alkaline) and tanyard effluents (acidic), especially in deep channels and pits and at higher concentrations when the typical (warning!) smell is not pronounced. Strict segregation of alkaline and acidic streams to ensure that the pH will not fall below 9.5 is essential.

Figure 82. The main tannery streams, segregation

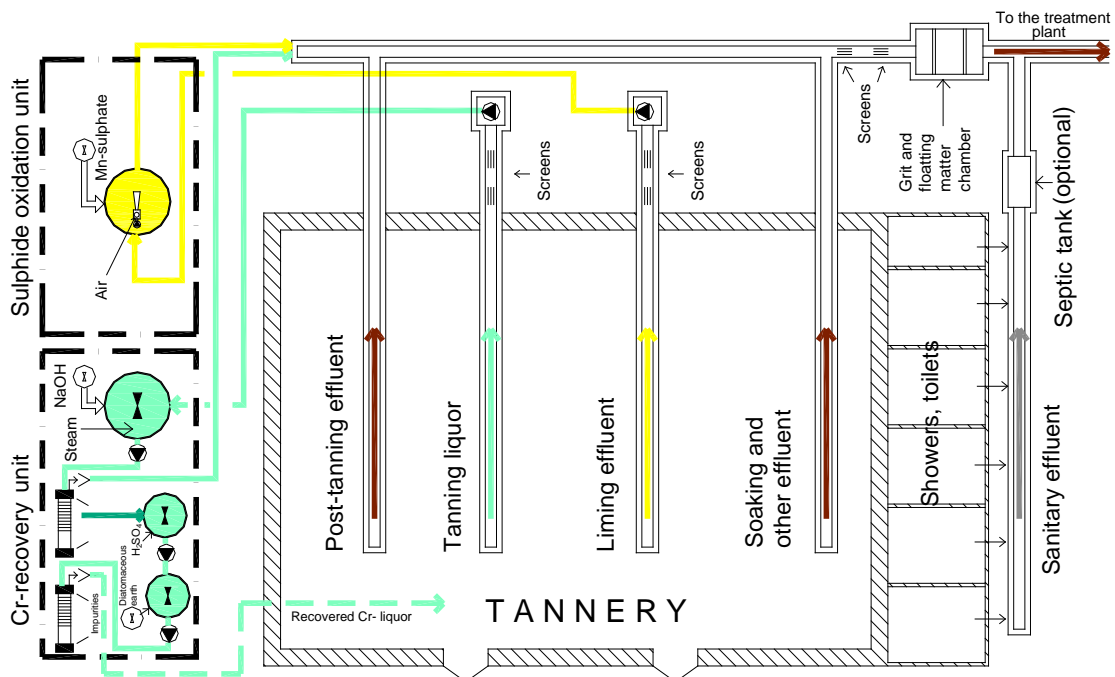

Hydrogen sulphide gas is quite easily eliminated by catalytic oxidation using manganese sulphate as a catalyst before being mixed with acid effluent or being discharged to the

general mixing tank which generally has a pH of 8.5– 9.

It is useful to recall once again the properties of hydrogen sulphide gas, H₂S, still by far the most frequent killer in tannery accidents, mainly in inadequately ventilated spaces and especially in pits and channels.

Table 51. Poisoning effects of hydrogen sulphide gas (H₂S)

Exposure Ppm	Time	Impact on unprotected person
0.03	No time limit	No effect
0.08 – 2.0	No time limit	(Mal)odour threshold
10	Up to 8 hours	No effect
15	Up to 15 minutes	Threshold limit value
15 – 200	Up to 15 minutes	Headache, nausea, general weakness, pain in legs
200 – 500	1 minute	Irritation of nose & throat, vertigo, blurring of vision, loss of consciousness lasting a few minutes
500 – 900	1 minute	Profound coma, convulsions, disorientation after recovery
> 900	1 minute	Instant coma and death

ppm = parts per million

However, in view of new toxicological data, authorities in some countries have started reducing the recommended chronic exposure limits to hydrogen sulphide; the 8 hour time weighted average Threshold Limit Value (TLV-TWA₈) for H₂S is brought down from 10 ppm to 1 ppm, and the Short Term Exposure Limit (TLV-STEL) from 15 ppm to 5 ppm so that even confirming compliance with the new standards will be a challenge for health and safety practitioners.

Figure 83. Cover page of UNIDO H₂S manual

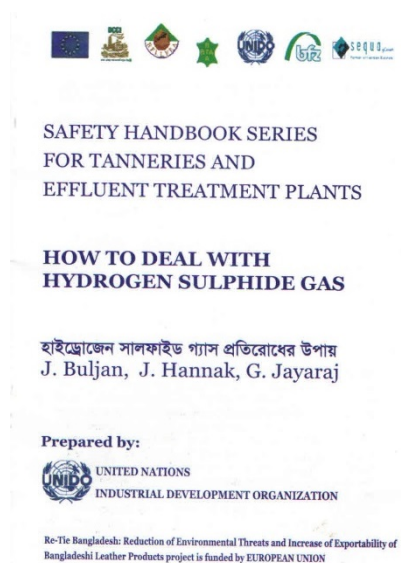

Instruments needed to detect and monitor H₂S exposures can be either fixed or portable whereas personal detectors are worn by employees and typically sound alarm at levels of 10-15 ppm. Due to nearly permanent life-threatening hazards, H₂S meters are always

positioned at critical points and/or carried by staff. Also, certain activities such as entering pits can be carried out only in the presence of skilled supervisor and the worker must be equipped with a safety harness.

Instruments measuring H₂S presence

- Stationary
- Portable
- Personal detectors



Due to nearly permanent H₂S life threatening hazard:

- H₂S meters have to be permanently positioned at critical points and/or carried by staff
- Entering pits only in presence of skilled supervisor, the worker equipped with safety harness.

18.7. Bad odour problems related to effluent treatment plants

Odours associated with waste water are difficult to quantify because they are caused by a wide variety of compounds. It is a nuisance that is more qualitative than quantitative: sensitive persons easily detect very low concentration of odoriferous substances in the air (sulphides/other sulphur compounds, ammonia, amines, etc.). Local geographic and climatic conditions such as wind direction, land shape, air humidity, ground and air temperature, etc. greatly influence the level of the problem. Along the treatment line the main sources of bad odour are:

- Equalisation & sulphide oxidation
- Sludge thickening
- Biological aeration
- In-plant storage of the dewatered sludge
- (Temporary) sludge disposal site

Yet, the main source of bad odour remains to be the stripping of hydrogen sulphide; however, it is not the concentration of sulphide *per se* but the lowering of pH: the not disassociated H₂S is present only at pH below 10. Thus, it is crucial to control the pH and if needed alkalis like NaOH or lime are added to make the pH > 9.5-10 are added. More extensive, uninterrupted aeration may help but sometimes rigorous (and expensive) methods like adding hydrogen peroxide or pure oxygen are necessary. Nowadays, in some places nearly the entire ETP is covered and the air purified.

(C)ETPs & OSH

General and specific OSH measures, including use of Personnel Protection Equipment (PPE) about handling equipment and chemicals like fencing, protection from moving parts, storing & handling of chemicals etc.



also apply to (C)ETPs!!!

18.8. Particulate matter (dust)

Shaving and, in particular, buffing are the main sources of particulate matter (dust).

Higher accuracy of both splitting and shaving can drastically reduce the amount of particles carried by air. Mitigation measures primarily include correctly designed and maintained low noise extraction ventilation systems fitted with bag filters or wet scrubbers which are essential; the target is 3 - 6 mg /Nm³ of particulate matter in exhausted air expressed as a 30 minute mean.

Mandatory use of appropriate Personal Protection Equipment (PPE) such as masks, goggles and ear protective equipment (mufflers) is now a widely accepted standard.

A specific category are solid aerosols with a particle size smaller than 200 x 10⁻³ mm; in a tannery they can be generated by (surface) aerators in waste water treatment plants.

18.9. Noise and vibration

There is a long list of potential culprits, i.e. machines, equipment and operations responsible for pollution by noise and vibrations:

- Drum driving gears
- Chemicals mixers
- Various pumps for water, float collection/recirculation, waste water, circulating reagents in scrubbers, etc.
- Extraction and aeration fans
- Air compressors
- In-plant (fork lifts) external transportation
- Diesel power generating sets

Furthermore

- Sammying and setting out
- Shaving, especially dry shaving
- Staking, especially vibro-stakers
- Buffing and dedusting, together with dust collection systems
- Finishing (coating), especially by rotary spraying machines together with air extraction and scrubbing systems.

The main noise and vibration preventative and/or mitigation measures:

- Timely preventative - maintenance, lubrication
- Where applicable replacement of metal with hard plastic pinion gears
- Consider using low noise spray-guns
- Better foundation and noise & vibration resilient machine mountings (e.g. for sammying and vibro-staking machines)
- Change of operating speeds, avoid resonances
- Placing equipment such as exhaust fans on the outside of the (main) building
- Modify the building layout
- Silencing of exhaust outlets
- Using purpose designed, properly balanced fans; ducts designed to ensure smooth airflow

18.10. Critical review of any new (cleaner) leather processing method

Traditionally, chemicals suppliers tend to reveal as little as possible about the composition of specialty agents they promote; as a rule, apart from mandatory data for safety data sheets they are silent about their environmental performance, for example about the COD load and biodegradability.

Also, as said earlier, the fact that on the whole a new process or agent are environmentally friendlier does not mean that it is necessarily quite innocent and/or without bringing some (new?) risks, possibly even not fully recognized yet. A good example is carbon dioxide deliming.

Replacement of ammonium sulphate with carbon dioxide in deliming

Purpose: *Reduction of nitrogen load in effluent*

Positive impact:

- ✓ Reduced nitrogen load in effluent
- ✓ Elimination of potential hazards due to workers' exposure to ammonia gas (respiratory problems, eye irritation)

Potentially negative impact:

- Dizziness, headache, hyperventilation due to excessive inhalation of carbon dioxide (e.g. by leakage) even, in the worst and unlikely case asphyxiation.
- Poisoning due to inhalation of the hydrogen sulphide gas due to reaction of carbon dioxide and the residual sulphide in pelt.

18.11. Material Safety Data Sheets, MSDS

There are many different categories of safety and health hazards related to substances and specialty chemicals used in the tanning process. They are classified according to their acute oral toxicity, irritation to the skin and mucous membranes as well as according to their potential mutagenic, teratogenic and carcinogenic effects and the effects of repeated or prolonged exposure. This must be clearly stated in Material Safety Data Sheets, MSDS and appropriately marked on packaging to make it possible to classify the product at one glance.

Potential hazards by the product are not identical with the real risk. A product handled by observing safety precautions and properly used is not (necessarily) harmful; it is harmful only if the user is exposed to it in a particular way. Furthermore, the route (inhalation, ingestion, skin contact), the quantity/concentration, duration and similar factors determine the level of exposure and thus the overall risk.

In that context it is useful to be familiar with some basic terms and common abbreviations concerning the safe handling of chemicals:

Dose (D):	Measured or prescribed amount of a substance.
Dtox	toxic dose
DE	efficient dose
DL(LD)	lethal dose
ID	individual dose
IMD	individual maximum dose
MD	maximum dose
MDD	maximum daily dose
ND	normal dose
DD	daily dose

The lethal dose is subdivided into:

LD ₁₀₀	The absolutely lethal dose
LD ₅₀	The average lethal dose, at which 50% of the animals in the test are killed
LD ₀	The maximum non-lethal dose.

Toxicity, defined as the degree of being poisonous is subdivided in:

- acute toxicity = poisoning produced by a single dose
- subchronical = poisoning produced by toxicity repeated dosage within a relatively short time
- chronical toxicity = poisoning produced by repeated dosage over a relatively long time.

Flash Point: The lowest temperature, at a pressure of 1013.25 mbar, at which vapours are developed and with air over the liquid level form a mixture that can be inflamed by foreign ignition.

The importance of having the key warnings and instructions in language and signs fully understood even by less skilled workers cannot be overemphasized.

Without going into details here, all involved should, for example, understand signs established by international regulations concerning the transportation of materials classified as Compressed, liquefied or dissolved gases under pressure, Inflammable, liquid materials (combustible liquids)/Inflammable materials, Spontaneously combustible materials, Oxidizing materials, Toxic materials, etc.

Danger labels prescribed by IMDG Code
(International maritime dangerous goods code)
Marking according to the Regulation on Dangerous Goods.

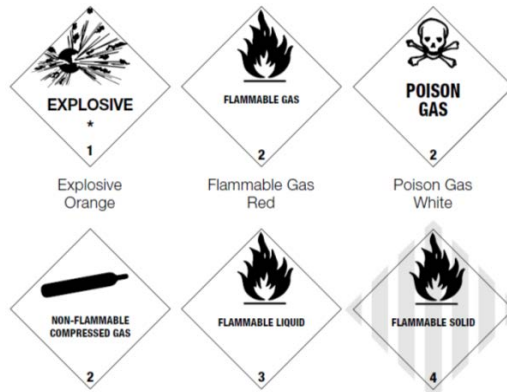

For example, the content of the Material Safety Data Sheet, MSDS in the EU (EC-MSDS) has to include:

1. Substance/preparation name, company name, intended use
2. Composition/information on hazard ingredients
3. Possible hazards
4. First aid measures
5. Fire-fighting measures
6. Accidental release measures
7. Handling and storage
8. Exposure controls and personal protection
9. Physical and chemical properties
10. Stability and reactivity
11. Toxicological information
12. Ecological information
13. Disposal considerations
14. Transport information
15. Regulatory information (labelling)

18.12. Benchmarking in the area of occupational safety and health (OSH)⁴⁵

The main factors relevant for health hazards and safety at work are machines and equipment, chemicals, working environment and conditions and people. As a rule, OSH standards in a tannery are among the best visual indicators of its overall performance.

7.	Component	OK	Not OK
	Chemicals, general		
7.1	Material safety data sheets of all chemicals readily available		
7.2	Staff familiar with the basic content of data sheets		
7.3	All chemicals stored in orderly manner		
7.4	All containers correctly labelled		

⁴⁵ For a full overview, including a very detailed list of items to be monitored, refer to the study "Occupational Safety and Health Aspects of Leather Manufacture" by J. Buljan, A. Sahasranaman and J. Hannak, jointly published by UNIDO and COUNCIL FOR LEATHER EXPORTS (CLE), India, 1999.

7.	Component	OK	Not OK
7.5	Staff familiar with the meaning of signs and symbols, risks and first aid, especially concerning hydrogen sulphide (H ₂ S)		
7.6	Transfer and dosing of chemicals ideally in fully closed systems		
7.7	Concentration of (hazardous) chemicals levels below TLV in terms of both TWA and STEL		
7.8	Hazardous/inflammable chemicals stored in proper, prescribed manner		
7.9	Limited access to areas with hazardous chemicals		
7.10	Residues disposed in prescribed manner		
7.11	Small empty containers returned or disposed of in prescribed manner		
7.12	Use of PPE: gloves, goggles, aprons, boots, etc.		
	Machines, general		
7.13	Machine's position allows smooth work flow and maintenance		
7.14	Preventive/regular maintenance and spare management in place		
7.15	Active safety devices (pneumatic, ultrasonic, optical or electrical) installed and functioning		
7.16	Electrical installation in accordance with high safety standards in all respects (corrosion, earthing, water, gases, sparking.)		
7.17	Passive safety devices (guards, fences) on moving parts (gears, belts, etc.) installed, firmly anchored		
7.18	Noise, vibration, radiant heat, dust, gas/vapours levels in accordance with high legal standards		
7.19	Operation instructions, understandable to the operator, fixed at suitable place		
7.20	Operation controls buttons/switches labelled in the language of operators		
7.21	Emergency OFF button/switch within easy reach of operator and helper		
7.22	Strict adherence to preventive checks and maintenance schedules		
7.23	Use of PPE		
	Workplace environment and conditions		
7.24	Even floors with slip-proof surface, covered floor openings		
7.25	Drains covered with corrosion resistant grates		
7.26	Safe and clearly marked transport and passageways		
7.27	Adequate lay-out/spacing, room lighting, ventilation, humidity		
7.28	Fixed and portable hydrogen sulphide (H ₂ S) and ammonia (NH ₃) meters used in hazardous areas (beamhouse, waste treatment)		
7.29	Personal breathing apparatuses readily available in higher risk areas		
7.30	Safety and health protection signs and instructions visibly displayed		
7.31	Staff trained and uses personal protective equipment: gloves, aprons, boots, goggles, hearing protection, harnesses for entering pits, etc.		
7.32	First aid kits readily available, staff trained how to use them		
7.33	Appropriate fire-fighting equipment ready at marked locations		
7.34	Well-established emergency procedures, regular drills		
7.35	Well-established accidents prevention and monitoring system and records ⁴⁶		

⁴⁶ Includes not only records but also critical assessment of causes as well as corrective and preventive actions taken (e.g. training) to avoid the same accidents happening again.

7.	<i>Component</i>	<i>OK</i>	<i>Not OK</i>
	Machines, example of specific cases		
	<i>Drums</i>		
7.36	One-metre space provided in the rear and on the sides of the drum		
7.37	Fixed barrier guards installed in the rear and side areas to prevent access to drum and drive while the drum is rotating		
7.38	Removable, interlocked safeguard installed at the front, which automatically stops rotation of the drum if not in place or opened		
7.39	All operating control switches marked in local/operator's language and/or colour (e.g. OFF – red, ON – green)		
7.40	The control switches installed close to the drum but away from any moving parts		
7.41	The motor's electrical starter will not restart on its own when the supply is restored after a power failure		
7.42	Electrical cables armoured and routed in corrosion-proof conduits		
7.43	Electrical enclosures and motors have IP55 degree protection		
7.44	Motor terminal boxes covered and closed		
7.45	Cable entry holes have gland fittings		
7.46	All openings in the electrical enclosure boxes closed with tight fitting plugs to prevent the ingress of dust and water		
7.47	Electric motor body and base frame earthed		
7.48	All electrical enclosures of switchgear connected with corrosion protected earth wires; if insulated, then marked as per international colour code (yellow and green)		
7.49	Metal parts/bands on wooden drums corrosion protected; if corroded, replaced		
7.50	Power supply to the drum motor disabled or locked out (by removing fuses/locking isolator switch) before any maintenance work		
7.51	A mechanical stop-device (brake) used to prevent accidental drum rotation during loading/unloading and repair and maintenance work		
7.52	A sign board "Under repair" or "Men at work" visibly posted during repair and maintenance work		
7.53	Appropriate devices (ducts, hoses) ensure controlled draining of floats – no flooding		
7.54	Sufficient time allowed for harmful gases, fumes, vapours to exit before checking or attempting removal of entangled hides/skins inside the drum		
7.55	Another person keeps watch outside in (the exceptional) case of an operator entering the drum		
7.56	Drum operators and helpers wear personal protective equipment (gloves, waterproof, non-slip footwear) especially during loading/unloading, when checking leather; all chemicals handled in prescribed, safe manner, etc.		

19. CARBON FOOTPRINT – LEATHER CYCLE ANALYSIS (LCA)

19.1. General

Climate change(s), greenhouse effect, carbon footprint and related topics are very present on the global media scene; there is no shortage of reports, statements, debates and opposing claims. Political decisions with strong financial implications are already being implemented.

Figure 84. Evolution of global population (red) and global carbon dioxide emissions (blue) since 1900.

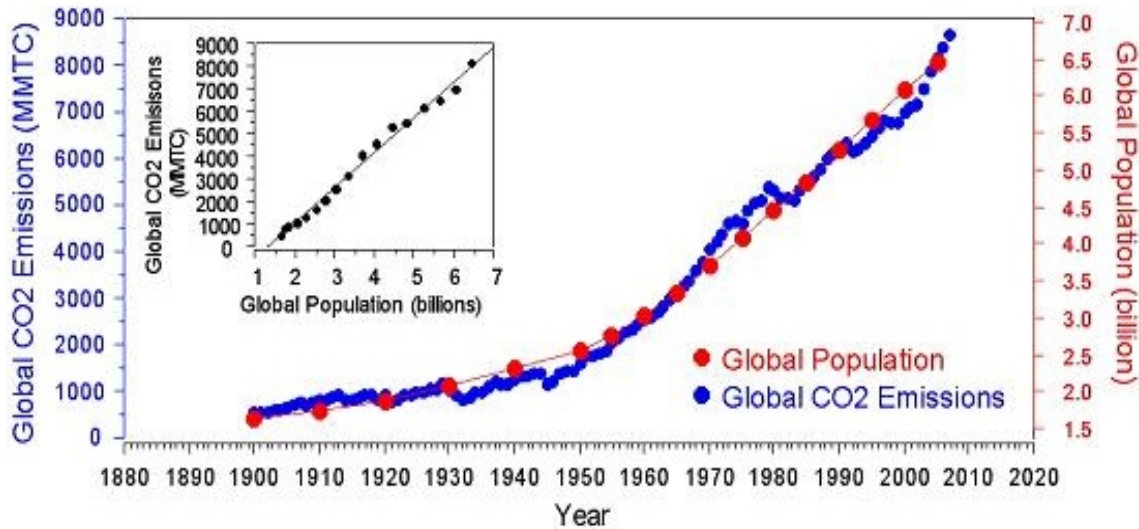

The inset shows the tight relationship between population and CO₂ emissions⁴⁷.

Figure 85. Cattle stock population

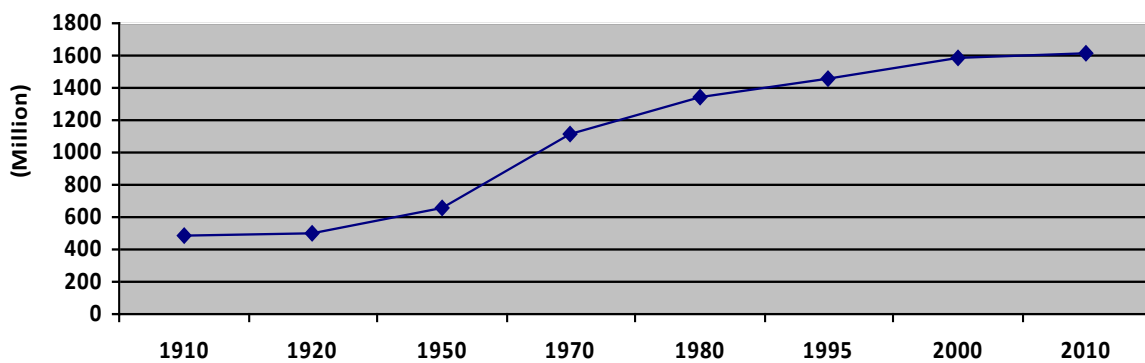

Source: Reich, FAO

As it is already widely known, an important part of CO₂ emissions emanate from livestock (cattle) population and this is certainly of interest to the leather sector. For an illustration,

⁴⁷Population data are from the U.S. Census Bureau, and CO₂ emissions data are from the Carbon Dioxide Information Analysis Center (CDIAC).

Figure 2 shows cattle stock since 1910; it can be assumed that a leather production increase over the last 100 years has followed a similar pattern.

Since GHG emissions are one of the main environmental challenges, it is very likely that figures about GHG or CO₂ emissions will be part of mandatory information on any product and will be “taxed” to encourage the use of more sustainable products. For some products (e.g. cars) such taxes are already introduced in some regions.

Apart from a brief “refresher” about the rather specific terminology related to these topics, this paper will only deal with issues closely related to the tanning industry; and although the leather industry is not a major contributor to CO₂ emissions, it cannot afford to ignore this issue. Therefore, the leather industry needs to:

- i. Develop suitable tools and reduce CO₂ emissions
- ii. Agree on the methodology to measure and to report on CO₂ emissions

Actually, UNIDO was among the very first international organization that turned its attention to this particular area and its relevance to the leather sector in belief that in view of consequences already felt by the trade the tanners simply could not afford to ignore the challenge. Particular pressures come from companies eager to demonstrate green credentials of their suppliers.

The study *Life Cycle Assessment, Carbon Footprint in Leather Processing* prepared by F. Brugnoli for the XVIII Session of UNIDO Leather and Leather Products Industry Panel, Shanghai, 2012⁴⁸ was not only extensively discussed by eminent international leather specialists but it has triggered a series of activities involving different regional and global establishments.

Accordingly, in this paper an attempt is made to provide some highlights from the said study presented and discussed in Shanghai, expanded with supplementary information and views pertaining to the subject.

19.2. Glossary and basic concepts

CF	Carbon Footprint
CF-PCR	Carbon footprint product category rules
CO ₂ e	Carbon dioxide equivalent
GHG	Green House Gasses
GWP	Global Warming Potential
ILCD	International Reference Life Cycle Data System
IPCC	Intergovernmental Panel on Climate Change

⁴⁸ Later on in the text referred as FB-UNIDO

IPP	INTEGRATED POLLUTION PREVENTION
IPP	Integrated Product Policy
ISO	International Standard Organisation
LCA	Life Cycle Analysis or Assessment
LCI	Life Cycle Inventory Analysis
LCIA	Life Cycle Impact Assessment
PCF	Product Carbon Footprint
PCR	Product Category Rules
TOE	Tonnes of Oil Equivalent
UNEP	United Nations Environment Programme
UNIDO	United Nations Industrial Development Organizations
WBCSD	World Business Council for Sustainable Development

Source: FB-UNIDO

19.2.1. Terms and Definitions (FROM ISO DIS 14067)

For easy understanding, the most important are reported here. For additional terms and definitions, please refer to ISO DIS 14067 (1 & 2), from which the following definitions have been taken:

- **Carbon Footprint (CF):**

Weighted sum of greenhouse gas emissions and greenhouse gas removals of a process, a system of processes or a product system, expressed in CO₂ equivalents.⁴⁹

- **Product Carbon Footprint (PCF):**

Carbon footprint of a product system.

- **Product Category Rules (PCR):**

A set of specific rules, requirements and guidelines for developing environmental declarations for one or more product categories.

- **Carbon Footprint Product Category Rules (CF-PCR):**

A set of specific rules requirements and guidelines for developing carbon footprint declarations for one or more product categories.

- **Product System:**

- Collection of unit processes with elementary and product flows, performing one or more defined functions and which models the life cycle of a product.

- **Life Cycle Assessment (LCA):**

Compilation and evaluation of the inputs, outputs and the potential environmental impacts of a product system throughout its life cycle.

- **Life Cycle Inventory Analysis (LCI):**

A phase of life cycle assessment involving the compilation and quantification of inputs and

⁴⁹Another good definition of CF: A carbon footprint is the total amount of CO₂ and other greenhouse gases, emitted over the full life cycle of a process or a product. It is expressed in grams of CO₂ equivalents.

outputs for a product throughout its life cycle

- **Functional Unit:**

Quantified performance of a product system for use as a reference unit.

- **Products:**

Any good and services

- **Primary Data:**

Quantified value originating from a direct measurement or a calculation based on direct measurements of a unit process of the product system at its original source.

- **Secondary Data:**

Quantified value of an activity or life cycle process obtained from sources other than the direct measurement or calculation from direct measurements.

- **Greenhouse Gas (GHG)⁵⁰:**

Gaseous constituent of the atmosphere, both natural and anthropogenic, that absorbs and emits radiation at specific wavelengths within the spectrum of infrared radiation emitted by the Earth's surface, the atmosphere, and clouds.

- **Global Warming Potential (GWP): F**

Factor describing the radiative forcing impact of one mass- based unit of a given GHG relative to an equivalent unit of carbon dioxide over a given period.

- **Carbon Dioxide Equivalent (CO₂e):**

Unit for comparing the radiative forcing of a GHG to carbon dioxide.

Source: *FB-UNIDO*

19.2.2. Environmental Footprint

Several different standards are available today to footprint product and companies activities; here are their main approaches and characteristics to provide a general overview and to identify potential commonalities for harmonization purposes.

The analysis is based on the EUROPEAN COMMISSION JOINT RESEARCH CENTRE, Institute for Environment and Sustainability (Ispra, Italy, November 2011) Analysis of Existing Environmental Footprint Methodologies for Products and Organizations: Recommendations, Rationale, and Alignment.

ISO 14040:2006 Environmental management - Life Cycle Assessment -- Principles and framework

It describes the principles and framework for Life Cycle Assessment, including: definition of the goal and scope of the LCA, the life cycle inventory analysis (LCI) phase, the life cycle impact assessment (LCIA) phase, the life cycle interpretation phase, reporting and critical review of the LCA, limitations of the LCA, the relationship between the LCA phases, and conditions for the use of value choices and optional elements. It also covers life cycle assessment (LCA) studies and life cycle inventory (LCI) studies. It does not describe the LCA technique in detail, nor does it specify methodologies for the individual phases of the LCA.

ISO 14044: Environmental management - Life Cycle assessment – Requirements

It specifies requirements and provides guidelines for life cycle assessment (LCA) including: definition of the goal and scope, the life cycle inventory analysis (LCI) phase, the life cycle

⁵⁰GHGs include among others carbon dioxide (CO₂), methane (CH₄), nitrous oxide (N₂O), hydrofluorocarbons (HFCs), perfluorocarbons (PFCs) and sulphur hexafluoride (SF₆).

impact assessment (LCIA) phase, the life cycle interpretation phase, reporting and critical review, limitations, the relationship between the LCA phases, and conditions for use of value choices and optional elements.

ISO 14025: Environmental labels and declarations - Type III environmental declarations - Principles and procedures

It establishes the principles and specifies the procedures for developing Type III environmental declaration programmes and Type III environmental declarations. Type III environmental declarations as described in ISO 14025:2006 are primarily intended for use in business-to-business communication, but their use in business-to-consumer communication under certain conditions is not precluded.

Ecological Footprint

The Ecological footprint (EF) standard was developed by Global Footprint Network. The EF provides measure of the extent to which human activities exceed biocapacity. Specifically, the EF integrates the area required for the production of crops, forest products and animal products, the area required to sequester atmospheric CO₂ emissions dominantly caused by fossil fuel combustion, and the equivalent area estimated to be required by nuclear energy demand.

Product and Supply Chain Standards Greenhouse Gas Protocol (WRI/ WBCSD)

The World Resources Institute (WRI) and the World Business Council on Sustainable Development (WBCSD) started to develop their Product and Supply Value Chain GHG Accounting and Reporting Standard in September 2008. The GHG Protocol Corporate Standard provides standards and guidance for companies and other types of organizations preparing a GHG emissions inventory. It covers the accounting and reporting of the six greenhouse gases covered by the Kyoto Protocol—carbon dioxide (CO₂), methane (CH₄), nitrous oxide (N₂O), hydrofluorocarbons (HFCs), perfluorocarbons (PFCs), and sulphur hexafluoride (SF₆). The Product Standard builds upon the ISO 14040 series of standards.

19.3. Carbon footprint, Life Cycle Analysis (LCA) for leather

Carbon Footprint definition:

A carbon footprint is the total amount of CO₂ and other greenhouse gases, emitted over the full life cycle of a process or a product (e.g. leather); it is expressed in grams of CO₂ equivalents.

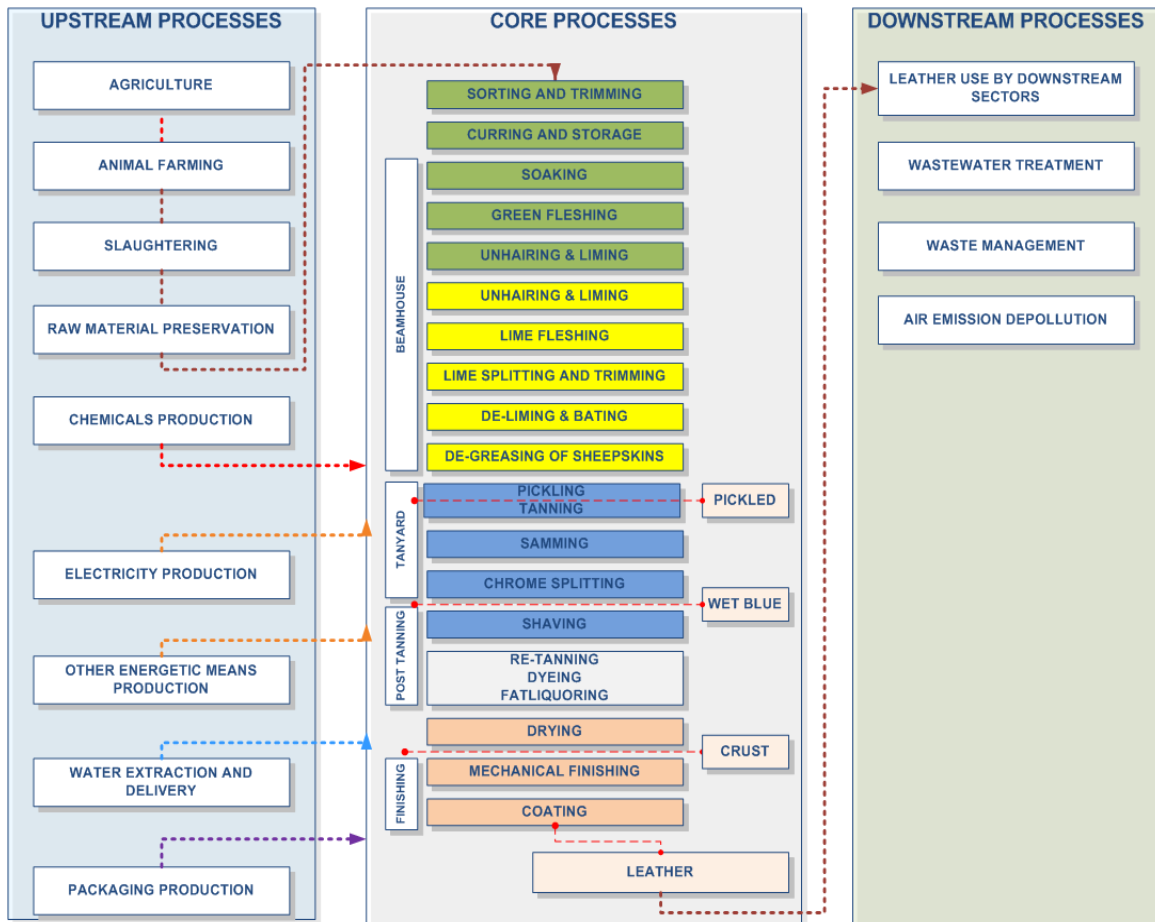

Figure 86. Overview leather processing – UNIDO/LCA Brugnoli

The CF for leather includes material and operations from the raw material starting from slaughterhouse to the end of leather product life cycle. The issue of boundaries is crucial.

In principle, cleaner and more efficient technologies are very important for the reduction of CO₂ emissions; however, there are also other factors which significantly influence the total leather CF, among them being mainly the following:

- i. Transport
- ii. Water consumption
- iii. Efficiency in use
- iv. Energy footprint
- v. Nature of raw material
- vi. Biodegradability
- vii. Use/recyclability

At the moment there is still not an agreed methodology for a CF calculation. There are several initiatives (e.g. COTANCE project) and it is hoped that they will provide data for more accurate estimations of the contribution of each step to CF emission, benchmarking and also a possible scope for reduction.

19.4. Overview of some contributors to CO₂ emissions in leather processing

19.4.1. CO₂ emissions from raw material transport

The two main factors here are:

- i. The means of transportation
- ii. Distance

Globalization makes it easy to send goods around the world. The cost for shipping goods has never been as low as now. However, the choice of the means of transportation and distance severely influences the amount of CO₂ emitted due to the transportation of goods.

Table 52. The amount of CO₂ (in grams) emitted per metric ton of freight & km of transportation

Air plane (air cargo), average Cargo B747	500 g
Modern lorry or truck	60 - 150 g
Modern train	30 - 100 g
Modern ship (sea freight)	10 - 40 g
Airship (Zeppelin, Cargolifter) as planned	55 g

The means of transport chosen to a large extent depends on the country of origin, destination and the infrastructure available. From that point of view, ideally, tanneries should be near the source of raw material whenever possible; obviously, this would also help avoid the negative impact of (long-term) preservation.

19.4.2. Energy and CO₂ emissions

In the case of liquid fuel used for the preparation of hot water, the emission is approx. 3 kg CO₂/l of combusted fuel. Thus, for example, the CO₂ emissions for a tannery with a daily input of 10 tons of w.s. hides are as follows:

Liquid fuel emission kg CO ₂ /l	Liquid fuel l/t of raw hide	CO ₂ emission		
		kg CO ₂ /t of raw hide	kg CO ₂ /d	kg CO ₂ /y
3	230	690	6900	2518000

The CO₂ emissions related to electric energy consumption depend on the primary source (or the source mix) of the electric energy, which is very different for different countries.

According to Poncet⁵¹, for example, for the source mix in France consisting of 80% nuclear energy, 10% fossil energy and of 10% from renewable resources (mainly hydroelectric) the emission is 0.059 kg CO₂/kWh.

⁵¹ Poncet

If some thermal energy saving, using solar energy instead of the fuel is installed, the CO₂ emission decreases proportionally. Using self-produced electric energy from photovoltaic cells and wind, the direct CO₂ emission would be practically zero. CO₂ emissions for different energy sources are presented in the next table.

Table 53. Carbon dioxide emissions for energy from different sources

Source	CO ₂ emission, Kg/m ²
Coal	2.14
Liquid fuel	1.51
Gas	1.28
Photovoltaic	0.14
Wind	0.11
Nuclear	0.01
Hydro	0.007

The ways and means to reduce energy consumption are described in more detail in the chapter on energy; below are only a few important points:

- i. Use of efficient equipment (e.g. low speed drums)
- ii. Green fleshing
- iii. Splitting in lime
- iv. Use of natural light

As CO₂ emissions depend on the source of electrical energy (fossil, renewable etc.), this should be taken into consideration. In some regions a customer/tannery can choose the supplier and the source of energy. However in many countries, especially in developing countries, a tannery has no influence whatsoever on this important factor, although, for example, emissions from fossil fuels can be 40 times higher than from a hydroelectric source.

Table 54. Summary of Lifecycle of GHG emissions intensity for various electricity generation sources

Technology	Mean	Low	High
	grams CO ₂ e/kWh		
Lignite	1,054	790	1,372
Coal	888	756	1,310
Oil	733	547	935
Natural Gas	499	362	891
Solar PV	85	13	731
Biomass	45	10	101
Nuclear	29	2	130
Hydroelectric	26	2	237
Wind	26	6	124

Source: WNA, Comparison of Lifecycle Greenhouse Gas Emissions of Various Electricity Sources, 2011

19.4.3. Thermal energy

Most of the thermal energy in a tannery is needed for water heating and, in temperate climates, for the heating of the premises. Usually it is provided by a central boiler, the fuel used having significant impact on the level of CO₂ emissions.

Table 55. The amount of CO₂ emitted per GJ of energy for various fuels

Source	kg of CO ₂ /GJ
Coal (anthracite)	109.3
Coal (bituminous)	98.3
Coal (lignite)	102.9
Coal (subbituminous)	102.4
Diesel fuel & heating oil	77.1
Gasoline	75.1
Propane	66.4
Natural gas	55.9

As in the case of electricity, CO₂ emissions depend not only on the type of source of fuel but also on the efficiency of the heating system and heat exchanger.

In countries with sufficient insolation, a very attractive (supplementary) source of energy can be a Solar Water Heating System (SWHS), which not only reduces CO₂ emissions but also the operational costs. That is why it is very attractive from both an economic and an environmental point of view.

19.4.4. Waste Water Treatment⁵²

Effluent treatment with aerobic biological activated sludge treatment directly emits CO₂ in the atmosphere through the conversion of carbon contained in the organic matter in the waste water. This organic matter does not have a defined formula and differs from case to case. The content of the organic matter in the effluent is expressed as COD, or BOD₅. The content of organic carbon in effluent is expressed as Total Organic Carbon (TOC). The relation of the TOC to COD is approx. 1 : 3, and BOD₅ approx. 1 : 1.4, and the TOC calculated from the accepted value before biological treatment for COD (60 kg COD/t of raw hides) is:

$$\frac{COD}{3} = \frac{60}{3} = 20 \text{ kg C / t of raw hide,}$$

or calculated from accepted value for BOD₅ (25 kg BOD₅/ t of raw hide) is

$$\frac{BOD_5}{1.4} = \frac{25}{1.4} = 18 \text{ kg C / t of raw hide.}$$

The mean value is 19 kg of the organic C/t of raw hide. The equivalent value of the CO₂ to C is 3.67.

⁵² Contribution by M. Bosnić

According to these values, the quantity of the CO₂ emitted from the biological treatment due to conversion/oxidation of the organic matter is approx. $19 \times 3.67 = 70$ kg CO₂/t of raw hides (or, about 700 kg CO₂/d, or 255.5 t CO₂/y for a tannery with a daily input of 10 tons of w.s. hides).

The anaerobic waste water treatment produces biogas (methane, not CO₂), but due to later combustion of methane, ultimately CO₂ will be emitted.

Evidently, consumption of electric energy in the course of effluent treatment is (indirectly) a cause of CO₂ emissions.

Under the same conditions valid for the tannery, the CO₂ emissions from the (C)ETP operations are:

$$185 \times 0.059 = \mathbf{11 \text{ kg CO}_2/\text{t of w.s. hide}}$$

The total CO₂ emissions, direct and indirect, are: $70 + 11 = \mathbf{81 \text{ kg CO}_2/\text{ton of w.s. hide}}$

It means that, for example, operations of a tannery with a daily input of 10 tons of w.s. hides is responsible for $700 + 110 = 810$ kg CO₂/day or $255.5 + 40 = 295.4$ t/year.

The direct CO₂ emission from production of electric energy from photovoltaic cells and wind is practically zero.

Solid waste

Disposal of solid wastes also contributes to CO₂ emissions allocated to leather and that is why it is important that all fractions of solid wastes are re-utilized whenever possible.

Table 56. Estimated CO₂ emissions from solid wastes in a well-managed solid waste disposal site

Waste	CO ₂ kg/t
Putrefied hides / skins	624
Raw trimmings	624
Salt	624
Hair (pasting)	373
Lime sludge	455
Lime splits	624
Fleshing	624
Wet blue trimmings	221
Chrome splitting (bovine)	221
Chrome shavings	221
El/crust shavings*	221
Buffing dust*	221
Dyed trimmings*	221
Sludge (35% dry matter)	455

It is estimated that yearly CO₂ emissions from solid wastes decay can be 10-20 times higher than those from a properly designed and managed landfill disposal sites.

19.4.5. Product use and End of life (EoL)

CO₂ emissions during product life (shoes, leather goods, upholstery, etc.) is beyond the tanners' control.

Possible re-use of leather and/or incineration can be considered. In most cases it is disposed

Product life span should be taken into consideration when leather is compared with other materials.

19.5. Case study, Bangladesh: Solar Water Heating System in a tannery

The results of the operations and impact of the Solar Water Heating System, SWHS in Dhaka, Bangladesh):

Performance/energy produced per day: 18 – 30 MJ/m².

One square metre of the solar panel reduces carbon footprint by 5 – 8.3 kg CO₂/ day.

19.6. Analysis and recommendations (Brugnoli, UNIDO 2012)

- The ten hottest years on record have all occurred since 1998. Eighteen out of the last 21 years are among the 20 warmest years since 1880. The common conclusion is that the long-term trend is one of global warming.
- The increase in global average temperature since the mid-20th century is very likely due to the rise in anthropogenic greenhouse gas concentrations, specifically Carbon Dioxide, CO₂.
- It is estimated that industry and manufacturing contribute for 19% of all GHG emissions.
- The total amount of GHG produced during various stages in the life cycles of products is referred to as Product Carbon Footprints (PCFs).
- The Carbon Product Footprint (CFP) is defined as the “weighted sum of greenhouse gas emissions and greenhouse gas removals of a process, a system of processes or a product system, expressed in CO₂ equivalents” referring to a product system.
- The aim of the technical report is to provide a robust overview of publications, standards and papers relevant for the calculation of the Product Carbon Footprint of the product “Finished Leather” with recommendations for harmonization related to the main elements needed to define system boundaries.
- In the case of finished leather, the carbon footprint should obviously be expressed as: **Kg of CO_{2e}/m² of finished leather.**

- Currently, there is no single methodology and no agreement has been reached internationally on Leather PCF calculation methods.
- The inherent complexity and lack of exactness of carbon footprint analyses contrasts with the need to communicate the results in a simple, clear and unambiguous way.
- After analysing other options/methodologies, ultimately for our case the following were adopted:
 - Carbon Footprint of Products : ISO DIS 14067
 - Life Cycle Assessment: ISO 14040/44)
 - Environmental Labels and Declarations: ISO 14025
- Similarly, to ensure a common approach to be followed in future activities the following aspects are of particular importance:

❖ **Functional unit**

Used in LCA and CFP analyses to provide a reference to which environmental impacts are related; it should be consistently measurable and correspond to the basic unit used in the trade. The recommendation is to use **1 m² of finished leather**, including an indication of the thickness of the material.

❖ **System boundaries:**

It is important to recognize the implications of the different conceptual approaches to raw hides and skins as raw materials for the tanning industry: in particular, whether they are to be considered as a waste, as a by-product or as a co-product of the milk and meat industry. If the raw hides and skins are considered as waste of the milk and meat industry, the whole environmental impact (and therefore of the CO₂ equivalent content) has to be allocated to the main product of the economic value chain (i.e. milk and meat). This implies that agriculture and animal farming, as processes of the upstream module, shall be excluded from the System Boundaries of LCA studies on leather.

In the case that raw hides are considered as a by-product or co-product of the milk and meat industry, some may argue that part of the environmental impacts (and therefore of the CO₂ equivalent content) have to be allocated to the co-product itself, on the basis of different allocation criteria. Accordingly, for raw hides and skins coming from animals raised mainly for human feeding purposes, such as milk and meat production (and therefore, bovines, sheep, goats and some other), the system boundaries are to start in the slaughterhouse.

❖ **Quantification**

The different approaches reviewed show a certain similarity, converging in the subdivision of leather production in individual processes and quantifying the emissions from each process. The harmonized methodology proposed, in order to obtain Kg of CO_{2e}/m² of finished leather, lies in the quantification of CO_{2e} content of all the different products and material entering the tannery (UPSTREAM PROCESSES), adding CO_{2e} produced in the tannery itself (CORE PROCESSES), as well as CO_{2e} emanating from water and air purification and waste recycling/disposal (DOWNSTREAM PROCESSES).

❖ Allocation

Choosing an allocation rule conditions the environmental impact distribution between economic actors from the same value chain. Economic allocation seems to be rather vague due to factors contributing to it (market price of raw hides, value of the animals during their lifespan) and it should be avoided whenever possible; if unavoidable, the allocation should be made according to the physical relationship within the single process under consideration.

It would be necessary to set up a specific working group, involving participants in the processes within the system boundaries such as slaughterhouses, chemicals producers, suppliers of energy and water, tanneries and effluent and waste treatment plants. They should possess the competence concerning:

- Harmonised Product Category Rules for LCA and PCF of Leather, including the conclusions of the present report
- Life Cycle Inventory (compilation and quantification of inputs and outputs for processes within the leather system boundaries) at pilot scale, including needed key actors
- Practical guidelines for LCA and PCF calculations, deriving from the Life Cycle inventory work
- Harmonised data quality and calculation requirements along the value chain

Finally, it is recognized that at the moment the LCA – Carbon Footprint topic is primarily of interest to tanners in industrialized, especially EU countries; however it is felt that also those in BRIC and even Least Developed Countries should be aware of the current environmental impact assessment and protection trends and be ready to apply them at the appropriate time as needed. It is hoped that in the meantime better standardized methodologies and probably some blueprints will also be made available.

19.7. Supplementary information from various sources

19.7.1. System expansions to handle co-products of renewable materials

B. P. Weidema, Institute for Product Development, Denmark, LCA Case Studies Symposium SETAC-Europe, 1999

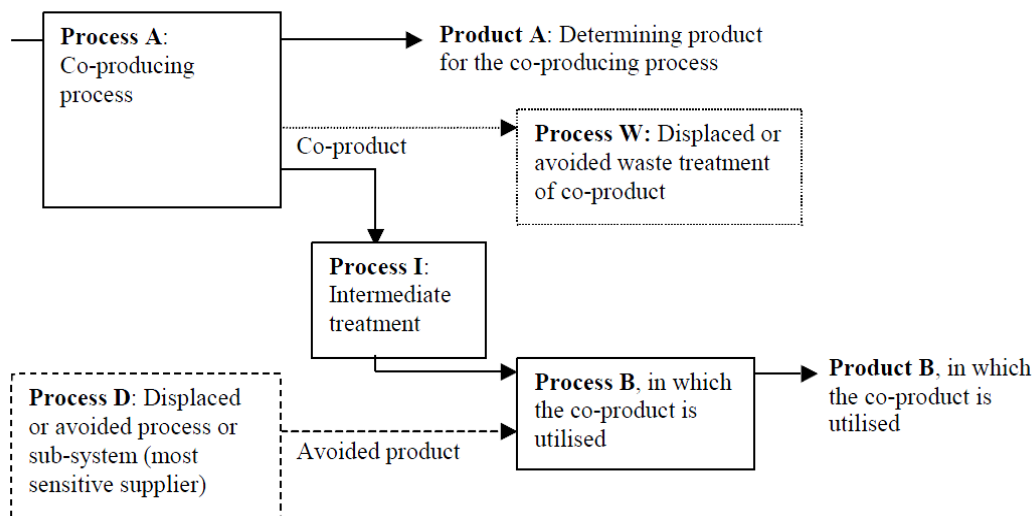

Figure 87. Model for describing system expansion and delimitation in relation to co-production

1) The co-producing process shall be ascribed fully (100%) to the determining product for this process (product A).

2) Under the conditions that the non-determining co-products are fully utilised in other processes and actually displaces other products there, product A shall be credited for the processes, which are displaced by the other co-products, while the intermediate treatment (and other possible changes in the further life cycles in which the co-products are used, which are a consequence of differences in the co-products and the displaced products) shall be ascribed to product A.

If the two conditions stated in rule No. 2 are not fulfilled, rule No. 3 and 4 apply, respectively.

3) When a non-determining co-product is not utilised fully (i.e. when part of it must be regarded as waste), but at least partly displaces another product, the intermediate treatment shall be ascribed to product B, while product B is credited for the avoided waste treatment of the co-product.

4) When a non-determining co-product is not displacing other products, all processes in the entire life cycle of the co-product shall be fully ascribed to product A.

19.7.2. BASF (China), September 2014

- ✓ The impact/reduction of leather weight/thickness on CO₂ emissions from car upholstery is insignificant
- ✓ Corporate Carbon Footprint, CCF (Knoedler) of finished leather in cars is estimated at 1.4 – 6.4 kg of CO₂/m² of finished leather (without chemicals, breeding and ultimate leather disposal after use)
- ✓ The higher the complexity of the chemical, the higher the CO₂ emission
- ✓ Accordingly, the main impact is from retannage, minor from the beamhouse and finishing
- ✓ Powdered products are higher in CO₂ emissions than liquid

19.7.3. Eco-Design: Life Cycle analyses show that energy is a key factor for the environmental impact of leather and might save money, T. Poncet et al., XXXI IULTCS, Valencia

When considering the important criteria that characterises the environmental impact of leather (“eco-leather”), energy is a key issue for:

- abiotic depletion,
- greenhouse effect,
- acidification,
- photochemical pollution.

The chart below shows the relative part of CO₂ emissions due to energy for the production of leather through a life cycle analysis. It takes into account energy of the tannery, the production of chemicals used in the tannery and transportation.

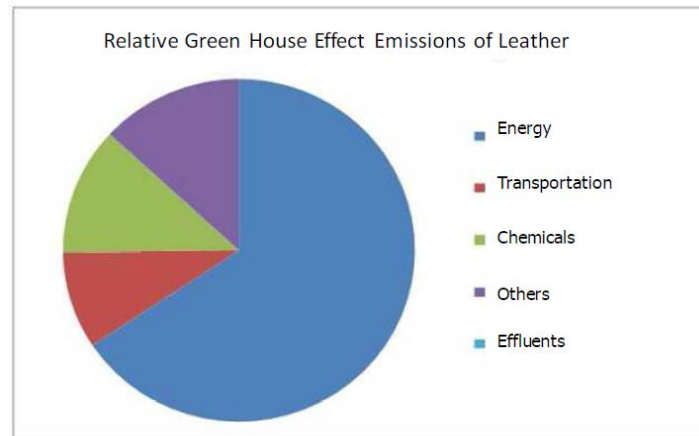

19.7.4. BLC

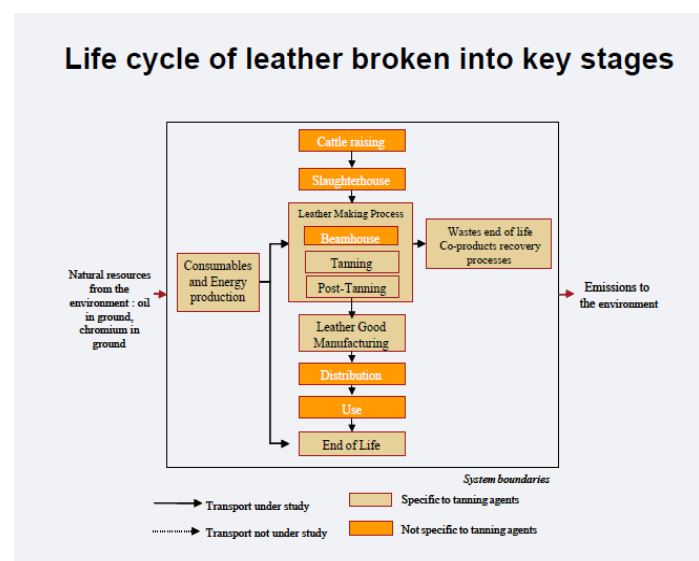

The complication for leather is whether the calculation aims to allocate a proportion of the footprint from the raising of the animals from which the hides and skins arise. If this aspect is included in the footprint for leather, it has been calculated that animal raising represents around 85% of the total footprint for leather production.

An important contribution to this discussion is the recent UNIDO report “Life Cycle Assessment, Carbon Footprint in Leather Processing”. A key issue in the report is the “system boundary” or where the line is drawn around the process. The report adopts the concept of the “determining product” which says that the product that determines the volume of production should bear the carbon footprint.

In the case of leather, the consequence of applying this concept is that since animals are raised essentially for meat or milk, and not for the hide or skin, then the calculation of the carbon footprint for leather should start at the abattoir, where the hide is first produced as a separate product.

It is expected that this debate will continue within the leather sector.

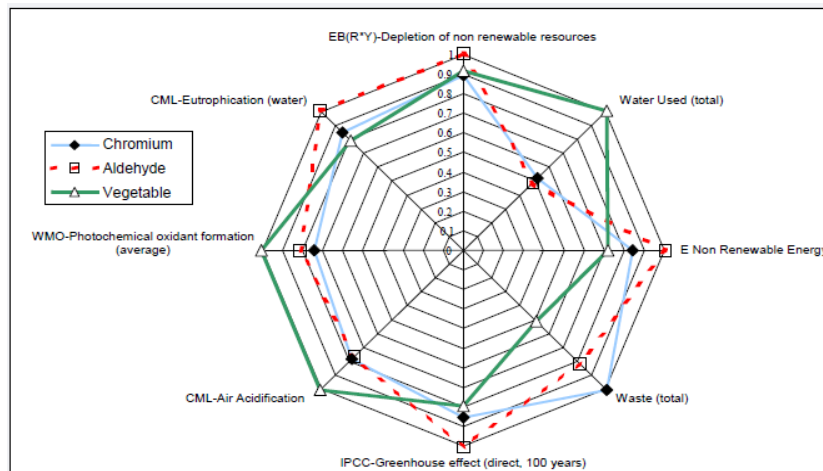

Figure 88. Baseline results for each tanning technology, general LCA impacts⁵³

What is the most environmentally advantageous tannage (chrome, vegetable, aldehyde)?⁵⁴
 There is no clear answer; each has specific environmental strength. What happens to shoes, sofas and wallets when thrown away?

- Post tanning operations have the major influence on the overall impact
- Aldehyde and chromium very similar in terms of environmental impact
- Vegetable tanning shows strengths and weaknesses compared to both chrome and aldehyde tanning
- End of life has an impact in terms of landfill (?)
- Advantages and disadvantages of all three

End of life:

- Incineration (chrome III to VI)
- Landfill (the risk of leaching)
- Gasification
- Biofuels⁵⁵
- Composting

The share of tanning methods, worldwide

Chrome	80%
Vegetable	15 – 18%
Chrome free	2 – 5%

Stability, in descending order⁵⁶

Vegetable
Chrome
Chrome free
Chamois (easily degraded, small share)

⁵³The logic here appears quite arbitrary! Cr consumption used for tanning purposes is only a fraction of the total (metallurgy!).

⁵⁴Right in the sense that the nature of pollution of post tanning (hard to treat) is normally underestimated! Otherwise, conclusions are rather inconclusive!

⁵⁵Unrealistic, at least for the time being. The same applies to composting.

⁵⁶Vegetable tanned leather is stable only if kept dry, not humidity resistant!! Compare with LGR study (Cr vs. vegetable).

A good definition of CF:

A carbon footprint is the total amount of CO₂ and other greenhouse gases, emitted over the full life cycle of a process or a product. It is expressed in grams of CO₂ equivalents.

Other greenhouse gases (GHG)⁵⁷

It is often overlooked that in addition to carbon dioxide, CO₂ there are other greenhouse gases as well as ozone depleting substances.

	Greenhouse gas	Chemical formula	100 year GWP
	Carbon dioxide	CO ₂	1
	Sulphur hexafluoride	SF ₆	22800
	Methane	CH ₄	25
	Nitrous oxide	N ₂ O	298
some HFCs	HFC-23	CHF ₃	14800
	HFC-32	CH ₂ F ₂	675
	HFC-236fa	CF ₃ CH ₂ CF ₃	9810
some PFCs	PFC-14	CF ₄	7390
	PFC-116	C ₂ F ₆	12200

Source: IPCC

Methane production: 550 – 700 litres/cow/day. Methane is about 25 times worse than CO₂!

When considering CF it is important to take into account not only direct emissions from production but also emissions from electricity/power as well as indirect ones from products and services used (e.g. transportation).

To reduce the carbon footprint consider:

- Sourcing and manufacturing
- Transportation (e.g. by surface instead by air)
- Optimisation of energy efficiency and use of renewable (solar energy) and non-traditional sources (heat pumps)

19.7.5. UK, Environmental Reporting Guidelines, mandatory GHG emissions reporting guidance, June 2013

The Companies Act 2006 Regulations 2013 requires quoted companies to report on greenhouse gas (GHG) emissions for which they are responsible. Quoted companies, as defined by the Companies Act 2006, are also required to report on environmental matters to the extent it is necessary for an understanding of the company's business within their Annual Report, including where appropriate the use of key performance indicators (KPIs). If the Annual Report does not contain this information, then it must point out the omissions.

⁵⁷Incidentally, it is quite amazing to read dramatic, pessimistic forecasts of rapidly approaching draining of world oil reserves of some 20 years ago!!

19.7.6. Footprint boundaries for Leather, D. Tegtmeier, IUR Commission, IULTCS

- ✓ An official LCA method for products based on renewable materials was applied on the leather manufacturing process in order to harmonize the calculations and determine a reference standard.
- ✓ Unfortunately, the boundary setting for a system to calculate the environmental footprint is not simple; very different methods refer to different system boundaries.
- ✓ In regards to leather, the big issue is whether to include or exclude the upstream processes such as the breeding of animals as well as the agriculture for growing the respective feed.

Carbon and Water Footprints are becoming important KPI's for the climate and energy impact of an article

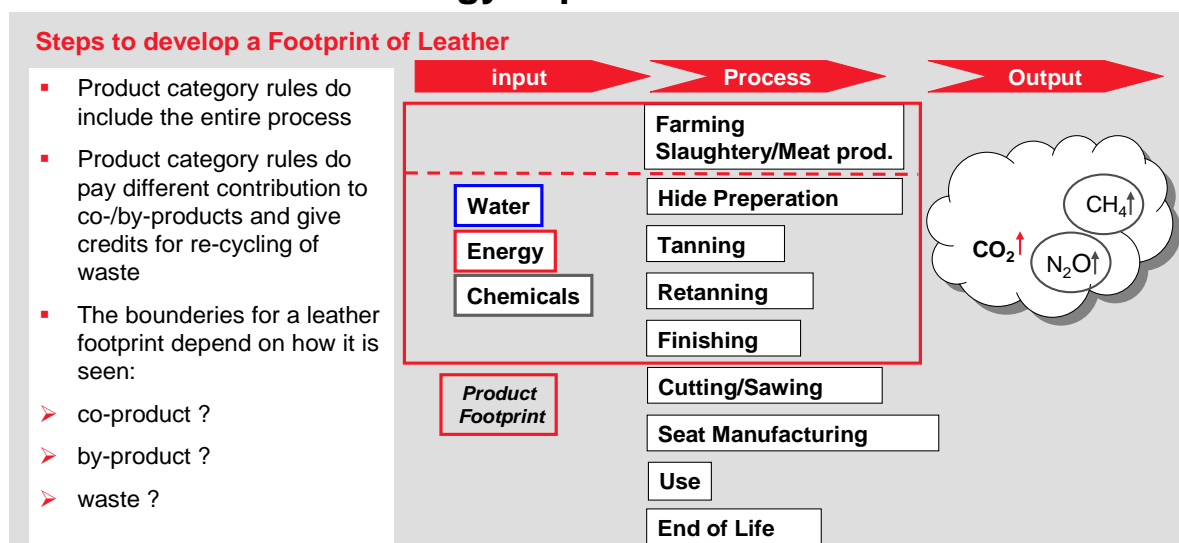

Figure 89. Process chain of leather manufacturing

The LCA methodology proposed by B. Weidema (1999) and based on scientific justification is the most appropriate for leather manufacturing.

From a LCA point of view, while meat and milk are the main products, hides and skins can be classified in three categories

➤ **Co-product**

Has a significant value and cannot be seen independently from the main product; footprint values get shared according to reasonable economic value contributions.

➤ **By-product**

A by-product is still a useful outcome of the main process, however use and application has no influence on the production of the main product. It is considered to be a "non-determining co-product". For a footprint calculation normally a partial contribution could be done; however, exceptions are possible but need to be clearly justified.

➤ Waste

Waste is “left over” with no-to-low value and also zero influence on the main stream product, which should go to a re-cycling operation or an appropriate disposal. The footprint impact of the treatment will be allocated to the main product.

Leather is generally seen as a by-product of the meat or milk industry.

Recent studies have shown that the carbon footprint of leather can vary between 35 and 320 kg/m² for the same article depending on how boundaries are set and what parameters should be taken as a base for the calculation.

Only a very small contribution appears to be allocated to the tannery operation (see fig: 2). In terms of a carbon footprint of 110 kg/m² (average value) it is less than 20%, in terms of a water footprint of 16.500 l/ m² and it is even less than 1 % of the overall sum.

Water- and Carbon Footprint contribution for Leather of a tannery operation is insignificant small

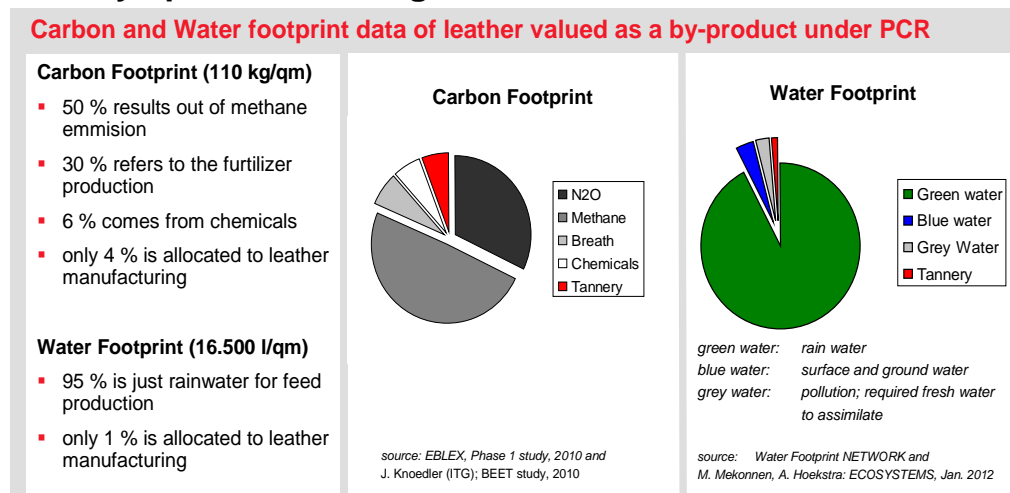

Figure 90. Examples for Water- and Carbon footprint splits based on traditional product category rules (PCR)

Allocation shall be avoided whenever possible.

A simple and logical methodology with extended boundaries (System Expansion) is the alternative which should be applied for certain products originating from renewable sources and generating several co- or by-products, in other terms “sustainable materials”. The leather manufacturing process fits well to this method, the main conditions of which are:

1. the co-product/by-product needs to be based on a renewable raw material source
2. the co-product/by-product should displace in its final application another product based on a non-renewable material
3. the demand for the co-product/by-product has no influence on the production volume of the main product

For leather all the three conditions are 100% valid:

Ad 1) The overall average use of a leather article estimated at approximately 4 years (upholstery ~10 years, shoe ~1 year, leather goods and garments ~ 4 years) is very much in balance with the reproduction time of a hide or skin.

Ad 2) Leather is a widely used material for prime consumer articles such as shoes, furniture seating, garment, automotive seats, etc. If leather wouldn't be available as a choice of material, the same amount of articles would be produced with alternative substrates. A high amount of them would be based on non-renewable materials such as PU coated substrates or vinyl; these products are actually being displaced by the use of leather. Their avoidance is a benefit for the environment; the corresponding carbon emissions have been avoided because of the valorisation of animal hides and skins into leather.

Ad 3) The meat and milk production are the main upstream processes; in some cases for footprint calculations even the agriculture for the animal food is incorporated. The volume of the main products is in NO way determined by the demand for leather. Over the last 10 years due to special feedlot practice animal weight gets significantly increased, which leads to a lower amount of available hides based on a similar meat production.

This methodology fits well for environmental footprint calculations of leather products, regardless of whether it is the water footprint or the carbon footprint. In all cases animal raising and agriculture are excluded and the footprint calculation starts in the slaughterhouse with zero.

In order to encourage the use of by-products for sustainable application, when they displace materials based on non-renewable raw materials, extended system boundaries will be applied even for the upstream processes. The upstream process gets the credit, in case this by-product is used according to the rules for a sustainable product, so that it will have no impact – it is carbon neutral. Thus, for a hide or skin converted into leather, the meat industry is credited for the corresponding CO₂ emissions avoided by the displaced products.

For by-products, which are generated along the leather manufacturing process applies the same logic; if they are again used as a raw material for a new application, even the leather making process gets credited accordingly. It remains to be clarified whether the contribution of the by-product is evaluated on weight or on value.

19.7.7. J. Knoedler, ITG, Germany

- ✓ Artificial leather: 15.8 kg CO₂e/m² (including incineration)
- ✓ Textile (polyester): 20.6 kg CO₂e/m² (including incineration)

The basic premises regarding CFP in the tanning industry:

No leather processing/no tanning industry → the cattle livestock not affected
 Reduced meat/milk demand & production → reduced cattle livestock

ergo

Animal raising not related to the leather industry! → CO₂ emissions from cattle farming belong to the meat/milk industry!

CO₂e/m² in the tanning process:

- Transport of raw material and chemicals 0.6 kg CO₂e/m²
- Processing from raw hide to finish 2.5 CO₂e/m²
- Waste water treatment, incl. transportation 0.3 CO₂e/m²

Figure 91. Carbon dioxide, CO₂e/m² of leather

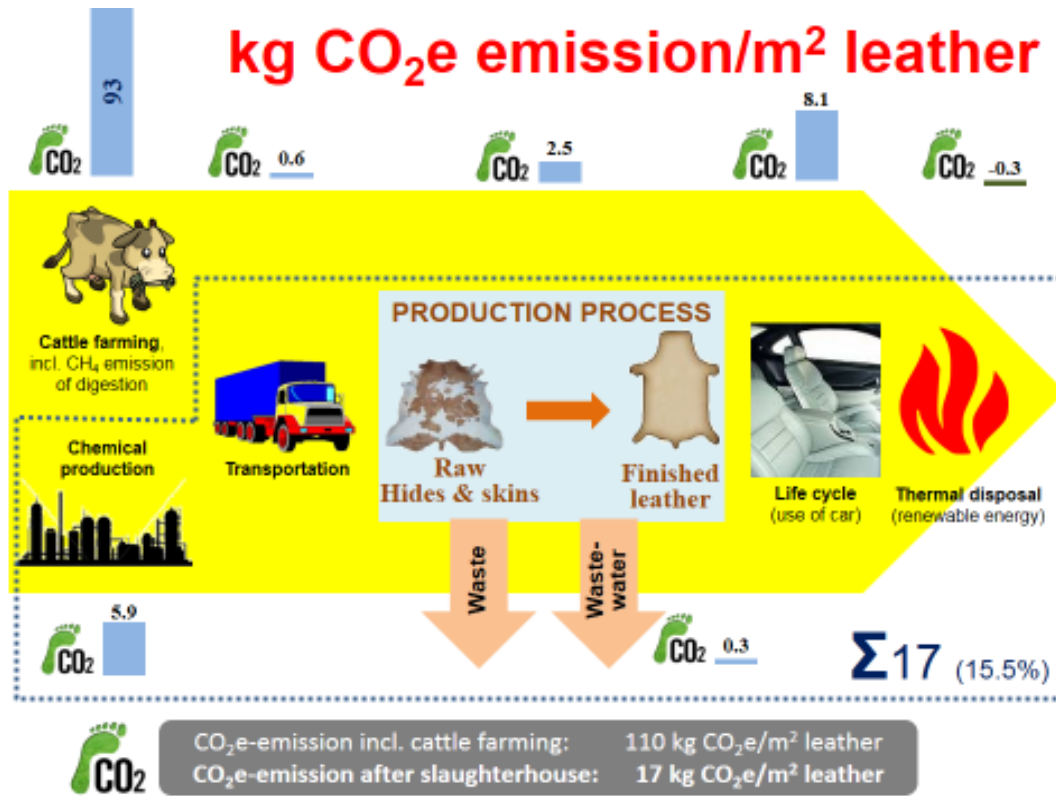

The chart by F. Schmel, derived from the presentation by J. Knoedler

- ✓ CO₂e emissions including cattle farming: 110 kg CO₂e/m² of leather
- ✓ CO₂e emissions after slaughterhouse: 17 kg CO₂e/m² of leather

CO₂e emissions and PCF for leather for car upholstery, “cradle-to-grave”, from slaughterhouse:

Life cycle car	45.3%
Production	14.0%
Chemicals	36.5%
Waste and waste water treatment	1.7%
Employee access route	0.4%
Final thermal disposal	1.1%
Transportation	1.7%

UNIDO Shanghai 2012, system boundaries, three preconditions:

- The material (raw hide) needs to be fully based on a renewable raw material
- Should at least partly replace a non-renewable substrate in its final application
- The demand for the product does not influence the upstream process

If all three conditions are fulfilled the boundary for the co-products (leather) should exclude upstream processes because it is a sustainable material.

19.7.8. End of life (EoL), UNIDO 2014

Leather is nowadays mainly used for footwear production, automotive & furniture upholstery, garments, gloves and other leather goods production.

The footwear industry over the last years has placed significant effort in improving energy and material efficiency, as well as eliminating the use of hazardous materials during the production phase. However, the environmental gains and energy efficiency made in production are being overtaken by the considerable increase in the demand for footwear products, the so called rebound effect. Moreover, the useful life of shoes is relatively short and progressively decreasing as a result of rapid market changes and consumer fashion trends. This creates a large waste stream of worn and discarded shoes at the time their functional life has ended most of them are being disposed of in landfills. Producers' responsibility issues and forthcoming environmental legislations, as well as increasingly environmental consumer demands, are expected to challenge the way the footwear industry deals with the EoL of its products.

Currently around 19 billion pairs of leather shoes are produced worldwide every year, and this figure continues to rise. This creates an enormous amount of post-consumer (end-of-life) shoe waste that is currently being disposed of in landfill sites around the world. The footwear industry, over the last years, has placed significant effort in improving energy and material efficiency. Producers' responsibility issues and forthcoming legislation as well as increasing environmental consumer demands are expected to challenge the way the global footwear industry deals with its end-of-life waste.

19.8 Producer's responsibility issues

In most countries, managing EoL waste has long been and, in most cases, still is the responsibility of governmental agencies and local authorities. Once products reach the end of their functional lives, producers play no role in collection, recycling and/or disposal of EoL products.

This approach has started to change with the emergence of a producer's responsibility concept. This concept was first introduced in Germany with the 1991 Packaging Ordinance which required manufacturers and distributors to take back packaging from consumers and ensured that a specified percentage is recycled. Producer responsibility legislation was introduced into the EU waste policy with the 1994 Packaging Directive and since then has spread to most industrialized countries. In 2000, the European Commission passed a Directive requiring its Member States to institute a producer responsibility program for end-of-life vehicles (ELV) which also includes leather used in cars and vehicles.

This concept of broadening a manufacturer's responsibility for products beyond their useful life and into the post-consumer phase includes closing the loop concerning materials used and waste management. This approach should provide a source of financing to offset the cost disadvantage of recycling versus disposal and energy recovery.

In this context, take-back and producer responsibility legislation is expected to affect the footwear sector including leather, similarly to what has happened in the case of cars (ELV).

20. EMERGING TECHNOLOGIES

It is very likely that the trend of small- and medium- scale tanneries disappearing (unless operating in special niches) will continue, while the processing capacities of individual tanneries and/or systems will expand.

As a corollary of such developments it is certain that there will be further significant improvements and innovations in the automation of tanning processes and operations such as in-plant transfer of materials, weighing, mixing, dosing, heating, drying, etc. There is no doubt that new generations of machines will be more accurate, safer and easier to operate; noise and vibrations will probably be considerably reduced, etc.

However, without having a magic crystal ball it is very hard to make any predictions about possible changes of basic physical-chemical principles of leather tanning which have been with us for quite some time. In any case, at the moment nothing of that kind is clearly on the horizon.

Against that backdrop, below is an almost random selection of some more recent ideas and methods at various stages of research and development.

➤ **Enzymatic – oxidative unhairing**

While there is no significant progress in “pure” enzymatic unhairing and details about oxidative unhairing at the industrial scale are still not available, success is claimed in laboratory scale tests of enzymatic-oxidative hair-save unhairing of cow hides using a strain of *Bacillus subtilis* and hydrogen peroxide without any lime or sulphide and reducing the process to only about 4 hours.

➤ **Application of ultrasound in chrome tanning**

A combination of wringing and ultrasound in a two-step process (penetration and basification tank) is used to accelerate the chrome tanning process based on the mechanical extrusion formation of the micro-vacuum and ultrasonic cavitation effect.

➤ **Application of ultrasound in retanning**

The effect of an ultrasound (US) has been investigated in improving the penetration and uptake rate of different syntans (phenolic based, melamin resin, acrylic compound) in leather retanning and compared with magnetic stirring (MS). Favourable influence of pre-sonification of both the substrate (leather) and the syntan solution result in considerable improvement of diffusion rate, shorter processing time and better leather quality.

➤ **Inverse chrome tanning with wet-white pretanning**

The proposed process sequence is: bating, washing, white pretanning, sammying, shaving, weighing, re-wetting with acidification with formic acid, retanning (synthetic fatliquor/dispersing syntan/acrylic resin/mimosa, phenolic syntan, melamine resin/formic acid), fatliquoring (synthetic fatliquor, formic acid), drain, followed by the usual chrome tanning with basification (100% fresh float, 14% chrome powder). The main gains should

be chrome emissions limited to one process only and reduced by about 50% plus chrome-free shavings. There is no information about other pollutants (BD,COD, salts etc.)

➤ **A fresh attempt with Fe tannage**⁵⁸

One among various attempts in searching for alternatives to the prevailing tanning methods is tanning with Fe²⁺-gluconic acid compound, apparently still at the laboratory scale.

➤ **Collagen modification and nano technologies**

Some R & D establishments, in particular in Xian, China, have been searching for ways to depart from using traditional, chemicals based leather making methods. Instead, they are looking into various options for modifying collagen fibers by nano-size emulsions, clay minerals, nano silicon dioxide or nano silver and nano technologies in general.

➤ **Elimination of free formaldehyde with essential oil**

The conclusion of one study is that the release of free formaldehyde from tetrakis (hydroxymethyl) phosphonium (THP) salts and various syntan leather products can be suppressed by using *Origanum onites* essential oil.

➤ **Bioresistance by application of nanosilver**

A combination of the colloidal silver solution (CSS) and polyhydroxiurethanes is used to interact with collagen or keratin from medical leather and sheepskins to induce bioresistance properties against fungi as well as a good antibacterial action.

➤ **The ISO 17075 method for Cr⁶⁺ detection**

The ISO 17075 method for Cr⁶⁺ detection (at pH 8) systematically gives false positive values. Moreover, Solid Phase Extraction (SPE) cartridges absorb about 10% of chromate; thus the calibration curves should be obtained after filtering each standard with the SPE employed.

➤ **Artificial collagen**

The old idea of artificial collagen is now revisited under the EU basic research project for synthesizing collagen-like protein fibres and webs by using biotechnology.

➤ **Chromogenic leather**

There are already reports on tests with chromogenic leather, i.e. leather that changes colour in response to optical/thermal changes.

➤ **Biochemical degradation of chrome shavings**

There are new investigations into the scope of combined chemical and enzymatic degradation of chrome shavings and protein extraction.

➤ **Closed cycle dechroming of chrome shavings**

⁵⁸ *This attempt runs against the view that the search for a straight substitute for chromium (III) is futile because "...the periodic table holds little hope of discovery of new commercially useful tanning agents, based on elements not previously considered."* (Nursten)

Ethylen Diamine Tetraacetic Acid, EDTA is used for dechroming chrome shavings during extended processes involving heating, UV light (photocatalysis), chrome precipitation with NaOH and acidification with sulphuric acid. High chrome removal efficiency and preservation of the collagen triple helix are claimed in these mini-lab scale tests.

➤ **Highly biodegradable leather**

A success is claimed in developing an aldehyde based tanning system resulting in leather showing biodegradability four times higher than chrome tanned and two times higher than wet-white based leather. Full desintegration of leather under composting conditions according to ISO 20200:2004 was reportedly achieved within 11-14 days as well as of footwear made of biodegradable components and with uppers and linings of leather tanned by the new system within 21 days.

➤ **Composting**

A new attempt in composting tannery waste at the industrial scale is underway: dewatered sludge with dry matter content of 20-25%, fleshing and grease residues are mixed with shavings from vegetable tanning, grass and green farm residues. From time to time some quantities of cow and horse dung are added. Composting takes place in two-months cycles in windrows in a roofed area. It is reported that the Cr content is about 1500 mg/kg calculated on dry weight which is after mixing with other organics reduced to about 1000 mg/kg to be used as a nutrient and soil conditioning agent.

Note: According to regulations in some EU countries, it is necessary to maintain a temperature of 60°C (in a closed system) or 65°C (inside the piles) and fleshings must have come from healthy animals.

21. CONCLUSION

It is important, at the global scale, to accelerate implementation of best technologies currently available combined with efficient waste handling and treatment of tannery effluent. The next table gives a condensed overview of cleaner leather technology methods.

Equally important is better worldwide coordination of effort to oppose the perception of leather manufacture as a dirty, polluting industry. Emphasis on its recycling character and comparisons with some other sectors/products (blue jeans!) can be very helpful. Recent activities of several international and regional organizations are indeed on the right track.

Figure 92. A tannery or a pharmaceutical plant?

(The mezzanine in the wet finishing department in Dani Tannery, Italy)



Source: *World Leather*, June/July 2012

However, research and development centres, institutes, education and training centres and, in particular, public media in the leather sector should contribute to achieving this objective. A good example could be a better balanced approach and more careful wording when it comes to *chrome vs. chrome-free tanning*; poor science should not prevail over facts.

Practical experience to date shows that no metal tanning agent matches the versatility of chrome (III). Total chrome replacement is possible if reduced hydro-thermal stability and lower handling qualities are acceptable. However, most end-uses of leather require high hydro-thermal stability. For example, shoe upper leather must withstand hot lasting and heat setting, while garment leather must withstand steam pressing.

Table 57. Cleaner leather technologies at a glance

Category/Process stage		Cleaner methods
EMS		A licensed or own Environmental Management System, incorporating OSH and Corporate Social Responsibility (CSR) in place
General	<i>Water</i>	Strict water monitoring/control and savings measures at process, department and company level; batch washing, recycling
	<i>Energy</i>	Usual consumption/savings measures supplemented by obtaining the energy from renewable sources, heat pumps, etc.
	<i>RSL</i>	Apply the global strictest Restricted Substances and SVHC lists and avoid any limitations and risks in exports of leather and leather products
	<i>OSH</i>	Strict segregation of acidic and sulphide containing streams, H ₂ S monitors in place, staff trained
Noise, vibrations, malodour control; appropriate lighting and ventilation, sanitary facilities		
Occupational Safety and Health measures, general and personal (Personal Protection Equipment, PPE), including training rigorously implemented and observed		
Beamhouse	<i>Preservation/Soaking</i>	Use of green, non-salted hides Green fleshing Biodegradable surfactants Watch for harmful pesticides
	<i>Liming</i>	Hair-save liming Consider reuse of liming liquors Ex-lime splitting
	<i>Deliming</i>	Low- or ammonium-free deliming (CO ₂) deliming
	<i>Bating</i>	Low- or ammonium-free bating agents
Tanyard	<i>Pickling and (chrome) tanning</i>	Low-salt pickling Consider pre-tanning (wet white tanning) One or combination of better chrome management systems <ul style="list-style-type: none"> • optimization of process parameters • high exhaustion • direct recycling of spent bath • reuse after chrome recovery Use of acceptable fungicides
finishing	<i>Retanning</i>	Use of acceptable retanning agents (phenol- and formaldehyde-free)

Category/Process stage		Cleaner methods
		Use of low salt retanning agents High exhaustion rate Careful selection of auxiliary agents
	<i>Dyeing</i>	Avoidance of banned dyes Use of dedusted dyes High exhaustion rate Careful selection of auxiliary agents
	<i>Fatliquoring</i>	Strict avoidance of halogenated (AOX) products High exhaustion rate Careful selection of auxiliary agents
Finishing	<i>Coating</i>	Control of airborne particles/dust Use of water-based finishing systems Avoidance of harmful cross-linkers Avoidance of pigments containing banned/restricted metals Coating by advanced spraying equipment (airless, HVLP guns, scrubbers); curtain and roller coating
Solid waste		Consequent segregation of different waste categories, innovative approach in utilization and safe disposal
Effluent treatment		On-site pre-treatment and full scale (biological) on- or off-site treatment; compliance with local discharge norms.

In setting and presenting its cleaner technology targets, the tanning industry should be realistic and bear in mind that a tanner's genuine raw material is actually collagen and that the rest is, if not waste, a kind of undesirable burden.

Similarly, while it is essential to strive for better uptake of chemicals used in the process, it has to be accepted that in our processes we deal with organic, protein substrate and chemical reactions of specific types.

The next figure derived from practical experience and some educated projections indicates the presently achievable targets of reducing the pollution load (measured in terms of the traditional parameters such as BOD, COD, SS, Cr etc.) typical for conventional technology.

Figure 93. Decrease of pollution loads in waste water after introducing advanced technologies, %

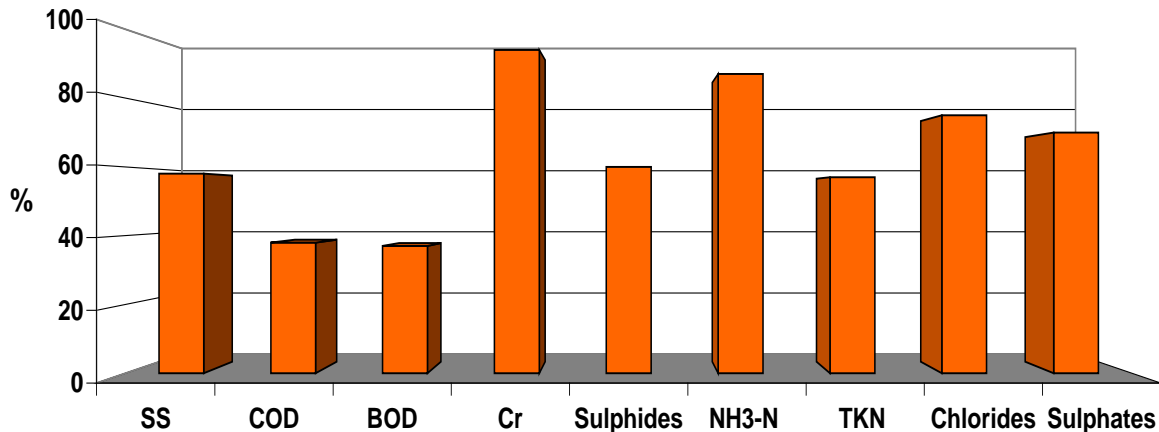

Chart by M. Bosnić

Obviously, given such a variety of raw material, types of leather(s) produced, specific local conditions, including climate, legislation, etc. each tannery and/or tannery clusters have to define their own strategies and ways and means of achieving them in close interaction with national and international R&D establishments and trade organizations.

In advanced industrialized countries, primarily in Europe, where the traditional pollution is well under control,⁵⁹ some other issues are coming more into focus.⁶⁰ The first is the question of use and presence of substances with proven and/or perceived long-term negative impact and thus placed on Restrictive Substances Lists (RSL). No tanner operating in the globalized market can afford not to be familiar with them and act accordingly.

The second issue is about Life Cycle Analysis (LCA) in practice appearing as the question of GHG or simply carbon dioxide and greenhouse effect.

The leather industry should persist in its view that leather manufacturing is actually a recycling industry using as its initial substrate waste generated by the food (meat) industry. In essence, leather making converts a renewable resource into a highly valuable, durable and safe material and thus provides employment of a significant scale in several downstream industries. Transformation of raw hides and skins into leather applying the Best Available Technologies (BAT) and following the highest environmental standards should ensure the position of leather as the preferred, sustainable material.

⁵⁹ Except hard to degrade, recalcitrant COD mainly emanating from retanning.

⁶⁰ In short, the bottom line of current trends is that obnoxious beamhouse (for centuries associated with tanning activities) being cleaned up, it is chemicals in wet and dry finishing and LCA coming into the limelight of green pressure groups.

Consumerism, short-termism vs. quality and durability

Is it not about time to consider a paradigm shift, a very different strategy - superior quality and durability, coinciding with the old principle *waste not want not* i.e. towards responsible and rational utilization of resources and sustainable development? Or will a suggestion that the same leather bag or briefcase be used for several years, a pair of shoes proudly worn for a few seasons in the best case bring nothing but a benign smile...

J. Buljan, JALCA, J.A. Wilson Memorial Lecture 2014

As shown earlier in this paper, tanners are convinced that the scope and the borders for the computation of carbon dioxide attributed leather are clear and indisputable and start at the exit gate of the slaughterhouse.

However, the mood in the tanning sector (and not in the tanning sector only) in developing countries about the whole LCA/CF concept is quite different.

Indeed, it seems that the view that human activities are responsible for the rapid increase of the GHG related climate changes gradually prevails. At the same time, it is hard to oppose the argument that the carbon footprint of a cluster of small- and medium-sized tanneries in a developing country is almost negligible in comparison with some other activities. Many among them feel that, for example, city and home lighting for celebrations, not to mention (unnecessary?) war operations make hair splitting about CF from some stages of leather processing irrelevant and irritating.

From that point of view, by now already old concept of UN Brundtland's Commission Report that there is the unity of environment and development, they cannot and should not be distinguished as separate entities; the two are inseparable and as relevant as ever.

REFERENCES

Selected UNIDO documents

1. *Mass balance in leather processing*, J. Buljan, G Reich, J. Ludvik, IULTCS Congress 1997
2. *Tanneries and the environment, A Technical Guide*, UNEP-UNIDO, 1991
3. *UNIDO Regional workshop on cleaner tanning technologies, Chennai, India, 1998*
4. *The scope for decreasing pollution load in leather processing*, J. Ludvik, 2000
5. *Hair-save unhairing methods in leather processing*, W. Frendrup, 2000
6. *Chrome balance in leather processing*, J. Ludvik, 2000
7. *Chrome management in the tanyard*, J. Ludvik, 2000
8. *Ecolabelling, environmental management and related activities*, W. Frendrup, 2001
9. *Benchmarking in the Tanning Industry*, J. Buljan, 2007
10. *Introduction to treatment of tannery effluents*, J. Buljan, 2011
11. *Hair-save liming*, J. Buljan, I. Kral, 2012
12. *Sources, detection and avoidance of hexavalent chromium in leather and leather products*, C. Hauber
13. *Pollutants in tannery effluents, Sources, description, environmental impact*, J. Buljan, I. Král, M. Bosnić, R. Daniels, 2013
14. *Occupational safety and health aspects of leather manufacture*, J. Buljan, A. Sahasranaman, J. Hannak, 1999
15. *Safety Handbook - How to Deal with Hydrogen Sulphide Gas in Tanneries & Effluent Treatment Plants*, J. Hannak, G. Jayaraj
16. *What is the future of (chrome) tanning, Meet in Africa 2000*, A.D. Covington, J. Buljan, T. Ramasami, B. Shi, D.G. Bailey, W. Frendrup
17. *Desalting of raw hides/skins and reuse of dusted salt in pickling operation*, S. Sampathkumar, M. Vishwanathan, 2002
18. *Selection of Equipment for Laboratories Monitoring Pollution in the Tanning Industry*, M. Aloy, (English, French, Spanish, Chinese), 2000
19. *Costs of tannery waste treatment*, J. Buljan, I. Kral, 2005
20. *Review of some EU normative documents and legislation and their relevance for the tanning industry in developing countries: Part I, Best Available Techniques Reference Document (BREF) Part II, Registration, Evaluation, Authorisation and Restriction of Chemicals (REACH)*, J. Buljan, 2010
21. *Energy savings in Bangladeshi tanneries through solar energy use and electrical performance improvement*, L.F. Cabeza, C. Sole, H.R. Ghosh, Ahasanuzzaman, M. A. Rahman, I. Kral

Other sources

22. *The Chemistry and Technology of Leather, Volume II, Types of Tannages*, Edited by F. O'Flaherty, W.T. Roddy, R.M. Lollar, 1978
23. *Fundamentals of leather manufacturing*, E. Heidemann, 1993
24. *Tehnologija kože i krzna*, H. Grgurić, T. Vuković, Ž. Bajza, 1985
25. *Some considerations about the problem of salinity of tannery effluents*, J. Buljan, LGR Tagung 2004
26. *The next 100 years of leather processing*, A.D. Covington, *Leather World*, Dec 2009
27. *Best Available Techniques Reference Document, BREF, EU*, 2013
28. *Ökologische Aspekte wichtiger Gerbverfahren (Eine vergleichende Betrachtung der Chromgerbung und chromfreier Gerbverfahren)*, G. Reich, 2000

29. *Untersuchungen zur Entstehung und Vermeidung Chromat in Leder*, C. Hauber, H.P. Germann, Leder und Häutemarkt, 1999
30. *Energieeinsatz in der Lederindustrie*, H. Pfisterer, *Bibliothek des Leders*, Band 9, 1986
31. *Eco-Design: Life Cycle analyses show that energy is a key factor for the environmental impact of leather and might save money*, T. Poncet et al. IULTCS Congress, 2011
32. *Leather Technician's Handbook*, J.H. Sharpouse, 1989
33. *New Challenges in Chrome-free Leathers: Development of Wet-bright Process*, A. Bacardit et al., JALCA 109, 2014
34. *Pocket Book for the Leather Technologist*, Fourth edition, BASF
35. C. Tysoe et al. Lanxess Deutschland GmbH, *World Leather* Oct/Nov 2011
36. J.R. Rao et al. A Polymer-Based Preservation, www.aaqtic.org.ar/congresos/china2009
37. *Development of an alternative low salt hide preservation using dehydrating agent (PEG), sanitizer and crude glycerol*, Mila Aldema Ramos, ALCA Convention 2014
38. *Green Solution for Salinity in Tannery Waste water: A Step Forward in Leather Processing*, S. Subramanian et al. JALCA 109, July 2014
39. *Microbial Keratinase and its Potential Application in the Management of Tannery Hair Waste*, A.S. Onyuka et al. JALCA 109, 2014
40. *Transposition of Chrome Tanning in leather Making*, C. Wu et al., JALCA 109, June 2014
41. *The formation of volatile organic compounds (VOC) and hexavalent chrome in chrome tanned leather*, S. Nagel, M.J. Saddington Schill + Seilacher, *World Leather* April/May 2010
42. www.eco2l-leather.com/en/guideline/
43. *Reducing the carbon footprint of leather*, B. Wegner, *World Leather* Dec 2014
44. A. N. de Carvalho, *The Portuguese Technological Centre for Leather Industry (CTIC)*, *World Leather*, Dec 2014
45. *Cyclic Dechroming Process for Chrome Shavings by Coordination Substitution Reaction and Photocatalysis*, Y. Tang et al., JALCA 109, Nov 2014
46. *World Leather*, recent years
47. IULTCS-IUE, 2008
48. JALCA, several issues of the e-zine version
49. Lanxess, www.lanxessleather.com
50. Knoedler, J. (2014). *Management of water-use in tanneries*. Retrieved July 14, 2014, from <http://www.nothinghide.org/LeatherFacts/Water: reduce, reuse, recycle/Summary>
51. Money C.A. (1999), *Clean technology challenges*. In: *Science and technology for leather into the next millennium*, Tata McGraw Hill Publishing Company, New Delhi, pp. 284-294.
52. Salazar, J. M., *Recycling chrome liquors*. *Leather International*, Nov/Dec, 2008, 38.
53. www.leatherworkinggroup.com, LWG Environmental Audit Protocol, Issue 6.0
54. www.rizzi.it
55. Vallero International s.r.l., www.tantechservices.com
56. www.carlessi.it
57. „Lederhauptstadt“ Reutlingen, *Olivenblätter* statt Chrom, M. Petersen, *Stuttgarter Zeitung*, Nov 2013