



UNITED NATIONS
INDUSTRIAL DEVELOPMENT ORGANIZATION

Inclusive and Sustainable Industrial Development Working Paper Series

WP 3 | 2021

INTERNATIONAL TRADE AND THE CIRCULAR ECONOMY IN LATIN AMERICA AND THE CARIBBEAN

DEPARTMENT OF POLICY, RESEARCH AND STATISTICS

WORKING PAPER 3/2021

International Trade and the Circular Economy in Latin America and the Caribbean

Nanno Mulder
ECLAC

Manuel Albaladejo
UNIDO

Macarena Mo
Consultant
KAS

Ximena Olmos
Consultant
ECLAC

Patricia Dante
Consultant
UNIDO

Paula Mirazo
UNIDO



UNITED NATIONS INDUSTRIAL DEVELOPMENT ORGANIZATION

Vienna, 2021

Acknowledgements

This document is an English version of *El comercio internacional y la economía circular en América Latina y el Caribe*, published by the Economic Commission for Latin America and the Caribbean (ECLAC). The original document was prepared within the framework of the activities of the 2017-2019 Cooperation Agreement between ECLAC and the Government of the Republic of Korea. The contributions of Javier Meneses, research assistant of the International Trade and Integration Division of ECLAC, and the information shared by TriCiclos Chile, Werba S.A. and the Basel Convention Coordinating Centre for Latin America and the Caribbean, as well as the collaboration of the KAS ADELA program, are gratefully acknowledged.

Applications for authorization to reproduce this work in whole or in part should be sent to the Economic Commission for Latin America and the Caribbean (ECLAC), Publications and Documents Division, publicaciones.cepal@un.org. Member States and their governmental institutions may reproduce this work without prior authorization but are requested to mention the source and to inform ECLAC of such reproduction.

Copyright © United Nations, 2021.

The designations employed, descriptions and classifications of countries, and the presentation of the material in this report do not imply the expression of any opinion whatsoever on the part of the Secretariat of the United Nations Industrial Development Organization (UNIDO) or of the Economic Commission for Latin America and the Caribbean (ECLAC) concerning the legal status of any country, territory, city or area or of its authorities, or concerning the delimitation of its frontiers or boundaries, or its economic system or degree of development. The views expressed in this paper do not necessarily reflect the views of the Secretariat of the UNIDO or of ECLAC. The responsibility for opinions expressed rests solely with the authors, and publication does not constitute an endorsement by UNIDO or ECLAC. Although great care has been taken to maintain the accuracy of information herein, neither UNIDO nor its member States assume any responsibility for consequences which may arise from the use of the material. Terms such as “developed”, “industrialized” and “developing” are intended for statistical convenience and do not necessarily express a judgment. Any indication of, or reference to, a country, institution or other legal entity does not constitute an endorsement. Information contained herein may be freely quoted or reprinted but acknowledgement is requested. This report has been produced without formal United Nations editing

Glossary

ASTM International	American Society for Testing and Materials
B2B	Business-to-Business
B2C	Business-to-Consumer
BACI	International Trade Database at the Product Level
BCCC	Basel Convention Coordinating Centre
BFR	Brominated flame retardants
C2C	Consumer-to-Consumer
CEN	European Committee for Standardization
CEPII	Centre for Prospective Studies and International Information
CFC	Chlorofluorocarbon
CO ₂	Carbon dioxide
COMTRADE	International Trade Statistics Database
COPANT	Pan-American Standards Commission
CTCN	Climate Technology Centre & Network
ECLAC	Economic Commission for Latin America and the Caribbean
EITI	Extractive Industries Transparency Initiative
EPR	Extended Producer Responsibility
EU	European Union
G20	Group of Twenty
G7	Group of Seven
GDP	Gross domestic product
GHG	Greenhouse gas
GVC	Global value chain

HCFC	Hydrochlorofluorocarbons
HS	Harmonized Commodity Description and Coding System
ICT	Information and communications technology
ISO	International Organization for Standardization
LAC	Latin America and the Caribbean
MERCOSUR	Southern Common Market
OECD	Organisation for Economic Co-Operation and Development
PACE	Platform for Accelerating the Circular Economy
PAGE	Partnership for Action on Green Economy
PET	Polyethylene terephthalate
PIC	Prior Informed Consent
POP	Persistent Organic Pollutant
R&D	Research and development
SDG	Sustainable Development Goal
TTIP	Transatlantic Trade and Investment Partnership
UNEP	United Nations Environment Programme
UNIDO	United Nation's Industrial Development Organization
WEEE	Waste Electrical and Electronic Equipment
WTO	World Trade Organization

Table of Contents

Introduction	1
1. Interface between international trade and the circular economy in LAC	3
1.1 The circular economy promotes a more sustainable post-pandemic recovery	3
1.2 International trade and the circular economy in LAC: incentives and disincentives	6
1.3 International trade is absent from LAC’s national circular economy agendas.....	18
2 International trade can promote the transition from waste to resource.....	21
2.1 Limitations in quantifying the circular economy in international trade	21
2.2 Global waste trade is concentrated in minerals and metals	22
2.3 The commercial circuits of waste are concentrated in Europe and Asia.....	27
2.4 The LAC region has minimal participation in global waste trade.....	29
2.5 Intra-regional trade in waste is low and diversified.....	32
3 Towards circular industries	34
3.1 The mineral and metal recycling industry	34
3.2 Environmental and economic incentives for the circularization of aluminium.....	36
3.3 Environmental and economic incentives for the circularization of copper	39
4 Necessary coordination of trade policy and circular economy agendas	42
4.1 The WTO indirectly addresses the circular economy	42
4.2 The EU’s circular economy strategy has an impact on international trade	44
4.3 Through its trade agreements and other instruments.....	45
4.4 Through international cooperation	46
5 Conclusions and recommendations	50
5.1 Conclusions	50
5.2 Recommendations	52
5.3 Policy recommendations	54
Annexes.....	65

List of Figures

Figure 1	Market alternatives associated with the links of a production chain under a circular economy logic.....	7
Figure 2	Global exports of waste in value by mega-industries, 2002–2018.....	22
Figure 3	Global exports of waste in volume by mega-industries, 2002–2018	23
Figure 4	Global exports of waste (in value) and unit value of steel waste and scrap, 2002–2018	24
Figure 5	Selected regions: Participation in global waste exports in value, 2002–2003, 2011–2012 & 2017–2018	27
Figure 6	Selected regions: Participation in global imports of waste in value, 2002–2003, 2011–2012 & 2017–2018	28
Figure 7	Latin America and the Caribbean: Exports and imports of waste, 2002–2018.....	30
Figure 8	Latin America and the Caribbean: Waste exports to main destinations by mega-industries, 2018.....	31
Figure 9	Latin America and the Caribbean: Waste imports from main origins by mega-industries, 2018	31
Figure 10	Latin America and the Caribbean: Intraregional exports by mega-industries, 2002–2018	32
Figure 11	Aluminium production chain	36
Figure 12	Unit values of world exports of alumina and aluminium waste and scrap, 2002–2018 ..	38
Figure 13	Copper production chain	40
Figure 14	Unit values of global exports of copper waste and scrap and copper ores and concentrates, 2002–2018	41
Figure 15	Selected regions: Number of recycling-related measures notified to the WTO, 2009–2018	43

List of Tables

Table 1	Latin America and the Caribbean (selected countries): Summary of circular economy agendas	18
---------	---	----

Abstract

The circular economy has been introduced into the public policy agenda and private sector activity in several countries in Latin America and the Caribbean, as has been the case in other regions of the world. The link between the circular economy and international trade, however, has yet to be explored. In this context, this document analyses the relationship between both factors in the region through a literature review, the description of trade flows of waste, and an analysis of how the circular economy is incorporated into trade policy. It emphasizes the need for greater mainstreaming of international trade in national strategies for the circular economy, and the importance of international cooperation and public-private partnerships for the creation of scale and the transfer of knowledge and technology, as well as the need for the harmonization of definitions and standards.

Introduction

The circular economy has gained adherents in public policy agendas and private sector activity across all continents. By proposing the decoupling of economic growth from the exploitation of finite natural resources and energy use, the circular economy is proposed as a key tool to achieve several Sustainable Development Goals (SDGs) of the 2030 Agenda. Circular policies are part of the public agendas of the European Union (EU) and China; and have been adopted in recent years in several Latin American and Caribbean (LAC) countries. This trend is also recently being considered in the multilateral agenda, and incorporated into a growing number of business models.

There is an intrinsic link between the circular economy and international trade that has been scarcely explored. As of 1 January 2018, China's ban on imports of non-industrial plastic waste has had environmental impacts in the countries of origin, and it has become clear that the circular economy cannot only be addressed at the domestic level. Similar conclusions are reached when analysing the potential international impacts of EU circular policies. A global perspective must be adopted when evaluating the circular economy in order to promote it and facilitate its scaling up.

Governments and society are calling for the recovery from the recession caused by the Covid-19 pandemic to be more environmentally sustainable and more equitable. The recovery from the crisis should also contribute to limiting the acceleration of climate change and improve people's health and prosperity. The Economic Commission for Latin America and the Caribbean (ECLAC) projects an average drop in gross domestic product (GDP) of 9 per cent for LAC in 2020, and a contraction in exports of 23 per cent (ECLAC, 2020b). ECLAC's call for LAC countries to move towards a more sustainable, low-carbon development model has become even more relevant in the context of Covid-19¹. Acceleration towards a circular economy can provide an enabling path for this new development model.

This paper aims to analyse the link between the circular economy and international trade in the regional context. It seeks to answer the following questions: What characterizes the relationship between international trade and the circular economy? Have public agendas that promote the transition to circularity included foreign trade as a driving force? How is LAC's trade in waste organized? Are there industries with greater potential for circularity? What do trade policy trends indicate about the link between trade and the circular economy? Finally, how can the region boost

¹ See ECLAC, Alicia Bárcena reaffirms the urgency of moving towards a more sustainable development model that will increase productivity and achieve equality in the region, 2020.

the contribution of international trade towards the transition to a circular economy at the global level?

The paper's objective is to answer the above questions through: i) a literature review, ii) an analysis of global and regional trade flows of waste, and sectors with potential for circularity, and iii) interviews with key figures of different initiatives in the region that address aspects of the circular economy and trade in waste.

This paper is structured as follows. The first section introduces various links between the circular economy and international trade and finds that these could be reinforced by the impacts of the Covid-19 pandemic. In the second section, the most relevant circular economy-related waste streams in the region are described and analysed within the global waste trade context. The third section characterizes the configuration of the aluminium and copper industries in LAC to identify opportunities and initial challenges in the implementation of circularity in specific industries. The fourth section addresses the global trade policy trends in the transition to a circular economy and the challenges they pose for LAC.

1. Interface between international trade and the circular economy in LAC

1.1 The circular economy promotes a more sustainable post-pandemic recovery

The linear production and consumption model, along with the increase in the world's population and its level of material well-being, is one of the main causes of the climate crisis, which in turn has exacerbated the economic and social impact of the Covid-19 pandemic. In fact, the share of material production in total greenhouse gas (GHG) emissions grew from 15 per cent in 1995 to 23 per cent in 2015 (International Resource Panel, 2020)

Between 2020 and 2060, the world's population is expected to increase from 7 billion to 9 billion; per capita GDP is projected to rise as well, resulting in a doubling of global material consumption (OECD, 2019). A transformation towards more circular production chains could offset this development. Implementing circularity strategies in just five industries (steel, cement, plastic, food and aluminium) could reduce GHG material emissions by 40 per cent or by 3.7 billion tonnes by 2050 (Ellen MacArthur Foundation, 2019a).

The circular economy model “aims to keep products, components, and materials at their highest utility and value at all times” in contrast to the traditional linear model based on “take-make-waste” (Ellen MacArthur Foundation, 2015). It applies cradle-to-cradle design and eco-effectiveness. Accordingly, industrial systems and products are designed to maintain the quality and productivity of materials through successive life cycles (Braungart & Bollinger, 2007). The circular economy fosters the incorporation of value in all links of the productive chain to extend the lifespan of products, components and materials. The transition to circularity is thus based on three principles: i) eliminate waste and pollution; ii) keep products and materials in use; iii) regenerate natural systems. Box 1 explains several concepts used in this document (Ellen MacArthur Foundation, 2015).

The circular economy proposes the decoupling of economic growth from the exploitation of finite natural resources and energy use by increasing resource efficiency. It therefore entails significant environmental benefits and is key to achieving sustainable consumption and production systems (Schröder, Anggraeni, & Weber, 2018).

Box 1 Concepts of the circular economy and international trade

Several concepts employed in circular economy literature are defined below.

Waste: according to European legislation, waste refers to “any substance or object which the holder discards or intends or is required to discard” (European Union, 2008). The Ellen MacArthur Foundation adds that “all waste can be feedstock for another production process” (Ellen MacArthur Foundation, 2019b).

By-product: “an inevitable result of certain types of material processing [...] all by-products can be feedstock for another production process” (Ellen MacArthur Foundation, 2019b). In some cases, trade data do not allow for a clear distinction between by-products and co-products of manufacturing processes from those considered waste/scrap. In this study, “waste” and “scrap” are used interchangeably.

The different ways of adding value to a given material result in the following goods/services:

Secondary raw material: when recycling is involved, which is defined as “any recovery operation by which waste materials are reprocessed into products, materials or substances whether for the original or other purposes.” (European Union, 2008). By contrast, virgin raw materials are directly derived from extractive processes.

Remanufactured or reconditioned good: when the lifespan of a product is extended through design. Remanufacturing consists of disassembling the product at the component level and rebuilding it—replacing obsolete components, if necessary—into ‘as new’ condition. Reconditioning consists of repairing a product to the greatest extent possible, usually without disassembling it or replacing components (Ellen MacArthur Foundation, 2019b).

Used or second-hand good: when a good is reused and repaired. Reuse is defined as “any operation by which products or components that are not waste are used again for the same purpose for which they were conceived” (European Union, 2008). The goods maintain their original form with few modifications.

Product-as-a-service or servitization: is a business model whereby the product/good does not belong to the end user, rather, the end user pays for the use or lease of a service provided by the manufacturer or a third party. This allows for easier renovation and reuse or remodelling of products in a closed circuit. Car-sharing platforms serve as an example of servitization (Ellen MacArthur Foundation, 2019b).

Source: Prepared by the authors based on European Union (19 November 2008). Directive 2008/98/EC. Retrieved from European Union [on-line] <https://eur-lex.europa.eu/eli/dir/2008/98/oj/spa>; Ellen MacArthur Foundation. (2019b). Resources: Apply: Circulytics-measuring circularity: Resources. Cowes: Ellen MacArthur Foundation. Retrieved from Ellen MacArthur Foundation [on-line] <https://www.ellenmacarthurfoundation.org/assets/downloads/Circulytics-definitions-list.pdf>.

While transition to a circular economy contributes to minimizing the extraction and consumption of natural resources, waste generation, energy usage and GHG emissions, it also presents multiple economic opportunities. The conservation of finite raw materials reduces disruptions in supply and ensures their long-term use by local economies. Circularity also saves costs and promotes the development of new business models (CEPS, 2016). It might even drive reindustrialization by strengthening several industries, such as secondary raw material production, repair,

reconditioning and remanufacturing, the service sector and the sharing economy (McCarthy, Dellink, & Bibas, 2018). The circular economy can offer an opportunity for economic diversification, value creation and capacity-building (Wellesley, Lehne, & Preston, 2019). By promoting business-to-business (B2B) exchanges and by building synergies, it improves the economic, social, and environmental performance of economies, opens new markets, and generates new jobs (UNIDO, 2017).

Therefore, promoting the circular economy is one way of fostering a sustainable post-pandemic economic recovery (Schröder et al., 2020). While the global economic slowdown has led to a drop in carbon dioxide (CO₂) emissions, the United Nations Environment Programme (UNEP) states that these are temporary consequences of the Covid-19 pandemic, and that a real positive impact requires a systemic transformation in production and consumption habits towards a cleaner environment². In LAC, the economic and social crisis unleashed by the pandemic has revealed the weaknesses of the extractive production model predominantly characterized by primary product exports (minerals and metals, agricultural products), with few incentives for the development of higher value-added or knowledge-intensive activities (ECLAC, 2020a).

As a strategy to emerge from the current crisis, ECLAC is promoting the Big Push for Sustainability based on a new development strategy, which includes changes in the production structure to achieve greater equality and sustainability³. Moving forward in the transition towards a circular economy in LAC, and promoting its ties with international trade to scale it up, can significantly contribute to this strategy as well as to the transformation needed to build an economy that preserves the planet's health. Likewise, circular economy practices that are interlinked with international trade can help achieve several SDGs (see Box 2).

² See UN News: Coronavirus Pandemic is an Opportunity to Build an Economy that Preserves the Health of the Planet, 2020.

³ See ECLAC, Press Release: ECLAC calls for a Big Push for Sustainability as a Strategy for Emerging from the Current Crisis, 2020.

Box 2 The potential contribution of the circular economy and international trade to the achievement of the SDGs

The transition to a circular economy contributes to the achievement of several objectives of the 2030 Agenda (Schröder, Anggraeni, & Weber, 2018). While the circular economy is intrinsically linked to SDG 12 (sustainable production and consumption), it facilitates progress on other environmental, economic and social SDGs that are also linked to international trade.

Given the dependence of some LAC economies on natural resource exports, and the macroeconomic vulnerabilities generated by commodity cycles, along with the inability to develop appropriate counter-cyclical macroeconomic policies (Ocampo, 2017), the circular economy represents an opportunity for intrasectoral diversification and domestic value addition. It thereby also contributes to SDG 8 (decent work and economic growth) and SDG 9 (industry, innovation, and infrastructure).

Additionally, since the circular economy is based on minimizing the extraction of natural resources—even encouraging their regeneration—reducing demand for raw materials exported by the region—and consequently their extraction—would contribute to SDG 15 (life on land) and SDG 13 (climate action).

Source: Prepared by the authors based on: Schröder, P., Anggraeni, K., & Weber, U. (2018). The relevance of circular economy practices to the Sustainable Development Goals. Yale University y Ocampo, J.A. (2017). Commodity-led development in Latin America. Alternative pathways to sustainable development: Lessons from Latin America. International Development Policy Series No. 9, 51-76.

1.2 International trade and the circular economy in LAC: incentives and disincentives

While most public circular economy agendas focus on the domestic market, an international approach is also necessary (Yamaguchi, 2018). It is important to study the links between international trade and the circular economy, analysing the characteristics of international trade flows of waste linked to global value chains (GVCs), the growing demand for sustainable products in developed markets and the importance of several national trade policy initiatives, such as the waste import ban implemented by China and the Green Deal promoted by the EU.

When thinking about the interface between circular economy and international trade, the tendency is to focus on trade in waste; however, the implementation of circular practices affects several links in the value chain of a product and can even transform a product into a service. Figure 1 illustrates the chain of production of a good or service and the market alternatives presented in each link under a circular economy logic, both internally (upper boxes) and on the international trade level (lower boxes). The upper boxes identify the different existing strategies for the application of the circular economy in a production chain (Yamaguchi, 2018).

Figure 1 Market alternatives associated with the links of a production chain under a circular economy logic

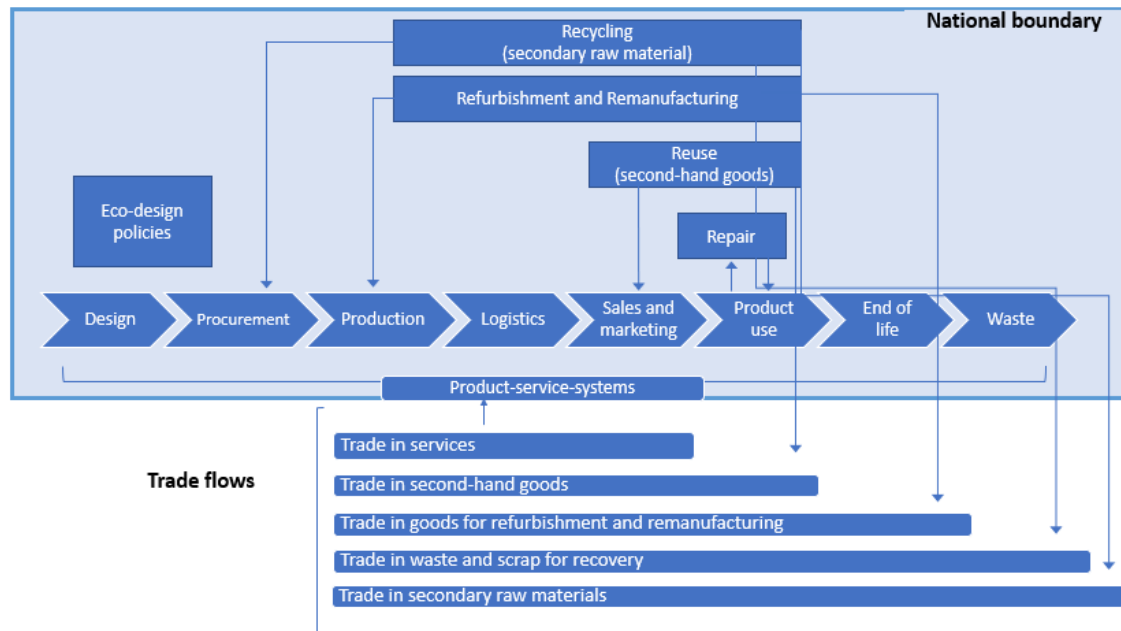

Source: Shunta Yamaguchi (2018), “International trade and the transition to a more resource efficient and circular economy: A concept paper”, *Trade and Environment Working Papers*, No. 3, Paris: OECD.

To clarify the multiple points of contact between the circular economy and international trade, the following section will first describe the five trade flows showcased in the lower boxes, based on the definitions in Box 1, and the opportunities and challenges they present. Secondly, the main incentives and disincentives between international trade and the circular economy will be identified. The analysis will delve into the regional context of LAC.

1.2.1 The five types of commercial flows under a circular economy logic

a) Trade in services

The transition towards a circular economy requires establishing a link between trade in goods and trade in services (UNEP, 2018). On one hand, it is expected that the services associated with waste management, recycling, reconditioning, remanufacturing, reuse and repair industries will grow globally. One example is the logistics service sector, which receives materials from different markets to reincorporate them into production processes and to provide them to clients of different value chains. The services of recovery, segmentation and stockpiling of materials must be adequate to ensure profitability and quality processing (Ellen MacArthur Foundation, 2015).

Moreover, the design of product-as-a-service (servitization) business models can also create new markets and generate an increase in the commercial flows of goods and services. Although servitization already exists in certain industries, particularly in B2B (e.g. agricultural machinery rental for crops), the circular economy proposes the development of this model in business-to-

consumer (B2C) and consumer-to-consumer (C2C) as well. These business models are often associated with information and communication technologies (ICTs) and require a certain level of software development and internet access. The sharing economy and platform economy models also exist. The former is based on exchanges at the community level, although it can also be implemented on a larger geographical scale (e.g. Grin Scooters or the Couchsurfing network). The latter is growing exponentially and allows for rapid scaling of the product-as-a-service model; it refers to examples such as Airbnb or Uber (CEPS, 2016). The digital tools used in these models facilitate traceability and data transparency.

There is also growing demand for consulting services related to the transition to circular models. Advisory services will be needed by companies through tools such as life cycle analysis and life cycle costs in the different production chains, as well as by governments to carry out diagnoses, build agendas and develop public-private instruments. While large multinational companies provide such services, there are also Latin American companies that specialize in national and international consultancy for the private sector and accompany the public sector in the transition to a circular economy.

Demonstrating that environmental costs and benefits must be accounted for and taken into consideration in the establishment of sustainable product-as-a-service models is part of the paradigm shift. It is important to bear in mind that companies are generally reluctant to change their business models. Contributing to the incorporation of circularity into production processes does not only mean thinking about an ecological design that facilitates reuse, repair and recycling, a sustainable solution for the end-of-life must also be considered (European Commission, 2020).

Trade policy instruments, such as standardization and certifications, among others, can have an important impact on the development of trade in services linked to circular economy practices (Yamaguchi, 2018). In addition, they allow for the classification of circular products or services, facilitating their traceability in international statistics.

b) Trade in used and second-hand goods

Improving resource efficiency and extending product life requires removing existing barriers related to trade in used and second-hand goods (OECD, 2016). This would imply responsibility of the importing countries for end-of-life treatment of these goods, which might entail challenges and additional costs. Moreover, some used goods, such as vehicles, may generate undesired impacts on import markets because they may be more polluting and inefficient than new goods.

Little information exists about the nature and magnitude of this trade flow, in part because of the difficulty of determining which goods can or cannot be reused. Several companies import used goods for reconditioning and remanufacturing, which are generally classified as waste in trade statistics (Yamaguchi, 2018). Some tariff codes exist that identify, for example, used clothing or used and retreated tires. These products are generally imported by developing countries, while many developed economies prohibit their import.

c) Trade in refurbished or remanufactured goods

Remanufactured goods are usually commercialized in the domestic market and often face barriers to re-export because they do not meet international market standards or requirements (Yamaguchi, 2018). Caterpillar and Komatsu are examples of multinational companies that have remanufacturing centres specialized in reconditioning machinery and their parts and pieces (Kojima, 2017). There are no statistics on the trade flow of these goods since they are not identified in the Harmonized System of Trade in Goods (HS).

d) Trade in waste and scrap for recovery

Trade in waste is considered to have a circular logic only if the waste can in fact be recovered and valorized in the receiving country under adequate environmental and social controls. Transboundary trade in waste occurs when countries choose to export their waste or do so because they cannot manage it internally. There is permanent concern in trade and environmental negotiations about the possible negative environmental and social impacts associated with this trade flow, especially in developing countries where regulations are laxer than in developed countries. One example of this is the negative impact the Chinese ban on plastic waste imports has had on new importing countries in Southeast Asia, which do not have the necessary infrastructure and illegally manage their waste imports (Kettunen, Gionfra, & Monteville, 2019). In LAC, an important part of waste sorting and recycling remains in the hands of informal sectors of the economy (Schröder et al., 2020).

While awareness about the importance and opportunity of considering waste as a resource is growing, there are still several challenges to making it viable. Importing waste for recovery can generate employment in the recycling and repair industries and promote domestic production of secondary raw materials (or secondary production) (Kettunen, Gionfra, & Monteville, 2019). The main challenge is that waste recovery must be profitable. Another requirement is the existence of adequate technological, human and institutional capacities in the receiving country. Other challenges facing this trade flow are the prevention of illegal trade and the adoption of common waste definitions and classifications between exporters and importers.

Transboundary trade in hazardous waste is regulated by the Basel Convention. The Convention constitutes a control mechanism for such waste to be treated close to its generation source to avoid environmental damage. However, it is estimated that there is a structural incentive to illegal trade in hazardous waste, particularly in the case of waste electrical and electronic equipment (WEEE) (Yamaguchi, 2018). Illegal trade in WEEE occurs on a large scale, encouraged by increasing trade flows and gaps in waste regulations, and is considered to interfere with the sustainable development of importing countries (Kettunen, Gionfra, & Monteville, 2019).

Although there are tariff codes in the HS that allow for identification of waste and scrap flows, there are still important gaps regarding their traceability. On one hand, it is impossible to distinguish how waste will be treated in the importing country, that is, to analyse the process and quality of waste valorization. On the other hand, it is also not possible to distinguish between waste that has already been converted into secondary raw material in the country of origin, waste that has not been treated prior to export and that can be valorized at destination, and waste that is commercialized but cannot valorize waste. Existing definitions (see Box 1) do not clearly distinguish between waste and secondary raw material. National jurisdictions also use different definitions and classifications. The HS tariff codes do not identify secondary raw materials as such. Among what is identified as waste, not everything can actually be recovered. In other words, part of the trade in waste is not captured by the current trade classification system. Additionally, most of the waste generated globally remains within national boundaries; it is therefore not included in the statistics analysed for this publication.

e) Trade in secondary raw materials

This particular trade flow is key to promoting the decoupling of economic growth and natural resource use. It is based on the substitution of virgin raw materials with secondary raw materials. This could have significant implications for LAC's international trade, which will be discussed later.

At the conceptual level, the trade flow in secondary raw materials differs from the previous one in that the good has already been valorized in the exporting country and the secondary raw material is traded whereas in trade in waste, the good is valorized in the importing country. The circular economy aims at upcycling, whereby waste is transformed into secondary raw material with an even higher value than before (OECD, 2018a). One example of this is the production of clothing made from plastic waste. This poses the challenge of avoiding downcycling, i.e. when the recycled material is of lower quality than the virgin material, since this limits its reuse for certain applications.

The previous point raises some of the challenges in quantifying this trade flow. In addition to the lack of agreed definitions about the difference between “waste” and “secondary raw materials”, the HS classification does not identify the latter. If such flows could be mapped out in more detail, we could potentially discern to what extent some facilitate upcycling and others downcycling. Another challenge posed by countries that import secondary raw materials is the need to be able to control the quality of these goods (Yamaguchi, 2018).

1.2.2 Incentives and disincentives exist between international trade and the circular economy in LAC

a) The circular economy in LAC’s trading partners reduces demand for virgin raw materials

The circular economy promotes the substitution of virgin raw materials with secondary raw materials, which could lead to a reduction in trade flows of minerals from the extractive industry, one of LAC’s main exports. Advances in secondary material production in China, the United States and the EU are driving a downward trend in demand for virgin raw materials. This may imply a decrease in resource extraction in the countries of origin (Kettunen, Gionfra, & Monteville, 2019). For countries importing such goods, this trend also implies the mitigation of supply risks associated with future geopolitical challenges of access to resources (McCarthy & Börkey, 2018).

The impact this could have on the economies of and employment in LAC countries that specialize in these types of goods must be considered. For example, if China were to develop a circular economy strategy for steel, this would affect Brazil as an exporter of iron ore (Nechifor et al., 2020). In a recent paper, Dellink (2020) analyses the impact of a package of measures proposed by the OECD to boost transition to a circular economy in international trade, and argues that the implementation of circular production in several countries will result in a cheaper market for secondary raw materials compared to virgin raw materials⁴. By 2040, he estimates a decrease in international trade by 35 per cent to 50 per cent for non-ferrous metals, 15 per cent for primary iron and steel, and 10 per cent for non-metallic minerals.

However, the path to a more circular low-carbon economy is also associated with increased digitalization and a transition to clean energy. These trends, coupled with a rise in the world’s population and wealth, may signify an increment in global demand for raw materials in both developed and developing countries (Kettunen, Gionfra, & Monteville, 2019). The E-waste World Monitor 2020 presents a substitution analysis of recovered and virgin aluminium, copper and iron. It concludes that while the use of virgin materials would be reduced in the hypothetical

⁴ The report bases its conclusions on the results derived from the application of an economic model (ENV-Linkages model) developed by the OECD.

case that 100 per cent of WEEE materials generated were recycled, the gap between the amounts recovered and the level of demand would remain wide (Forti et al., 2020). There is evidence that the quantity of materials that must be mobilized to supply domestic consumption has increased (Wiedmann et al., 2015).

These trends can be interpreted as an opportunity for LAC. Promoting greater circularity in the minerals and metals industries does not mean the disappearance of extractive industries, but would instead complement them. On one hand, countries in the region that are dependent on mineral resource imports, such as Mexico, could increase their secondary production and reduce their imports of virgin raw materials, as promoted by developed countries in their circular economy policies. On the other hand, primary producers, using their expertise and capacities in the sector, could integrate secondary production in their business models, as well as add value to the virgin raw materials they produce. The challenge for mining companies to remain competitive in the circular economy will be to increase partnerships with downstream users (Thimmiah, 2014) and to incorporate environmental and social responsibilities in their business models.

b) The territorialization of value chains shortens the distances of trade in waste and secondary raw materials

The transition to a circular economy in various markets will have an impact on the volumes and prices of waste and secondary raw material flows. In line with the previous point, the circular economy would shorten the geographical distances of material flows and develop local, increasingly resource-efficient value chains. As each country reduces the waste it generates and engages in the valorization of waste at the local or regional level, volumes as well as distances in international trade in waste can be reduced.

It is relevant to analyse how the quality of waste and secondary raw materials that are commercialized evolves as the transition to a circular economy progresses. In part, waste exports from each country depend on domestic regulations. Stricter regulations, as in the case of the EU, generate greater local demand for such goods, since the necessary technology to valorize the materials is available, and, for example, can therefore be processed into secondary raw materials. Consequently, a smaller proportion of solid waste ends up in landfills or is exported, while a larger share is processed locally. However, in many cases, clean and sorted quality waste is processed internally, while the rest is sent to other countries for recycling (OECD, 2020d).

c) International trade encourages economies of scale

Waste valorization must be profitable. If it is not profitable domestically, the way to add value to waste is to export it. This occurs when the external market offers favourable rates, which is not always the case. International trade promotes achievement of the necessary scale of waste domestically to develop a profitable recovery business.

Some materials, such as aluminium and copper, are perfectly circular, that is, they can be infinitely recycled without losing their quality. In addition to the environmental benefits, their circularization may come at a lower cost than their extraction and, consequently, result in savings. The profitability of secondary production of these materials depends on economies of scale and on the availability of technology for adequate treatment. One way to achieve scale—and therefore profitability—is to encourage regional treatment of the materials. This would represent progress towards circularity; however, there are several barriers that need to be overcome.

The CEO of TriCiclos, a Chilean company with subsidiaries in Brazil and Colombia⁵, confirms that scale and technology are two key factors in making the recycling of materials possible within a given territory. The types of materials that TriCiclos classifies for further treatment depend on each market, and must be adapted to different local realities. The company also provides advisory services to multinational companies in LAC for the reutilization of materials they place on the market. These companies do not standardize their practices in all countries they sell their products to due to the differences in each⁶.

d) Technology and capacity development to enable the circular economy

Another challenge LAC faces in scaling up circular processes and products is the development of local technological, human and institutional capacities. The improvement of the available technology, on the one hand, allows achievement of the valorization process itself in an environmentally and socially appropriate manner in accordance with the volume and technical characteristics of the materials to be treated. On the other hand, it facilitates the traceability of materials and logistics to ensure the efficiency of such valorization. At the social level, the technological transformation brings with it the need for skilled labour and new jobs, thus promoting labour reconversion.

⁵ TriCiclos bases its business model on the promotion of the circular economy through the installation of “clean points” to provide the correct final disposal for various waste generators and to ensure proper management of waste, as well as their transformation into secondary raw materials, where possible.

⁶ Interview with Veronica de la Cerda, TriCiclos CEO, 30 July 2020.

Investment in technology for the valorization of certain materials is facilitated by the existence of a sufficient level of scale to make it profitable. International trade therefore also generates opportunities in this regard. There are important investment needs in LAC, as well as for international and even south-south cooperation, for technological improvements and knowledge transfer. Technological innovation for the transition to a circular economy is still in the development phase at the global level; hence, research and development (R&D) is essential for identifying the most appropriate solutions for the realities of the region. The generation of circular value chains among several LAC countries, considering the level of knowledge and economic structure of each, could facilitate the achievement of a satisfactory technological level and sufficient economies of scale, to add value to waste in the region with the potential of being valorized rather than exporting it to developed countries.

e) The circular economy generates comparative advantages in certain export sectors and creates new markets

The bioeconomy is based on the consumption and production of goods and services derived from the direct use and transformation of biological resources, including biomass waste generated in the transformation, production and consumption processes (Rodriguez, Mondalini, & Hitschfeld, 2017). As an exporter of agricultural products and a source of biodiversity, genetic resources and productive landscapes, LAC has the resources and knowledge to specialize in the development of the bioeconomy and low-carbon industrial food systems, in line with the regeneration principle of the circular economy. In the case of large agricultural producers, adding value to the sector's waste is a way of making better use of the available resources without affecting, for example, food security. Over the last two decades, several countries in the region (such as Argentina, Colombia, Costa Rica, Ecuador and Uruguay) have developed bioeconomic strategies that promote both the food industry and the development of bioproducts and bioenergy. Since the bioeconomy in itself is not necessarily sustainable, it is important to ensure that national strategies are aligned with the principles of the circular economy. This is certainly a niche for access to new markets (Schröder et al., 2020).

Offering export products with circular characteristics, a low environmental and carbon footprint (life extension, maintenance, recyclability), and with a socially fair background, allows overcoming certain entry barriers to several increasingly demanding markets, such as the EU. In addition, the products that manage to position themselves in European niches can obtain better prices. Initiatives along these lines already exist in the region, for example, the “carbon neutral meat” production initiatives in Southern Cone countries or the “low emission coffee” initiatives in Central America.

On the other hand, the development of digital services that promote the circular economy is a potential niche for LAC. The region stands out for its digital infrastructure coverage (only 10 per cent of the population lives outside 4G or 3G networks) and its extensive software development services. According to the Digital Evolution Index 2018, (in decreasing order) Bolivia (Plurinational State of), Ecuador, Uruguay and Mexico are heralded for their rapid evolution towards digitally-based innovation⁷. The service sector registers a high participation rate in the regional economy but is generally characterized by low productivity (although the services facilitated by ICTs –which represent a smaller share–make for a much more dynamic performance), slowing down the region’s overall growth (Aboal et al., 2015). Developing servitization models could be an opportunity to diversify LAC exports.

f) The Harmonized System limits the traceability and scalability of the circular economy

The existing classification in the HS does not differentiate between the various types of goods in the circular economy. Therefore, the nature and magnitude of the valorization possibilities of the commercialized materials cannot be determined. It is important to further delve into the analysis of the HS to identify the necessary tariff code updates and revisions. Distinguishing goods that are inputs for secondary raw materials would facilitate the elimination of trade restrictions, removing the negative connotation associated with “waste”.

The currently available data underestimate the trade of products associated with the circular economy. The trade flow analysis in this document only considers certain types of waste, and excludes other materials since they cannot be identified in the tariff code.

Likewise, identifying processes and services that promote circularity is necessary. Thereby, a complete analysis of the trade flows in the transition towards a new paradigm could be performed, as well as a clear identification how they can be promoted to scale up the circular economy. To date, there are no international classifications available that allow such distinctions to be made.

g) Some trade policies still deter transition to a circular economy

Another important challenge in moving towards a global circular economy is the advancement of trade policy dialogue around the objectives of the circular economy (OECD, 2016) and the lifting of trade barriers that deter transition.

On one hand, some regulations and standards associated with the transition to a circular economy impact GVCs, for example, Extended Producer Responsibility (ERP) schemes, which assign responsibility for the product and its packaging at the end-of-life stage to the producer or importer.

⁷ For more information, see [on-line] <https://sites.tufts.edu/digitalplanet/tag/digital-evolution-index/>.

While these regulations provide some environmental and social security to national authorities, they also increase costs for producers and importers. Also, in case waste is exported for recovery, there is no guarantee that it will be adequately managed in the receiving country (Kettunen, Gionfra, & Monteville, 2019).

On the other hand, different domestic trade policy initiatives condition the transition to a global circular economy. One example is import bans on used goods and waste in general. With the aim of protecting the environment, the entry of certain materials that could be reused, remanufactured or converted into secondary raw material is prohibited or discouraged. However, as already mentioned, it is difficult to differentiate between such goods and, therefore, to determine when usage and recovery are possible in terms of the circular economy and when they are not. The Chinese ban on the import of plastic waste has had a significant effect on the global recycling industry. For its part, the EU is analysing how its circular economy strategy is shaping its global relations and the impact this could have on international trade.

One area that needs to be further developed is the harmonization of criteria, definitions and trade regulations between countries, for example, regarding the treatment of hazardous waste. Standardizing WEEE criteria within the framework of the Basel Convention would facilitate the traceability and treatment of metals these wastes are composed of and enhance their recyclability. Also, the absence of unified criteria and regulations on the treatment of plastic gives large multinational companies leeway to make promises to consumers and policy makers that ultimately do not materialize (Changing Markets Foundation, 2020).

Box 3 summarizes some incentives (disincentives) that strengthen (weaken) the relationship between the circular economy and international trade.

Box 3 Incentives and disincentives between the circular economy and international trade

Incentives between the circular economy and international trade

- International trade fosters economies of scale, which are key to making the circular economy profitable and scalable. Economies of scale also enable investment and technological development.
- Vice versa, for a product to be valorized, qualified technological and human capacities are needed, as well as the corresponding funding. One incentive for such investment is to stimulate an increase in trade.
- The implementation of the circular economy in LAC's productive export sectors can generate comparative advantages to access markets that are demanding in terms of environmental footprints, carbon footprints and social justice. It can also encourage local value addition in existing industries.
- The circular economy creates new markets and innovative business models based on digitalization. LAC can be both a consumer and exporter; one opportunity is the development of trade in services that promote circularity.

Disincentives between the circular economy and international trade

- The substitution of virgin raw materials with secondary raw materials in the economies of LAC's main trading partners, and the promotion of the territorialization of production chains at the global level, promote a decrease in the volume and distances of trade flows of virgin raw materials, secondary raw materials and waste.
- The Harmonized System limits the representation and traceability of the transition to a circular economy due to the absence of a detailed depiction of the different goods and services under a circular economy logic.
- There are multiple trade barriers to the circular economy, in particular national regulations and standards, which hamper the commercialization of materials for recovery, and have yet to be overcome to scale up the circular economy.

Source: Prepared by the authors based on: Kettunen, M., Gionfra, S., & Monteville, M. (2019). EU circular economy and trade: Improving policy coherence for sustainable development. Brussels/London: IEEP; McCarthy, A., & Börkey, P. (2018). Mapping support for primary and secondary metal production. Paris: OECD Environment Working Papers, No. 135; Schröder, P., MacEwen, M., Albaladejo, M., Alonso Ribas, P., & Tilkanen, J. (2020). The circular economy in Latin America and the Caribbean. Opportunities for building resilience. London: Chatham House; Yamaguchi, S. (2018). International trade and the transition to a more resource efficient and circular economy: A concept paper. Paris: OECD.

1.3 International trade is absent from LAC’s national circular economy agendas

In 2019, the Intersessional Meeting of the Forum of Ministers of Environment of LAC formed a Regional Coalition on Circular Economy. This coalition seeks to develop a common regional vision and strategy for the circular economy and exchange best practices to scale up its impact (UNEP, 2019). The incorporation of the circular economy in the region’s national agendas is on the rise, although progress has been uneven. Some countries have developed, or are in the process of developing, national strategies, plans or initiatives that promote the transition to a circular economy.

Table 1 identifies the countries in LAC that have developed or are developing a public policy strategy specifically for the circular economy. The economic sectors these plans are built on depend on the countries’ national priorities and are presented for those countries where the strategy has been formally approved.

Table 1 Latin America and the Caribbean (selected countries): Summary of circular economy agendas

Country	Strategy	Sectors
Colombia	National Strategy for the Circular Economy (approved in 2019)	<ul style="list-style-type: none"> • Materials from Waste Electrical and Electronic Equipment (WEEE) and hazardous waste • Materials from special tire waste • Material flows of containers and packaging • Biomass flows • Energy sources and flows • Water flows • Construction materials flows
Ecuador	Circular Economy Pact (approved in 2019) Phase I of the White Paper on the Circular Economy (under preparation, deadline October 2020), Towards a Circular Economy Strategy (under preparation, deadline December 2020)	Sectors for initial progress: <ul style="list-style-type: none"> • Manufacturing (except oil refining) • Agriculture • Commerce • Construction • Oil and mining
Uruguay	Circular Economy Action Plan (approved in 2019)	<ul style="list-style-type: none"> • Industry (dairy and meat chain) • Education (inclusion of circular economy topics in all education levels) • Public procurement (technical guidelines for prioritizing circular procurement) • On-demand electrical vehicles in the public sector • Technological Centre for Circular Bioeconomy (dairy, meat and forestry chain)

Country	Strategy	Sectors
Peru	Circular Economy Roadmap for Industry, under preparation (beginning 2020)	<ul style="list-style-type: none"> Material valorization
Chile	Circular Economy Roadmap, under preparation (beginning 2018)	
Costa Rica	Several strategic actions of the National Policy for Sustainable Production and Consumption 2018-2030 (beginning 2018) address aspects of the circular economy	
Argentina	The ARS (Association for Solid Waste Studies) constitutes the National Circular Economy Coalition and is drafting the National Strategy for the Circular Economy (beginning 2019)	
Brazil, Cuba, El Salvador, Mexico, Paraguay, and Dominican Republic	Diagnostic under preparation through regional technical assistance (beginning 2019)	
Panama	Initiating the creation of a Circular Economy Center (beginning 2019)	

Source: Prepared by the authors, based on: Colombia: see Government of Colombia, *Estrategia Nacional de Economía Circular: Cierre de ciclos materiales, innovación tecnológica, colaboración y nuevos modelos de negocio* [National Strategy for a Circular Economy: Closing of material cycles, technological innovation, collaboration and new business models], 2019. Ecuador: see UNACEM, *Resumen del informe final de la consultoría para la fase I del libro blanco de economía circular* [Summary of the Final Report of the Consultancy for Phase I of the White Paper on the Circular Economy], 2020. Uruguay: see Transforma Uruguay, *Plan de Acción en Economía Circular* [Circular Economy Action Plan], 2019. Peru: see Government of Peru, *Decreto Supremo N° 003-2020-Produce* [Supreme Decree N° 003-2020-Produce], 2020. Chile: see Jorge Molina Almar, *Medio Ambiente convoca a 25 actores clave para desarrollar la hoja de ruta que impulsará la adopción de la economía circular en Chile* [Environment convenes 25 key actors to develop the roadmap that will drive the adoption of the circular economy in Chile], 2020. Costa Rica: see Government of the Republic of Costa Rica, *Política Nacional de Producción y Consumo Sostenibles 2018 – 2030* [National Policy on Sustainable Production and Consumption 2018-2030], 2018. Argentina: see Asociación para el estudio de Residuos Sólidos, *Estrategia Nacional de Economía Circular [National Circular Economy Strategy]*, 2019. Brazil, Cuba, El Salvador, Mexico, Paraguay, Dominican Republic: see CTCN, *Technical Assistance*, n.d. Panama: see Ministry of Environment, *Acuerdo para la creación del Centro de Economía Circular* [Agreement for the Creation of a Circular Economy Center], 2019.

Note: Chile, Ecuador, and Uruguay are also in the process of preparing a diagnostic study through regional technical assistance provided by the CTCN, but the table prioritizes initiatives presented by national governments. See CTCN, *Technical Assistance*, n.d.

The promotion of circularity in the prioritized sectors does not reveal a link with the country's export profile. However, the selected sectors are closely interlinked with the main drivers of these economies, and are often directly or indirectly related to the products commercialized by the country. No national planning documents have been found that analyse the potential for internationalization of the circular sectors or, conversely, for the incorporation of circular economy strategies in the goods and services marketed by the country. Therefore, it can be said that there are no opportunities or challenges in this regard. Synergies would need to be identified and made visible.

LAC countries have also introduced, or are introducing, other policy measures linked to the circular economy, which must be considered when analysing specific circularity strategies and their link with international trade to avoid contradictions. Particularly noteworthy are the EPR schemes adopted by eight countries in the region (Brazil, Chile, Colombia, Costa Rica, Honduras, Mexico, Peru and Uruguay) to varying degrees and for different product categories, including WEEE, batteries and tires (Schröder et al., 2020).

In addition, planning processes and public policy strategies are identified which the circular economy and international trade agenda should be synergized. In Mexico, a proposal of the General Law of Circular Economy, submitted in November 2019, is being debated in Parliament (Senate of Mexico, 2019). In the case of Costa Rica, the 2018–2050 Decarbonization Plan was presented in 2018 (Government of the Republic of Costa Rica, 2018). In Colombia, the environmental management of packaging waste was regulated by encouraging innovation and eco-design (Ministry of Environment and Sustainable Development, 2018). In 2010, Bolivia (Plurinational State of) approved the Law of the Rights of Mother Earth (Ministry of Development Planning, 2010). Some countries approved a General Law of Integral Waste Management, as is the case of Uruguay in 2019 and El Salvador in 2020 (Parliament of Uruguay, 2019); Parliament of El Salvador, 2020).

2 International trade can promote the transition from waste to resource

2.1 Limitations in quantifying the circular economy in international trade

Although multiple points of contact between the circular economy and international trade have been identified in the previous section, in practice, the trade flows associated with the circular economy are difficult to quantify and the limited statistics available underestimate their real magnitude. Of the five trade flows identified above, only trade in waste and scrap is codified in the HS, which allows part of them to be quantified. Some secondary raw materials are also not identified as such but rather as waste. Most used and second-hand goods, as well as reconditioned and remanufactured goods, do not have their own classifications. Therefore, it is not possible to distinguish between a new and a used product, or between a used or reconditioned product and waste.

Despite the limitations, trade in goods classified as waste is increasingly considered trade in resources. Between 2002 and 2018, global exports of waste grew at an annual average rate of 21 per cent in value and 8 per cent in volume, almost double the growth of total trade in goods over the same period (which increased by an annual average of 12 per cent in value and 4 per cent in volume). The large formal global recycling circuits are concentrated among developed countries in the regions of (in decreasing order): the EU, Asia, North America and China. The participation of LAC and Africa is minimal. The reason(s) for this must be identified, considering the incentives and disincentives that exist between the circular economy and international trade. The analysis of global and LAC trade flows of waste thus allows i) characterization of what today can be quantified in the trade flows associated with the circular economy for LAC, and ii) identification of trends that will help with the incorporation of international trade into national circular economy strategies.

There is no comprehensive and unique list for identifying waste streams that become resources, although efforts have been made to agree on certain criteria. For example, Yamaguchi (2018) proposes lists of products covered by the Basel Convention; the Decision of the Council on the Control of Transboundary Movements of Wastes Destined for Recovery Operations [OECD/LEGAL/0266] also contains a list.

This work is based on these two lists and their homologation to the HS Nomenclature 2002 Edition, as well as other subheadings corresponding to wastes from the agricultural sector and the food and beverages industries⁸ (see Annex 1). The products were grouped into the following mega-industries: mineral and metal waste (including their manufactures); wood, paper and

⁸ Relevant industries for the region in its production and export basket.

cardboard waste; agricultural and food waste (including beverages); chemical and plastic waste (including rubber); and textile and leather waste.

The analysis of international trade flows is based on two sources: the International Trade Database at the Product-Level (BACI) of the Centre for Prospective Studies and International Information (CEPII), and the International Trade Statistics Database (COMTRADE). The former builds on the latter but provides harmonized values of trade flows, such as volumes in tonnes.

2.2 Global waste trade is concentrated in minerals and metals

Over three-quarters of the value of global trade in waste was concentrated in minerals and metals in the 2002–2018 period (Figure 2). Ranked next were wood, paper and cardboard waste (with an average of 9 per cent); agricultural and food waste (7 per cent); chemical and plastic waste (5 per cent); and textile and leather waste (2 per cent).

Figure 2 Global exports of waste in value by mega-industries, 2002–2018

(in billions of USD)

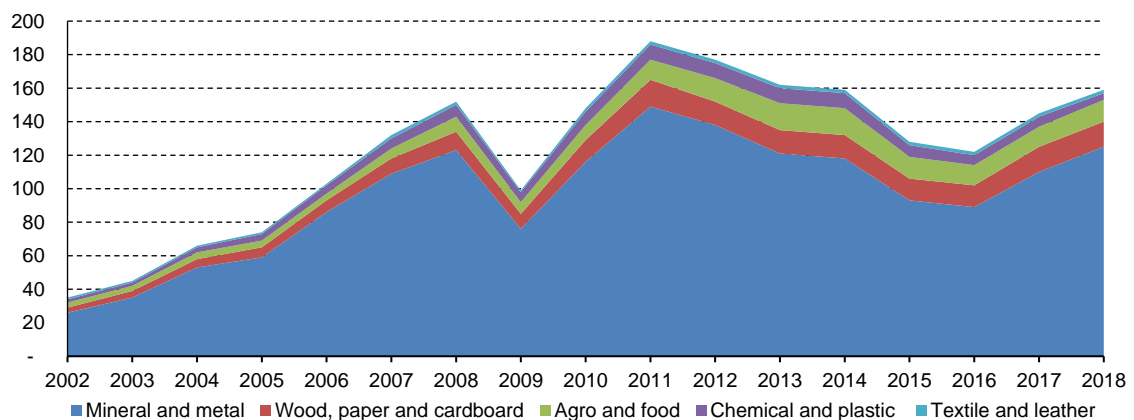

Source: Prepared by the authors, based on BACI/CEPII

Scrap metals also represent the majority (51 per cent) of exported volume (see Figure 3). Wood, cardboard and paper waste, on average, represent 23 per cent; agricultural and food waste: 15 per cent; chemical and plastic waste: 5 per cent; and textile and leather waste: 1 per cent.

Figure 3 Global exports of waste in volume by mega-industries, 2002–2018
(in millions of tonnes)

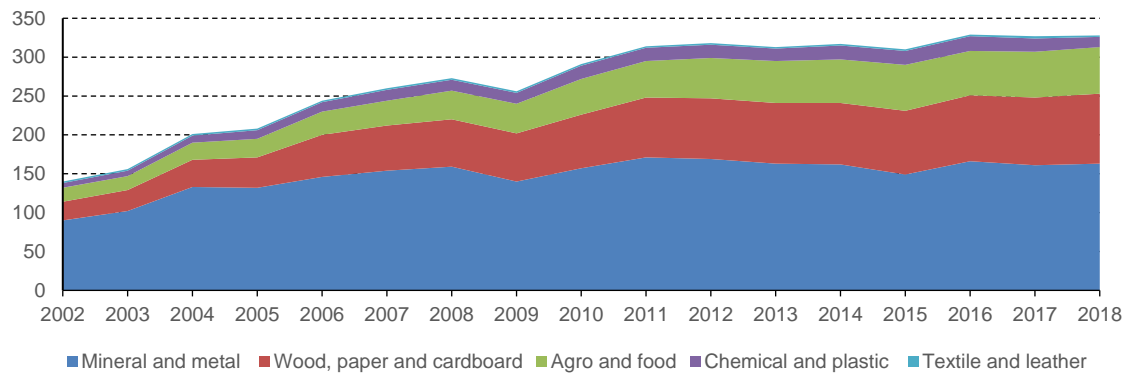

Source: Prepared by the authors, based on BACI/CEPII

2.2.1 Trade in mineral and metal waste

Steel, aluminium and copper waste and scrap are the leading exports. Steel scrap has the largest weight in global waste trade, reaching a volume of 105.4 million tonnes in 2018 (including intra-EU trade) (BIR, 2019). Aluminium scrap reached 8.93 million tonnes in 2018, while copper scrap totalled 5.03 million tonnes.

Given the great relevance of the volumes of steel waste in total waste exports, there is a direct relationship between the fluctuations in the value of global waste exports and the unit price of steel waste and scrap (see Figure 3). This price, in turn, depends on the costs associated with recycling and the prices of virgin raw materials. When the price of the latter rises, the scrap becomes more valuable as an alternative to producing secondary raw materials. In that sense, the development of international prices of virgin raw materials strongly affects the demand and trade of secondary raw materials (ISRI, 2020).

Figure 4 Global exports of waste (in value) and unit value of steel waste and scrap, 2002–2018
(in billions of current USD and in USD per kilogramme)



Source: Prepared by the authors, based on COMTRADE.

A significant part of the trade in steel waste takes place within the EU (29 million tonnes were exported and 21.4 million tonnes imported in 2018). In total, EU countries generated 112 million tonnes of steel waste in 2018. Of this total, about 11 million tonnes were exported to Turkey, the world's largest importer of steel waste and the destination for half of the EU's scrap exports. Turkey also receives a significant share of metal waste exports from the United States and Japan. It is followed, at a great distance, by the Republic of Korea and India as the main importers of steel scrap (BIR, 2019).

In terms of volume, the main exporter of aluminium scrap and copper scrap is the EU, and the main importer of both types of waste is China (BIR, 2016). The highest demand in China is for copper waste and scrap, accounting for 40 per cent of imports in 2018. In the case of aluminium scrap imports, China accounted for 17 per cent of the world total, followed by India at 14 per cent.

2.2.2 Trade in plastic waste

Trade in plastic waste is far less significant than trade in metals, partly because of its low level of recyclability. Plastic is hardly recycled due to the high cost of the process (labour- and energy-intensive). In addition, the costs of producing virgin plastic from crude oil are lower. Different processes are required for recycling different types of plastics and the resulting secondary raw material has a lower quality than virgin raw material and, therefore, cannot replace it in all its uses. Currently, the global recycling rate of plastic fluctuates between 14 per cent and 18 per cent. Europe has the highest recycling rate (30 per cent) (OECD, 2018b).

The low recycling rate implies that this waste is of little value, which in turn results in its reduced collection and commercialization, despite its large global presence. Plastic waste accounts for approximately 12 per cent of all solid waste globally, an estimated 242 million tonnes in 2016 (World Bank, 2020). It is estimated that only a small percentage (4 per cent in 2015) is exported (OECD, 2018b).

For several years, the main exporter of plastic waste was the EU, and the main importer was China. However, as of 2018, China banned imports of various types of plastics. As a result, global exports were basically halved: from monthly shipments of 1 million tonnes in 2016 to 500,000 tonnes in 2018. Several other Asian countries also imposed restrictions, leading to a second drop in imports since mid-2018 (Greenpeace, 2019).

The excessive plastic waste has resulted in a new clandestine trade. Since January 2018, there has been an illegal trade in plastic waste involving transit through several countries to conceal its origin. It is destined for countries in South and Southeast Asia, as well as Eastern European countries. In the receiving countries, the illegal treatment of this waste has increased through unauthorized recycling facilities. The *modus operandi* is to ship plastic waste under a false declaration stating, for example, that the content is plastic raw material (Interpol, 2020). Concerns about illegal trade extend to Africa and LAC.

2.2.3 Trade in Waste Electrical and Electronic Equipment (WEEE)

Metal and plastic waste comes in part from electrical and electronic equipment that has reached the end of its life. Several WEEE contain toxic additives or hazardous substances, such as mercury, brominated flame retardants (BFRs) and chlorofluorocarbons (CFCs) or hydrochlorofluorocarbons (HCFCs), making them dangerous to handle. International trade in this type of waste usually originates from countries where treatment of such waste is highly regulated and is exported to countries with few specific regulations, allowing for greater flexibility in the management of such waste and lower costs, but associated with greater risks to human health and the environment (Ilankoon et al., 2018).

Some studies indicate that between 7 per cent and 20 per cent of WEEE generated within developed countries, such as the United States or some European countries, is exported. Some of these goods are exported as used products to be sold, or repaired and then sold, in developing countries; others are catalogued as scrap. It is estimated that a significant share of such products is exported illegally (Forti et al., 2020). The 2022 Edition of the Harmonized System will facilitate the monitoring of this trade flow as it includes new specific codes for WEEE products.

In recent years, some exports from developing countries to developed countries of valuable waste (such as memory cards), which form part of certain WEEEs, have been detected (Forti et al., 2020). In these cases, the products are exported due to lack of appropriate technologies in developing countries to recover the metals incorporated in these parts and pieces. The recovery of metals from WEEE is referred to as ‘urban mining’.

2.2.4 Considerations on trade in other sectors

In the wood, paper and cardboard mega-industry, shipments of paper for recycling can be highlighted. The main purpose of paper and cardboard recycling is the production of cellulose pulp which is used to manufacture paper and cardboard. In 2018, more than half of all paper and cardboard produced worldwide contained some recycled material. In the same year, the United States processed more than two-thirds of the paper available for recycling internally, while exporting the rest to Mexico and other countries (ISRI, 2020). In Asia, paper and cardboard production used up to 72 per cent recycled content. Europe achieved an average rate of 54 per cent, while in North America, it was 20.7 per cent, and in LAC, 5.4 per cent (BIR, 2020).

The agriculture and food mega-sector includes waste from mostly the food processing industry, which has lost the essential characteristics of the original material. Part of this waste is used for animal feed, another part as input for new products such as fertilizers, energy and biomaterials or biomolecules that require greater value addition. On average, half of the waste generated in the world is organic (Kaza et al., 2018). Because of the characteristics of these wastes (rapid decomposition), they are not a relevant part of international trade flows, and their treatment, when it exists, is mostly carried out locally.

The textile and leather mega-industry is also characterized by a low recycling rate. Only 13 per cent of textile waste is recycled in some form, with the majority of applications being of lesser value, for example, as insulation material, cleaning cloths, and filling for mattresses or furniture. Less than 1 per cent of the material used to produce clothing is recycled into new clothing (Ellen MacArthur Foundation, 2017). The recovery of raw material from clothing or other products of this industry is difficult due to the limited technology available and the complexity of recovering the natural fibres (mainly cotton) and synthetic fibres (mainly polyester).

In the garment industry, trade in used or second-hand goods is more prevalent. In fact, the largest destination for used clothing from developed countries is exported to developing countries (figures not included in this report). In the EU, about 5.8 million tonnes of textiles are discarded each year. Only around 10 per cent of collected used garments are reused within the region of recollection. The majority is exported, first to Eastern Europe for sorting and then to Africa and Asia for reuse (European Topic Centre on Waste and Materials in a Green Economy, 2019). About

45 per cent of textile recycling in the United States consists of sending used clothing overseas. Another 30 per cent entails the reconditioning of second-hand clothing, and the remaining 20 per cent is used as inputs for parts and pieces in the automotive and decoration industry, among others (ISRI, 2020).

2.3 The commercial circuits of waste are concentrated in Europe and Asia

About 40 per cent of global waste exports and imports in terms of value were linked to the EU in 2017–2018 (see Figure 5 and Figure 6). Over the last two decades, Europe’s relative share of global exports decreased, while that of the United States increased. In terms of imports, Europe’s share also decreased, while Asia’s increased, especially during the first decade of this century. Since China’s import restrictions in 2018, an increase in the rest of the world’s share of waste imports has also been observed.

Figure 5 Selected regions: Participation in global waste exports in value, 2002–2003, 2011–2012 & 2017–2018

(in percentage)

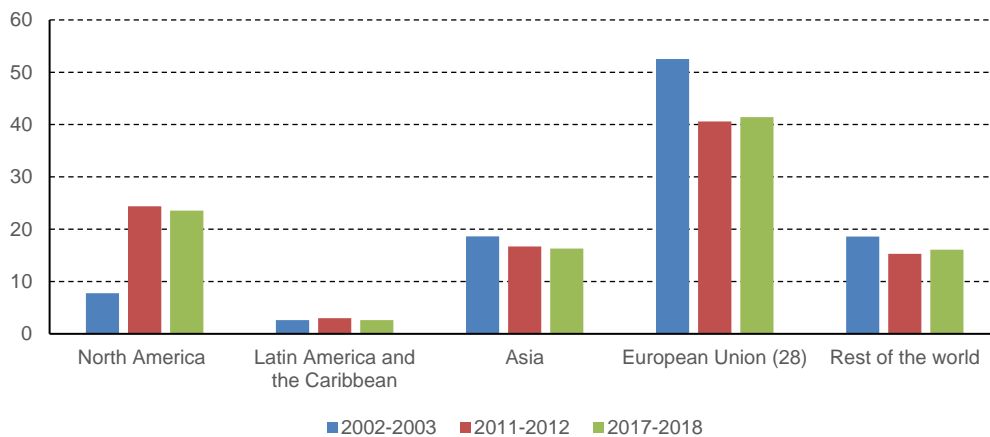

Source: Prepared by the authors, based on BACI/CEPII

Figure 6 Selected regions: Participation in global imports of waste in value, 2002–2003, 2011–2012 & 2017–2018

(in percentage)

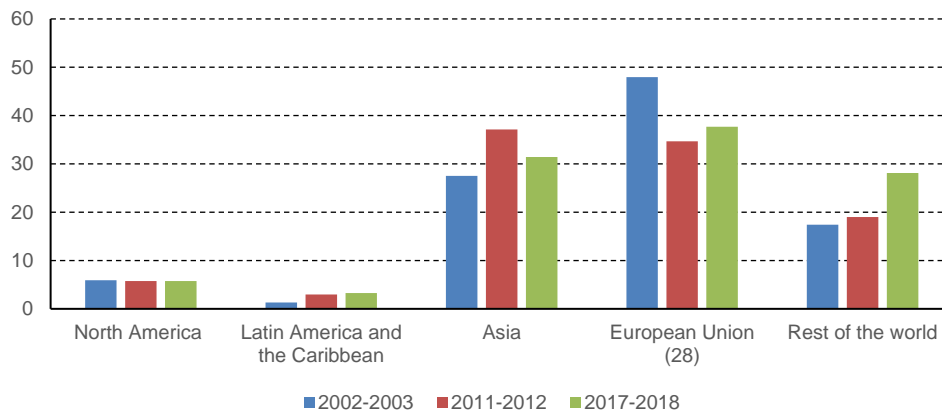

Source: Prepared by the authors, based on BACI/CEPII.

The EU exports most of its waste to China and Turkey⁹. For many years, China offered competitive prices for the purchase of plastic waste, and thus quickly became the main importer of plastic waste from the EU. Europeans also had low transport costs since they used the returning ships that had arrived with goods from China to ship the waste back. European recycling targets were thus being met (Joltreau, 2019). European exports to Turkey nearly tripled between 2002 and 2018, facilitated by the creation of the Customs Union between the two entities (Kettunen, Gionfra, & Monteville, 2019). Following China’s restrictions on waste imports, discussions began on the economic and environmental costs of processing such waste within the European region. The lack of internal capacity in Europe to convert its own waste into resources became very evident.

The United States tripled its share of waste exports between 2002–2003 and 2011–2012. This increase in exports coincides with the increase in imports to China of such goods. In fact, following China’s entry into the World Trade Organization (WTO) in 2001, trade with the United States grew significantly, with waste increasing the most among non-manufactured products, surpassed only by shipments of agricultural products. Between 2000 and 2011, shipments of waste from the United States to China rose in value by more than 15 times, representing 11 per cent of total shipments to the country, concentrating on scrap metal and paper waste. The incentives that

⁹ In its statistics, the EU has restricted the list of waste for recycling those materials identified as critical for its future development, whose local production does not meet its demand. For this reason, the figures used in their analysis are not comparable with other analyses, including this one.

generated an increase in shipments to China are high prices of virgin raw materials, strong demand from the Chinese construction industry and low labour costs in the country (Casey, 2012).

China's tremendous economic growth from 2000 onwards, along with the onset of its trade openness, made it a key player in global waste trade. In addition, the strong promotion of the circular economy¹⁰ was one of the consequences of the environmental impacts generated by the economic growth. The size of its market generates high demand for virgin and secondary raw materials, with their consumption growing every year. In 2010, China became the main importer of copper scrap. It is the country with the highest production of copper from secondary materials (BIR, 2016). Although it is not the world's largest importer of steel scrap, 20 per cent of its steel production comes from scrap (BIR, 2019). China was by far the largest importer of plastic waste in the world until 2017. Between 2016 and early 2018, its monthly imports of plastic waste dropped from 600,000 to 30,000 tonnes (Greenpeace, 2019).

Africa and LAC only marginally participate in global waste trade, thus remaining outside the large formal global recycling circuits. Yet there is growing concern about the increase, particularly in Africa, about illegal waste trade.

In the Rest of the World group (which represents between 15 per cent and 20 per cent of exports and imports), Turkey's share stands out as the largest steel scrap importer in the world (Egypt and Pakistan, among others, are also included). Among the main exporters from the Rest of the World group, Russia, Switzerland and the United Arab Emirates stand out.

2.4 The LAC region has minimal participation in global waste trade

2.4.1 Variation in LAC's waste trade with the world

In 2017–2018, LAC accounted for only 2.6 per cent of global waste exports and 3.3 per cent of global waste imports (see Figure 5 and Figure 6). These shares are approximately half of its shares in global trade in all goods.

The volume of regional waste exports grew at a similar rate as the world total between 2002 and 2018, while regional imports grew faster than the world total (see Figure 7). As a result, between 2002 and 2018, the region went from being a net exporter to being a net importer of waste in terms of volume¹¹. The region's waste trade balance in terms of value is almost level. In 2018, regional waste exports totalled USD 3.8 billion and imports amounted to USD 3.3 billion.

¹⁰ The first law on the circular economy dates from 2008, although specific programs promoting the same objectives existed previously.

¹¹ This increase in import growth coincides with growing waste exports from the United States, which is the main origin and destination of waste trade in the region.

Figure 7 Latin America and the Caribbean: Exports and imports of waste, 2002–2018

(in thousands of tonnes)

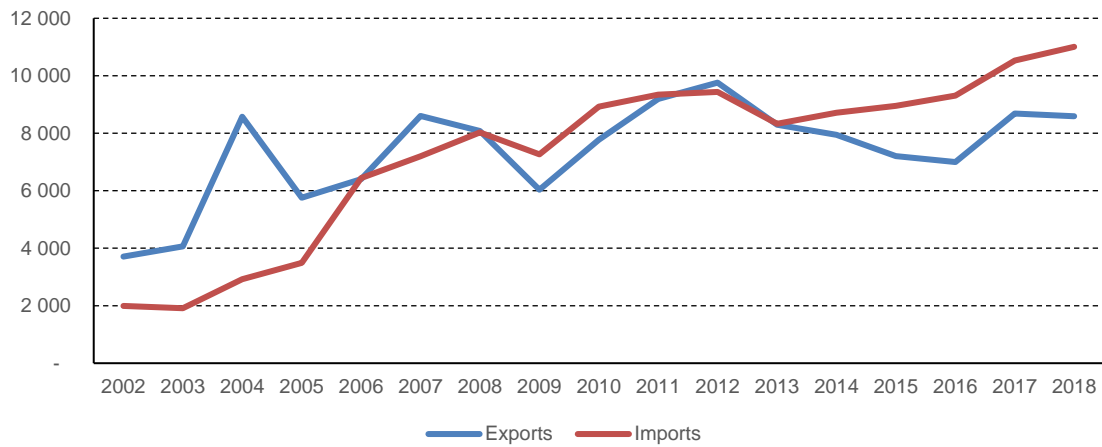

Source: Prepared by the authors, based on BACI/CEPII

Regional exports of waste in terms of value are concentrated in the minerals and metals mega-industry, while regional imports are somewhat more diversified. In this second flow, the agricultural and food mega-sector, as well as wood, paper and cardboard waste, have a relevant presence. In both exports and imports, the shares of plastic and textile waste are lower, as is the case in global flows.

The region’s main waste trading partner is the United States, which in 2018 in terms of value accounted for 43 per cent of exports and 68 per cent of imports. In fact, regional trade in waste is centred around Mexico and the United States. The scrap metal trade between the two countries positions Mexico as the only one in the region in international rankings (BIR, 2019; BIR, 2016). China ranks second as a trading partner, accounting for 23 per cent of exports and 4 per cent imports. The EU ranks third with a 20 per cent share of exports and 3 per cent imports. These three markets are also the most relevant for the region’s total trade in goods.

In 2018, waste exports to (in decreasing order) the United States, China and the EU accounted for 87 per cent of total waste shipments in terms of value. In all three cases, mineral and metal waste represented the bulk of shipments (87 per cent, 95 per cent and 73 per cent, respectively). Exports to the United States also included the chemical and plastic mega-industry (9 per cent of total shipments). Exports to the EU included agricultural and food waste (17 per cent). Exports to China include a low amount (5 per cent) from the wood, paper and cardboard mega-industry (see Figure 8).

Figure 8 Latin America and the Caribbean: Waste exports to main destinations by mega-industries, 2018

(in millions of USD)

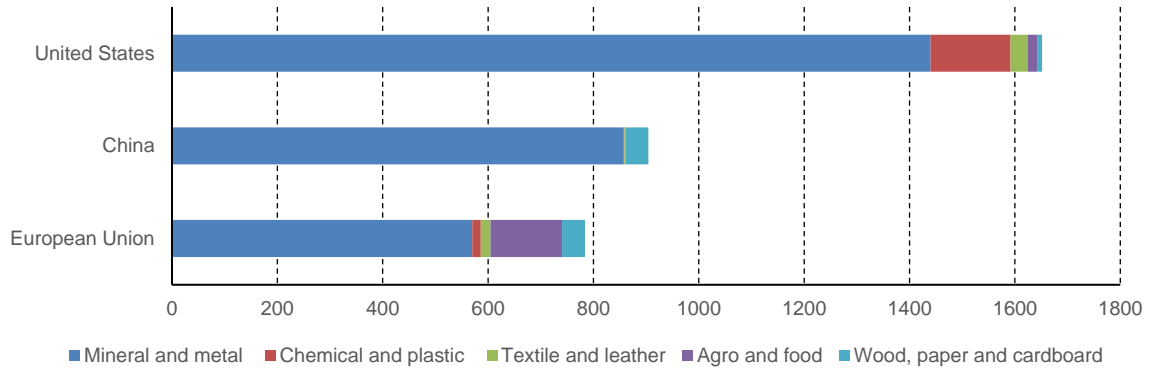

Source: Prepared by the authors, based on BACI/CEPII.

In the case of waste imports, the three main trading partners accounted for 75 per cent of total imports in 2018. However, the main importer, the United States, accounted for a much larger share than in the case of exports. The composition of imports from the United States is more diversified, with approximately half corresponding to metal waste, 30 per cent to agricultural and food waste, and 18 per cent to imports from the wood, paper and cardboard mega-industry (see Figure 9).

Figure 9 Latin America and the Caribbean: Waste imports from main origins by mega-industries, 2018

(in millions of USD)

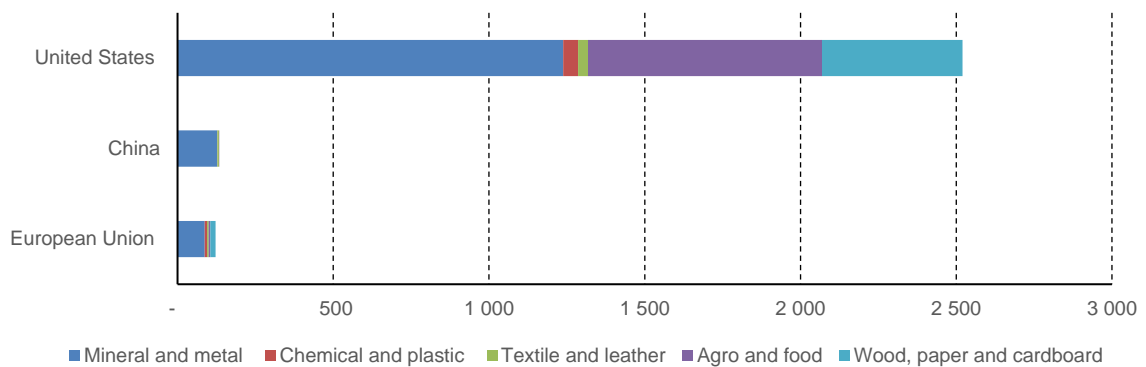

Source: Prepared by the authors, based on BACI/CEPII

2.5 Intraregional trade in waste is low and diversified

The share of intraregional trade in waste is similar to that of the region’s total trade in waste as compared to the share of total trade. In 2018, waste exports to the region represented 10 per cent in terms of value and 19 per cent in terms of volume of total shipments, while imports represented 13 per cent of the total value and 15 per cent of the total volume. The development of intraregional exports in terms of value follows the trend of global shipments (see Figure 10 A)

Figure 10 Latin America and the Caribbean: Intraregional exports by mega-industries, 2002–2018

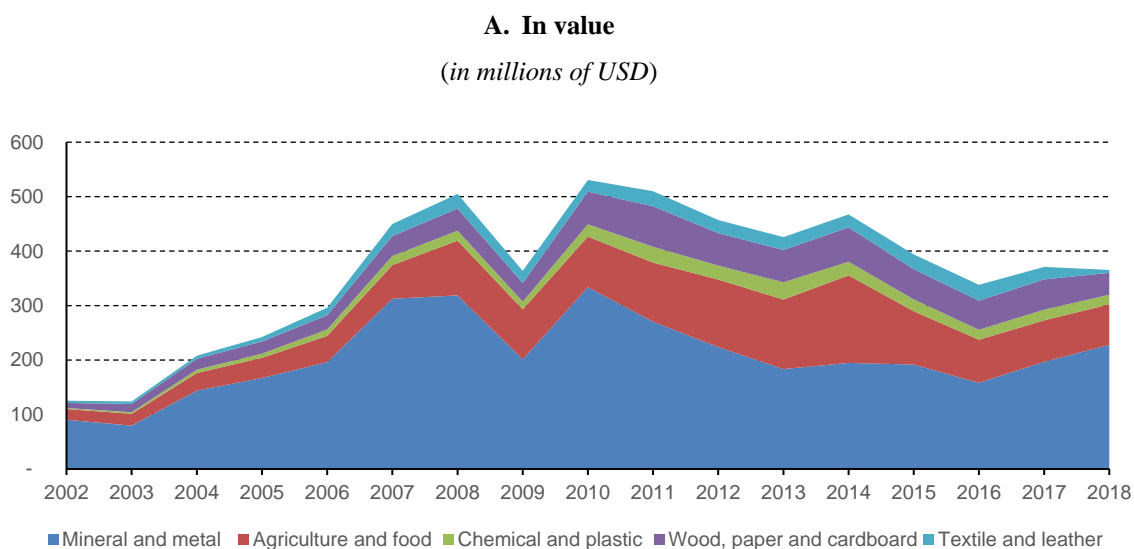

Source: Prepared by the authors, based on COMTRADE.

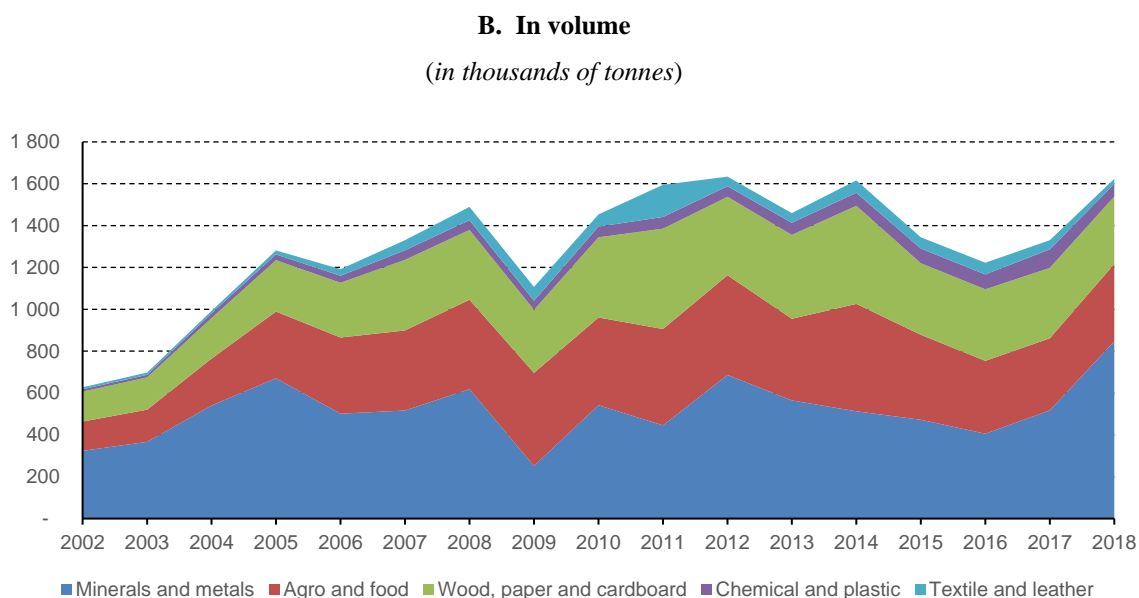

Source: Prepared by the authors, based on BACI/CEPII.

The composition of intraregional trade in waste is more diversified than the region's trade in waste with the rest of the world (see Figure 10 B). By mega-industry in 2018, minerals and metals accounted for 62 per cent of the value and 52 per cent of the volume of intraregional exports; agriculture and food accounted for 20 per cent of the value and 23 per cent of the volume; and wood, paper and cardboard for 11 per cent of the value and 20 per cent of the volume.

The main exporters of waste to the LAC region in terms of volume are (in decreasing order) Brazil, Argentina and Mexico. Of these, Brazil and Mexico's exports primarily consist of scrap metals, while Argentina's exports mainly comprise agricultural and food waste. The main importers are (in decreasing order) Colombia, Peru and Ecuador. In these three cases, scrap metal purchases predominate (see Annex 2).

Some specificities in trade can be distinguished at the sub-regional level. Metal trade has both suppliers and buyers in South America, as well as in Mexico and Central America, which implies the existence of a widespread recycling industry in the region. The main exporters were (in decreasing order) Brazil, Mexico and Chile (representing 61 per cent of total exports), while the main importers were (in decreasing order) Colombia, Guatemala and Brazil (representing 45 per cent of total imports).

Agricultural and food waste trade is concentrated in South America, a large agricultural producer. Argentina accounts for 60 per cent of exports, followed by Bolivia (Plurinational State of) (14 per cent) and Chile (6 per cent). The three main importing countries were Uruguay (39 per cent), Chile (22 per cent) and Paraguay (8 per cent). Meanwhile, exports from the wood, paper and cardboard mega-industry, which are more diversified at the country level, range from Central America to South America, where a recycling industry for these types of goods has been established. The main exporters were Guatemala (15 per cent), Costa Rica (13 per cent) and Nicaragua (9 per cent), while the main importers were Ecuador (16 per cent), Colombia (15 per cent) and Peru (12 per cent).

3 Towards circular industries

3.1 The mineral and metal recycling industry

Given its predominance in global trade in waste, it is relevant to further analyse the mega-industry of mineral and metal waste. Based on the analysis of trade data in Section II, the trade of steel, aluminium and copper waste represents both the highest volume and value of global and regional waste trade flows. The cases of these materials are analysed below, given that the application of the circular economy in these industries entails significant environmental benefits, and simultaneously offers interesting economic opportunities.

It is estimated that between 70 per cent and 75 per cent of steel, aluminium and copper produced in the past are still in use (EuRIC aisbl, 2020; International Copper Association, 2017). These materials have not been discarded, but rather reinserted into various other production processes. This means that a recycling industry has been built around them. This industry obtains its raw materials mainly from goods at the end of their life (old scrap) and waste generated in production processes (new scrap) (ISRI, 2020).

Up to 69 elements of the periodic table are contained in WEEE, making it a potential source of inputs for secondary raw materials. Iron, aluminium and copper represent most of the total weight of materials found in such waste. In 2019, 53.6 million tonnes of e-waste were generated worldwide, an average of 7.3 kg per capita. By 2030, this figure could reach 74.7 million tonnes. There is great potential for recovery of the metals contained in WEEE. For example, only considering the cases of aluminium and copper, estimates for 2019 show that in an ideal scenario, 3,046 kt of aluminium could be recovered, equivalent to USD 6,062 million and 1,808 kt of copper equivalent to USD 10,960 million. However, only 17.4 per cent of total WEEE waste in the world is currently recycled (Forti et al., 2020).

A study by the United Nations University (2015) indicates that the main generators of WEEE in the region are (in decreasing order) Mexico and Brazil, but that in the production of waste per capita (in decreasing order) Chile and Uruguay take the lead. The study also shows that in 2014 the global average generation of WEEE waste per capita was 5.6 kg, while for the same year, the generation of WEEE waste per capita in LAC was 6.6 kg. This figure is expected to increase every year (UNU, 2015).

Therefore, the significance and opportunities for adequate management and valorization of this type of resources are increasing in the region. In countries such as Chile and Uruguay, several local companies are already managing these wastes, for example, Werba and Midas. However, a series of challenges have been identified for this industry, since, as mentioned above, there are certain economic, technological and social factors that need to be present to ensure the feasibility

and effectiveness of the recycling industry and transition towards a circular economy (UNEP, 2011).

Both recycling and mining production are projected to increase at the same rate until 2030. Thereafter, recycling is expected to increase at a faster rate, driven by infrastructure growth in developing countries. As the availability of recyclable materials and the ability to convert them into secondary raw materials increases, so will recycling. Until 2060, the production of secondary iron and steel is expected to remain constant in relation to virgin raw materials. However, the production of aluminium, copper and other recycled metals is likely to decrease because their processing costs are higher than those of steel, and the cost of labour is expected to increase, even as total recycling costs decrease. This, in a scenario where there is no strong intervention to encourage recycling (OECD, 2019). Therefore, to achieve greater circularity in these industries and to take advantage of the benefits this entails, public and commercial policies that encourage and support the recycling industry and transition towards a circular economy become fundamental.

The circularization of these industries would not imply the disappearance of the extractive sector, since the current use of secondary raw materials cannot supply the continuously growing demand. Within this scenario, circularization is presented as a complement rather than an alternative. It is therefore relevant to delve into the implications of taking this path for the region. At the productive and economic level, the possible consequences may vary based on the different countries' profile, depending on whether they are importers or exporters of the products from these industries. This is especially interesting for countries that export products from the extractive sector, since the sale of scrap metal, even if not processed, has higher margins of profitability than the sale of ores and their concentrates, and, at the same time, entails significant environmental benefits. For importing countries, or for those without a mining industry, it also represents an opportunity to capture value and export it, or keep it for domestic use, thus reducing their reliance on the international market.

Finally, a greater circularization of these industries in the region could have a significant social impact, contributing to the formalization of the recycling industry by providing it with a stronger and more consolidated base. In LAC, informal recyclers currently have a large presence and contribute to the recycling industry. However, since most of them are outside the formal sector and carry out the work in a very precarious manner, it is difficult to calculate their contributions. Growth in the recycling industry and in the recovery of metal waste can create new sources of employment and the generation of skills for people who currently informally participate in this industry, simultaneously promoting access to decent work and greater security in various ways (UNEP, 2018).

3.2 Environmental and economic incentives for the circularization of aluminium

Aluminium is a permanent material, meaning its properties do not deteriorate as it is reused or recycled. Inputs for aluminium production can come from primary or secondary sources.

The production chains of primary and secondary production differ (see Figure 11). In the former, the chain begins with the mining of bauxite. Given its abundance, the value of bauxite is significantly lower than that of other minerals. In the industry, it is chemically processed and converted into alumina (aluminium oxide). Finally, the alumina is smelted to become primary aluminium, which is then used in a variety of manufactured products. Electrical energy represents between 20 per cent and 40 per cent of the cost of primary aluminium production (The Aluminium Association, n.d.). In the latter case, the chain starts with the collection and classification of aluminium scrap, which may come from waste generated during primary production or from the recovery of products that have been discarded and contain aluminium. The scrap is then placed in furnaces and melted at high temperatures; the resulting product is molten aluminium in its liquid state.

Figure 11 Aluminium production chain

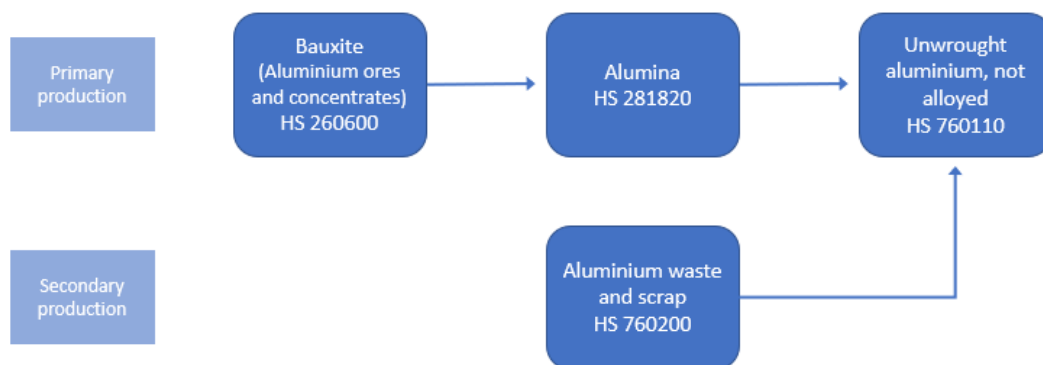

Source: Prepared by the authors, based on the Harmonized System 2002 Edition.

Note: The diagram serves to illustrate, in a simplified form, the different products involved and/or resulting from the aluminium production process and their corresponding classifications in the Harmonized System 2002 Edition.

In the region, Guyana, Brazil and Jamaica are among the world's leading exporters of bauxite. In the case of world imports, the region's only country in the top ranks is Argentina in 12th place in 2018. Similarly, Brazil and Jamaica also stand out as top global exporters of alumina. However, as regards the global exports and imports of unwrought aluminium, it is observed that the countries that export primary inputs do not play a significant role in the exports of unwrought

aluminium and instead import this product. This may indicate that there is a lack of vertical integration in the countries' aluminium value chains, these being focused on exporting low value primary inputs originating in the extractive and refining industries, and instead importing higher value-added products with a stronger technological component.

Regarding aluminium waste and scrap in the region, only Mexico ranks 10th in exports with an approximate value of USD 382 million¹². Brazil is not one of the main exporters of this product, but ranks 15th among importing countries, since in 2018, it imported nearly USD 246 million in aluminium waste and scrap. Similarly, in 2018, Mexico ranked 16th among world importers of this good. Central American countries do not play a significant role in the global trade of primary or secondary inputs. In the case of scrap metal exports from these countries, aluminium waste and scrap lead, of which approximately 60 per cent is exported to North America and, in second place, to Asian countries. Panama is considered the main collection site for metal exports (ferrous and non-ferrous) in the Central America region (IADB, 2016).

Aluminium recycling is environmentally beneficial for several reasons. The use of aluminium scrap helps reduce CO₂ emissions by up to 95 per cent compared to the production of primary aluminium. In addition, each tonne of recycled aluminium scrap saves eight tonnes of bauxite and 14,000 kWh of energy. The use of aluminium scrap also contributes significantly to the reduction of waste in landfills (EuRIC aisbl, 2020).

The secondary production of aluminium and the recovery of waste and scrap seems more profitable than primary production for two reasons. First, the unit export value of aluminium waste and scrap is much higher than that of alumina (see Figure 12). This reflects the fact that there is higher value capture in the export of this product than in alumina exports. Also, secondary production uses only 5 per cent of the energy required to produce primary aluminium, making it a highly attractive alternative for countries with high energy costs (European Aluminium, 2020).

¹²According to the United Nations Commodity Trade Statistics Database (COMTRADE). Retrieved from: <https://wits.worldbank.org/>.

Figure 12 Unit values of world exports of alumina and aluminium waste and scrap, 2002–2018
(in USD per kilogramme)



Source: Prepared by the authors, based on COMTRADE data.

Note: In the Harmonized System 2002 Edition, alumina corresponds to Code 281820 and aluminium waste and scrap to Code 760200.

The circularization of aluminium at the internal level also offers other benefits. The valorization and recycling of this product reduces reliance on imports of primary inputs, simultaneously promoting a decoupling of resources coming directly from the extractive sector, such as bauxite. Japan, for example, no longer produces primary aluminium, but instead focuses exclusively on the recovery of its waste and scrap (Sauvage, 2019).

For the above reasons, the share of world exports of aluminium waste has been similar to that of alumina for several years. Furthermore, secondary aluminium production at the global level accounts for twice as much as primary aluminium production, being the main source of inputs for total aluminium production (EuRIC aisbl, 2020). This reinforces the message that this material, catalogued as waste and scrap, is instead a valuable input and resource. However, in the case of LAC, the region is still preoccupied with the commercialization of inputs from the extractive sector, missing out on a significant opportunity to capture value.

3.3 Environmental and economic incentives for the circularization of copper

Copper is also a material with virtually infinite potentials for reuse, as its properties are not lost when it is reprocessed.

Primary copper production begins with surface mining, underground mining or leaching for the extraction of copper ore, which is then transported and treated in processes such as hydrometallurgy or pyrometallurgy, depending on whether the ore is oxidized or sulfurized. Oxidized ores undergo the hydrometallurgical process for the extraction of copper metal and the production of refined copper cathodes. Sulfide ores undergo the pyrometallurgical process, which involves crushing, grinding and flotation to extract copper concentrate. Copper mattes and blister copper are obtained from this concentrate after a smelting stage. The molten copper then undergoes a refining process to obtain refined copper cathodes with 99.9 per cent purity (Hanni & Podestá, 2019).

On the other hand, the secondary production process is divided into four stages: cleaning and pre-treatment of the scrap, smelting, alloying and casting. The pre-treatment stage consists of the cleaning and consolidation of the scrap for smelting; this stage can be carried out manually, mechanically or through hydrometallurgical or pyrometallurgical processes. Smelting consists of exposing the scrap metal to high temperatures for treatment, separation and purification of certain metals. Finally, alloying involves the incorporation of one or more metals into copper to obtain the desired qualities of the final product of this process (U.S. Environmental Protection Agency, n.d.).

Among the materials involved in the primary production of copper (see Figure 13), it should be noted that copper ore is rarely exported as most of its content is rock with no commercial value. Similarly, copper mattes do not play a role in international trade since there are no intermediate products from the process. The trade of unrefined copper and unrefined copper anodes also plays an insignificant role in the international market. Copper concentrates and refined copper are the products that assume a leading role in international trade (OECD, 2015).

According to the International Copper Study Group, global demand for copper has tripled over the past 50 years. It is estimated that this demand will continue to increase given population growth, productive innovations, economic development (ICSG, 2019) and the transition to renewable energy. While copper recycling cannot completely replace primary production, the valorization of this waste provides opportunities to move towards greater circularity and a (partial) decoupling from the extractive sector.

Chile and Peru are among the main exporters of copper in the world. In 2018, Chile was the world's leading exporter of copper ores and concentrates as well as refined copper. During the same year, Peru was the second largest exporter of copper ores and concentrates in the world, and the eighth largest exporter of refined copper. In the case of Peru, the difference in its position as an exporter of minerals and concentrates compared to its position in refined copper exports can be explained by the lack of refinery and smelter-related technologies (Hanni & Podestá, 2019).

Figure 13 Copper production chain

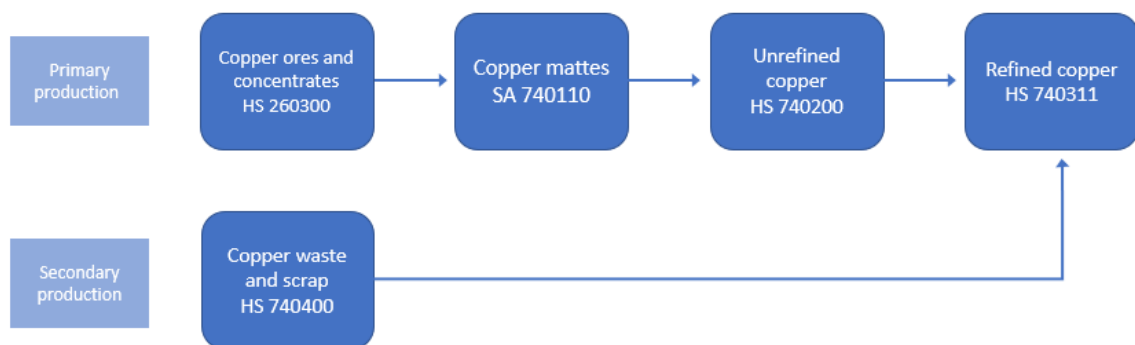

Source: Prepared by the authors, based on the Harmonized System 2002 Edition.

Note: The diagram serves to illustrate, in a simplified form, the different products involved and/or resulting from the copper production process and their corresponding classifications in the Harmonized System 2002 Edition.

Other countries in the region also figure among the top ten global exporters of copper ores and concentrates, such as Brazil and Mexico in 6th and 7th place, respectively. However, these countries are not among the major exporters of refined copper. In the case of Brazil, a similar trend as in the aluminium chain is detected: the country plays a significant role in the export of the primary input, but is a net importer of the processed product, in this case, refined copper. Regarding copper waste and scrap exports, of all LAC countries, only Mexico ranked 10th among the world exporters in 2018. No country from the region appears among the main importers of this product¹³.

Copper recycling has several environmental advantages. This process uses 85 per cent less energy than required for primary production and avoids approximately 40 million tonnes of global CO₂ emissions (Copper Alliance, n.d.). On the other hand, the primary production process requires large amounts of water. Also, the concentration of metal waste in landfills and/or primary

¹³ According to the United Nations Commodity Trade Statistics Database (COMTRADE). Retrieved from: <https://wits.worldbank.org/>.

production waste not adequately managed can result in the contamination of soil and water sources (McCarthy & Börkey, 2018).

As of 2015, the unit value of copper waste and scrap exceeded that of exports of copper ores and concentrates (see Figure 14). The increase in the unit value of copper waste and scrap exports makes activities such as urban mining even more attractive, even for countries primarily engaged in traditional mining and extraction.

Moreover, secondary production plays an important role as a source of supply: in 2017, an estimated one-third of the world’s copper came from recycled copper (ICSG, 2019). Within the EU, approximately 44 per cent of copper demand is supplied from recycling sources (EuRIC aisbl, 2020). It is worth noting that trade in copper waste and scrap takes place between wealthy countries: the main exporters and importers include countries such as the United States, Germany, Japan, among others.

Figure 14 Unit values of global exports of copper waste and scrap and copper ores and concentrates, 2002–2018

(in USD per kilogramme)

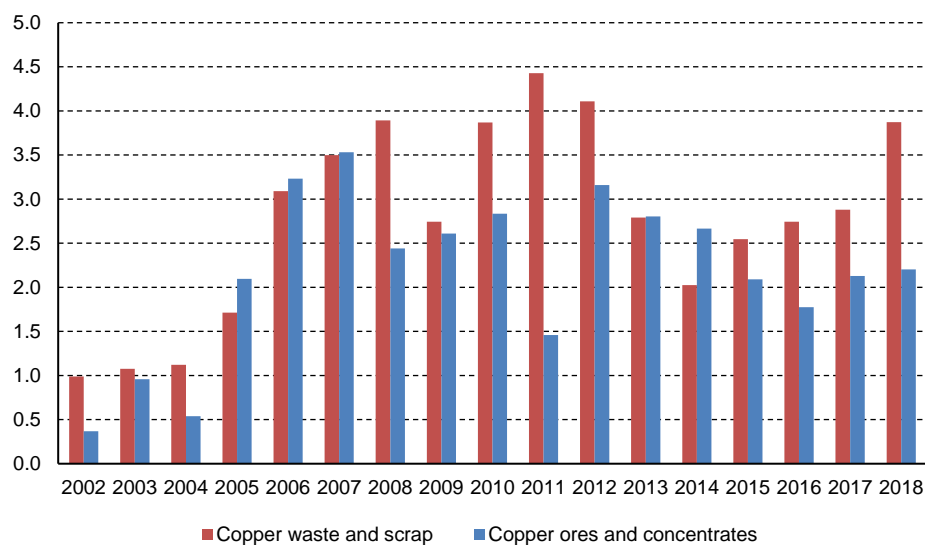

Source: Prepared by the authors, based on COMTRADE data.

Note: In the Harmonized System 2002 Edition copper waste and scrap corresponds to Code 740400 and copper ores and concentrates to Code 260300.

Although the recycling of copper (and similar metal) waste and scrap presents interesting opportunities and an alternative (to some extent) to the extractive model, it should be noted that the actual value of waste and scrap varies and depends on the quality of the scrap and copper content in it.

4 Necessary coordination of trade policy and circular economy agendas

Trade policy can have both a negative and positive impact on international waste flows and others related to the circular economy. On one hand, trade policy can create obstacles that deter progress towards the circular economy, insofar as it impedes or discourages certain trade flows. On the other hand, it can also facilitate trade in waste and some used and remanufactured goods by improving market access, standardizing regulations, and/or incorporating trade facilitation measures.

At the same time, the agendas for promoting the circular economy can assign an active role to trade measures in order to, for example, reach the necessary scales, take advantage of the technological development of neighbouring or nearby countries, and generate spaces for cooperation with trade partners. This coordination of agendas, and especially international cooperation around them, can encourage the incorporation of increased circularity in processes and products, as well as greater availability of secondary raw materials.

Below, various aspects of circularity that are analysed from a trade perspective within the framework of the WTO and other trade agreements, are identified. The potential effects on trade of circular economy initiatives, such as the EU strategy and circularity standards, are discussed as well. The latest reforms of the Basel Convention, which affect both agendas, are also highlighted.

4.1 The WTO indirectly addresses the circular economy

The main points of intersection between international trade and the circular economy agendas within the WTO relate to domestic measures applied by members that aim at achieving environmental improvements and that have or may have an impact on trade. These measures are notified to the WTO. There are instances that allow for a better understanding of their scope and impact (such as the periodic trade policy reviews to which WTO members are subject), as well as for the resolution of trade disputes that may arise as a result.

In general, developing countries adopt “defensive” measures focused on imports, while developed economies tend to concentrate on regulating or supporting activities that encourage a shift to green or circular trade models (WTO, 2020). Between 2009 and 2017, 65 members implemented 370 measures in relevant areas of the circular economy, half of which were related to recycling. Of these, 16 per cent involved the reuse and repair of goods, 11 per cent were measures concerning aspects of biodegradability, another 11 per cent focused on waste for energy production, and 4 per cent related to reconditioning and remanufacturing (Steinfatt, 2020).

Between 2009–2018, 301 recycling-related measures were notified to the WTO, of which 15 related to LAC (see Figure 15). The main group of measures (51 measures) related to preferential taxes or tax credits to encourage recycling and/or the reuse of products and materials. Slightly over 10 per cent (32 measures) are import licenses or similar that are requested upon the entry of waste. Another 25 measures are technical regulations seeking to protect the environment and regulate manufacturing processes. Most of the measures notified by the LAC region (6 measures) are technical regulations. The country with the highest number of notifications is Costa Rica with three, followed by Ecuador with two notifications.

Figure 15 Selected regions: Number of recycling-related measures notified to the WTO, 2009–2018

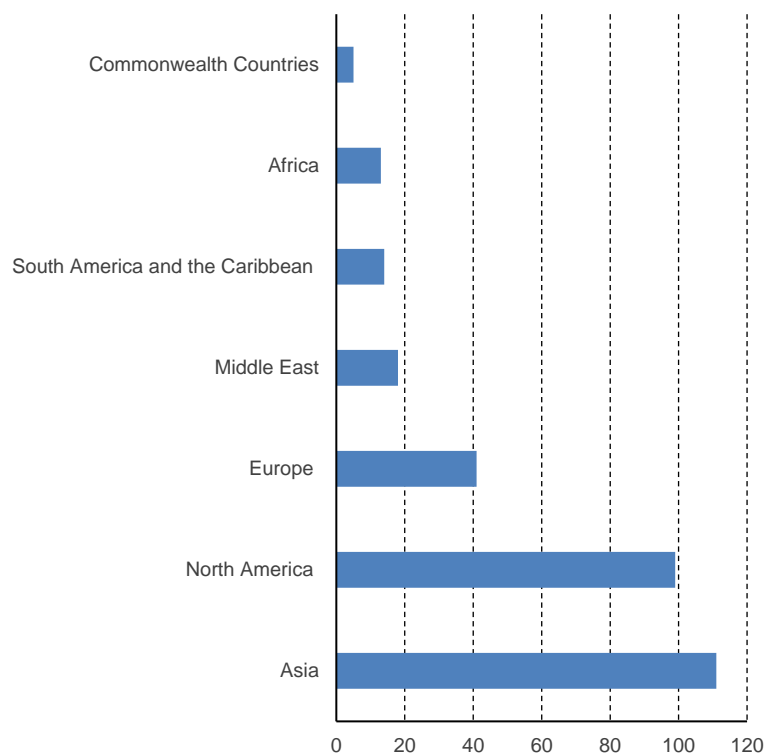

Source: Prepared by the authors, based on the WTO’s Environmental Database [on-line] <https://edb.wto.org/notifications> (Retrieved 31 July 2020).

In the WTO Committee on Trade and Environment, measures around the circular economy that influence market access, environmental labelling and related international negotiations have been reviewed. Based on these issues, a series of proposals were generated for the WTO to actively participate in the search for solutions. The proposals are classified as follows: (i) purely commercial aspects (e.g. facilitation of procedures under the Basel Convention, lower tariffs on plastic substitutes, biodegradable and recycled plastics or those derived from bio-based sources); (ii) support for developing countries (e.g. for involvement in circular trade and regarding the lack of domestic infrastructure for this type of trade); and (iii) support in generating a favourable global

climate for a more rapid implementation of the circular economy (e.g. eliminating fossil fuel subsidies, fostering cooperation, and generating an adequate business climate, both in financial and regulatory terms) (WTO, 2019).

4.2 The EU's circular economy strategy has an impact on international trade

4.2.1 The European Green Deal

Within the framework of the “European Green Deal”, the EU proposes designing and implementing instruments to achieve the decarbonization of its economy by 2050. Under this objective, the Circular Economy Action Plan (hereinafter the Plan) and the “Farm to Fork Strategy” stand out. The Plan addresses measures related to the design of sustainable products, key product value chains (WEEE, textiles, plastics, vehicles, packaging, construction and food, water and nutrients), waste management, community, cross-cutting initiatives (linked to financing) and global leadership in the field. These actions will be implemented between 2020 and 2021 (European Commission, 2020). The “Farm to Fork” strategy makes companies responsible for controlling the safety of the food they produce, from its origin to its consumption site. The two strategies are interrelated.

The Plan has two direct impacts on trade in waste between the EU and its partners. On one hand, the EU considers the inclusion of circular economy objectives in the negotiation of trade agreements, be they bilateral, regional or multilateral. On the other hand, the Plan refers to the commitment Europe must assume in the treatment of its waste, ensuring that it is not exported to other countries. In this sense, to promote more sustainable management, it proposes the revision of regulations and restrictions on exports of hazardous waste for the environment and human health.

The European Green Deal also has an impact on access to the European market by promoting the production and import of sustainable products and consumer empowerment by labelling information and introducing new consumer rights. The “Farm to Fork” strategy promotes the consumption of local foods and means greater environmental requirements for imported food products. The implications this policy will have for LAC must be analysed in terms of challenges but also opportunities.

Taking this challenge into consideration, the European Commission analyses the future of foreign trade in its circular economy proposal. It considers that the value chains that make up European companies originate in developing countries. Therefore, if the EU places its bets on a circular future, it is necessary for circular companies to exist in developing countries as well. The adoption of circular practices in different GVCs is a guarantee for the Plan's success (European Commission, 2020). The challenge is to include the circular economy in the international agenda

and to adopt international cooperation actions as a tool for capacity-building and technology transfer, which are necessary for a just transition.

A key tool in European environmental policy is the environmental footprint, which is based on environmental information on GVCs and includes circularity aspects. The tool's methodology is based on the life cycle assessment and allows for the identification, communication and comparison of the environmental impacts of organizations and products. As part of its pilot plan, 11 LAC countries participated in a study on the environmental footprint of coffee. In this process, the greatest challenges involved the lack of local information on the relevant impacts at the cultivation stage, leading to the use of international databases, which often disadvantage producers that adopt sustainable processes. Quantifying the positive environmental impacts resulting from shade-grown production and agroforestry systems also poses a challenge (Olmos, 2019). The main objective is to compete in the European market, not only on price, but also on environmental merits.

4.3 Through its trade agreements and other instruments

The trade agreements negotiated by the EU are what pose a more comprehensive vision of environmental and social issues in relation to international trade. In its latest trade negotiations, the EU has incorporated a chapter on sustainable development, which lists the issues on which joint work will be carried out, and establishes committees to implement the agreements. The involvement of civil society actors is ensured in these instances (European Commission, 2020). In two agreements, the EU has proposed the specific inclusion of the circular economy: in those negotiated with New Zealand and with Mexico (which corresponds to a renewal of the agreement in force since 2000).

The chapter on sustainable development in the trade agreement with Mexico stipulates in its scope and objectives that the parties will promote: i) sustainable development, which encompasses economic development, social development and environmental protection, these being interdependent and mutually reinforcing; ii) the development of international trade and investment in a manner that contributes to the objective of achieving the SDGs; and iii) inclusive green growth and the circular economy so as to foster economic growth while ensuring the protection of the environment and promoting social development. Article 13, which identifies areas for joint work, mentions the promotion of inclusive green growth and the circular economy (European Commission, 2018).

In the negotiation with MERCOSUR and Chile (renewal of the 2003 agreement), the EU's proposals mentioned the circular economy as part of an extensive list of areas of joint work, without highlighting it in their central objectives as in the Mexican case. In the text proposed to MERCOSUR, the following are included: sustainable consumption and production initiatives in line with SDG 12, which include, among others, the circular economy and other sustainable economic models aimed at increasing resource efficiency and reducing waste generation (EU-MERCOSUR, 2019, p.11). In the case of Chile, sustainable consumption and production initiatives are mentioned, including those aimed at promoting the circular economy, green growth and the reduction of pollution (EU-Chile, 2018, p.11).

The circular economy is also addressed in sustainability assessments in trade negotiations, which since 2016 must consider contributions to the greening of the economy. A review of the assessments shows that in all cases, resource use and efficiency as well as waste management are part of the indicators. The circular economy is directly addressed in three reports: the 2017 Transatlantic Trade and Investment Partnership report and, most significantly, the 2018 negotiations with the Philippines and Malaysia. In the latter negotiations, issues such as waste management and marine litter are analysed, and it is suggested that the agreement can help strengthen cooperation with the EU in these areas, generating opportunities for both parties. Special mention is made of the electronics industry (in both cases), as well as the garment industry (Philippines) and the financial services sector (Malaysia) (Kettunen, Gionfra & Monteville, 2019).

In the case of international forums, the European Commission worked within the framework of the Group of Seven (G7) and the Group of Twenty (G20) to promote environmental diplomacy, and followed up on the environmental issues included in the agendas of these forums. Actions to fight marine litter and those concerning the improvement of resource efficiency, for example, sharing knowledge and best practices, can be highlighted (European Commission, 2020).

4.4 Through international cooperation

The EU also integrates the circular economy in its international cooperation. In the framework of the EU-MERCOSUR negotiations, the circular economy is one of the priority sectors to be addressed in the Horizon Europe 2021–2027 programme (RECYT, 2019). Although it is a long-term project, countries have already prioritized circular economy research. On the other hand, the EU has been promoting circular economy projects, sustainable public procurement and innovative and sustainable growth since 2016 in countries such as Chile, Colombia, Mexico and Peru (European Commission, n.d.).

Another example is the Memorandum of Understanding signed between the EU and the People's Republic of China¹⁴ in July 2018, which is valid for a five-year period (EU-China, 2018). Among the priorities for cooperation, the design of regulations that promote the circular economy is highlighted, as is the exchange of best practices for waste management, green value chains and circular investment and financing.

Lastly, the European Commission among its priorities includes actions that promote the circular economy and count on the participation of United Nations programmes, national governments of developed countries and the private sector. Some of these initiatives are the Partnership for Action on Green Economy (PAGE), the Platform for Accelerating the Circular Economy (PACE), the Extractive Industries Transparency Initiative (EITI), the International Labour Organization's Green Initiative, and the Waste and Chemicals Management Programme of the United Nations Environment Programme (European Commission, 2020).

4.4.1 Circularity standards as an instrument to be developed

The industrial world is debating the establishment of circularity standards, either regarding products or their labelling, to promote the circular economy, for example, standards that specify the degree of recyclability of plastics for certain products. To avoid the creation of trade barriers, it is necessary for countries to agree on an assessment at the multilateral level. Companies would thereby have common and clear standards for international marketing, and at the national level, policies could be generated to encourage their use, fostering the circular industry (World Economic Forum, 2020).

In this sense, there are institutions at the international level that have sustainable standards that could serve as a guide to establish a multilateral agreement with minimum compliance standards. These are the International Organization for Standardization (ISO), the American Society for Testing and Materials (ASTM), and the European Committee for Standardization (CEN). At the regional level, the Pan American Standards Commission (COPANT) is the focal point for technical standardization and brings together standardization institutions, promoting their development.

In 2018, a Technical Committee was formed within the framework of the ISO to design guidelines that facilitate the implementation of the circular economy in all activities. The Committee is composed of experts from different countries. The goal is to facilitate decision making for stakeholders (public

¹⁴ China has been promoting the circular economy since 2008, and has been implementing a Circular Economy Action Plan since 2013, prioritizing the following industries: plastics, food, waste, construction and demolition (Ellen MacArthur Foundation, 2020). The potential represented by the cooperation agreement between the EU and China is significant, given the relevance of the parties not only in international trade, but in reference to the shared vision on the circular economy.

and private). The results are expected to contain an integrated vision of the circular economy in user-friendly documents to implement it and avoid the proliferation of standards (ISO, 2019).

It is necessary to differentiate between standards, certification, labels and declarations. Standards are understood to be frameworks that identify certain criteria (in some cases using specified indicators) or specific norms applicable to material goods or services, including packaging. Certification refers to a formal accreditation process which confirms that a given set of (minimum) standards are met. A label describes a logo or seal that highlights the specific characteristics of a product or service (it may or may not correspond to a certification). Declarations refer to claims made by companies about the benefits, qualities or characteristics of their goods and services. It is important to be cautious in the case of declarations, since they can be used for “greenwashing”, a deceptive practice used to market products as environmentally friendly when this is not necessarily the case (UNEP, 2020). For example, there is no standard use of recycling symbols on bottle labels; companies can use them indiscriminately, misleading the public (Changing Markets Foundation, 2020).

Standardization and certification practices are a key tool for promoting circular design and production practices. One such opportunity is the new amendment on plastic waste trade that will be in effect as of 2021 under the Basel Convention¹⁵. To commercialize plastic waste that is considered hazardous, countries will have to present prior informed consent (PIC). This provides notice of the commercialization of the product, the route it will take, the parties’ consent to participate in either the transport or transit of the goods, and confirmation that the plastic waste will receive appropriate environmental management at its destination (Basel Action Network, 2019; World Economic Forum, 2020). Agreeing on global standards and labelling rules at the multilateral level for plastic waste would facilitate the necessary traceability for fair trade, while promoting an industry with a circular production logic and preventing regulations from becoming an obstacle (Kettunen, Gionfra, & Monteville, 2019).

¹⁵ This modification includes plastics in Annex II, with a new entry, Y48, which lists wastes requiring special consideration. The following annexes have also been modified: VIII (with a new entry, A3210, clarifying the scope of plastic waste presumed to be hazardous) and IX (with a new entry, B3011 replacing B3010, clarifying the types of plastic waste presumed to be non-hazardous).

4.4.2 The challenges of harmonization under the framework of the Basel Convention

The Basel Convention regulates the transboundary movements of hazardous waste. This regulation constitutes an international¹⁶ consensus for the classification of hazardous waste and its treatment, allowing the establishment of adequate management at the national level and the objective being the reduction of the transboundary management of this type of waste. The list of products was last updated in May 2019 to include the international commerce of plastic waste as well as WEEE.

LAC is part of this Convention, but not all countries have specific regulations on WEEEs. In consultation with the Basel Convention Coordinating Centre¹⁷, one major challenge identified in the region is the harmonization of definitions and regulations. The first step is to agree on the definition of WEEE (whether it is considered hazardous or not) and to then harmonize their classification. A second challenge is to agree on how this waste will be managed. An example of what should be avoided is the situation of lead-acid batteries. These products are categorized as hazardous products. When the countries in the region ratified the Basel Convention, they prohibited the entry of hazardous waste, including, for a large majority, transit through their land and jurisdictional waters. However, there are reports of illegal commercialization and non-compliance with the required safety standards. Having a common approach to regulations would allow for the establishment of harmonized procedures and the possibility of control. With common regulations, companies would be better able to properly manage materials and there would be tools for effective control of illegal cross-border trade, and the possibility of generating synergies between different sectors and production chains (Forti et al., p.72-73).

Another challenge identified is the development of the necessary infrastructure and capacity for the treatment of WEEE. The BCCC provides technical assistance, but funding for the necessary technological development for regional treatment is insufficient. It is important to note that, in some cases, companies cannot obtain private financing due to prohibitions in the international banking system of access to a credit for technological change in a mercury plant, for example. In

¹⁶ Afghanistan, the United States and Haiti are not part of the agreement.

¹⁷ The Basel Convention Coordinating Centre (BCCC) for Latin America and the Caribbean, based in Uruguay, coordinates with other Centres at the regional level: the Basel Convention Regional Centre for the South American Region –Argentina–, the Basel Convention Regional Centre for the Central American Sub-region including Mexico, Panama and the Basel Convention Regional Centre for the Caribbean Region –Trinidad y Tobago –. At the same time, the BCCC is the Stockholm Convention Regional Centre. This Convention deals with Persistent Organic Pollutants (POPs). These are chemicals that circulate in the world and remain (themselves or their toxic by-products) intact in the environment for long periods of time. The Convention seeks to eliminate POPs produced by direct synthesis and to mitigate the emissions of those that are generated unintentionally. The purpose of the BCCC is to consolidate the cooperation process that allows for the creation and strengthening of capacities and expertise for the implementation of the Basel and Stockholm Conventions.

this sense, by identifying the needs of LAC countries, a regional platform could be developed to find a common path to establish management standards.

From the private sector perspective, members of Werba S.A.¹⁸ agree on the challenges outlined by the BCCC, but also highlight others. On one hand, there is a need for intensified dialogue among all value chain actors, and to ensure traceability to transmit reliable information. It is essential that efforts be increased so that the treatment of the materials that make up a product are considered in the design phase. On the other hand, and without neglecting environmental controls, streamlining the commercialization process by removing excessive bureaucratic barriers is considered necessary. For example, it may occur that cargo authorizations for international transportation are granted in longer periods than those granted by the cargo permits of a shipping company, generating logistical difficulties.

5 Conclusions and recommendations

5.1 Conclusions

International trade can facilitate the transition to a circular economy in LAC, provided that the incentives are strengthened and the disincentives are mitigated, generating the necessary framework for the promotion of a just circular economy transition at the global level and a more sustainable post-pandemic recovery.

The valorization of waste in production chains depends on its profitability and technical feasibility. International trade promotes economies of scale that many countries in the region lack, which will be adapted to the local comparative advantages. Once valorization is considered profitable, the development of technology and infrastructure to implement it becomes feasible.

Countries and regional blocs that have clear policies to promote the circular economy can develop and/or increase their internal capacity to transform waste into resources. It should be expected that roadmaps and similar instruments currently being developed in LAC act as a stimulus in this direction. Those countries that do not have the scale or capacity to valorize waste find the necessary ally in international trade to move these materials to countries that can. Trade in waste between Mexico and the United States shows that industrial integration within trade blocs also promotes the circular economy. In this case, although the United States does not have a public policy regarding the circular economy, the dynamics of regional value chains increasingly incorporate, at least, recycling activities.

¹⁸ Interview with Nicolas Werba, Commercial Manager, and Marcelo Fosati, Plant Engineer, of Werba S.A. Werba is a Uruguayan company that currently focuses on the recycling of metal, electrical, and electronic products. They condition 95 per cent of the materials that enter the plant for reuse. The remaining 5 per cent is comprised of plastics that cannot be reused and are disposed of.

The circular economy improves the resilience of production chains. The substitution of virgin raw materials with secondary raw materials, and the development of virtuous production and consumption cycles in the territory, will reduce the volumes and shorten the distances of inter- and intraregional trade flows identified under a circular economy logic. The resulting dynamic will depend on the optimization of scales, technological developments and regulatory incentives.

For a more sustainable post-pandemic recovery in LAC, a circular economy strategy would be to foster local value addition in production chains. The region can capitalize on the opportunities provided by international trade by generating circular productive integration mechanisms in partnership with the international private sector to establish regional hubs for material valorization. This would allow the region to leverage its comparative advantages to access European markets and specific niches in Asia and the United States, with circularity requirements. LAC also has favourable conditions to promote services that increase circularity, for example, through the platform economy or specialized services. Moreover, the biological cycle of the circular economy is of special relevance to the region; therefore, it is key to generate synergies with bioeconomy initiatives, where international trade has special features.

Increasing the regional valorization of materials would allow for greater availability of quality secondary raw material in the region, and for developing a complementary industry to the extraction of virgin raw materials. LAC has minimal participation in global trade in waste, focusing primarily on mineral and metal waste exports, specifically of (in decreasing order) steel, aluminium, and copper. Given the right conditions, secondary production of certain metals can be more profitable than primary production. The minimum necessary scale can be achieved by encouraging scrap imports, complemented by the development of urban mining. The circularization of mineral waste would also have a positive social impact by promoting the formalization of the recycling industry in the region, which is currently characterized by its informality and precariousness.

Due to lack of data, the potential contribution of international trade to the circular economy is underestimated. Although multiple links can be established between international trade and the circular economy at a conceptual level, they are difficult to quantify. This is partly because the HS only identifies waste without differentiating between new and used products. New tariff codes and greater specificity are needed in the HS to clearly differentiate in favour of more circular products. Likewise, the logic of international trade is based on products and services, but not on the production process (circular or non-circular). For example, no distinction is made between aluminium products made from virgin raw material and those made from recycled aluminium. Even trade policies that encourage circularity focus on trade flows associated with recycling, which is only one of the many strategies of the circular economy. It is a valuable first step that the HS 2022 Edition will include specific codes for WEEE, facilitating its traceability. Once there

is better traceability of waste, the focus should first be on reducing its generation and not only on identifying its origin and destination, but also its quality.

Global trade in waste represents only a small proportion of the total volume of waste generated. This trade is concentrated in a few profitable secondary raw materials, mainly minerals and metals. Mineral and metal waste trade is strongly dependent on the variation of the unit value of virgin products. Other products, such as plastics (especially single-use plastics), have less commercial potential due to the characteristics of the product itself and the cost associated with converting it for other production processes.

To enhance the contribution of international trade to the circular economy transition in LAC, some policy recommendations are proposed below, taking into account global trends, the instruments being developed in the LAC region and research gaps where further analysis would be relevant

5.2 Recommendations

5.2.1 Research gaps

To scale up the circular economy, national policies (such as circular economy roadmaps) and instruments to be executed by private parties (such as EPR schemes) should seek greater synergies with international trade and incorporate the opportunities and challenges that trade poses for the country and region. It is pertinent to analyse the potential links between national circular economy strategies and each country's foreign trade policy, as well as the specific actions being promoted.

The transition to a circular economy requires improving the available data and its analysis. First, there is a need to better understand the quality and quantity of materials available in the region. Second, to calculate the reduction in demand for LAC's virgin natural resources as a result of a possible substitution with secondary raw materials under the scenario of a circular economy, two trends need to be contrasted. The first refers to lower demand due to greater efficiency in the reuse and recycling of materials. The second refers to increased demand for virgin raw materials due to technological changes. In this context, it is also relevant to analyse the effect on trade of the ban on the import of plastic waste to China and other Asian countries.

Developing definitions for the different types of circular economy goods and their trade classifications can help drive debate and decision making. While efforts to adjust the HS to these challenges continue—which takes time—work could be done to identify the most relevant tariff codes for the region within the framework of schemes that encourage circularity in specific sectors and products.

It is also necessary to analyse the opportunities for circularity of the main LAC export sectors through two mechanisms. First, to produce circular goods and services that access demanding markets. Focusing on the implications of the European Green Deal for LAC's foreign trade may be an initial step. Second, to identify opportunities for importing waste and recycled materials to become secondary producers or to incorporate them into other productive processes. This will allow for the identification of trends that contribute to the incorporation of international trade into national circular economy strategies.

In effect, each subregional bloc (such as the Pacific Alliance, CARICOM, the Andean Community, the Central American Common Market and MERCOSUR) can develop its own commercial circuits for the recovery of raw materials from waste as treatment capacity exists among the different countries. It would be useful to identify which national measures limit the possible development of these flows and how to boost them. Likewise, it is necessary to further study the distribution of plants and the logistics of recovery and recycling in the region, the type of inputs they use, as well as their installed capacities and future projections. This would make it possible to guide future investments at the regional level.

Considering the incentives and disincentives that exist between the circular economy and international trade, the reasons for such low participation of LAC in trade in waste need to be more clearly identified.

Compiling successful experiences of international cooperation and case studies of the incorporation of circular processes and products in international markets could contribute to the search for new business opportunities based on the circular economy.

Finally, it is relevant to analyse how to mainstream the circular economy issue in the agenda of other international law instruments that also promote sustainable trade in natural resources, address the field of biodiversity, regulate the marketing of pesticides and hazardous chemicals or products with persistent organic pollutants or the use of mercury in production. Among them are the Rotterdam Convention, Stockholm Convention, Minamata Convention and the Convention on Biological Diversity.

5.3 Policy recommendations

The opportunities and challenges associated with international trade need to be incorporated into LAC's circular economy public policy agendas, following in the EU's footsteps within the framework of its Green Deal. Circular economy strategies in LAC have only recently been approved or are currently being developed, making it possible to include the link with foreign trade. It would be preferable for the countries of the region to not act independently. LAC should agree on common criteria for developing circular sectors in line with the parameters being established by its trade partners such as China, the United States and the EU. For example, criteria could be established for importing certain materials or promoting companies that export circular goods or services.

The development of standards and certifications can guarantee the circularity of both goods and services and/or production processes. The development of standards has in some cases led to a multiplicity of different regulations. These are not always compatible with each other, and involve significant efforts (financial, among others) that yield few results. Certifications of circularity should be standardized or should at least be based on the same criteria. Regional coordination work on these instruments is necessary. Efforts for environmental or ecological labelling in the region should be coordinated.

Achieving greater economies of scale in LAC requires harmonization of trade criteria, definitions and regulations. The circular economy is much more than trade in waste; it also includes trade in used and second-hand goods, reconditioned and remanufactured goods, secondary raw materials and trade in services (product-as-a-service, advisory services, design, etc.). The fact that there are no agreed definitions and that each country defines its standards is a non-tariff barrier that needs to be lifted.

Optimizing economies of scale in the region also requires consolidating and promoting the formalization of the recycling industry through financial and regulatory incentives and increased compliance monitoring. This will help reduce informal recycling and illegal trade in WEEE and plastics, among others. At the same time, formalization allows for greater traceability of trade flows and reliable information on actual recycling rates.

Deepening the dialogue in multilateral and regional instances regarding the challenges and disincentives of international trade for the circular economy will make it possible to find new solutions. This is just as valid in the WTO as it is between and within subregional integration blocs, in bilateral negotiations and in areas such as within the Basel Convention, since trade with weak or unclear rules is detrimental to all involved. It is important for the region to adopt a joint vision to be able to negotiate at the multilateral level.

Further work is needed to eliminate unnecessary barriers to trade in waste and to generate local management alternatives. It is also necessary to move from only encouraging recycling to promoting other circular economy practices. In those industries where no potential for circularity is detected in the region, reducing consumption as well as using and developing alternative products should be encouraged to minimize waste exports.

International cooperation is key for the transfer and creation of knowledge and best practices and the development of technology. In this regard, LAC has needs but also has knowledge to contribute to the international community. The transition to a circular economy must consider the degree of development of the different trading partners, meaning solutions may vary between countries or subregions within LAC. It is therefore necessary to support R&D to ensure that technology is adapted to the local reality. Although circular trade flows between LAC and the EU are not relevant at present, the space generated by trade agreements could allow for the establishment of cooperation activities to strengthen national circular economy schemes.

The European experience in circular economy promotion policies and programmes has contributed to the development of national roadmaps in LAC and can contribute even more to aspects such as technology R&D.

Cooperation should not only focus on the development of public and trade policies, but also on the productive and entrepreneurial level. The creation of circular GVCs requires joint efforts with other countries to design the circularity of materials. On the other hand, the stringent environmental and circularity requirements of the European market can provide incentives to improve products and processes; however, it can also become an obstacle to trade. The promotion of circular products and sectors, therefore, becomes relevant. For example, developing and/or attracting investments in advanced technologies is crucial for LAC to become a relevant actor in the bioeconomy. Likewise, the promotion of circular business models requires combating illegal trade, which interferes with economies of scale by taking demand away from formally active companies. It is also necessary to demand greater transparency, implement in-depth monitoring and condemn greenwashing. In addition to deceptive labelling practices, some companies which today seem to be complying with global circularity standards, at the same time integrate trade associations and lobby groups that try to weaken and delay the establishment and implementation of policies and incentives towards circularity.

Areas of cooperation with the EU as a key trading partner for LAC are worth exploring, taking advantage of its willingness to improve the coherence of its Circular Economy Action Plan through sustainable development and trade. An interesting recommendation for LAC from the Institute for European Environmental Policy (IEEP) (2019), among others, is to create incentives for circular economy goods through an international agreement to reduce trade barriers to environmental goods. Another is the creation of a knowledge and information exchange platform, both internally for the EU, and externally for the EU and its trading partners.

Bibliography

- Aboal, D., Arias-Ortiz, E., Crespi, G., Garda, P., Rasteletti, A., Rubalcaba, L., Vargas, F. (2015). *La innovación y la nueva economía de servicios en América Latina y el Caribe. Retos e implicaciones de política* [Innovation and the New Service Economy in Latin America and the Caribbean. Challenges and Policy Implications]. Montevideo: IADB.
- ABTN. (18 July 2020). *Rótulo Ecológico* [Ecological Label]. Retrieved from Associação Brasileira de Normas Técnicas (ABNT): <https://www.abntonline.com.br/sustentabilidade/Rotulo/Default>.
- Asociación para el estudio de Residuos Sólidos. (25 October 2019). *Estrategia Nacional de Economía Circular* [National Circular Economy Strategy]. Retrieved from Asociación para el estudio de Residuos Sólidos (ARS): <http://ars.org.ar/destacados/estrategia-ancional-de-economia-circular/>.
- Basel Action Network. (10 May 2019). *Basel Convention Agrees to Control Plastic Waste Trade*. Retrieved from Basel Action Network: <https://www.ban.org/news/2019/5/10/basel-convention-agrees-to-control-plastic-waste-trade>.
- BIR. (2016c). *Global non-ferrous scrap flows 2000-2015 with a focus on aluminum and copper*. Brussels: BIR.
- _____(2019b). *World steel recycling in figures 2014-2018. Steel scrap a raw material for steelmaking*. Brussels: BIR.
- _____(2020a). *Paper and board recycling in 2018. Overview of world statistics*. Brussels: BIR.
- Braungart, M. M., & Bollinger, A. (2007). Cradle-to-cradle design: creating healthy emissions: a strategy for eco-effective product and system design. *Journal of Cleaner Production*, 1337-1348.
- Brazil- Measures Affecting Imports of Retreaded Tyres, DS332 (WTO 25 September 2009).
- Casey, J. (2012). *Patterns in U.S.-China Trade Since China's Accession to the World Trade Organization*. U.S.-China Economic and Security Review Commission.
- Centro Tecnológico del Plástico. (18 July 2020). *+Circular*. Retrieved from Centro Tecnológico del Plástico: <https://ctplas.com.uy/circular/>
- CEPS. (27 July 2016). *Understanding the Circular Economy in Europe, from Resource Efficiency to Sharing Platforms*. Retrieved from CEPS: <https://www.ceps.eu/ceps-publications/understanding-circular-economy-europe-resource-efficiency-sharing-platforms-ceps/>
- Changing Markets Foundation. (2020). *Talking Trash. The corporate playbook of false solutions to the plastic crisis*. Changing Markets Foundation.
- COMTRADE. (n.d.). *United Nations Commodity Trade Statistics Database*. Retrieved from World Bank: <https://wits.worldbank.org/>.

- Copper Alliance. (n.d.). *Recycling: Europe's demand for copper is increasingly met by recycling*. Retrieved from Copper Alliance: <https://copperalliance.eu/benefits-of-copper/recycling/>.
- CORFO. (18 July 2020). *Instituto de Tecnologías Limpias* [Chilean Clean Technologies Institute]. Retrieved from CORFO: https://www.corfo.cl/sites/cpp/convocatorias/instituto_de_tecnologias_limpias_fase_rfp.
- CTCN. (n.d.). *Technical Assistance*. Retrieved from CTCN: <https://www.ctc-n.org/technical-assistance/data>.
- Dellink, R. (2020). *The Consequences of a more resource efficient and circular economy for international trade patterns*. Paris: OECD.
- ECLAC. (2020a). *Special Report COVID-19 No.4. Sectors and businesses facing COVID-19: emergency and reactivation*. Santiago de Chile: ECLAC.
- _____. (2020b). *Special Report COVID-19 No. 5. Addressing the growing impact of COVID-19 with a view to reactivation with equality: new projections*. Santiago de Chile: ECLAC.
- _____. (13 March 2020c). *Noticias: Alicia Bárcena reafirma urgencia de transitar hacia un modelo de desarrollo más sostenible que permita aumentar la productividad y alcanzar la igualdad en la región* [News: Alicia Bárcena reaffirms the urgency of moving towards a more sustainable development model that will increase productivity and achieve equality in the region. Retrieved from ECLAC: <https://www.cepal.org/es/noticias/alicia-barcena-reafirma-urgencia-transitar-un-modelo-desarrollo-mas-sostenible-que-permita>.
- _____. (29 June 2020d). *Press report: ECLAC calls for Moving Towards a Big Push for Sustainability as a Strategy for Emerging from the Current Crisis*. Retrieved from ECLAC: <https://www.cepal.org/es/comunicados/cepal-llama-avanzar-un-gran-impulso-la-sostenibilidad-como-estrategia-salida-la-actual>.
- European Commission. (2018). *Modernisation of the Trade Pillar of the EU-Mexico Global Agreement. Trade and Sustainable Development chapter*. Retrieved from: https://trade.ec.europa.eu/doclib/docs/2018/april/tradoc_156822.pdf.
- _____. (2020). *Leading the way for global circular economy: state of play and outlook*. Brussels: European Commission.
- _____. (2020). *New Circular Economy Action Plan*. Brussels: European Commission.
- _____. (14 April 2020). *Strategy-Shaping Europe's digital future-Reports and studies: Innovative services and products for the circular economy – insights from Horizon 2020 projects*. Retrieved from: European Commission: <https://ec.europa.eu/digital-single-market/en/news/innovative-services-and-productscircular-economy-insights-horizon-2020-projects>.
- _____. (n.d). *Environment: International Issues: Circular Economy Missions*. Brussels: European Commission.
- Ellen MacArthur Foundation. (2015). *Towards a Circular Economy: Business Rationale for an Accelerated Transition*. Cowes: Ellen MacArthur Foundation.

- ____ (2017). *A new textiles economy: redesigning fashion's future*. Cowes: Ellen MacArthur Foundation.
- ____ (2019a). *Completing the Picture: How the Circular Economy Tackles Climate Change*. Cowes: Ellen MacArthur Foundation.
- ____ (2019b). *Resources: Apply: Circulytics-measuring circularity: Resources*. Cowes: Ellen MacArthur Foundation. Retrieved from Ellen MacArthur Foundation: <https://www.ellenmacarthurfoundation.org/assets/downloads/Circulytics-definitions-list.pdf>.
- ____ (7 July 2020). *Episode 8: Circular economy opportunities in China*. Retrieved from Ellen MacArthur Foundation: <https://youtu.be/orxlvZOB3YI>.
- EuRIC AISBL. (2020). *Metal Recycling Factsheet*. Belgium: EuRIC AISBL. Retrieved from <https://circulareconomy.europa.eu/platform/en/knowledge/metal-recycling-factsheet-euric>.
- European Aluminium. (2020). *Circular Aluminium Action Plan. A strategy for achieving aluminium's full potential for circular economy by 2030*. Brussels: European Aluminium.
- European Topic Centre on Waste and Materials in a Green Economy. (2019). *Textiles and the environment in a circular economy*. Mol: European Topic Centre on Waste and Materials in a Green Economy.
- EU-Chile. (2018). *EU proposal chapter trade and sustainable development*. Brussels: EU.
- EU-MERCOSUR. (2019). *New EU-Mercosur trade agreement. Chapter: Trade and Sustainable Development*. Brussels: EU.
- European Union. (19 de 11 de 2008). *Directive 2008/98/EC*. Retrieved from European Union: <https://eur-lex.europa.eu/eli/dir/2008/98/oj/spa..>
- Forti, V., Baldé, C., Kuehr, R., & Bel, G. (2020). *The Global E-waste Monitor 2020. Quantities, flows, and the circular economy potential*. Bonn/Geneva/Rotterdam: UNU-UNITAR-ITU-ISWA.
- Gálvez-Martos, J., Istrate, I., & García, D. (2018). *Estudio de perspectiva de economía circular en la gestión de baterías de coche eléctrico en su fin de vida [Prospective Study on the Circular Economy in the Management of Electric Car Batteries at the End-of-Life]*. Madrid: Unidad de Análisis de Sistemas, IMDEA Energía.
- Government of Costa Rica. (2018). *Plan de Descarbonización [National Decarbonization Plan]*. San José: Government of Costa Rica
- Government of the Republic of Colombia. (2019). *Estrategia nacional de economía circular. Cierre de ciclos de materiales innovación tecnológica, colaboración y nuevos modelos de negocio [National Strategy for a Circular Economy: closing of material cycles, technological innovation, collaboration and new business models]*. Bogotá: Presidencia de la República; Ministerio de Ambiente y Desarrollo Sostenible; Ministerio de Comercio, Industria y Turismo.

- Government of the Republic of Costa Rica. (2018). *Política Nacional de Producción y Consumo Sostenibles 2018 – 2030* [National Policy on Sustainable Production and Consumption 2018-2030]. San José: Government of the Republic of Costa Rica
- Government of Peru. (February 2019). *Decreto Supremo N° 003-2020-Produce* [Supreme Decree N° 003-2020-Produce]. Retrieved from Diario Oficial El Peruano: <https://busquedas.elperuano.pe/normaslegales/decreto-supremo-que-aprueba-la-hoja-de-ruta-hacia-una-econom-decreto-supremo-n-003-2020-produce-1856966-1/>.
- Greenpeace. (2019). *Data from the global plastics waste trade 2016-2018 and the offshore impact of China's foreign waste import ban. An analysis of import-export data from the top 21 exporters and 21 importers*. Greenpeace East Asia.
- Hanni, M., & Podestá, A. (2019). *Trade misinvoicing in copper products: a case study of Chile and Peru*. Santiago de Chile: CEPAL Review No.127, p. 91-108
- IADB. (2016). *Analysis of the Challenges in the Development of the Recycling Value Chain in Central America*. Inter-American Development Bank
- ICSG. (2019). *The World Copper Factbook*. Lisboa: International Copper Study Group.
- Ilankoon, I., Ghorbani, Y., Chong, M., Herath, G., Moyo, T., & Peterson, J. (2018). E-waste in the international context- A review of trade flows, regulations, hazards, waste management strategies and technologies for value recovery. *Waste Management. Volume 82*, 258-275.
- International Copper Association. (2017). *Copper Recycling*. New York: International Copper Association.
- International Resource Panel. (2020). *Resource Efficiency and Climate Change: Material Efficiency Strategies for a Low-Carbon Future*. Nairobi: UN Environment Programme.
- Interpol. (2020). *Strategic analysis report. Emerging criminal trends in the global plastic waste market since January 2018*. Lyon: Interpol.
- ISO. (2019). *ISO TC 323: Strategic Business Plan: Circular Economy*. Retrieved from ISO: https://isotc.iso.org/livelink/livelink/fetch/2000/2122/687806/ISO_TC_323__Circular_Economy_.pdf?nodeid=21218393&vernum=-2.
- ISRI. (2020). *2019 Recycling Industry Yearbook*. Washington: Institute of Scrap Recycling Industries.
- Joltreau, E. (2019). *(De)Globalization of international plastic waste trade. Stakes at play and perspectives*. Paris: Éditoriaux de l'Ifri.
- Kaza, S., Yao, L., Bhada-Tata, P., & Van Woerden, F. (2018). *What a Waste 2.0: A Global Snapshot of Solid Waste Management to 2050. Urban Development Series*. Washington: World Bank.
- Kettunen, M., Gionfra, S., & Monteville, M. (2019). *EU circular economy and trade: Improving policy coherence for sustainable development*. Brussels/London: IEEP.
- Kojima, M. (2017). *Remanufacturing and trade regulation*. Chiba: Elsevier B.V.

- McCarthy, A., & Börkey, P. (2018). *Mapping support for primary and secondary metal production*. Paris: OECD Environment Working Papers, No. 135.
- McCarthy, A., Dellink, R., & Bibas, R. (2018). *The Macroeconomics of the Circular Economy Transition: A Critical Review of Modelling Approaches*. Paris: OECD.
- Ministry of Environment. (4 October 2019). *Prensa: MiAmbiente firma acuerdo para la creación del Centro de Economía Circular* [Press: MiAmbiente signs agreement for the creation of a circular economy center]. Retrieved from Ministry of Environment: <https://www.miambiente.gob.pa/miambiente-firma-acuerdo-para-la-creacion-del-centro-de-economia-circular/>.
- Ministry of Environment and Sustainable Development. (5 August 2018). *Minambiente reglamenta la gestión de residuos de envases y empaques en Colombia* [Minambiente regulates the management of packaging waste in Colombia]. Retrieved from Ministry of Environment and Sustainable Development: <https://www.minambiente.gov.co/index.php/noticias-minambiente/4085-min-ambiente-reglamenta-la-gestion-de-residuos-de-envases-y-empaques-en-colombia>.
- Ministry of Environment and Sustainable Development. (18 July 2020). *Sello Ambiental Colombiano* [Colombian Environmental Seal]. Retrieved from Ministry of Environment and Sustainable Development: <https://www.minambiente.gov.co/index.php/component/content/article?id=366:plantilla-asuntos-ambientales-y-sectorial-y-urbana-19>.
- Ministry of Development Planning. (21 December 2010). *Ley de Derechos de la Madre Tierra* [Law of the Rights of Mother Earth]. Retrieved from Ministry of Development Planning: <http://www.planificacion.gob.bo/uploads/marcolegal/Ley%20N%C2%B0%20071%20DE RECHOS%20DE%20LA%20MADRE%20TIERRA.pdf>.
- Molina Alomar, J. (16 March 2020). *Medio Ambiente convoca a 25 actores clave para desarrollar la hoja de ruta que impulsará la adopción de la economía circular en Chile* [Ministry of Environment convenes 25 key actors to develop the roadmap that will drive the adoption of the circular economy in Chile]. Retrieved from País Circular: <https://www.paiscircular.cl/consumo-y-produccion/medio-ambiente-convoca-a-25-actores-clave-para-desarrollar-la-hoja-de-ruta-que-impulsara-la-adopcion-de-la-economia-circular-en-chile/>.
- Nechifor, V., Calzadilla, A., Bleischwitz, R., Winning, M., Tian, X., & Usubiaga, A. (2020). *Steel in a circular economy: Global implications of a green shift in China*. World Development, Volume 127.
- Ocampo, J. (2017). Commodity-Led Development in Latin America. *Alternative Pathways to Sustainable Development: Lessons from Latin America. International Development Policy Series No. 9*, 51-76.
- OECD. (18 November 2008). *OECD/LEGAL/0266*. Retrieved from: <https://legalinstruments.oecd.org/en/instruments/OECD-LEGAL-0266>.
- _____. (2015). *Addressing information gaps on prices of mineral products: mineral product pricing practices case studies: copper, gold and iron ore*. Paris: OECD.

- _____ (2016). *Policy Guidance on Resource Efficiency*. Paris: OECD.
- _____ (2018a). *Business Models for the Circular Economy: Opportunities and Challenges from a Policy Perspective*. Paris: OECD.
- _____ (2018b). *Improving plastics management: trends, policy responses, and the role of international co-operation and trade*. OECD.
- _____ (2019). *Global Material Resources Outlook to 2060: Economic Drivers and Environmental consequences*. Paris: OECD. Retrieved from <https://doi.org/10.1787/9789264307452-en>.
- _____ (2020). *Improving resource efficiency and the circularity of economies for a greener world. Policy perspectives*. OECD Environment Directorate.
- Olmos, X. (2019). *El comercio internacional como incentivo a la sostenibilidad. La experiencia de la Red Latinoamericana y del Caribe de la huella ambiental del café* [International Trade as an Incentive for Sustainability. The Experience of the Latin American and Caribbean Network for the Environmental Footprint of Coffee]. Santiago de Chile: ECLAC.
- Pan American Standards Commission (COPANT). (n.d). *Pan American Standards Commission*. Retrieved from COPANT: <https://copant.org/index.php/es/>.
- Parliament of El Salvador. (2 February 2020). *Ley de Gestión Integral de Residuos y Fomento al Reciclaje* [Law on Integral Waste Management and Promotion of Recycling]. Retrieved from Diario Oficial: <https://www.diariooficial.gob.sv/diarios/do-2020/02-febrero/27-02-2020.pdf>.
- Parliament of Uruguay. (18 September 2019). *Ley General de Gestión Integral de Residuos* [Integral Waste Management Law]. Retrieved from IMPO: <https://www.impo.com.uy/bases/leyes/19829-2019>.
- RECYT. (2019). *LX Reunión Especializada de Ciencia y Tecnología. Acta Nro2* [60th Specialized Meeting on Science and Technology, Act No.2]. Brasilia: MERCOSUR.
- Rodriguez, A., Mondaini, A. & Hitschfeld, M. (2017). *Bioeconomía en América Latina: contexto global y regional y perspectivas* [Bioeconomy in Latin America and the Caribbean: global and regional context and perspectives]. Santiago: ECLAC.
- Sauvage, J. (2019). *Measuring Distortions in International Markets. The Aluminium Value Chain*. Paris: OECD.
- Schröder, P., Anggraeni, K., & Weber, U. (2018). *The Relevance of Circular Economy Practices to the Sustainable Development Goals*. Yale University.
- Schröder, P., MacEwen, M., Albaladejo, M., Alonso Ribas, P., & Tilkanen, J. (2020). *The Circular Economy in Latin America and the Caribbean. Opportunities for building resilience*. London: Chatham House.
- Senate of Mexico. (12 November 2019). *Gaceta: LXIV/2PPO-51/101326*. Retrieved from Senate of Mexico: https://www.senado.gob.mx/64/gaceta_del_senado/documento/101326.

- Sindicato de Industriales de Panamá. (19 de julio de 2020). *Sello Panamá Verde*. Retrieved from Sindicato de Industriales de Panamá: <https://industriales.org/proyectos/sello-panama-verde/>.
- Steinfatt, K. (June 2020). *Working Papers: Trade policies for a circular economy: What can we learn from WTO experience?* Retrieved from WTO: https://www.wto.org/english/res_e/reser_e/ersd202010_e.htm.
- The Aluminium Association. (n.d.). *Industries: Production: Primary Production*. Retrieved from The Aluminium Association: <https://www.aluminum.org/industries/production/primary-production>.
- The Cradle to Cradle Products Innovation Institute. (18 July 2020). *What is Cradle to Cradle Certified™?* Retrieved from The Cradle to Cradle Products Innovation Institute: <https://www.c2ccertified.org/get-certified/product-certification>.
- The Fletcher School. (10 February 2020). *Digital Evolution Index*. Retrieved from The Fletcher School: <https://sites.tufts.edu/digitalplanet/tag/digital-evolution-index/>.
- Thimmiah, S. (20 February 2014). Where are miners and metals companies in the circular economy? *The Guardian*, <https://www.theguardian.com/sustainable-business/mining-metals-circular-economy>.
- Transforma Uruguay. (2019). *Plan de Acción en Economía Circular* [Circular Economy Action Plan]. Montevideo: Transforma Uruguay.
- UN. (7 April 2020). *Noticias: La pandemia de coronavirus es una oportunidad para construir una economía que preserve la salud del planeta* [News: The coronavirus pandemic is an opportunity to build an economy that preserves the health of the planet]. Retrieved from UN News: <https://news.un.org/es/story/2020/04/1472482>.
- UNACEM. (2020). *Resumen del informe final de la consultoría para la fase I del libro blanco de economía circular* [Summary of the Final Report of the Consultancy for Phase I of the White Paper on Circular Economy]. Quito: UNACEM.
- UNEP. (2011). *Recycling Rates of Metals, A Status Report*. UNEP.
- _____. (2018). *Waste Management Outlook for Latin America and the Caribbean*. Panama: United Nations Environment Programme Latin America and the Caribbean Office.
- _____. (6 November 2019). *Conclusions and recommendations of the Intersessional Meeting of the Forum of Ministers of Environment of Latin America and the Caribbean*. Retrieved from UNEP: <https://www.unenvironment.org/events/un-environment-event/intersessional-meeting-forum-ministers-environment-latin-america-and>.
- _____. (2020). *“Can I Recycle This?” A Global Mapping and Assessment of Standards, Labels and Claims on Plastic*. UNEP.
- UNIDO. (2017). *Circular Economy*. Vienna: UNIDO.
- United States Environmental Protection Agency. (n.d). *Secondary Copper Smelting*. Washington: Environmental Protection Agency.

- UNU. (2015). *eWaste in Latin America. Statistical Analysis and Policy Recommendations*. United Nations University.
- Valles, G. (2016), "The Circular Economy in International Trade", United Nations Conference on Trade and Development (UNCTAD), Geneva. <http://unctad.org/en/pages/newsdetails.aspx?OriginalVersionID=1400>.
- Wellesley, L., Lehne, J., & Preston, F. (2019). *An Inclusive Circular Economy: Priorities for Developing Countries*. London: Chatham House.
- Wiedmann, T., Schandl, H., Lenzen, M., Moran, D., Suh, S., West, J., & K, K. (2015). *The material footprint of nations*. Barcelona: Autonomous University of Barcelona.
- World Economic Forum. (2020). *Plastics, the Circular Economy and Global Trade*. Geneva: World Economic Forum.
- WTO. (27 November 2019). *Noticias: El papel del comercio en la promoción de la economía circular se puso de relieve en la Semana del Medio Ambiente organizada por la OMC* [News: The role of trade in promoting the circular economy was highlighted at the WTO Trade and Environment Week]. Retrieved from WTO: https://www.wto.org/spanish/news_s/news19_s/envir_03dec19_s.htm.
- _____ (31 July 2020). *WTO's Environmental Database (EDB)*. Retrieved from WTO: <https://edb.wto.org/>
- _____ (2020). *Communication on trade in plastics, sustainability and development by the United Nations Conference on Trade and Development (UNCTAD). JOB/TE/63*. Geneva: WTO Committee on Trade and Environment.
- Yamaguchi, S. (2018). *International Trade and the Transition to a more resource efficient and circular economy: A Concept paper*. Paris: OECD.

Annexes

Annex 1

Table A1 Tariff codes considered in each mega-industry

Harmonized System 2002	Mega-industry
090190	Agriculture, food and beverages
152200	Agriculture, food and beverages
180200	Agriculture, food and beverages
230310	Agriculture, food and beverages
230320	Agriculture, food and beverages
230330	Agriculture, food and beverages
230500	Agriculture, food and beverages
230610	Agriculture, food and beverages
230620	Agriculture, food and beverages
230630	Agriculture, food and beverages
230641	Agriculture, food and beverages
230649	Agriculture, food and beverages
230650	Agriculture, food and beverages
230660	Agriculture, food and beverages
230690	Agriculture, food and beverages
230700	Agriculture, food and beverages
240130	Agriculture, food and beverages
440130	Wood, cellulose, paper and cardboard
440130	Wood, cellulose, paper and cardboard
450190	Wood, cellulose, paper and cardboard
470710	Wood, cellulose, paper and cardboard
470720	Wood, cellulose, paper and cardboard
470730	Wood, cellulose, paper and cardboard

Harmonized System 2002	Mega-industry
470790	Wood, cellulose, paper and cardboard
252530	Minerals and metals (including manufactures)
261800	Minerals and metals (including manufactures)
261900	Minerals and metals (including manufactures)
262011	Minerals and metals (including manufactures)
262019	Minerals and metals (including manufactures)
262021	Minerals and metals (including manufactures)
262029	Minerals and metals (including manufactures)
262030	Minerals and metals (including manufactures)
262040	Minerals and metals (including manufactures)
262060	Minerals and metals (including manufactures)
262091	Minerals and metals (including manufactures)
262099	Minerals and metals (including manufactures)
262110	Minerals and metals (including manufactures)
271091	Minerals and metals (including manufactures)
271099	Minerals and metals (including manufactures)
700100	Minerals and metals (including manufactures)
711230	Minerals and metals (including manufactures)
711291	Minerals and metals (including manufactures)
711292	Minerals and metals (including manufactures)
711299	Minerals and metals (including manufactures)
720410	Minerals and metals (including manufactures)
720421	Minerals and metals (including manufactures)
720429	Minerals and metals (including manufactures)
720430	Minerals and metals (including manufactures)
720441	Minerals and metals (including manufactures)

Harmonized System 2002	Mega-industry
720449	Minerals and metals (including manufactures)
720450	Minerals and metals (including manufactures)
740400	Minerals and metals (including manufactures)
750300	Minerals and metals (including manufactures)
760200	Minerals and metals (including manufactures)
780200	Minerals and metals (including manufactures)
790200	Minerals and metals (including manufactures)
800200	Minerals and metals (including manufactures)
810197	Minerals and metals (including manufactures)
810297	Minerals and metals (including manufactures)
810330	Minerals and metals (including manufactures)
810420	Minerals and metals (including manufactures)
810530	Minerals and metals (including manufactures)
810730	Minerals and metals (including manufactures)
810830	Minerals and metals (including manufactures)
810930	Minerals and metals (including manufactures)
811020	Minerals and metals (including manufactures)
811213	Minerals and metals (including manufactures)
811222	Minerals and metals (including manufactures)
811252	Minerals and metals (including manufactures)
852810	Minerals and metals (including manufactures)
854890	Minerals and metals (including manufactures)
300680	Chemicals, plastics and rubber
382510	Chemicals, plastics and rubber
382520	Chemicals, plastics and rubber
382541	Chemicals, plastics and rubber

Harmonized System 2002	Mega-industryr
382549	Chemicals, plastics and rubber
382550	Chemicals, plastics and rubber
382561	Chemicals, plastics and rubber
382569	Chemicals, plastics and rubber
382590	Chemicals, plastics and rubber
391510	Chemicals, plastics and rubber
391520	Chemicals, plastics and rubber
391530	Chemicals, plastics and rubber
391590	Chemicals, plastics and rubber
400400	Chemicals, plastics and rubber
411520	Textile and leather
430220	Textile and leather
500390	Textile and leather
510320	Textile and leather
510330	Textile and leather
520210	Textile and leather
520291	Textile and leather
520299	Textile and leather
530130	Textile and leather
530290	Textile and leather
530390	Textile and leather
550510	Textile and leather
550520	Textile and leather
631010	Textile and leather
631090	Textile and leather

Source: Prepared by the authors.

Annex 2

Table A2 Countries of Latin America: Waste exports by mega-industry, 2018

(in thousands of tonnes)

Country/Mega-industries	Agriculture and food	Wood, paper and cardboard	Mineral and metal	Chemical and plastic	Textile and leather	Total
Argentina	221 676	11 499	13 121	912	867	248 074
Bahamas	-	136	3 835	-	-	3 971
Barbados	0	513	411	-	-	924
Belize	-	845	22 103	73	-	23 021
Bolivia (Plurinational State of)	52 353	2 705	50 546	787	275	106 666
Brazil	17 962	24 536	241 744	4 741	652	289 635
Chile	23 358	28 497	103 311	5 111	243	160 519
Colombia	1 571	217	13 098	1 184	300	16 370
Costa Rica	12 297	42 182	42 088	4 363	454	101 384
Cuba	-	89	-	-	-	89
Dominican Republic	6	22 715	11 909	3 564	870	39 064
Ecuador	447	6 546	2 305	3 798	454	13 550
El Salvador	969	22 460	14 342	8 387	5 926	52 084
Guatemala	12 924	50 086	20 545	1 730	1 244	86 529
Guyana	217	153	366	52	-	789
Haiti	-	-	2 512	-	-	2 512
Honduras	8 818	21 816	20 268	532	7 637	59 071
Jamaica	-	2 472	3 657	-	0	6 129
Mexico	100	3 692	170 220	6 817	1 560	182 388
Nicaragua	16 123	29 950	38 560	5 270	1 718	91 621
Panama	638	11 120	11 884	2 915	2	26 558
Paraguay	-	5 674	35 858	1 933	56	43 521
Peru	61	13 176	4 460	646	1 701	20 044

Suriname	-	-	121	-	-	121
Trinidad y Tobago	-	136	77	120	60	393
Uruguay	688	21 004	6 930	541	86	29 249
Venezuela	-	209	12 549	6 497	7	19 261

Source: Prepared by the authors.

Table A3 Countries of Latin America: Waste imports by mega-industry, 2018

(in thousands of tonnes)

Country/Mega-industries	Agriculture and food	Wood, paper and cardboard	Mineral and metal	Chemical and plastic	Textile and leather	Total
Argentina	7 666	31 353	96 125	1 653	416	137 213
Barbados	-	136	-	-	40	176
Belize	-	123	3	-	-	126
Bolivia (Plurinational State of)	126	5 323	105	1 742	275	7 571
Brazil	15 710	22 052	107 144	4 027	4 992	153 925
Chile	83 014	5 336	4 027	4 860	633	97 870
Colombia	9 404	48 571	155 078	6 662	165	219 881
Costa Rica	1 369	6 376	34 875	4 295	336	47 250
Cuba	85	6	21	-	3	115
Dominican Republic	55	2 217	0	21	25	2 317
Ecuador	1 086	51 192	102 830	5 192	1 594	161 894
El Salvador	14 703	31 783	430	2 868	2 024	51 809
Guatemala	6 807	13 266	117 935	724	1 526	140 259
Guyana	-	-	68	-	20	87
Honduras	8 720	138	2 275	13 949	3 699	28 781

Jamaica	-	-	0	78	-	78
Mexico	803	33 112	20 797	911	6 962	62 585
Nicaragua	14 918	304	84 631	382	361	100 596
Panama	1 728	154	3 320	-	18	5 220
Paraguay	28 333	16 757	25 600	2 040	240	72 969
Peru	27 849	38 065	88 345	9 657	201	164 117
Suriname	-	-	342	-	-	342
Trinidad y Tobago	623	585	483	-	22	1 713
Uruguay	143 350	5 419	2 387	732	439	152 328
Venezuela	3 860	10 159	-	177	119	14 316

Source: Prepared by the authors.



CEPAL

International Trade

Issues published

A complete list as well as pdf files are available at

www.cepal.org/publicaciones

- xxx. El comercio internacional y la economía circular en América Latina y el Caribe, Nanno Mulder, coordinador, (LC/TS.2020/XXX), 2020.
- xxx. Infraestructura Resiliente: un imperativo para el desarrollo sostenible en América Latina y el Caribe, Fabio Weikert, (LC/TS.2020/XXX), 2020.
- 155. Bilateral effects on non-tariff measures on international trade: volume-based panel estimates, Marcelo Dolabella, (LC/TS.2020/107), 2020.
- 154. Estado de la implementación del Programa de Acción de Viena en favor de los Países en Desarrollo Sin Litoral para el Decenio 2014-2024, Gabriel Pérez y Ricardo J. Sánchez, (LC/TS.2020/3), 2020.
- 153. Herramientas de política comercial para contribuir a la igualdad de género, Alicia Frohmann, (LC/TS.2019/111), 2019.
- 152. Políticas de movilidad y consideraciones de género en América Latina, Gabriel Pérez, (LC/TS.2019/108), 2019.
- 151. Integración regional y facilitación de la logística en América del Sur, Héctor Maldonado y Gabriel Pérez, (LC/TS.2019/107), 2019.
- 150. Contratos de concesión de infraestructura incompletitud, obstáculos y efectos sobre la competencia, Ricardo J. Sánchez y Pablo Chauvet (LC/TS.2019/104), 2019.
- 149. Imported inputs and export performance: evidence from Chilean manufacturing industries, Dayna Zaalicever, (LC/TS.2019/90), 2019.

148. Latin America's faltering manufacturing competitiveness: what role for intermediate services?, Rolando Avendano, Filippo Bontadini, Nanno Mulder, Dayna Zaclicever, (LC/TS.2019/88), 2019.
147. A network analysis approach to vertical trade linkages: the case of Latin America and Asia, Dayna Zaclicever, (LC/TS.2019/86), 2019.
146. Status of implementation in South America of the Vienna Programme of Action for Landlocked Countries for the Decade 2014-2024 (LC/TS.2019/85), 2019.



UNITED NATIONS
INDUSTRIAL DEVELOPMENT ORGANIZATION

Vienna International Centre · P.O. Box 300 9 · 1400 Vienna · Austria
Tel.: (+43-1) 26026-0 · E-mail: info@unido.org
www.unido.org